

FT10 Heavy Duty FloorTrak®



FT10 Heavy Duty FloorTrak -
Safeguards hoses, electrical cables and cords
for people and light vehicle traffic in public,
institutional and commercial applications.



| Catalog Numbers | Color | Length in Feet (Meters) |
|-----------------|--------|-------------------------|
| FT10BK3 | Black | 3' (.914) |
| FT10Y3 | Yellow | 3' (.914) |
| FT10BK5 | Black | 5' (1.52) |
| FT10Y5 | Yellow | 5' (1.52) |

| Catalog Numbers | Description |
|-----------------|---|
| FTT1 | Double Sided Tape - 1" Wide, 75' Roll Double Sided Adhesive Tape |
| FTT2 | Double Sided Tape - 2" Wide, 75' Roll Double Sided Adhesive Tape |

| Technical Specifications | |
|--------------------------|---|
| FloorTrak | FT10 |
| Weight Capacity | Deflection of ½" with 300 lbs. Distributed Over 1 Square Foot Area |
| Operating Temperature | (0 Degrees F to 120 Degrees F) |
| Material | Rigid PVC |

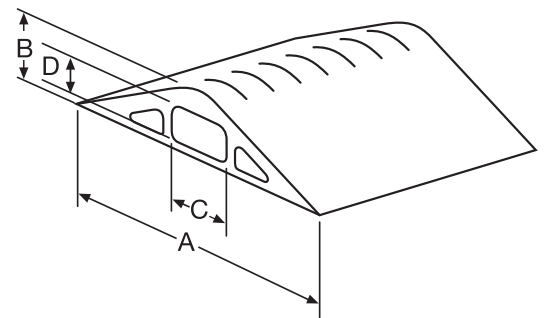

| Dimensions in Inches (mm) | |
|---------------------------|----------------------------------|
| Width (A) | 5.6" (142.24) |
| Height (B) | 1.7" (43.18) |
| Ctr Hole (C X D) | 1.81" X 1.25" (45.98 X 31.75) |

Printed In U.S.A. Specifications subject to change without notice. © Registered trademark of Hubbell Incorporated.

Hubbell Incorporated (Delaware) • 185 Plains Road • Milford, CT 06461-2420 • (203) 882-4800 • FAX (800) 255-1031 H5243-PDF only

www.hubbell-wiring.com

