

ATV340D15N4E

variable speed drive - 15kW- 400V - 3 phases -
ATV340 Ethernet



Product availability: Stock - Normally stocked in distribution facility



Main

Range of product	Altivar Machine ATV340
Product or component type	Variable speed drive
Device application	Machine
Device short name	ATV340
Variant	Standard version
Product destination	Asynchronous motors Synchronous motors
Mounting mode	Cabinet mount
EMC filter	Integrated 65.62 ft (20 m) EN/IEC 61800-3 category C3
IP degree of protection	IP20IEC 61800-5-1 IP20IEC 60529
Type of cooling	Forced convection
Supply frequency	50...60 Hz +/- 5 %
Phase	3 phase
[Us] rated supply voltage	380...480 V - 15...10 %
Motor power kW	18.5 KW normal duty 15 kW heavy duty
Maximum Horse Power Rating	25 Hp normal duty 20 hp heavy duty
Line current	44.9 A 380 V without line choke heavy duty) 35.7 A 480 V without line choke heavy duty) 42.4 A 380 V with external line choke normal duty) 34.1 A 480 V with external line choke normal duty) 45.5 A 380 V with external line choke heavy duty) 36.0 A 480 V with external line choke heavy duty)
Prospective line I _{sc}	22 kA
Apparent power	28.3 KVA 480 V normal duty) 29.7 kVA 480 V heavy duty)
Continuous output current	39 A 4 kHz normal duty 32 A 4 kHz heavy duty
Maximum transient current	42.9 A 60 s normal duty) 48 A 60 s heavy duty) 52.7 A 2 s normal duty) 58 A 2 s heavy duty)
Asynchronous motor control profile	Optimized torque mode Variable torque standard Constant torque standard
Synchronous motor control profile	Reluctance motor Permanent magnet motor
Speed drive output frequency	0.1...599 Hz
Nominal switching frequency	4 kHz
Switching frequency	2...16 kHz adjustable 7...16 kHz with derating factor
Safety function	STO (safe torque off) SIL 3

The information provided in this documentation contains general descriptions and/or technical characteristics of the performance of the products contained herein. This documentation is not intended as a substitute for and is not to be used for determining suitability or reliability of these products for specific user applications. It is the duty of any such user or integrator to perform the appropriate and complete risk analysis, evaluation and testing of the products with respect to the relevant specific application or use thereof. Neither Schneider Electric Industries SAS nor any of its affiliates or subsidiaries shall be responsible or liable for misuse of the information contained herein.

Complementary

Number of preset speeds	16 preset speeds
Communication port protocol	Modbus serial Modbus TCP Ethernet/IP
Option card	Slot GP-X digital and analog I/O extension module Slot GP-X output relay extension module Slot GP-ENC 5/12 V digital encoder interface module Slot GP-ENC analog encoder interface module Slot GP-ENC resolver encoder interface module
Output voltage	<= power supply voltage
Permissible temporary current boost	1.1 x In 60 s normal duty) 1.35 x In 2 s normal duty) 1.5 x In 60 s heavy duty) 1.8 x In 2 s heavy duty)
Motor slip compensation	Automatic whatever the load Not available in permanent magnet motor law Can be suppressed Adjustable
Acceleration and deceleration ramps	Linear adjustable separately from 0.01...9999 s S, U or customized
Braking to standstill	By DC injection
Protection type	Thermal protection motor Safe torque off motor Motor phase loss motor Thermal protection drive Safe torque off drive Overheating drive Overcurrent drive Output overcurrent between motor phase and earth drive Output overcurrent between motor phases drive Short-circuit between motor phase and earth drive Short-circuit between motor phases drive Motor phase loss drive DC Bus overvoltage drive Line supply overvoltage drive Line supply undervoltage drive Input supply loss drive Exceeding limit speed drive Break on the control circuit drive
Frequency resolution	Display unit 0.1 Hz Analog input 0.012/50 Hz
Electrical connection	Control screw terminal 0.2...2.5 mm ² AWG 24...AWG 12 Line side screw terminal 6...25 mm ² AWG 8...AWG 3 DC bus screw terminal 6...25 mm ² AWG 8...AWG 3 Motor screw terminal 4...25 mm ² AWG 10...AWG 3
Connector type	1 x RJ45, Modbus serial on front face 1 x RJ45, Modbus serial HMI on front face 2 x RJ45, Ethernet IP/Modbus TCP on front face
Physical interface	2-wire RS 485 Modbus serial
Transmission frame	RTU Modbus serial
Transmission rate	4800 bps, 9600 bps, 19200 bps, 38.4 Kbps Modbus serial 10/100 Mbit/s Ethernet IP/Modbus TCP
Exchange mode	Half duplex, full duplex, autonegotiation Ethernet IP/Modbus TCP
Data format	8 bits, configurable odd, even or no parity Modbus serial
Type of polarization	No impedance Modbus serial
Number of addresses	1...247 Modbus serial
Method of access	Slave Modbus RTU Slave Modbus TCP
Supply	External supply for digital inputs 24 V DC 19...30 V), <1.25 mA overload and short-circuit protection Internal supply for reference potentiometer (1 to 10 kOhm) 10.5 V DC +/- 5 %, <10 mA overload and short-circuit protection Internal supply for digital inputs and STO 24 V DC 21...27 V), <200 mA overload and short-circuit protection
Local signalling	Local diagnostic 4 LED mono/dual colour) Communication module status 4 LED dual colour)
Width	7.09 in (180 mm)

Height	15.16 in (385 mm)
Depth	9.80 in (249 mm)
Net weight	20.94 lb(US) (9.5 kg)
Analogue input number	2
Analogue input type	AI1 software-configurable current 0...20 mA 250 Ohm 12 bits AI1 software-configurable temperature probe or water level sensor AI1 software-configurable voltage 0...10 V DC 31.5 kOhm 12 bits AI2 software-configurable voltage - 10...10 V DC 20 kOhm 12 bits
Discrete input number	8
Discrete input type	PTI programmable as pulse input 0...30 kHz, 24 V DC <= 30 V) STOA, STOB safe torque off, 24 V DC <= 30 V)> 2.2 kOhm DI1...DI5 programmable, 24 V DC <= 30 V)4.4 kOhm
Input compatibility	DI1...DI5 discrete input level 1 PLC EN/IEC 61131-2 PTI pulse input level 1 PLC IEC 65A-68 STOA, STOB discrete input level 1 PLC EN/IEC 61131-2
Discrete input logic	Positive logic (source) DI1...DI5), < 5 V, > 11 V Negative logic (sink) DI1...DI5), > 16 V, < 10 V Positive logic (source) PTI), < 0.6 V, > 2.5 V Positive logic (source) STOA, STOB), < 5 V, > 11 V
Analogue output number	1
Analogue output type	Software-configurable voltage AQ1 0...10 V DC 470 Ohm 10 bits Software-configurable current AQ1 0...20 mA 500 Ohm 10 bits
Input/output type	Programmable as logic input/output DQ1 0...1 kHz, <= 30 V DC, 100 mA Programmable as logic input/output DQ2 0...1 kHz, <= 30 V DC, 100 mA
Sampling duration	2 Ms +/- 0.5 ms DI1...DI5) - discrete input 5 Ms +/- 1 ms PTI) - pulse input 1 Ms +/- 1 ms AI1, AI2) - analog input 5 Ms +/- 1 ms AQ1) - analog output 2 ms +/- 0.5 ms DQ1, DQ2) - discrete input/output
Accuracy	+/- 0.6 % AI1, AI2 for a temperature variation 60 °C analog input +/- 1 % AQ1 for a temperature variation 60 °C analog output
Linearity error	AI1, AI2 +/- 0.15 % of maximum value analog input AQ1 +/- 0.2 % analog output
Relay output number	2
Relay output type	Configurable relay logic R1 fault relay NO/NC 100000 cycles Configurable relay logic R2 sequence relay NO 100000 cycles
Refresh time	Relay output R1, R2)5 ms +/- 0.5 ms)
Minimum switching current	Relay output R1, R2 5 mA 24 V DC
Maximum switching current	Relay output R1 resistive, cos phi = 1 3 A 250 V AC Relay output R1 resistive, cos phi = 1 3 A 30 V DC Relay output R1 inductive, cos phi = 0.4 7 ms 2 A 250 V AC Relay output R1 inductive, cos phi = 0.4 7 ms 2 A 30 V DC Relay output R2 resistive, cos phi = 1 5 A 250 V AC Relay output R2 resistive, cos phi = 1 5 A 30 V DC Relay output R2 inductive, cos phi = 0.4 7 ms 2 A 250 V AC Relay output R2 inductive, cos phi = 0.4 7 ms 2 A 30 V DC

Environment

Isolation	Between power and control terminals
Insulation resistance	> 1 MOhm 500 V DC for 1 minute to earth
Noise level	55.6 dB 86/188/EEC
Power dissipation in W	Natural convection 18 W 380 V 4 kHz heavy duty) Forced convection 346 W 380 V 4 kHz heavy duty) Natural convection 21 W 380 V 4 kHz normal duty) Forced convection 411 W 380 V 4 kHz normal duty)
Volume of cooling air	33814.63 Gal/hr(US) (128 m3/h)
Operating position	Vertical +/- 10 degree
Electromagnetic compatibility	Electrostatic discharge immunity test level 3 IEC 61000-4-2 Radiated radio-frequency electromagnetic field immunity test level 3 IEC 61000-4-3 Electrical fast transient/burst immunity test level 4 IEC 61000-4-4 1.2/50 µs - 8/20 µs surge immunity test level 3 IEC 61000-4-5 Conducted radio-frequency immunity test level 3 IEC 61000-4-6
Pollution degree	2 EN/IEC 61800-5-1
Vibration resistance	1.5 mm peak to peak 2...19 Hz)EN/IEC 60721-3-3 class 3M3 1 gn 9...200 Hz)EN/IEC 60721-3-3 class 3M3

Shock resistance	15 gn 11 ms, class 3M3 EN/IEC 60721-3-3
Relative humidity	5...95 % without condensation EN/IEC 60721-3-3 class 3K3
Ambient air temperature for operation	5...122 °F (-15...50 °C) without current derating heavy duty) 5...104 °F (-15...40 °C) without current derating normal duty) 122...140 °F (50...60 °C) with current derating heavy duty) 104...140 °F (40...60 °C) with current derating normal duty)
Ambient air temperature for storage	-40...158 °F (-40...70 °C)
Operating altitude	<= 3280.84 ft (1000 m) without 3280.84...9842.52 ft (1000...3000 m) with current derating 1 % per 100 m
Environmental characteristic	Chemical pollution resistance class 3C3 EN/IEC 60721-3-3 Dust pollution resistance class 3S3 EN/IEC 60721-3-3
Standards	EN/IEC 61800-3 Environment 1 category C2 EN/IEC 61800-3 Environment 2 category C3 EN/IEC 61800-3 EN/IEC 61800-5-1 IEC 60721-3 IEC 61508 IEC 13849-1 UL 618000-5-1
Product certifications	TÜV REACH CSA UL
Marking	CE

Ordering and shipping details

Category	22182 - ATV340 (1 THRU 25 HP)
Discount Schedule	CP4B
GTIN	00785901742968
Package weight(Lbs)	11.23 kg (24.75 lb(US))
Returnability	Yes
Country of origin	ID

Offer Sustainability

Sustainable offer status	Green Premium product
REACH Regulation	REACH Declaration
EU RoHS Directive	Pro-active compliance (Product out of EU RoHS legal scope) EU RoHS Declaration
Mercury free	Yes
RoHS exemption information	Yes
China RoHS Regulation	China RoHS Declaration
Environmental Disclosure	Product Environmental Profile
Circularity Profile	End Of Life Information
WEEE	The product must be disposed on European Union markets following specific waste collection and never end up in rubbish bins.

Dimensions

Views: Front - Left - Rear

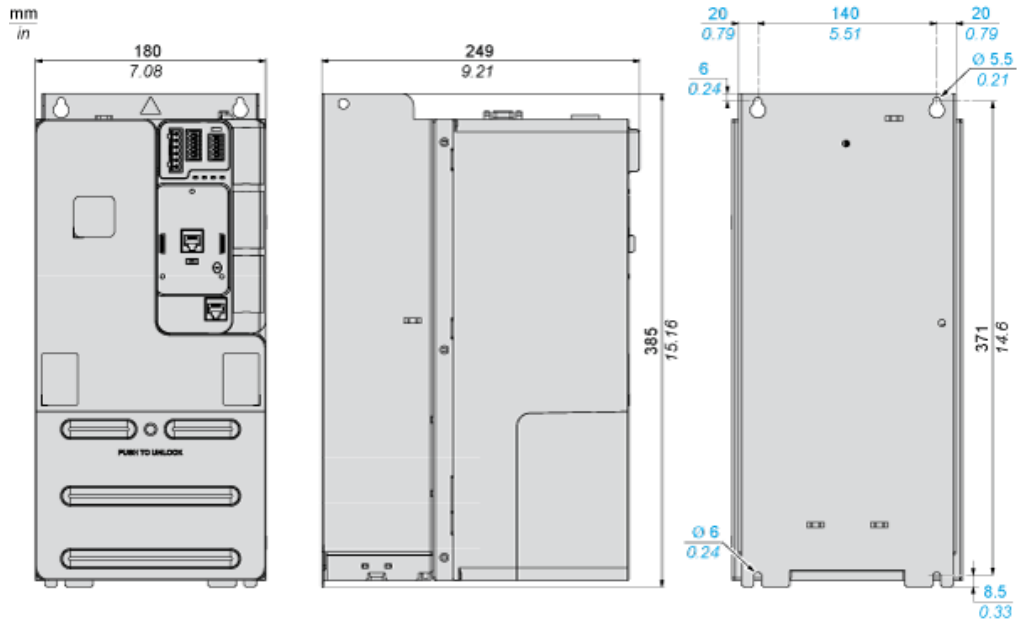

Clearance

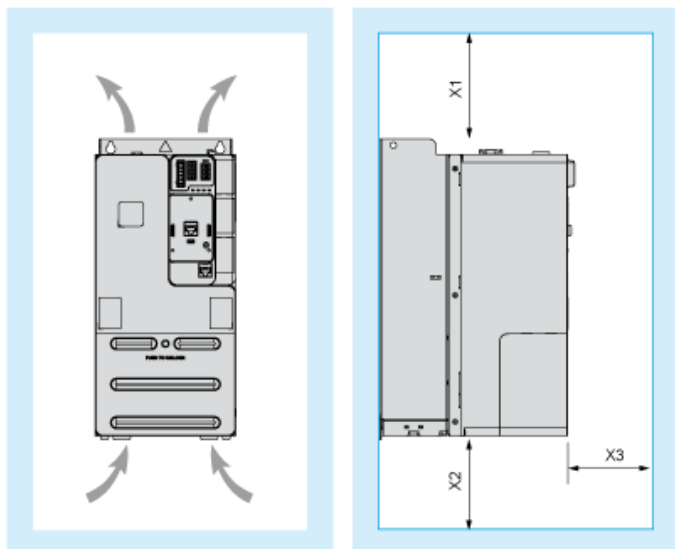

Dimensions in mm

X1	X2	X3
≥ 100	≥ 100	≥ 60

Dimensions in in.

X1	X2	X3
≥ 3.94	≥ 3.94	≥ 2.36

Mounting Types

Mounting Type A: Side by Side IP20

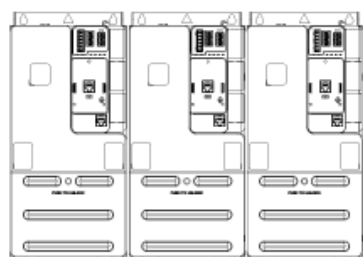

Possible, at ambient temperature ≤ 50 °C (122 °F)

Mounting Type B: Individual IP20

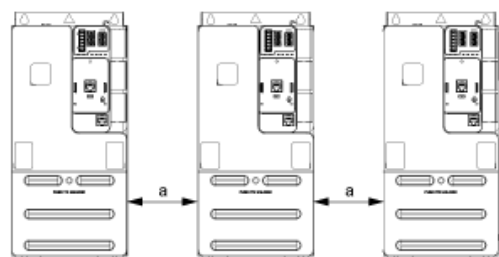

$a \geq 50 \text{ mm (1.97 in.)}$ from 50...60°C, no restriction below 50°C

Connections and Schema

Three-phase Power Supply with Upstream Breaking via Line Contactor Without Safety Function STO

Connection diagrams conforming to standards ISO13849 category 1 and IEC/EN 61508 capacity SIL1, stopping category 0 in accordance with standard IEC/EN 60204-1.



(1) Use relay output R1 set to operating state Fault to switch Off the product once an error is detected.

A1 : Drive

KM1 Line Contactor

Q2, Circuit breakers

Q3 :

S1 : Pushbutton

S2 : Emergency stop

T1 : Transformer for control part

Three-phase Power Supply With Downstream Breaking via Switch Disconnecter

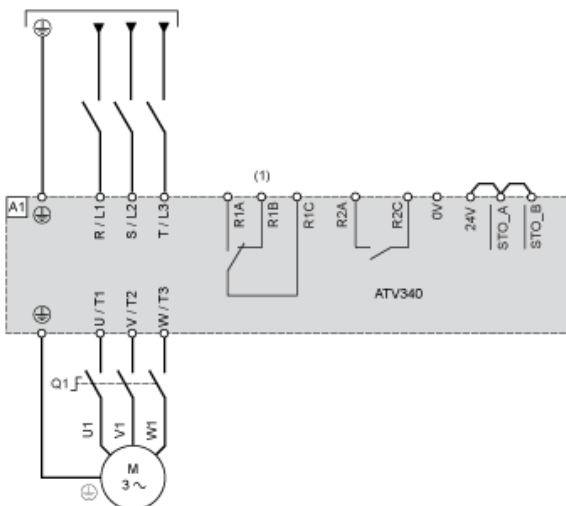

(1) Use relay output R1 set to operating state Fault to switch Off the product once an error is detected.

A1 : Drive

Q1 : Switch disconnecter

Sensor Connection



It is possible to connect either 1 or 3 sensors on terminals AI1.

Control Block Wiring Diagram



- (1) 24V supply (STO)
 - (2) STO - Safe Torque Off
 - (3) PTI - Pulse Train In
 - (4) PTO - Pulse Train Out
 - (5) Motor Encoder connection
 - (6) Digital outputs
 - (7) Digital inputs
 - (8) Analog output
 - (9) Analog input
 - (10) Differential Analog Input
 - (11) Ethernet port (only on Ethernet drive version)
- SW1 Sink/Source switch
R1A, Fault relay
R1B,
R1C :
R2A, Sequence relay
R2C :

Digital Inputs Wiring

Digital Inputs: Internal Supply

Using DISUP Signal

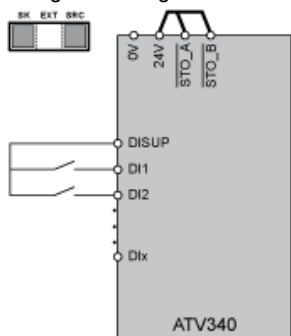

In SRC position DISUP outputs 24 V. In SK position DISUP is connected to 0 V.

Digital Inputs: External Supply

Positive Logic, Source, European Style

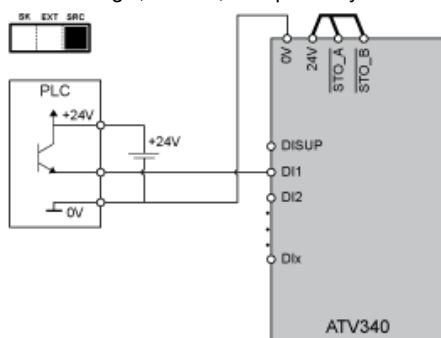

Negative Logic, Sink, Asian Style



Digital Inputs: Internal supply

Negative Logic, Sink, Asian Style

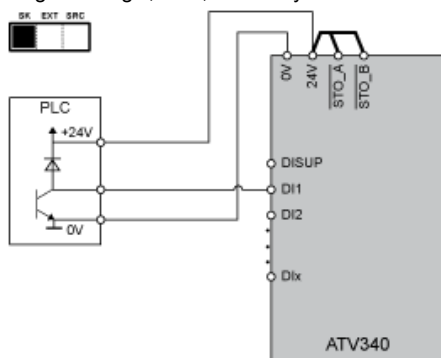

Digital Outputs Wiring

Digital Outputs: Internal Supply

Positive Logic, Source, European Style, DQCOM to +24V



(1) Relay or valve

Negative Logic, Sink, Asian Style, DQCOM to 0V



(1) Relay or valve

Digital Outputs: External Supply

Positive Logic, Source, European Style, DQCOM to +24V



(1) Relay or valve

Negative Logic, Sink, Asian Style, DQCOM to 0V



(1) Relay or valve

Open Loop Applications

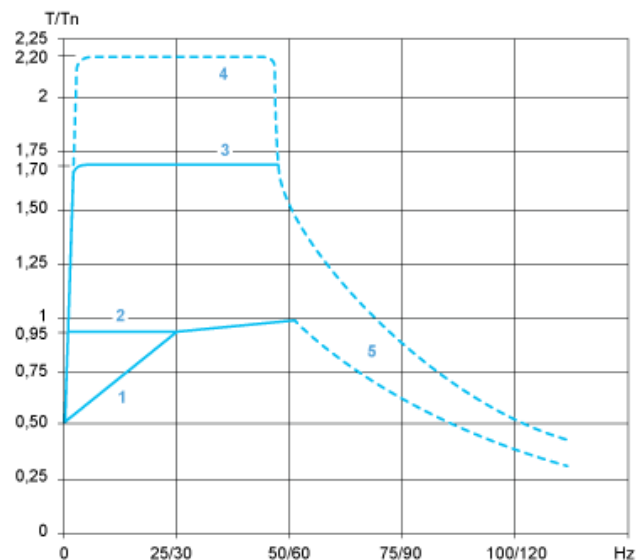

- 1 : Self-cooled motor: continuous useful torque
- 2 : Force-cooled motor: continuous useful torque
- 3 : Overtorque for 60 s maximum
- 4 : Transient overtorque for 2 s maximum
- 5 : Torque in overspeed at constant power

Closed Loop Applications



- 1 : Self-cooled motor: continuous useful torque
- 2 : Force-cooled motor: continuous useful torque
- 3 : Overtorque for 60 s maximum
- 4 : Transient overtorque for 2 s maximum
- 5 : Torque in overspeed at constant power