





## Main

Range of product	Altivar Process ATV900
Product or component type	Variable speed drive
Device application	Industrial application
Device short name	ATV930
Variant	With braking chopper Standard version
Product destination	Synchronous motors Asynchronous motors
Mounting mode	Wall mount
EMC filter	Without EMC filter
IP degree of protection	IP21 IEC 61800-5-1 IP21 IEC 60529
Degree of protection	UL type 1 UL 508C
Type of cooling	Forced convection
Supply frequency	50...60 Hz +/- 5 %
Phase	3 phase
[Us] rated supply voltage	200...240 V - 15...10 %
Motor power kW	30 kW normal duty) 22 kW heavy duty)
Maximum Horse Power Rating	40 Hp normal duty 30 hp heavy duty
Line current	104.7 A 200 V normal duty) 88.6 A 240 V normal duty) 78.3 A 200 V heavy duty) 67.1 A 240 V heavy duty)
Prospective line Isc	50 kA
Apparent power	36.8 KVA 240 V normal duty) 27.9 kVA 240 V heavy duty)
Continuous output current	123 A 2.5 kHz normal duty 92.6 A 2.5 kHz heavy duty
Maximum transient current	147.6 A 60 s normal duty) 138.9 A 60 s heavy duty)
Asynchronous motor control profile	Variable torque standard Optimized torque mode Constant torque standard
Synchronous motor control profile	Permanent magnet motor Synchronous reluctance motor
Speed drive output frequency	0.1...599 Hz
Nominal switching frequency	2.5 kHz
Switching frequency	1...8 kHz adjustable 2.5...8 kHz with derating factor
Safety function	STO (safe torque off) SIL 3
Number of preset speeds	16 preset speeds

Communication port protocol	Modbus TCP Modbus serial Ethernet/IP
Option module	Slot A communication module Profibus DP V1 Slot A communication module Profinet Slot A communication module DeviceNet Slot A communication module EtherCAT Slot A communication module CANopen daisy chain RJ45 Slot A communication module CANopen SUB-D 9 Slot A communication module CANopen screw terminals Slot A/slot B/slot C digital and analog I/O extension module Slot A/slot B/slot C output relay extension module Slot B 5/12 V digital encoder interface module Slot B analog encoder interface module Slot B resolver encoder interface module Communication module Ethernet Powerlink

## Complementary

Output voltage	<= power supply voltage
Motor slip compensation	Automatic whatever the load Adjustable Can be suppressed Not available in permanent magnet motor law
Acceleration and deceleration ramps	Linear adjustable separately from 0.01...9999 s
Braking to standstill	By DC injection
Protection type	Thermal protection motor Safe torque off motor Motor phase break motor Thermal protection drive Safe torque off drive Overheating drive Overcurrent between output phases and earth drive Overload of output voltage drive Short-circuit protection drive Motor phase break: drive Overvoltages on the DC bus drive Line supply overvoltage drive Line supply undervoltage drive Line supply phase loss drive Overspeed drive Break on the control circuit drive
Frequency resolution	Display unit 0.1 Hz Analog input 0.012/50 Hz
Electrical connection	Control screw terminal 0.5...1.5 mm <sup>2</sup> AWG 20...AWG 16 Line side screw terminal 70...120 mm <sup>2</sup> AWG 1/0...250 kcmil DC bus screw terminal 70...120 mm <sup>2</sup> AWG 1/0...250 kcmil Motor screw terminal 70...120 mm <sup>2</sup> AWG 2/0...250 kcmil
Connector type	2 RJ45 Ethernet IP/Modbus TCP on the control block 1 RJ45 Modbus serial on the control block
Physical interface	2-wire RS 485 Modbus serial
Transmission frame	RTU Modbus serial
Transmission rate	10/100 Mbit/s Ethernet IP/Modbus TCP 4.8, 9.6, 19.2, 38.4 kbit/s Modbus serial
Exchange mode	Half duplex, full duplex, autonegotiation Ethernet IP/Modbus TCP
Data format	8 bits, configurable odd, even or no parity Modbus serial
Type of polarization	No impedance Modbus serial
Number of addresses	1...247 Modbus serial
Method of access	Slave Modbus TCP
Supply	External supply for digital inputs 24 V DC 19...30 V), <1.25 mA overload and short-circuit protection Internal supply for reference potentiometer (1 to 10 kOhm) 10.5 V DC +/- 5 %, <10 mA overload and short-circuit protection Internal supply for digital inputs and STO 24 V DC 21...27 V), <200 mA overload and short-circuit protection
Local signalling	Local diagnostic 3 LED mono/dual colour) Embedded communication status 5 LED dual colour) Communication module status 2 LED dual colour) Presence of voltage 1 LED red)

Width	11.42 in (290 mm)
Height	36.30 in (922 mm)
Depth	12.81 in (325.5 mm)
Net weight	126.99 lb(US) (57.6 kg)
Analogue input number	3
Analogue input type	AI1, AI2, AI3 software-configurable voltage 0...10 V DC 30 kOhm 12 bits AI1, AI2, AI3 software-configurable current 0...20 mA/4...20 mA 250 Ohm 12 bits
Discrete input number	10
Discrete input type	DI1...DI8 programmable, 24 V DC <= 30 V)3.5 kOhm DI7, DI8 programmable as pulse input 0...30 kHz, 24 V DC <= 30 V) STOA, STOB safe torque off, 24 V DC <= 30 V)> 2.2 kOhm
Input compatibility	DI1...DI8 discrete input level 1 PLC EN/IEC 61131-2 DI7, DI8 pulse input level 1 PLC IEC 65A-68 STOA, STOB discrete input level 1 PLC EN/IEC 61131-2
Discrete input logic	Positive logic (source) DI1...DI8), < 5 V, > 11 V Negative logic (sink) DI1...DI8), > 16 V, < 10 V Positive logic (source) DI7, DI8), < 0.6 V, > 2.5 V Positive logic (source) STOA, STOB), < 5 V, > 11 V
Analogue output number	2
Analogue output type	Software-configurable voltage AQ1, AQ2 0...10 V DC 470 Ohm 10 bits Software-configurable current AQ1, AQ2 0...20 mA 500 Ohm 10 bits
Discrete output number	2
Discrete output type	Logic output DQ+ 0...1 kHz <= 30 V DC 100 mA Programmable as pulse output DQ+ 0...30 kHz <= 30 V DC 20 mA Logic output DQ- 0...1 kHz <= 30 V DC 100 mA
Sampling duration	2 Ms +/- 0.5 ms DI1...DI8) - discrete input 5 Ms +/- 1 ms DI7, DI8) - pulse input 1 Ms +/- 1 ms AI1, AI2, AI3) - analog input 5 ms +/- 1 ms AQ1, AQ2) - analog output
Accuracy	+/- 0.6 % AI1, AI2, AI3 for a temperature variation 60 °C analog input +/- 1 % AQ1, AQ2 for a temperature variation 60 °C analog output
Linearity error	AI1, AI2, AI3 +/- 0.15 % of maximum value analog input AQ1, AQ2 +/- 0.2 % analog output
Maximum switching current	Relay output R1 resistive, cos phi = 1 3 A 250 V AC Relay output R1 resistive, cos phi = 1 3 A 30 V DC Relay output R1 inductive, cos phi = 0.4 7 ms 2 A 250 V AC Relay output R1 inductive, cos phi = 0.4 7 ms 2 A 30 V DC Relay output R2, R3 resistive, cos phi = 1 5 A 250 V AC Relay output R2, R3 resistive, cos phi = 1 5 A 30 V DC Relay output R2, R3 inductive, cos phi = 0.4 7 ms 2 A 250 V AC Relay output R2, R3 inductive, cos phi = 0.4 7 ms 2 A 30 V DC
Relay output number	3
Relay output type	Configurable relay logic R1 fault relay NO/NC 100000 cycles Configurable relay logic R2 sequence relay NO 1000000 cycles Configurable relay logic R3 sequence relay NO 1000000 cycles
Refresh time	Relay output R1, R2, R3)5 ms +/- 0.5 ms)
Minimum switching current	Relay output R1, R2, R3 5 mA 24 V DC
Isolation	Between power and control terminals
Variable speed drive application selection	Food and beverage processing Mixer Food and beverage processing Conveyor Food and beverage processing Shredder Hoisting Process crane Marine Thruster Marine Winch Material working (wood, ceramic, stone, pvc, metal) Press Material working (wood, ceramic, stone, pvc, metal) Extruder Mining mineral and metal Other application Oil and gas Drilling rig Oil and gas Progressive cavity pump Oil and gas Rod pump Oil and gas Swapping pump Oil and gas Compressor for regasification Oil and gas Separator Oil and gas Other application Water and waste water Separator
Power range	30...50 kW 200...240 V 3 phase

## Environment

Insulation resistance	> 1 MOhm 500 V DC for 1 minute to earth
Noise level	68.3 dB 86/188/EEC
Power dissipation in W	Natural convection 129 W 200 V 2.5 kHz Forced convection 862 W 200 V 2.5 kHz
Vibration resistance	1.5 mm peak to peak 2...13 Hz)IEC 60068-2-6 1 gn 13...200 Hz)IEC 60068-2-6
Shock resistance	15 gn 11 ms IEC 60068-2-27
Volume of cooling air	77932.15 Gal/hr(US) (295 m3/h)
Operating position	Vertical +/- 10 degree
Maximum THDI	<48 % from 80...100 % of load IEC 61000-3-12
Electromagnetic compatibility	Electrostatic discharge immunity test level 3 IEC 61000-4-2 Radiated radio-frequency electromagnetic field immunity test level 3 IEC 61000-4-3 Electrical fast transient/burst immunity test level 4 IEC 61000-4-4 1.2/50 µs - 8/20 µs surge immunity test level 3 IEC 61000-4-5 Conducted radio-frequency immunity test level 3 IEC 61000-4-6
Environmental characteristic	Chemical pollution resistance class 3C3 EN/IEC 60721-3-3 Dust pollution resistance class 3S3 EN/IEC 60721-3-3
Pollution degree	2 EN/IEC 61800-5-1
Relative humidity	5...95 % without condensation IEC 60068-2-3
Ambient air temperature for operation	5...122 °F (-15...50 °C) without) 122...140 °F (50...60 °C) with derating factor)
Ambient air temperature for storage	-40...158 °F (-40...70 °C)
Operating altitude	<= 3280.84 ft (1000 m) without 1000...4800 m with current derating 1 % per 100 m
Standards	UL 508C EN/IEC 61800-3 Environment 1 category C2 EN/IEC 61800-3 Environment 2 category C3 EN/IEC 61800-3 EN/IEC 61800-5-1 IEC 61000-3-12 IEC 60721-3 IEC 61508 IEC 13849-1
Product certifications	TÜV UL REACH CSA
Marking	CE

## Ordering and shipping details

Category	22277 - ATV930 FRAMES 3 & 4
Discount Schedule	CP4E
GTIN	00785901772392
Package weight(Lbs)	60.19 kg (132.7 lb(US))
Returnability	Yes
Country of origin	CN

## Offer Sustainability

Sustainable offer status	Green Premium product
California proposition 65	WARNING: This product can expose you to chemicals including: Lead and lead compounds which is known to the State of California to cause Carcinogen & Reproductive harm. For more information go to <a href="http://www.p65warnings.ca.gov">www.p65warnings.ca.gov</a>
REACH Regulation	<a href="#">REACH Declaration</a>
EU RoHS Directive	Pro-active compliance (Product out of EU RoHS legal scope) <a href="#">EU RoHS Declaration</a>
Mercury free	Yes
RoHS exemption information	<a href="#">Yes</a>
China RoHS Regulation	<a href="#">China RoHS Declaration</a>

---

Environmental Disclosure	<a href="#">Product Environmental Profile</a>
Circularity Profile	<a href="#">End Of Life Information</a>
WEEE	The product must be disposed on European Union markets following specific waste collection and never end up in rubbish bins.

---

## Dimensions

### IP21 / UL Type 1 Drives - Front and Left Side View

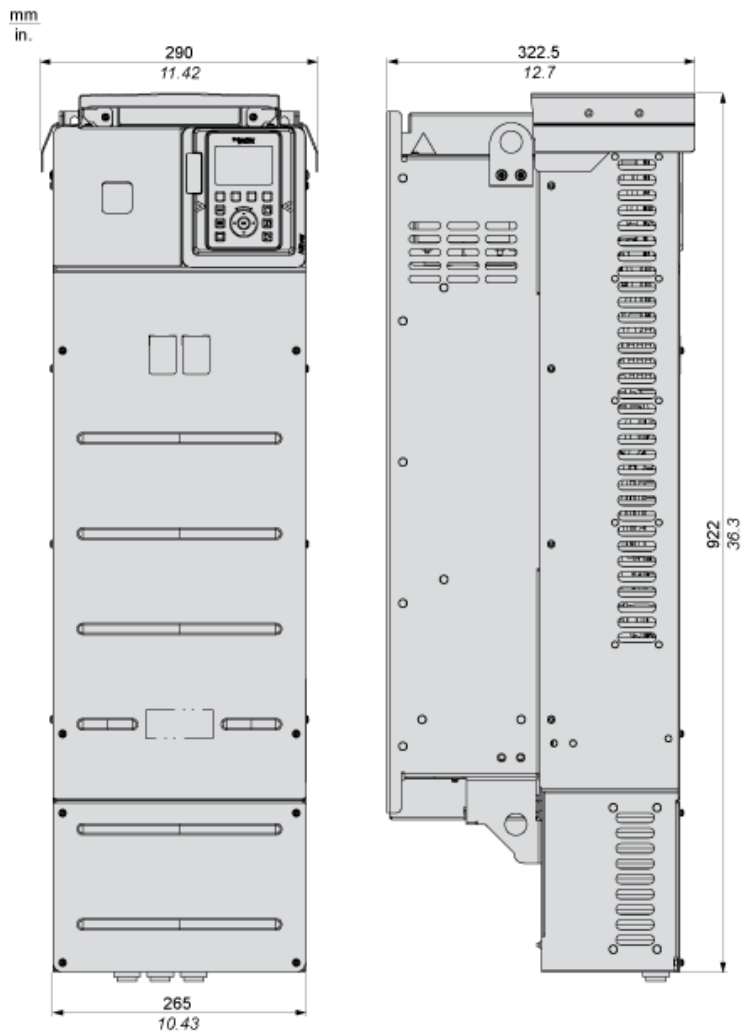

## Drives without IP21 Top Cover - Rear View

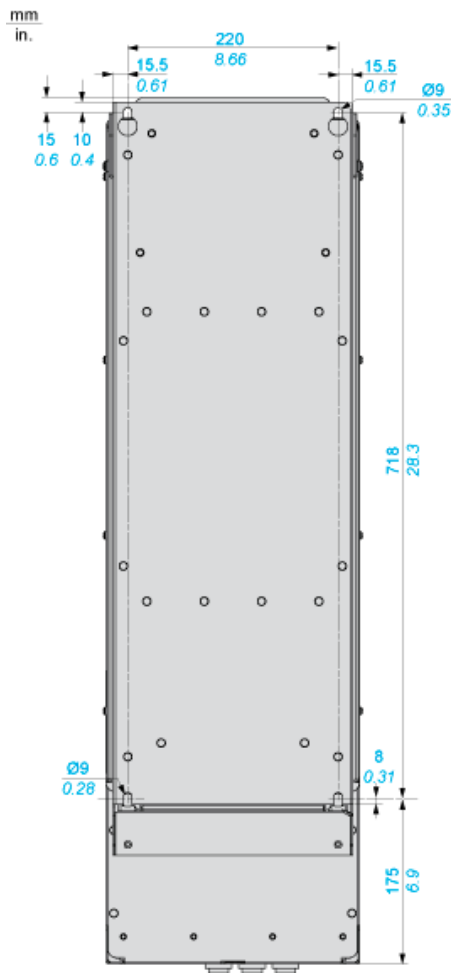



Clearances

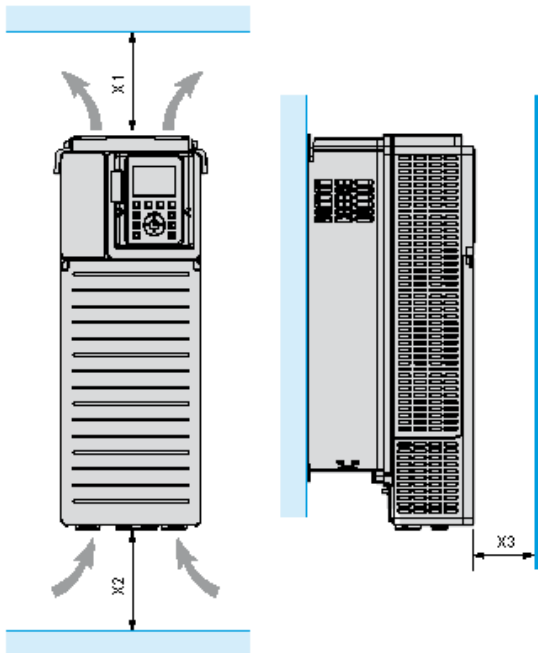

X1	X2	X3
≥ 100 mm (3.94 in.)	≥ 100 mm (3.94 in.)	≥ 10 mm (0.39 in.)

- Mount the device in a vertical position ( $\pm 10^\circ$ ). This is required for cooling the device.
- Do not mount the device close to heat sources.
- Leave sufficient free space so that the air required for cooling purposes can circulate from the bottom to the top of the drive.

Mounting Types

Mounting Type A: Individual IP21

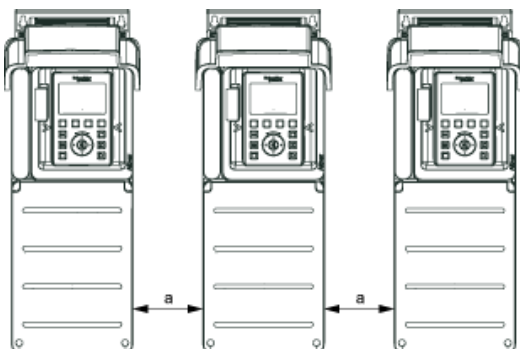

$a \geq 110 \text{ mm (4.33 in.)}$

Mounting Type B: Side by Side IP20 (Possible, 2 Drives Only)

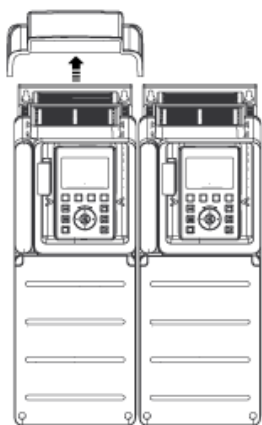

Mounting Type C: Individual IP20

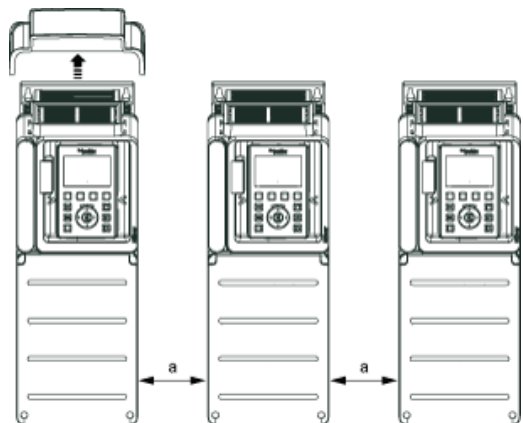

$a \geq 110 \text{ mm (4.33 in.)}$