





Main

Range of product	Altivar Process ATV900
Product or component type	Variable speed drive
Device application	Industrial application
Device short name	ATV930
Variant	Standard version With braking chopper
Product destination	Asynchronous motors Synchronous motors
Mounting mode	Wall mount
EMC filter	Integrated 82.02 ft (25 m) EN/IEC 61800-3 category C3
IP degree of protection	IP00 IEC 61800-5-1 IP00 IEC 60529 IP20 IEC 61800-5-1 with kit VW3A9705 IP20 IEC 60529 with kit VW3A9705
Type of cooling	Forced convection
Supply frequency	50...60 Hz +/- 5 %
Phase	3 phase
[Us] rated supply voltage	500...690 V - 15...10 %
Motor power kW	15 KW 500 V normal duty) 11 KW 500 V heavy duty) 18.5 KW 690 V normal duty) 15 kW 690 V heavy duty)
Maximum Horse Power Rating	20 Hp 500 V normal duty 15 Hp 500 V heavy duty 25 Hp 690 V normal duty 20 hp 690 V heavy duty
Line current	23.1 A 500 V normal duty) 23 A 690 V normal duty) 18.4 A 500 V heavy duty) 19.2 A 690 V heavy duty)
Prospective line Isc	70 kA
Apparent power	27.5 KVA 690 V normal duty) 22.9 kVA 690 V heavy duty)
Continuous output current	18 A 4 kHz heavy duty 24 A 4 kHz normal duty
Maximum transient current	27 A 60 s heavy duty) 28.8 A 60 s normal duty)
Asynchronous motor control profile	Optimized torque mode Constant torque standard Variable torque standard
Synchronous motor control profile	Permanent magnet motor Synchronous reluctance motor
Speed drive output frequency	0.1...599 Hz
Nominal switching frequency	4 kHz
Switching frequency	2...8 kHz adjustable 4...8 kHz with derating factor
Safety function	STO (safe torque off) SIL 3
Number of preset speeds	16 preset speeds

Communication port protocol	Modbus TCP Modbus serial Ethernet/IP
Option module	Slot A communication module Profibus DP V1 Slot A communication module Profinet Slot A communication module DeviceNet Slot A communication module EtherCAT Slot A communication module CANopen daisy chain RJ45 Slot A communication module CANopen SUB-D 9 Slot A communication module CANopen screw terminals Slot A/slot B/slot C digital and analog I/O extension module Slot A/slot B/slot C output relay extension module Slot B 5/12 V digital encoder interface module Slot B analog encoder interface module Slot B resolver encoder interface module Communication module Ethernet Powerlink

Complementary

Output voltage	\leq power supply voltage
Motor slip compensation	Can be suppressed Adjustable Not available in permanent magnet motor law Automatic whatever the load
Acceleration and deceleration ramps	Linear adjustable separately from 0.01...9999 s S, U or customized
Braking to standstill	By DC injection
Protection type	Thermal protection motor Safe torque off motor Motor phase break motor Thermal protection drive Safe torque off drive Overheating drive Overcurrent between output phases and earth drive Overload of output voltage drive Short-circuit protection drive Motor phase break: drive Overvoltages on the DC bus drive Line supply overvoltage drive Line supply undervoltage drive Line supply phase loss drive Overspeed drive Break on the control circuit drive
Frequency resolution	Display unit 0.1 Hz Analog input 0.012/50 Hz
Electrical connection	Control screw terminal 0.5...1.5 mm ² AWG 20...AWG 16 Motor screw terminal 6...10 mm ² AWG 10...AWG 8 DC bus screw terminal 6...10 mm ² AWG 10...AWG 8 Line side screw terminal 6...10 mm ² AWG 10...AWG 8
Connector type	2 RJ45 Ethernet IP/Modbus TCP on the control block 1 RJ45 Modbus serial on the control block
Physical interface	2-wire RS 485 Modbus serial
Transmission frame	RTU Modbus serial
Transmission rate	10/100 Mbit/s Ethernet IP/Modbus TCP 4.8, 9.6, 19.2, 38.4 kbit/s Modbus serial
Exchange mode	Half duplex, full duplex, autonegotiation Ethernet IP/Modbus TCP
Data format	8 bits, configurable odd, even or no parity Modbus serial
Type of polarization	No impedance Modbus serial
Number of addresses	1...247 Modbus serial
Method of access	Slave Modbus TCP
Supply	External supply for digital inputs 24 V DC 19...30 V), <1.25 mA overload and short-circuit protection Internal supply for reference potentiometer (1 to 10 kOhm) 10.5 V DC +/- 5 %, <10 mA overload and short-circuit protection Internal supply for digital inputs and STO 24 V DC 21...27 V), <200 mA overload and short-circuit protection

Local signalling	Local diagnostic 3 LED mono/dual colour) Presence of voltage 1 LED red) Embedded communication status 3 LED dual colour) Communication module status 4 LED dual colour)
Width	9.69 in (246 mm)
Height	16.54 in (420 mm)
Depth	9.53 in (242 mm)
Net weight	48.50 lb(US) (22 kg)
Analogue input number	3
Analogue input type	AI1, AI2, AI3 software-configurable voltage 0...10 V DC 30 kOhm 12 bits AI1, AI2, AI3 software-configurable current 0...20 mA/4...20 mA 250 Ohm 12 bits
Discrete input number	10
Discrete input type	DI1...DI8 programmable, 24 V DC <= 30 V)3.5 kOhm DI7, DI8 programmable as pulse input 0...30 kHz, 24 V DC <= 30 V) STOA, STOB safe torque off, 24 V DC <= 30 V)> 2.2 kOhm
Input compatibility	DI1...DI8 discrete input level 1 PLC EN/IEC 61131-2 DI7, DI8 pulse input level 1 PLC IEC 65A-68 STOA, STOB discrete input level 1 PLC EN/IEC 61131-2
Discrete input logic	Positive logic (source) DI1...DI8), < 5 V, > 11 V Negative logic (sink) DI1...DI8), > 16 V, < 10 V Positive logic (source) DI7, DI8), < 0.6 V, > 2.5 V Positive logic (source) STOA, STOB), < 5 V, > 11 V
Analogue output number	2
Analogue output type	Software-configurable voltage AQ1, AQ2 0...10 V DC 470 Ohm 10 bits Software-configurable current AQ1, AQ2 0...20 mA 500 Ohm 10 bits
Discrete output number	2
Discrete output type	Logic output DQ+ 0...1 kHz <= 30 V DC 100 mA Programmable as pulse output DQ+ 0...30 kHz <= 30 V DC 20 mA Logic output DQ- 0...1 kHz <= 30 V DC 100 mA
Sampling duration	2 Ms +/- 0.5 ms DI1...DI8) - discrete input 5 Ms +/- 1 ms DI7, DI8) - pulse input 1 Ms +/- 1 ms AI1, AI2, AI3) - analog input 5 ms +/- 1 ms AQ1, AQ2) - analog output
Accuracy	+/- 0.6 % AI1, AI2, AI3 for a temperature variation 60 °C analog input +/- 1 % AQ1, AQ2 for a temperature variation 60 °C analog output
Linearity error	AI1, AI2, AI3 +/- 0.15 % of maximum value analog input AQ1, AQ2 +/- 0.2 % analog output
Maximum switching current	Relay output R1 resistive, cos phi = 1 3 A 250 V AC Relay output R1 resistive, cos phi = 1 3 A 30 V DC Relay output R1 inductive, cos phi = 0.4 7 ms 2 A 250 V AC Relay output R1 inductive, cos phi = 0.4 7 ms 2 A 30 V DC Relay output R2, R3 resistive, cos phi = 1 5 A 250 V AC Relay output R2, R3 resistive, cos phi = 1 5 A 30 V DC Relay output R2, R3 inductive, cos phi = 0.4 7 ms 2 A 250 V AC Relay output R2, R3 inductive, cos phi = 0.4 7 ms 2 A 30 V DC
Relay output number	3
Relay output type	Configurable relay logic R1 fault relay NO/NC 100000 cycles Configurable relay logic R2 sequence relay NO 1000000 cycles Configurable relay logic R3 sequence relay NO 1000000 cycles
Refresh time	Relay output R1, R2, R3)5 ms +/- 0.5 ms)
Minimum switching current	Relay output R1, R2, R3 5 mA 24 V DC
Isolation	Between power and control terminals

Environment

Insulation resistance	> 1 MOhm 500 V DC for 1 minute to earth
Noise level	58 dB 86/188/EEC
Power dissipation in W	Forced convection 376 W 500 V 4 kHz Natural convection 124 W 500 V 4 kHz
Vibration resistance	1.5 mm peak to peak 2...13 Hz)IEC 60068-2-6 1 gn 13...200 Hz)IEC 60068-2-6
Shock resistance	15 gn 11 ms IEC 60068-2-27
Volume of cooling air	87178.34 Gal/hr(US) (330 m3/h)
Operating position	Vertical +/- 10 degree

Electromagnetic compatibility	Electrostatic discharge immunity test level 3 IEC 61000-4-2 Radiated radio-frequency electromagnetic field immunity test level 3 IEC 61000-4-3 Electrical fast transient/burst immunity test level 4 IEC 61000-4-4 1.2/50 µs - 8/20 µs surge immunity test level 3 IEC 61000-4-5 Conducted radio-frequency immunity test level 3 IEC 61000-4-6
Environmental characteristic	Chemical pollution resistance class 3C3 EN/IEC 60721-3-3 Dust pollution resistance class 3S3 EN/IEC 60721-3-3
Pollution degree	2 EN/IEC 61800-5-1
Relative humidity	5...95 % without condensation IEC 60068-2-3
Ambient air temperature for operation	5...122 °F (-15...50 °C) without 122...140 °F (50...60 °C) with derating factor)
Ambient air temperature for storage	-40...158 °F (-40...70 °C)
Operating altitude	<= 3280.84 ft (1000 m) without 1000...4800 m with current derating 1 % per 100 m
Standards	UL 508C EN/IEC 61800-3 Environment 2 category C3 EN/IEC 61800-3 EN/IEC 61800-5-1 IEC 61000-3-12 IEC 60721-3 IEC 61508 IEC 13849-1
Product certifications	CSA UL TÜV REACH
Marking	CE

Ordering and shipping details

Category	22276 - ATV930 FRAMES 1 & 2
Discount Schedule	CP4E
GTIN	00785901022589
Package weight(Lbs)	9525.43 kg (21000 lb(US))
Returnability	Yes
Country of origin	IN

Offer Sustainability

Sustainable offer status	Green Premium product
California proposition 65	WARNING: This product can expose you to chemicals including: Lead and lead compounds which is known to the State of California to cause Carcinogen & Reproductive harm. For more information go to www.p65warnings.ca.gov
REACH Regulation	REACH Declaration
EU RoHS Directive	Pro-active compliance (Product out of EU RoHS legal scope) EU RoHS Declaration
Mercury free	Yes
RoHS exemption information	Yes
China RoHS Regulation	China RoHS Declaration
Environmental Disclosure	Product Environmental Profile
Circularity Profile	End Of Life Information
WEEE	The product must be disposed on European Union markets following specific waste collection and never end up in rubbish bins.

Dimensions

Drives without Top Cover

Front View with EMC Plate, Front, Left and Rear View without EMC Plate

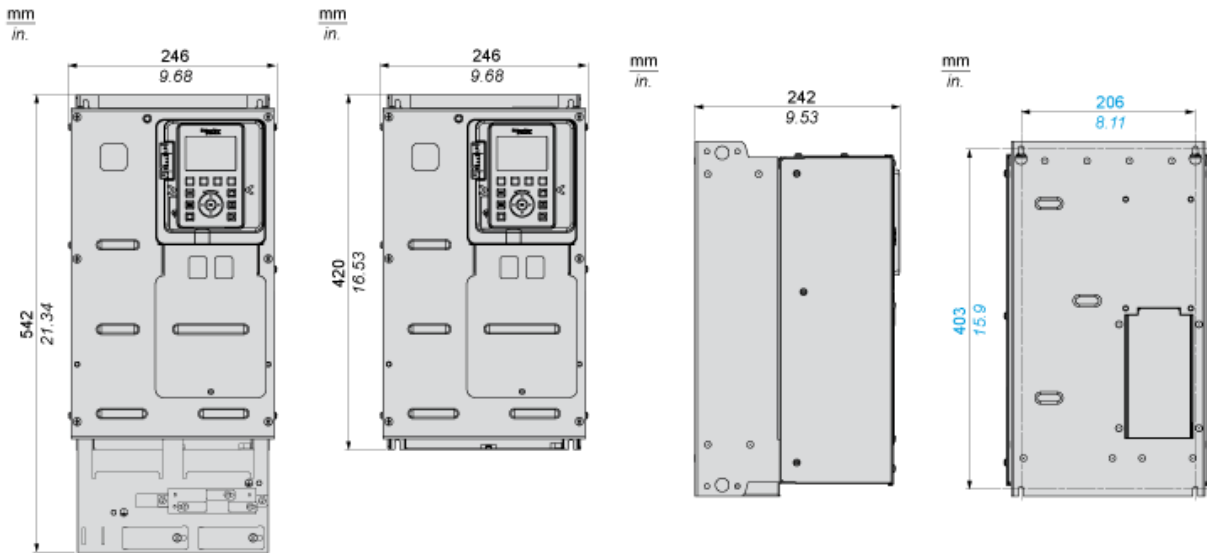

Drives with IP20 Top Cover

Front, Left and Rear View

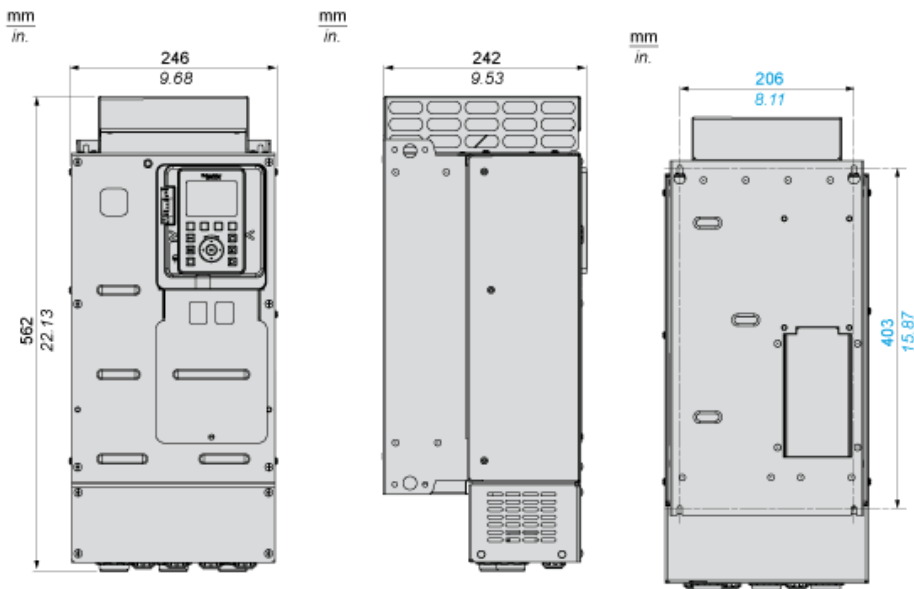

Clearances

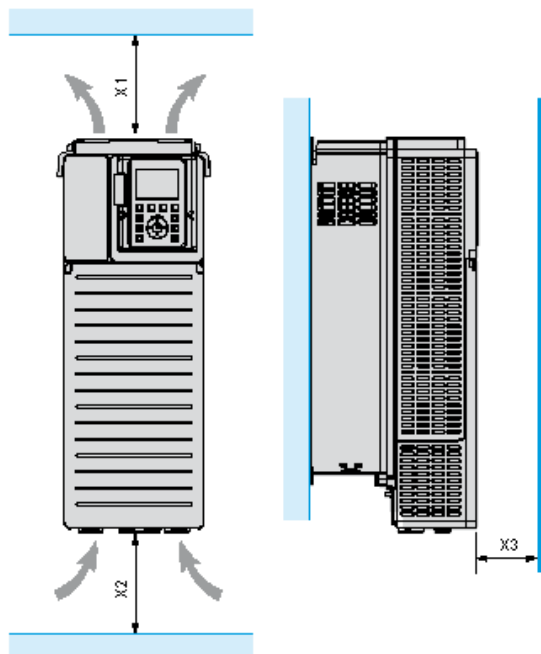

X1	X2	X3
≥ 100 mm (3.94 in.)	≥ 100 mm (3.94 in.)	≥ 10 mm (0.39 in.)

- Mount the device in a vertical position ($\pm 10^\circ$). This is required for cooling the device.
- Do not mount the device close to heat sources.
- Leave sufficient free space so that the air required for cooling purposes can circulate from the bottom to the top of the drive.

Mounting Types

Mounting Type A: Individual IP21

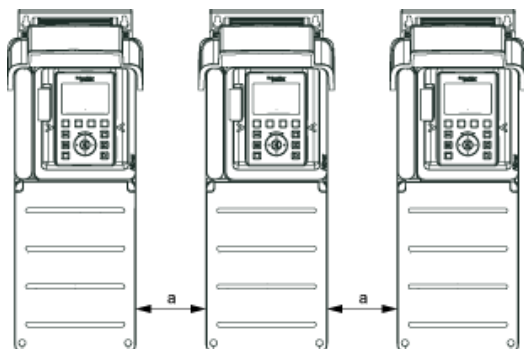

$a \geq 0$

Mounting Type B: Side by Side IP20

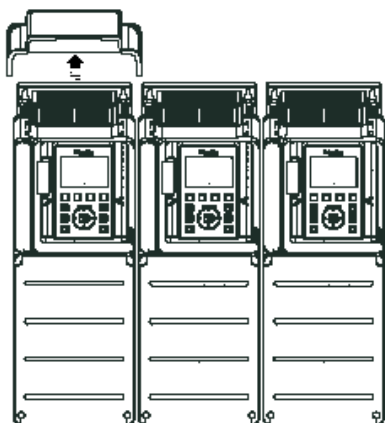

Mounting Type C: Individual IP20

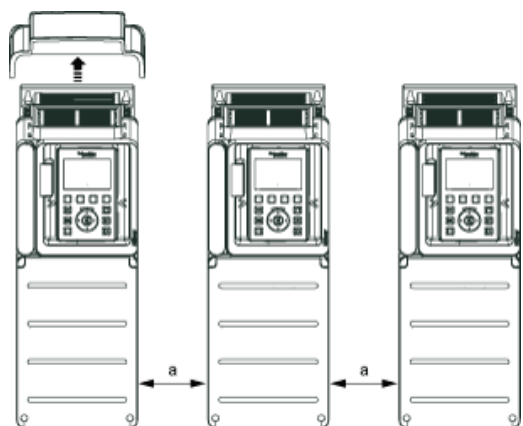

$a \geq 0$

Three-Phase Power Supply with Upstream Breaking via Line Contactor

Connection diagrams conforming to standards EN 954-1 category 1 and IEC/EN 61508 capacity SIL1, stopping category 0 in accordance with standard IEC/EN 60204-1

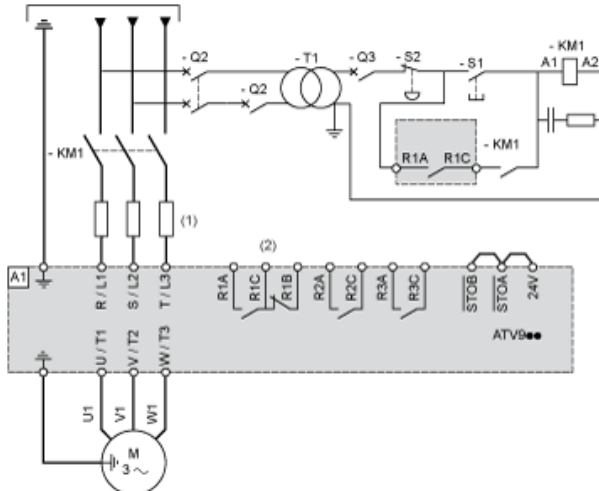

- (1) Line choke if used
- (2) Use relay R1 set to operating state Fault to switch Off the product once an error is detected.
- A1 : Drive
- KM1 Line Contactor
- Q2, Circuit breakers
- Q3 :
- S1, Pushbuttons
- S2 :
- T1 : Transformer for control part

Three-Phase Power Supply with Downstream Breaking via Contactor

Connection diagrams conforming to standards EN 954-1 category 1 and IEC/EN 61508 capacity SIL1, stopping category 0 in accordance with standard IEC/EN 60204-1

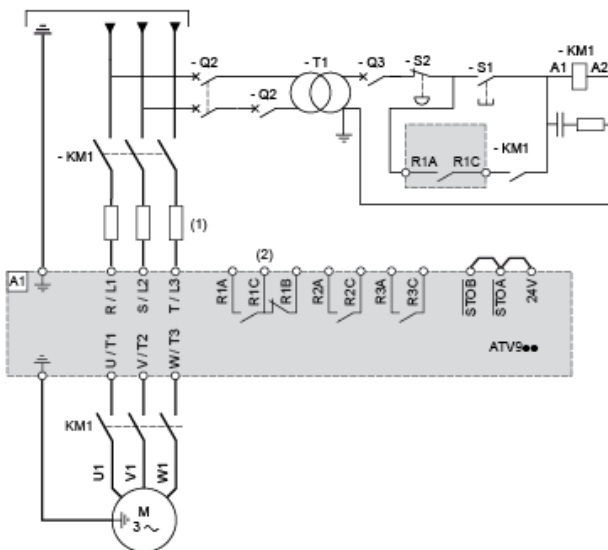

- (1) Line choke if used
- (2) Use relay R1 set to operating state Fault to switch Off the product once an error is detected.
- A1 : Drive
- KM1 Contactor

Control Block Wiring Diagram

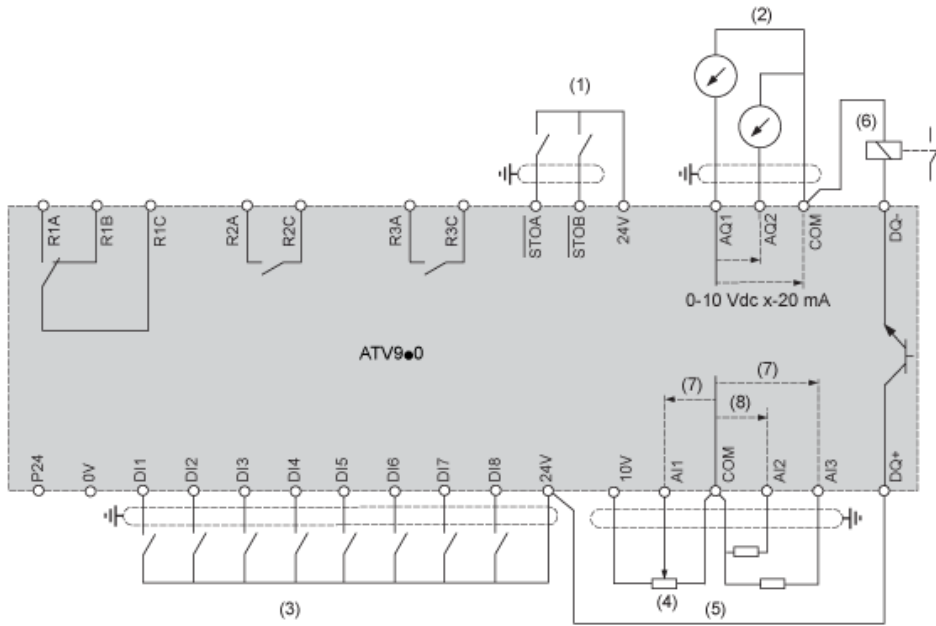

- (1) Safe Torque Off
 - (2) Analog Output
 - (3) Digital Input
 - (4) Reference potentiometer
 - (5) Analog Input
 - (6) Digital Output
 - (7) 0-10 Vdc, x-20 mA
 - (8) 0-10 Vdc, -10 Vdc...+10 Vdc
- R1A, Fault relay
 R1B,
 R1C :
 R2A, Sequence relay
 R2C :
 R3A, Sequence relay
 R3C :

Sensor Connection

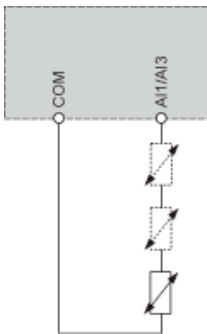

It is possible to connect either 1 or 3 sensors on terminals AI1 or AI3

Sink / Source Switch Configuration

The switch is used to adapt the operation of the logic inputs to the technology of the programmable controller outputs.

- Set the switch to Source (factory setting) if using PLC outputs with PNP transistors.
- Set the switch to Ext if using PLC outputs with NPN transistors.

Switch Set to SRC (Source) Position Using the Output Power Supply for the Digital Inputs

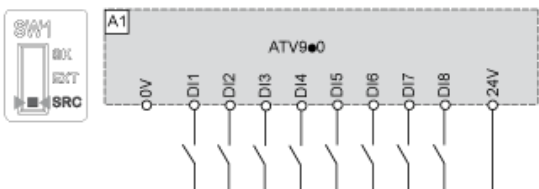

Switch Set to SRC (Source) Position and Use of an External Power Supply for the DIs

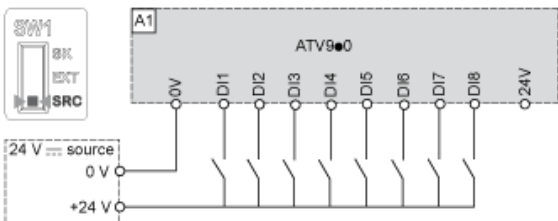

Switch Set to SK (Sink) Position Using the Output Power Supply for the Digital Inputs

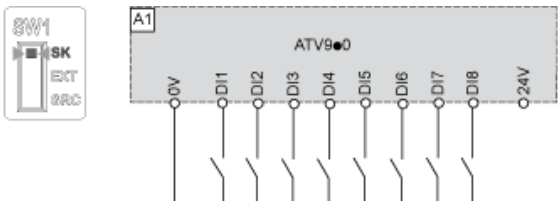

Switch Set to EXT Position Using an External Power Supply for the DIs

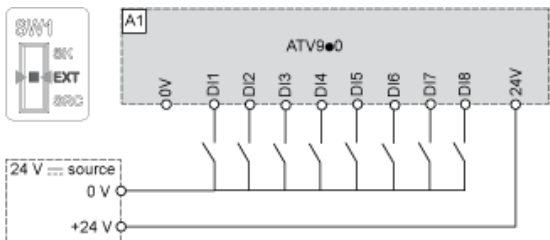

Derating Curves

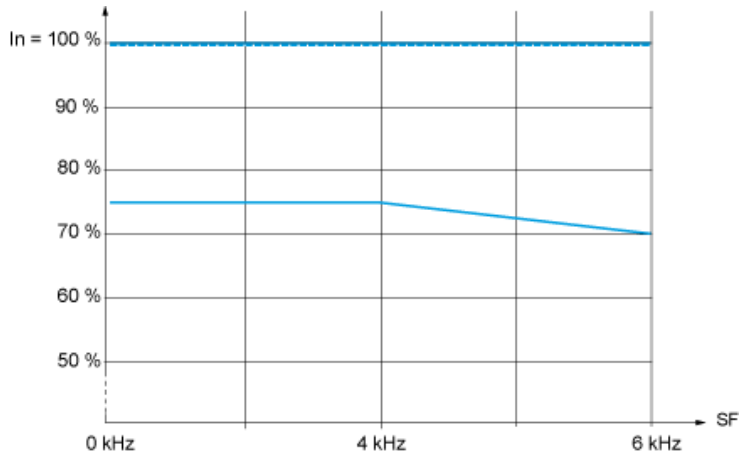

— 40 °C (104 °F) - Mounting type A, B and C
- - - 50 °C (122 °F) - Mounting type A, B and C
— 60 °C (140 °F) - Mounting type B and C
In : Nominal Drive Current
SF : Switching Frequency