

FEMALE END VIEW

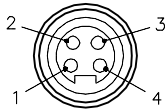

- 1 = BLACK
- 2 = WHITE
- 3 = RED
- 4 = GREEN



SPECIFICATIONS

CONTACT CARRIER MATERIAL	TPU/BLACK
CONTACT MATERIAL/PLATING	BRASS/GOLD
HOUSING MATERIAL/COLOR	BRASS/NICKEL
O-RING MATERIAL	BUNA-N
RATED CURRENT [A]	10.0 A
RATED VOLTAGE [V]	600 V
CONDUCTOR INSULATION MATERIAL	PVC
NUMBERS OF CONDUCTORS [AWG]	4x16 AWG
TEMPERATURE RATING	-40°C to +105°C (-40°F to +221°F)
PROTECTION CLASS	MEETS NEMA 1,3,4,6P AND IEC IP67

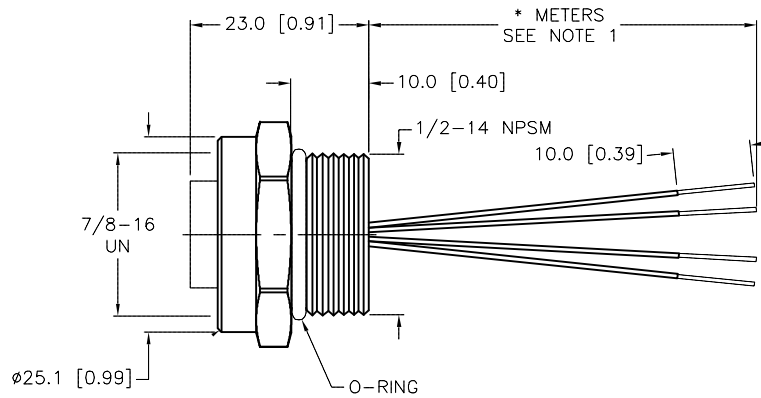

CABLE LENGTH	TOLERANCE*
ALL LENGTHS	+ 4% (OR 50mm) OF LENGTH - 0% (OR 0mm) OF LENGTH WHICHEVER IS GREATER
STRIP LENGTH	TOLERANCE*
0-7mm	±0.5mm
8-29mm	±1.0mm
30-49mm	±2.0mm
50-69mm	±3.0mm
70-100mm	±4.0mm
OVER 100mm	±5.0mm

\* UNLESS OTHERWISE SPECIFIED

NOTES:

- "\*" INDICATES CABLE LENGTH IN METERS. CONTACT TURCK TO ORDER SPECIFIC LENGTHS.

SOURCE DRAWING - FOR REFERENCE ONLY

RELATED DOCUMENTS 1. 2. 3. 4.	3RD ANGLE PROJECTION 	THIS DRAWING IS CONFIDENTIAL AND THE PROPERTY OF TURCK INC. USE OF THIS DOCUMENT WITHOUT WRITTEN PERMISSION IS PROHIBITED.		3000 CAMPUS DRIVE MINNEAPOLIS, MN 55441 1-800-544-7769 (763) 553-7300 (763) 553-0708 fax turck.com	
	MATERIAL  SEE SPECIFICATIONS	DRFT MJM	DATE 01/03/07	DESCRIPTION  RKF 46-*M	
FINISH  SEE SPECIFICATIONS	ALL DIMENSIONS DISPLAYED ON THIS DRAWING ARE FOR REFERENCE ONLY	DSGN	SCALE 1=1.0	IDENTIFICATION NO.	
		UNIT OF MEASUREMENT <b>MILLIMETER [ INCH ]</b>		REV <b>B</b>	
DO NOT SCALE THIS DRAWING		FILE: 777003071		SHEET 1 OF 1	

B	UPDATE RATED CURRENT FROM 9.0 A TO 10.0 A, SEE ECO	RWC	02/03/10	29831
REV	DESCRIPTION	BY	DATE	ECO NO.