

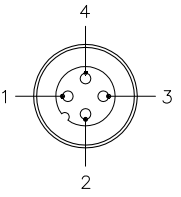

MALE END VIEW	FEMALE END VIEW	WIRING DIAGRAM	SPECIFICATIONS																	
		 <p>PICOFAST BRANCH #1</p> <p>EUROFAST TRUNK</p> <p>PICOFAST BRANCH #2</p>	<table border="1"> <tr><td>CONTACT CARRIER MATERIAL/COLOR</td><td>NYLON OR TPU/BLACK</td></tr> <tr><td>MOLDED HEAD MATERIAL/COLOR</td><td>TPU/YELLOW</td></tr> <tr><td>CONTACT MATERIAL/PLATING</td><td>BRASS/GOLD</td></tr> <tr><td>COUPLING NUT MATERIAL/PLATING</td><td>BRASS/NICKEL</td></tr> <tr><td>RATED CURRENT [A]</td><td>4.0 A</td></tr> <tr><td>RATED VOLTAGE [V]</td><td>60 VAC/75 VDC</td></tr> <tr><td>TEMPERATURE RANGE</td><td>-40°C to +105°C (-40°F to +221°F)</td></tr> <tr><td>PROTECTION CLASS</td><td>MEETS NEMA 1,3,4,6P AND IEC IP67</td></tr> </table>	CONTACT CARRIER MATERIAL/COLOR	NYLON OR TPU/BLACK	MOLDED HEAD MATERIAL/COLOR	TPU/YELLOW	CONTACT MATERIAL/PLATING	BRASS/GOLD	COUPLING NUT MATERIAL/PLATING	BRASS/NICKEL	RATED CURRENT [A]	4.0 A	RATED VOLTAGE [V]	60 VAC/75 VDC	TEMPERATURE RANGE	-40°C to +105°C (-40°F to +221°F)	PROTECTION CLASS	MEETS NEMA 1,3,4,6P AND IEC IP67	
CONTACT CARRIER MATERIAL/COLOR	NYLON OR TPU/BLACK																			
MOLDED HEAD MATERIAL/COLOR	TPU/YELLOW																			
CONTACT MATERIAL/PLATING	BRASS/GOLD																			
COUPLING NUT MATERIAL/PLATING	BRASS/NICKEL																			
RATED CURRENT [A]	4.0 A																			
RATED VOLTAGE [V]	60 VAC/75 VDC																			
TEMPERATURE RANGE	-40°C to +105°C (-40°F to +221°F)																			
PROTECTION CLASS	MEETS NEMA 1,3,4,6P AND IEC IP67																			
																				

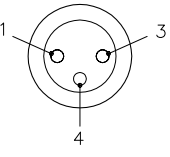
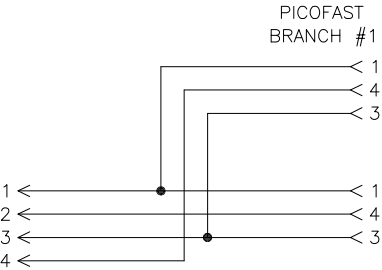
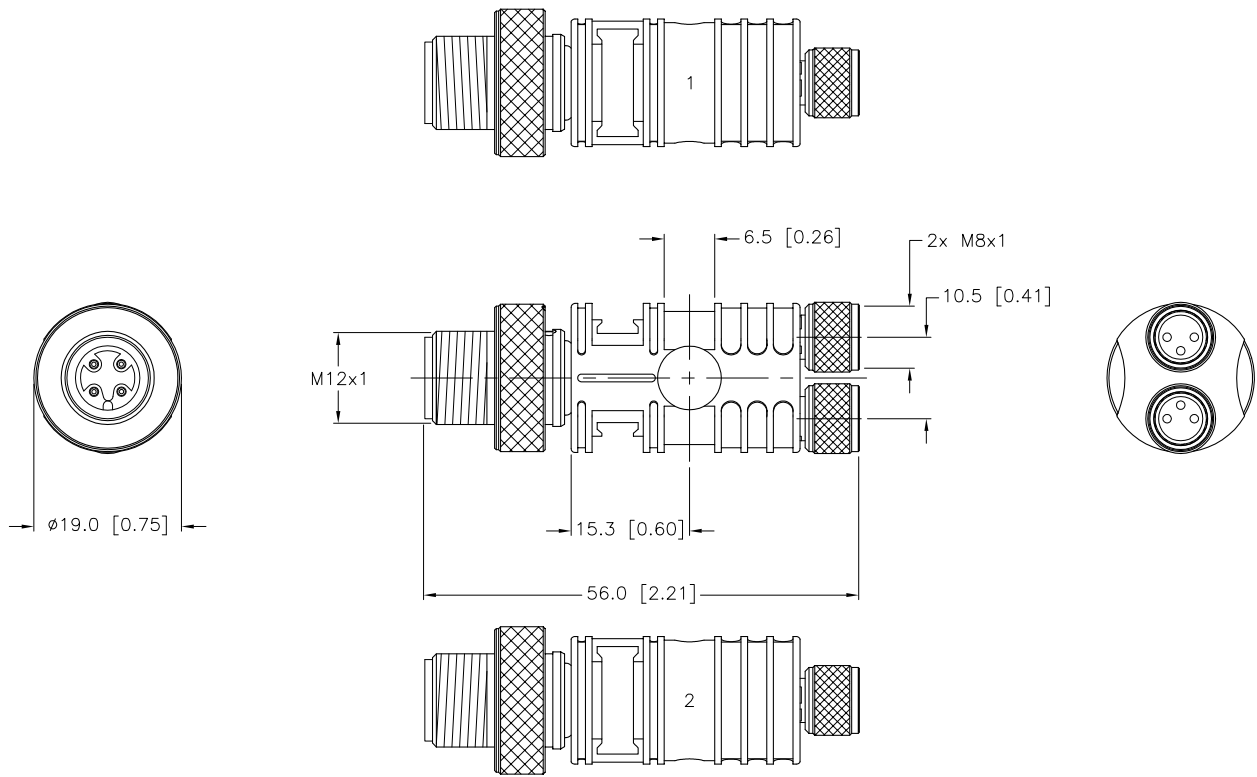
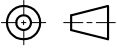

SOURCE DRAWING - FOR REFERENCE ONLY

RELATED DOCUMENTS 1. 2. 3. 4.	3RD ANGLE PROJECTION 	THIS DRAWING IS PROPERTY OF TURCK INC. USE OF THIS DOCUMENT WITHOUT WRITTEN PERMISSION IS PROHIBITED.	<div style="display: flex; justify-content: space-between;"> <div data-bbox="1480 1307 1858 1372"> <b>TURCK INC</b>  <i>High Technology Sensors and Automation Controls</i> </div> <div data-bbox="1869 1291 2068 1404">           3000 CAMPUS DRIVE            MINNEAPOLIS, MN 55441            1-800-544-7769            (763) 553-7300            (763) 553-0708 fax            turck.com         </div> </div>		
MATERIAL  SEE SPECIFICATIONS	ALL DIMENSIONS DISPLAYED ON THIS DRAWING ARE FOR REFERENCE ONLY	DRFT IK DSGN	DATE 06/10/98 SCALE 1=1.0	DESCRIPTION VBRS 4.4-2SKM 3	
FINISH  SEE SPECIFICATIONS	CONTACT TURCK FOR MORE INFORMATION	UNIT OF MEASUREMENT <b>MILLIMETER [ INCH ]</b>		IDENTIFICATION NO. U0117-1	REV E
E DRAWING PROCESSED AS PART OF ECO 33971	CBM 04/07/11 33971	DO NOT SCALE THIS DRAWING			
REV DESCRIPTION	BY DATE ECO NO.	FILE: U0117-1	SHEET 1 OF 1		