

# **TURCK**

## TABLE OF CONTENTS

**A-Intro**

---

---

**B - In-Cabinet Modular**

---

---

**C - In-Cabinet Block**

---

---

**D - On-Machine Modular**

---

---

**E - On-Machine Block**

---

---

**F - Identification (RFID)**

---

---

**G - Accessories**

---

---

**H - Network Wiring**

---

---

**J - Appendix: Network Overview Guides**

---

---

**K - Index**

# TURCK

## DISTRIBUTED I/O

# SALES GUIDE

## INTRODUCTION

The TURCK Distributed I/O Sales Guide endeavors to provide a high level overview of TURCK's Distributed I/O, RFID and network accessories & wiring products. You will find thousands of products to suit our customers' needs including on-machine, in-cabinet, modular and block I/O offerings. In an effort to make this guide easy to use some of TURCK's mature products have been omitted for brevity. Additionally, due to an ever changing market and TURCK's commitment to provide the most technologically advanced solutions for our customers it is possible that new products may exist that have not been incorporated into this printing. So please, if you do not find what you are looking for, consult one of our many other helpful resources, including our distributors, representatives, public website ([www.turck.us](http://www.turck.us)), or our Application Support Hotline (1-800-544-7769).

As mentioned, this guide is meant to provide a high level overview of Turck's Distributed I/O products, giving our customers a solid foundation from which to build on. A review of the table of contents will direct you to the first level of product grouping (i.e. In-Cabinet Modular I/O, On-Machine Block I/O, RFID, etc.). From there each section begins with a brief overview of the product grouping complete with part number keys. Within the sections you will find part selection tables complete with high level product specifications, housing overview and part numbers. Given the dynamic nature of our Distributed I/O product line, individual specifications can change faster than a print guide, therefore the latest detailed product specifications and system design constraints are reserved for information contained on our public website, [www.turck.us](http://www.turck.us).

TURCK provides a complete line of distributed I/O products for every fieldbus protocol including modular and block I/O systems, in-cabinet and on-machine I/O, decentralized intelligence with programmable systems conforming to IEC 61131, or innovative technologies, like RFID.

TURCK's distributed I/O products provide a variety of configurations to suit individual application needs. All platforms provide the ability to reduce time and costs during a project's planning, installation, commissioning, and operation phases.

TURCK's modular I/O systems, such as the **BL20** and **BL67**, provide a high degree of flexibility to varying types of applications. **BL20** terminal-wired, in-cabinet I/O systems include flexible gateway options in a variety of fieldbus protocols, decentralized control/programmability via CoDeSys, an IEC 61131-3 programming software and the ability to integrate motor starters. **BL67** combines all of the flexibility of an in-the-cabinet I/O system with modularity, ruggedness, and connectorization. Both **BL** families support TURCK's **BL ident**® RFID system.

TURCK's block I/O solutions include the **BL compact** and rugged **Advanced I/O module (AIM)** stations. These distributed I/O stations are capable of providing a wide variety of I/O signals, such as digital/discrete, analog, temperature, counter, RS485, RS232, and SSI inputs, as well as RFID capabilities, in a wide range of network protocols.

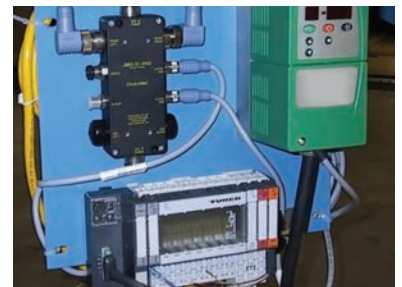
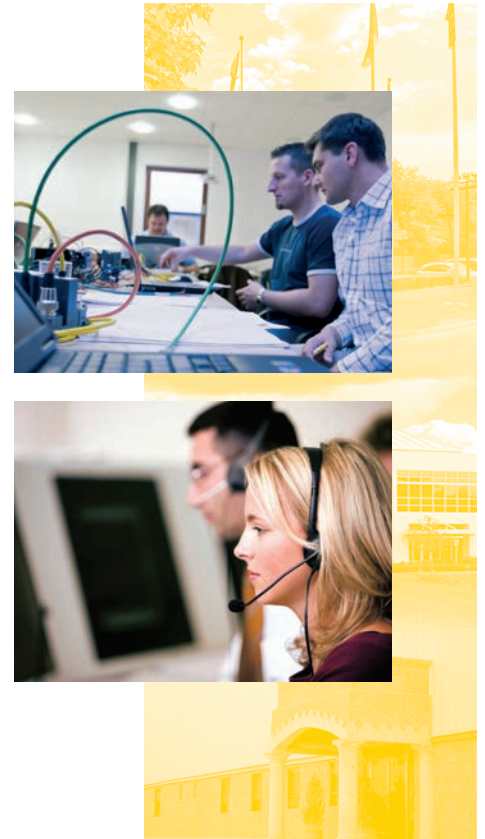

# INNOVATIVE MANUFACTURING CAPABILITIES

The array of applications where TURCK products are used is as extensive as the markets where they are applied.

## DISTRIBUTED CONTROL

TURCK products can be programmed with CoDeSys software to create independent distributed control architectures using gateways with integrated subnet capabilities.

## ETHERNET

TURCK's products offer Ethernet solutions where I/O connects directly or indirectly to Ethernet. Indirect Ethernet gives you the ability to expand the amount of I/O per station with subnet capabilities. TURCK's subnet is self-configuring and offers a seamless transition to the Ethernet layer because the I/O process data is presented as standard Ethernet I/O. TURCK also offers a variety of Ethernet topology options including line topology made possible by Ethernet switches built into our Ethernet products. TURCK also offers innovative solutions that conform to the Common Industrial Protocol (CIP) standards for Quick-Connect.

## RFID - BL ident

RFID solutions for ISO 15693 – HF 13.56 Mhz and EPC Global Gen2 900 Mhz. We have block and modular I/O solutions available for IP20, IP67 and IP68/69K. **BL ident** is available for all of the popular networks including Ethernet, PROFIBUS®, DeviceNet™ and CANopen. We offer standalone control with programmable gateways and the ability to read or write multiple RFID channels available in a single solution. We also offer the ability to integrate RFID with other types of inputs and outputs.

## HARSH ENVIRONMENTS

TURCK products have some of the highest tolerances to environmental extremes on the market. Block I/O products are rated from -40°C to 70°C and are protected up to IP69K. These parts are able to withstand the spraying, cleaning and humid or moist environments often found in food and beverage applications.



# In-Cabinet Modular I/O

In-cabinet (IP20) modular I/O is a cost-efficient networking solution that is used in an enclosure and designed to replace terminal blocks with intelligent I/O. Providing flexible communication capabilities, TURCK in-cabinet modular I/O allows operators to mix and match I/O interfaces and adapters, including digital inputs, digital outputs, analog I/O and RFID. For enhanced performance, in-cabinet modular I/O offers significant space savings with up to 32 I/O on a single card. Modules are ideal for applications with large quantities of I/O, including packaging, conveying and general manufacturing.

## BL20 System

The BL20 system is an IP20 Modular I/O system designed for remotely collecting I/O signals. In comparison to costly and time-consuming historic approaches that brought I/O signals back to a single large cabinet, BL20 uses multiple small cabinets placed near the I/O that they control—providing a flexible, modular solution that saves time and money.

Providing enhanced communication flexibility, the BL20 seamlessly mixes and matches I/O types, communication networks, connection technologies and package styles to meet any project needs.



### Standard BL20 System

- Programmable features for local or distributed control
- Mix and match slices to create the ideal mix of I/O
- System expands to integrate up to 72 slices to meet diverse requirements
- Screw and tension (spring) clamp wiring bases available

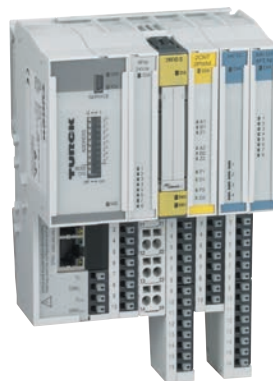

### Economy BL20 System

- Multiprotocol gateway with interface to the higher level control system
- Low-cost gateways provide increased value when connecting to open networks
- Integrated Ethernet switch allows a line topology between multiple gateways without use of an external switch
- Accommodate up to 32 I/O modules
- Designed to work with all TURCK Economy I/O slices, as well as standard BL20 slices
- Economy gateway or slice requires tension (spring) clamp base

**Products****PAGE****BL20 Mechanical Characteristics****B3****Part Number Key****B3****BL20 Gateways****B5****BL20 Digital Slices****B7****BL20 Analog and Specialty Slices****B11****BL20 Bases****B15**

# IN-CABINET MODULAR I/O

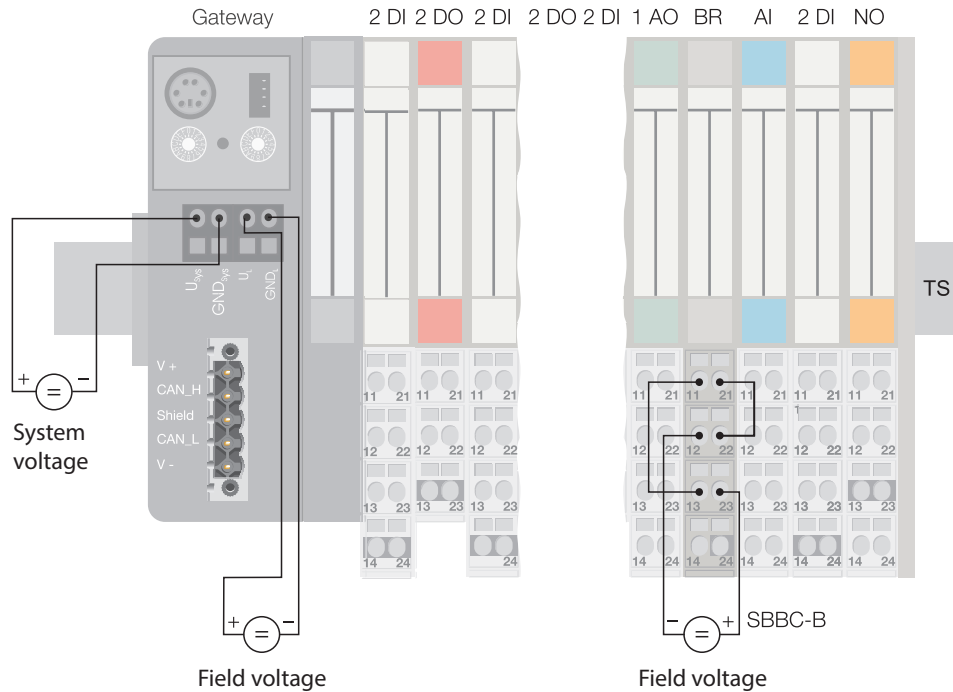

## BL20 Mechanical Overview

- Operating Temperature: 0 to +55°C (32 to 131°F)\*
- Protection: IP20
- Vibration: EN 61131
- Relative Humidity: 5 to 95%, Level RH-2, no condensation
- Shock Test: IEC 68-2-27
- Drop and Topple: IEC 68-2-31 and free full IEC 68-2-32
- Electro-magnetic Compatibility: EN 50 082-2
- Housing Material - Lexan (PC-V0)
- Approvals - CE, UL, CSA, Class 1 Div 2

## BL20 Gateways Part Number Key

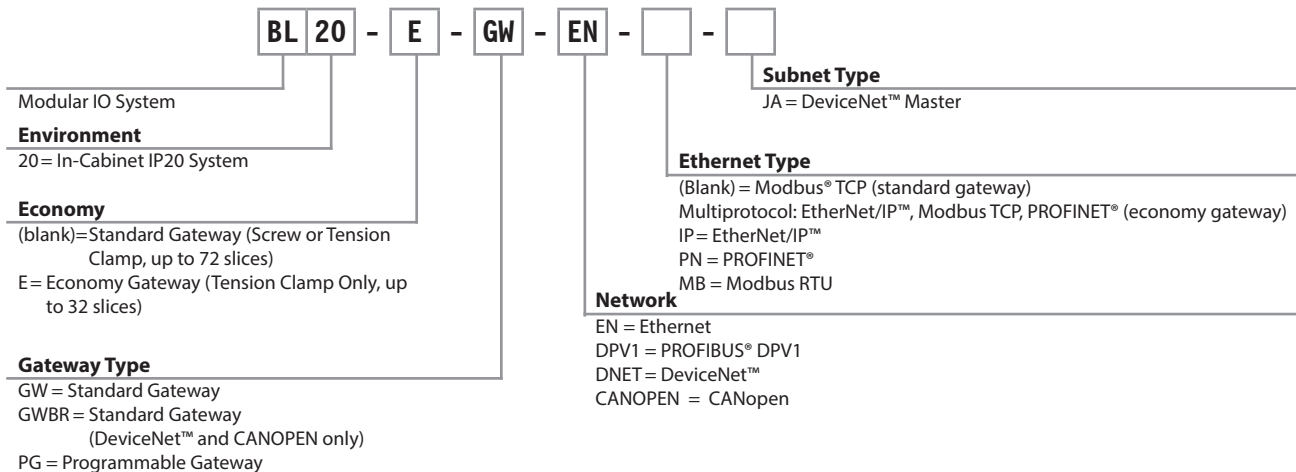

## BL20 Slices Part Number Key

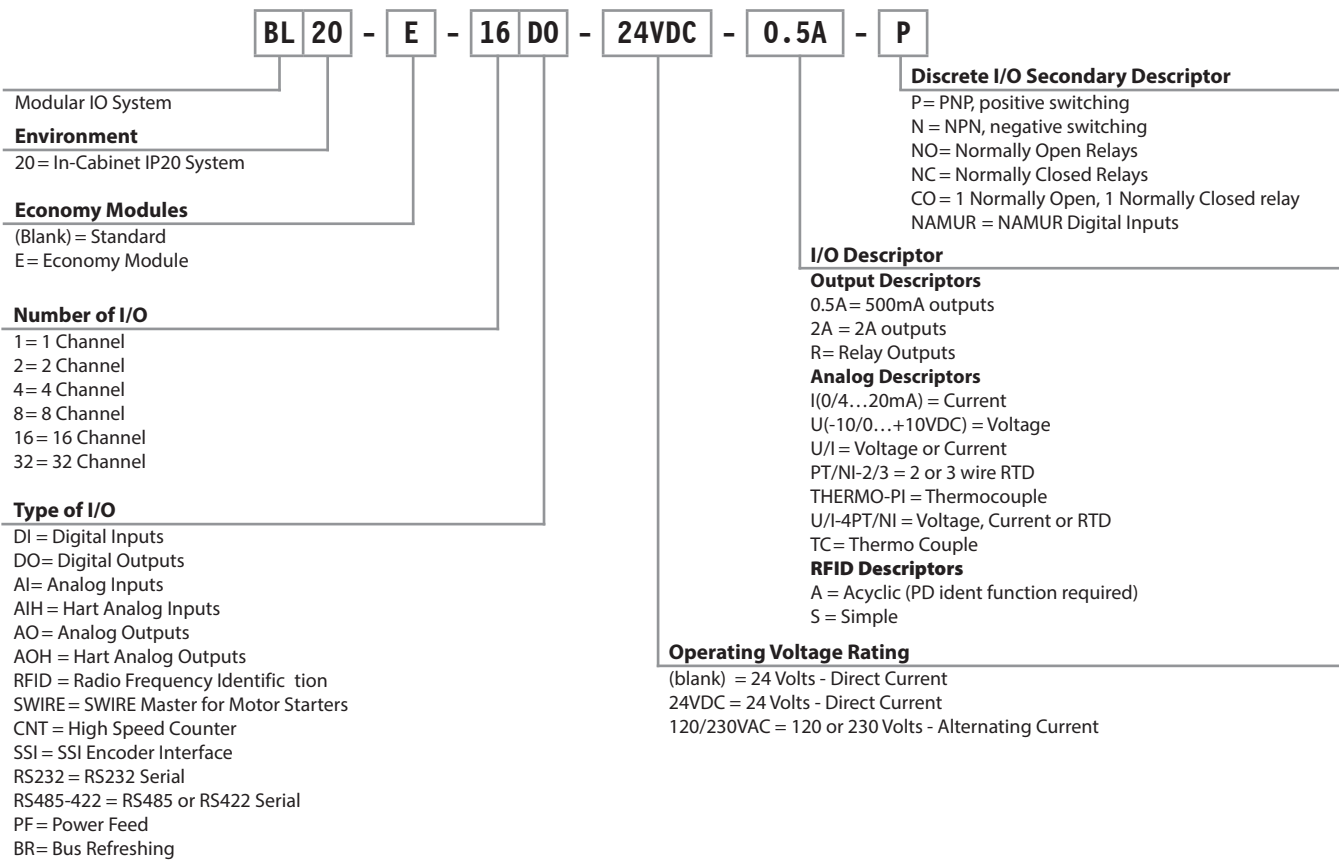

## BL20 Bases Part Number Key

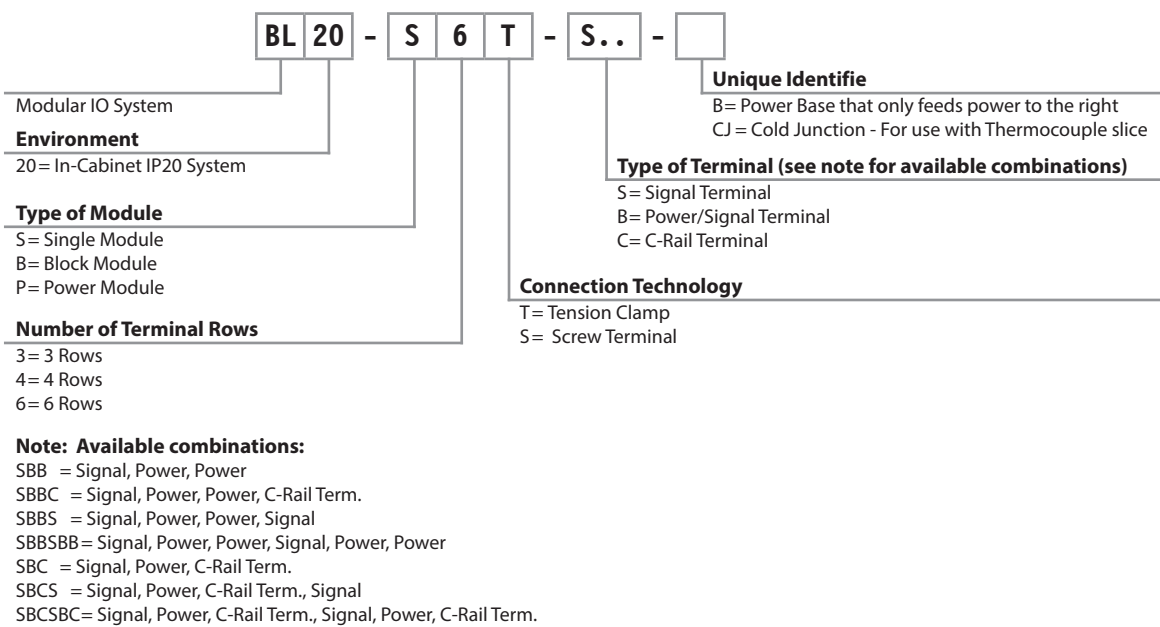

# IN-CABINET MODULAR I/O

## BL20 Gateways

- IP20 Protection
- Suitable for In-Cabinet Applications
- Some Versions Programmable via CoDeSys V2.3
- IEC 61131-3 Programming Structure
- Program in Ladder Logic, Structured Text, or 3 others
- Mix and Match Languages to Suit Application
- Large Library of Pre-written Function Blocks
- Provide Interface between Chosen Network(s) and BL20 I/O
- Up to 72 BL20 Slices can be used with Standard Gateways, 32 with Economy
- Wide Variety of Digital and Analog I/O Available
- Specialty Slices Available inc. RFID, RSXXX, PWM Outputs, and Encoder Inputs



Housing Style		Part Number
	<b>Economy</b>	BL20-E-GW-EN
		BL20-E-GW-EN-PN
	<b>Non-programmable gateways</b>	BL20-E-GW-DP
		BL20-E-GW-DN
		BL20-E-GW-CO
		BL20-E-GW-RS-MB/ET
		BL20-E-GW-EC
		<b>Standard</b>
	BL20-GW-EN	
	BL20-GW-EN-PN	
	BL20-GW-DPV1	
	<b>Programmable gateways</b>	BL20-GWBR-DNET
BL20-GWBR-CANOPEN		
BL20-PG-EN-IP		
		BL20-PG-EN
		BL20-PG-EN-DN-JA

- x standard feature
- + Via CoDeSys FB
- o Optional

# DISTRIBUTED I/O SALES GUIDE



## Physical Characteristics

- Operating Temp 0°C to 55°C
- LED Indication for Quick Diagnostic
- Rotary Switches for ID Settings
- Clear Window

Approvals	Slave Functions								Master Functions				
	EIP	MB TCP/IP	PN	DP	DN	CO	MB RTU	ECAT	MB TCP	PCCC	MB RTU	DN	CO
CE, UL, FM	x	x	x										
CE, UL			x										
CE, UL, FM				x									
CE, UL, FM					x								
CE, UL, FM						x							
CE							x						
CE, UL													x
CE, UL, FM	x												
CE, UL, FM		x											
CE, UL, FM			x										
CE, UL, FM				x									
CE, UL, FM					x								
CE, FM						x							
CE, UL, FM	x								+	+	+		
CE, UL, FM		x							+	+	+		
CE, UL, FM		x							+	+	+	x	o

In-Cabinet Modular

# IN-CABINET MODULAR I/O

## BL20 Digital I/O Slices

- IP20 Protection
- Tension Clamp and Screw Connection Technology
- All I/O Short-circuit Protected
- Standard Slices Include Separated Electronics and Wiring Base
- Economy Slices Include Integrated Electronics and Wiring Base
- PNP and NPN Options
- High Density Economy Slices Create a Small Footprint for Total System
- Powerful 0.5A and 2A Output Drivers Available



Housing Style	Part Number	Number of Inputs	Number of Outputs
	BL20-2DI-24VDC-P	2	
	BL20-2DI-24VDC-N	2	
	BL20-4DI-24VDC-P	4	
	BL20-4DI-24VDC-N	4	
	BL20-4DI-NAMUR	4	
	BL20-16DI-24VDC-P	16	
	BL20-32DI-24VDC-P	32	
	BL20-2DI-120/230VAC-P	2	
	BL20-2DO-24VDC-0.5A-P		2
	BL20-2DO-24VDC-0.5A-N		2
	BL20-2DO-24VDC-2A-P		2
	BL20-4DO-24VDC-0.5A-P		4
	BL20-16DO-24VDC-0.5A-P		16
	BL20-32DO-24VDC-0.5A-P		32
	BL20-2DO-R-CO		2
	BL20-2DO-R-NC		2
	BL20-2DO-R-NO		2
	BL20-2DO-120/230VAC-0.5A		2

			Base Module												
Type of I/O	Power of Outputs	Approvals	BL20-S3*-SBB	BL20-S4*-SBBC	BL20-S4*-SBBS	BL20-S6*-SBBSBB	Integrated	BL20-B3*-SBB	BL20-B4*-SBBC	BL20-B6*-SBBSBB	BL20-S3*-SBC	BL20-S4*-SBCS	BL20-S6*-SBCSBC	BL20-B3*-SBC	BL20-B6*-SBCSBC
PNP		CE, UL, FM	x	x											
NPN		CE, UL, FM	x	x											
PNP		CE, UL, FM			x	x									
NPN		CE, UL, FM			x	x									
NAMUR		CE, UL, FM			x										
PNP		CE, UL, FM						x	x						
PNP		CE, UL, FM								x					
AC		CE, UL	x	x											
PNP	0.5A	CE, UL, FM									x	x			
NPN	0.5A	CE, UL, FM									x	x			
PNP	2A	CE, UL, FM									x	x			
PNP	0.5A	CE, UL, FM										x	x		
PNP	0.5A	CE, UL, FM												x	
PNP	0.5A	CE, UL, FM													x
Relay		CE, UL, FM			x										
Relay		CE, UL, FM			x							x			
Relay		CE, UL, FM			x							x			
AC	0.5A	CE, UL									x	x			

# IN-CABINET MODULAR I/O

## BL20 Digital I/O Slices

- IP20 Protection
- Tension Clamp and Screw Connection Technology
- All I/O Short-circuit Protected
- Standard Slices Include Separated Electronics and Wiring Base
- Economy Slices Include Integrated Electronics and Wiring Base
- PNP and NPN Options
- High Density Economy Slices Create a Small Footprint for Total System
- Powerful 0.5A and 2A Output Drivers Available

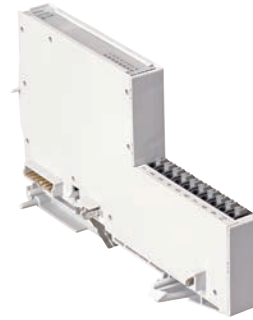

Housing Style	Part Number	Number of Inputs	Number of Outputs
	Inputs BL20-E-8DI-24VDC-P	8	
	Outputs BL20-E-8DO-24VDC-0.5A-P		8
	Inputs BL20-E-16DI-24VDC-P	16	
	Outputs BL20-E-16DO-24VDC-0.5A-P		16

# DISTRIBUTED I/O SALES GUIDE



In-Cabinet Modular

			Base Modules												
Type of I/O	Power of Outputs	Approvals	BL20-S3*-SBB	BL20-S4*-SBBC	BL20-S4*-SBBS	BL20-S6*-SBBSBB	Integrated	BL20-B3*-SBB	BL20-B4*-SBBC	BL20-B6*-SBBSBB	BL20-S3*-SBC	BL20-S4*-SBCS	BL20-S6*-SBCSBC	BL20-B3*-SBC	BL20-B6*-SBCSBC
PNP		CE, UL, FM					x								
PNP	0.5A	CE, UL, FM					x								
PNP		CE, UL, FM					x								
PNP	0.5A	CE, UL, FM					x								

# IN-CABINET MODULAR I/O

## BL20 Analog & Specialty I/O

- IP20 Protection
- RFID Options
- Types of Communication: RS232, RS422, RS485
- Specialty Motor Starter (up to 16 Direct-on-line starter)
- High Speed Counter for Encoders
- SSI Communication for Position Elements (encoder or linear)
- Power Feed Modules to Ensure Proper Supply
- Bus Refreshing Modules to Ensure Proper Communication



Housing Style		Part Number	Number of Inputs	Number of Outputs
	<p>* PG gateway is recommended ** Use only with PG gateway</p>	BL20-1AI-I (0/4...20mA)	1	
		BL20-1AI-U (-10/0...+10VDC)	1	
		BL20-1CNT	1	
		BL20-1SSI	1	
		BL20-1RS232*	1	
		BL20-1RS485/422*	1	
		BL20-PF-24VDC-D	1	
		BL20-PF-120/230VAC-D	1	
		BL20-BR-24VDC-D	1	
		BL20-2AI-I (0/4...20mA)	2	
		BL20-2AI-U (-10/0...+10VDC)	2	
		BL20-2AIH-I	2	
		BL20-2AI-THERMO-PI	2	
		BL20-2AI-PT/NI-2/3	2	
		BL20-2RFID-S	2	
		BL20-2RFID-A**	2	
		BL20-4AI-U/I	4	
		BL20-1AO-I (0/4...20mA)		1
		BL20-2AO-I (0/4...20mA)		2
		BL20-2AO-U (-10/0...+10VDC)		2
		BL20-2AOH-I		2

# DISTRIBUTED I/O SALES GUIDE



In-Cabinet Modular

0/4-20 mA Input	-10/0-10 V Input	0/4-20 mA Input (HART)	Thermocouple	RTD Input	0/4-20 Output	-10/0-10 V Output	0/4-20 mA (HART)	RFID	Counter	Counter/PWM	SSI	RS232	RS485/RS422	Motor Starter	Power Feed	Bus Refreshing	BL20-S3*-SBB	BL20-P3*-SBB	BL20-S4*-SBBS	BL20-S4*-SBBS-CJ	BL20-P4*-SBBC	BL20-S6*-SBCSBC	Integrated	BL20-P3*-SBB-B	Approvals
x																	x		x						CE, UL
	x																x		x						CE, UL, FM
									x										x						CE, UL, FM
											x								x						CE, UL, FM
												x							x						CE, UL, FM
													x						x						CE, UL, FM
															x			x				x			CE, UL
																x		x				x			CE, UL, FM
x																	x		x						CE, UL, FM
	x																x		x						CE, UL, FM
		x																	x						CE, UL, FM
			x																	x					CE, UL, FM
				x													x		x						CE, UL, FM
									x										x						CE, UL, FM
																									CE, UL, FM
x	x																						x		CE, UL, FM
					x												x								CE, UL
					x												x								CE, UL, FM
						x											x								CE, UL, FM
							x												x						CE, UL, FM

# IN-CABINET MODULAR I/O

## BL20 Analog & Specialty I/O

- IP20 Protection
- RFID Options
- Types of Communication: RS232, RS422, RS485
- Specialty Motor Starter (up to 16 Direct-on-line starter)
- High Speed Counter for Encoders
- SSI Communication for Position Elements (encoder or linear)
- Power Feed Modules to Ensure Proper Supply
- Bus Refreshing Modules to Ensure Proper Communication

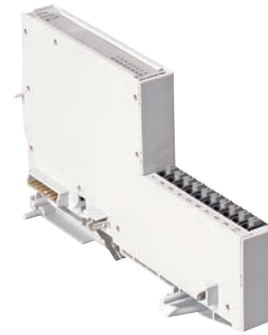

Housing Style		Part Number	Number of Inputs	Number of Outputs
	Inputs	BL20-E-8AI-U/I-4PT/NI	8	
		BL20-E-4AI-TC	4	
		BL20-E-1SWIRE	1	
	Outputs	BL20-E-4AO-U/I		4
	Inputs & Outputs	BL20-E-2CNT-2PWM*	2	2

# DISTRIBUTED I/O SALES GUIDE



0/4-20 mA Input	-10/0-10 V Input	0/4-20 mA Input (HART)	Thermocouple	RTD Input	0/4-20 Output	-10/0-10 V Output	0/4-20 mA (HART)	RFID	Counter	Counter/PWM	SSI	RS232	RS485/RS422	Motor Starter	Power Feed	Bus Refreshing	BL20-S3*-SBB	BL20-P3*-SBB	BL20-S4*-SBBS	BL20-S4*-SBBS-CJ	BL20-P4*-SBBC	BL20-S6*-SBCSBC	Integrated	BL20-P3*-SBB-B	Approvals
x	x			x																			x		CE, UL, FM
			x																				x		CE
														x									x		UL
					x	x																	x		CE, UL, FM
										x													x		UL

In-Cabinet Modular

# IN-CABINET MODULAR I/O

## BL20 Wiring Bases



Housing Style	BL20 Wiring Bases
<p>4.630 [117.6] REF</p> <p>.496 [12.6] REF</p> <p>1.717 [43.6] REF</p>	<ul style="list-style-type: none"> <li>BL20-S3S-SBB</li> <li>BL20-S3S-SBC</li> <li>BL20-S3T-SBB</li> <li>BL20-S3T-SBC</li> <li>BL20-P3S-SBB</li> <li>BL20-P3S-SBB-B</li> <li>BL20-P3T-SBB</li> <li>BL20-P3T-SBB-B</li> </ul>
<p>5.075 [128.9] REF</p> <p>.496 [12.6] REF</p> <p>1.717 [43.6] REF</p>	<ul style="list-style-type: none"> <li>BL20-S4S-SBBC</li> <li>BL20-S4S-SBBS</li> <li>BL20-S4S-SBBS-CJ</li> <li>BL20-S4S-SBCS</li> <li>BL20-S4T-SBBC</li> <li>BL20-S4T-SBBS</li> <li>BL20-S4T-SBBS-CJ</li> <li>BL20-S4T-SBCS</li> <li>BL20-P4S-SBBC</li> <li>BL20-P4S-SBBC-B</li> <li>BL20-P4T-SBBC</li> <li>BL20-P4T-SBBC-B</li> </ul>
<p>6.083 [154.5] REF</p> <p>.496 [12.6] REF</p> <p>1.717 [43.6] REF</p>	<ul style="list-style-type: none"> <li>BL20-S6S-SBBSBB</li> <li>BL20-S6S-SBCSBC</li> <li>BL20-S6T-SBBSBB</li> <li>BL20-S6T-SBCSBC</li> </ul>

Housing Style	BL20 Wiring Bases
	<ul style="list-style-type: none"> <li>BL20-B3S-SBB</li> <li>BL20-B3S-SBC</li> <li>BL20-B3T-SBB</li> <li>BL20-B3T-SBC</li> </ul>
	<ul style="list-style-type: none"> <li>BL20-B4S-SBBC</li> <li>BL20-B4T-SBBC</li> </ul>
	<ul style="list-style-type: none"> <li>BL20-B6S-SBBSBB</li> <li>BL20-B6S-SBCSBC</li> <li>BL20-B6T-SBBSBB</li> <li>BL20-B6T-SBCSBC</li> </ul>

# excom<sup>®</sup> Remote I/O System

The excom<sup>®</sup> remote I/O system is ideal for use in hazardous or non-hazardous locations. The system provides bus-compatible, decentralized input and output connection modules with a protection rating of IP20 for connection of binary and analog intrinsically safe field devices. Explosion protection enables use in zones 1 and 2.

## excom System

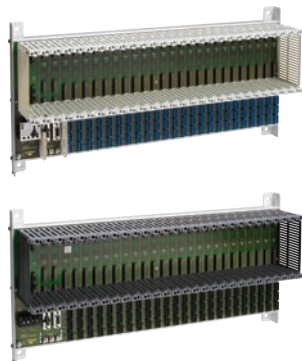

The excom system is available in four mounting configurations for application flexibility:

- Standard MT18, when used with segment coupler, mounts in zone 1 (Class 1, Division 2) areas with up to 16 intrinsically safe I/O module connections to field devices in zone 0 (Class 1, Division 1) areas
- MT24, when used with segment coupler, mounts in zone 2 (Class 1, Division 2) areas with up to 24 intrinsically safe I/O module connections to field devices in zone 0 (Class 1, Division 1) areas
- MT24 mounts in non-hazardous areas with up to 24 intrinsically safe I/O module connections to field devices in zone 0 (Class 1, Division 1) areas
- MT24 mounts in non-hazardous areas with up to 24 non-intrinsically safe I/O module connections to field devices in non-hazardous areas



## excom Features

- Redundant power supplies and gateways
- Intrinsically safe connection to PROFIBUS-DP with V1 functionality
- Online programming and configuration of all parameters
- Consistent HART parameterization from the process control system to the field device
- Exchange and extension of all components during operation



## PRODUCTS

## PAGE

Typical System Layout

B17

Zone 1, excom - Remote I/O for Class I Div 2 Installation

B21

Zone 2, excom - Remote I/O for Hazardous Class I Div 2 Areas

B25

excom - Remote I/O for Non-Ex Areas with Ex hardware

B29

excom - Remote I/O for Non-Ex Areas with Non-Ex hardware

B33

excom - Accessories for Ex and Non-Ex Areas

B37

# IN-CABINET MODULAR I/O

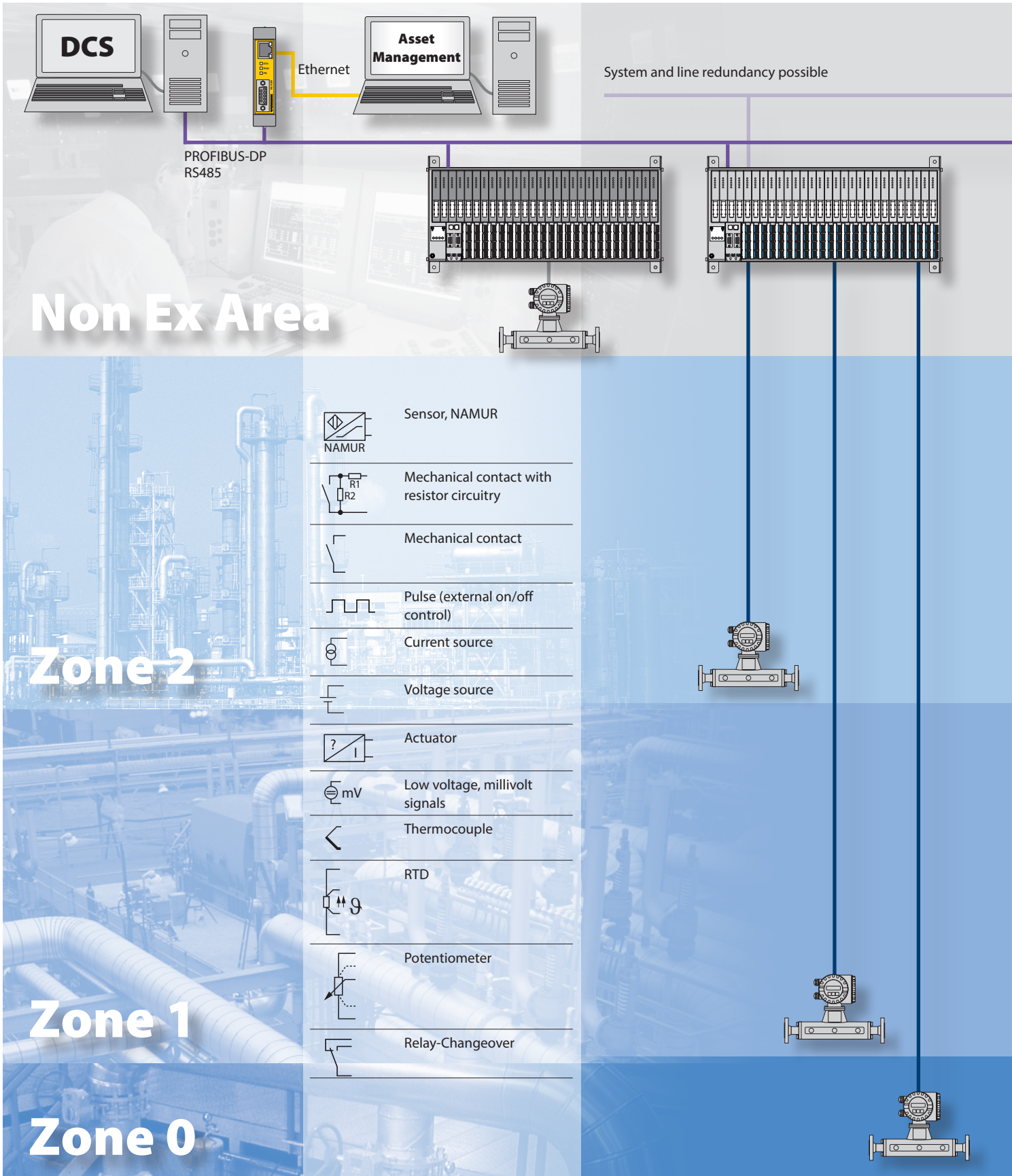

# DISTRIBUTED I/O SALES GUIDE

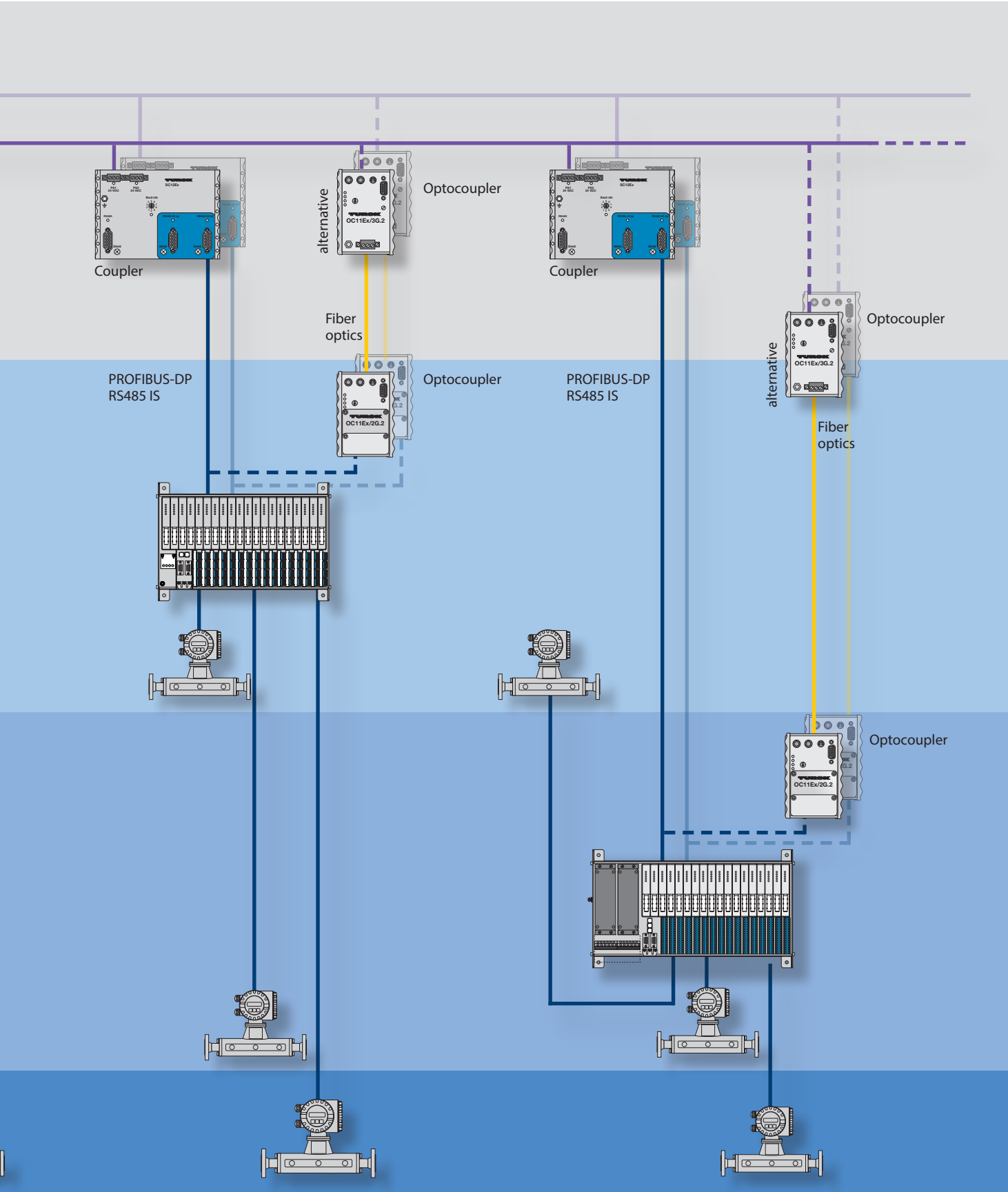

In-Cabinet Modular

# IN-CABINET MODULAR I/O

## Zone 1, excom® - Remote I/O for Class I Div 2 Installation\*

- Up to 16 Intrinsically Safe I/O Module Connections to 128 Field Devices in Zone 0 (Class 1, Division 1) Areas



### Module Rack

Housing Style	Part number
<p>10.236 [260.0] REF 9.252 [235.0] Ø.276 [Ø7.0] 4x 16.220 [412.0] 17.323 [440.0] REF 5.059 [128.5] REF</p>	MT18-R024
	MT18-C024
	MT18-C230

### I/O Cards

Housing Style	Part Number	Number of Channels
	<b>Input Cards</b>	
	DI401EX	4-channel discrete
	AI401EX	4-channel analog
	AI41EX	4-channel analog
	AI43EX	4-channel analog
	AIH40EX	4-channel analog
	AIH41EX	4-channel analog
	TI40EX	4-channel temperature
	<b>Output Cards</b>	
	D040EX	4-channel discrete
	D0401EX	4-channel discrete
	A040EX	4-channel analog
	<b>Input/Output Cards</b>	
	DM80EX	8-channel
DF20EX	2-channel frequency	

Number of I/O modules	Connection type	Power supply	Approvals
16	Screw terminals	DC	FM (US/Canada)
16	Spring terminals	DC	
16	Spring terminals	AC	

Input/Output Type	Ambient Temp. (°C)	Approvals
NAMUR or dry contact	-20...+70	PTB 10 ATEX 2024
active/passive	-20...+60	FM (US/Canada)
passive	-20...+60	
potentiometer	-20...+60	
active/passive HART	-20...+60	FM (US/Canada)
passive HART	-20...+60	FM (US/Canada)
RTD, TC	-20...+70	FM (US/Canada)
IS actuators	-20...+60	FM (US/Canada), PTB 01 ATEX 2047
IS actuators	-20...+70	FM (US/Canada), PTB 10 ATEX 2024, CE
		FM (US/Canada)
NAMUR or dry contact	-20...+70	FM (US/Canada), PTB 00 ATEX 2178
NAMUR or dry contact	-20...+60	FM (US/Canada), PTB 00 ATEX 2178

# IN-CABINET MODULAR I/O

## Zone 1, excom® - Remote I/O for Class I Div 2 Installation

- In Order to Assemble a System, the Following are Required:
  - 1xMT18
  - 1xPSD24EX
  - 1xGDP-IS
  - 1xSC12EX



### Gateway Card

Housing Style	Part Number	Fieldbus
	GDP-IS/FW2.1	PROFIBUS®-DP

### Power Supply

Housing Style	Part number	Power supply type
	PSD24EX	24VDC
	PPSA115EX	115VAC

# DISTRIBUTED I/O SALES GUIDE



In-Cabinet Modular

Transfer Rate	Ambient Temperature (°C)	Approvals
9.6kBit/s...1.5MBit/s	-20...+70	PTB 09 ATEX 2013, CE, FM (US/Canada)

Approvals
FM (US/Canada)

# IN-CABINET MODULAR I/O

## Zone 2, excom® - Remote I/O for Hazardous Class I Div 2 Areas\*

- Up to 24 Intrinsically Safe I/O Module Connections to 192 Field Devices in Zone 0 (Class 1, Division 1) Areas

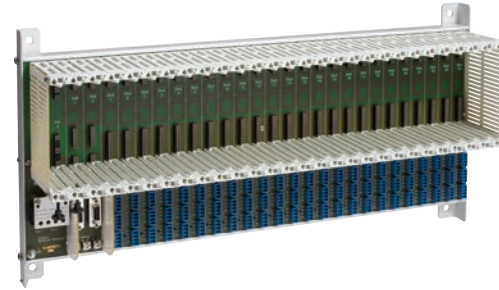

### Module Rack

Housing Style	Part number
<p>10.236 [260.0] REF</p> <p>9.252 [235.0]</p> <p>Ø.276 [Ø7.0] 4x</p> <p>L1</p> <p>L2</p> <p>5.059 [128.5] REF</p> <p>MT16: L1=352 mm L2=380 mm</p> <p>MT24: L1=498 mm L2=526 mm</p> <p>* Requires use of SC12EX segment coupler</p>	<p>MT16-3G</p> <p>MT24-3G</p>

### I/O Cards

Housing Style	Part Number	Number of Channels
<p>4.646 [118.0] REF</p> <p>709 [18.0] REF</p> <p>4.173 [106.0] REF</p>	<b>Input Cards</b>	
	DI401EX	4-channel discrete
	AI401EX	4-channel analog
	AI41EX	4-channel analog
	AI43EX	4-channel analog
	AIH40EX	4-channel analog
	AIH41EX	4-channel analog
	TI40EX	4-channel temperature
	<b>Output Cards</b>	
	D040EX	4-channel discrete
	D0401EX	4-channel discrete
	A040EX	4-channel analog
	<b>Input/Output Cards</b>	
	DM80EX	8-channel
DF20EX	2-channel frequency	

Number of I/O modules	Connection type	Power supply
16	Screw terminals	DC
24	Screw terminals	DC

Input/Output Type	Ambient Temp. (°C)	Approvals
NAMUR or dry contact	-20...+70	PTB 10 ATEX 2024
active/passive	-20...+60	FM (US/Canada)
passive	-20...+60	
potentiometer	-20...+60	
active/passive HART	-20...+60	FM (US/Canada)
passive HART	-20...+60	FM (US/Canada)
RTD, TC	-20...+70	FM (US/Canada)
IS actuators	-20...+60	FM (US/Canada), PTB 01 ATEX 2047
IS actuators	-20...+70	FM (US/Canada), PTB 10 ATEX 2024, CE
		FM (US/Canada)
NAMUR or dry contact	-20...+70	FM (US/Canada), PTB 00 ATEX 2178
NAMUR or dry contact	-20...+60	FM (US/Canada), PTB 00 ATEX 2178

# IN-CABINET MODULAR I/O

## Zone 2, excom<sup>®</sup> - Remote I/O for Class I Div 2 Installation

- In Order to Assemble a System, the Following are Required:
  - 1xMT16-3G or MT24-3G
  - 1xPSM24-3G
  - 1xGDP-IS
  - 1xSC12EX



### Gateway Card

Housing Style	Part Number	Fieldbus
	GDP-IS/FW2.1	PROFIBUS <sup>®</sup> -DP

### Power Supply Card

Housing Style	Part number	Power supply type
	PSM24-3G	24VDC

# DISTRIBUTED I/O SALES GUIDE



In-Cabinet Modular

Transfer Rate	Ambient Temperature (°C)	Approvals
9.6kBit/s...1.5MBit/s	-20...+70	PTB 09 ATEX 2013, CE, FM (US/Canada)

Approvals
FM* * Pending

# IN-CABINET MODULAR I/O

## excom® - Remote I/O for Non-Ex Areas with Ex hardware

- Up to 24 Intrinsically Safe I/O Module Connections to 192 Field Devices in Zone 0(Class 1, Div. 1) Areas

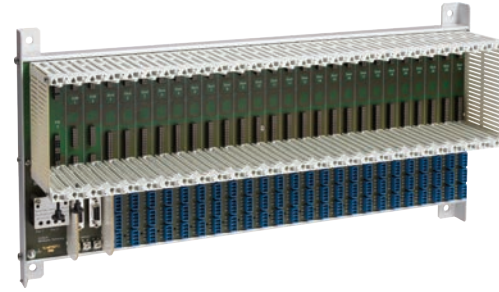

### Module Rack

Housing Style	Part number
<p>10.236 [260.0] REF 9.252 [235.0] Ø.276 [Ø7.0] 4x L1 L2 MT16: L1=352 mm L2=380 mm MT24: L1=498 mm L2=526 mm 5.059 [128.5] REF Does not require SC12EX segment coupler</p>	<b>MT16-G3G</b>  <b>MT24-3G</b>

### I/O Cards

Housing Style	Part Number	Number of Channels
<p>4.646 [118.0] REF .709 [18.0] REF 4.173 [106.0] REF</p>	<b>Input Cards</b>	
	DI401EX	4-channel discrete
	AI401EX	4-channel analog
	AI41EX	4-channel analog
	AI43EX	4-channel analog
	AIH40EX	4-channel analog
	AIH41EX	4-channel analog
	TI40EX	4-channel temperature
	<b>Output Cards</b>	
	D040EX	4-channel discrete
	D0401EX	4-channel discrete
	A040EX	4-channel analog
	<b>Input/Output Cards</b>	
	DM80EX	8-channel
	DF20EX	2-channel frequency

Number of I/O modules	Connection type	Power supply
16	Screw terminals	DC
24	Screw terminals	DC

Input/Output Type	Ambient Temp. (°C)	Approvals
NAMUR or dry contact	-20...+70	PTB 10 ATEX 2024
active/passive	-20...+60	FM (US/Canada)
passive	-20...+60	
potentiometer	-20...+60	
active/passive HART	-20...+60	FM (US/Canada)
passive HART	-20...+60	FM (US/Canada)
RTD, TC	-20...+70	FM (US/Canada)
IS actuators	-20...+60	FM (US/Canada), PTB 01 ATEX 2047
IS actuators	-20...+70	FM (US/Canada), PTB 10 ATEX 2024, CE
		FM (US/Canada)
NAMUR or dry contact	-20...+70	FM (US/Canada), PTB 00 ATEX 2178
NAMUR or dry contact	-20...+60	FM (US/Canada), PTB 00 ATEX 2178

# IN-CABINET MODULAR I/O

## excom® - Remote I/O for Non-Ex Areas with Ex hardware

- In Order to Assemble a System, the Following are Required:
  - 1xMT16-3G or MT24-3G
  - 1xPSM24-3G
  - 1xGDP-NI



### Gateway Card

Housing Style	Part Number	Fieldbus
	GDP-NI / FW...	PROFIBUS®-DP

### Power Supply Card

Housing Style	Part number	Power supply type
	PSM24-3G	24VDC



In-Cabinet Modular

Transfer Rate	Ambient Temperature (°C)	Approvals
9.6kBit/s...1.5MBit/s	-20...+70	

Approvals
FM* * Pending

# IN-CABINET MODULAR I/O

## excom® - Remote I/O for Non-Ex Areas with Non-Ex hardware

- Up to 24 Non-Intrinsically Safe I/O Module Connections to 192 Field Devices in Non-Hazardous Areas



### Module Rack

Housing Style	Part number
<p>*Screw terminals ordered separately</p>	MT24-N

### I/O Cards

Housing Style	Part Number	Number of Channels
	<b>Input Cards</b>	
	AI40-N	4-channel analog
	AIH41-N	4-channel analog
	AI43-N	4-channel analog
	AIH40-N	4-channel analog
	AIH41-N	4-channel analog
	TI40N	4-channel temperature
	<b>Output Cards</b>	
	D040-N	4-channel discrete
	A040-N Cards	4-channel analog
	D060R-N	6-channel mechanical
	<b>Input/Output Cards</b>	
	DM80-N	8-channel
DF20-N	2-channel frequency	

Number of I/O modules	Connection type	Power supply
24	Screw terminals	DC

Input/Output Type	Ambient Temperature (°C)	Approvals
active/passive	-20...+60	
passive	-20...+60	
potentiometer	-20...+60	
active/passive HART	-20...+60	
passive HART	-20...+60	
RTD, TC	-20...+70	
IS actuators	-20...+70	
SPST Relay contacts		
NAMUR or dry contact	-20...+70	
NAMUR or dry contact	-20...+60	

# IN-CABINET MODULAR I/O

## excom® - Remote I/O for Non-Ex Areas with Non-Ex hardware

- In Order to Assemble a System, the Following are Required:
  - 1xMT24-N
  - 1xPSM24-N
  - 1xGDP-N



### Gateway Card

Housing Style	Part Number	Fieldbus
	GDP-N/FW...	PROFIBUS®-DP

### Power Supply Card

Housing Style	Part number	Power supply type
	PSM24-N	24VDC

# DISTRIBUTED I/O SALES GUIDE



In-Cabinet Modular

Transfer Rate	Ambient Temperature (°C)	Approvals
9.6kBit/s...1.5MBit/s	-20...+70	

Approvals

# IN-CABINET MODULAR I/O

## excom® - Accessories for Ex and Non-Ex Areas

- Segment Coupler Allows Mounting in Zone 1 or 2



Housing Style	Part Number	Description/Notes
	SC12-EX	PROFIBUS®-DP to RS485IS interface

Housing Style	Part Number	Description
<p>Preconfigured cable part number: D9T-RS485IS D9T-RS485IS 451B-*M</p>	D9T-RS485IS	Connector for excom MT (backplane) and SC12-EX RS485-IS Connector
<p>Preconfigured cable part number: D9S/T D9S D9S/T 455-*M-*M</p>	D9T-RS485	Connector for SC12-EX PROFIBUS-DP and PB-XEPI2 Connector

\* denotes length in meters

# DISTRIBUTED I/O SALES GUIDE



Number of Nodes	Ambient Temperature (°C)	Approvals
62 (31 with redundancy)	-20...+70	FM (US)

In-Cabinet Modular

# IN-CABINET MODULAR I/O

excom® - Accessories for Ex and Non-Ex Areas

- FDT-DTM Parameterization Via PACTWARE



Housing Style	Part Number	Description	Supply Voltage
	<b>PB-XEPI2</b>	EtherNet to PROFIBUS® interface	24VDC (19.2...28.8VDC)

Housing Style	Part Number	Description
	<b>STB16-4RS/1,5-BU</b>	4-pin terminal block, screw terminals, blue (set of 16)
	<b>STB16-4RS/1,5-BK</b>	4-pin terminal block, screw terminals, black (set of 16)

# DISTRIBUTED I/O SALES GUIDE



In-Cabinet Modular

Current Consumption	Ambient Temperature (°C)	Operating Systems
≤200 mA	0...+50	Windows XP/7

# In-Cabinet Block I/O

In-cabinet (IP20) block I/O is a cost-efficient networking solution that is used in an enclosure and designed to replace terminal blocks with intelligent I/O. TURCK in-cabinet block I/O modules accommodate applications with a wide range of analog, digital and specialty I/O, as well as I/O for safety systems. Modules are also ideal for applications when dealing with large batches of similar I/O signals.



## FEN20 Ethernet digital block I/O

- Features Multiprotocol capability for Modbus® TP, EtherNet/IP™ or PROFINET®
- Freely configurable I/Os
- Two housing sizes to support 8 or 16 channels



## FDP20 PROFIBUS® digital I/O

- Diagnostics according to PROFIBUS standard
- Freely configurable I/Os
- Channel-specific diagnostics
- Up to 16 channels



## FDN20 DeviceNet™ block I/O

- DeviceNet™ or Isolated I/O power supply
- Channel- or module-specific diagnostics
- Three housing sizes to support 8, 16 or 32 channels
- Available with M12 receptacle for easy panel mounting



## FAS20 AS-interface® digital I/O

- Up to 8 channels
- Available with M12 receptacle for easy panel mounting
- V3.0 compatible, 62 modules with 4in/4out each



## PRODUCT

Part Number Key

Discrete I/O

## PAGE

C3

C5

# IN-CABINET BLOCK I/O

## In-Cabinet Block I/O Part Number Key

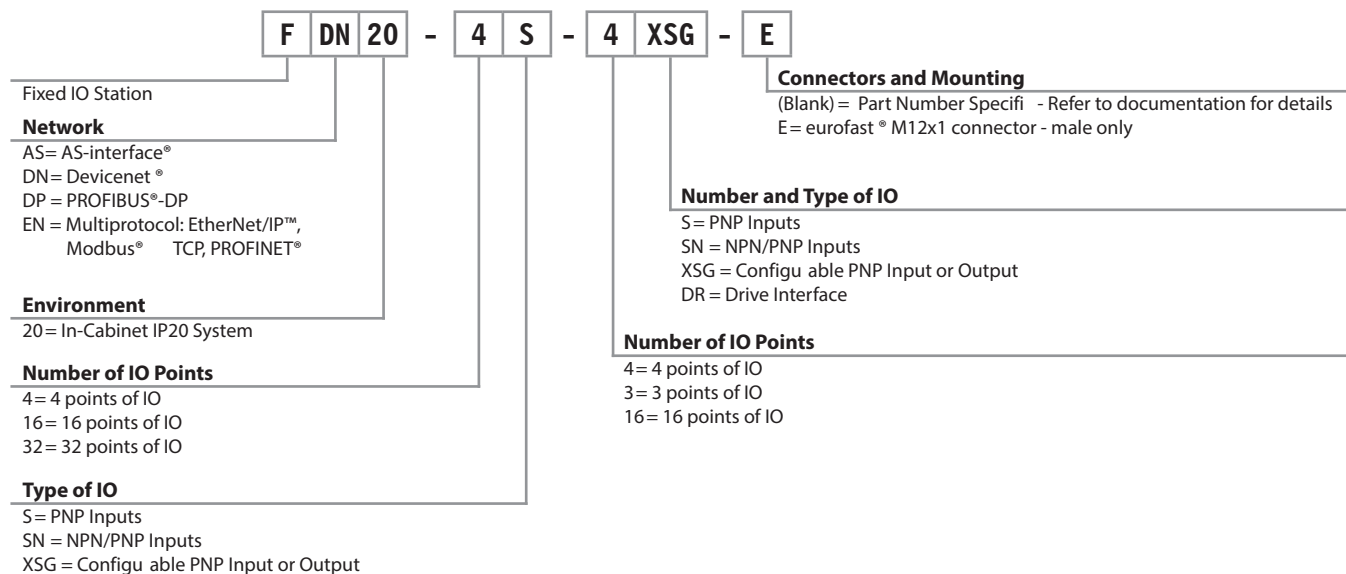



**Notes:**



In-Cabinet Block

# IN-CABINET BLOCK I/O

## Discrete I/O

- PNP Style I/O\*
- 0.5A Outputs\*
- Fiberglass Reinforced Nylon Housing
- Screw Terminals
- IP20

\* Unless otherwise specified in the notes.



Pictures represent a sampling of housings

Housing Style	Part Number	Protocol
	FEN20-4S-4XSG	Multiprotocol
	FAS20-4S	AS-I
	FAS20-4S	AS-I
	FAS20-4S	AS-I
	FAS20-4S-4G	AS-I
	FAS20-4S-4G-A	AS-I
	FDN20-4S-4XSG	DeviceNet™
	FAS20-4S-4G-R-A	AS-I
	FAS20-4S-R	AS-I

# DISTRIBUTED I/O SALES GUIDE



In-Cabinet Block

Number of Inputs	Number of Outputs	Aux. Power	Certifications	Notes:
8	4		CE	4 Configurable Input or Output Channels
4			UL, CE	AS-I v3.0 Extended Addressing
4			UL, CE	AS-I v3.0 Extended Addressing
4			UL, CE	AS-I v3.0 Extended Addressing
4	4		UL, CE	130 mA Combined Outputs, AS-I v2.0/2.1/3.0 Standard Addressing
4	4	x	UL, CE	High Power 1A Outputs, AS-I v3.0 Extended Addressing
8	4		UL, CE, CSA, FM	4 Configurable Input or Output Channels
4	4	x	UL, CE	High Power 1A Outputs, AS-I v3.0 Extended Addressing, Removable Terminals
4			UL, CE	AS-I v3.0 Extended Addressing, Removable Terminals

# IN-CABINET BLOCK I/O

## Discrete I/O

- PNP Style I/O\*
- 0.5A Outputs\*
- Fiberglass Reinforced Nylon Housing
- Screw Terminals
- IP20

\* Unless otherwise specified in the notes.



Pictures represent a sampling of housings

Housing Style	Part Number	Protocol
	FDN20-4S-4XSG/C1261	DeviceNet™
	FAS20-4S-4G-E-A	AS-I
	FAS20-4S-E	AS-I
	FDN20-4S-4XSG-E	DeviceNet

# DISTRIBUTED I/O SALES GUIDE



Number of Inputs	Number of Outputs	Aux. Power	Certifications	Notes:
8	4		UL, CE	4 Configurable Input or Output Channels, Removable Terminals
4	4	x	UL, CE	High Power 1A Outputs, AS-I v3.0 Extended Addressing, M12 Fieldbus Connector
4			UL, CE	AS-I v3.0 Extended Addressing, M12 Fieldbus Connector
8	4		UL, CE, CSA, FM	4 Configurable Input or Output Channels, M12 Fieldbus Connector

In-Cabinet Block

# IN-CABINET BLOCK I/O

## Discrete I/O

- PNP Style I/O\*
- 0.5A Outputs\*
- Fiberglass Reinforced Nylon Housing
- Screw Terminals
- IP20

\* Unless otherwise specified in the notes.



Pictures represent a sampling of housings

Housing Style	Part Number	Protocol
	FAS20-4S-4G-ER-A	AS-I
	FAS20-4S-ER	AS-I
	FDN20-4S-4XSG-E/C1261	DeviceNet™

# DISTRIBUTED I/O SALES GUIDE



Number of Inputs	Number of Outputs	Aux. Power	Certifications	Notes:
4	4	x	UL, CE	High Power 1A Outputs, AS-I v3.0 Extended Addressing, M12 Fieldbus Connector, Removable Terminals
4			UL, CE	AS-I v3.0 Extended Addressing, M12 Fieldbus Connector, Removable Terminals
8	4		UL, CE	4 Configurable Input or Output Channels, M12 Fieldbus Connector, Removable Terminals

In-Cabinet Block

# IN-CABINET BLOCK I/O

## Discrete I/O

- PNP Style I/O\*
- 0.5A Outputs\*
- Fiberglass Reinforced Nylon Housing
- Screw Terminals
- IP20

\* Unless otherwise specified in the notes.



Pictures represent a sampling of housings

Housing Style	Part Number	Protocol
	FEN20-16XSG	Multiprotocol
	FDN20-16S	DeviceNet™
	FDN20-16XSG	DeviceNet
	FDN20-4DR	DeviceNet
	FDN20-4DR	DeviceNet
	FDP20-16S	PROFIBUS-DP
	FDP20-16XSG	PROFIBUS-DP

# DISTRIBUTED I/O SALES GUIDE



Number of Inputs	Number of Outputs	Aux. Power	Certifications	Notes:
16		x	CE	16 Configurable Input or Output Channels
16		x	UL, CE, CSA, FM	
16	16	x	UL, CE, CSA, FM	16 Configurable Input or Output Channels
4	16		UL, CE, CSA	4 NPN Inputs, 12 Solid State Relay Outputs, 4 Analog Voltage Outputs
4	16		UL, CE, CSA	4 NPN Inputs, 12 Solid State Relay Outputs, 4 Analog Voltage Outputs
16		x	UL, CE, CSA, FM	
16	16	x	UL, CE, CSA, FM	16 Configurable Input or Output Channels

In-Cabinet Block

# IN-CABINET BLOCK I/O

## Discrete I/O

- PNP Style I/O\*
- 0.5A Outputs\*
- Fiberglass Reinforced Nylon Housing
- Screw Terminals
- IP20

\* Unless otherwise specified in the notes.



Pictures represent a sampling of housings

Housing Style	Part Number	Protocol
	FDN20-16SN-16XSG	DeviceNet™
	FDN20-32SN	DeviceNet

# DISTRIBUTED I/O SALES GUIDE



Number of Inputs	Number of Outputs	Aux. Power	Certifications	Notes:
32	16	x	UL, CE, CSA	16 PNP/NPN Configurable Inputs, 16 Configurable Input or Output Channels
32		x	CE	PNP/NPN Configurable Inputs

In-Cabinet Block

# On-Machine Modular I/O

On-machine (IP67) modular I/O does not require an enclosure, allowing it to be mounted directly on the machine. TURCK on-machine modular I/O offers quick connection and flexible performance.

## BL67 System

The BL67 system is a completely modular and connectorized I/O system. With IP67-rated protection, the BL67 is rugged enough to be mounted directly on the machine, while flexible enough to handle all of the various I/O signals in the field. Enabling operators to create a unique and custom solution for diverse applications, the BL67 system allows use of any fieldbus gateway with any I/O module, in addition to multiple connectorized bases, depending upon the application.



## BL67 Features

- Multiprotocol gateway with interface to the higher level control system
- Programmable features for local or distributed control
- Mix and match slices to create the ideal mix of I/O
- I/O subnet option to elevate device level I/O to Ethernet
- System can integrate up to 32 slices
- Multiple connectorized bases available, including M12 **eurofast**®, M8 **picofast**®, M23 **multifast**® and 7/8 **minifast**® connections



<b>PRODUCT</b>	<b>PAGE</b>
<b>Part number key</b>	<b>D3</b>
<b>Gateways</b>	<b>D5</b>
<b>Digital I/O slices</b>	<b>D7</b>
<b>Analog and specialty I/O slices</b>	<b>D9</b>
<b>Bases</b>	<b>D11</b>

## BL67 Gateways Part Number Key

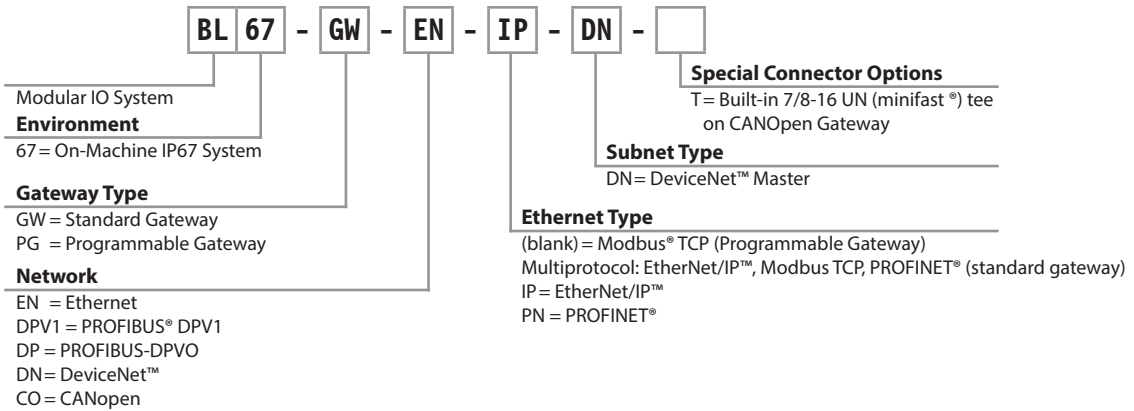

## BL67 Slices Part Number Key

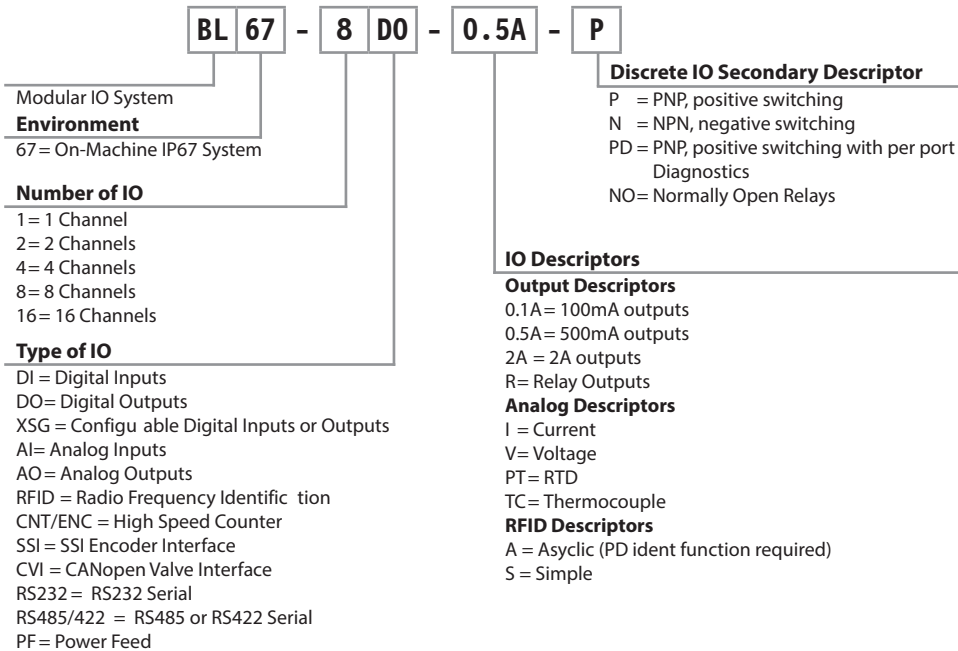

## BL67 Bases Part Number Key

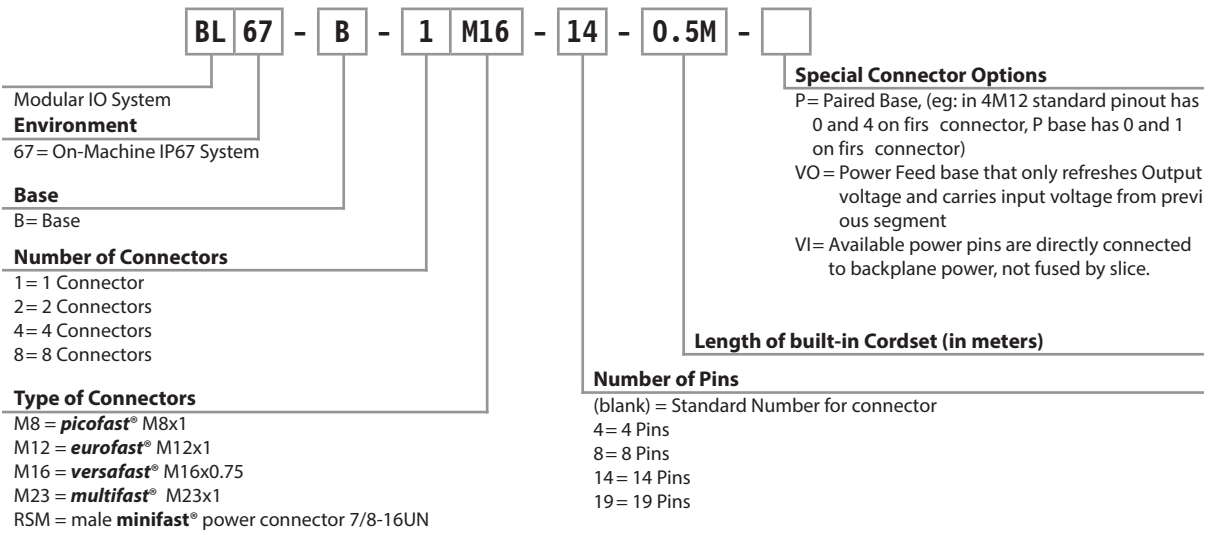

On-Machine Modular

# ON-MACHINE MODULAR I/O

## BL67 Gateways

- IP67 Protection
- Suitable for most On-Machine Applications
- Some Versions Programmable via CoDeSys V2.3
- IEC 61131-3 Programming Structure
- Program in Ladder Logic, Structured Text, or 3 others
- Mix and Match Languages to Suit Application
- Large Library of Pre-written Function Blocks
- Provide Interface between Chosen Network(s) and BL67 I/O
- Up to 32 BL67 Slices can be Used
- Wide Variety of Digital and Analog I/O Available
- Specialty Slices Available inc. RFID, RSXXX, and Encoders



Housing Style	Part Number
	BL67-PG-EN-IP
	BL67-PG-EN
	BL67-PG-EN-IP-DN
	BL67-PG-EN-DN
	BL67-PG-DP
	BL67-GW-EN
	BL67-GW-EN-DN
	BL67-GW-EN-IP-DN
	BL67-GW-DPV1
	BL67-GW-DN
BL67-GW-CO	

# DISTRIBUTED I/O SALES GUIDE



## Physical Characteristics

- Housing is Made of Lexan (PC-V0)
- Operating Temp -45°C to 70°C
- Vibration 5g @ 10-500hz
- LED Indication for Quick Diagnostic
- Rotary Switches for ID Settings
- Clear Window

Slave Functions					
EIP	MB TCP	PN	DP	DN	CO
x					
	x				
x					
	x				
			x		
x	x	x			
		x			
x					
			x		
				x	
					x

Master Functions					Approvals
MB TCP	PCCC	MB RTU	DN	CO	
+	+	+			CE, UL
+	+	+			CE, UL
+	+	+	x	o	CE, UL
+	+	+	x	o	CE
+	+	+			CE, UL
					CE, UL
			x		CE, UL
			x		CE, UL
					CE
					CE, UL
					CE, UL

On-Machine Modular

## BL67 Digital I/O Slices

- IP67 Protection
- M12 eurofast, M8 picofast, and M23 multifast Connectivity
- All I/O Short-circuit Protected
- Separate I/O Electronics and Wiring Base
- PNP and NPN Options
- Multiple Power Options, from 0.1A to 4A
- Combined Input and Output Modules Reduce Inventory Needs
- Deluxe Diagnostics Available to Facilitate Various Power Scenarios



Housing Style	Part Number	Number of Inputs	Number of Outputs	Power of Outputs
	BL67-4DI-P	4		
	BL67-4DI-N	4		
	BL67-4DI-PD	4		
	BL67-8DI-P	8		
	BL67-8DI-N	8		
	BL67-8DI-PD	8		
	BL67-4DO-0.5A-P		4	0.5A
	BL67-4DO-2A-P		4	2A
	BL67-4DO-2A-N		4	2A
	BL67-4DO-4A-P		4	4A
	BL67-8DO-0.5A-P		8	0.5A
	BL67-8DO-0.5A-N		8	0.5A
	BL67-16DO-0.1A-P		16	0.1A
	BL67-4DI4DO-PD	4	4	0.5A
	BL67-8XSG-P	8	8	0.5A
	BL67-8XSG-PD	8	8	0.5A

Type of I/O	Approvals	Deluxe Diagnostics	Base Modules							
			M8 Connectors		M12 Connectors				M23 Connectors	
			BL67-B-4M8	BL67-B-8M8	BL67-B-2M12	BL67-B-2M12-P	BL67-B-4M12	BL67-B-4M12-P	BL67-B-1M23	BL67-B-M23-19
PNP	CE, UL		x		x	x	x		x	
NPN	CE		x		x	x	x		x	
PNP	CE, UL	x	x		x		x			
PNP	CE, UL			x			x	x	x	
NPN	CE, UL			x			x	x	x	
PNP	CE, UL	x		x			x		x	
PNP	CE, UL		x		x	x	x		x	
PNP	CE, UL		x		x	x	x		x	
NPN	CE, UL		x		x	x	x		x	
PNP	CE, UL		x		x	x	x		x	
PNP	CE, UL			x			x	x	x	
NPN	CE, UL			x			x	x	x	
PNP	CE	x								x
PNP	CE	x		x			x	x	x	
PNP	CE, UL			x			x	x	x	
PNP	CE, UL	x		x			x	x		

On-Machine Modular

## BL67 Analog and Specialty I/O Slices

- IP67 Protection
- Configurable Voltage and Current Inputs
- Analog Inputs and Outputs on Same Module Available
- Separate I/O Electronics and Wiring Base
- Thermocouple Types: B, E, J, K, N, R, S, and T
- RTD Types: PT100, PT200, PT500, PT1000, Ni100, Ni1000
- Current Outputs can drive loads of < 0.45 K ohm or < 1mH
- Voltage Outputs can drive loads of < 1 K ohm or < 1 uF
- 99.8% Accuracy
- 16 bit Resolution and Value Representation



\* Max Response Time is the maximum amount of time for an I/O point to respond. This time does not take into account any Fieldbus or Backplane delays, so actual response times will vary.

Housing Style	Part Number	0-20mA Input	4-20mA Input	0-10V Input	-10-10V Input
	BL67-2AI-I	x	x		
	BL67-2AI-V			x	x
	BL67-4AI-V/I	x	x	x	x
	BL67-2AI-TC				
	BL67-2AI-PT				
	BL67-2A0-I				
	BL67-2A0-V				
	BL67-4A0-V				
	BL67-2AI2A0-VI	x	x	x	x
	BL67-4AI4A0-VI	x	x	x	x
	BL67-2RFID-A*				
	BL67-2RFID-S				
	BL67-1RS232				
	BL67-1RS485/422				
	BL67-1SSI				
	BL67-1CNT/ENC				
	BL67-1CVI				
	BL67-PF-24VDC				

\* = Only with Programmable gateways



# ON-MACHINE MODULAR I/O

## BL67 Bases



Housing Style	BL67 Wiring Bases
	<ul style="list-style-type: none"> <li>BL67-B-1M12</li> <li>BL67-B-1M12-8</li> <li>BL67-B-2M12</li> <li>BL67-B-2M12-P</li> <li>BL67-B-4M8</li> <li>BL67-B-1M23</li> <li>BL67-B-1M23-VI</li> <li>BL67-B-1M23-19</li> <li>BL67-B-RSM</li> <li>BL67-B-RSM-4</li> </ul>
	<ul style="list-style-type: none"> <li>BL67-B-4M12</li> <li>BL67-B-4M12-P</li> <li>BL67-B-8M8</li> </ul>

# DISTRIBUTED I/O SALES GUIDE



On-Machine Modular

# On-Machine Block I/O

On-machine (IP67/69K) block I/O does not require an enclosure, allowing it to be mounted directly on the machine. Featuring a hardened and potted enclosure, TURCK on-machine block I/O modules are ideal for use in harsh applications, such as mobile equipment, automotive and food and beverage. Modules offer quick connection and are used as fixed I/O points, with the exception of the TURCK BL compact, which provides flexible modular I/O performance.



## FGEN Ethernet digital block I/O

- Features Multiprotocol capability for Modbus<sup>®</sup> TCP, EtherNet/IP<sup>™</sup> or PROFINET<sup>®</sup>
- Freely configurable I/Os
- Channel-specific diagnostics
- Up to 16 channels



## FDN DeviceNet<sup>™</sup> block I/O

- DeviceNet<sup>™</sup> or Isolated I/O power supply
- Channel- or module-specific diagnostics
- Three housing sizes to support 8 or 16 channels



## BL Compact Flexible block I/O

- Features Multiprotocol capability for Modbus<sup>®</sup> TCP, EtherNet/IP<sup>™</sup> or PROFINET<sup>®</sup>
- Also available in CANopen, DeviceNet<sup>™</sup> and PROFIBUS
- Supports digital, analog, RFID and specialty I/O
- Fully encapsulated module electronics
- Flexibility of modular I/O in a block design



## FLDP/FXDP

- Diagnostics according to PROFIBUS standard
- Freely configurable I/Os
- Channel-specific diagnostics
- Up to 32 channels



## FAS

- Two housing sizes; 4 and 8 port
- Up to 8 channels
- V3.0 compatible



<b>PRODUCT</b>	<b>PAGE</b>
<b>Part number keys</b>	<b>E3</b>
<b>Discrete I/O</b>	<b>E5</b>
<b>Analog/Advanced I/O</b>	<b>E17</b>

# ON-MACHINE BLOCK I/O

## On-Machine Block I/O Part Number Key

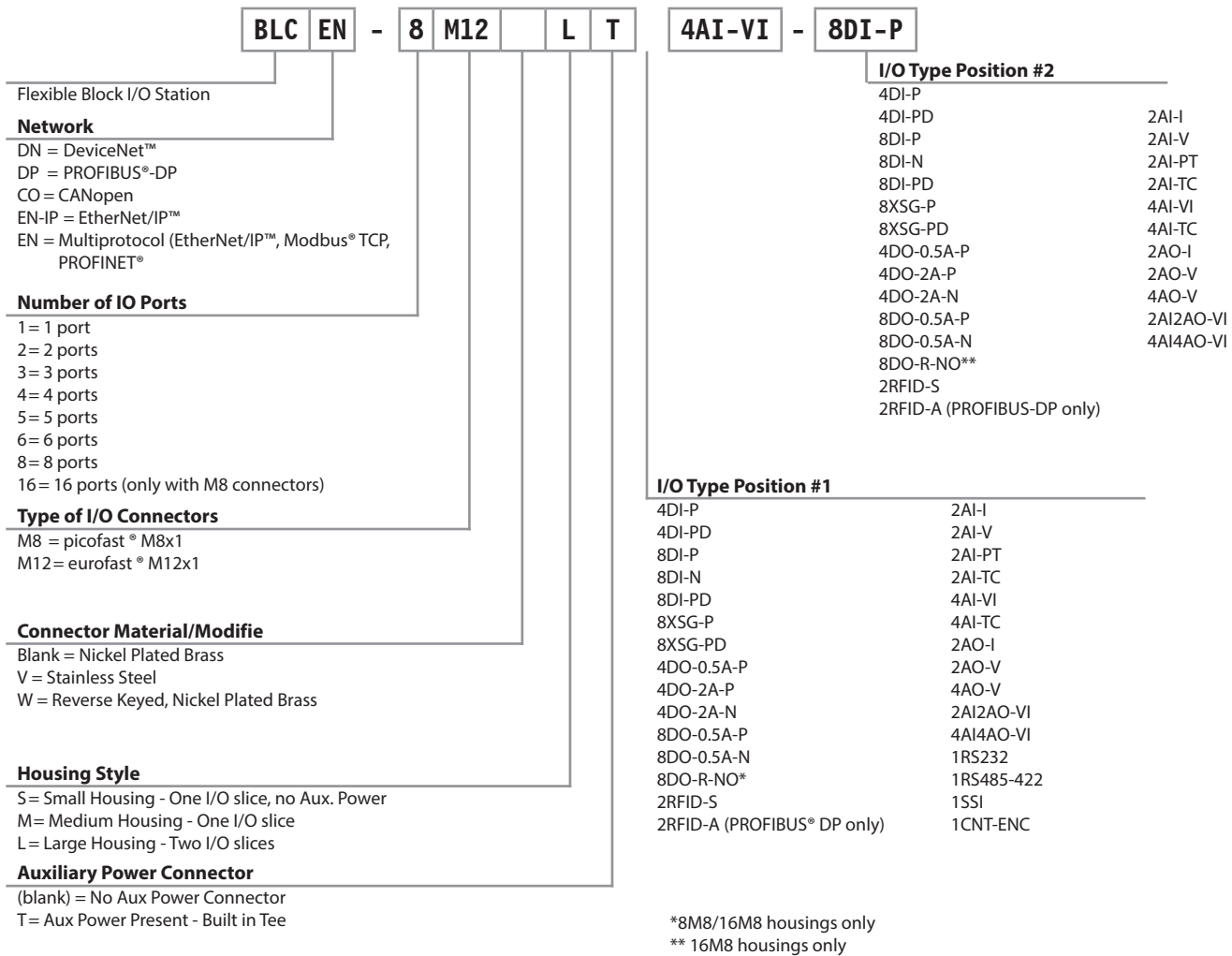

## On-Machine Block I/O Part Number Key

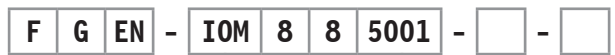

Fixed I/O Station

**Diagnostic Type**  
 L = Standard Diagnostics; Group Diagnostics  
 X = Deluxe Diagnostics; Per Port Input Diagnostics, Per Point Output Diagnostics  
 G = Deluxe Diagnostics; Per Port Input Diagnostics, Per Point Output Diagnostics, 2A outputs, Multiprotocol (EtherNet/IP™, Modbus™ TCP, PROFINET®)

**Network**  
 EN = Ethernet  
 DP = PROFIBUS® DP

**IO Type**  
 XSG = Configurable Input or Output Points  
 IOM = Static Input and Output Points  
 IM = Input Only  
 OM = Output Only

**Subnet Type**  
 DN = DeviceNet™ Master

**Ethernet Type Indicator (X diag. type)**  
 MB = Modbus® TCP  
 IP = EtherNet/IP™  
 PN = PROFINET®  
 PG = Programmable, EtherNet/IP™

**Generic Identify**  
 Refer to documentation for specific

**Number of Output Points**  
 4 = 4 Output Points  
 8 = 8 Output Points  
 12 = 12 Output Points  
 16 = 16 Output Points

**Number of Input Points**  
 8 = 8 Input Points  
 12 = 12 Input Points  
 16 = 16 Input Points  
 20 = 20 Input Points  
 24 = 24 Input Points  
 32 = 32 Input Points



Fixed I/O Station

**Network**  
 DN = DeviceNet™  
 ASi = AS-interface

**Housing Style**  
 P = 8 I/O Ports/Aux power/220 mm long  
 L = 8 I/O Ports/197 mm long  
 Q = 4 I/O Ports/148 mm long  
 4 = 4 I/O Ports/125 mm long (AS-i only)  
 8 = 8 I/O Ports/156 mm long (AS-i only)

**Type of IO**  
 (blank) = non-discrete  
 L = NPN/PNP, Individual Open and Short-circuit Detection  
 P = PNP, Individual Open and Short-circuit Detection  
 S = PNP, Group Short-circuit Detection, Earth Ground Pin 5  
 CPG = Combined - PNP input and Output on same connector  
 CSG = Combined - PNP input and output on separate connectors  
 XSG = Configurable - PNP Input or Output  
 N = NPN, Group Short-circuit Detection, Earth Ground Pin 5  
 E = E-Connect Safety Station

**Number of Inputs**  
 00 = 0 Inputs  
 02 = 2 Inputs  
 04 = 4 Inputs  
 08 = 8 Inputs  
 12 = 12 Inputs  
 16 = 16 Inputs

**Connector Material/Modification**  
 (Blank) = Nickel Plated Brass  
 V = Stainless Steel  
 A = Auxiliary Power (ASi stations only)

**Aux. Power Connector**  
 T = minifast pass through, both male and female  
 M = minifast drop, single male  
 W = minifast drop, single male, rotated keyway  
 C = eurofast pass through, both male and female  
 E = eurofast drop, single male

**DeviceNet Connector Configuration**  
 T = *minifast*® pass through, both male and female  
 S = *minifast* pass through, both male and female, screw terminal through back of module  
 M = *minifast* drop single male  
 W = *minifast* drop, single male rotated keyway  
 C = *eurofast*® pass through, both male and female  
 E = *eurofast* drop, single male

**Analog Description**  
 V/I = Current or voltage

**IO Description**  
 G = 0.5 A Outputs  
 H = 1.4 or 2 A Outputs  
 AI = Analog Input

**Number of Outputs**  
 00 = 0 Outputs  
 02 = 2 Outputs  
 03 = 3 Outputs  
 04 = 4 Outputs  
 08 = 8 Outputs  
 12 = 12 Outputs  
 16 = 16 Outputs

On-Machine Block

# ON-MACHINE BLOCK I/O

## Discrete I/O

- PNP Style I/O\*
- 0.5A Outputs\*
- Fiberglass Reinforced Nylon Housing (fully potted)
- Nickel Plated Brass Connectors\*
- IP67\*

\* Unless otherwise specified in the notes.

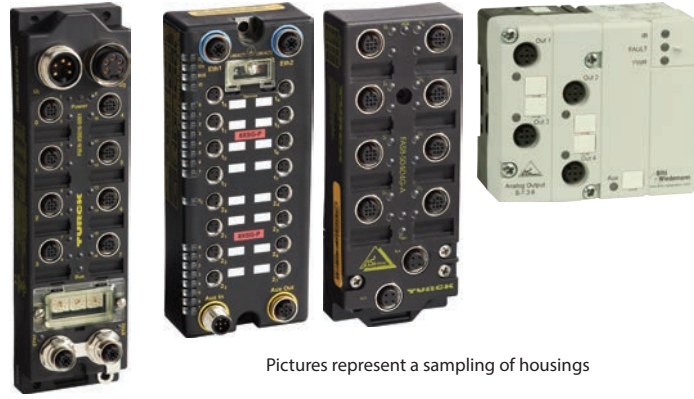

Pictures represent a sampling of housings

Housing Style	Part Number	Protocol	Aux. Power
	FDNL-CSG88-W	DeviceNet™	
	FDNL-L1600-T	DeviceNet	
	FDNL-N1600-T	DeviceNet	
	FDNL-S0808HI-MM	DeviceNet	x
	FDNL-S1600-T	DeviceNet	
	FDNL-S1600-W	DeviceNet	
	FDNL-SN0808N-C	DeviceNet	
	FDNL-XSG16-T	DeviceNet	

# DISTRIBUTED I/O SALES GUIDE



No. of Inputs	No. of Outputs	Deluxe Diagnostics	Certifications	Notes
8	8		UL, CE, CSA	Single 7/8" Fieldbus Connector
16		x	UL, CE, CSA, FM	PNP / NPN Configurable Inputs
16			UL, CE, CSA, FM	NPN Style Inputs
8	8		UL, CE, CSA, FM	High Power 2A Outputs
16			UL, CE, CSA, FM	
16			UL, CE, CSA	Single 7/8" Fieldbus Connector
8	8		UL, CE, CSA, FM	PNP / NPN Configurable Inputs, NPN Outputs, M12 Fieldbus Connectors
16	16		UL, CE, CSA, FM	16 Configurable Input or Output Channels

On-Machine Block

# ON-MACHINE BLOCK I/O

## Discrete I/O

- PNP Style I/O\*
- 0.5A Outputs\*
- Fiberglass Reinforced Nylon Housing (fully potted)
- Nickel Plated Brass Connectors\*
- IP67\*

\* Unless otherwise specified in the notes.

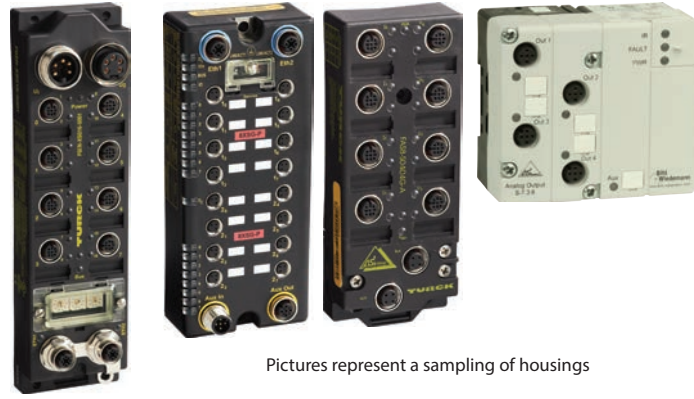

Pictures represent a sampling of housings

Housing Style	Part Number	Protocol	Aux. Power
	FGEN-IM16-4001	Multiprotocol	x
	FGEN-IM16-5001	Multiprotocol	x
	FGEN-IOM88-4001	Multiprotocol	x
	FGEN-IOM88-5001	Multiprotocol	x
	FGEN-OM16-4001	Multiprotocol	x
	FGEN-OM16-5001	Multiprotocol	x
	FGEN-XSG16-4001	Multiprotocol	x
	FGEN-XSG16-5001	Multiprotocol	x
	FDNP-L0808H-TT	DeviceNet™	x
	FDNP-P0808H-TT	DeviceNet	x
	FDNP-S0808G-TT	DeviceNet	x
	FDNP-S0808G-WW	DeviceNet	x
	FDNP-S0808H-WW	DeviceNet	x
	FDNP-XSG16-ST	DeviceNet	x
	FDNP-XSG16-TT	DeviceNet	x
	FLDP-IM 16-0001	PROFIBUS®-DP	x
	FLDP-IOM 88-0002	PROFIBUS-DP	x
	FLDP-OM 16-0001	PROFIBUS-DP	x
	FXDP-IM 16-0001	PROFIBUS-DP	x
	FXDP-IOM 88-0001	PROFIBUS-DP	x
FXDP-OM 16-0001	PROFIBUS-DP	x	
FXDP-XSG16-0001	PROFIBUS-DP	x	

# DISTRIBUTED I/O SALES GUIDE



No. of Inputs	No. of Outputs	Deluxe Diagnostics	Certifications	Notes
16		x	CE	4-pin Aux Power Connectors
16		x	CE	
8	8	x	CE	High Power 2A Outputs, 4-pin Aux Power Connectors
8	8	x	CE	High Power 2A Outputs
	16	x	CE	High Power 2A Outputs, 4-pin Aux Power Connectors
	16	x	CE	High Power 2A Outputs
16	16	x	CE	High Power 2A Outputs, 16 Configurable Input or Output Channels, 4-pin Aux Power Connectors
16	16	x	CE	High Power 2A Outputs, 16 Configurable Input or Output Channels
8	8	x	UL, CE, CSA	PNP / NPN Configurable Inputs, High Power 2A Outputs
8	8	x	UL, CE, CSA	High Power 2A Outputs
8	8		UL, CE, CSA, FM	
8	8		UL, CE, CSA	Single 7/8" Fieldbus Connector, Single 7/8" Aux Power Connector
8	8		UL, CE, CSA	High Power 1.4A Outputs, Single 7/8" Fieldbus Connector, Single 7/8" Aux Power Connector
16	16		UL, CE, CSA	16 Configurable Input or Output Channels , Screw Terminal Connections Out Back
16	16		UL, CE, CSA, FM	16 Configurable Input or Output Channels
16			UL, CE, CSA	
8	8		UL, CE	
	16		UL, CE, CSA	
16		x	UL, CE, CSA	
8	8	x	UL, CE, CSA	High power 1.4A Outputs
	16	x	UL, CE, CSA	High Power 1.4A Outputs
16	16	x	UL, CE, CSA	High power 1.4A Outputs, 16 Configurable Input or Output Channels

On-Machine Block

# ON-MACHINE BLOCK I/O

## Discrete I/O

- PNP Style I/O\*
- 0.5A Outputs\*
- Fiberglass Reinforced Nylon Housing (fully potted)
- Nickel Plated Brass Connectors\*
- IP67\*

\* Unless otherwise specified in the notes.

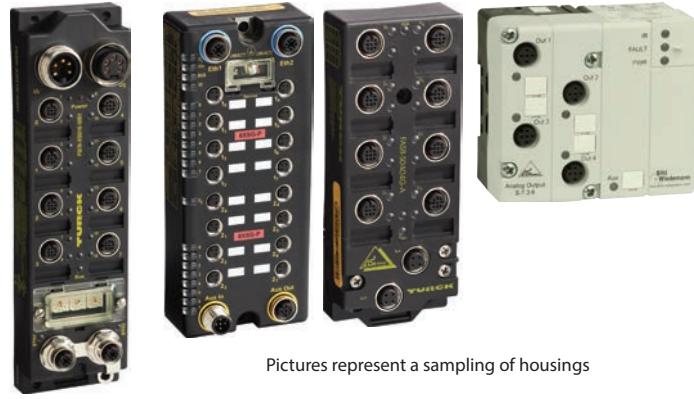

Pictures represent a sampling of housings

Housing Style	Part Number	Protocol	Aux. Power
	FLDP-IM 32-0001	PROFIBUS®-DP	x
	FLDP-IOM 1616-0001	PROFIBUS-DP	x

# DISTRIBUTED I/O SALES GUIDE



No. of Inputs	No. of Outputs	Deluxe Diagnostics	Certifications	Notes
32			UL, CE, CSA	
16	16		UL, CE, CSA	

On-Machine Block

# ON-MACHINE BLOCK I/O

## Discrete I/O

- PNP Style I/O\*
- 0.5A Outputs\*
- Fiberglass Reinforced Nylon Housing (fully potted)
- Nickel Plated Brass Connectors\*
- IP67\*

\* Unless otherwise specified in the notes.

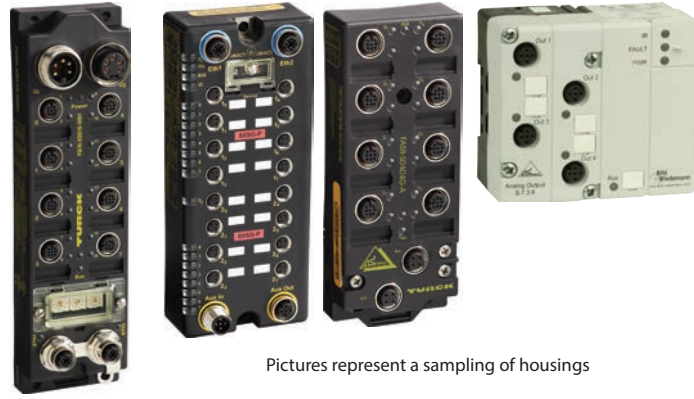

Pictures represent a sampling of housings

Housing Style	Part Number	Protocol	Aux. Power
	BLCEN-16M8LT-8XSG-P-8XSG-P	Multiprotocol	x
	BLCCO-16M8LT-8XSG-P-8XSG-P	CANopen	x
	BLCCO-8M12L-8DI-P-8DI-P	CANopen	
	BLCCO-8M12LT-4D0-0.5A-P-4D0-0.5A-P	CANopen	x
	BLCCO-8M12LT-8XSG-P-8XSG-P	CANopen	x
	BLCDN-16M8L-8DI-N-8DI-N	DeviceNet™	
	BLCDN-16M8L-8DI-P-8DI-P	DeviceNet	
	BLCDN-16M8L-8XSG-P-8XSG-P	DeviceNet	
	BLCDN-16M8LT-8D0-0.5A-N-8D0-0.5A-N	DeviceNet	x
	BLCDN-16M8LT-8D0-0.5A-P-8D0-0.5A-P	DeviceNet	x
	BLCDN-16M8LT-8XSG-P-8XSG-P	DeviceNet	x
	BLCDN-8M12L-8DI-P-8DI-N	DeviceNet	
	BLCDN-8M12LT-4D0-2A-N-4D0-2A-N	DeviceNet	x
	BLCDN-8M12LT-4D0-2A-P-4D0-2A-P	DeviceNet	x
BLCDN-8M12LT-8DI-N-8D0-0.5A-N	DeviceNet	x	
	FDNQ-S0404G-MM	DeviceNet	x
	FDNQ-S0404G-T	DeviceNet	
	FDNQ-S0800-T	DeviceNet	
	FDNQ-XSG08-T	DeviceNet	

# DISTRIBUTED I/O SALES GUIDE



No. of Inputs	No. of Outputs	Deluxe Diagnostics	Certifications	Notes
16	16		UL, CE	16 Configurable Input or Output Channels, M8 I/O connectors
16	16		UL, CE	16 Configurable Input or Output Channels, M8 I/O connectors
16			UL, CE	
	8		UL, CE	
16	16		UL, CE	16 Configurable Input or Output Channels
16			UL, CE	NPN Inputs, M8 I/O Connectors
16			UL, CE	M8 I/O Connectors
16	16		UL, CE	16 Configurable Input or Output Channels, M8 I/O connectors
	16		UL, CE	NPN Style Outputs, M8 I/O Connectors
	16		UL, CE	M8 I/O Connectors
16	16		UL, CE	16 Configurable Input or Output Channels, M8 I/O connectors
16			UL, CE	8 PNP Style Inputs, 8 NPN Style Inputs
	8		UL, CE	High Power 2A Outputs, NPN Style Outputs
	8		UL, CE	High Power 2A Outputs
8	8		UL, CE	NPN Style Input and Output points
4	4		UL, CE, CSA, FM	
4	4		UL, CE, CSA, FM	
8			UL, CE, CSA, FM	
8	8		UL, CE, CSA, FM	8 Configurable Input or Output Channels

On-Machine Block

# ON-MACHINE BLOCK I/O

## Discrete I/O

- PNP Style I/O\*
- 0.5A Outputs\*
- Fiberglass Reinforced Nylon Housing (fully potted)
- Nickel Plated Brass Connectors\*
- IP67\*

\* Unless otherwise specified in the notes.

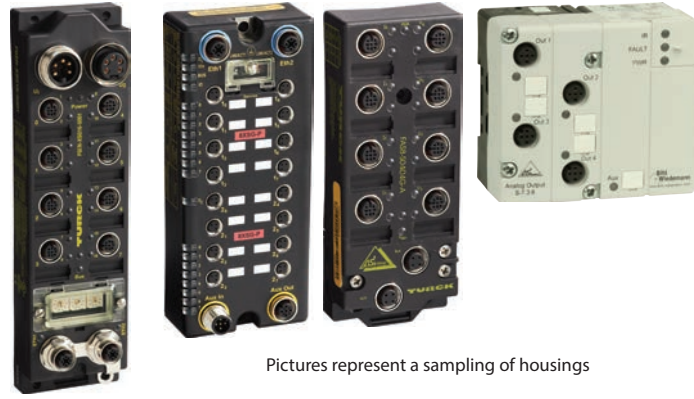

Pictures represent a sampling of housings

Housing Style	Part Number	Protocol	Aux. Power
	BLCCO-4M12S-4DI-P	CANopen	
	BLCCO-4M12S-8XSG-P	CANopen	
	BLCCO-8M8S-8XSG-P	CANopen	
	BLC DN-8M8S-8DI-N	DeviceNet™	
	BLC DN-8M8S-8DI-P	DeviceNet	
	BLC EN-4M12MT-8DI-P	Multiprotocol	x
	BLC EN-4M12MT-8DO-0.5A-P	Multiprotocol	x
	BLC EN-8M8MT-8XSG-P	Multiprotocol	x
	BLCCO-4M12MT-4DO-0.5A-P	CANopen	x
	BLCCO-4M12MT-4DO-2A-P	CANopen	x
	BLC DN-4M12MT-4DO-2A-N	DeviceNet	x
	BLC DN-4M12MT-4DO-2A-P	DeviceNet	x

# DISTRIBUTED I/O SALES GUIDE



No. of Inputs	No. of Outputs	Deluxe Diagnostics	Certifications	Notes
4			UL, CE	
8	8		UL, CE	8 Configurable Input or Output Channels
8	8		UL, CE	8 Configurable Input or Output Channels, M8 I/O Connectors
8			UL, CE	NPN Style Inputs, M8 I/O Connectors
8			UL, CE	M8 I/O Connectors
8			UL, CE	
	8		UL, CE	
8	8		UL, CE	8 Configurable Input or Output Channels, M8 I/O Connectors
	4		UL, CE	
	4		UL, CE	High Power 2A Outputs
	4		UL, CE	High Power 2A Outputs, NPN Style Outputs
	4		UL, CE	High Power 2A Outputs

On-Machine Block

# ON-MACHINE BLOCK I/O

## Discrete I/O

- PNP Style I/O\*
- 0.5A Outputs\*
- Fiberglass Reinforced Nylon Housing (fully potted)
- Nickel Plated Brass Connectors\*
- IP67\*

\* Unless otherwise specified in the notes.

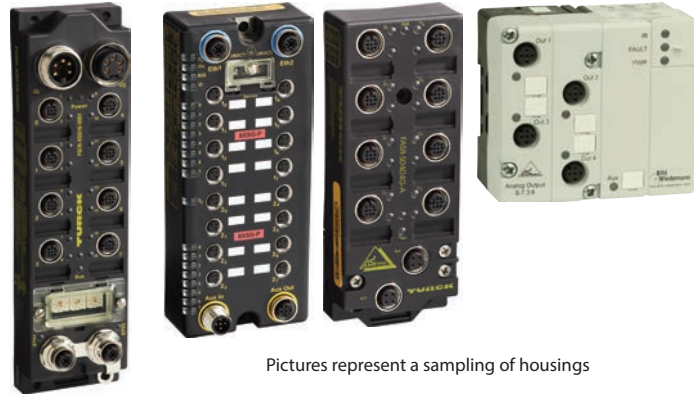

Pictures represent a sampling of housings

Housing Style	Part Number	Protocol	Aux. Power
	FAS4-CSG43-A	AS-I	x
	FAS4-CSG44	AS-I	
	FAS4-CSG44-A	AS-I	x
	FAS4-S0003G-A	AS-I	x
	FAS4-S0400	AS-I	
	FAS8-S0404G-A	AS-I	x
	FAS8-S0404H-A	AS-I	x

# DISTRIBUTED I/O SALES GUIDE



No. of Inputs	No. of Outputs	Deluxe Diagnostics	Certifications	Notes
4	3			AS-I Version 2.1, AB Addressing, 700 mA Outputs
4	4		UL, CSA	AS-I Version 2.1, Single Addressing, 400mA outputs
4	4		UL, CSA	AS-I Version 2.1, Single Addressing, 700 mA outputs
	3		UL, CSA	Output power of 700 mA
4			UL, CSA	
4	4			AS-I Version 3.0, AB Addressing, 700 mA Outputs
4	4			AS-I Version 3.0, AB Addressing, High Power 2A Outputs

On-Machine Block

# ON-MACHINE BLOCK I/O

## Analog/Advanced I/O

- PNP Style Discrete I/O\*
- 0.5A Outputs\*
- Fiberglass Reinforced Nylon Housing (fully potted)\*
- Nickel Plated Brass Connectors\*
- IP69K\*

\* Unless otherwise specified in the notes.



Pictures represent a sampling of housings

Housing Style	Part Number	Protocol	Aux. Power
	BLCCN-6M12LT-2RFID-S-8XSG-P	MultProtocol	x
	BLCCN-3M12LT-1RS232-2RFID-S	Multiprotocol	x
	BLCCN-4M12LT-2AI-PT-2AI-PT	Multiprotocol	x
	BLCCN-4M12LT-2RFID-S-2RFID-S	Multiprotocol	x
	BLCCN-6M12LT-4AI-VI-2A0-I	Multiprotocol	x
	BLCCN-8M12LT-4AI4A0-VI-4AI4A0-VI	Multiprotocol	x
	BLCCN-8M12LT-4AI-VI-4AI-VI	Multiprotocol	x
	BLCCN-IP-8M12LT-4AI-TC-4AI-TC	Multiprotocol	x
	BLCCO-4M12L-2AI-PT-2AI-PT	CANopen	
	BLCCO-4M12L-2RFID-S-2RFID-S	CANopen	
	BLCCO-6M12L-4AI-VI-2A0-I	CANopen	
	BLCCO-6M12LT-2RFID-S-8XSG-P	CANopen	x
	BLCCO-8M12L-4AI-VI-4AI-VI	CANopen	
	BLCCO-8M12LT-4AI-VI-4D0-0.5A-P	CANopen	x
	BLCCO-8M12LT-4AI-VI-8XSG-P	CANopen	x
	BLCDN-4M12L-2AI-PT-2AI-PT	DeviceNet™	
	BLCDN-4M12L-2A0-I-2A0-I	DeviceNet	
	BLCDN-4M12L-2RFID-S-2RFID-S	DeviceNet	
	BLCDN-6M12L-4AI4A0-VI-4DI-P	DeviceNet	
	BLCDN-6M12L-4AI-VI-2A0-I	DeviceNet	
	BLCDN-6M12LT-2RFID-S-8XSG-PD	DeviceNet	x
	BLCDN-8M12L-4AI-TC-4AI-TC	DeviceNet	
	BLCDN-8M12L-4AI-VI-4AI-VI	DeviceNet	
	BLCDN-8M12LT-4AI-VI-8XSG-PD	DeviceNet	x
	BLCDP-4M12LT-2AI-PT-2AI-PT	PROFIBUS-DP	x

# DISTRIBUTED I/O SALES GUIDE



Number of Inputs	Number of Outputs	Number of Tech Channels	Housing Style	Deluxe Diagnostics	Certifications	Notes
8	8	2	D		UL, CE	2 RFID Channels, 8 Configurable Discrete Inputs or Outputs
		3	D		UL, CE	1 RS232 Channel, 2 RFID Channels
4			D		UL, CE	4 RTD Analog Inputs
		4	D		UL, CE	4 RFID Channels
4	2		D		UL, CE	4 Configurable Analog Inputs, 2 Current Analog Outputs
8	8		D		UL, CE	8 Configurable Analog Inputs, 8 Voltage Analog Outputs
8			D		UL, CE	8 Configurable Analog Inputs
8			D		UL, CE	8 Thermocouple Analog Inputs
4			D		UL, CE	4 RTD Analog Inputs
		4	D		UL, CE	4 RFID Channels
4	2		D		UL, CE	4 Configurable Analog Inputs, 2 Current Analog Outputs
8	8	2	D		UL, CE	2 RFID Channels, 8 Configurable Discrete Inputs or Outputs
8			D		UL, CE	8 Configurable Analog Inputs
4	4		D		UL, CE	4 Configurable Analog Inputs, 4 Discrete Outputs
12	8		D		UL, CE	4 Configurable Analog Inputs, 8 Configurable Discrete Inputs or Outputs
4			D		UL, CE	4 RTD Analog Inputs
	4		D		UL, CE	4 Current Analog Outputs
		4	D		UL, CE	4 RFID Channels
8	4		D		UL, CE	4 Configurable Analog Inputs, 4 Voltage Analog Outputs, 4 Discrete Inputs
4	2		D		UL, CE	4 Configurable Analog Inputs, 2 Current Analog Outputs
8	8	2	D	x	UL, CE	2 RFID Channels, 8 Configurable Discrete Inputs or Outputs
8			D		UL, CE	8 Thermocouple Analog Inputs
8			D		UL, CE	8 Configurable Analog Inputs
12	8		D	x	UL, CE	4 Configurable Analog Inputs, 8 Configurable Discrete Inputs or Outputs
4			D		UL, CE	4 RTD Analog Inputs

On-Machine Block

# ON-MACHINE BLOCK I/O

## Analog/Advanced I/O

- PNP Style Discrete I/O\*
- 0.5A Outputs\*
- Fiberglass Reinforced Nylon Housing (fully potted)\*
- Nickel Plated Brass Connectors\*
- IP69K\*

\* Unless otherwise specified in the notes.



Pictures represent a sampling of housings

Housing Style	Part Number	Protocol	Aux. Power
	BLCDP-6M12LT-2AI-PT-8XSG-PD	PROFIBUS®-DP	x
	BLCDP-6M12LT-2A0-I-8XSG-PD	PROFIBUS-DP	x
	BLCDP-6M12LT-2A0-V-8XSG-PD	PROFIBUS-DP	x
	BLCDP-6M12LT-2RFID-S-8XSG-PD	PROFIBUS-DP	x
	BLCDP-8M12LT-4AI-VI-4AI-VI	PROFIBUS-DP	x
	BLCDP-8M12LT-4AI-VI-8XSG-PD	PROFIBUS-DP	x
	BLCCO-2M12S-2A0-V	CANopen	
	BLCCO-2M12S-2RFID-S	CANopen	
	BLCCO-4M12S-4AI-TC	CANopen	
	BLCCO-4M12S-4AI-VI	CANopen	
	BLCDN-2M12S-2AI-PT	DeviceNet™	
	BLCDN-2M12S-2A0-I	DeviceNet	
	BLCDN-2M12S-2A0-V	DeviceNet	
	BLCDN-2M12S-2RFID-S	DeviceNet	
	BLCDN-4M12S-4AI4A0-VI	DeviceNet	
	BLCDN-4M12S-4AI-VI	DeviceNet	
BLCDN-4M12S-4A0-V	DeviceNet		

# DISTRIBUTED I/O SALES GUIDE



Number of Inputs	Number of Outputs	Number of Tech Channels	Housing Style	Deluxe Diagnostics	Certifications	Notes
10	8		D	x	UL, CE	2 RTD Analog Inputs, 8 Configurable Discrete Inputs or Outputs
8	10		D	x	UL, CE	2 Current Analog Outputs, 8 Configurable Discrete Inputs or Outputs
8	10		D	x	UL, CE	2 Voltage Analog Outputs, 8 Configurable Discrete Inputs or Outputs
8	8	2	D	x	UL, CE	2 RFID Channels, 8 Configurable Discrete Inputs or Outputs
8			D		UL, CE	8 Configurable Analog Inputs
12	8		D	x	UL, CE	4 Configurable Analog Inputs, 8 Configurable Discrete Inputs or Outputs
	2		F		UL, CE	2 Voltage Analog Outputs
		2	F		UL, CE	2 RFID Channels
4			F		UL, CE	4 Thermocouple Analog Inputs
4			F		UL, CE	4 Configurable Analog Inputs
2			F		UL, CE	2 RTD Analog Inputs
	2		F		UL, CE	2 Current Analog Outputs
	2		F		UL, CE	2 Voltage Analog Outputs
		2	F		UL, CE	2 RFID Channels
4	4		F		UL, CE	4 Configurable Analog Inputs, 4 Voltage Analog Outputs
4			F		UL, CE	4 Configurable Analog Inputs
	4		F		UL, CE	4 Voltage Analog Outputs

On-Machine Block

# ON-MACHINE BLOCK I/O

## Analog/Advanced I/O

- PNP Style Discrete I/O\*
- 0.5A Outputs\*
- Fiberglass Reinforced Nylon Housing (fully potted)\*
- Nickel Plated Brass Connectors\*
- IP69K\*

\* Unless otherwise specified in the notes.



Pictures represent a sampling of housings

Housing Style	Part Number	Protocol	Aux. Power
	BLCEN-1M12MT-1RS232	Multiprotocol	x
	BLCEN-1M12MT-1RS485-422	Multiprotocol	x
	BLCEN-1M12MT-1SSI	Multiprotocol	x
	BLCEN-2M12MT-2AI-PT	Multiprotocol	x
	BLCEN-2M12MT-2RFID-S	Multiprotocol	x
	BLCEN-4M12MT-4AI4A0-VI	Multiprotocol	x
	BLCEN-4M12MT-4AI-TC	Multiprotocol	x
	BLCEN-4M12MT-4AI-VI	Multiprotocol	x
	BLCEN-4M12MT-4A0-V	Multiprotocol	x
	BLCDP-1M12MT-1SSI	PROFIBUS®-DP	x
	BLCDP-2M12MT-2RFID-S	PROFIBUS-DP	x
	BLCDP-4M12MT-4AI4A0-VI	PROFIBUS-DP	x
	BLCDP-4M12MT-4AI-TC	PROFIBUS-DP	x
	BLCDP-4M12MT-4AI-VI	PROFIBUS-DP	x
BLCDP-4M12MT-4A0-V	PROFIBUS-DP	x	
	ASI-AI-4-M12 BW1359	AS-I	x
	ASI-AI-4-M12 BW1360	AS-I	x
	ASI-AI-4PT100-M12 BW2532	AS-I	
	ASI-A0-4-M12 BW1361	AS-I	x
	ASI-A0-4-M12 BW1362	AS-I	x

# DISTRIBUTED I/O SALES GUIDE



Number of Inputs	Number of Outputs	Number of Tech Channels	Housing Style	Deluxe Diagnostics	Certifications	Notes
		1	G		UL, CE	1 RS232 Channel
		1	G		UL, CE	1 RS485/422 Channel
		1	G		UL, CE	1 SSI Channel
2			G		UL, CE	2 RTD Analog Inputs
		2	G		UL, CE	2 RFID Channels
4	4		G		UL, CE	4 Configurable Analog Inputs, 4 Voltage Analog Outputs
4			G		UL, CE	4 Thermocouple Analog Inputs
4			G		UL, CE	4 Configurable Analog Inputs
	4		G		UL, CE	4 Voltage Analog Outputs
		1	G		UL, CE	1 SSI Channel
		2	G		UL, CE	2 RFID Channels
4	4		G		UL, CE	4 Configurable Analog Inputs, 4 Voltage Analog Outputs
4			G		UL, CE	4 Thermocouple Analog Inputs
4			G		UL, CE	4 Configurable Analog Inputs
	4		G		UL, CE	4 Voltage Analog Outputs
4			J		UL, CE	4 to 20mA Analog Inputs, AS-I Ver 2.1, Single Addressing Style, 7.3-E Slave Profile, IP65
4			J		UL, CE	0 to 10V Analog Inputs, AS-I Ver 2.1, Single Addressing Style, 7.3-E Slave Profile, IP65
4			J		UL, CE	RTD Analog Inputs, AS-I Ver 2.1, Single Addressing Style, 7.3-E Slave Profile, IP65
	4		J		UL, CE	0 to 20mA Analog Outputs, AS-I Ver 2.1, Single Addressing Style, 7.3-6 Slave Profile, IP65
	4		J		UL, CE	0 to 10V Analog Outputs, AS-I Ver 2.1, Single Addressing Style, 7.3-6 Slave Profile, IP65

On-Machine Block

# ON-MACHINE BLOCK I/O

## Analog/Advanced I/O

- PNP Style Discrete I/O\*
- 0.5A Outputs\*
- Fiberglass Reinforced Nylon Housing (fully potted)\*
- Nickel Plated Brass Connectors\*
- IP69K\*

\* Unless otherwise specified in the notes.



Pictures represent a sampling of housings

Housing Style	Part Number	Protocol	Aux. Power
	ASI-AI-02-M12-V3 BW1893	AS-I	
	ASI-AI-02-M12-V3 BW1963	AS-I	
	ASI-AI-02RTD-M12-V3 BW1895	AS-I	

# DISTRIBUTED I/O SALES GUIDE



Number of Inputs	Number of Outputs	Number of Tech Channels	Housing Style	Deluxe Diagnostics	Certifications	Notes
2			K		UL, CE	4 to 20mA Analog Inputs, AS-I Ver 3.0, AB Addressing Style, 7.A-9 Slave Profile, IP65
2			K		UL, CE	0 to 10V Analog Inputs, AS-I Ver 3.0, AB Addressing Style, 7.A-9 Slave Profile, IP65
2			K		UL, CE	RTD Analog Inputs, AS-I Ver 3.0, AB Addressing Style, 7.A-9 Slave Profile, IP65

On-Machine Block

# RFID

Radio frequency identification (RFID) transfers data through tags or transceivers, allowing users to read the authenticity onto the tag and write them to a data carrier. With diverse I/O capabilities, TURCK RFID systems provide superior communication and connectivity for maximum performance.



## ***BL ident***<sup>®</sup>

TURCK's *BL ident*<sup>®</sup> RFID system is an all-in-one RFID system designed for industrial applications. Featuring built-in I/O capabilities, the system is based on TURCK's BL67 on-machine and BL20 in-cabinet modular I/O systems, in addition to the *BL Compact* on-machine block I/O system. *BL ident* offers the following features:

- Consists of data carriers (tags), read/write heads (transceivers), connectivity and communication interface (gateway and RFID modules)
- Multiple fieldbus standards, including PROFIBUS<sup>®</sup>-DP, Ethernet/IP<sup>™</sup>, Modbus<sup>®</sup> TCP, DeviceNet<sup>™</sup>, PROFINET<sup>™</sup>, EtherCAT<sup>™</sup> and CANopen
- Highest flexibility for system integration
- Addition of I/O modules on the same gateway bus node
- Easy integration in the existing control system
- HF and UHF read/write heads can be connected to the same interface
- Parallel processing of data with up to 16 channels per node
- Rated IP20 and IP67

### **Interfaces**

- Modular concept (BL20 and BL67) with up to 20 channels per gateway
- BL20 for in-cabinet mounting
- BL67 and BL Compact for on-machine mounting
- Cable length to the read/write head up to 50 m
- Versatile and simple fieldbus connection (PROFIBUS-DP, DeviceNet, CANopen, PROFINET, Modbus TCP, EtherCAT, EtherNet/IP)
- Programmable gateways for distributed and/or independent control

### **Data Carriers**

- Small housings, as low as 7.5 mm
- EEPROM data carrier for large quantities
- FRAM data carrier for high-speed transmission and many write cycles
- High temperature data carriers -40 to 300 degrees Celsius
- Data carriers for autoclaves, water-vapor tight up to 121 degrees Celsius
- Direct mounting on metal
- Customer-specific solutions based on open and international standards (ISO 15693 and ISO 18000-6C)

### **Read/Write Heads**

- Robust industrial design
- Fully encapsulated read/write heads
- Read/write distances for HF up to 750 mm
- Read/write distances for UHF up to 6 m
- Wash-Down (IP69K)



<b>PRODUCT</b>	<b>PAGE</b>
<b>Part Number Keys</b>	<b>F3</b>
<b>TAGs</b>	<b>F5</b>
<b>Transceivers</b>	<b>F10</b>
<b>Handhelds</b>	<b>F14</b>

# IDENTIFICATION (RFID)

## RFID Transceivers Part Number Key

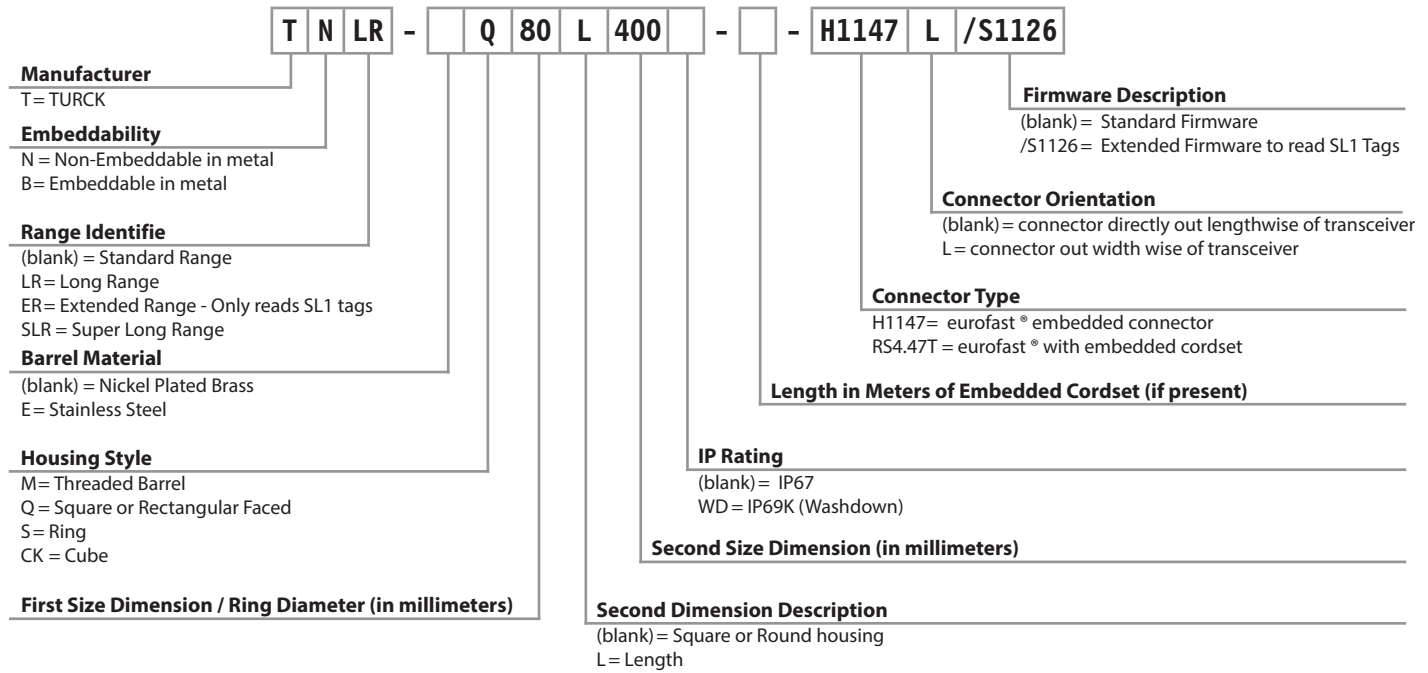

## RFID TAGS Part Number Key

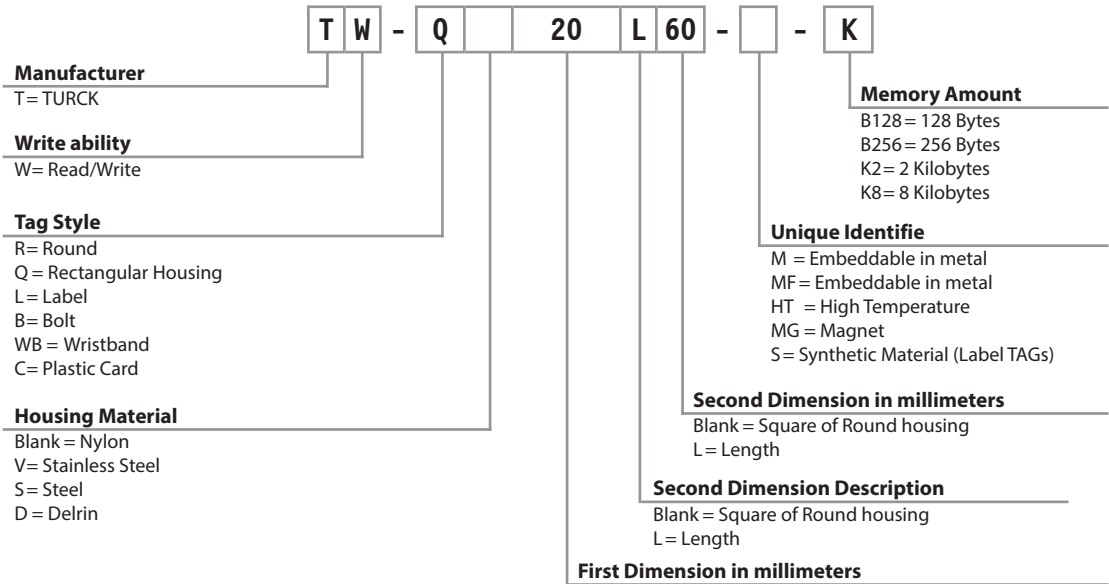

Identification (RFID)

# IDENTIFICATION (RFID)

## HF TAGS

### B128 and B256 TAGs

- EEPROM Memory
- Unlimited Reads
- 100,000 Writes
- 3ms/byte Access Time
- Temperature: -25°C to 85°C Unless Noted
- All TAGs Preprogrammed with Unique Identifier
- ISO 15693 Protocol Standard

### K2 & K8 TAGs

- FRAM Memory
- Unlimited Reads
- Unlimited Writes
- 0.5ms/byte Access Time
- Temperature: -25°C to 85°C Unless Noted
- All TAGs Preprogrammed with Unique Identifier
- ISO 15693 Protocol Standard



Housing Style	Part Number	Description
	TW-R4-22-B128	Glass pill form factor, FDA approved
	TW-R7.5-B128	Tiny form factor
	TW-R16-B128	Good temperature response, smallest hardened form factor, 16 mm in diameter
	TW-R16-K2	Good temperature response, smallest hardened form factor, 16mm in diameter
	TW-R20-B128	Rounded hardened epoxy tag, 20mm
	TW-R20-K2	Rounded hardened epoxy tag, 20mm
	TW-R30-B128	Smallest round tag with center mounting hole, 30mm in diameter
	TW-R30-K2	Smallest round tag with center mounting hole, 30mm in diameter
	TW-R50-B128	Largest round hardened epoxy tag, 50mm in diameter
	TW-R50-K2	Largest round hardened epoxy tag, 50mm in diameter

# DISTRIBUTED I/O SALES GUIDE



## HF TAGS

### B128 and B256 TAGS

- EEPROM Memory
- Unlimited Reads
- 100,000 Writes
- 3ms/byte Access Time
- Temperature: -25°C to 85°C Unless Noted
- All TAGs Preprogrammed with Unique Identifier
- ISO 15693 Protocol Standard

### K2 & K8 TAGS

- FRAM Memory
- Unlimited Reads
- Unlimited Writes
- 0.5ms/byte Access Time
- Temperature: -25°C to 85°C Unless Noted
- All TAGs Preprogrammed with Unique Identifier
- ISO 15693 Protocol Standard



Housing Style	Part Number	Description
	TW-Q20L60-B128	Inexpensive mount on metal option, example of reusing existing parts
	TW-Q51-HT-B128	High Temperature hardened tag up to 210°C
	TW-C56-28-B256	Tag suitable for carrying on key chain
	TW-C74-34-B256	Tag designed for tagging plastic pallets or totes
	TW-C85-54-B256	Credit card style tag

Identification (RFID)

# IDENTIFICATION (RFID)

## HF TAGS

### B128 and B256 TAGs

- EEPROM Memory
- Unlimited Reads
- 100,000 Writes
- 3ms/byte Access Time
- Temperature: -25°C to 85°C Unless Noted
- All TAGs Preprogrammed with Unique Identifier
- ISO 15693 Protocol Standard

### K2 & K8 TAGs

- FRAM Memory
- Unlimited Reads
- Unlimited Writes
- 0.5ms/byte Access Time
- Temperature: -25°C to 85°C Unless Noted
- All TAGs Preprogrammed with Unique Identifier
- ISO 15693 Protocol Standard



Housing Style	Part Number	Description
	TW-L36-18-S-B128	Small form factor label tag with adhesive
	TW-L43-43-S-B128	Larger form factor label tag with adhesive
	TW-BP12x1-S-B128	Plastic bolt tag made out of the existing VZ3 plugs
	TW-BS8x1.25-19-K2	M8 Bolt tag in Steel housing with 2 Kbytes of Memory
	TW-BD10x1.5-19-B128	M10 Bolt tag in Delrin Housing with 128 bytes of Memory
	TW-BD10x1.5-19-K2	M10 Bolt tag in Delrin Housing with 2 Kbytes of Memory
	TW-BS10x1.5-19-B128	M10 Bolt tag in Steel Housing with 128 bytes of Memory
	TW-BS10x1.5-19-K2	M10 Bolt tag in Steel Housing with 2 Kbytes of Memory
	TW-BV10x1.5-19-B128	M10 Bolt tag in Stainless Steel Housing with 128 bytes of Memory
	TW-BV10x1.5-19-K2	M10 Bolt tag in Stainless Steel Housing with 2 Kbytes of Memory
	TW-SPP18x1-B128	Small form factor tag that is designed for autoclave applications with slightly elevated heat and pressure requirements

# DISTRIBUTED I/O SALES GUIDE



Industrial Automation

## HF TAGS

### B128 and B256 TAGS

- EEPROM Memory
- Unlimited Reads
- 100,000 Writes
- 3ms/byte Access Time
- Temperature: -25°C to 85°C Unless Noted
- All TAGs Preprogrammed with Unique Identifier
- ISO 15693 Protocol Standard

### K2 & K8 TAGS

- FRAM Memory
- Unlimited Reads
- Unlimited Writes
- 0.5ms/byte Access Time
- Temperature: -25°C to 85°C Unless Noted
- All TAGs Preprogrammed with Unique Identifier
- ISO 15693 Protocol Standard



Housing Style	Part Number	Description
	TW-WB202-15-B128	Rubber wristband with embedded RFID tag for personnel tracking
	TW-R50-MG25-B128	R50 tag mounted to a spacer and 25lb pull magnet for easy installation

## UHF TAGS

- EEPROM Memory
- Unlimited Read Operations
- 100,000 Write Operations
- Temperature Range -40° to +80°C(unless noted)
- ISO 18000-6C, EPC Global Gen 2 Protocol Standards



Identification (RFID)

Housing Style	Part Number	Description
	TW902-928-R50-B110	Round hardened epoxy tag with mounting hole
	TW860-960-Q51-HT-B110	High temperature hardened tag

# IDENTIFICATION (RFID)

## UHF TAGS

- EEPROM Memory
- Unlimited Read Operations
- 100,000 Write Operations
- Temperature Range -40° to +80°C(unless noted)
- ISO 18000-6C, EPC Global Gen 2 Protocol Standards



Housing Style	Part Number	Description
	TW860-960-Q27L97-M-B112	Suited for outdoor applications. Direct mounting on metal
	TW902-928-Q14L60-M-B110	Plastic housing. Direct mounting on metal
	TW902-928-Q27-M-B112	Small housing. Only for direct mounting on metal
	TW860-960-Q25L77-B-B112	Flexible plastic housing for mounting on curved or irregular surfaces
	TW865-928-L76-18-21-F-M-B110	Label for direct mounting on metal
	TW860-960-L97-15-F-B28	Low cost adhesive sticker tag

# DISTRIBUTED I/O SALES GUIDE



## HF Transceivers

- Robust Industrial Design Based on Field-proven Housings
- Fully Encapsulated Design for IP67, IP68 and IP69K Environments
- Several HF Options Available for Flexible Read/Write Ranges, Mounting Configurations, and Environments
- Shielded Serial Communication to the Fieldbus Level Allows for Remote Mounting up to 50m
- Compact UHF Read/Write Heads for Long-range Applications
- Hazardous Location Options Available



Housing Style	Part Number	Description
	TN-Q14-0.15M-RS4.47T	Small 14mm flat sensor housing with built in cordset
	TB-M18-H1147	18mm Barrel housing completed shielded for flush mounting
	TN-M18-H1147	18mm Barrel housing unshielded for non-flush mounting
	TB-M30-H1147	30mm Barrel housing completed shielded for flush mounting
	TN-M30-H1147	30mm Barrel housing unshielded for non-flush mounting

Identification (RFID)

# IDENTIFICATION (RFID)

## HF Transceivers

- Robust Industrial Design Based on Field-proven Housings
- Fully Encapsulated Design for IP67, IP68 and IP69K Environments
- Several HF Options Available for Flexible Read/Write Ranges, Mounting Configurations, and Environments
- Shielded Serial Communication to the Fieldbus Level Allows for Remote Mounting up to 50m
- Compact UHF Read/Write Heads for Long-range Applications
- Hazardous Location Options Available



Housing Style	Part Number	Description
	TN-CK40-H1147	40mm Cube sensor housing with rotatable connector
	TNSLR-Q42TWD-H1147	42mm Cube sensor housing tuned for longer ranges
	TN-Q80-H1147	80mm puck sensor housing
	TN-S32XL-H1147	100mm ring sensor housing

# DISTRIBUTED I/O SALES GUIDE



## HF Transceivers

- Robust Industrial Design Based on Field-proven Housings
- Fully Encapsulated Design for IP67, IP68 and IP69K Environments
- Several HF Options Available for Flexible Read/Write Ranges, Mounting Configurations, and Environments
- Shielded Serial Communication to the Fieldbus Level Allows for Remote Mounting up to 50m
- Compact UHF Read/Write Heads for Long-range Applications
- Hazardous Location Options Available



Housing Style	Part Number	Description
	TNLR-Q80L400-H1147	400mm x 80mm long sensor housing for use on roll conveyors
	TNLR-Q80L400-H1147L	400mm long sensor housing with M12 connector mounted on side of housing instead of end of housing
	TNLR-Q350-H1147	350mm x 350mm large sensor housing for long range
	TNSLR-Q350-H1147	350mm x 350mm large sensor housing with special hardware and firmware for extra long range

Identification (RFID)

# IDENTIFICATION (RFID)

## UHF Transceivers

- Robust Industrial Design Based on Field-proven Housings
- Fully Encapsulated Design for IP67 Environments
- Several HF Options Available for Flexible Read/Write Ranges, Mounting Configurations, and Environments
- Shielded Serial Communication to the Fieldbus Level Allows for Remote Mounting up to 50m
- Compact UHF Read/Write Heads for Long-range Applications
- Hazardous Location Options Available



Housing Style	Part Number	Description
	<p><b>TN902-Q240L280-H1147</b></p>	<p>240 mm x 280 mm housing for long range applications</p>
	<p><b>TN902-Q175L200-H1147</b></p>	<p>175 mm x 200 mm smaller housing</p>

# DISTRIBUTED I/O SALES GUIDE



## Handhelds

- Mobile Reading and Writing Data to TURCK Data Carriers
- Handheld for Programming
- Customized Software Solutions on Request
- Bluetooth Interface
- IP65
- Included Docking Station with Power Supply



Part Number	
PDA67-IDENT-INT-HF	RFID Software for reading and writing, fold-out antenna
PD-IDENT-WLAN	RFID Software for reading and writing, fold-out antenna, WLAN
PD-IDENT-HF-RBTW	HF RFID Handheld, RFID-OEM software demo, Microsoft CE 5, barcode and GPS options
PD-IDENT-HF-RBSUP	HF RFID Handheld with Pistol Grip, barcode options available
PD-IDENT-UHF-RBTW-915-920	UHF RFID Handheld, RFID-OEM software demo, Microsoft CE 5, barcode and GPS options

Identification (RFID)

# Accessories

At TURCK, we understand that not every application is the same, that's why we dedicate ourselves to finding the optimal engineered solution. TURCK offers a variety of accessories, ranging from software and junction boxes to power supplies and cables to compliment your networking solution.

## Software



### I/O-Assistant/PACTWARE

Download at [www.turck.us](http://www.turck.us)

- FDT/DTM-based technology
- Engineering, configuring, commissioning and diagnosing



### CoDeSys

Download at [www.turck.us](http://www.turck.us)

- IEC 61131-3-based programming software
- Programming in Ladder, Structured List, Flow Chart, Sequential Function and Statement List

PRODUCT	PAGE
<b>Active Junction Boxes</b>	
<b>Repeaters</b>	<b>G5</b>
<ul style="list-style-type: none"><li>• Available for DeviceNet, PROFIBUS®-DP and AS-interface®</li><li>• IP20 and IP67 protection ratings for in-cabinet or on-machine mounting</li></ul>	
<b>Power Supplies</b>	
<b>On-machine</b>	<b>G11</b>
<ul style="list-style-type: none"><li>• IP67 protection rating</li><li>• 2, 4, 8, 12, 15 and 16 Amp outputs</li></ul>	
<b>In-cabinet</b>	<b>G13</b>
<ul style="list-style-type: none"><li>• IP20 protection rating for DIN-rail mounting</li><li>• Up to 20 Amp outputs, universal (AC/DC) voltage input</li></ul>	

# ACCESSORIES

Notes:

## Power Supplies Part Number Key

PSU 67 - 1 1 - 24 4 0 /M

**Power Supply Unit**  
PSU

**Environment**  
67 = On Machine Mountable - IP67

**Number of Input Connectors**  
1 = 1 Input Connector

**Number of Output Connectors**  
1 = 1 Output Connector  
2 = 2 Output Connectors

**Type of Connectors**  
M = minifast® 7/8-16UN

**Connector Material**  
0 = Nickel Plated Brass

**Output Current Rating**  
2 = 2 Amps      12 = 12 Amps  
4 = 4 Amps      15 = 15 Amps  
8 = 8 Amps      16 = 16 Amps

**Output Voltage**  
24 = 24 VDC  
12 = 12 VDC



# ACCESSORIES

## DeviceNet™, Repeater and Spanner module

- Repeater to Extend Trunk or Drop Lines
- Spanner Module to Route Data between Two PLCs over DeviceNet
- Fiberglass Reinforced Nylon Housing (fully potted) with Nickel-brass Connectors
- IP67

Housing Style	Part Number	Protocol
	FDN-DN1	DeviceNet™
	REP-DN	DeviceNet

# DISTRIBUTED I/O SALES GUIDE



Pictures represent a sampling of housings

Connector/Gland Material	Housing Material	Certifications	Notes
Nickle-Brass	Nylon	UL, CE, CSA, FM	Spanner Module, IP67 Fully Potted
Nickle-Brass	Nylon	UL, CE, CSA, FM	Repeater, IP67 Fully Potted

Accessories

# ACCESSORIES

## PROFIBUS®-DP, Repeater

- Repeater to Extend Trunk or Drop Lines
- Automatic Baud Rate Detection up to
- 12 Mbaud
- Fiberglass Reinforced Nylon Housing (fully potted) with Nickel-brass Connectors
- IP67

Housing Style	Part Number	Protocol
<p>5.829 [148.1] REF</p> <p>5.390 [136.9]</p> <p>MOUNTING HOLES: Ø.213 [Ø5.4] 2x Ø.181 [4.6] 1x</p> <p>1.654 [42.0]</p> <p>2.362 [60.0] REF</p> <p>1.063 [27.0] REF</p>	<p>REP-DP-0002</p>	<p>PROFIBUS-DP</p>
<p>3.898 [99.0]</p> <p>.890 [22.6]</p> <p>4.213 [107.0] REF</p>	<p>PB-XEPI2</p>	<p>PROFIBUS-DP</p>

# DISTRIBUTED I/O SALES GUIDE



Pictures represent a sampling of housings

Connector/Gland Material	Housing Material	Certifications	Notes
Nickle-Brass	Nylon	CE	Repeater, IP67 Fully Potted
Nickle-Brass	Nylon		Ethernet to PROFIBUS-DP Interface, IP20



Accessories

# ACCESSORIES

## PROFIBUS® Diagnostic tool

- Ethernet on PROFIBUS Interface
- Central Field Device Configuration, Parameterization and Diagnosis

Housing Style	Part Number	Protocol
	SPTC2/C1243	DeviceNet™
	SPTE1-A48	PROFIBUS PA
	SPTE1-A49	Foundation™ Fieldbus
	SPTM1-A48	PROFIBUS PA
	SPTM1-A49	Foundation Fieldbus
	SPTSM13-A25	AS-I
	SPTT1	DeviceNet
	SPTT1-A25	AS-I
	SPTT1-A48	PROFIBUS PA
	SPTT1-A49	Foundation Fieldbus
	PSU67-11-1240/M	Power Supply
	PSU67-11-2420/M	Power Supply
	PSU67-11-2440/M	Power Supply

# DISTRIBUTED I/O SALES GUIDE



Industrial Automation



Pictures represent a sampling of housings

Connector/Gland Material	Housing Material	Certifications	Notes
Nickle-Brass	Aluminum		Power Tap: 4-pin Male Power Connector, 2 Female Buss Connectors, IP67
SS	Aluminum		Tee: M12 Eurofast Bus Connectors, IP67
SS	Aluminum		Tee: M12 Eurofast Buss Connectors, IP67
SS	Aluminum		Tee, IP67
SS	Aluminum		Tee, IP67
Nylon	Aluminum		Field wireable Tee: Screw Terminals, IP67
Nickle-Brass	Aluminum		Field wireable Tee, IP67
Nylon	Aluminum		Field wireable Tee, IP67
Nylon	Aluminum		Field wireable Tee, IP67
Nylon	Aluminum		Field wireable Tee, IP67
Nickle-Brass	Nylon		12VDC, 4A supply, 3-pin power input to a 4-pin power output, IP67 Fully Potted
Nickle-Brass	Nylon		24VDC, 2A supply, 3-pin power input to a 4-pin power output, IP67 Fully Potted
Nickle-Brass	Nylon		24VDC, 4A supply, 3-pin power input to a 4-pin power output, IP67 Fully Potted



Accessories

# ACCESSORIES

## On-Machine Power Supplies

- 2, 4 and 8 Amp Output Current Available
- Universal Operating Voltage
- Broad Temperature Range
- IP67

Housing Style	Part Number	Protocol
	PSU67-11-2480/M	Power Supply
	PSU67-12-2480/M	Power Supply
	IM82-24-2.5	Power Supply

# DISTRIBUTED I/O SALES GUIDE



Pictures represent a sampling of housings

Connector/Gland Material	Housing Material	Certifications	Notes
Nickle-Brass	Nylon		24VDC, 8A supply, 3-pin power input to a 4-pin power output, IP67 Fully Potted
Nickle-Brass	Nylon		24VDC, 8A supply, 3-pin power input to two 4-pin power outputs, IP67 Fully Potted
Nylon	Aluminum		24 VDC, 2.5A supply, IP20

Accessories

# ACCESSORIES

## In-Cabinet Power Supplies

- 2.5, 5, 10 and 20 Amp Current Available
- Universal Operating Voltage
- Single/parallel Operation
- IP20

Housing Style	Part Number	Protocol
	<p>IM82-24-5.0</p>	<p>Power Supply</p>

# DISTRIBUTED I/O SALES GUIDE



Pictures represent a sampling of housings

Connector/Gland Material	Housing Material	Certifications	Notes
Nylon	Aluminum	UL, CE	24 VDC, 5.0A supply, IP20



Accessories

# ACCESSORIES

## In-Cabinet Power Supplies

- 2.5, 5, 10 and 20 Amp Current Available
- Universal Operating Voltage
- Single/parallel Operation
- IP20

Housing Style	Part Number	Protocol
	<p><b>IM82-24-10</b></p>	<p>Power Supply</p>
	<p><b>IM82-24-20</b></p>	<p>Power Supply</p>

# DISTRIBUTED I/O SALES GUIDE



Pictures represent a sampling of housings

Connector/Gland Material	Housing Material	Certifications	Notes
Nylon	Aluminum	UL, CE	24 VDC, 10A supply, IP20
Nylon	Aluminum	UL, CE	24 VDC, 20A supply, IP20



Accessories

# Network Media

TURCK offers a complete line of molded industrial networking cordsets to aid network installation, providing easier startup with fewer wiring errors. We are dedicated to providing solutions and support the most common protocols including Ethernet, PROFINET™, DeviceNet™, CANopen, FOUNDATION™ Fieldbus and AS-Interface®.



## Industrial Ethernet Cordsets including PROFINET

---

- TPE jacketing provides excellent flexibility and resistance to flame, oil and moisture
- Shielding, including braid and foil, is effective for both RFI and EMI noise
- Solid conductor is used for horizontal cabling in fixed applications
- Stranded conductor is designed with flex-life for high mobility applications



## DeviceNet and CANopen

---

- Cables are ODVA compliant and available in thin, mid and thick styles
- PVC jacketing is UL PLTC and CSA listed, flame retardant and sunlight resistant
- TPE jacketing is UL and CSA AWM recognized, oil resistant and excellent cold performance



## PROFIBUS and PROFIBUS-DP

---

- Cables meet the requirements for EN 50170 for communication supporting up to 12 Mbits
- PVC jacketing is UL PLTC listed and rated for exposed run (ER) and direct burial (DB), and it is also suitable for use in Class 1, Div 2 hazardous locations
- Polyurethane jacketing is UL and CSA AWM recognized, oil resistant and excellent cold performance



## PROFIBUS-PA

---

- Cordsets meet the requirements of IEC 61158-2 (ISA/SP-50) and PROFIBUS-PA
- Cables are UL ITC/PLTC and CSA listed, FT4 recognized, rated for Exposed Run (ER) and Direct Burial (DB) and suitable for Class 1, Div 2 hazardous locations
- Jacketing is flame retardant, sunlight resistant and available in armored options



## FOUNDATION Fieldbus

---

- Cordsets meet the requirements of IEC 61158-2 (ISA/SP-50) and FF-844 Type A
- Cables are UL ITC/PLTC and CSA listed, FT4 recognized, rated for Exposed Run (ER) and Direct Burial (DB) and suitable for Class 1, Div 2 hazardous locations
- Jacketing is flame retardant and sunlight resistant



PRODUCT	PAGE
Part number keys	H3
Industrial Ethernet Cordsets including PROFINET	H8
DeviceNet and CANopen	H44
FOUNDATION™ fieldbus	H92
PROFIBUS® -DP/PA	H126
AS-interface®	H164

# NETWORK WIRING

## Network Conduit Adapter Part Number Keys

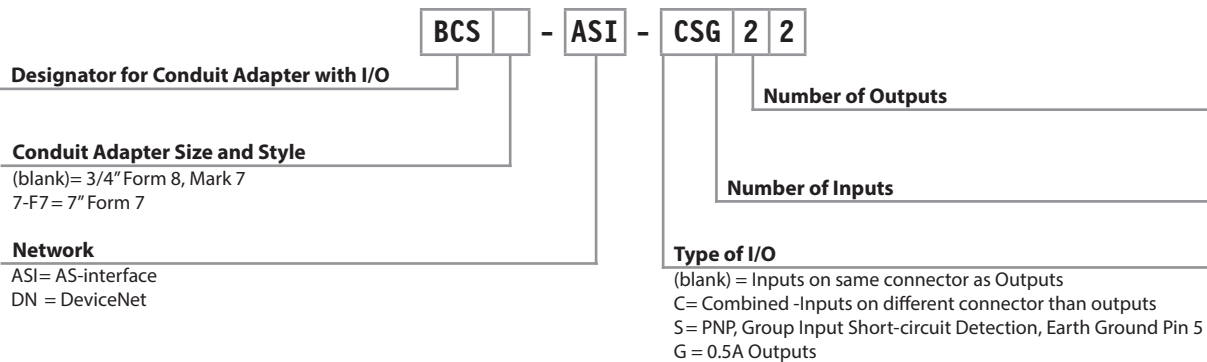
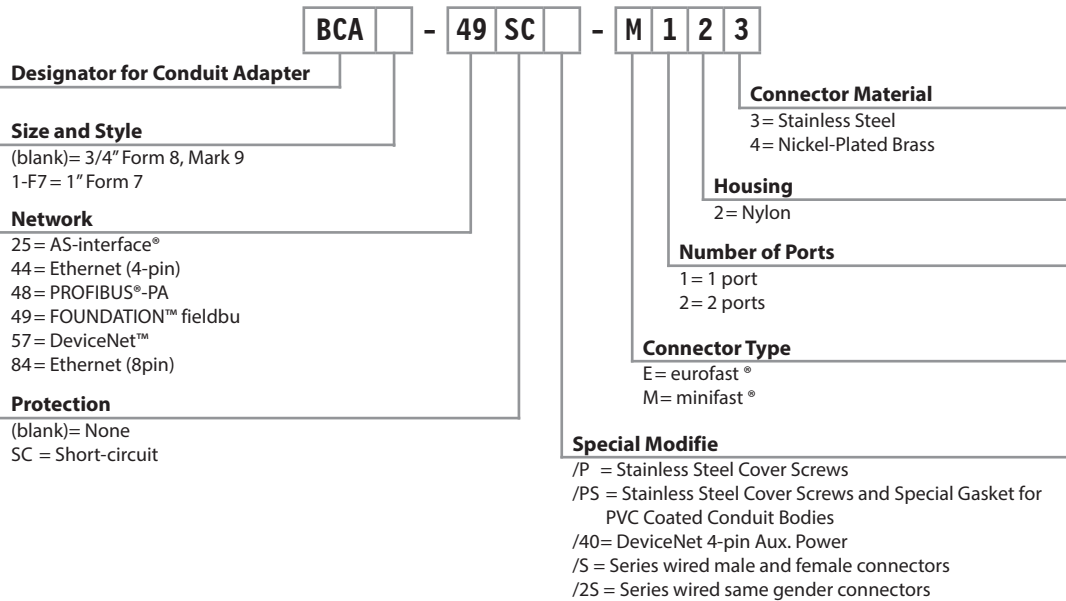

## EtherNet Switches Part Number Key

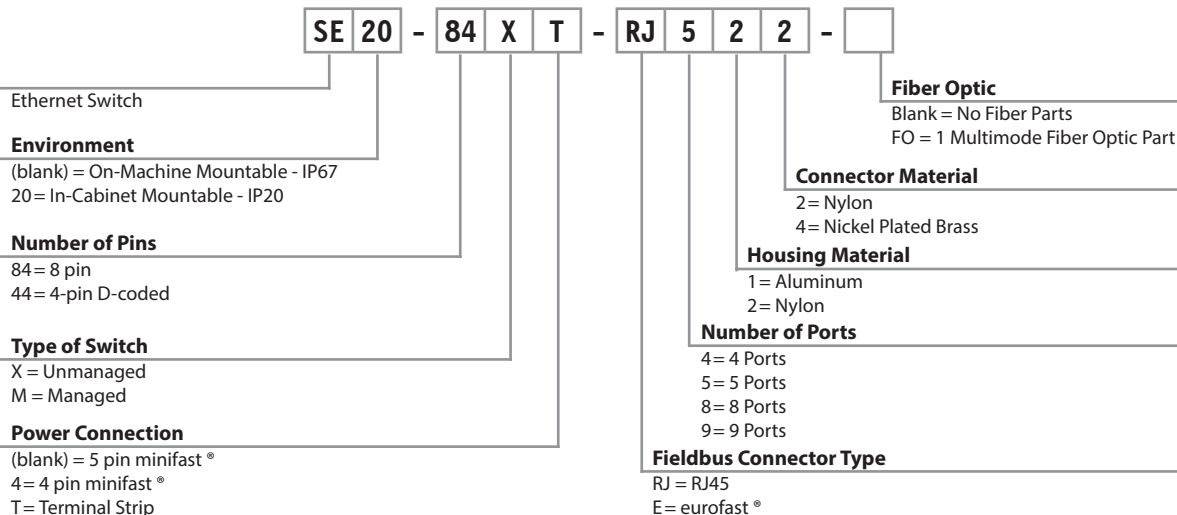

## EtherNet On-Machine Network Junctions Part Number Key

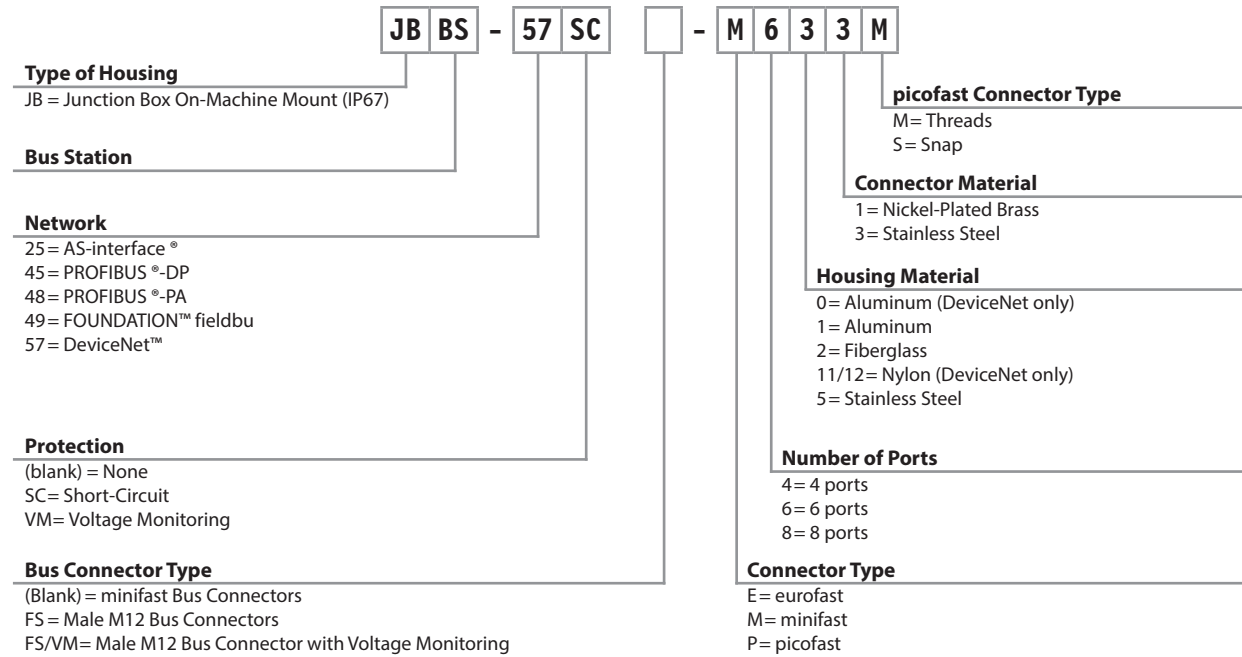

## EtherNet In-Cabinet Network Junction Part Number Key

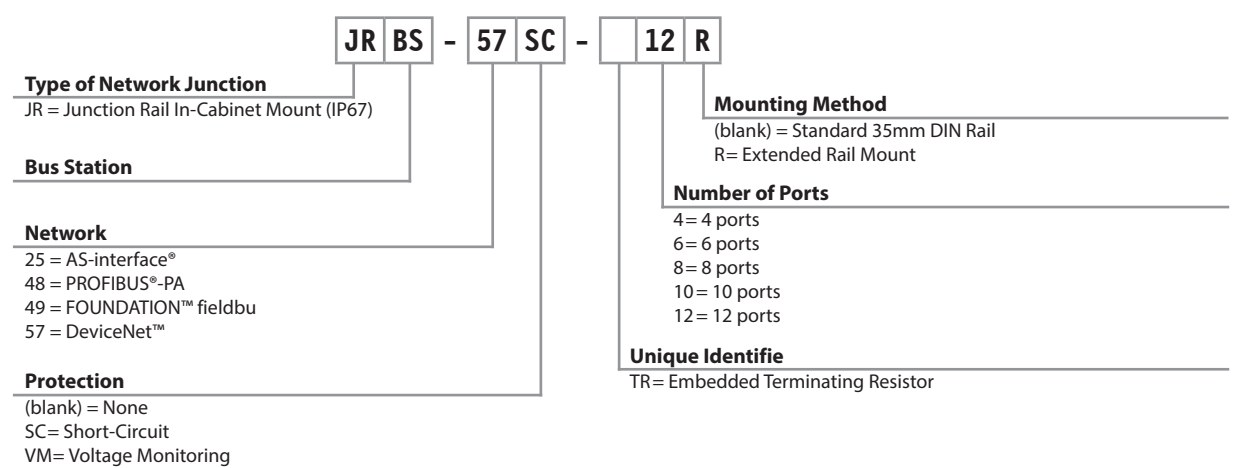

Network Wiring

# NETWORK WIRING

## euromast® Network Cordsets Part Number Key

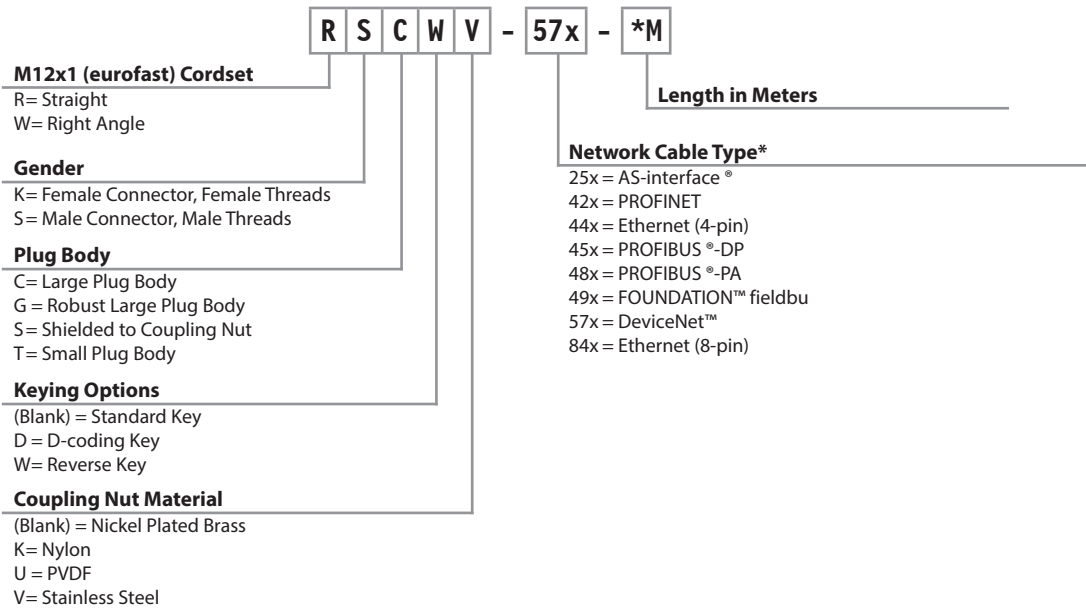

## euromast Network Receptacle Part Number Key

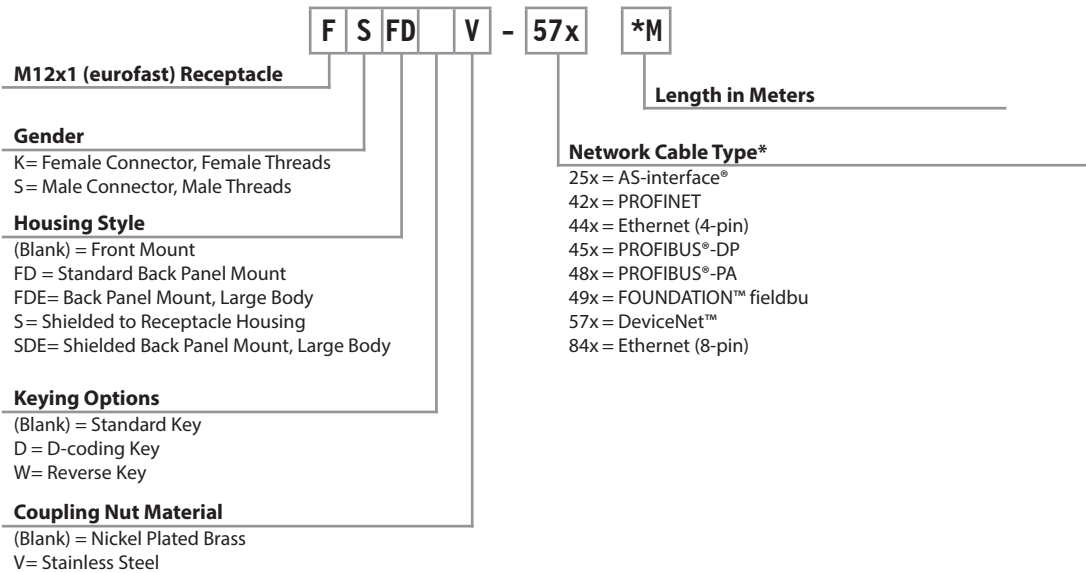

## RJ Network Cordsets Part Number Key

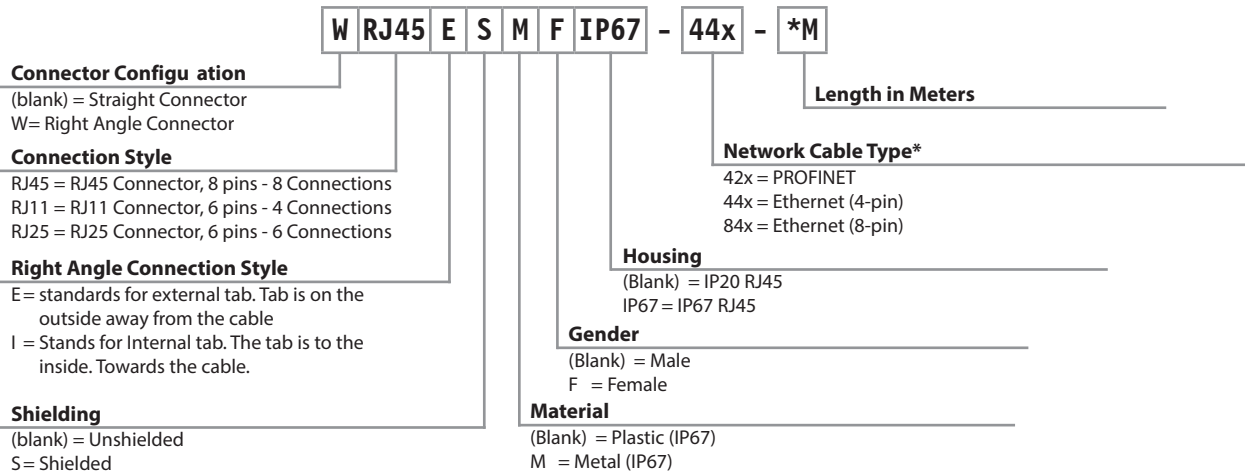

\* See tables for definition and selection of cable types

## minifast® Network Cordsets Part Number Key

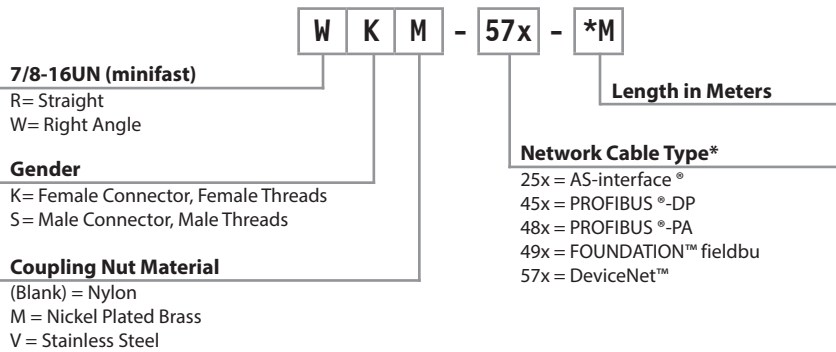

\* See tables for definition and selection of cable types

## minifast Network Receptacle Part Number Key

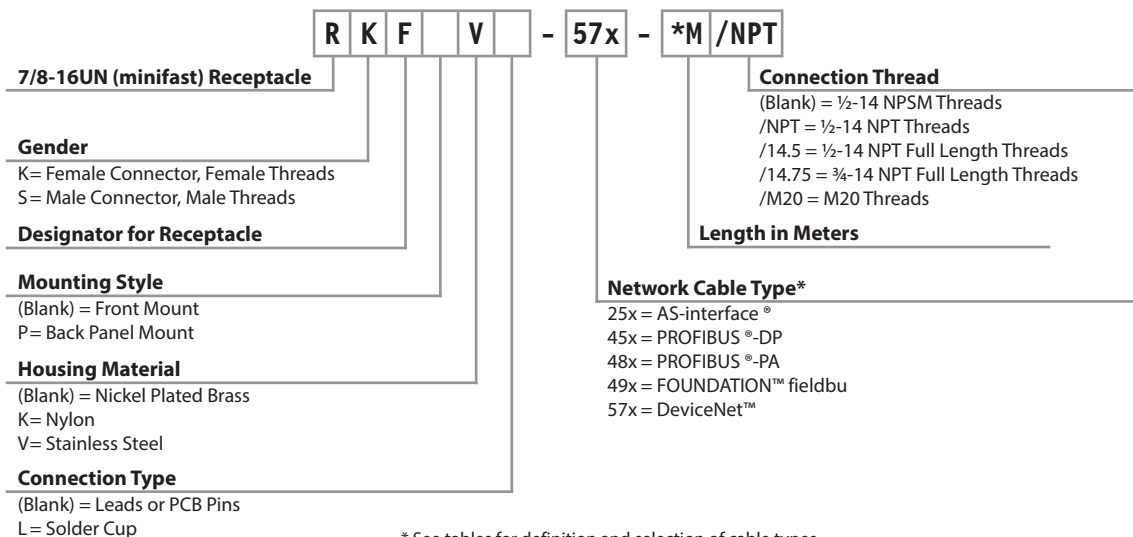

\* See tables for definition and selection of cable types

# NETWORK WIRING

## picofast® Network Cordsets Part Number Key

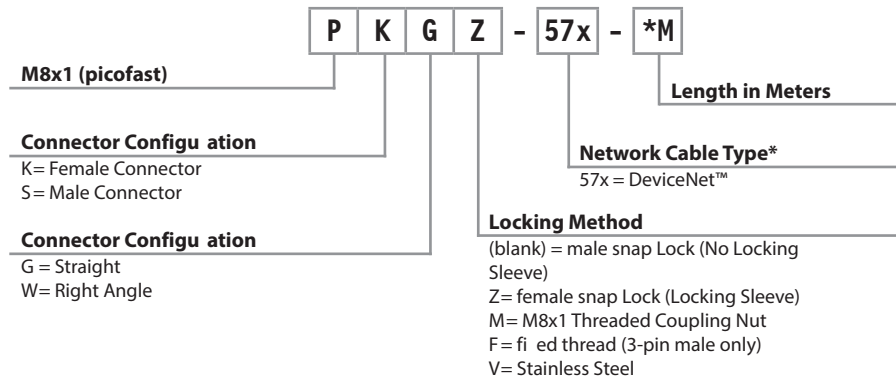

\* See tables for definition and selection of cable types

## picofast Network Receptacle Part Number Key

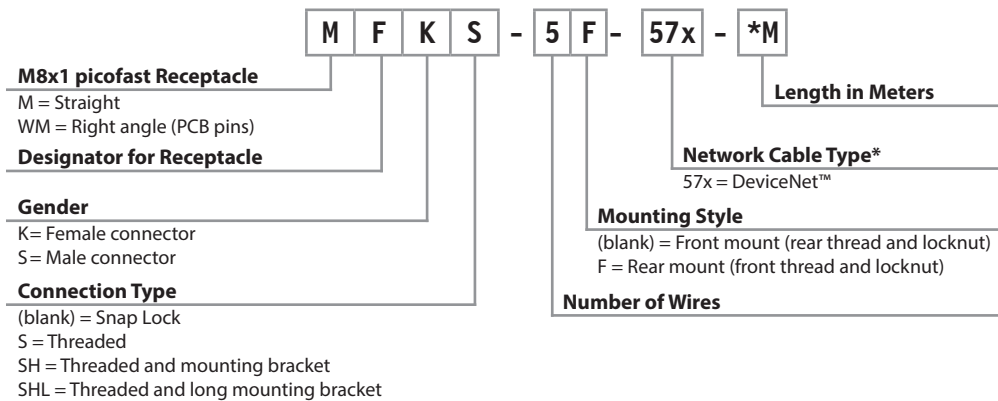

# EtherNet™ Physical Media Connectivity

---

<b>Cordsets (8-pin)</b>	<b>H11</b>
<b>Receptacles</b>	<b>H18</b>
<b>Cordsets (4-pin)</b>	<b>H20</b>
<b>Receptacles</b>	<b>H27</b>
<b>Field Wireables</b>	<b>H28</b>

---

## Features

- CAT 5E rated cables
- 2 pair and 4 pair cable option
- 8-pin and 4-pin D-coded connectors
- M12 and RJ45 connectors
- Up to 4 Amp and 250 Volt rated
- IP67/IP69K rated

# NETWORK WIRING

Notes:

## Ethernet, Cable Specifications, 8-wire

- Cable that Meets the Requirements of TIA/EIA568-C Category 5e Cable for 10 and 100 Base-T Ethernet
- Cable is UL Rated for Sunlight and Oil Resistant
- Weld Splatter Resistant
- Flame Resistant
- CMX - Outdoor-CM listed and AWM 600 V Recognized
- -40°C Low Temp.

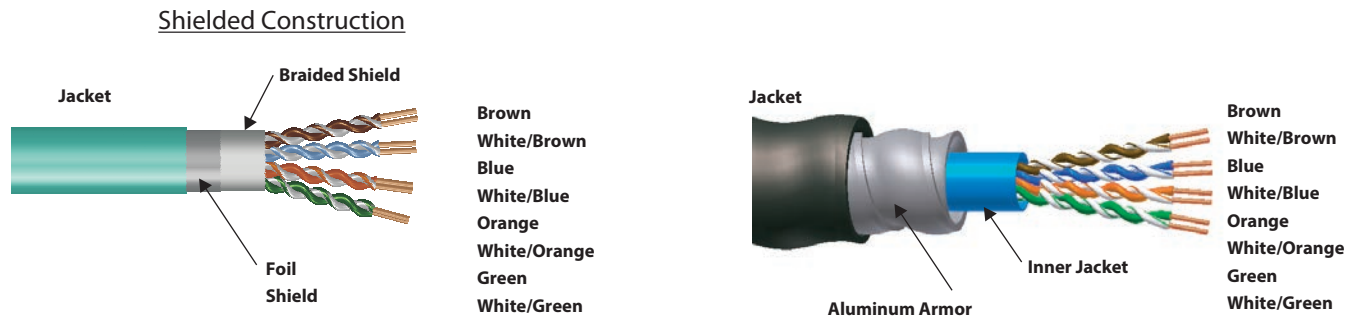

Maximum 100 meters of cable of which:











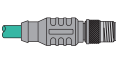

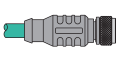

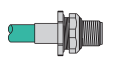
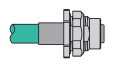
- 90 meters Horizontal Cable (SOLID - 842 or 843)
- 2 x 5 meters Patch Cables (STRANDED - 840 or 841)
- Direct Connect 30 M STRANDED

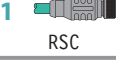
Type	Approvals	Data Pair		Outer Jacket	Shields	Bulk Cable Part Number / Weight/300 M	Flexlife Ratings
		AWG Color Code	DCR (/1000 feet) Insulation	Material Color Nominal O.D.	Type		
<b>840</b> 80°C 600 Volts	NEC CMR (ETL) CEC C (ETL), C(UL)	8/24 AWG Stranded	26 Ohms PE	TPE Teal 6.3 mm (.118 in)	None	RB51460-*M 39 lbs. <i>flexlife</i> <sup>®</sup>	10xO.D. 1 million cycles 20xO.D. 10 million cycles
<b>841</b> 80°C 600 Volts	NEC CMR (ETL) CEC C (ETL), C(UL)	8/24 AWG Stranded	26 Ohms PE	TPE Teal 7.7 mm (.303 in)	Foil/Braid	RB50893-*M 50 lbs. <i>flexlife</i>	10xO.D. 1 million cycles 20xO.D. 10 million cycles
<b>842</b> 75°C 100 Volts	NEC CMR (ETL) CEC C (ETL)	8/24 AWG Solid	28.6 Ohms PE	PVC Teal 6.2 mm (.244 in)	None	RB51462-*M 39 lbs.	None
<b>843</b> 75°C 300 Volts	NEC CMR (ETL) CEC C (ETL)	8/24 AWG Solid	28.6 Ohms PE	PVC Teal 7.3 mm (.287 in)	Foil/Braid	RB51463-*M 50 lbs.	None
<b>849A</b> AWM 444 75°C 300 Volts	NEC CMG IAA CMG, FT4	8/24 AWG Solid	28.6 Ohms PO	PVC Black 14.1 mm (.555 in)	Foil/Braid Armor	RB51100-*M 159 lbs. <i>armorfast</i> <sup>®</sup>	None

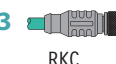
\* Indicates length in meters.  
Standard spool lengths are 30, 75, 100, 150, 200, 225, 300 meters.

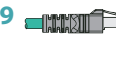
# NETWORK WIRING

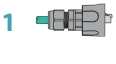
## Ethernet, (M12x1) *eurofast*®, RJ45, Cable/Cordset Selection Matrix - Unshielded

		<i>eurofast</i>						
		Pin (Male)		Socket (Female)		Pin (Male)	Socket (Female)	
		1 	2 	3 	4 	5 	6 	
		RSC	WSC	RKC	WKC	FSFD	FKFD	
		Bare	RSC 84x-*M	WSC 84x-*M	RKC 84x-*M	WKC 84x-*M	FSFD 84x-*M	FKFD 84x-*M
<i>eurofast</i>	Pin (Male)	1 	RSC RSC 84x-*M	RSC WSC 84x-*M	RSC RKC 84x-*M	RSC WKC 84x-*M	RSC FSFD 84x-*M	RSC FKFD 84x-*M
		2 	WSC RSC 84x-*M	WSC WSC 84x-*M	WSC RKC 84x-*M	WSC WKC 84x-*M	WSC FSFD 84x-*M	WSC FKFD 84x-*M
	Socket (Female)	3 			RKC RKC 84x-*M		RKC FSFD 84x-*M	RKC FKFD 84x-*M
		4 			RKC WKC 84x-*M	WKC WKC 84x-*M	WKC FSFD 84x-*M	WKC FKFD 84x-*M
	RJ45 Plug	9 					RJ45 FSFD 84x-*M	RJ45 FKFD 84x-*M
	WRJ45 Plug	10 					WRJ45E FSFD 84x-*M	WRJ45E FKFD 84x-*M
	RJ45M IP67 Plug	11 					RJ45MIP67 FSFD 84x-*M	RJ45MIP67 FKFD 84x-*M
	RJ45 IP67 Plug	12 					RJ45IP67 FSFD 84x-*M	RJ45IP67 FKFD 84x-*M

See pages H15 - H16 for dimensional drawings.

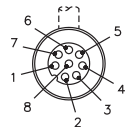
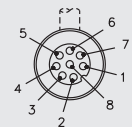
<i>eurofast</i>	Pinouts	<i>eurofast</i>
<b>Male</b> 	1. White/Blue 2. White/Brown 3. Brown 4. Orange 5. White/Green 6. White/Orange 7. Blue 8. Green	<b>Female</b> 

Standard Pinout	RJ45 Plug	(CR) Pinout
1. White/Orange 2. Orange 3. White/Green 4. Blue 5. White/Blue 6. Green 7. White/Brown 8. Brown	<b>Male</b>  <b>12345678</b>	1. White/Green 2. Green 3. White/Orange 4. Blue 5. White/Blue 6. Orange 7. White/Brown 8. Brown

# DISTRIBUTED I/O SALES GUIDE

## Ethernet, (M12x1) *euofast*®, RJ45, Cable/Cordset Selection Matrix - Unshielded



		<i>euofast</i>			
		RJ45 Plug	WRJ45 Plug	RJ45MIP67 Plug	RJ45IP67 Plug
Continued		9  RJ45	10  WRJ45E	11  RJ45MIP67	12  RJ45IP67
Bare		RJ45 84x-*M	WRJ45E 84x-*M	RJ45MIP67 84x-*M	RJ45IP67 84x-*M
<i>euofast</i>	Pin (Male)				
	1  RSC	RSC RJ45 84x-*M	RSC WRJ45E 84x-*M	RSC RJ45MIP67 84x-*M	RSC RJ45IP67 84x-*M
	2  WSC	WSC RJ45 84x-*M	WSC WRJ45E 84x-*M	WSC RJ45MIP67 84x-*M	WSC RJ45IP67 84x-*M
	Socket (Female)				
	2  RKC	RKC RJ45 84x-*M	RKC WRJ45E 84x-*M	RKC RJ45MIP67 84x-*M	RKC RJ45IP67 84x-*M
	4  WKC	WKC RJ45 84x-*M	WKC WRJ45E 84x-*M	WKC RJ45MIP67 84x-*M	WKC RJ45IP67 84x-*M
	RJ45 Plug				
9  RJ45	RJ45 RJ45 84x-*M		RJ45 RJ45MIP67 84x-*M	RJ45 RJ45IP67 84x-*M	
WRJ45 Plug					
10  WRJ45E	WRJ45E RJ45 84x-*M	WRJ45E WRJ45E 84x-*M	WRJ45 RJ45MIP67 84x-*M	WRJ45E RJ45IP67 84x-*M	
RJ45M IP67 Plug					
11  RJ45MIP67			RJ45MIP67 RJ45MIP67 84x-*M	RJ45MIP67 RJ45IP67 84x-*M	
RJ45 IP67 Plug					
12  RJ45IP67			RJ45IP67 RJ45MIP67 84x-*M	RJ45IP67 RJ45IP67 84x-*M	

See pages H15 - H16 for dimensional drawings.

\* Indicates length in meters.

x Indicates cable type.

Standard cable lengths are 1, 2, 4, 6, 8, 10, 15, and in +5 meter increments from there. Consult factory for other lengths.













For stainless steel coupling nuts change part number RSC ... to RSCV, FKFD ... to FKFDV.

For cross-over cable, add "CR" to part number RJ45 RJ45 CR 84x-\*M.



For right angle RJ45, select WRJ45I for internal tab or WRJ45E for external tab.

# NETWORK WIRING

## Ethernet, (M12x1) *euromast*®, RJ45, Cable/Cordset Selection Matrix - Shielded

		<i>euromast</i>						
		Pin (Male)		Socket (Female)		Pin (Male)	Socket (Female)	
		1 	2 	3 	4 	7 	8 	
		RSS	WSS	RKS	WKS	FSSDE	FKSDE	
<i>euromast</i>	Bare	RSS 84x-*M	WSS 84x-*M	RKS 84x-*M	WKS 84x-*M	FSSDE 84x-*M	FKSDE 84x-*M	
	Pin (Male)	1  RSS	RSS RSS 84x-*M	RSS WSS 84x-*M	RSS RKS 84x-*M	RSS WKS 84x-*M	RSS FSSDE 84x-*M	RSS FKSDE 84x-*M
		2  WSS	WSS RSS 84x-*M	WSS WSS 84x-*M	WSS RKS 84x-*M	WSS WKS 84x-*M	WSS FSSDE 84x-*M	WSS FKSDE 84x-*M
		3  RKS			RKS RKS 84x-*M		RKSS FSSDE 84x-*M	RKS FKSDE 84x-*M
		4  WKS			WKS RKS 84x-*M	WKS WKS 84x-*M	WKS FSSDE 84x-*M	WKS FKSDE 84x-*M
		RJ45 Plug					RJ45S FSSDE 84x-*M	RJ45S FKSDE 84x-*M
		9  RJ45S						
	WRJ45 Plug					WRJ45 FSSDE 84x-*M	WRJ45 FKSDE 84x-*M	
	10  WRJ45ES							
	RJ45M IP67 Plug					RJ45SMIP67 FSSDE 84x-*M	RJ45SMIP67 FKSDE 84x-*M	
	11  RJ45SMIP67							

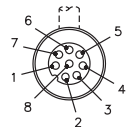



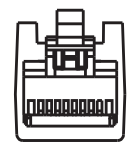





See pages H15 - H16 for dimensional drawings.

<i>euromast</i>	Pinouts	<i>euromast</i>
<p><b>Male</b></p> 	<ol style="list-style-type: none"> <li>1. White/Blue</li> <li>2. White/Brown</li> <li>3. Brown</li> <li>4. Orange</li> <li>5. White/Green</li> <li>6. White/Orange</li> <li>7. Blue</li> <li>8. Green</li> </ol>	<p><b>Female</b></p> 

Standard Pinout	RJ45 Plug	(CR) Pinout
<ol style="list-style-type: none"> <li>1. White/Orange</li> <li>2. Orange</li> <li>3. White/Green</li> <li>4. Blue</li> <li>5. White/Blue</li> <li>6. Green</li> <li>7. White/Brown</li> <li>8. Brown</li> </ol>	<p><b>Male</b></p>  <p><b>12345678</b></p>	<ol style="list-style-type: none"> <li>1. White/Green</li> <li>2. Green</li> <li>3. White/Orange</li> <li>4. Blue</li> <li>5. White/Blue</li> <li>6. Orange</li> <li>7. White/Brown</li> <li>8. Brown</li> </ol>

# DISTRIBUTED I/O SALES GUIDE

## Ethernet, (M12x1) eurofast<sup>®</sup>, RJ45, Cable/Cordset Selection Matrix - Shielded

		RJ45 Plug	WRJ45 Plug	RJ45M IP67 Plug	
		 9 RJ45S	 10 WRJ45ES	 11 RJ45SMIP67	
 Bare		RJ45S 84x-*M	WRJ45ES 84x-*M	RJ45SMIP67 84x-*M	
eurofast	Pin (Male)	 1 RSS	RSS RJ45S 84x-*M	RSS WRJ45ES 84x-*M	RSS RJ45SMIP67 84x-*M
	 2 WSS	WSS RJ45S 84x-*M	WRJ45ES 84x-*M	WSS RJ45SMIP67 84x-*M	
	Socket (Female)	 2 RKS	RKS RJ45S 84x-*M	RKS WRJ45ES 84x-*M	RKS RJ45SMIP67 84x-*M
	 4 WKS	WKS RJ45S 84x-*M	WKS WRJ45ES 84x-*M	WKS RJ45SMIP67 84x-*M	
	RJ45 Plug	 9 RJ45S	RJ45S RJ45S 84x-*M		RJ45SS RJ45SMIP67 84x-*M
	WRJ45 Plug	 10 WRJ45ES	WRJ45ES RJ45S 84x-*M	WRJ45ES WRJ45ES 84x-*M	WRJ45ES RJ45SMIP67 84x-*M
RJ45M IP67 Plug	 11 RJ45SMIP67			RJ45SMIP67 RJ45SMIP67 84x-*M	

See pages H15 - H16 for dimensional drawings.

\* Indicates length in meters.

x Indicates cable type.

Standard cable lengths are 1, 2, 4, 6, 8, 10, 15, and in +5 meter increments from there. Consult factory for other lengths.

For stainless steel coupling nuts change part number RSS ... to RSSV, FKSDE ... to FKSDEV.

For cross-over cable, add "CR" to part number RJ45S RJ45S CR 84x-\*M.

For right angle RJ45, select WRJ45IS for internal tab or WRJ45ES for external tab.

# NETWORK WIRING

## Ethernet, eurofast® Cordset Connector Dimensions / Configuration

### Specifications

**Overmold:** TPU  
**Coupling Nut:** Nickel Plated CuZn or Stainless Steel  
**Contact Carrier:** TPU or POM (Nylon)  
**Contacts:** Gold Plated CuZn  
**Protection:** NEMA 1, 3, 4, 6P and IEC IP 68

**Rated Voltage:** 60 V  
**Rated Current:** 2 A  
**Ambient Temperature:** -40° to +80°C (32° to +176°F)

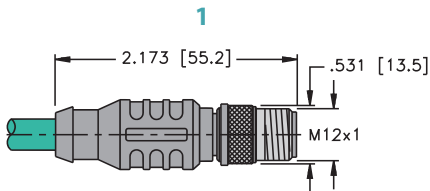

RSC/RSS ..

Pages H11

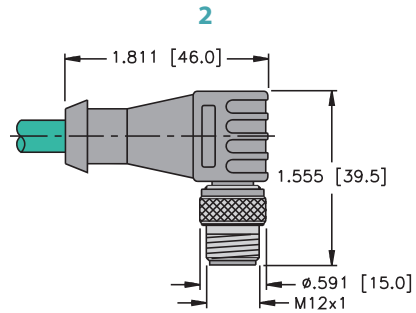

RSC/RSS ..

Pages H11

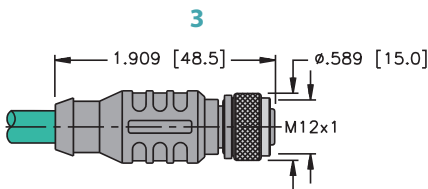

RKC/RKS ..

Pages H11

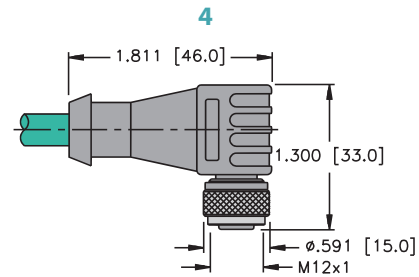

RKC/RKS ..

Pages H11

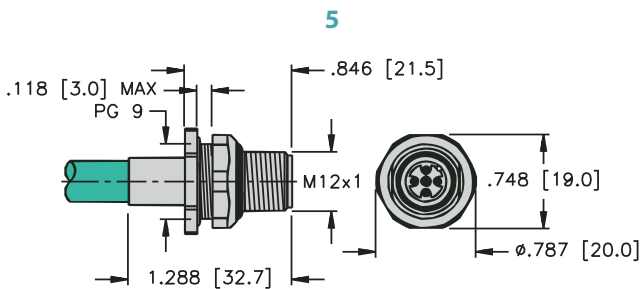

FSFD ..

Pages H11

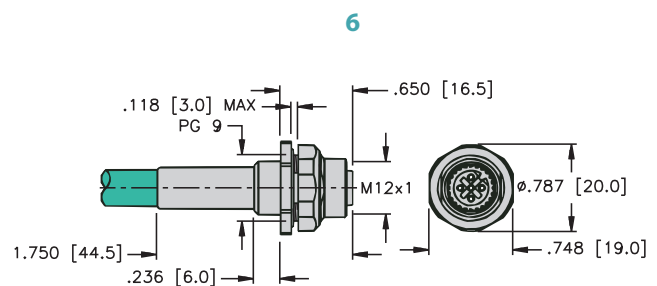

FKFD ..

Pages H11

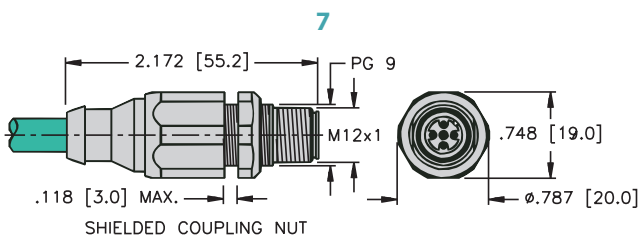

FSSDE ..

Pages H13

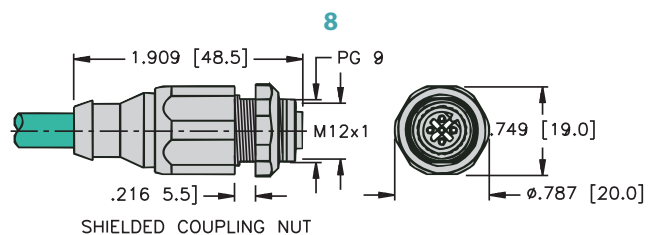

FKSDE ..

Pages H13

# DISTRIBUTED I/O SALES GUIDE

## Ethernet, Armored M12 and RJ45 Connector Dimensions / Configuration



### Specifications

**Overmold:** TPU  
**Coupling Nut:** Nickel Plated CuZn or Stainless Steel  
**Contact Carrier:** TPU or POM (Nylon)  
**Contacts:** Gold Plated CuZn  
**Protection:** NEMA 1, 3, 4, 6P and IEC IP 68

**Rated Voltage:** 60 V  
**Rated Current:** 2 A  
**Ambient Temperature:** -40° to +75°C (-22° to +167°F)

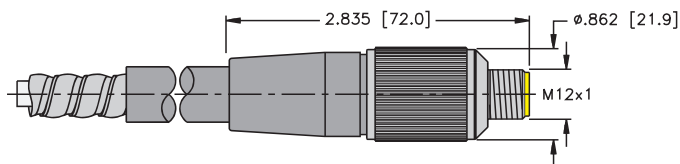

RSA ..

(armorfast® only)

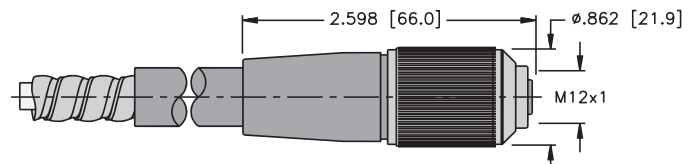

RKA ..

(armorfast only)

### Specifications

**Overmold:** TPU  
**Plug Material:** Polycarbonate  
**Protection:** NEMA 1 and IEC IP 20  
**Rated Voltage:** 42 V  
**Rated Current:** 1.5 A

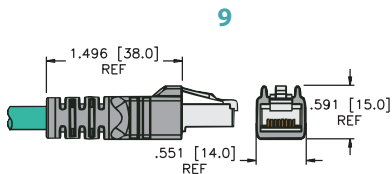

RJ45/RJ45S ..

Page H11

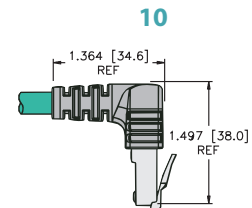

WRJ45E/WRJ45ES ..External tab

Page H11

#### 10 - Internal tab version

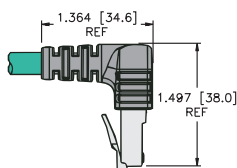

WRJ45I/WRJ45IS .. Internal tab version Page H11

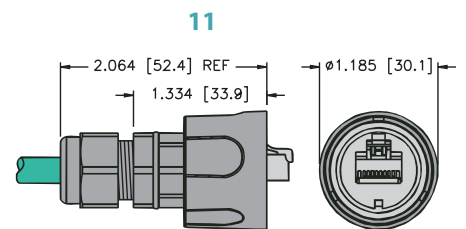

RJ45MIP67/RJ45SMIP67..

Page H11

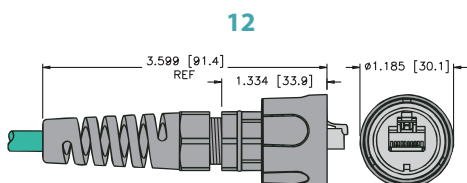

RJ45IP67 ..

Page H11

Ethernet IP Media

# NETWORK WIRING

## Ethernet, Economy RJ45 to RJ45 Cordsets

- For "In the Panel" Applications Where Industrial Cordsets are not Needed
- Available in Yellow, 3 FT and 7 FT Lengths Only



Housing	Part Number	Application	Pinout
	RJ45 RJ45 840-3FT/ECON	<ul style="list-style-type: none"> <li>• Ethernet patch cordsets for panel connections</li> <li>• Economy, non industrial</li> </ul>	<p><b>Male</b></p> <p>12345678</p>
	RJ45 RJ45 840-7FT/ECON		

RJ45 Plug	Pinout
<p><b>Male</b></p> <p>12345678</p>	<ol style="list-style-type: none"> <li>1. White/Orange</li> <li>2. Orange</li> <li>3. White/Green</li> <li>4. Blue</li> <li>5. White/Blue</li> <li>6. Green</li> <li>7. White/Brown</li> <li>8. Brown</li> </ol>

## Ethernet, Circuit Board Connectors and OEM Receptacles, 8-wire

- Provides (M12x1) *eurofast*® 8-Pin Connection to Field Devices



Housing	Female Part Number	Male Part Number	Features	Pinouts
<p><b>FK 84 PCB KIT</b></p> <p><b>FS 84 PCB KIT</b></p>	<b>FK 84-PCB KIT</b>	<b>FS 84-PCB KIT</b>	Nickel plated CuZn or stainless steel, 36 VDC, 1.5 A, -40° to +80°C, <i>eurofast</i> with mounting kit	<p><b>Female</b></p>
<p><b>FK 84 PCB</b></p> <p><b>FS 84 PCB</b></p>	<b>FK 84-PCB</b>	<b>FS 84-PCB</b>	Nickel plated CuZn or stainless steel, 36 VDC, 1.5 A, -40° to +80°C, <i>eurofast</i>	<p><b>Male</b></p>

Standard housing material is nickel plated brass "FSV .."; "FKV .." indicates 316 stainless steel.

For board layout, see website.

**Panel Cutout**  
**FK ... FS**

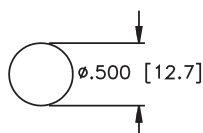

**Panel Cutout**  
**FKFD ... FSFD**

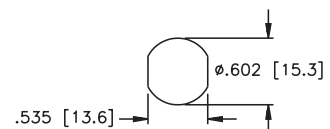

# NETWORK WIRING

## Ethernet, Circuit Board Connectors and OEM Receptacles, 8-wire

- Provides (M12x1) *eurofast*® 8-Pin Connection to Field Devices



Housing	Female Part Number	Male Part Number	Features	Pinouts
<p><b>FKFD..</b></p>	<b>FKFD 84-PCB</b>	<b>FSFD 84-PCB</b>	Nickel plated CuZn or stainless steel 36 VDC, 1.5 A, -40° to +80°C, <b>eurofast</b> PCB pins	<p><b>Male</b></p>
<p><b>FSFD..</b></p>				
<p><b>FKFDL</b></p>	<b>FKFDL 84</b>	<b>FSFDL 84</b>	Nickel plated CuZn or stainless steel 36 VDC, 1.5 A, -40° to +80°C, male <b>eurofast</b> solder cups	<p><b>Female</b></p>
<p><b>FSFDL..</b></p>				
<p><b>WFS..</b></p>		<b>WFS 84-PCB</b>	Nickel plated CuZn or stainless steel 36 VDC, 1.5 A, -40° to +80°C, male <b>eurofast</b> right angle PCB pins	

Standard housing material is nickel plated brass "FKFD.."; "FKFDV.." indicates 316 stainless steel.

For board layout, see website.

**Panel Cutout  
FKFD ... FSFD**

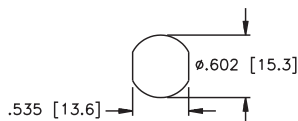

**Panel Cutout  
WFS**

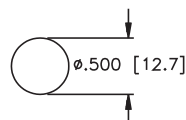

## Ethernet, Cable Specifications, 4-wire

- Cable that Meets the Requirements of TIA/EIA568-C Category 5e Cable for 10 and 100 Base-T Ethernet
- Cable is UL Rated for Sunlight and Oil Resistant
- Weld Splatter Resistant
- Flame Resistant
- CMX - Outdoor-CM listed and AWM 600 V Recognized
- -40°C Low Temp.

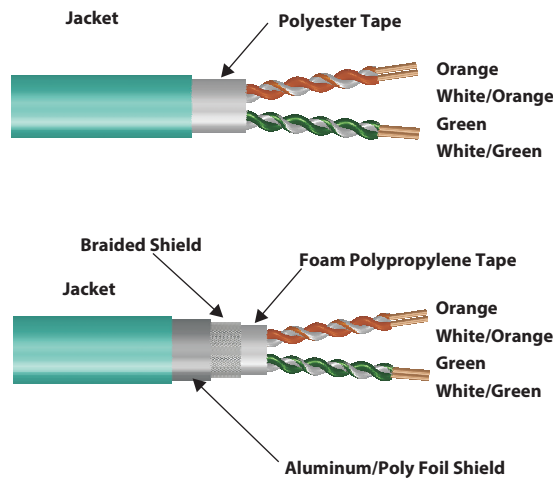

Maximum 100 meters of cable of which:













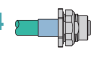

- 90 meters Horizontal Cable (SOLID - 442 or 443)
- 2 x 5 meters Patch Cables (STRANDED - 440 or 441)

Type	Approvals	Data Pair		Outer Jacket	Shields	Bulk Cable Part Number / Weight/300 M	Flexlife Ratings
		AWG Color Code	DCR (/1000 feet) Insulation	Material Color Nominal O.D.	Type		
<b>440</b> 80°C 600 Volts	NEC CMR CEC C(UL) CMR	4/24 AWG Stranded	26 Ohms PO	PVC Teal 6.1 mm (.240 in)	None	RB51210-*M 29 lbs.	10xO.D. 1 million cycles 20xO.D. 10 million cycles
<b>441</b> 80°C 600 Volts	NEC CMR CEC C(UL) CMR	4/24 AWG Stranded	26 Ohms PO	PVC Teal 7.2 mm (.285 in)	Foil/Braid	RB51211-*M 44 lbs.	10xO.D. 1 million cycles 20xO.D. 10 million cycles
<b>442</b> 75°C 300 Volts	NEC CMR CEC C(UL) CMR	4/24 AWG Solid	25.5 Ohms PO	PVC Teal 6.4 mm (.250 in)	None	RB51212-*M 27 lbs.	
<b>443</b> 75°C 300 Volts	NEC CMR CEC C(UL) CMR	4/24 AWG Solid	28.6 Ohms PO	PVC Teal 7.1 mm (.280 in)	Foil/Braid	RB51213-*M 49 lbs.	

\* Indicates length in meters.  
Standard spool lengths are 30, 75, 100, 150, 200, 225, 300 meters.

# NETWORK WIRING

## Ethernet, (M12x1) eurofast®, RJ45 Cables and Extensions - Unshielded D-coded

		eurofast					
		Pin (Male)		Socket (Female)		Pin (Male)	Socket (Female)
		11 	2 	12 	4 	13 	14 
		RSCD	WSCD	RKCD	WKCD	FSFDD	FKFDD
		RSCD 44x-*M	WSCD 44x-*M	RKCD 44x-*M	WKCD 44x-*M	FSFDD 44x-*M	FKFDD 44x-*M
	Bare						
Pin (Male)	11 	RSCD RSCD 44x-*M	RSCD WSCD 44x-*M	RSCD RKCD 44x-*M	RSCD WKCD 44x-*M	RSCD FSFDD 44x-*M	RSCD FKFDD 44x-*M
	2 	WSCD RSCD 44x-*M	WSCD WSCD 44x-*M	WSCD RKCD 44x-*M	WSCD WKCD 44x-*M	WSCD FSFDD 44x-*M	WSCD FKFDD 44x-*M
Socket (Female)	12 			RKCD RKCD 44x-*M		RKCD FSFDD 44x-*M	RKCD FKFDD 44x-*M
	4 			WKCD RKCD 44x-*M	WKCD WKCD 44x-*M	WKCD FSFDD 44x-*M	WKCD FKFDD 44x-*M
RJ45 Plug	17 					RJ45 FSFDD 44x-*M	RJ45 FKFDD 44x-*M
	RJ45						
WRJ45 Plug	18 					WRJ45E FSFDD 44x-*M	WRJ45E FKFDD 44x-*M
	WRJ45E						
RJ45M IP67 Plug	19 					RJ45MIP67 FSFDD 44x-*M	RJ45MIP67 FKFDD 44x-*M
	RJ45MIP67						
RJ45 IP67 Plug	20 					RJ45IP67 FSFDD 44x-*M	RJ45IP67 FKFDD 44x-*M
	RJ45IP67						

See pages H25 - H26 for dimensional drawings.

\* Indicates length in meters.

eurofast	Pinouts	eurofast
Male	<ol style="list-style-type: none"> <li>White/Orange (+ tx)</li> <li>White/Green (+rx)</li> <li>Orange (-tx)</li> <li>Green (-rx)</li> </ol>	Female









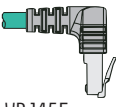

ts from  
FSFD.  
al tab

RJ45 Pinout	RJ45 Plug	RJ45 (CR) Pinout
<ol style="list-style-type: none"> <li>White/Orange</li> <li>Orange</li> <li>White/Green</li> <li>N/C</li> <li>N/C</li> <li>Green</li> <li>N/C</li> <li>N/C</li> </ol>	<p>Male</p>  <p>12345678</p>	<ol style="list-style-type: none"> <li>White/Green</li> <li>Green</li> <li>White/Orange</li> <li>N/C</li> <li>N/C</li> <li>Orange</li> <li>N/C</li> <li>N/C</li> </ol>

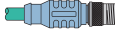
# DISTRIBUTED I/O SALES GUIDE

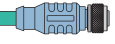
## Ethernet, (M12x1) eurofast®, RJ45, Cables and Extensions - Unshielded D-coded

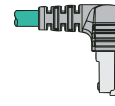

		eurofast			
		Pin (Male)	Socket (Female)	Pin (Male)	Socket (Female)
		<b>17</b>  RJ45	<b>18</b>  WRJ45E	<b>19</b>  RJ45MIP67	<b>20</b>  RJ45IP67
 Bare		RJ45 44x-*M	WRJ45E 44x-*M	RJ45MIP67 44x-*M	RJ45IP67 44x-*M
Pin (Male)	<b>11</b>  RSCD	RSCD RJ45 44x-*M	RSCD WRJ45E 44x-*M	RSCD RJ45MIP67 44x-*M	RSCD RJ45IP67 44x-*M
	<b>2</b>  WSCD	WSCD RJ45 44x-*M	WSCD WRJ45E 44x-*M	WSCD RJ45MIP67 44x-*M	WSCD RJ45IP67 44x-*M
Socket (Female)	<b>12</b>  RKCD	RKCD RJ45 44x-*M	RKCD WRJ45E 44x-*M	RKCD RJ45MIP67 44x-*M	RKCD RJ45IP67 44x-*M
	<b>4</b>  WKCD	WKCD RJ45 44x-*M	WKCD WRJ45E 44x-*M	WKCD RJ45MIP67 44x-*M	WKCD RJ45IP67 44x-*M
eurofast	RJ45 Plug	<b>17</b>  RJ45	RJ45 RJ45 44x-*M	RJ45 RJ45MIP67 44x-*M	RJ45 RJ45IP67 44x-*M
	WRJ45 Plug	<b>18</b>  WRJ45E	WRJ45E RJ45 44x-*M	WRJ45E WRJ45E 44x-*M	WRJ45E RJ45MIP67 44x-*M
	RJ45M IP67 Plug	<b>19</b>  RJ45MIP67		RJ45MIP67 RJ45MIP67 44x-*M	
	RJ45 IP67 Plug	<b>20</b>  RJ45IP67		RJ45IP67 RJ45MIP67 44x-*M	RJ45IP67 RJ45IP67 44x-*M

See pages H25 - H26 for dimensional drawings.

\* Indicates length in meters.











x Indicates cable type.

Standard cable lengths are 1, 2, 4, 6, 8, 10, 15, and in +5 meter increments from there. Consult factory for other lengths.

For right angle RJ45, select WRJ45I for internal tab or WRJ45E for external tab.

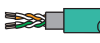
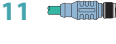
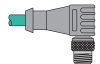
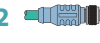
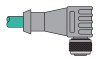
# NETWORK WIRING

## Ethernet, (M12x1) *eurofast*®, RJ45, Cables and Extensions - Shielded Cable D-coded

		<i>eurofast</i>					
		Pin (Male)		Socket (Female)		Pin (Male)	Socket (Female)
		11 	2 	12 	4 	15 	16 
		RSSD	WSSD	RKSD	WKSD	FSSDED	FKSDED
	 Bare	RSSD 44x-*M	WSSD 44x-*M	RKSD 44x-*M	WKSD 44x-*M	FSSDED 44x-*M	FKSDED 44x-*M
<i>eurofast</i>	<b>Pin (Male)</b>						
	11  RSSD	RSSD RSSD 44x-*M	RSSD WSSD 44x-*M	RSSD RKSD 44x-*M	RSSD WKSD 44x-*M	RSSD FSSDED 44x-*M	RSSD FKSDED 44x-*M
	2  WSSD	WSSD RSSD 44x-*M	WSSD WSSD 44x-*M	WSSD RKSD 44x-*M	WSSD WKSD 44x-*M	WSSD FSSDED 44x-*M	WSSD FKSDED 44x-*M
	<b>Socket (Female)</b>						
	12  RKSD			RKSD RKSD 44x-*M		RKSD FSSDED 44x-*M	RKSD FKSDED 44x-*M
	4  WKSD			RKSD WKSD 44x-*M	WKSD WKSD 44x-*M	WKSD FSSDED 44x-*M	RSSD FKSDED 44x-*M
<b>RJ45 Plug</b>							
17  RJ45S						RJ45S FSSDED 44x-*M	RJ45S FKSDED 44x-*M
<b>WRJ45 Plug</b>							
18  WRJ45ES						WRJ45ES FSSDED 44x-*M	WRJ45ES FKSDED 44x-*M
<b>RJ45M IP67 Plug</b>							
19  RJ45SMIP67						RJ45SMIP67 FSFD 84x-*M	RJ45SMIP67 FKFD 84x-*M

See pages H25 - H26 for dimensional drawings.

\* Indicates length in meters.

x Indicates cable type.

Standard cable lengths are 1, 2, 4, 5, 6, 8, 10, 15, and in +5 meter increments from there. Consult factory for other lengths.

For stainless steel coupling nuts change part number RSSD ... RSSD<sub>V</sub>, FSSDED ... FSSDED<sub>V</sub>.

For right angle RJ45, select WRJ45I for internal tab or WRJ45E for external tab.

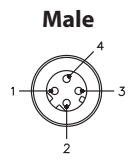
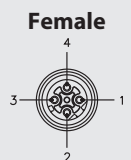

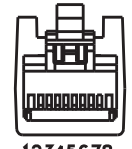



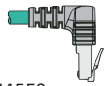

<i>eurofast</i>	Pinouts	<i>eurofast</i>
<b>Male</b> 	1. White/Orange (+ tx) 2. White/Green (+rx) 3. Orange (-tx) 4. Green (-rx)	<b>Female</b> 

RJ45 Pinout	RJ45 Plug	RJ45 (CR) Pinout
1. White/Orange 2. Orange 3. White/Green 4. N/C 5. N/C 6. Green 7. N/C 8. N/C	<b>Male</b>  12345678	1. White/Green 2. Green 3. White/Orange 4. N/C 5. N/C 6. Orange 7. N/C 8. N/C

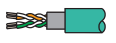
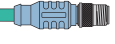
# DISTRIBUTED I/O SALES GUIDE

## Ethernet, (M12x1) eurofast®, RJ45, Cables and Extensions - Shielded Cable D-coded



		eurofast		
		RJ45 Plug	WRJ45 Plug	RJ45 Plug
		<b>17</b>  RJ45S	<b>18</b>  WRJ45ES	<b>19</b>  RJ45SMIP67
		RJ45S 44x-*M	WRJ45ES 44x-*M	RJ45SMIP67 44x-*M
		 Bare		
eurofast	Pin (Male)	<b>11</b>  RSSD	RSSD WRJ45ES 44x-*M	RSSD RJ45SMIP67 44x-*M
		<b>2</b>  WSSD	WSSD WRJ45ES 44x-*M	WSSD RJ45SMIP67 44x-*M
	Socket (Female)	<b>12</b>  RKSD	RKSD WRJ45ES 44x-*M	RKSD RJ45SMIP67 44x-*M
		<b>4</b>  WKSD	WKSD WRJ45ES 44x-*M	WKSD RJ45SMIP67 44x-*M
	RJ45 Plug	<b>17</b>  RJ45S	RJ45S RJ45S 44x-*M	RJ45S RJ45SMIP67 44x-*M
	WRJ45 Plug	<b>18</b>  WRJ45ES	WRJ45ES RJ45S 44x-*M	WRJ45ES RJ45SMIP67 44x-*M
RJ45M IP67 Plug	<b>19</b>  RJ45SMIP67		RJ45SMIP67 RJ45SMIP67 44x-*M	

See pages H25 - H26 for dimensional drawings.

- \* Indicates length in meters.
- x Indicates cable type.

Standard cable lengths are 1, 2, 4, 5, 6, 8, 10, 15, and in +5 meter increments from there. Consult factory for other lengths. For stainless steel coupling nuts change part number RSSD ... RSSDV, FSSDED ... FSSDEDV. For right angle RJ45, select WRJ45I for internal tab or WRJ45E for external tab.

# NETWORK WIRING

## Ethernet, eurofast® Cordset Connector Dimensions / Configuration

### Specifications

<b>Overmold:</b>	TPU
<b>Coupling Nut:</b>	Nickel Plated CuZn or Stainless Steel
<b>Contact Carrier:</b>	TPU or POM (Nylon)
<b>Contacts:</b>	Gold Plated CuZn
<b>Protection:</b>	NEMA 1, 3, 4, 6P and IEC IP 68
<b>Rated Voltage:</b>	125 V-250 V, see individual products for rating
<b>Rated Current:</b>	4 A
<b>Ambient Temperature:</b>	-40° to +80°C (32° to +176°F)

11

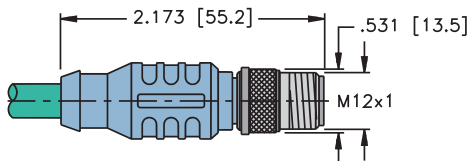

RSCD/RSSD ..

Pages H21

12

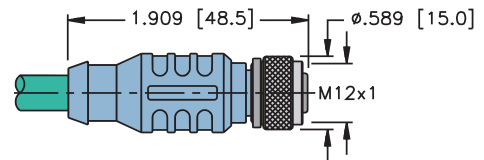

RKCD/RKSD ..

Pages H21

13

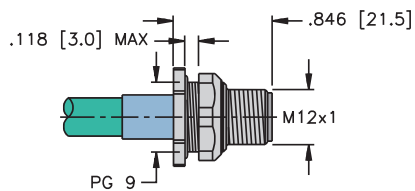

FSFDD ..

Pages H21

14

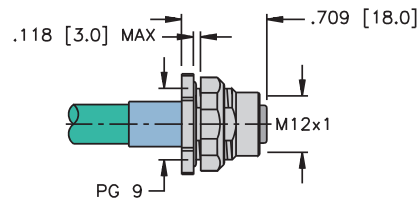

FKFDD ..

Pages H21

15

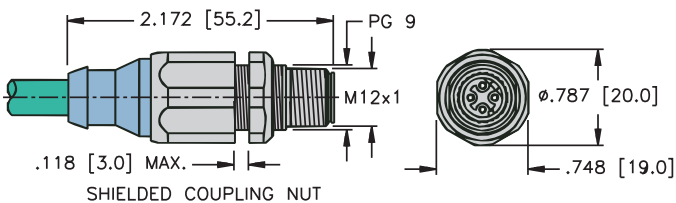

FSSDED ..

Pages H23

16

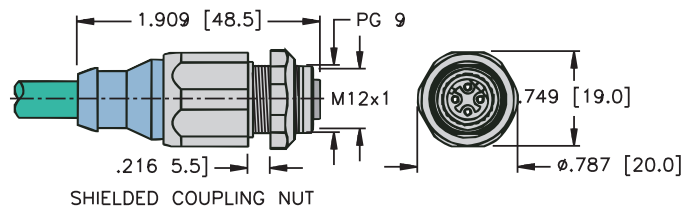

FKSDED ..

Pages H23

### Specifications

<b>Overmold:</b>	TPU
<b>Plug Material:</b>	Polycarbonate
<b>Protection:</b>	NEMA 1, 3, 4, 6P and IEC IP 20
<b>Rated Voltage:</b>	42 V
<b>Rated Current:</b>	1.5 A
<b>Ambient Temperature:</b>	-40° to +80°C (-32° to +176°F)

17

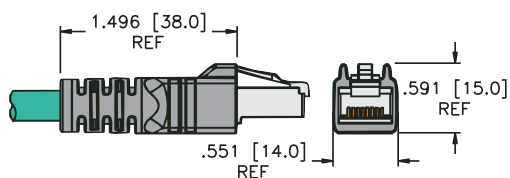

RJ45/RJ45S ..

Page H21

18

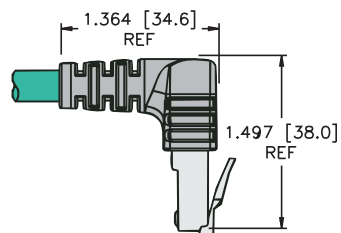

External Tab

WRJ45E/WRJ45ES ..

Page H21

18

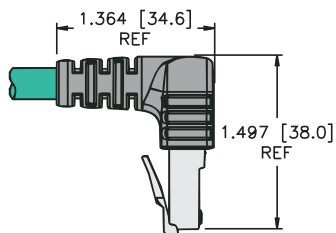

WRJ45I/WRJ45IS ..

Internal tab version

19

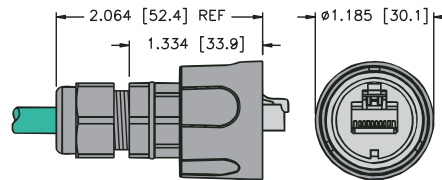

RJ45MIP67/RJ45SMIP67..

Page H21

20

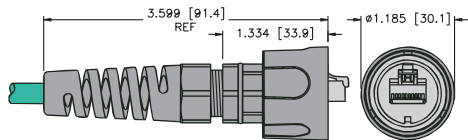

RJ45IP67 ..

Page H21

# NETWORK WIRING

## Ethernet, Receptacle

- Transitions from a RJ45 Connector to a 4-wire *eurofast*® Connector



Housing Style	Part Number	Features
	<b>FKSD RJ45SF 44</b>	Polyurethane, TPU Overmold, 42 V, 1.5 A, -40° to +75°C  See wiring below
	<b>FKSD RJ45SF 44/ST</b>	Polyurethane, TPU Overmold, 42 V, 1.5 A, -40° to +75°C  See wiring below
	<b>FKD FKD 44/M12</b>	4 A, 50V, -25°C to +85°C  See wiring below

Panel mounting clearance hole 19/32" (15 mm). Panel thickness: .060-.120" (1.5-3 mm)

## Wiring Diagram

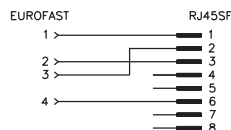

RJ45 Receptacle	Pinouts	<i>eurofast</i> Female
<b>Female</b> 	1. White/Orange (+TX) 2. Orange (-TX) 3. White/Green (+RX) 4. N/C 5. N/C 6. Green (-RX) 7. N/C 8. N/C	<b>Female</b> 

## Ethernet, RJ45 Field Wireable

- Allows for Quick Connections in the Field
- Fully Shielded
- Includes Assembly Instructions



Housing	Part Number	Features	Pinout
	<b>Connector, RJ45S IDC</b>	22-24 AWG stranded, 22-23 AWG solid, -40° to +70°C IP20	<b>Male</b> 
	<b>Connector, FW, RJ45S 84 IDC</b>	22-27 AWG stranded, 22-24 AWG solid, -40° to +85°C, Cat 6	<b>Male</b> 
	<b>Connector, FW, RJ45S 86 IDC CAT 6</b>	22-26 AWG, -40° to +70°C, Cat 6A	<b>Male</b> 

RJ45 Plug	Pinout
<b>Male</b> 	1. White/Orange (+TX) 2. Orange (-TX) 3. White/Green (+RX) 4. N/C 5. N/C 6. Green (-RX) 7. N/C 8. N/C

# NETWORK WIRING

## Ethernet, 4-Pin D-coded Field Wireables

- Allows for Quick Connections when Pre-Molded Cables are not Available
- Available in Male, Straight and Right Angle Connector Configurations



Housing Style	Female Part Number	Male Part Number	Features	Pinouts
<p><b>CMBD 81..</b></p> <p><b>CMBSD 81..</b></p>	CMBD 8141-0/PG9	CMBSD 8141-0/PG9		<p><b>Female</b></p>
<p><b>CMBD 82..</b></p> <p><b>CMBSD 82..</b></p>	CMBD 8241-0/PG9	CMBSD 8241-0/PG9	4 A, 250 V, -40 to +85°C, mates with female 4-pin D-coded eurofast <sup>®</sup> cordsets and receptacles IP67	<p><b>Male</b></p>

# DISTRIBUTED I/O SALES GUIDE



## Ethernet, Conduit Adapters

- Converts Standard Conduits to Quick Disconnect
- Fiberglass Reinforced Nylon Housings
- Stainless Steel Connectors Available
- Gasket and Mounting Screws Provided
- IP67



Housing Style	1-Port Part Number	2-Port Part Number	Specifications	Pinouts
	BCA-44-E124	BCA-44-E224	4-pin D-code Ethernet, Conduit cover for 3/4" Form 8 or Mark 9, -30°C to +80°C (-22°F to +176°F)	
	BCA-84-E124	BCA-84-E224	8-pin Ethernet, Conduit cover for 3/4" Form 8 or Mark 9, -30°C to +80°C (-22°F to +176°F)	
	BCA1-F7-44-E124	BCA1-F7-44-E224	4-pin D-code Ethernet, Conduit cover for 1" Form 7, -30°C to +80°C (-22°F to +176°F)	
	BCA1-F7-84-E124	BCA1-F7-84-E224	8-pin Ethernet, Conduit cover for 1" Form 7, -30°C to +80°C (-22°F to +176°F)	

EtherNet IP Media

# NETWORK WIRING

## Ethernet, Wall Plate Adapters

- Attaches to Standard Single Gang Electrical Box
- Stainless Steel with Stainless Steel Connectors
- Gasket and Mounting Screws Provided
- IP67



Housing Style	4-pin Part Number	8-pin Part Number	Specifications	Pinouts
	BPA-44-E113	BPA-84-E113	IP67 rated, -40°C to +70°C (-40°F to +158°F)	

Housing Style	4-pin Part Number	Specifications	Pinouts
	BIC-44-E424	Can transition to 4- wire euro-fast connector, -30°C to +75°C (-22°F to +167°F)	
	BIC-84-E424	Can transition to 4- wire euro-fast connector, -40°C to +75°C (-40°F to +167°F)	

# DISTRIBUTED I/O SALES GUIDE



## Ethernet, On-Machine Switches

- Fiberglass Reinforced Nylon Housings\*, Fully Potted
- Nickel Plated Brass Connectors\*
- LEDs to Indicate Ethernet Comm Status
- -40°C to +75°C (-40°F to +167°F)
- IP67
- CE

\*(Unless otherwise specified)



Housing Style	4-pin D-code Part Number	8-pin Part Number	Specifications	Pinouts
	SE-44M-E924		9-port, Managed, 5-pin 7/8 x 1 Power	
	SE-44X4-E924	SE-84X4-E924	9-Port, Unmanaged, 4-pin 7/8 x 1 Power	
	SE-44X-E924	SE-84X-E924	9-Port, Unmanaged, 5-pin 7/8 x 1 Power	
		SE-84ST-E924/C1165	9-Port, Unmanaged, Provides RJ45 Connector and power cable on Back for transition to cabinet	
	SE-44X4-E524	SE-84X4-E524	5-Port, Unmanaged, 4-pin 7/8 x 1 Power	
	SE-44X-E524	SE-84X-E524	5-Port, Unmanaged, 5-pin 7/8 x 1 Power	
		SE-84ST-E524/C1165	5-Port, Unmanaged, Provides RJ45 Connector and power cable on Back for transition to cabinet	
		SE-84X-E514/C1157	5-Port, Unmanaged, 5-pin M12 x 1 Power, Machined Aluminum Housing	

EtherNet IP Media

# NETWORK WIRING

## Ethernet, In-Cabinet Switches

- Fiberglass Reinforced Nylon Housings\*
- Nickel Plated Brass Connectors\*
- LEDs to Indicate Ethernet Comm Status
- -40°C to +60°C (-40°F to +140°F)
- IP20
- UL listed
- Class 1, Div 2 Hazardous Locations

\*(Unless otherwise specified)

Housing Style	Part Number	Specifications	Pinouts
	<b>SE20-84X-RJ522</b> <b>SE20-84XT-RJ422-F0</b>	5-Port, Unmanaged 4-Port copper with 1 Multi-mode Fiber Optic port, Unmanaged	 8 7 6 5 4 3 2 1
	<b>SE20-84MT-RJ822</b>	8-Port, Managed, -40°C to +75°C (-40°F to +167°F)	
	<b>SE20-84XT-RJ822</b>	8-port, Unmanaged	

# PROFINET Physical Media Connectivity

---

<b>Cable Specifications</b>	<b>H32</b>
<b>Cordsets</b>	<b>H33</b>
<b>Receptacles</b>	<b>H37</b>
<b>Field Wireables</b>	<b>H38</b>

---

## Features

- CAT 5E rated cables
- 2 Pair cable option
- 4-pin D-coded connectors
- M12 and RJ45 connectors
- Up to 4 Amps and 250 Volt rated
- IP67/IP69K rated

# NETWORK WIRING

Notes:

## PROFINET, Cable Specifications, 4-wire

- Compliant with PROFINET Cable Standards
- Cable is UL Rated for Sunlight and Oil Resistant
- Maximum length of a copper cable PROFINET channel is 100 m

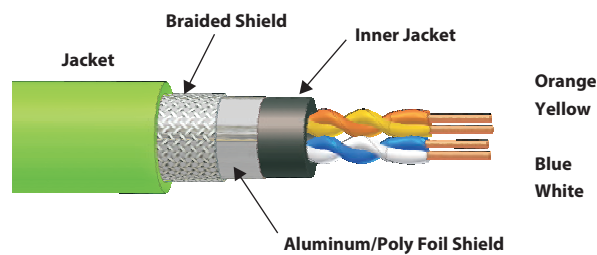

Version	Type	Approvals	Data Pair		Outer Jacket Material Color Nominal O.D.	Shields Type	Bulk Cable Part Number / Weight/300 M
			AWG Color Code	DCR (/1000 feet) Insulation			
Type A Stationary with solid conductors	<b>421</b> 60°C, 300 V	NEC CMR (ETL) CEC C (ETL)	4/22 AWG Solid	16.2 Ohm	PVC Green/Yellow 8.2 mm	Foil/Braid	RB51604*M
Type C Highly flexible with stranded conductors	<b>423</b> 70°C, 600 V	IEC 60332-1 DIN EN 60811-2-1	4/22 AWG Stranded		TPU Green/Yellow 6.5 mm	Foil/Braid	RB51216-*M <i>flexlife</i> †



\* Indicates length

Standard spool lengths are 30, 75, 100, 150, 200, 225, 300 meters. Consult factory for other lengths.

† 3 million flex motions at 7.5x cable diameter bend radius.

# NETWORK WIRING

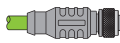
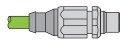
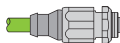
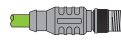
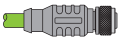
## PROFINET, (M12x1) *eurofast*®, RJ45, Cables and Extensions - Shielded Cable D-coded

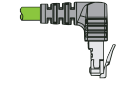
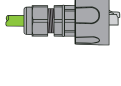
		<i>eurofast</i>			
		Pin (Male)	Socket (Female)	Pin (Male)	Socket (Female)
		1 	2 	3 	4 
		RSSD	RKSD	FSSDED	FKSDED
	Bare	RSSD 42x-*M	RKSD 42x-*M	FSSDED 42x-*M	FKSDED 42x-*M
<i>eurofast</i>	Pin (Male)	1  RSSD RSSD RSSD 42x-*M	RSSD RKSD 42x-*M	RSSD FSSDED 42x-*M	RSSD FKSDED 42x-*M
	Socket (Female)	2  RKSD	RKSD RKSD 42x-*M	RKSD FSSDED 42x-*M	RKSD FKSDED 42x-*M
	RJ45 Plug	5  RJ45S		RJ45S FSSDED 42x-*M	RJ45S FKSDED 42x-*M
	WRJ45 Plug	6  WRJ45ES		WRJ45ES FSSDED 42x-*M	WRJ45ES FKSDED 42x-*M
	RJ45 IP67 Plug	7  RJ45SMIP67		RJ45SMIP67 FSSDED 42x-*M	RJ45SMIP67 FKSDED 42x-*M

See pages H35 - H36 for dimensional drawings.



\* Indicates length in meters.

x Indicates cable type.

Standard cable lengths are 1, 2, 4, 6, 8, 10, 15, and in +5 meter increments from there. Consult factory for other lengths.

For stainless steel coupling nuts change part number RSSD ... RSSDV, FSSDED ... FSSDEDV.

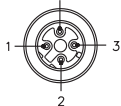
For right angle RJ45, select WRJ45IS for internal tab or WRJ45ES for external tab.



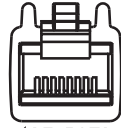



<i>eurofast</i>	Pinouts	<i>eurofast</i>
Male	1. Yellow (+ tx) 2. White (+rx) 3. Orange (-tx) 4. Blue (-rx)	Female
		

RJ45 Pinout	RJ45 Plug	RJ45 (CR) Pinout
1. Yellow 2. Orange 3. White 4. N/C 5. N/C 6. Blue 7. N/C 8. N/C	Male  12345678	1. Yellow 2. Orange 3. White 4. N/C 5. N/C 6. Blue 7. N/C 8. N/C

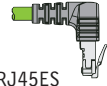
# DISTRIBUTED I/O SALES GUIDE

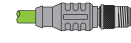
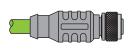

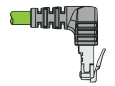
## PROFINET, (M12x1) eurofast®, RJ45, Cables and Extensions - Shielded Cable D-coded



		eurofast		
		RJ45 Plug	WRJ45 Plug	RJ45 IP67 Plug
		<b>5</b>  RJ45S	<b>6</b>  WRJ45ES	<b>7</b>  RJ45SMIP67
 Bare		RJ45S 42x-*M	WRJ45ES 42x-*M	RJ45SMIP67 42x-*M
eurofast	Pin (Male)	<b>1</b>  RSSD RSSD RJ45S 42x-*M	RSSD WRJ45ES 42x-*M	RSSD RJ45SMIP67 42x-*M
	Socket (Female)	<b>2</b>  RKSD RKSD RJ45S 42x-*M	RKSD WRJ45ES 42x-*M	RKSD RJ45SMIP67 42x-*M
	RJ45 Plug	<b>5</b>  RJ45S RJ45S RJ45S 42x-*M		RJ45S RJ45SMIP67 42x-*M
	WRJ45 Plug	<b>6</b>  WRJ45ES WRJ45ES RJ45S 42x-*M	WRJ45ES WRJ45ES 42x-*M	WRJ45ES RJ45SMIP67 42x-*M
		<b>7</b>  RJ45SMIP67 RJ45SMIP67 RJ45S 42x-*M	RJ45SMIP67 WRJ45ES 42x-*M	RJ45SMIP67 RJ45SMIP67 42x-*M

See pages H35 - H36 for dimensional drawings.

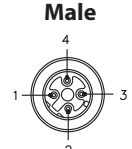
- \* Indicates length in meters.
  - x Indicates cable type.
- Standard cable lengths are 1, 2, 4, 6, 8, 10, 15, and in +5 meter increments from there. Consult factory for other lengths. For stainless steel coupling nuts change part number RSSD ... RSSDV, FSSDED ... FSSDEDV. For right angle RJ45, select WRJ45IS for internal tab or WRJ45ES for external tab.

eurofast	Pinouts	eurofast
<b>Male</b> 	1. Yellow (+ tx) 2. White (+rx) 3. Orange (-tx) 4. Blue (-rx)	<b>Female</b> 

RJ45 Pinout	RJ45 Plug	RJ45 (CR) Pinout
1. Yellow 2. Orange 3. White 4. N/C 5. N/C 6. Blue 7. N/C 8. N/C	<b>Male</b>  12345678	1. Yellow 2. Orange 3. White 4. N/C 5. N/C 6. Blue 7. N/C 8. N/C

# NETWORK WIRING

## PROFINET, eurofast<sup>®</sup> Cordset Connector Dimensions / Configuration

### Specifications

<b>Overmold:</b>	TPU
<b>Coupling Nut:</b>	Nickel Plated CuZn or Stainless Steel
<b>Contact Carrier:</b>	TPU (Polyurethane) or POM (Nylon)
<b>Contacts:</b>	Gold Plated CuZn
<b>Protection:</b>	NEMA 1, 3, 4, 6P and IEC IP 68
<b>Rated Voltage:</b>	250 V
<b>Rated Current:</b>	4 A
<b>Ambient Temperature:</b>	-40° to +70°C (32° to +167°F)

1

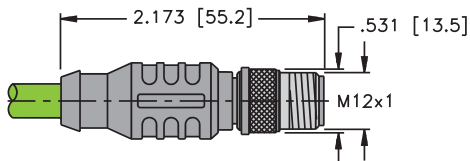

RSCD/RSSD ..

Page H33

2

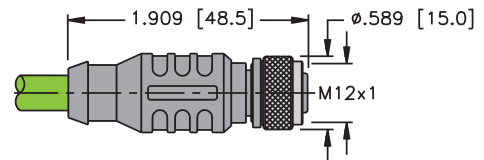

RKCD/RKSD ..

Page H33

3

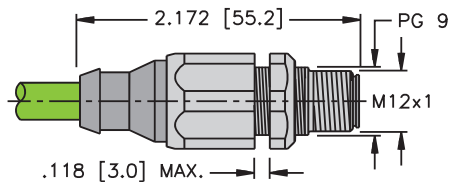

FSSDED ..

Page H33

4

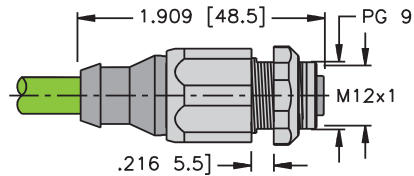

FKSDDED ..

Page H33

### Specifications

<b>Overmold:</b>	TPU
<b>Plug Material:</b>	Polycarbonate
<b>Protection:</b>	NEMA 1, 3, 4, 6P and IEC IP 20
<b>Rated Voltage:</b>	42 V
<b>Rated Current:</b>	1.5 A
<b>Ambient Temperature:</b>	-25° to +70°C (-22° to +176°F)

5

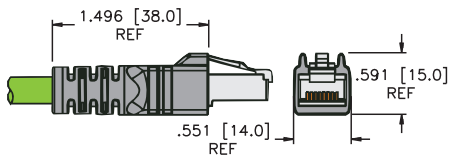

RJ45S ..

Page H33

6

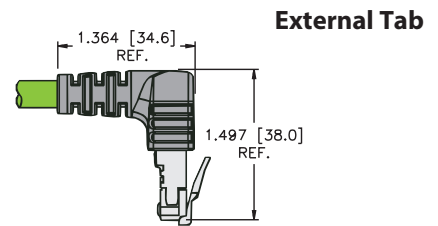

WRJ45ES ..

Page H33

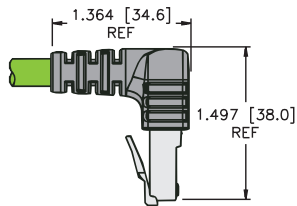

WRJ45IS ..

Internal tab version

7

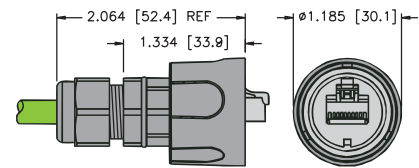

RJ45SMIP67 ..

Page H33

# NETWORK WIRING

## PROFINET, Receptacle

- Transitions from a RJ45 Connector to a 4-wire *eurofast*® Connector



Housing Style	Part Number	Features
	FKSDD RJ45SF 44	Polyurethane, TPU Overmold, 42 V, 1.5 A, -40° to +75°C  See wiring diagram below
	FKSDD RJ45SF 44/ST	Polyurethane, TPU Overmold, 42 V, 1.5 A, -40° to +75°C  See wiring diagram below
	FKD FKD 44/M12	4 A, 50V, -25°C to +85°C

Panel mounting clearance hole 19/32" (15 mm). Panel thickness: .060-.120" (1.5-3 mm)

### Wiring Diagram

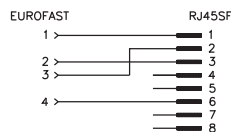



RJ45 Receptacle	Pinouts	<i>eurofast</i> Female
<b>Female</b> 	1. Yellow (+TX) 2. Orange (-TX) 3. White (+RX) 4. N/C 5. N/C 6. Blue (-RX) 7. N/C 8. N/C	<b>Female</b> 

## PROFINET, RJ45 Field Wireable

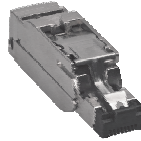
- Allows for Quick Connections in the Field
- Fully Shielded
- Includes Assembly Instructions

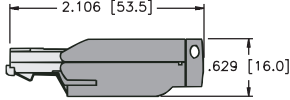

Housing	Part Number	Features	Pinout
	<b>Connector, RJ45S 42 IDC</b>	22-27 AWG stranded, 22-24 AWG solid, -40° to +85°C	<b>Male</b> 

RJ45 Plug	Pinout
<b>Male</b> 	1. Yellow (+TX) 2. Orange (-TX) 3. White (+RX) 4. N/C 5. N/C 6. Blue (-RX) 7. N/C 8. N/C

# NETWORK WIRING

## PROFINET, 4-Pin D-coded Field Wireables

- Allows for Quick Connections when Pre-Molded Cables are not Available



Housing Style	Female Part Number	Male Part Number	Features	Pinouts
<p><b>CMBD 81..</b></p> <p><b>CMBSD 81..</b></p>	CMBD 8141-0/PG9	CMBSD 8141-0/PG9	4 A, 250 V, -40 to +85°C, mates with female 4-pin D-coded eurofast cordsets and receptacles	<p><b>Female</b></p>
<p><b>CMBD 82..</b></p> <p><b>CMBSD 82..</b></p>	CMBD 8241-0/PG9	CMBSD 8241-0/PG9		<p><b>Male</b></p>

# DeviceNet™ Physical Media Connectivity

<b>Cordsets</b>	<b>H49</b>
<b>Splitters &amp; Tees</b>	<b>H65</b>
<b>Receptacles</b>	<b>H76</b>
<b>Field Wireables</b>	<b>H83</b>
<b>Adapters/Junctions</b>	<b>H87</b>

## Features

- Cables that meet the requirements of the ODVA
- PLTC rated cable
- Available in thin, mid, and thick styles
- 7/8 and M12 connectors
- Rated up to 9 Amps and 600 Volts
- IP67/IP69K rated

# NETWORK WIRING

Notes:

## DeviceNet™, Thin Cable Specifications

- Cable that Meets the Requirements of ODVA Thin or Type 1 Cable
- Commonly Used as Drop Cable to a Maximum Length of 6 Meters (20 Feet) or Trunk Cable in Networks Up to a Maximum Length of 100 Meters (328 Feet)

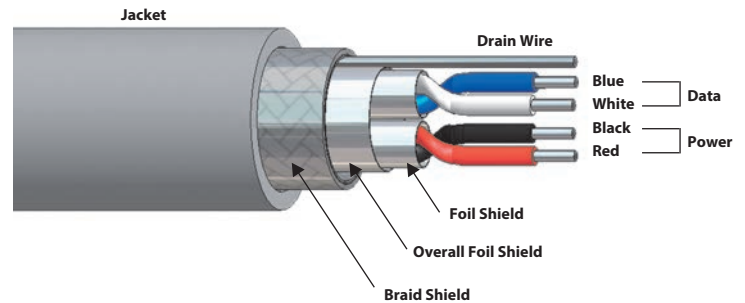

Data Rate	Maximum Trunk Length	Drop Length	
		Maximum	Cumulative
125 Kbaud	100 meters (328 feet)	6 meters (20 feet)	156 meters (512 feet)
250 Kbaud	100 meters (328 feet)		78 meters (feet)
500 Kbaud	100 meters (328 feet)		39 meters (feet)

Type	Approvals	Power Pair		Data Pair		Outer Jacket	Shields	Bulk Cable Part Number / Weight/300 M
		AWG Color Code	DCR (/1000 feet) Insulation	AWG Color Code	DCR (/1000 feet) Insulation			
<b>572</b> PLTC 80°C 300 Volts	NEC PLTC CEC AWM-I/II A/B FT4 RoHS	2/22 AWG BK/RD	18.1 Ohms PVC	2/22 AWG BU/WH	18.1 Ohms PE	PVC Light Grey 7.2 mm (.285 in)	Foil 22 AWG	RB50603-*M 44 lbs.
<b>577</b> PLTC 80°C 300 Volts	NEC PLTC CEC AWM-I/II A/B FT4 RoHS	2/22 AWG BK/RD	17.5 Ohms PVC	2/22 AWG BU/WH	17.5 Ohms PE	PVC Light Grey 8.4 mm (.330 in)	Foil/Braid 22 AWG	RB50629-*M 65 lbs. <b>flexlife®</b>
<b>578</b> PLTC 80°C 600 Volts	NEC PLTC/CL2 CEC CMG RoHS	2/22 AWG BK/RD	18.1 Ohms PVC	2/22 AWG BU/WH	18.1 Ohms PE	PVC Light Grey 7.8 mm (.310 in)	Foil/Braid 22 AWG	RB50651-*M 51 lbs.
<b>5715</b> AWM 2095 80°C 300 Volts	NEC AWM CEC AWM-I/II A/B FT1 RoHS	2/22 AWG BK/RD	18.1 Ohms PVC	2/22 AWG BU/WH	18.1 Ohms PE	PVC Light Grey 6.0 mm (.235 in)	Foil (Data Only) 22 AWG	RB50764-*M 26 lbs.
<b>5725</b> AWM 21080 80°C 300 Volts	NEC AWM RoHS	2/22 AWG BK/RD	16.5 Ohms PE	2/24 AWG BU/WH	27.7 Ohms PE	TPU Violet 7.0 mm (.276 in)	Foil/Braid 22 AWG	RB51916-*M 50 lbs. <b>Halogen-Free ††</b>
<b>5732</b> AWM 20626 80°C 600 Volts	NEC AWM RoHS	2/22 AWG BK/RD	18.1 Ohms PVC	2/22 AWG BU/WH	18.1 Ohms PE	TPE Charcoal Grey 8.5 mm (.335 in)	Foil/Braid 22 AWG	RB51296-*M 68 lbs. <b>Flexlife® weldlife™</b>

\* Indicates length in meters.

Standard spool lengths are 30, 75, 100, 150, 200, 225, 300.

†† Zero Halogen: to DIN VDE 0472 part 815 + IEC 60754-1

# NETWORK WIRING

## DeviceNet™, Mid Cable Specifications

- Cable That Meets the Requirements of ODVA Mid or Type III Cable
- Provides More Flexibility When Used as a Trunk Cable Up to a Maximum Length of 300 Meters (984 Feet)

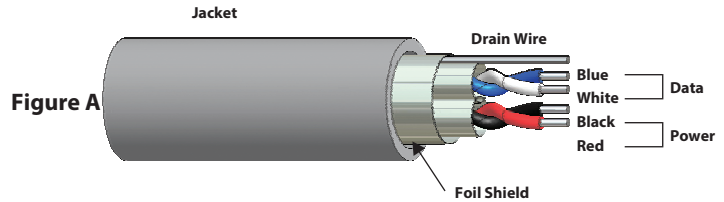

Data Rate	Maximum Trunk Length
125 Kbaud	300 meters (984 feet)
250 Kbaud	250 meters (820 feet)
500 Kbaud	100 meters (328 feet)

Type	Approvals	Power Pair		Data Pair		Outer Jacket	Shields	Bulk Cable Part Number / Weight/300 M	Figure
		AWG Color Code	DCR (/1000 feet) Insulation	AWG Color Code	DCR (/1000 feet) Insulation	Material Color Nominal O.D.	Type Drain Wire		
<b>5711</b> PLTC 80°C 300 Volts	NEC PLTC CEC AWM-I/II A/B FT4 RoHS	2/16 AWG BK/RD	4.1 Ohms PVC	2/20 AWG BU/WH	11.2 Ohms PE	PVC Light Grey 8.4 mm (.330 in)	Foil/Braid 20 AWG	RB50721-*M 65 lbs.	<b>A</b>
<b>5722</b> PLTC 80°C 300 Volts	NEC PLTC CEC AWM-I/II A/B FT4 RoHS	2/17 AWG BK/RD	5.8 Ohms SR-PVC	2/20 AWG BU/WH	11.2 Ohms PE	PVC Light Grey 8.9 mm (.350 in)	Foil/Braid 20 AWG	RB50876-*M 71 lbs. <b>flexlife</b> ®	<b>A</b>
<b>5723</b> AWM 20233 80°C 300 Volts	NEC AWM CEC AWM-I/II A/B FT1 RoHS	2/17 AWG BK/RD	13.6 Ohms PVC	2/20 AWG BU/WH	11.2 Ohms PE	TPU Light Grey 8.4 mm (.330 in)	Foil/Braid 20 AWG	RB50877-*M 60 lbs. <b>flexlife</b>	<b>A</b>
<b>5731</b> AWM 20626 80°C 300 Volts	NEC AWM CEC AWM-I/II A/B FT1 RoHS	2/16 AWG BK/RD	4.1 Ohms PVC	2/20 AWG BU/WH	11.2 Ohms PE	TPE Charcoal Grey 9.6 mm (.254 in)	Foil/Spiral 20 AWG	RB51235-*M 95 lbs. <b>flexlife</b> † <b>weldlife</b> ™	<b>A</b>
<b>5737</b> AWM 20233 80°C 300 Volts	NEC AWM CEC AWM-I/II A/B FT1	2/17 AWG BK/RD	5.8 Ohms PVC	2/20 AWG BU/WH	11.2 Ohms PE	TPU Grey 8.4 mm (.331)	Foil 22 AWG	RB51903-*M 60 lbs. <b>C-Track</b>	<b>A</b>

\* Indicates length in meters.  
Standard spool lengths are 30, 75, 100, 150, 200, 225, 300.

## DeviceNet™, Thick Cable Specifications

- Cable That Meets the Requirements of ODVA Thick or Type II Cable
- It Provides the Most Power to a Network When Used as a Trunk Cable Up to a Maximum Standard Cable Length of 500 Meters (1640 Feet)

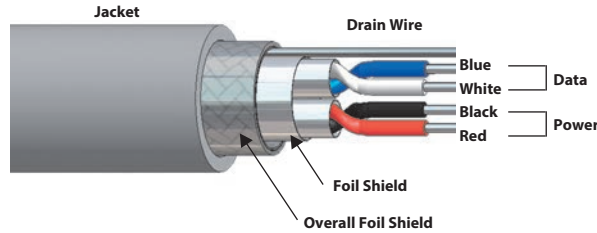

Data Rate	Maximum Trunk Length	Maximum Trunk Length (5720)
125 Kbaud	500 meters (1640 feet)	420 meters (1378 feet)
250 Kbaud	250 meters (820 feet)	200 meters (656 feet)

Type	Approvals	Power Pair		Data Pair		Outer Jacket	Shields	Bulk Cable Part Number / Weight/300 M
		AWG Color Code	DCR (/1000 feet) Insulation	AWG Color Code	DCR (/1000 feet) Insulation			
<b>575</b> AWM 20233 80°C 300 Volts	NEC AWM CEC AWM-I/II A/B FT1 RoHS	2/15 AWG BK/RD	3.6 Ohms PVC	2/18 AWG BU/WH	7.06 Ohms PE	TPU Light Grey 10.4 mm (.409 in)	Foil/Braid 18 AWG	RB50633-*M 94 lbs.
<b>579</b> PLTC 80°C 600 Volts	NEC PLTC/CL2 CEC CMG RoHS	2/15 AWG BK/RD	3.6 Ohms PVC	2/18 AWG BU/WH	7.06 Ohms PE	PVC Light Grey 11.2 mm (.441 in)	Foil/Braid 18 AWG	RB50652-*M 122 lbs.
<b>5720</b> 75°C 600 Volts	NEC TC RoHS	2/16 AWG BK/RD	4.9 Ohms PVC	2/18 AWG BU/WH	6.9 Ohms PE	PVC Light Grey 13.3 mm (.524 in)	Foil/Braid 16 AWG	RB50793-*M 168 lbs.
<b>5727</b> 80°C 600 Volts	NEC PLTC CEC AWM-I/II A/B FT4 RoHS	2/15 AWG BK/RD	3.6 Ohms PVC	2/18 AWG BU/WH	7.06 Ohms PE	PVC Light Grey 12.5 mm (.492 in)	Foil/Spiral 18 AWG	RB51106-*M 157 lbs.
<b>5730</b> AWM 20626 80°C 600 Volts	NEC AWM CEC AWM-I/II A/B FT1 RoHS	2/15 AWG BK/RD	3.6 Ohms PVC	2/18 AWG BU/WH	7.06 Ohms PE	TPE Grey 10.5 mm (.413 in)	Foil/Braid 18 AWG	RB51231-*M 110 lbs. <i>weldlife</i> ™†









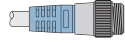

\* Indicates length in meters.

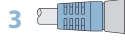
Standard spool lengths are 30, 75, 100, 150, 200, 225, 300.

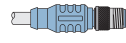
†† Zero Halogen: to DIN VDE 0472 part 815 + IEC 60754-1

# NETWORK WIRING

## DeviceNet™, Cable/Cordset Selection Matrix

		minifast®				eurofast® (Thin/Mid Only)	
		Pin (Male)		Socket (Female)		Pin (Male)	
		1 	2 	3 	4 	7 	
		RSM	WSM	RKM	WKM	RSC	
		RSM 57x-*M	WSM 57x-*M	RKM 57x-*M	WKM 57x-*M	RSC 57x-*M	
Bare							
minifast	Pin (Male)	1 					
		RSM	RSM RSM 57x-*M	RSM WSM 57x-*M	RSM RKM 57x-*M	RSM WKM 57x-*M	RSM RSC 57x-*M
	2 	WSM		WSM WSM 57x-*M	WSM RKM 57x-*M	WSM WKM 57x-*M	WSM RSC 57x-*M
	3 	RKM			RKM RKM 57x-*M	RKM WKM 57x-*M	RKM RSC 57x-*M
4 	WKM				WKM WKM 57x-*M	WKM RSC 57x-*M	



See pages H55 - H56 for dimensional drawings.

\* Indicates length in meters.

x Indicates cable type.

Standard cable lengths are 1, 2, 4, 6, 8, 10, 15, and in +5 meter increments from there. Consult factory for other lengths.

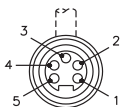
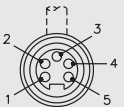
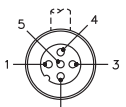

For stainless steel coupling nuts change part number RSM ... to RSV, WSM ... to WSV.

minifast		Pinouts	eurofast	
Male	Female		Male	Female
		1. Bare (Shield Drain Wire) 2. Red (+ Voltage) 3. Black (- Voltage) 4. White (CAN_H) 5. Blue (CAN_L)		

# DISTRIBUTED I/O SALES GUIDE

## DeviceNet™, Cable/Cordset Selection Matrix

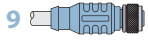
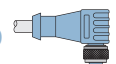
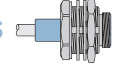
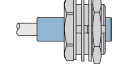

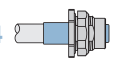
eurofast® (Thin/Mid Only)			minifast® Bulkhead		eurofast Bulkhead (Thin Only)	
Pin (Male)	Socket (Female)	Application	Pin (Male)	Socket (Female)	Pin (Male)	Socket (Female)
8  WSC	9  RKC	10  WKC	5  RSFP	6  RKFP	13  FSFD	14  FKFD
WSC 57x-*M	RKC 57x-*M	WKC 57x-*M	RSFP 57x-*M	RKFP 57x-*M	FSFD 57x-*M	FKFD 57x-*M
RSM WSC 57x-*M	RSM RKC 57x-*M	RSM WKC 57x-*M	RSM RSFP 57x-*M	RSM RKFP 57x-*M	RSM FSFD 57x-*M	RSM FKFD 57x-*M
WSM WSC 57x-*M	WSM RKC 57x-*M	WSM WKC 57x-*M	WSM RSFP 57x-*M	WSM RKFP 57x-*M	WSM FSFD 57x-*M	WSM FKFD 57x-*M
RKM WSC 57x-*M	RKM RKC 57x-*M	RKM WKC 57x-*M	RKM RSFP 57x-*M	RKM RKFP 57x-*M	RKM FSFD 57x-*M	RKM FKFD 57x-*M
WKM WSC 57x-*M	WKM RKC 57x-*M	WKM WKC 57x-*M	WKM RSFP 57x-*M	WKM RKFP 57x-*M	WKM FSFD 57x-*M	WKM FKFD 57x-*M

# NETWORK WIRING

## DeviceNet™, Cable/Cordset Selection Matrix

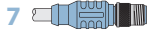
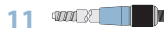
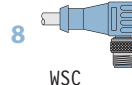
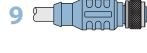
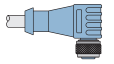
		eurofast® (Thin/Mid Only)				
		Pin (Male)			Socket (Female)	
		 7 RSC	 11 RSA	 8 WSC	 9 RKC	 10 WKC
Bare		RSC 57x-*M	RSA 57x*-M	WSC 57x*-M	RKC 57x-*M	WKC 57x-*M
eurofast (Thin/Mid Only)	Pin (Male)	7 RSC				
		RSC RSC 57x-*M		RSC WSC 57x-*M	RSC RKC 57x-*M	RSC WKC 57x-*M
	11 RSA		RSA RSA 57x-*M			
	8 WSC			WSC WSC 57x-*M	WSC RKC 57x-*M	WSC WKC 57x-*M
	9 RKC				RKC RKC 57x-*M	RKC WKC 57x-*M
Socket (Female)	10 WKC					WKC WKC 57x-*M

See pages H55 - H56 for dimensional drawings.

\* Indicates length in meters.

x Indicates cable type.

Standard cable lengths are 1, 2, 4, 6, 8, 10, 15, and in +5 meter increments from there. Consult factory for other lengths.

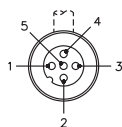
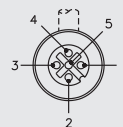

For stainless steel coupling nuts change part number RSC ... to RSCV, WSM ... to WSV.

Pinouts	eurofast	
1. Bare (Shield Drain Wire) 2. Red (+ Voltage) 3. Black (- Voltage) 4. White (CAN_H) 5. Blue (CAN_L)	<b>Male</b> 	<b>Female</b> 

# DISTRIBUTED I/O SALES GUIDE



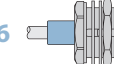

## DeviceNet™, Cable/Cordset Selection Matrix

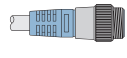

<b>minifast® Bulkhead</b>		<b>eurofast Bulkhead (Thin Only)</b>	
<b>Pin (Male)</b>	<b>Socket (Female)</b>	<b>Pin (Male)</b>	<b>Socket (Female)</b>
<b>5</b>  RSFP	<b>6</b>  RKFP	<b>13</b>  FSFD	<b>14</b>  FKFD
RSFP 57x-*M	RKFP 57x-*M	FSFD 57x-*M	FKFD 57x-*M
RSC RSFP 57x-*M	RSC RKFP 57x-*M	RSC FSFD 57x-*M	RSC FKFD 57x-*M
WSC RSFP 57x-*M	WSC RKFP 57x-*M	WSC FSFD 57x-*M	WSC FKFD 57x-*M
RKC RSFP 57x-*M	RKC RKFP 57x-*M	RKC FSFD 57x-*M	RKC FKFD 57x-*M
WKC RSFP 57x-*M	WKC RKFP 57x-*M	WKC FSFD 57x-*M	WKC FKFD 57x-*M

# NETWORK WIRING

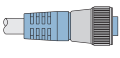
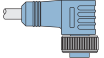
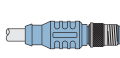
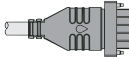
## DeviceNet™, Open Connector Cordset Selection Matrix

		<i>minifast</i> <sup>*</sup>				<i>eurofast</i> <sup>*</sup>
		Pin (Male)		Socket (Female)		Pin (Male)
		1 	2 	3 	4 	7 
		RSM	WSM	RKM	WKM	RSC
<b>15</b>  CBC5	CBC5 57x-*M	RSM CBC5 57x-*M	WSM CBC5 57x-*M	RKM CBC5 57x-*M	WKM CBC5 57x-*M	RSC CBC5 57x-*M
<b>16</b>  BK52C	BK52C 57x-*M	RSM BK52C 57x-*M	WSM BK52C 57x-*M	RKM BK52C 57x-*M	WKM BK52C 57x-*M	RSC BK52C 57x-*M
Thin, Mid and Thick Cable						Thin Cable Only

See pages H54 - H56 for dimensional drawings.

\* Indicates length in meters.

x Indicates cable type.

Standard cable lengths are 1, 2, 4, 6, 8, 10, 15, and in +5 meter increments from there. Consult factory for other lengths.

For stainless steel coupling nut: Change part number (RSM ... to RSV, RSC ... to RSCV).

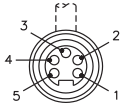
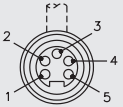
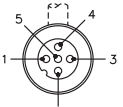
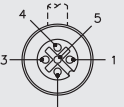
<i>minifast</i>		Pinouts	<i>eurofast</i>	
<b>Male</b> 	<b>Female</b> 	<ol style="list-style-type: none"> <li>1. Bare (Shield Drain Wire)</li> <li>2. Red (+ Voltage)</li> <li>3. Black (- Voltage)</li> <li>4. White (CAN_H)</li> <li>5. Blue (CAN_L)</li> </ol>	<b>Male</b> 	<b>Female</b> 

# DISTRIBUTED I/O SALES GUIDE

## DeviceNet™, Open Connector Cordset Selection Matrix

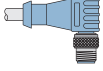
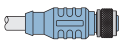
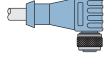
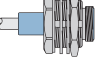
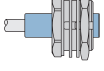
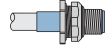
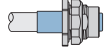

eurofast®			minifast® Bulkhead		eurofast Bulkhead	
Pin (Male)	Socket (Female)		Pin (Male)	Socket (Female)	Pin (Male)	Socket (Female)
8 	9 	10 	5 	6 	13 	14 
WSC	RKC	WKC	RSFP	RKFP	FSFD	FKFD
WSC CBC5 57x-*M	RKC CBC5 57x-*M	WKC CBC5 57x-*M	RSFP CBC5 57x-*M	RKFP CBC5 57x-*M	FSFD CBC5 57x-*M	FKFD CBC5 57x-*M
WSC BK52C 57x-*M	RKC BK52C 57x-*M	WKC BK52C 57x-*M	RSFP BK52C 57x-*M	RKFP BK52C 57x-*M	FSFD BK52C 57x-*M	FKFD BK52C 57x-*M
Thin and Mid Cable Only			Thin, Mid and Thick Cable		Thin Cable Only	

See pages H55 - H56 for dimensional drawings.

\* Indicates length in meters.

x Indicates cable type.

Standard cable lengths are 1, 2, 4, 6, 8, 10, 15, and in +5 meter increments from there. Consult factory for other lengths.

### Specifications

- Overmold:** TPU
- Contact Carrier:** PA (Nylon)
- Protection:** NEMA 1, and IEC IP 20
- Rated Voltage:** 250 V
- Rated Current:** 12 A
- Ambient Temperature:** -40° to +75°C (-22° to +167°F)

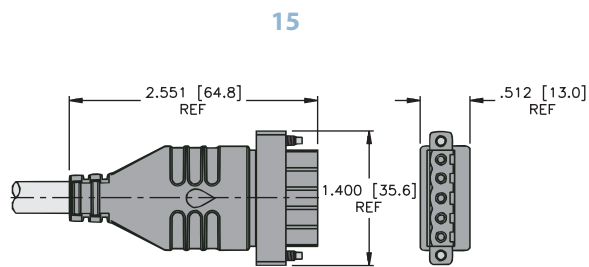

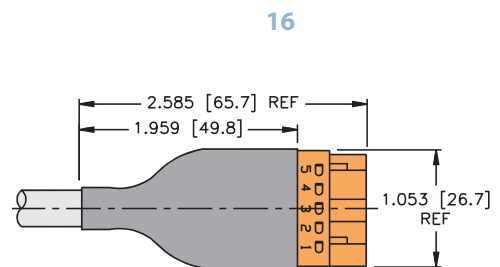

CBC5 ..

Page H53

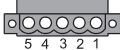

BK52C ..

Page H53

CBC5	Pinouts	BK52C
	1 = Black (- Voltage) 2 = Blue (CAN_L) 3 = Bare (Shield Drain) 4 = White (CAN_H) 5 = Red (+ Voltage)	

# NETWORK WIRING

## DeviceNet™, minifast® Cordset and Receptacle Connector Dimensions

### Specifications

<b>Overmold:</b>	TPU
<b>Coupling Nut:</b>	Nickel Plated CuZn or Stainless Steel
<b>Contact Carrier:</b>	TPU
<b>Contacts:</b>	Gold Plated CuZn
<b>Protection:</b>	NEMA 1, 3, 4, 6P and IEC IP 67
<b>Rated Voltage:</b>	300 V
<b>Ambient Temperature:</b>	-40° to +75°C (-22° to +167°F)

1

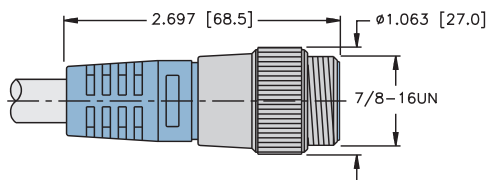

RSM ..

Pages H49 - H54

2

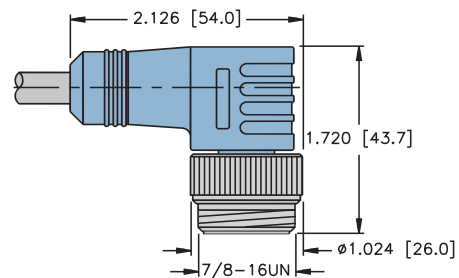

WSM ..

Pages H49 - H54

3

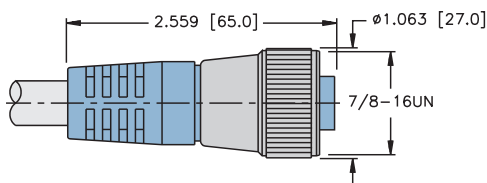

RKM ..

Pages H49 - H54

4

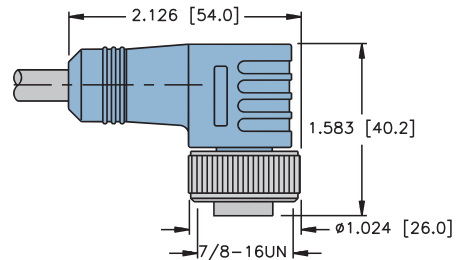

WKM ..

Pages H49 - H54

5

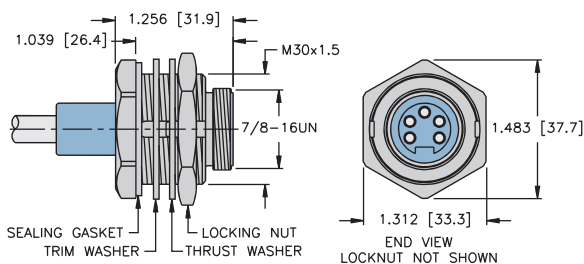

RSFP ..

Pages H49 - H54

6

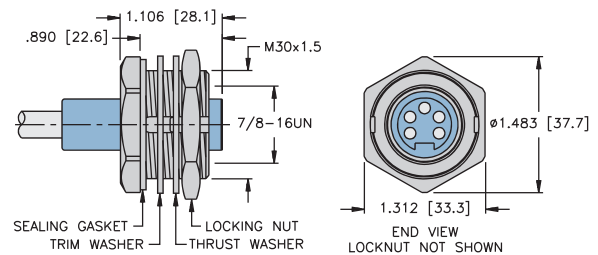

RKFP ..

Pages H49 - H54

# DISTRIBUTED I/O SALES GUIDE

## DeviceNet™, eurofast® Cordset and Receptacle Connector Dimensions



### Specifications

<b>Overmold:</b>	TPU
<b>Coupling Nut:</b>	Nickel Plated CuZn or Stainless Steel
<b>Contact Carrier:</b>	TPU or POM (Nylon)
<b>Contacts:</b>	Gold Plated CuZn
<b>Protection:</b>	NEMA 1, 3, 4, 6P and IEC IP 68
<b>Rated Voltage:</b>	250 V
<b>Rated Current:</b>	4 A
<b>Ambient Temperature:</b>	-40° to +75°C (-22° to +167°F)

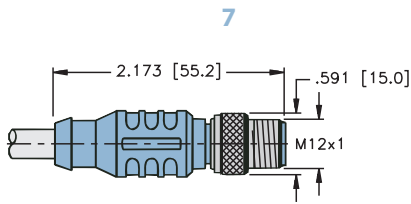

RSC ..

Pages H49 - H54

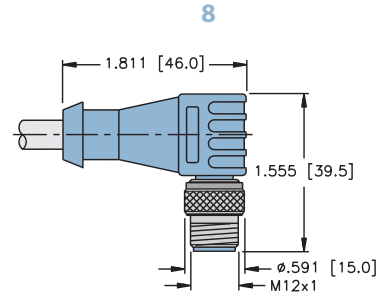

WSC ..

Pages H49 - H54

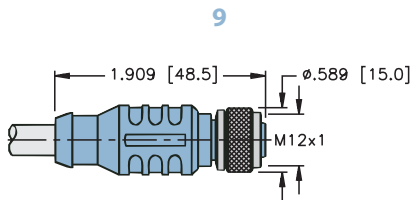

RKC ..

Pages H49 - H54

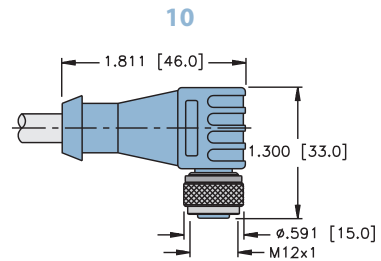

WKC ..

Pages H49 - H54

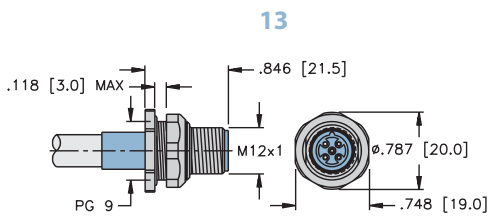

FSFD ..

Pages H49 - H54

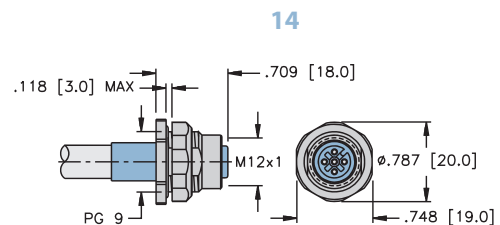

FKFD ..

Pages H49 - H54

# NETWORK WIRING

## DeviceNet™, Pico Cable Specifications

- Cable that Meets the Electrical Requirements of ODVA Thin Cable
- Pico Cable has 24 AWG Conductors Which May be Used with *picofast*® Connectors

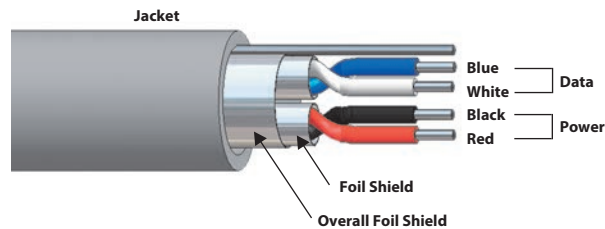

### DeviceNet - Pico Cable 5724

Data Rate	Maximum Trunk Length
125 Kbaud	35 meters (115 feet)
250 Kbaud	35 meters (115 feet)
500 Kbaud	35 meters (115 feet)

### DeviceNet - Thin Cable 5715

Data Rate	Maximum Trunk Length
125 Kbaud	100 meters (984 feet)
250 Kbaud	100 meters (820 feet)
500 Kbaud	100 meters (328 feet)

Type	Approvals	Power Pair		Data Pair		Outer Jacket	Shields	Bulk Cable Part Number / Weight/300 M
		AWG Color Code	DCR (/1000 feet) Insulation	AWG Color Code	DCR (/1000 feet) Insulation			
<b>5724</b> AWM 2464 80°C 300 Volts	<b>NEC</b> AWM <b>CEC</b> AWM-I/II A/B FT1 <b>RoHS</b>	2/24 AWG BK/RD	24.9 PVC	2/24 AWG BU/WH	24.9 PE	PVC Light Grey 5.7 mm (.224 in)	Foil (Data Only) 24 AWG	RB51045-*M 27 lbs.
<b>5715</b> AWM 2464 80°C 300 Volts	<b>NEC</b> AWM <b>CEC</b> AWM-I/II A/B FT1 <b>RoHS</b>	2/22 AWG BK/RD	16.5 PVC	2/22 AWG BU/WH	16.5 PE	PVC Light Grey 6.0 mm (.235 in)	Foil (Data Only) 22 AWG	RB50764-*M 26 lbs.

\* Indicates length in meters.

Standard cable lengths are 1, 2, 4, 6, 8, 10, 15, and in +5 meter increments from there. Consult factory for other lengths.

# DISTRIBUTED I/O SALES GUIDE

## DeviceNet™, Cable/Cordsets Selection Matrix - Threaded



		picofast (M8)				eurofast (M12)			
		Socket (Female)		Pin (Male)		Pin (Male)	Pin (Male)	Socket (Female)	Socket (Female)
		3	4	1	2	7	8	9	10
		PKG 5M	PKW 5M	PSG 5M	PSW 5M	RST	WST	RKT	WKT
		PKG 5M-57x	PKW 5M-57x	PSG 5M-57x	PSW 5M-57x	RST 57x*	WST 57x	RKT 57x-*	WKT 57x-*
Socket (Female)	3	PKG 5M PKG 5M-57x	PKG 5M PKW 5M-57x	PKG 5M PSG 5M-57x	PKG 5M PSW 5M-57x	PKG 5M RST 57x*M	PKG 5M WST 57x*M	PKG 5M RKT 57x*M	PKG 5M WKT 57x*M
	4		PKW 5M PKW 5M-57x	PKW 5M PSG 5M-57x	PKW 5M PSW 5M-57x	PKW 5M RST 57x*M	PKW 5M WST 57x*M	PKW 5M RKT 57x*M	PKW 5M WKT 57x*M
Pin (Male)	1			PSG 5M PSG 5M-57x	PSG 5M PSW 5M-57x	PSG 5M RST 57x*M	PSG 5M WST 57x*M	PSG 5M RKT 57x*M	PSG 5M WKT 57x*M
	2				PSW 5M PSW 5M-57x	PSW 5M RST 57x*M	PSW 5M WST 57x*M	PSW 5M RKT 57x*M	PSW 5M WKT 57x*M

See pages H60 - H61 for dimensional drawings.

\* Indicates length in meters.

x Indicates cable type. See page B125 for available cable types.



Standard cable lengths are 1, 2, 6, 8, 10, 15, and in +5 meter increments from there. Consult factory for other lengths.

For stainless steel coupling nuts change part number PSG 5M ... to PSGV 5M, PSW 5M ... to PSWV 5M.

picofast		Pinouts	eurofast	
<b>Male</b> 	<b>Female</b> 	1. Bare (Shield Drain Wire) 2. Red (+ Voltage) 3. Black (- Voltage) 4. White (CAN_H) 5. Blue (CAN_L)	<b>Male</b> 	<b>Female</b> 

# NETWORK WIRING

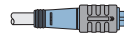
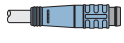
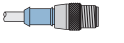
## DeviceNet™, Cable/Cordsets Selection Matrix - Snap Lock

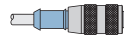
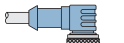
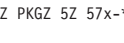
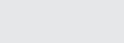

		picofast <sup>®</sup>		eurofast <sup>®</sup>			
		Socket (Female)	Pin (Male)	Pin (Male)	Pin (Male)	Socket (Female)	Socket (Female)
		<b>6</b>  PKG 5Z	<b>5</b>  PSG 5	<b>7</b>  RST	<b>8</b>  WST	<b>9</b>  RKT	<b>10</b>  WKT
Bare		PKG 5Z 57x-*M	PSG 5 57x-*M	RST 57x-*	WST 57x-*	RKT 57x-*	WKT 57x-*
picofast <sup>®</sup> (5724 Cable Only)	Socket (Female)	<b>6</b>  PKG 5Z PKGZ 5Z 57x-*M	PKG 5Z PSG 57x-*M	PKG 5Z RST 57x-*M	PKG 5Z WST 57x-*M	PKG 5Z RKT 57x-*M	PKG 5Z WKT 57x-*M
	Pin (Male)	<b>5</b>  PSG 5	PSG 5 PSG 5 57x-*M	PSG 5 RST 57x-*M	PSG 5 WST 57x-*M	PSG 5 RKT 57x-*M	PSG 5 WKT 57x-*M

See pages H60 - H61 for dimensional drawings.

\* Indicates length in meters.

x Indicates cable type. See page M20 for available cable types.

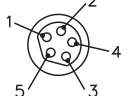
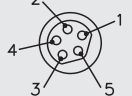
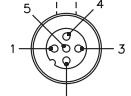
Standard cable lengths are 1, 2, 4, 5, 6, 8, 10, 15, and in +5 meter increments from there. Consult factory for other lengths.

picofast		Pinouts	eurofast	
Male	Female		Male	Female
		1. Bare (Shield Drain Wire) 2. Red (+ Voltage) 3. Black (- Voltage) 4. White (CAN_H) 5. Blue (CAN_L)		

### Specifications

<b>Overmold:</b>	TPU
<b>Coupling Nut:</b>	Nickel Plated CuZn or Stainless Steel (thread), Nylon (snap lock)
<b>Contact Carrier:</b>	TPU or POM (Nylon)
<b>Contacts:</b>	Gold Plated CuZn
<b>Protection:</b>	NEMA 1, 3, 4, 6P and IEC IP 67
<b>Rated Voltage:</b>	30 V
<b>Rated Current:</b>	3 A
<b>Ambient Temperature:</b>	-40° to +75°C (-22° to +167°F)

1

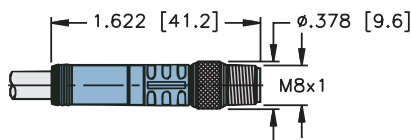

PSG 5M ..

Pages H58 - H59

2

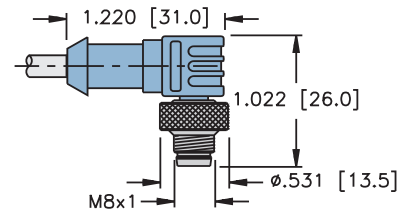

PSW 5M ..

Pages H58 - H59

3

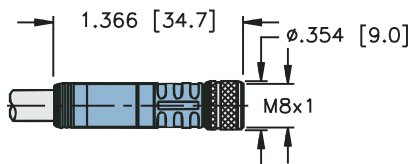

PKG 5M ..

Pages H58 - H59

4

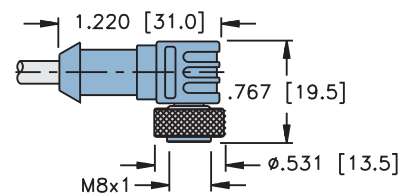

PKW 5M ..

Pages H58 - H59

5

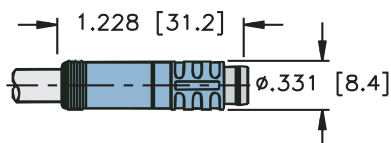

PSG 5 ..

Pages H58 - H59

6

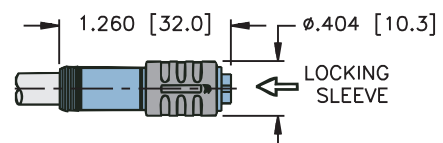

PKG 5Z ..

Pages H58 - H59

# NETWORK WIRING

## DeviceNet™, eurofast® Cable/Cordsets Connector Dimensions

### Specifications

<b>Overmold:</b>	TPU
<b>Coupling Nut:</b>	Nickel Plated CuZn or Stainless Steel
<b>Contact Carrier:</b>	TPU
<b>Contacts:</b>	Gold Plated CuZn
<b>Protection:</b>	NEMA 1, 3, 4, 6P and IEC IP 68
<b>Rated Voltage:</b>	250 V
<b>Rated Current:</b>	4 A
<b>Ambient Temperature:</b>	-40° to +75°C (-22° to +167°F)

7

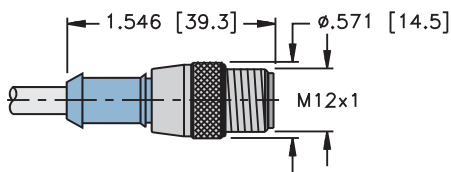

RST ..

Pages H58 - H59

8

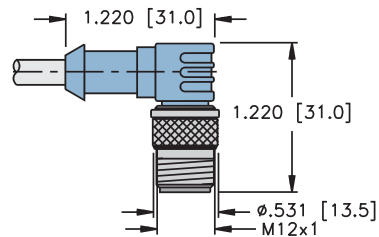

WST ..

Pages H58 - H59

9

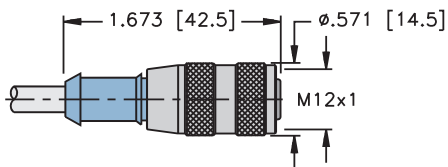

RKT ..

Pages H58 - H59

10

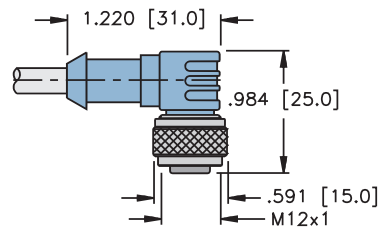

WKT ..

Pages H58 - H59

## DeviceNet™, Terminating Resistors

- Terminating Resistors Stabilize and Minimize Reflections on the Bus Line
- A Terminating Resistor is Required at the Beginning and End of the Main Bus Line



Housing Style	Part Number	Specs	Pinouts
	RSM 57-TR2	Nickel plated brass or stainless steel, 300 V (7.6 V max. on pins with resistor), -40° to +80°C, IP 67, 120 Ohms, 1/2 W internal resistance	<b>Male</b> 
	RKM 57-TR2	Nickel plated brass or stainless steel, 300 V (7.6 V max. on pins with resistor), -40° to +80°C, IP 67, 120 Ohms, 1/2 W internal resistance,	<b>Female</b> 
	RSM 57-TR2/VM	Nickel plated brass or stainless steel, 24 V (7.6 V max. on pins with resistor), -40° to +80°C, IP 67, 120 Ohms, 1/2 W internal resistance, voltage monitoring Led indication: Red - reverse polarity Green-okay	<b>Male</b> 
	RSE 57-TR2	Nickel plated CuZn or stainless steel, 250 V(7.6 V max. on pins with resistor), 4 A, -40° to +80°C, IP 68, 120 Ohms, 1/2 W internal resistance	<b>Male</b> 
	RKE 57-TR2	Nickel plated CuZn or stainless steel, 250 V (7.6 V max. on pins with resistor), 4 A, -40° to +80°C, IP 68, 120 Ohms, 1/2 W internal resistance	<b>Female</b> 
	RSE 57-TR2/VM	Nickel plated CuZn or stainless steel, 10-30 VDC, -40° to +80°C, IP 68, 120 Ohms, 1/2 W internal resistance, voltage monitoring Led indication: Red - reverse polarity Green-okay	<b>Male</b> 

# NETWORK WIRING

## DeviceNet™, Terminating Resistors

- Terminating Resistors Stabilize and Minimize Reflections on the Bus Line
- A Terminating Resistor is Required at the Beginning and End of the Main Bus Line



Housing Style	Part Number	Features	Pinouts
	PSGM 5M 57-TR	Nickel plated brass or stainless steel, 125 V(7.6 V max on resistor), 2 A, -40° to +105°C, IP 67, male <i>picofast</i> connector, 120 Ohms, 1/2 W internal resistance	<b>Male</b> 
	PKGM 5M 57-TR		<b>Female</b> 

## DeviceNet™, Receptacles

- Receptacles Provide Transition from Male to Female Connectors
- Available for Bulkhead and Feed Through Applications



Housing Style	Part Number	Features	Pinouts
	<b>RSF RKF 57/22</b>	Straight male/female feed through, nickel plated CuZn or stainless steel, 300 V, 9 A, -40° to +75°C, IP 67	<div style="display: flex; justify-content: space-around;"> <div style="text-align: center;"> <p><b>Male</b></p> </div> <div style="text-align: center;"> <p><b>Female</b></p> </div> </div>
	<b>FKM FS 57/M12</b>	Straight male/female feed through, nickel plated CuZn or stainless steel, 150 V, 4 A, -40° to +75°C, IP 67	<div style="display: flex; justify-content: space-around;"> <div style="text-align: center;"> <p><b>Male</b></p> </div> <div style="text-align: center;"> <p><b>Female</b></p> </div> </div>

Standard housing material is nickel plated brass. "RSF RKF.."; "RSFV RKFV.." indicates stainless steel housing.

**Panel Cutout  
RSF RKF 57/22**

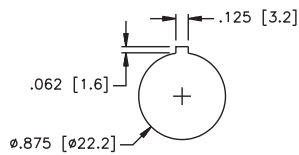

**Panel Cutout  
FKM FS 57/M12**

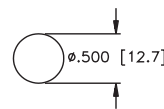

# NETWORK WIRING

## DeviceNet™, eurofast® Drop Junctions

- Creates a Drop or Branch from the Main Bus Line
- Cable Drop Lengths Available Up to a Maximum of 6 Meters



Housing	Part Number	Application	Wiring Diagrams
	VB2-FKM/FKM/FSM 57	Ready for <b>eurofast</b> drop and trunk cordsets Maximum six meter drop	
	VB2-RKC 57x-*M-FKM FSM	Ready for <b>eurofast</b> trunk line, maximum six meter drop	
	VB2-FKM/RKC RSC 57x-*M/*M	Ready for <b>eurofast</b> drop cordsets, maximum six meter branch	

\* Indicates length in meters.

x Indicates cable type.

## Specifications

<b>Overmold:</b>	TPU
<b>Coupling Nut:</b>	Nickel Plated CuZn or Stainless Steel
<b>Contact Carrier:</b>	TPU or POM (Nylon)
<b>Contacts:</b>	Gold Plated CuZn
<b>Protection:</b>	NEMA 1, 3, 4, 6P and IEC IP 68
<b>Rated Voltage:</b>	250 V
<b>Rated Current:</b>	4 A
<b>Ambient Temperature:</b>	-40° to +75°C (-22° to +167°F)

**Mounting:** Mounting hole accepts #8 screw.

**VB2-FKM/FKM/FSM 57**

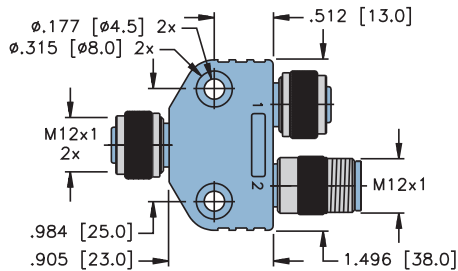

**VB2-RKC 57x-\*M-FKM FSM**

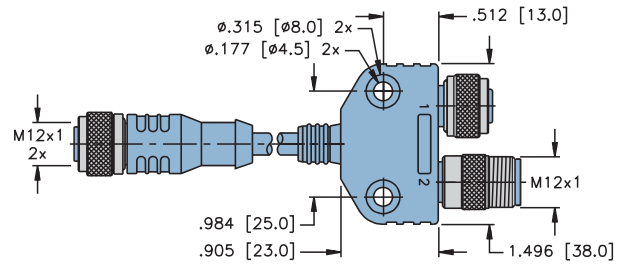

**VB2-FKM/RKC RSC 57x-\*M/\*M**

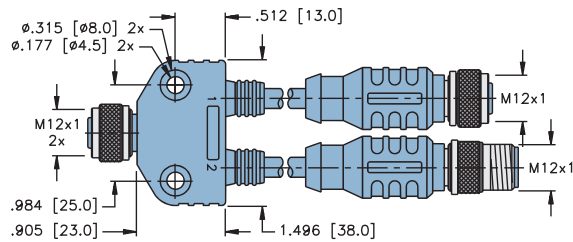

## Pinouts

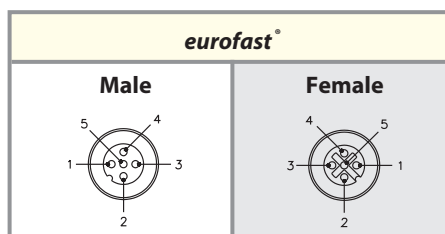

# NETWORK WIRING

## DeviceNet™, Bus Drop and Diagnostic Tees

- Creates a Drop or Branch from the Main Bus Line
- (7/8-16UN) *minifast*® Connectors on Bus and Drop Lines



Housing Style	Part Number	Features	Wiring Diagrams
	RSM-2RKM 57	TPU, 300 V, 9 A, -40° to +75°C, maximum six meter branch, Standard keyway	
	RSM 2RKM 57-KF	TPU, 300 V, 9 A, -40° to +75°C, maximum six meter branch, keyway facing female	
	RSM 2RKM 57-KM	TPU, 300 V, 9 A, -40° to +75°C, maximum six meter branch, keyway facing male	

### Pinouts

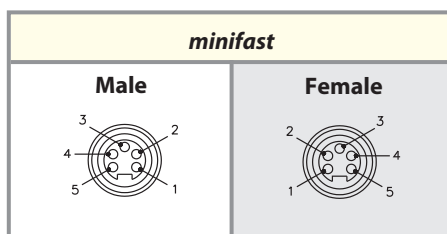

## DeviceNet™, Bus Drop and Diagnostic Tee

- Creates a Drop or Branch from the Main Bus Line
- (7/8-16UN) *minifast*® Connectors on Bus and Drop Lines
- Available in Three Keyway Options
- Different Genders Available
- LED Status Indicator



Housing Style	Part Number	Features	Wiring Diagrams
	SH-RKM/RSM/RKM 57/VM	TPU (Polyurethane), 30 V, 9 A, -40° to +105°C, maximum six meter branch	
	RSM RSM 57-0/VM	TPU (Polyurethane), 30 V, 9 A, -40° to +105°C, maximum six meter branch	
	RSM RKM 57-0/VM	TPU (Polyurethane), 30 V, 9 A, -40° to +105°C, maximum six meter branch	
	RKM RKM 57-0/VM	TPU (Polyurethane), 30 V, 9 A, -40° to +105°C	

### Pinouts

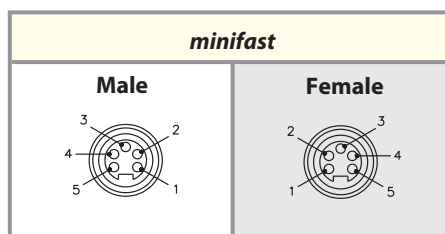

# NETWORK WIRING

## DeviceNet™, Bus Drop and Diagnostic Tee

- Creates a Drop or Branch from the Main Bus Line
- (7/8-16UN) *minifast*® Connectors on Bus and Drop Lines
- Available in Three Keyway Options
- Different Genders Available
- LED Status Indicator



Housing Style	Part Number	Features	Wiring Diagrams
<p>MT-RKM/RSM/RKM 57/DNET/VM</p>	<p>MT-RKM/RSM/RKM 57/DNET/VM</p>	<p>TPU (Polyurethane), 30 V, 9 A, -40° to +105°C</p>	
<p>MT-RSM/2RKM 57/DNET/VM</p>	<p>MT-RSM/2RKM 57/DNET/VM</p>	<p>TPU (Polyurethane), 30 V, 9 A, -40° to +105°C</p>	

## DeviceNet™, Bus Drop and Diagnostic Tee

- Creates a Drop or Branch from the Main Bus Line
- (7/8-16UN) *minifast*® Connectors on Bus and Drop Lines
- Available in Three Keyway Options
- Different Genders Available



Housing Style	Part Number	Features	Wiring Diagrams
	MT-RSM/2RKM 57/DNET		
	SH-RKM/RSM/RKM 57		
	SH-RSM-2RKM 57	TPU (Polyurethane), 30 V, 9 A, -40° to +105°C	
	RSM RSM 57-0		
	RKM RKM 57-0		

DeviceNet™ Media

# NETWORK WIRING

## DeviceNet™, Power and Diagnostic Tees

- Provide a Drop to Insert Power or Diagnostic Equipment
- (7/8-16UN) minifast® Connectors on Bus and Drop Lines
- Reverse Current Protection on Power Tap



Housing Style	Part Number	Features	Wiring Diagrams
	RSM RKM 57 WSM 40 PST	TPU, 300 V, 9 A, -40° to +75°C, bus power tee provides segment power, includes reverse current protection	
	RSM 2RKM 57 DGT	TPU, 300 V, 9 A, -40° to +75°C, bus diagnostic tee provides easy connection for diagnostic tools, tap protected with cover when not in use (not shown)	

### Pinouts

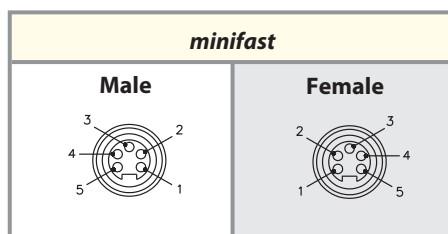

## DeviceNet™, Bus Tees

- Creates a Drop or Branch from the Main Bus Line
- Cable Drop Can Be Up to a Maximum of 6 Meters
- *euromast*® Drop Connector or Extension Cordset



Housing Style	Part Number	Features	Wiring Diagrams
	RSM FKM RKM 57	TPU, 250 V, 4 A, -40° to +75°C, <i>minifast</i> ® to <i>euromast</i> bus power and data drop	
	RSM RKC 57x-M RKM 57	TPU, 250 V, 4 A, -40° to +75°C, <i>minifast</i> to <i>euromast</i> cordset, bus power and data drop	

### Pinouts

<i>minifast</i>		<i>euromast</i>
<b>Male</b> 	<b>Female</b> 	<b>Female</b> 

# NETWORK WIRING

## DeviceNet™, eurofast® Bus Tees

- Creates a Drop or Branch from the Main Bus Line
- Cable Drop Can Be Up to a Maximum of 6 Meters
- eurofast Drop Connector



Housing Style	Part Number	Features	Wiring Diagram
	RSC 2RKC 57	TPU, 250 V, 4 A, -40° to +75°C, <b>eurofast</b> trunk and drop	
	RSC 2RKC 57/KS	TPU, 250 V, 4 A, -40° to +75°C, eurofast trunk and drop, keyway aligns tee in-line on (M8x1) <b>piconet</b> ® boxes	
	RSC RKC 572-*M/RKC 57	TPU, 32 V, 4 A (pins 2,3) 1 A (all others), -40° to +80°C	

### Pinouts

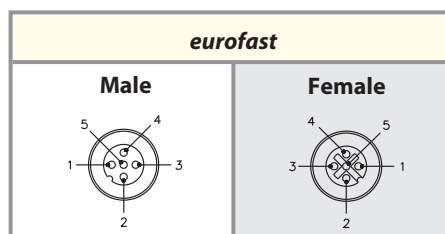

## DeviceNet™, Gender Changers and Elbow Connectors

- Allows Quick and Easy Changes from Male to Female Connectors
- Available in Straight and Right Angle Styles with *minifast*® Connectors



Housing Style	Part Number	Features	
	RSM RKM 57	TPU, 300 V, 9 A, -40° to +80°C, changes female cordset to male cordset	
	RKM RKM 57	TPU, 300 V, 9 A, -40° to +80°C, Changes male cordset to female cordset changes straight male or female cordset to right angle cordset	
	WSM RKM 57	TPU, 300 V, 9 A, -40° to +80°C, right angle male to female connector	

### Pinouts

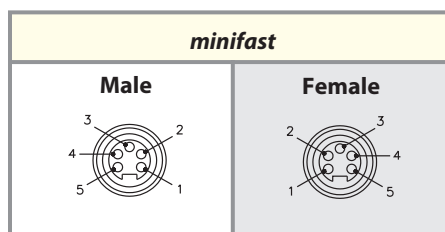

# NETWORK WIRING

## DeviceNet™, Gender Changers and Elbow Connectors

- Allows Quick and Easy Changes from Male to Female and *minifast* to *eurofast* Connectors



Housing Style	Part Number	Features	Wiring Diagrams
	RSM 57-FK 4.5	Nickel plated CuZn or stainless steel, 250 V, 4 A, -40° to +75°C, female eurofast to male minifast adapter	
	RSC RKC 57	Nickel plated CuZn, 250 V, 4 A, -40° to +105°C, male eurofast to female eurofast adapter	
	RSC WKC 57		

### Pinouts

<i>minifast</i>	<i>eurofast</i>	<i>eurofast</i>
Male	Male	Female

## DeviceNet™, (7/8-16UN) minifast® Male Receptacles

- Provides Quick Connection to Field Devices or Enclosures
- Available for 1/2-14NPT, 1/2-14NPSM, 3/4-14NPT and M20 Threads



Housing Style	Female Part Number	Male Part Number	Features	Pinouts
<p><b>RKF 57../14.5</b></p> <p><b>RSF 57../14.5</b></p>	RKF 57-*M/14.5	RSF 57-*M/14.5	Nickel plated CuZn or stainless steel, 300 V, 9 A, -40° to +105°C, 1/2-14NPT full length threads	<p><b>Female</b></p>
<p><b>RKF 57../14.75</b></p> <p><b>RSF 57../14.75</b></p>	RKF 57-*M/14.75	RSF 57-*M/14.75	Nickel plated CuZn or stainless steel, 300 V, 9 A, -40° to +105°C, 3/4-14NPT full length threads	<ol style="list-style-type: none"> <li>GY</li> <li>RD</li> <li>BK</li> <li>WH</li> <li>BU</li> </ol>
<p><b>RKF 57../M20</b></p> <p><b>RSF 57../M20</b></p>	RKF 57-*M/M20	RSF 57-*M/M20	Nickel plated CuZn or stainless steel, 300 V, 9 A, -40° to +105°C, M20x1.5 threads	<p><b>Male</b></p>

\* Length in meters.

Standard cable length is 0.5 meters. Consult factory for other lengths.

Standard housing material is nickel plated brass. "RKF .."; "RKFV .." indicates 316 stainless steel housing.

For locknuts to be included, add "W/LN" to the end of the part number.

# NETWORK WIRING

## DeviceNet™, (7/8-16UN) minifast® Male Receptacles

- Provides Quick Connection to Field Devices or Enclosures
- Available for 1/2-14NPT, 1/2-14NPSM, 3/4-14NPT and M20 Threads



Housing Style	Female Part Number	Male Part Number	Features	Pinouts
<p><b>RKF 57..</b></p> <p><b>RSF 57..</b></p>	RKF 57-*M	RSF 57-*M	Nickel plated CuZn or stainless steel, 300 V, 9 A, -40° to +105°C, 1/2-14NPSM threads	<p><b>Female</b></p> <p><b>Male</b></p>

\* Length in meters.

Standard cable length is 0.5 meters. Consult factory for other lengths.

Standard housing material is nickel plated brass. "RKF .."; "RKFV .." indicates 316 stainless steel housing.

For locknuts to be included, add "W/LN" to the end of the part number.

## DeviceNet™, (M12x1) eurofast® Male Receptacles

- Provides Quick Connection to Field Devices
- Available for 1/2-14NPT, 1/2-14NPSM, 3/4-14NPT and M20 Threads



Housing Style	Female Part Number	Male Part Number	Features	Pinout
<p><b>FK 57../14.5</b></p> <p><b>FS 57../14.5</b></p>	FK 57-*M/14.5	FS 57-*M/14.5	Nickel plated CuZn or stainless steel, 250 V, 4 A, -40° to +105°C, 1/2-14NPT full length threads	<p><b>Female</b></p>
<p><b>FK 57../14.75</b></p> <p><b>FS 57../14.75</b></p>	FK 57-*M/14.75	FS 57-*M/14.75		
<p><b>FK 57.../M20</b></p> <p><b>FS 57.../M20</b></p>	FK 57-*M/M20	FS 57-*M/M20	Nickel plated CuZn or stainless steel, 250 V, 4 A, -40° to +105°C, M20x1.5 threads	<p><b>Male</b></p>

\* Length in meters.  
 Standard cable length is 0.5 meters. Consult factory for other lengths.  
 Standard housing material is nickel plated brass. "RKF .."; "RKfV .." indicates 316 stainless steel housing.

# NETWORK WIRING

## DeviceNet™, (M12x1) eurofast® Male Receptacles

- Provides Quick Connection to Field Devices
- Available for 1/2-14NPT, 1/2-14NPSM, 3/4-14NPT and M20 Threads



Housing Style	Female Part Number	Male Part Number	Features	Pinout
<p><b>FK 57...</b></p> <p><b>FS 57..</b></p>	FK 57-*M	FS 57-*M	Nickel plated CuZn or stainless steel, 250 V, 4 A, -40° to +105°C, PG 9 threads	<p><b>Female</b></p> <p><b>Male</b></p>

\* Length in meters.

Standard cable length is 0.5 meters. Consult factory for other lengths.

Standard housing material is nickel plated brass. "RKF .."; "RKFV .." indicates 316 stainless steel housing.

## DeviceNet™, minifast® PCB and Solder Cup Receptacles

- Provides (7/8-16UN) minifast Connection to Field Devices



Housing Style	Female Part Number	Male Part Number	Features	Pinouts
<p><b>RKF 57 PCB</b></p>	RKF 57-PCB	RSF 57-PCB	Nickel plated CuZn or stainless steel, 300 V, 9 A, -40° to +105°C, <b>minifast</b> PCB pins	<p><b>Female</b></p>
<p><b>RSF 57 PCB</b></p>				
<p><b>RKF 57</b></p>	RKF 57	RSF 57	Nickel plated CuZn or stainless steel, 300 V, 9 A, -40° to +105°C, <b>minifast</b> solder cups	<p><b>Male</b></p>
<p><b>RSF 57</b></p>				

Standard housing material is nickel plated brass "RSFV .."; "RKFV .." indicates 316 stainless steel.

**Panel Cutout**  
FK ... FS

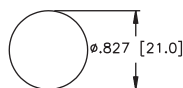

**Board Layout (reference only)**

FK ... FS

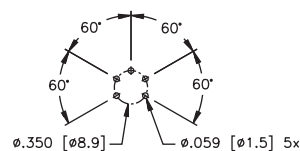

# NETWORK WIRING

## DeviceNet™, eurofast® PCB and Solder Cup Receptacles

- Provides (M12x1) eurofast Connection to Field Devices



Housing Style	Female Part Number	Male Part Number	Features	Pinouts
<p><b>FS 57 PCB KIT</b></p> <p><b>FK 57 PCB KIT</b></p>	FK 57-PCB KIT	FS 57-PCB KIT	Nickel plated CuZn or stainless steel, 250 V, 4 A, -40° to +105°C, male <b>eurofast</b> with mounting kit	<p><b>Male</b></p>
<p><b>FS 57 PCB</b></p> <p><b>FS 57 PCB</b></p>	FK 57-PCB	FS 57-PCB		

Standard housing material is nickel plated brass "FSV ..."; "FKV ..." indicates 316 stainless steel.

### Board Layout (reference only) FK ... FS

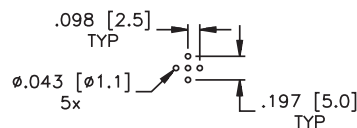

## DeviceNet™, eurofast® PCB Pins and Solder Cup Receptacles

- Provides (M12x1) eurofast Connection to Field Devices



Housing Style	Female Part Number	Male Part Number	Features	Pinouts
<p><b>FKFD 57 PCB</b></p>	FKFD 57-PCB	FSFD 57-PCB	Nickel plated CuZn or stainless steel, 250 V, 4 A, -40° to +105°C, male eurofast PCB pins	<p><b>Female</b></p>
<p><b>FSFD 57 PCB</b></p>				
<p><b>FKFDL 57</b></p>	FKFDL 57	FSFDL 57	Nickel plated CuZn or stainless steel, 250 V, 4 A, -40° to +105°C, male eurofast solder cups	<p>1. BARE 2. RD 3. BK 4. WH 5. BU</p> <p><b>Male</b></p>
<p><b>FSFDL 57</b></p>				
<p><b>WFS 57 PCB</b></p>		WFS 57-PCB	Nickel plated CuZn or stainless steel, 250 V, 4 A, -40° to +105°C, male eurofast right angle PCB pins	

Standard housing material is nickel plated brass "FKFD .."; "FKFDV .." indicates 316 stainless steel.

**Panel Cutout**  
FKFD ... FSFD

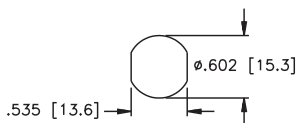

**Board Layout (reference only)**  
FKFD ... FSFD

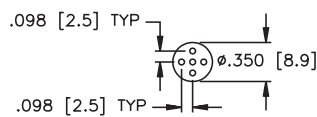

**Panel Cutout**  
WFS

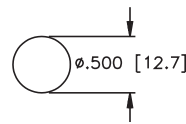

**Board Layout (reference only)**  
WFS

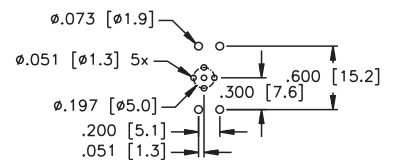

# NETWORK WIRING

## DeviceNet™, minifast® Field Wireable Connectors

- Allows for Quick Connection when Pre-Molded Cables not Available
- Available for Male and Female Connectors
- Color Coded Wire Connections for DeviceNet



Housing Style	Female Part Number	Male Part Number	Features	Pinouts
<p><b>B 4151..</b></p>	<b>B 4151-0/9/DNET</b>	<b>BS 4151-0/9/DNET</b>	Glass filled nylon, PG 9 cable gland, accepts 6-8 mm cable diameter, screw terminals, 85°C, 250 V, 9 A, mates with all 5-pin cordsets and receptacles	<p><b>Female</b></p>
<p><b>BS 4151..</b></p>	<b>B 4251-0/9/DNET</b>	<b>BS 4251-0/9/DNET</b>	Glass filled nylon, PG 9 cable gland, accepts 6-8 mm cable diameter, screw terminals, 85°C, 250 V, 9 A, mates with all 5-pin cordsets and receptacles	
<p><b>B 4251..</b></p>	<b>B 4151-0/13.5/DNET</b>	<b>BS 4151-0/13.5/DNET</b>	Glass filled nylon, PG 13.5 cable gland, accepts 10-12 mm cable diameter, screw terminals 85°C, 250 V, 9 A, mates with all 5-pin cordsets and receptacles	<p><b>Male</b></p>
<p><b>BS 4251..</b></p>	<b>B 4151-0/16/DNET</b>	<b>BS 4151-0/16/DNET</b>	Glass filled nylon, PG 16 cable gland, accepts 12-14 mm cable diameter, screw terminals 85°C, 250 V, 9 A, mates with all 5-pin cordsets and receptacles	

## DeviceNet™, eurofast® Field Wireable Connectors

- Allows for Quick Connection when Pre-Molded Cables not Available
- Available for Male and Female Connectors in Straight or Right-Angle Configurations
- Color Coded Wire Connections for DeviceNet



Housing Style	Female Part Number	Male Part Number	Features	Pinouts
<p><b>B 81...</b></p>	B 8151-0/PG9/DNET	BS 8151-0/PG9/DNET	PBT, Black, PG 9 cable gland, accepts 4-8 mm cable diameter, screw terminals, 85°C, 125 V, 4 A, mates with 5-pin cordsets and receptacles	<p><b>Male</b></p>
<p><b>BS 81...</b></p>				
<p><b>B 82...</b></p>	B 8251-0/PG9/DNET	BS 8251-0/PG9/DNET	PBT, Black, PG 9 cable gland, accepts 4-8 mm cable diameter, screw terminals, 85°C, 125 V, 4 A, mates with 5-pin cordsets and receptacles	<p><b>Female</b></p>
<p><b>BS 82...</b></p>				

# NETWORK WIRING

## DeviceNet™, eurofast® Daisy Chain Configurations

- Multi-drop Harnesses Designed for OEM Applications
- Provides Cost Effective Solution vs. Single Tees and Drops



Part Number	Features
WSC 2VBWK WKC 5724-1.5M-0.2M-0.2M	TPU, 250 V, 4 A, -40° to +75°C, available in custom configurations including length, number of drops and end connector styles

Consult factory for other designs.

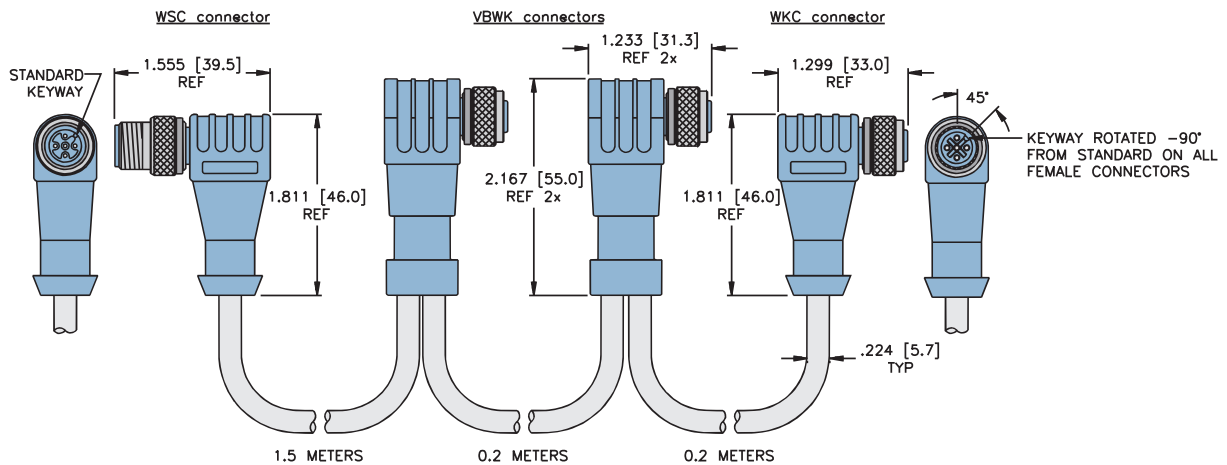

### Pinouts

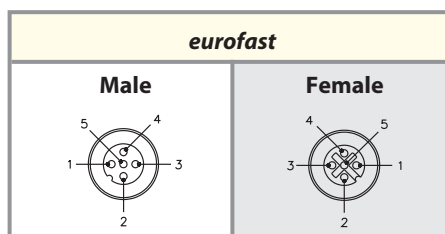

## DeviceNet™, eurofast® Daisy Chain Configurations

- Multi-drop Harnesses Designed for OEM Applications
- Provides Cost Effective Solution vs. Single Tees and Drops



Part Number	Features
RSC 8VBRK RKC 5724-DCL	TPU, 250 V, 4 A, -40° to +75°C, available in custom configurations including length, number of drops and end connector styles

Consult factory for other designs.

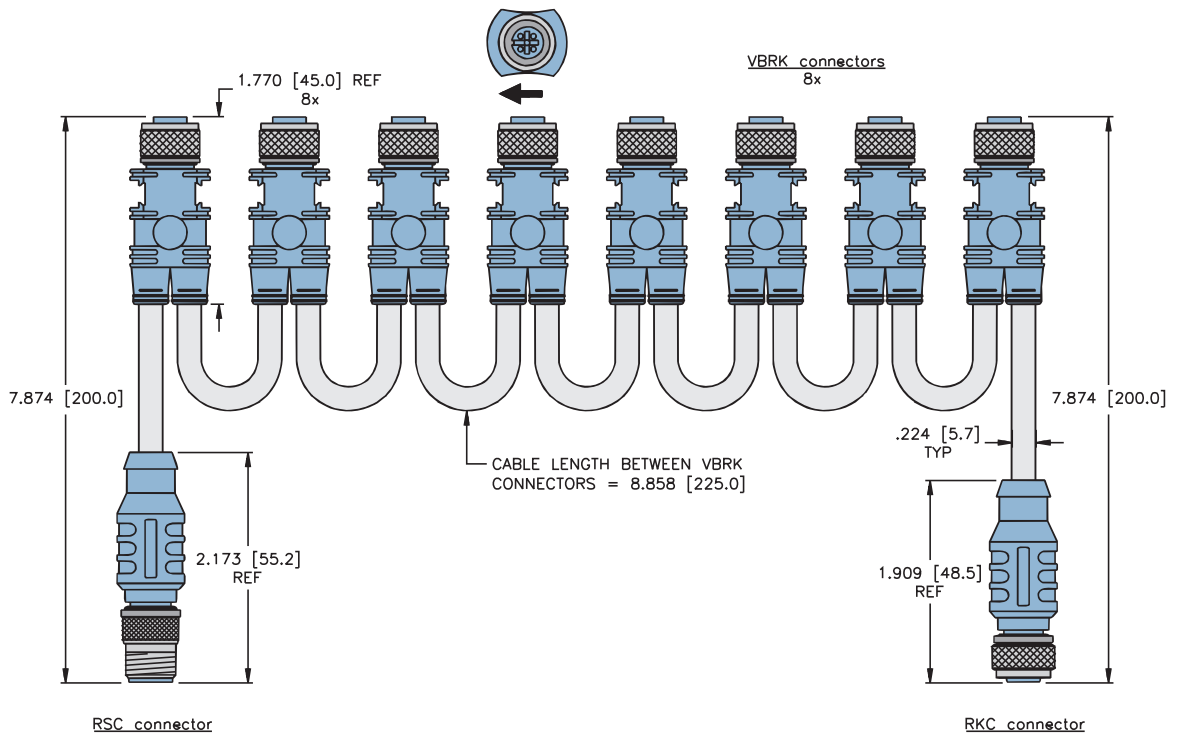

### Pinouts

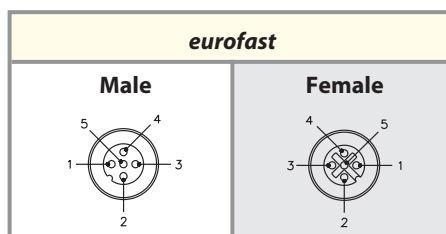

DeviceNet™ Media

# NETWORK WIRING

## DeviceNet™, Conduit Adapters

- Converts Standard Conduits to Quick Disconnect
- Fiberglass Reinforced Nylon Housings
- Nickel Plated Brass Connectors Available
- Gasket and Mounting Screws Provided
- IP67



Housing Style	1-Port Part Number	2-Port Part Number	Specifications	Pinouts
	BCA-57-E123	BCA-57-E223	3/4" Form 8 or Mark 9 conduit to M12x1 adapter, -30°C to +80°C (-22°F to +176°F)	
	BCA-57-M123	BCA-57-M223	3/4" Form 8 or Mark 9 conduit to 7/8"-16UN, -40°C to +75°C (-40°F to +167°F)	
	BCA1-F7-57-M123	BCA1-F7-57-M223	1" Form 7 Conduit Adapter, -40°C to +75°C (-40°F to +167°F)	

## DeviceNet™, Wall Plate Adapters

- Attaches to Standard Single Gang Electrical Box
- Stainless Steel with Stainless Steel Connectors
- Gasket and Mounting Screws Provided
- IP67



Housing Style	M12x1 Part Number	7/8-16UN Part Number	Specifications	Pinouts
	BPA-57-E113	BPA-57-M113	IP67 rated, -40°C to +75°C (-40°F to +167°F)	 

# DISTRIBUTED I/O SALES GUIDE



Industrial Automation

## DeviceNet™, On-Machine Passive Junction Boxes

- Multiple Port Configurations Available
- Cast Aluminum Housing\*
- 7/8" x 1 Bus In/Bus Out Connectors\*
- Stainless Steel Connectors Available
- IP67

\*(Unless otherwise specified)



Housing Style	Part Number	Specifications	Pinouts
	<b>JBBS-57-E1001</b>	10 M12 x 1 Drops, -40°C to +75°C (-40°F to +167°F)	
	<b>JBBS-57-E801</b>	CSA General purpose approval, 8 M12 x 1 Drops, -40°C to +75°C (-40°F to +167°F)	
	<b>JBBS-57-M601</b>	CSA General purpose approval, 6 7/8 x 1 Drops, -40°C to +75°C (-40°F to +167°F)	
	<b>JBBS-57-M801</b>	CSA General purpose approval, 8 7/8 x 1 Drops, -40°C to +75°C (-40°F to +167°F)	
	<b>JBBS-57-T601</b>	Terminal Bus-in/Bus-out with 6 Terminal Drops, -40°C to +75°C (-40°F to +167°F)	
	<b>JBBS-57-E401</b>	CSA General purpose approval, 4 M12 x 1 Drops, -40°C to +75°C (-40°F to +167°F)	
	<b>JBBS-57-E601</b>	CSA General purpose approval, 6 M12 x 1 Drops, -40°C to +75°C (-40°F to +167°F)	
	<b>JBBS-57-M401</b>	CSA General purpose approval, 4 7/8"-16UN drops, -40°C to +75°C (-40°F to +167°F)	

DeviceNet™ Media

# NETWORK WIRING

## DeviceNet™, On-Machine Passive Junction Boxes

- Multiple Port Configurations Available
- Cast aluminum Housing\*
- 7/8" x 1 Bus In/Bus Out Connectors\*
- Stainless Steel Connectors Available
- IP67

\*(Unless otherwise specified)



Housing Style	Part Number	Specifications	Pinouts
	<b>JBBS-57-E811</b>	Fiberglass Housing, 8 M12 x 1 Drops, CSA General purpose approval, -40°C to +75°C (-40°F to +167°F)	
	<b>JBBS-57-E1021</b>	Fiberglass Housing, 10 M12 x 1 Drops, -40°C to +70°C (-40°F to +158°F)	
	<b>JBBS-57-E621</b>	Fiberglass Housing, 6 M12 x 1 Drops, CSA General purpose approval, -40°C to +75°C (-40°F to +167°F)	
	<b>JBBS-57-E821</b>	Fiberglass Housing, 8 M12 x 1 Drops, CSA General purpose approval, -40°C to +75°C (-40°F to +167°F)	

# DISTRIBUTED I/O SALES GUIDE



Industrial Automation

## DeviceNet™, On-Machine Passive Junction Boxes

- Multiple Port Configurations Available
- Cast aluminum Housing\*
- 7/8" x 1 Bus In/Bus Out Connectors\*
- Stainless Steel Connectors Available
- IP67

\*(Unless otherwise specified)



Housing Style	Part Number	Specifications	Pinouts
	JBBS-57-E421	Fiberglass Housing, 4 M12 x 1 Drops, CSA General purpose approval, -40°C to +75°C (-40°F to +167°F)	
	JBBS-57-FS-E424	Fiberglass Reinforced Nylon Housing, M12 x 1 Bus-in with 4 M12 x 1 Drops, -40°C to +70°C (-40°F to +158°F)	

DeviceNet™ Media

# NETWORK WIRING

## DeviceNet™, In-Cabinet Passive Junction Boxes

- Multiple Port Configurations Available
- Extruded Aluminum Housing
- Removable Screw Terminals
- -25°C to +70°C (-13°F to +158°F)
- IP20
- Terminating Resistor Available (P/N: JRBS-57TR)



Housing Style	Part Number w/o Voltage Monitoring	Part Number w/Voltage Monitoring	Specifications	Pinouts
	JRBS-57-8	JRBS-57VM-8	Bus-in/Bus-out plus 8 drops	
	JRBS-57-6	JRBS-57VM-6	Bus-in/Bus-out plus 6 drops	
	JRBS-57-4	JRBS-57VM-4	Bus-in/Bus-out plus 4 drops	

---

<b>Cordsets</b>	<b>H95</b>
<b>Tees</b>	<b>H102</b>
<b>Receptacles</b>	<b>H105</b>
<b>Field Wireables</b>	<b>H109</b>
<b>Adapters/Junctions</b>	<b>H110</b>

---

## Features

- Cables that meet the requirements of Foundation Fieldbus FF-844 Type A Cable
- ITC/PLTC listed cable (CSA FT4)
- Expose Run (ER) and Direct Buried (DB) listed cable
- Oil resistant II and sunlight resistant
- 7/8 and M12 connectors
- Up to 9 Amps and 600 Volt rated
- IP67/IP69K rated

# NETWORK WIRING

## Cable Specifications

- Cables are compliant with FOUNDATION fieldbus FF-844 Cable Specification for Type A cable, IEC 61158-2 and ISA /SP50
- Cables are Available in 3-wire Versions with a Device Ground or 2-wire Versions

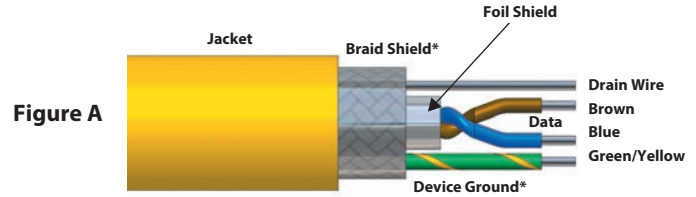

\*Available on some cable types

### Type A Cable Specifications

- Temperature range: -40 to +105°C
- UV Resistant
- PLTC and ITC Listed (CSA FT4)
- Exposed Run (ER) and Direct Buried (DB) Listed
- Maximum Attenuation at 1.25 f<sub>c</sub> (39 kHz) = 3.0 dB/km
- Characteristic Impedance 100 Ω ± 10 Ω @ 31.25 KHz
- Capacitance: 20 pF/Ft nominal
- Inductance: 0.22 μH/Ft. nominal
- Conductor Cross-sectional area (wire size) = nominal 0.75 mm<sup>2</sup> (#18 AWG) or 1.5 mm<sup>2</sup> (#16 AWG)
- Shield Coverage =100 %

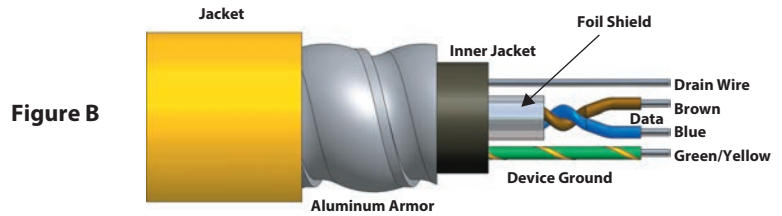

Type	Approvals	Data Pair		Device Ground	Outer Jacket	Shields	Bulk Cable Part Number / Weight/300 M	Figure
		AWG Color Code	DCR (/1000 feet) Insulation	AWG Color Code	Material Color Nominal O.D.	Type Drain Wire		
<b>490</b> AWM 2586 105°C 600 Volts	<b>NEC/UL ITC</b> PLTC Exposed Run, Direct Burial, <b>CEC/CSA</b> [CMG] AWM I/II A/B FT4	2/18 AWG BU/BN	7.06 Ohms XLPE	18 AWG GN/YE	PVC Yellow 8.4 mm (.330 in)	Foil 20 AWG	RB50693-*M 65 lbs.	<b>A</b>
<b>490B</b> AWM 2586 105°C 600 Volts	<b>NEC/UL ITC</b> PLTC Exposed Run, Direct Burial, <b>CEC/CSA</b> [CMG] AWM I/II A/B FT4	2/18 AWG BU/BN	7.06 Ohms XLPE	18 AWG GN/YE	PVC Blue 8.4 mm (.330 in)	Foil 20 AWG	RB50783-*M 65 lbs.	<b>A</b>
<b>492A</b> 105°C 300 Volts	<b>NEC/UL ITC</b> PLTC Exposed Run, Direct Burial, <b>CEC/CSA</b> [CMG] HLABCD, ACIC	2/18 AWG BU/BN	7.06 Ohms XLPE	18 AWG GN/YE	Armor/PVC Yellow 15.6 mm (0.615 in)	Foil 18 AWG	RB50874-*M 108 lbs. <b>armorfast</b> *	<b>B</b>
<b>492BA</b> 105°C 300 Volts	<b>NEC/UL ITC</b> PLTC Exposed Run, Direct Burial, <b>CEC/CSA</b> [CMG] HLABCD, ACIC	2/18 AWG BU/BN	7.06 Ohms XLPE	18 AWG GN/YE	Armor/PVC Blue 15.6 mm (0.615 in)	Foil 18 AWG	RB50803-*M 108 lbs. <b>armorfast</b> *	<b>B</b>

\* Indicates length in meters.  
Standard cable spool lengths are 30, 75, 100, 150, 200, 225 and 300 meters.

## Cable Specifications

- Cable that Meets the Requirements of ISA/SP50 and FOUNDATION™ fieldbus Requirements for Type A Cable
- Cables are Available in 3-wire Versions with a Device Ground or 2-wire Versions

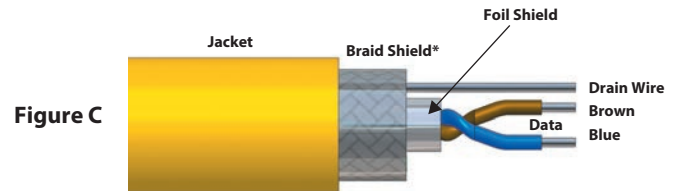

### Type A Cable Specifications

- Temperature range: -40 to +105°C
- UV Resistant
- PLTC and ITC Listed (CSA FT4)
- Exposed Run (ER) and Direct Buried (DB) Listed
- Maximum Attenuation at 1.25 f<sub>c</sub> (39 kHz) = 3.0 dB/km
- Characteristic Impedance 100 Ω ± 10 Ω @ 31.25 KHz
- Capacitance: 20 pF/Ft nominal
- Inductance: 0.22 μH/Ft. nominal
- Conductor Cross-sectional area (wire size) = nominal 0.75 mm<sup>2</sup> (#18 AWG) or 1.5 mm<sup>2</sup> (#16 AWG)
- Shield Coverage = 100 %









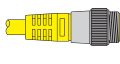

Type	Approvals	Data Pair		Device Ground	Outer Jacket	Shields	Bulk Cable Part Number / Weight/300 M	Figure
		AWG Color Code	DCR (/1000 feet) Insulation					
<b>493</b> AWM 2517 105°C 300 Volts	<b>NEC/UL ITC</b> PLTC Exposed Run, Direct Burial, <b>CEC/CSA</b> [CMG] HLABCD	2/18 AWG BU/BN	7.06 Ohms XLPE	None	PVC Yellow 8.5 mm (.335 in)	Foil/Braid 20 AWG	RB50784-*M 62 lbs.	C
<b>493B</b> AWM 2517 105°C 300 Volts	<b>NEC/UL ITC</b> PLTC Exposed Run, Direct Burial, <b>CEC/CSA</b> [CMG] HLABCD	2/18 AWG BU/BN	7.06 Ohms XLPE	None	PVC Blue 8.5 mm (.335 in)	Foil/Braid 20 AWG	RB50786-*M 62 lbs.	C
<b>4930</b> AWM 2517 105°C 300 Volts	<b>NEC ITC</b> PLTC Exposed Run, Direct Burial <b>CEC</b> [CMG] AWM I/II A/B FT4	2/18 AWG BU/BN	7.06 Ohms XLPE	None	PVC Orange 8.5 mm (.335 in)	Foil/Braid 20 AWG	RB50785-*M 59 lbs.	C
<b>496</b> AWM 2517 105°C 600 Volts	<b>NEC ITC</b> PLTC Exposed Run, Direct Burial <b>CEC</b> [CMG] AWM I/II A/B FT4	2/16 AWG BU/BN	4.5 Ohms XLPE	None	PVC Yellow 9.6 mm (.378 in)	Foil 18 AWG	RB50891-*M 64 lbs.	C
<b>496BK</b> AWM 2517 105°C 300 Volts	<b>NEC ITC</b> PLTC Exposed Run, Direct Burial <b>CEC</b> [CMG] AWM I/II A/B FT4	2/16 AWG BU/BN	4.5 Ohms XLPE	None	PVC Black 9.6 mm (.378 in)	Foil 18 AWG	RB51300-*M 64 lbs.	C

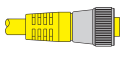
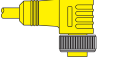
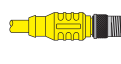
\* Indicates length in meters.  
Standard cable spool lengths are 30, 75, 100, 150, 200, 225 and 300 meters.

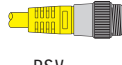
FOUNDATION™ fieldbus

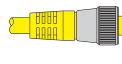
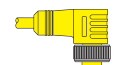
# NETWORK WIRING

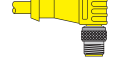
## Cable and Cordset Selection Matrix

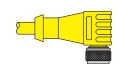
		<i>minifast</i> <sup>®</sup>				<i>eurofast</i> <sup>®</sup>	
		Pin (Male)		Socket (Female)		Pin (Male)	
		 1 RSV	 2 WSV	 3 RKV	 4 WKV	 7 RSCV	
 Bare		RSV 49x-*M	WSV 49x-*M	RKV 49x-*M	WKV 49x-*M	RSCV 49x-*M	
<i>minifast</i>	Pin (Male)	 1 RSV	RSV RSV 49x-*M	RSV WSV 49x-*M	RSV RKV 49x-*M	RSV WKV 49x-*M	RSV RSCV 49x-*M
	Socket (Female)	 2 WSV		WSV WSV 49x-*M	WSV RKV 49x-*M	WSV WKV 49x-*M	WSV RSCV 49x-*M
	Socket (Female)	 3 RKV			RKV RKV 49x-*M	RKV WKV 49x-*M	RKV RSCV 49x-*M
	Socket (Female)	 4 WKV				WKV WKV 49x-*M	WKV RSCV 49x-*M
<i>eurofast</i>	Pin (Male)	 7 RSCV					RSCV RSCV 49x-*M
	Pin (Male)	 8 WSCV					
	Socket (Female)	 9 RKCV					
	Socket (Female)	 10 WKCV					

See pages H97 - H98 for dimensional drawings.

\* Indicates length in meters.

x Indicates cable type.

Standard cable lengths are 1, 2, 4, 6, 8, 10, 15...50 Meters. Consult factory for other lengths.



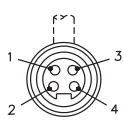
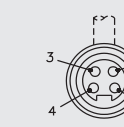
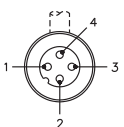
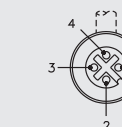



For stainless steel coupling nuts change part number RSM ... to RSV, WSM ... to WSV. For **eurofast armorfast**<sup>®</sup> cable RSC ... to RSA.

<i>minifast</i>		Pinouts	<i>eurofast</i>	
<b>Male</b>	<b>Female</b>	1. Blue (- Voltage) 2. Brown (+ Voltage) 3. Bare (Shield Drain Wire) 4. Green/Yellow (Ground)	<b>Male</b>	<b>Female</b>
				

# DISTRIBUTED I/O SALES GUIDE

## Cable and Cordset Selection Matrix

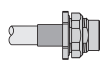

eurofast®			minifast® Bulkhead		eurofast Bulkhead	
Pin (Male)	Socket (Female)		Pin (Male)	Socket (Female)	Pin (Male)	Socket (Female)
 <b>8</b> WSCV	 <b>9</b> RKCV	 <b>10</b> WKCV	 <b>5</b> RSFPV	 <b>6</b> RKFPV	 <b>11</b> FSFDV	 <b>12</b> FKFDV
WSCV 49x-*M	RKCV 49x-*M	WKCV 49x-*M	RSFPV 49x-*M	RKFPV 49x-*M	FSFDV 49x-*M	FKFDV 49x-*M
RSV WSCV 49x-*M	RSV RKCV 49x-*M	RSV WKCV 49x-*M	RSV RSFPV 49x-*M	RSV RKFPV 49x-*M	RSV FSFDV 49x-*M	RSV FKFDV 49x-*M
WSV WSCV 49x-*M	WSV RKCV 49x-*M	WSV WKCV 49x-*M	WSV RSFPV 49x-*M	WSV RKFPV 49x-*M	WSV FSFDV 49x-*M	WSV FKFDV 49x-*M
RKV WSCV 49x-*M	RKV RKCV 49x-*M	RKV WKCV 49x-*M	RKV RSFPV 49x-*M	RKV RKFPV 49x-*M	RKV FSFDV 49x-*M	RKV FKFDV 49x-*M
WKV WSCV 49x-*M	WKV RKCV 49x-*M	WKV WKCV 49x-*M	WKV RSFPV 49x-*M	WKV RKFPV 49x-*M	WKV FSFDV 49x-*M	WKV FKFDV 49x-*M
RSCV WSCV 49x-*M	RSCV RKCV 49x-*M	RSCV WKCV 49x-*M	RSCV RSFPV 49x-*M	RSCV RKFPV 49x-*M	RSCV FSFDV 49x-*M	RSCV FKFDV 49x-*M
WSCV WSCV 49x-*M	WSCV RKCV 49x-*M	WSCV WKCV 49x-*M	WSCV RSFPV 49x-*M	WSCV RKFPV 49x-*M	WSCV FSFDV 49x-*M	WSCV FKFDV 49x-*M
	RKCV RKCV 49x-*M	RKCV WKCV 49x-*M	RKCV RSFPV 49x-*M	RKCV RKFPV 49x-*M	RKCV FSFDV 49x-*M	RKCV FKFDV 49x-*M
		WKCV WKCV 49x-*M	WKCV RSFPV 49x-*M	WKCV RKFPV 49x-*M	WKCV FSFDV 49x-*M	WKCV FKFDV 49x-*M

FOUNDATION™ fieldbus

# NETWORK WIRING

## Cordset and Receptacle Connector Dimensions

### Specifications

<b>Overmold:</b>	TPU
<b>Coupling Nut:</b>	Nickel Plated CuZn or Stainless Steel
<b>Contact Carrier:</b>	TPU
<b>Contacts:</b>	Gold Plated CuZn
<b>Protection:</b>	NEMA 1, 3, 4, 6P and IEC IP 68
<b>Rated Voltage:</b>	300 V
<b>Rated Current:</b>	9 A
<b>Ambient Temperature:</b>	-40° to +105°C (-40° to +221°F)

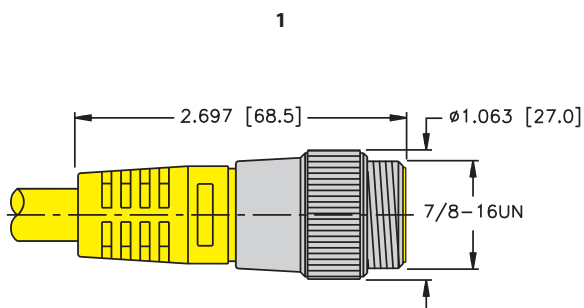

RSV ..

Page H95

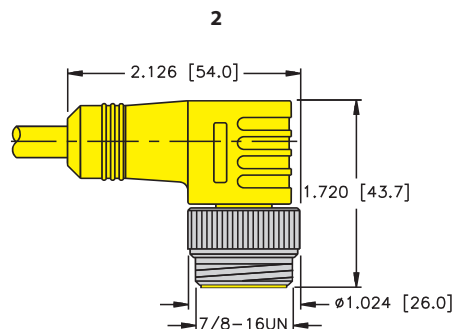

WSV ..

Page H95

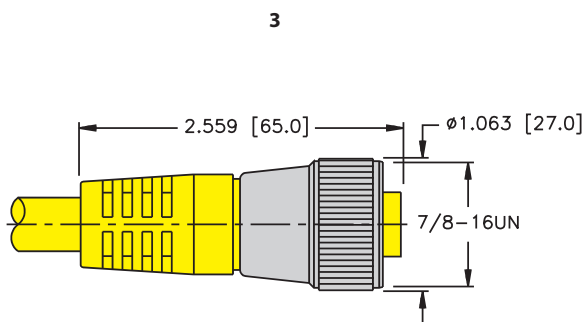

RKV ..

Page H95

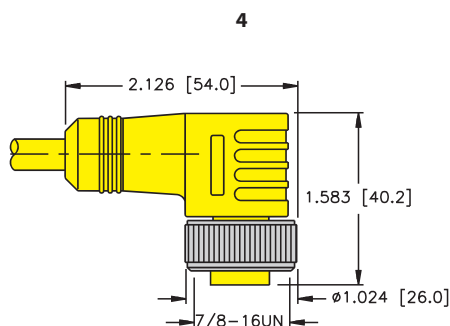

WKV ..

Page H95

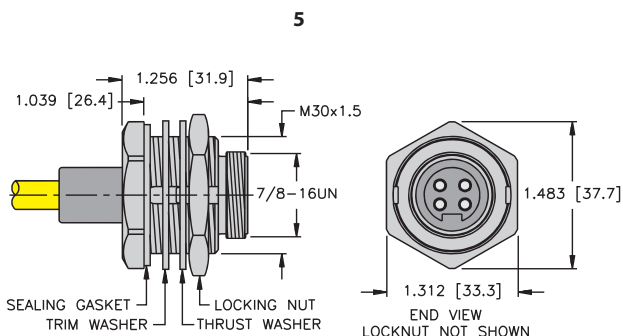

RSFPV ..

Page H95

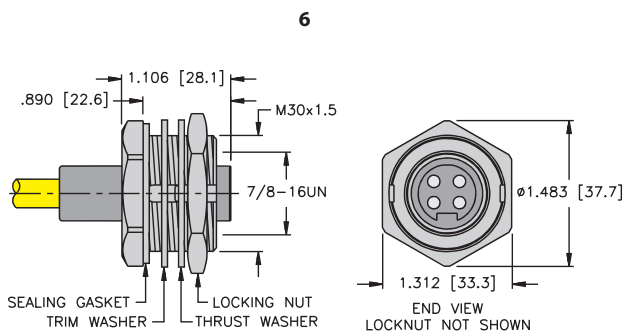

RKFPV ..

Page H95

### Specifications

<b>Overmold:</b>	TPU
<b>Coupling Nut:</b>	Nickel Plated CuZn or Stainless Steel
<b>Contact Carrier:</b>	TPU or POM (Nylon)
<b>Contacts:</b>	Gold Plated CuZn
<b>Protection:</b>	NEMA 1, 3, 4, 6P and IEC IP 68
<b>Rated Voltage:</b>	250 V
<b>Rated Current:</b>	4 A
<b>Ambient Temperature:</b>	-40° to +105°C (-40° to +221°F)

7

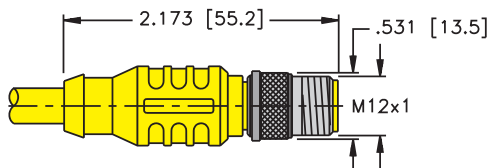

RSCV ..

Page H95

8

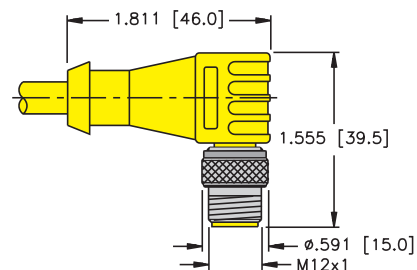

WSCV ..

Page H95

9

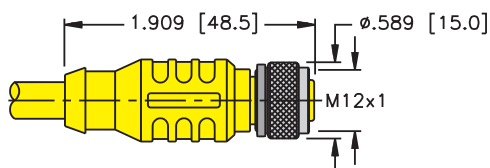

RKCV ..

Page H95

10

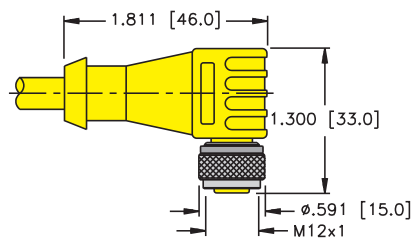

WKCV ..

Page H95

11

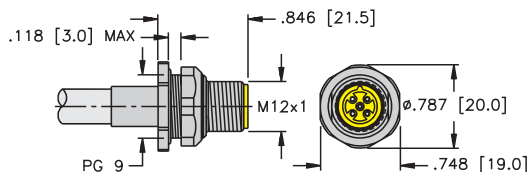

FSFDV ..

Page H95

12

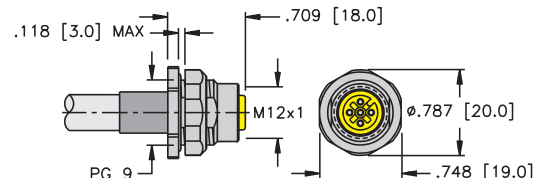

FKFDV ..

Page H95

# NETWORK WIRING

## euromast® Heavy Duty Cordsets

- Heavy Duty Coupling Nut Completely Supports the Molded Plug Body
- Provides Superior Strength



Housing Style	Female Part Number	Male Part Number	Features	Pinouts
<p><b>RKGV..</b></p> <p><b>RSGV..</b></p>	RKGV 49x-*M	RSGV 49x-*M	<p>TPU</p> <p>Nickel plated CuZn or stainless steel, 250 V, 4 A, -40° to +105°C, heavy coupling nut completely supports the molded plug body to provide superior strength</p>	<p><b>Female</b></p> <p><b>Male</b></p>

\* Indicates length in meters.

x Indicates cable type.

For nickel plated brass coupling nut change: RSGV ... to RSG ... or RKGV ... to RKG ...

# DISTRIBUTED I/O SALES GUIDE



## Terminating Resistors

- Terminating Resistors Stabilize and Minimize Reflections on the Bus Line
- A Terminating Resistor is Required at the Beginning and End of the Main Bus Line



Housing Style	Part Number	Features	Pinouts
	RSV 49-TR	Nickel plated brass or stainless steel, 250 V, 4 A, -40° to +75°C, male <i>minifast</i> connector	<p><b>Male</b></p>
	RSEV 49-TR	Nickel plated brass or stainless steel, 250 V, 4 A, -40° to +75°C, male <i>eurofast</i> connector	<p><b>Male</b></p>

# NETWORK WIRING

## Feed Through Connectors

- Receptacles Provide Transition from Male to Female Connectors
- Available for Bulkhead and Feed Through Applications



Housing Style	Part Number	Features	Pinouts
	RSFV RKFV 49/22	Nickel plated CuZn or stainless steel, 300 V, 9 A, -40° to +75°C, straight male/female feed-through, for use with <b>minifast</b> cordsets	<p><b>Male</b></p> <p><b>Female</b></p>
	FKV FSV 49/M12	Nickel plated CuZn or stainless steel, 250 V, 4 A, -40° to +75°C, straight male/female connector, for use with <b>eurofast</b> cordsets	<p><b>Male</b></p> <p><b>Female</b></p>

Standard housing material is nickel plated brass. "RSF RKF .."; "RSFV RKFV .." indicates stainless steel housing.

**Panel Cutout**  
RSF RKF 49/22

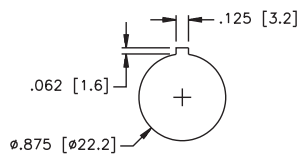

**Panel Cutout**  
FKM FS 49/M12

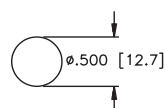

# DISTRIBUTED I/O SALES GUIDE



## Tees

- Creates a Drop or Branch from the Main Bus Line
- *minifast*® Connectors on Bus Line
- *minifast* or *eurofast*® Connectors on Dropline



Housing Style	Part Number	Application	Wiring Diagrams
	<b>RSV-2RKV 49</b>	TPU, 250 V, 4 A, -40° to +75°C, data, ground, shield stainless steel coupling nuts	
	<b>RSV FKV RKV 49</b>	TPU, 250 V, 4 A, -40° to +75°C, data, ground, shield stainless steel coupling nuts	
	<b>RSCV 2RKCV 49</b>	TPU, 250 V, 4 A, -40° to +75°C, stainless steel coupling nuts	
	<b>RSCV WKCV 49</b>	TPU, 250 V, 4 A, -40° to +75°C, stainless steel coupling nuts	
	<b>RSCV RKCV 49</b>	TPU, 250 V, 4 A, -40° to +75°C, stainless steel coupling nuts	

### Pinouts

<i>minifast</i>		<i>eurofast</i>	
<b>Male</b> 	<b>Female</b> 	<b>Male</b> 	<b>Female</b> 

# NETWORK WIRING

## Gender Changers and Elbow Connectors

- Allows Quick and Easy Changes from Male to Female *minifast*® Connectors



Housing	Part Number	Specs	Application	Wiring Diagrams
	RSV RSV 49		<p>Male <i>minifast</i> Gender Changer</p> <ul style="list-style-type: none"> <li>• Changes female cordset to male receptacle</li> </ul>	
	RKV RKV 49	<p>TPU 250 V, 4 A -40° to +75°C</p>	<p>Female <i>minifast</i> Gender Changer</p> <ul style="list-style-type: none"> <li>• Changes female cordset to male receptacle</li> </ul>	
	WSV RKV 49		<p><i>minifast</i> Elbow</p> <ul style="list-style-type: none"> <li>• Right angle male to female connector</li> </ul>	

### Pinouts

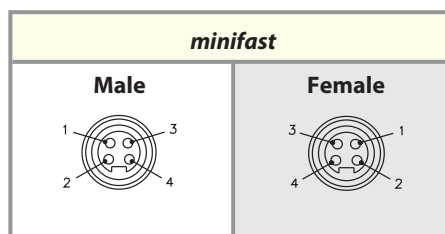

# DISTRIBUTED I/O SALES GUIDE



## Surge Suppressor

- Protects Data Communication Lines (V+ and V-)
- Absorbs the Front End of the Transient, Responding in Less Than a Nanosecond
- Diverts the Surge Energy to Ground
- Automatically Resets and waits for Next Surge



Housing	Part Number	Specs	Application	Pinouts
See Drawing 1	RSV RKV 49 SS	<p><b>Electrical</b></p> <p>Contact Carrier Material . . . . . Thermoplastic Polyurethane</p> <p>Mold Material/Color . . . . . Thermoplastic Polyurethane/Yellow</p> <p>Contact Material/Plating . . . . . Gold-Plated Brass</p> <p>Coupling Nut Material . . . . . Stainless Steel</p> <p>Max. Operating Voltage . . . . . 36 VDC</p> <p>Max. Operating Current . . . . . 600 mA</p> <p>Max. Clamping Voltage . . . . . 58 V</p> <p>Surge Current (8/20µs ≤5 shots). . . . . 20kA</p> <p>Temperature Rating . . . . . -40° to +85°C</p> <p>Protection Class (VDE 0110 b) . . . . . Meets NEMA 1,3,4,6,13</p> <p>Insulation Resistance . . . . . ≥40 MΩ</p> <p>Capacitance Between V+, V- at 24 V . . . . 0.4nF</p> <p><b>Mechanical</b></p> <p>Ground stud . . . . . 10-32 stainless steel</p> <p>Operating temperature . . . . . -40° to +85°C</p>	Male and Female <i>minifast</i> ®, 4-pin	<p><b>Male</b></p> <p><b>Female</b></p>

1

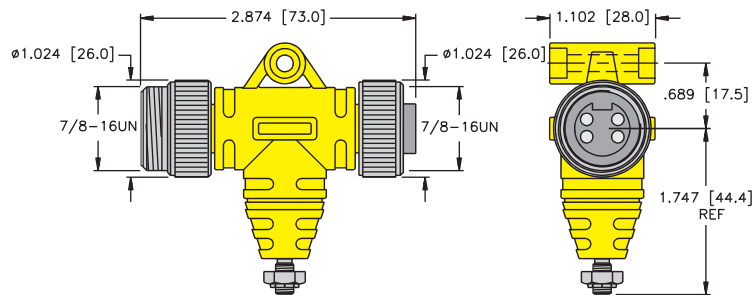

FOUNDATION™ fieldbus

# NETWORK WIRING

## (7/8-16UN) minifast® Receptacles

- Provides Quick Connection to Field Devices
- Available for 1/2-14NPT, 1/2-14NPSM, 3/4-14NPT and M20 Threads



Housing Style	Female Part Number	Male Part Number	Features	Pinout
<p><b>RKFV../14.5</b></p>	RKFV 49-*M/14.5	RSFV 49-*M/14.5	Nickel plated CuZn or stainless steel, 300 V, 9 A, -40° to +105°C, 1/2-14NPT full length threads	<p><b>Female</b></p>
<p><b>RSFV../14.5</b></p>				
<p><b>RKFV../14.75</b></p>	RKFV 49-*M/14.75	RSFV 49-*M/14.75	Nickel plated CuZn or stainless steel, 300 V, 9 A, -40° to +105°C, 3/4-14NPT full length threads	<p><b>Male</b></p>
<p><b>RSFV../14.75</b></p>				
<p><b>RKFV..*M20</b></p>	RKFV 49-*M/M20	RSFV 49-*M/M20	Nickel plated CuZn or stainless steel, 300 V, 9 A, -40° to +105°C, M20x1.5 threads	<p><b>Male</b></p>
<p><b>RSFV..*M20</b></p>				

Standard cable length is 0.5 meters. Consult factory for other lengths.  
 Standard housing material is nickel plated brass housing. "RKF .."; "RKFV .." indicates 316 stainless steel.  
 For locknuts to be included, add "W/LN" to the end of the part number.

# DISTRIBUTED I/O SALES GUIDE



## (7/8-16UN) minifast® Receptacles

- Provides Quick Connection to Field Devices
- Available for 1/2-14NPT, 1/2-14NPSM, 3/4-14NPT and M20 Threads



Housing Style	Female Part Number	Male Part Number	Features	Pinout
<p><b>RKFV..*M</b></p>	RKFV 49-*M	RSFV 49-*M	Nickel plated CuZn or stainless steel, 300 V, 9 A, -40° to +105°C, 1/2-14NPSM threads	<p><b>Female</b></p>
<p><b>RSFV..*M</b></p>				<p><b>Male</b></p>

Standard cable length is 0.5 meters. Consult factory for other lengths.  
 Standard housing material is nickel plated brass housing. "RKF ..", "RKFV .." indicates 316 stainless steel.  
 For locknuts to be included, add "W/LN" to the end of the part number.

### Male End View

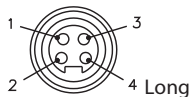

- 1 = BU (-voltage)
- 2 = BN (+ voltage)
- 3 = N/C
- 4 = GN/YE (ground)

### 49 Series

### Male End View



- 1 = BU
- 2 = BN
- 3 = N/C
- 4 = N/C

### 49T Series

### Male End View



- 1 = BU (-voltage)
- 2 = BN (+ voltage)
- 3 = GY
- 4 = N/C

### 49D Series

### Male End View



- 1 = BU (-voltage)
- 2 = BN (+ voltage)
- 3 = GY
- 4 = GN/YE (ground)

### 49E Series

FOUNDATION™ fieldbus

# NETWORK WIRING

## (M12x1) eurofast® Female Receptacles

- Mounted for Quick Connection to Enclosures
- Available for 1/2-14NPT, 1/2-14NPSM, 3/4-14NPT and M20 Threads



Housing	Female Part Number	Male Part Number	Application	Pinout
<p><b>FKV../14.5</b></p> <p><b>FSV../14.5</b></p>	<b>FKV 49-*M/14.5</b>	<b>FSV 49-*M/14.5</b>	Nickel plated CuZn or stainless steel, 250 V, 4 A, -40° to +105°C, 1/2-14NPT full length threads	<p><b>Female</b></p>
<p><b>FKV../14.75</b></p> <p><b>FSV../14.75</b></p>	<b>FKV 49-*M/14.75</b>	<b>FSV 49-*M/14.75</b>	Nickel plated CuZn or stainless steel, 250 V, 4 A, -40° to +105°C, 3/4-14NPT full length threads	
<p><b>FKV 49-*M/M20</b></p> <p><b>FSV 49-*M/M20</b></p>	<b>FKV 49-*M/M20</b>	<b>FSV 49-*M/M20</b>	Nickel plated CuZn or stainless steel, 250 V, 4 A, -40° to +105°C, M20x1.5 Threads	<p><b>Male</b></p>

Standard cable length is 0.5 meters. Consult factory for other lengths.  
 Standard housing material is stainless steel. "RKF .."; "RKFV .." indicates 316 nickel plated brass housing.

# DISTRIBUTED I/O SALES GUIDE



## (M12x1) eurofast® Female Receptacles

- Mounted for Quick Connection to Enclosures
- Available for 1/2-14NPT, 1/2-14NPSM, 3/4-14NPT and M20 Threads



Housing	Female Part Number	Male Part Number	Features	Pinout
<p><b>FKV..*M</b></p>	FKV 49-*M	FSV 49-*M	Nickel plated CuZn or stainless steel, 250 V, 4 A, -40° to +105°C, 1/2-14NPSM threads	<p><b>Female</b></p>
<p><b>FSV..*M</b></p>				<p><b>Male</b></p>

Standard cable length is 0.5 meters. Consult factory for other lengths.  
 Receptacles require a 13/16" (21.0 mm) clearance hole for panel mounting.  
 Standard housing material is stainless steel. "RKF .."; "RKFV .." indicates 316 nickel plated brass housing.

### Male End View

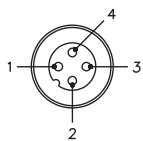

- 1 = BU (-voltage)
- 2 = BN (+ voltage)
- 3 = N/C
- 4 = GN/YE (ground)

### 49 Series

### Male End View

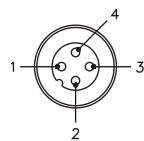

- 1 = BU (-voltage)
- 2 = BN (+ voltage)
- 3 = N/C
- 4 = N/C

### 49T Series

### Male End View

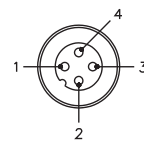

- 1 = BU (-voltage)
- 2 = BN (+ voltage)
- 3 = GY
- 4 = N/C

### 49D Series

### Male End View

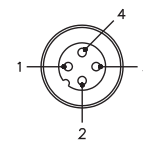

- 1 = BU (-voltage)
- 2 = BN (+ voltage)
- 3 = GY
- 4 = GN/YE (ground)

### 49E Series

FOUNDATION™ fieldbus

# NETWORK WIRING

## minifast® Field Wireable Connectors with Labels

- Allows for Quick Connection when Pre-Molded Cables are not Available
- Available for Male and Female Connectors
- Color Coded Wire Connection for FOUNDATION fieldbus



Housing Style	Female Part Number	Male Part Number	Features	Pinouts
	BKV 4140-0/11/FF	BSV 4140-0/11/FF	Glass filled nylon, stainless steel coupling nut, PG 9 cable gland, accepts 8-10 mm cable diameter, screw terminals, 90°C, 300 V, 9 A, mates with standard, 4-pin cordsets and receptacles	<p><b>Female</b></p>
	BKV 4140-0/16/FF	BSV 4140-0/16/FF	Glass filled nylon, stainless steel coupling nut, PG 16 cable gland, accepts 12-14 mm cable diameter, screw terminals, 90°C, 600 V, 9 A, mates with standard, 4-pin cordsets and receptacles	<p><b>Male</b></p>

## Gender Changer

- Allows Quick and Easy Changes from Male to Female and *minifast*® to *eurofast*® Connectors



Housing Style	Part Number	Features	Wiring Diagram
	RSM 49-FK 4.4	Nickel plated CuZn or stainless steel, 250 V, 4 A, -40° to +75°C, female <i>eurofast</i> , male <i>minifast</i> , 4-pin	

### Pinouts

<i>minifast</i>	<i>eurofast</i>
<p><b>Male</b></p>	<p><b>Female</b></p>

# DISTRIBUTED I/O SALES GUIDE



## FOUNDATION™ fieldbu , Conduit Adapters

- Converts Standard Conduits to Quick Disconnect
- Fiberglass Reinforced Nylon Housings
- Nickel Plated Brass Connectors Available
- 3/4" Form 8 or Mark 9
- 1" Form 7 Available Upon Request
- Gasket and Mounting Screws Provided
- IP67



Housing Style	1 Port Part Number	2 Port Part Number	Specifications	Pinout
	BCA-49-E123	BCA-49-E223	3/4" Form 8 or Mark 9, M12 x 1 stainless steel connectors	
	BCA-49-M123	BCA-49-M223	3/4" Form 8 or Mark 9, 7/8"-16UN stainless steel connectors	
	BCA-49SC-M123	BCA-49SC-M223	Short circuit protection, 3/4" Form 8 or Mark 9, 7/8"-16UN stainless steel connectors	

FOUNDATION fieldbus™ Media

# NETWORK WIRING

## FOUNDATION™ fieldbu , Wall Plate Adapters

- Attaches to Standard Single Gang Electrical Box
- Stainless Steel with Stainless Steel Connectors
- Gasket and Mounting Screws Provided
- IP67



Housing Style	Part Number	Specifications	Pinout
	<p><b>BPA-49-M113</b></p>	<p>7/8"-16UN, -40°C to +75°C (-40°F to +167°F)</p>	

# DISTRIBUTED I/O SALES GUIDE



Industrial Automation

## FOUNDATION™ fieldbu , On-Machine Passive Junction Box

- Multiple Port Configurations Available
- Cast aluminum Housing\*
- 7/8" x 1 Bus in/Bus out Connectors\*
- Nickel Plated Brass Connectors Available
- CSA General Purpose
- -40°C to +75°C (-40°F to +167°F)
- IP67

\*(Unless otherwise specified)



Housing Style	Part Number	Specifications	Pinouts
	JBBS-49-E813	M12x1 Bus-in/Bus-out plus 8 drops	
	JBBS-49-M613	7/8"-16UN Bus-in/Bus-out plus 6 drops	
	JBBS-49-M813	7/8"-16UN Bus-in/Bus-out plus 8 drops	
	JBBS-49SC-E413	M12x1 Bus-in/Bus-out plus 4 drops, short circuit protection	
	JBBS-49SC-E613	M12x1 Bus-in/Bus-out plus 6 drops, short circuit protection	
	JBBS-49SC-E813	M12x1 Bus-in/Bus-out plus 8 drops, short circuit protection	
	JBBS-49SC-M413	7/8"-16UN Bus-in/Bus-out plus 4 drops, short circuit protection	
	JBBS-49SC-M613	7/8"-16UN Bus-in/Bus-out plus 6 drops, short circuit protection	
	JBBS-49SC-M813	7/8"-16UN Bus-in/Bus-out plus 8 drops, short circuit protection	
	JBBS-49-E413	M12x1 Bus-in/Bus-out plus 4 drops	
	JBBS-49-M413	7/8"-16UN Bus-in/Bus-out plus 4 drops	

FOUNDATION fieldbus™ Media

# NETWORK WIRING

## FOUNDATION™ fieldbu , On-Machine Passive Junction Boxes

- Multiple Port Configurations Available
- Aluminum , Fiberglass or Stainless Steel Housings Available
- Short-Circuit Protection or Standard Wired
- -40°C to +75°C (-40°F to +167°F)
- IP67, IP68 and IP69k
- Terminating Resistors Available (P/N: RSV 49 TR)



Housing Style	Part Number	Specifications	Pinouts
	<b>JBBS-49-E623</b>	M12x1 Bus-in/Bus-out plus 6 drops, fiberglass housing	
	<b>JBBS-49-E823</b>	M12x1 Bus-in/Bus-out plus 8 drops, fiberglass housing	
	<b>JBBS-49-M623</b>	7/8"-16UN Bus-in/Bus-out plus 6 drops, fiberglass housing	
	<b>JBBS-49-M823</b>	7/8"-16UN Bus-in/Bus-out plus 8 drops, fiberglass housing	

# DISTRIBUTED I/O SALES GUIDE

## FOUNDATION™ fieldbu , On-Machine Passive Junction Boxes

- Multiple Port Configurations Available
- Cast Aluminum Housing\*
- 7/8" x 1 Bus In/Bus Out Connectors\*
- Nickel Plated Brass Connectors Available
- CSA General Purpose
- -40°C to +75°C (-40°F to +167°F)
- IP67

\*(Unless otherwise specified)



Housing Style	Part Number	Specifications	Pinouts
	<b>JBBS-49SC-M653</b>	7/8"-16UN Bus-in/Bus-out plus 6 drops, cast stainless steel housing, short circuit protection	
	<b>JBBS-49SC-M853</b>	7/8"-16UN Bus-in/Bus-out plus 8 drops, cast stainless steel housing, short circuit protection	
	<b>JBBS-49-E423</b>	M12x1 Bus-in/Bus-out plus 4 drops, fiberglass housing	
	<b>JBBS-49-M423</b>	7/8"-16UN Bus-in/Bus-out plus 4 drops, fiberglass housing	

FOUNDATION fieldbus™ Media

# NETWORK WIRING

## FOUNDATION™ fieldbu , In-Cabinet Passive Junction Boxes

- Multiple Port Configurations Available
- Extruded Aluminum Housing
- Removable Screw Terminals
- Short-circuit Protection
- -30°C to +70°C (-22°F to +158°F)
- IP20
- Terminating Resistors Available (P/N: JRBS-49TR)



Housing Style	Part Number	Specifications	Pinouts
	JRBS-49SC-12R	Bus-in/Bus-out plus 12 drops	No Image Supplied
	JRBS-49SC-10R	Bus-in/Bus-out plus 10 drops	No Image Supplied
	JRBS-49SC-8R	Bus-in/Bus-out plus 8 drops	No Image Supplied

# DISTRIBUTED I/O SALES GUIDE



## FOUNDATION™ fieldbu , In-Cabinet Passive Junction Boxes

- Multiple Port Configurations Available
- Extruded Aluminum Housing
- Removable Screw Terminals
- Short-circuit Protection
- -30°C to +70°C (-22°F to +158°F)
- IP20
- Terminating Resistors Available (P/N: JRBS-49TR)



Housing Style	Part Number	Specifications	Pinouts
	JRBS-49SC-6R	Bus-in/Bus-out plus 6 drops	No Image Supplied
	JRBS-49SC-4R	Bus-in/Bus-out plus 4 drops	No Image Supplied

FOUNDATION fieldbus™ Media

# DPC-System (Diagnostic Power Conditioner)

The DPC-System (Diagnostic Power Conditioner) is a power supply system for the installation of FOUNDATION™ fieldbus H1 segments. It provides comprehensive diagnostic functions for monitoring FOUNDATION fieldbus segments, and supports asset management for the entire system. This includes asset management of the physical layer which is extremely valuable.

**A** - DPC-49-IPS1 - galvanically isolated voltage supply (isolated power supply).

**B** - Diagnostic module "DPC-49-ADU" OR "DPC-49-DU"

**C** - Connection for the diagnostic bus

**D** - Address switch "Addr." for diagnostic bus multiplexing

**E** - H1 connections to the host

**F** - H1 connections into the field

**G** - Connection for the "alarm relay"

**H** - Power supply - Pwr A/Pwr B

**I** - Shield connection

**J** - Connection of the housing - potential equalization

**K** - Overvoltage protection and EMC filter

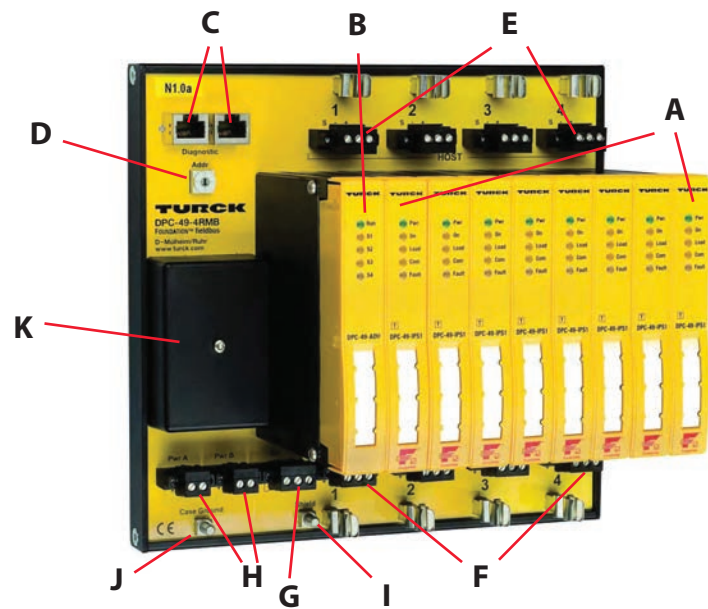

DPC system consists of one or more module racks (DPC-49-4RMB) each with up to eight power supply modules (DPC-49-IPS1) and one diagnostic module (DPC-49-ADU). Up to four H1 segments for each module rack can be operated and monitored redundantly. The diagnostic data from the H1 segments is transmitted via the HSE interface module (DPC-49-HSEFD/24VDC) to the higher level asset management system.

The diagnostic module (DPC-49-ADU) is used as a communication and diagnostic interface between the H1 segments and the power supply module. The diagnostics module monitors the electrical parameters and the communication parameters of the H1 segments. Operation without diagnostic module is possible. In this configuration, simple diagnostics are provided locally.

The diagnostic information is collected in the device and transmitted via the HSE interface module to the higher fieldbus level (e.g. to the host) as diagnostic and alarm data. The diagnostic module can be plugged and unplugged during operation (hot swappable).

The DPC system provides complete galvanic isolation; H1 to H1, H1 to 24 VDC power ADU/DU to H1, and HSE to H1. The DPC system can also be used to supply devices in hazardous classified areas when FISCO power supplies/repeaters or multibarriers from TURCK are used.

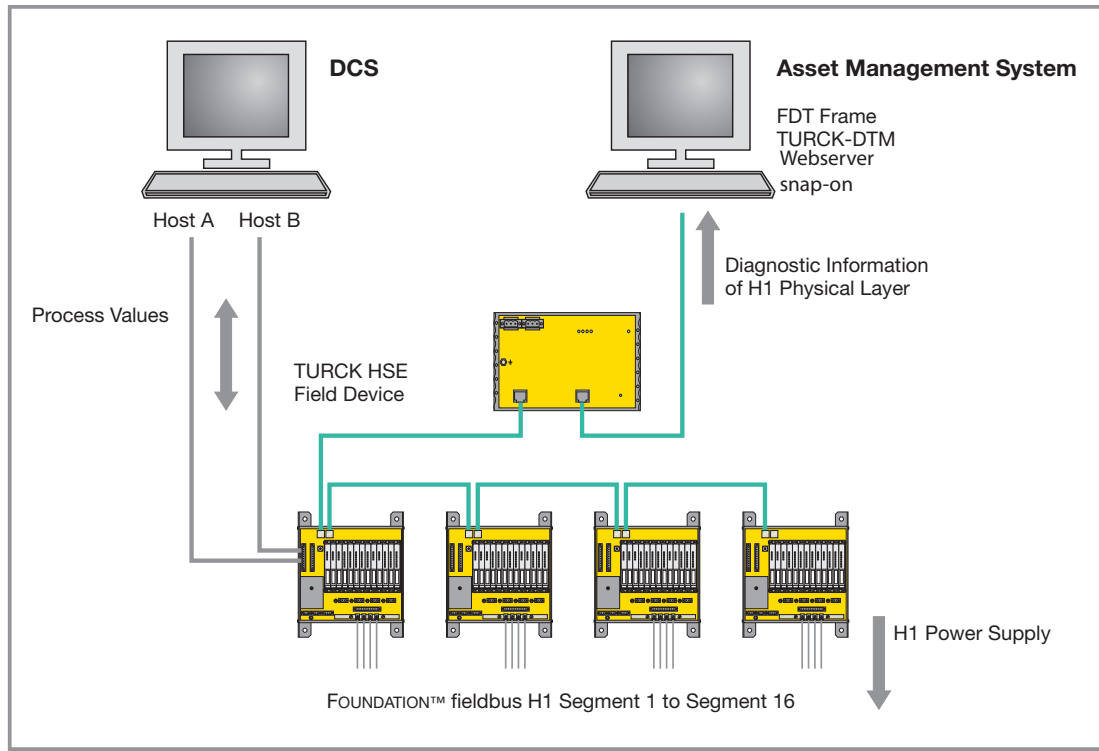

With the DPC system, the physical layer components are continuously monitored providing information regarding the quality and the status of the communication link. This aspect of the system is the key to achieving the main objective of asset management: to minimize maintenance and lower system operating costs. TURCK has made drastic improvements to existing physical layer components for use in FOUNDATION™ fieldbus applications. By continuously monitoring every physical layer component, the DPC treats the entire physical as an asset and manages it accordingly. The DPC system also supports the set-up of fieldbus assets by using localization of error sources, as well as documentation indicating a “good condition” of the segment structure. The DPC system provides an option for redundant segment supplies. The system provides an option for redundant segment supplies. The system, fully loaded, can accommodate up to 16 fully redundant FOUNDATION fieldbus segments, each with an output of 800 mA and 30 VDC.

### Extending H1 Fieldbus Diagnostics via HSE

TURCK’s FF Power Alert SNAP-ON provides H1 physical layer diagnostics from multiple segments and sends them directly into AMS Device Manager.

Additionally, with the DPC-49-HSEFD/24VDC embedded webserver, you have the ability to view, record, and parameterize alarms (a maximum of 192 field devices or 12 devices per segment) from any computer on the network.

# NETWORK WIRING

## FOUNDATION™ Fieldbus Power Supply or FF Diagnostic Power Conditioner

- Provides 800 mA per Segment
- Provides Single or Redundant Segment Power
- Up to 4 Redundant Segments per Backplane
- Monitors Electrical Alarms such as Supply Voltage and Segment Current.
- Monitors Physical Layer Communication Alarms such as LAS Level, Noise, Jitter, Ripple, Field Device Signal, Idle Time, and Frame Errors.

Housing Style	Part Number
<p>Technical drawing of a power supply housing. The front view shows a vertical rectangular housing with a central slot. Dimensions include a height of 4.646 [118.0] REF and a width of .709 [18.0] REF. The side view shows a depth of 4.173 [106.0] REF.</p>	<p>DPC-49-ADU</p> <p>DPC-49-DU</p> <p>DPC-49-IPS1</p> <p>DPC-49-BM-DPC</p>
<p>Technical drawing of a power supply housing. The front view shows a vertical rectangular housing with a central slot and internal components visible. Dimensions include a height of 8.268 [210.0] REF and a width of 1.654 [42.0] REF. The side view shows a depth of 4.299 [109.2] REF.</p>	<p>DPC-49-1RMB</p>

# DISTRIBUTED I/O SALES GUIDE



Protocol	Description	Segments	Connectors	Relay Output	Temperature
Foundation Fieldbus	Advanced Diagnostic Card	up to 16	NA	NA	-20...+60°C
Foundation Fieldbus	Basic Diagnostic Card	up to 16	NA	NA	-20...+60°C
Foundation Fieldbus	Power Supply Card	1	NA	NA	-20...+60°C
Foundation Fieldbus	Dummy Module Card	NA	NA	NA	-20...+60°C
Foundation Fieldbus	DPC Backplane	1	Removable Terminal Blocks	Yes	-20...+60°C



FOUNDATION fieldbus™ Media

# NETWORK WIRING

## FOUNDATION™ Fieldbus Power Supply Accessories

- Up to 16 Redundant Segments per HSE Field Device
- HSE Webserver for Electrical and Physical Layer Communication Alarms

Housing Style		Part Number
		DPC-49-4RMB
		DPC-49-4RMB/Y0
		DPC-49-HSEFD/24VDC

# DISTRIBUTED I/O SALES GUIDE



Protocol	Description	Segments	Connectors	Relay Output	Temperature
FOUNDATION Fieldbus-H1	DPC Backplane	4	Removable Terminal Blocks, RJ45 Connectors	Yes	-20...+60°C
FOUNDATION Fieldbus-H1	DPC Backplane with Host connection for AKB336 Yokogawa system connector	4	Removable Terminal Blocks, RJ45 Connectors	Yes	-20...+60°C
FOUNDATION Fieldbus-HSE	High Speed Ether- net Device	16	Removable Terminal Blocks, RJ45 Connectors	NA	-20...+60°C

FOUNDATION fieldbus™ Media

# NETWORK WIRING

## FOUNDATION™ Fieldbus FISCO Power Supply and Multi-barrier

- FISCO Compliant Power Supplies
- PROFIBUS PA or Foundation Fieldbus Multibarrier
- Powder-coated Die Cast Aluminum Housing

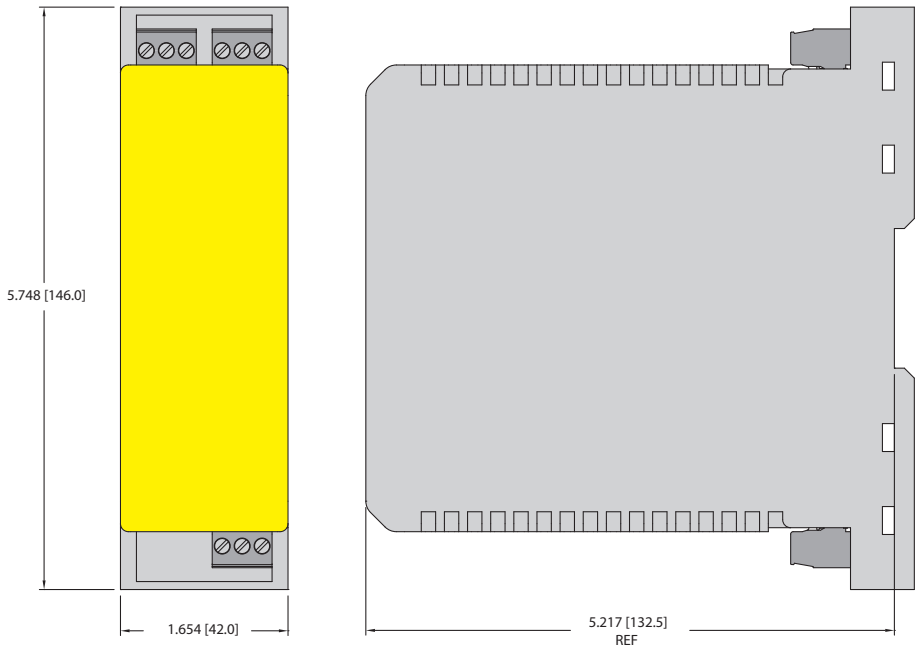
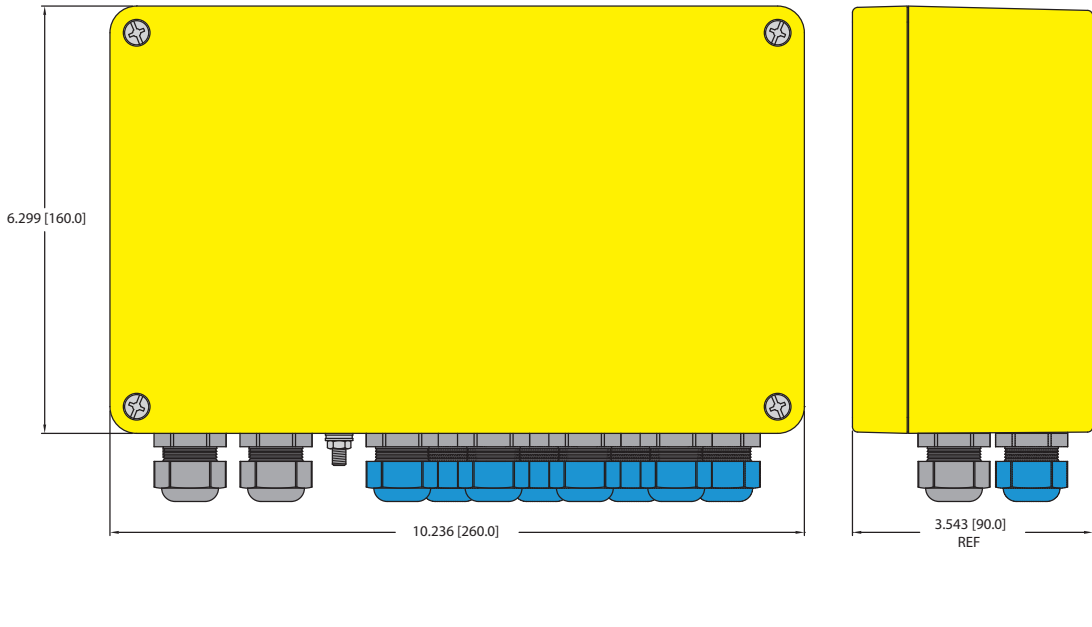
Housing Style	Part Number
 <p>5.748 [146.0]</p> <p>1.654 [42.0]</p> <p>5.217 [132.5] REF</p>	<p>RPC49-10120EX</p> <p>RPC49-10265EX</p>
 <p>6.299 [160.0]</p> <p>10.236 [260.0]</p> <p>3.543 [90.0] REF</p>	<p>MBD40-T0415/EX/000</p> <p>MBD40-T0815/EX/000</p>

# DISTRIBUTED I/O SALES GUIDE



Protocol	Description	Segments	Connectors	Relay Output	Temperature
FISCO	FISCO Power Supply	6	Removable Terminal Blocks	NA	-40...+70°C
FISCO	FISCO Power Supply	12	Removable Terminal Blocks	NA	-40...+70°C
Foundation Fieldbus, PROFIBUS PA, FISCO	Multibarrier	4	Cable glands	NA	-20...+70°C
Foundation Fieldbus, PROFIBUS PA, FISCO	Multibarrier	8	Cable glands	NA	-20...+70°C



FOUNDATION fieldbus™ Media

# IN-CABINET MODULAR I/O

**Notes:**

# PROFIBUS® –DP Physical Media Connectivity

<b>PROFIBUS-DP Cable</b>	<b>H127</b>
<b>Cordsets</b>	<b>H128</b>
<b>Receptacles</b>	<b>H135</b>
<b>Field Wireables</b>	<b>H139</b>

## Features

- Cables that meet the requirements of EN 50170 for communication up to 12 MBAUD
- PLTC rated cable (CSA FT4)
- Oil RES II and sunlight resistant
- M12 reverse keyed connectors
- Up to 4A and 250V rated
- IP67/IP69K rated

# NETWORK WIRING

## PROFIBUS®-DP, Cable Specifications

- Cable that Meets the Requirements of EN50170-2-2:1996 for Communications Up to 12 Mbaud

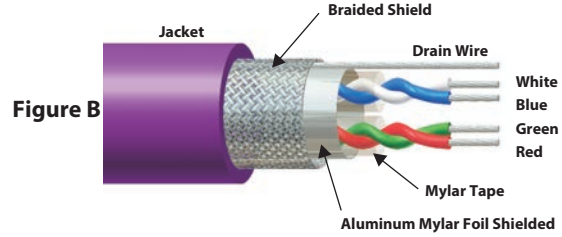
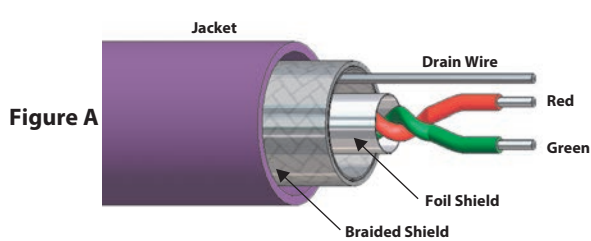

Baud Rate (k baud)	9.6	19.2	93.75	187.5	500	1500	1200
Maximum Trunk Length	1200 meters	1200 meters	1200 meters	1000 meters	400 meters	200 meters	100 meters

Type	Approvals	Data Pair		2nd Data Pair		Outer Jacket	Shields	Bulk Cable Part Number / Weight/300 M	Figure
		AWG Color Code	DCR (/1000 feet) Insulation	AWG Color Code	DCR (/1000 feet) Insulation	Material Color Nominal O.D.	Type Drain Wire		
<b>455</b> AWM 2464 80°C 300 Volts, Stranded	NEC PLTC ER DB CEC AWM-I/II A/B FT4	2/22 AWG RD/GN	16.5 Ohms PE	None	N/A	PVC Purple 8.5 mm (.335 in)	Foil/Braid 22 AWG	RB50672-*M 62 lbs.	A
<b>456</b> AWM 20233 80°C 300 Volts, Stranded	NEC AWM CEC AWM-I/II A/B	2/22 AWG RD/GN	16.5 Ohms PE	None	N/A	TPU Purple 7.9 mm (.310 in)	Foil/Braid 22 AWG	RB50683-*M 48 lbs.	A
<b>457</b> 80°C 600 Volts, Solid	NEC CMX	2/22 AWG RD/GN solid	16.5 Ohms PE	None	N/A	TPU Purple 7.8 mm (.307 in)	Foil/Braid No Drain	RB50708-*M 51 lbs.	A
<b>458</b> AWM 20233 80°C 300 Volts, Stranded	NEC AWM CEC AWM-I/II A/B	2/22 AWG RD/GN	16.5 Ohms PE	None	N/A	TPU Plum 8.5 mm (0.335 in)	Foil/Braid 22 AWG	RB50692-*M 58 lbs. <i>flexlife</i> ®	A
<b>4511</b> AWM 2464 80°C 300 Volts, Stranded	NEC PLTC CEC AWM-I/II A/B FT4	2/22 AWG RD/GN	16.5 Ohms PE	None	N/A	PVC Purple 8.5 mm (.319 in)	Foil/Braid 22 AWG	RB50881-*M 64 lbs. <i>flexlife</i>	A
<b>4515</b> 80°C 300 Volts, Stranded	IEC-60332-3 IEC-60754-1 EN 50267-2-2	2/22 AWG RD/GN	16.5 Ohms PE	None	N/A	TPU Purple 7.5 mm (0.295 in)	Foil/Braid 22 AWG	RB51225-*M 42 lbs. <b>Halogen-Free</b> ††	A
<b>590</b> AWM 2464 80°C 300 Volts, Stranded	NEC AWM	2/22 AWG RD/GN	16.5 Ohms PE	2/22 AWG BU/WH	16.5 Ohms PE	PVC Purple 8.4 mm (.330 in)	Foil/Braid 22 AWG	RB51057-*M 75 lbs.	B

\* Indicates length in meters.





Standard spool lengths are 30, 75, 100, 150, 200, 225, 300 meters.

†† Zero Halogen: to DIN VDE 0472 part 815 + IEC 60754-1

# DISTRIBUTED I/O SALES GUIDE

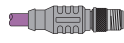
## PROFIBUS<sup>®</sup>-DP, (M12x1) *euofast*<sup>®</sup> Cable and Cordset Selection Matrix

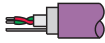

		<i>euofast</i>			
		Pin (Male)		Socket (Female)	
		 1 RSSW	 2 WSSW	 3 RKSW	 4 WKSW
 Bare		RSSW 45x-*M	WSSW 45x-*M	RKSW 45x-*M	WKSW 45x-*M
<i>euofast</i>	Pin (Male)				
	1 RSSW	RSSW RSSW 45x-*M	RSSW WSSW 45x-*M	RSSW RKSW 45x-*M	RSSW WKSW 45x-*M
	2 WSSW		WSSW WSSW 45x-*M	WSSW RKSW 45x-*M	WSSW WKSW 45x-*M
	3 RKSW			RKSW RKSW 45x-*M	RKSW WKSW 45x-*M
4 WKSW				WKSW WKSW 45x-*M	



See page H129 for dimensional drawings.

\* Indicates length in meters.

x Indicates cable type.

Standard cable lengths are 1, 2, 4, 6, 8, 10, 15, and in +5 meter increments from there. Consult factory for other lengths.  
For stainless steel coupling nuts change part number RSSW...RSSWV.

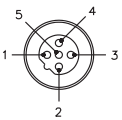
### Pinouts

<i>euofast</i>	45 series pinout	59 series pinout	<i>euofast</i>
<b>Male</b> 	1. N/C 2. Green (TxD) 3. N/C 4. Red (RxD) 5. Bare (Shield Drain Wire)	1. Blue (TxD_1) 2. Green (TxD) 3. White (RxD_1) 4. Red (RxD) 5. Bare (Shield Drain Wire)	<b>Female</b> 

# NETWORK WIRING

## PROFIBUS®-DP, (M12x1) eurofast® Cable and Cordsets

### Specifications

<b>Overmold:</b>	TPU
<b>Coupling Nut:</b>	Nickel Plated CuZn or Stainless Steel
<b>Contact Carrier:</b>	TPU or POM (Nylon)
<b>Contacts:</b>	Gold Plated CuZn
<b>Protection:</b>	NEMA 1, 3, 4, 6P and IEC IP 68
<b>Rated Voltage:</b>	250 V
<b>Rated Current:</b>	4 A
<b>Ambient Temperature:</b>	-40° to +75°C (-22° to +167°F)

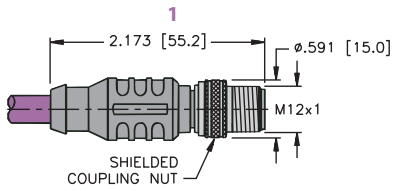

RSSW ..

Page H128

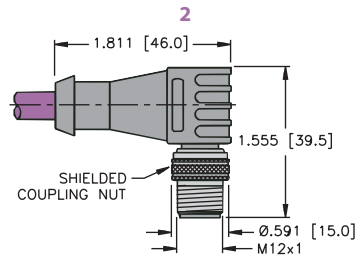

WSSW ..

Page H128

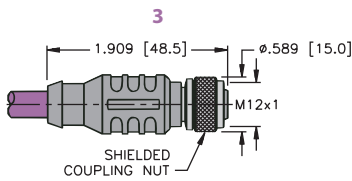

RKSU ..

Page H128

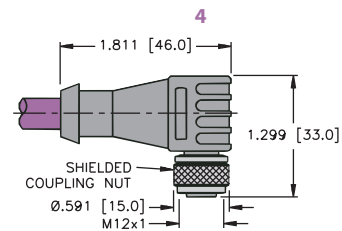

WKSU ..

Page H128

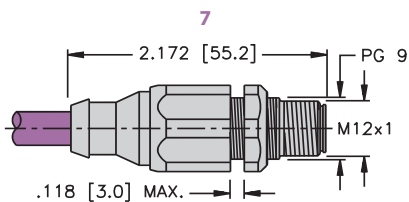





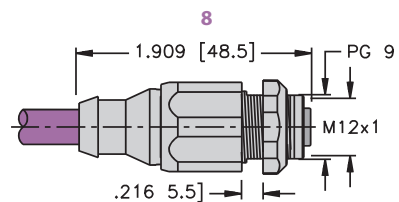

FSSDWE ..

Page H128



FKSDWE ..

Page H128

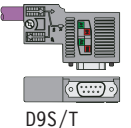
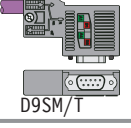
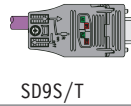
		<i>euofast</i>							
		Pin (Male)		Socket (Female)		Pin (Male)	Socket (Female)		
		 1 RSSW	 2 WSSW	 3 RKSW	 4 WKSX	 7 FSSDWE	 8 FKSDWE		
<b>9-Pin Sub D Connector</b>	<b>Terminator</b>	 10 D9S/T	D9S/T 45x-*M	RSSW D9S/T 45x-*M	WSSW D9S/T 45x-*M	RKSW D9S/T 45x-*M	WKSX D9S/T 45x-*M	FSSDWE D9S/T 45x-*M	FKSDWE D9S/T 45x-*M
	<b>Master</b>	 12 D9SM/T	D9SM/T 45x-*M	RSSW D9SM/T 45x-*M	WSSW D9SM/T 45x-*M	RKSW D9SM/T 45x-*M	WKSX D9SM/T 45x-*M	FSSDWE D9SM/T 45x-*M	FKSDWE D9SM/T 45x-*M
	 11 SD9S/T	SD9S/T 45x-*M	RSSW SD9S/T 45x-*M	WSSW SD9S/T 45x-*M	RKSW SD9S/T 45x-*M	WKSX SD9S/T 45x-*M	FSSDWE SD9S/T 45x-*M	FKSDWE SD9S/T 45x-*M	

See page H129 and H133 for dimensional drawings.

\* Indicates length in meters.

x Indicates cable type.

Standard cable lengths are 1, 2, 4, 6, 8, 10, 15, and in +5 meter increments from there. Consult factory for other lengths.

For stainless steel coupling nuts change part number RSSW...RSSWV.

### Extension Example:

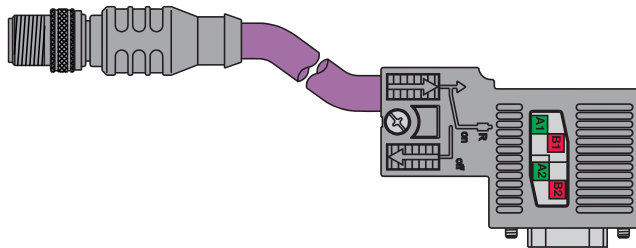





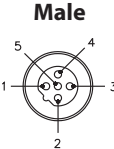
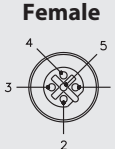
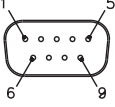

RSSW D9S/T 455-0.3M



### Pinouts

<i>euofast</i>	45 series pinout	<i>euofast</i>	D9	D9 pinout
<p><b>Male</b></p> 	<p>1. N/C 2. Green (TxD) 3. N/C 4. Red (Rx/D) 5. Bare (Shield Drain Wire)</p>	<p><b>Female</b></p> 	<p><b>Male</b></p> 	<p>1 = N/C 2 = N/C 3 = RD (RXD) 4 = N/C 5 = N/C 6 = N/C 7 = N/C 8 = GN (TXD) 9 = N/C</p>

# NETWORK WIRING

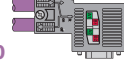
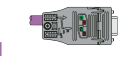
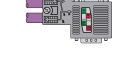
## PROFIBUS<sup>®</sup>-DP, (M12x1) eurofast<sup>®</sup> Cable and Cordset Selection Matrix

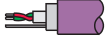
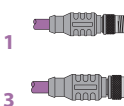
		eurofast						
		Pin (Male)		Socket (Female)		Pin (Male)	Socket (Female)	
								
		Bare	1 RSSW	2 WSSW	3 RKSW	4 WKSX	7 FSSDWE	8 FKSDWE
Straight	 Node 10 D9S	D9S 45x-*M	RSSW D9S RSSW 45x-*M-*M	WSSW D9S WSSW 45x-*M-*M	RKSW D9S RKSW 45x-*M-*M	WKSX D9S WKSX 45x-*M-*M	FSSDWE D9S FSSDWE 45x-*M-*M	FKSDWE D9S FKSDWE 45x-*M-*M
	 Node 11 SD9S	SD9S 45x-*M	RSSW SD9S RSSW 45x-*M-*M	WSSW SD9S WSSW 45x-*M-*M	RKSW SD9S RKSW 45x-*M-*M	WKSX SD9S WKSX 45x-*M-*M	FSSDWE SD9S FSSDWE 45x-*M-*M	FKSDWE SD9S FKSDWE 45x-*M-*M
	 Node 12 D9SM	D9SM 45x-*M	RSSW D9SM RSSW 45x-*M	WSSW D9SM WSSW 45x-*M-*M	RKSW D9SM RKSW 45x-*M-*M	WKSX D9SM WKSX 45x-*M-*M	FSSDWE D9SM FSSDWE 45x-*M-*M	FKSDWE D9S FKSDWE 45x-*M-*M

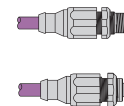
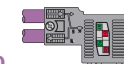
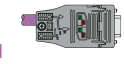
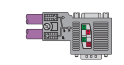
		eurofast			
		Pin (Male)		Socket (Female)	
					
		Bare	1 RSSW/RKSW	2 WSSW/WKSX	7 FSSDWE/FKSDWE
Straight	 Node 10 D9S	D9S 45x-*M	RSSW D9S RKSW 45x-*M-*M	WSSW D9S WKSX 45x-*M-*M	FSSDWE D9S FKSDWE 45x-*M-*M
	 Node 11 SD9S	SD9S 45x-*M	RSSW SD9S RKSW 45x-*M-*M	WSSW SD9S WKSX 45x-*M-*M	FSSDWE SD9S FKSDWE 45x-*M-*M
	 Node 12 D9SM	D9SM 45x-*M	RSSW D9SM RKSW 45x-*M-*M	WSSW D9SM WKSX 45x-*M-*M	FSSDWE D9SM FKSDWE 45x-*M-*M

See page H129 and H132-H133 for dimensional drawings.

\* Indicates length in meters.

x Indicates cable type.

Standard cable lengths are 1, 2, 4, 6, 8, 10, 15, and in +5 meter increments from there. Consult factory for other lengths.

For stainless steel coupling nuts change part number RSSW...RSSWV.

See previous page for pinouts.

# DISTRIBUTED I/O SALES GUIDE

## PROFIBUS®-DP, Field Wireable D9 Connectors



- Provides Connection to Master or Node in the field
- Maximum Cable O.D. is 8.5 mm

Housing Style	Part Number	Features	Pinouts
	Connector, PDP, D9S	-25° to +80°C, right angle, terminating switch	<ol style="list-style-type: none"> <li>1. N/C</li> <li>2. N/C</li> <li>3. RED (Bus_B)</li> <li>4. N/C</li> <li>5. N/C</li> <li>6. N/C</li> <li>7. N/C</li> <li>8. Green (Bus_A)</li> <li>9. N/C</li> </ol> <p style="text-align: center;"><b>Male</b></p>
	Connector, PDP, SD9S	-25° to +80°C, straight, terminating switch	
	Connector, PDP, D9SM	-25° to +80°C, right angle, master, terminating switch	

# NETWORK WIRING

## PROFIBUS® -DP, Field Wireable D9 Connectors

### Specifications - (D9)

<b>Terminating Switch:</b>	Yes
<b>Protection:</b>	IEC IP 20
<b>Rated Voltage:</b>	4.75-5.25 VDC
<b>Rated Current:</b>	5 mA
<b>Temperature Rating:</b>	-25° to +60°C

\*Max. Cable diameter: 8.5 mm

### Specifications (FKSDWE .. FSPDWE)

<b>Overmold:</b>	TPU
<b>Coupling Nut:</b>	Nickel Plated CuZn or Stainless Steel
<b>Contact Carrier:</b>	TPU or POM (Nylon)
<b>Contacts:</b>	Gold Plated CuZn
<b>Protection:</b>	NEMA 1, 3, 4, 6P and IEC IP 67
<b>Rated Voltage:</b>	250 V
<b>Rated Current:</b>	4 A
<b>Temperature Rating:</b>	-40° to +75°C

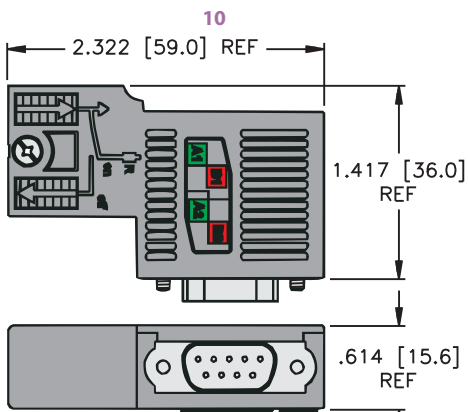

Connector, PDP, D9S

Page H130

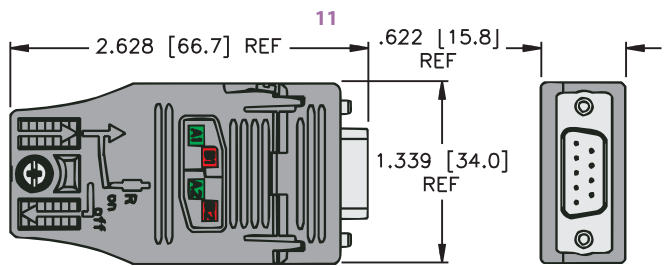

Connector, PDP, SD9S

Page H130

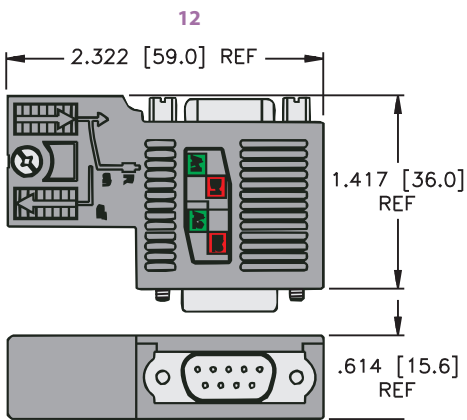

Connector, PDP, D9SM

Page H130

Note: Part numbers are for ordering connector only.  
Cable must be ordered separately.

# DISTRIBUTED I/O SALES GUIDE

## PROFIBUS<sup>®</sup>-DP, Terminating Resistors



- Terminating Resistors Stabilize and Minimize Reflections on the Bus Line
- A Terminating Resistor is Required at the Beginning and End of the Main Bus Line



Housing Style	Part Number	Features	Pinouts
	RSSW 45-TR	Nickel plated brass, 250 V, 4 A, -40° to +75°C, internal resistor, male <b>euromast</b> connector, reverse keyed	<ol style="list-style-type: none"> <li>1. N/C</li> <li>2. GN</li> <li>3. N/C</li> <li>4. RD</li> <li>5. BARE</li> </ol> <p>See Below</p>
	RKSX 45-TR	Nickel plated brass, 250 V, 4 A, -40° to +75°C, internal resistor, female <b>euromast</b> connector, reverse keyed	<ol style="list-style-type: none"> <li>1. N/C</li> <li>2. GN</li> <li>3. N/C</li> <li>4. RD</li> <li>5. BARE</li> </ol> <p>See Below</p>
	PDP-TRA	Nickel plated brass, 250 V, 4 A, -40° to +75°C, active terminating resistor, external power supply <b>minifast</b> <sup>®</sup> and <b>euromast</b> connector, LED signal for power status	<ol style="list-style-type: none"> <li>1. N/C</li> <li>2. BUS_A</li> <li>3. N/C</li> <li>4. BUS_B</li> <li>5. N/C</li> </ol> <p>See Below</p>
			<p><b>Male</b></p> <ol style="list-style-type: none"> <li>1. N/C</li> <li>2. GND</li> <li>3. N/C</li> <li>4. U<sub>i</sub>=24 VDC</li> <li>5. N/C</li> </ol>

Pinout Diagram, RSSW 45-TR

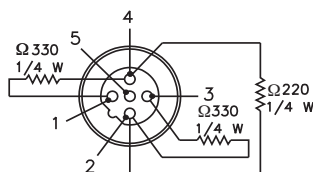

**euromast** Male Connector

Pinout Diagram, RKSX 45-TR

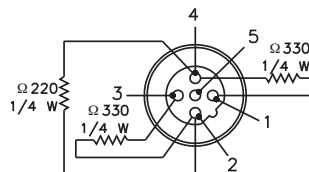

**euromast** Female Connector

Pinout Diagram, PDP-TRA

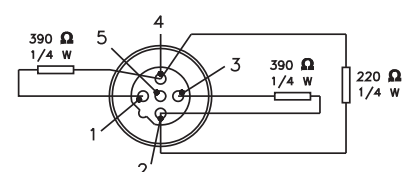

**euromast** Male Connector

# NETWORK WIRING

## PROFIBUS®-DP, Circuit Board Connectors and OEM Receptacles

- Provides (M12x1) *eurofast*® Connection to Field Devices



Housing	Female Part Number	Male Part Number	Application	Pinouts
<p><b>FKFDW 45..</b></p>	FKFDW 45-PCB	FSFDW 45-PCB	Nickel plated CuZn or stainless Steel, 250 V, 4 A, -40° to +75°C, male <i>eurofast</i> PCB pins	<p><b>Female</b></p>
<p><b>FSFDW 45..</b></p>				
<p><b>FKFDLW 45..</b></p>	FKFDLW 45	FSFDLW 45	Nickel plated CuZn or stainless Steel, 250 V, 4 A, -40° to +75°C, male <i>eurofast</i> solder cups	<ol style="list-style-type: none"> <li>1. N/C</li> <li>2. GN</li> <li>3. N/C</li> <li>4. RD</li> <li>5. BARE</li> </ol>
<p><b>FSFDLW 45..</b></p>				
<p><b>WFSW 45..</b></p>		WFSW 45-PCB	Nickel plated CuZn or stainless Steel, 250 V, 4 A, -40° to +75°C, male <i>eurofast</i> right angle PCB pins	<p><b>Male</b></p>

Standard housing material is nickel plated brass "FKFD .."; "FKFDV .." indicates 316 stainless steel.

**Panel Cutout**  
FKFD ... FSFD

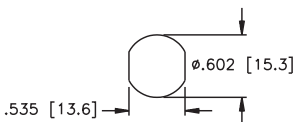

**Board Layout (reference only)**  
FKFD ... FSFD

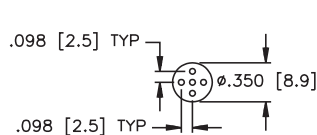

**Panel Cutout**  
WFS

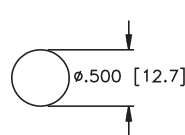

**Board Layout (reference only)**  
WFS

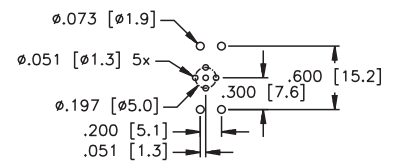

# DISTRIBUTED I/O SALES GUIDE

## PROFIBUS®-DP, Circuit Board Connectors and OEM Receptacles



- Provides (M12x1) eurofast® Connection to Field Devices



Housing	Female Part Number	Male Part Number	Application	Pinouts
<p><b>FKW 45 PCB KIT</b></p> <p><b>FSW 45 PCB KIT</b></p>	FKW 45-PCB KIT	FSW 45-PCB KIT	Nickel plated CuZn or stainless steel, 250 V, 4 A, -30° to +75°C, male eurofast with mounting kit, Reverse key	<p><b>Female</b></p> <p>1. N/C 2. GN 3. N/C 4. RD 5. BARE</p> <p><b>Male</b></p>
<p><b>FK 45 PCB</b></p> <p><b>FSW 45 PCB</b></p>	FK 45-PCB	FSW 45-PCB		

Standard housing material is nickel plated brass "FKFD .."; "FKFDV .." indicates 316 stainless steel.

### Board Layout (reference only) FK ... FS

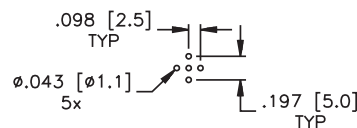

# NETWORK WIRING

## PROFIBUS<sup>®</sup>-DP, *euofast*<sup>®</sup> Feed Through Receptacle

- Provides Bulkhead Panel Mount Connection



Housing Style	Part Number	Features	Pinouts
<p>M12x1 LOCKNUT LN-M12 LOCKWASHER LW-M12</p>	<p><b>FKW FSW 45/M12</b></p>	<p>Nickel plated brass or stainless steel, 250 V, 4 A, -40° to +75°C, straight male/female connector, for pre-molded reverse keyed <i>euofast</i> cables</p>	

For stainless steel change part number to FKWV FSWV 45/M12

# DISTRIBUTED I/O SALES GUIDE

## PROFIBUS®-DP, *euromast*® Bus Tees

- Creates a Branch from the Main Bus Line



Housing Style	Part Number	Features	Wiring Diagrams
	RКСW 2RSSW 45	TPU, Nickel plated brass, 250 V, 4 A, -40° to +75°C, male <i>euromast</i> drop connector, fully shielded <i>euromast</i> tee, passive termination	
	* RКСW 2RSSW 45-0001	TPU, Nickel plated brass, 250 V, 4 A, -40° to +75°C, Male <i>euromast</i> connector, fully shielded <i>euromast</i> tee	
	VB2/FSW/FKW/FSW 45	TPU, Nickel plated brass, 250 V, 4 A, -40° to +75°C, Y Junction, fully shielded <i>euromast</i> connectors	
	YB22-FSW/FKW/FSW 45	TPU, Nickel plated brass, 250 V, 4 A, -40° to +75°C	
	YB22-FKM/FKW/FSW 45	TPU, Nickel plated brass, 250 V, 4 A, -40° to +75°C	

### Pinouts

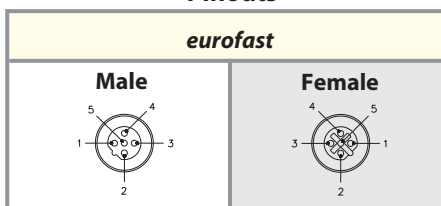

# NETWORK WIRING

## PROFIBUS®-DP, eurofast® Field Wireable Connectors with Labels

- Allows for Quick Connection when Pre-Molded Cables not Available
- Available for Male and Female Connectors
- Color Coded Wire Connection for PROFIBUS-DP



Housing Style	Female Part Number	Male Part Number	Features	Pinouts
<p><b>BMWS 81..</b></p> <p><b>BMSWS 81..</b></p>	<b>BMWS 8151-8.5/PDP</b>	<b>BMSWS 8151-8.5/PDP</b>	Nickel plated brass, cable gland, accepts 6-8.5 mm cable diameter, screw terminals, accepts up to 18 AWG conductors, -25° to +85°C, 125 V, 4 A, mates with reverse key, 5-pin cordsets and receptacles, metal, fully shielded, IP67	<p><b>Female</b></p> <p><b>Male</b></p>
<p><b>BMWS 82..</b></p> <p><b>BMSWS 82..</b></p>	<b>BMWS 8251-8.5/PDP</b>	<b>BMSWS 8251-8.5/PDP</b>		

---

<b>Cordsets</b>	<b>H143</b>
<b>Receptacles</b>	<b>H147</b>
<b>Tees</b>	<b>H152</b>
<b>Field Wireables</b>	<b>H155</b>
<b>Adapters/Junctions</b>	<b>H158</b>

---

## Features

- Cable that meets the requirements of ISA/SP 50 and PROFIBUS-PA requirements for Type A Cable
- All cables are rated -40° to +105° and are sunlight resistant
- Available in 3-wire versions with a device ground or 2-wire versions
- PLTC and ITC listed (CSA FTA)
- Exposed Run (ER) and Direct Burial listed
- IP67 Rated

# NETWORK WIRING

Notes:

## PROFIBUS®-PA, Cable Specifications

- Cable that Meets the Requirements of ISA/SP50 and PROFIBUS-PA Requirements for Type A Cable
- All Cables are Rated -40° to +105°C and are Sunlight Resistant
- Available in 3-wire Versions with a Device Ground or 2-wire Versions

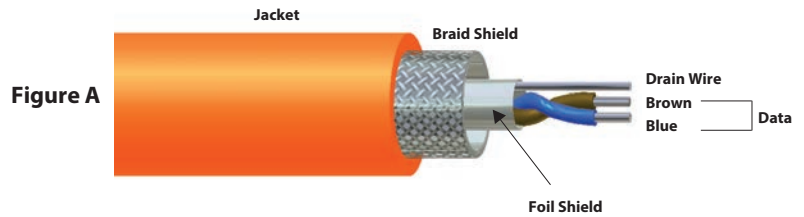

### Type A Cable Specifications

- Temperature range: -40 to +105°C
- UV Resistant
- PLTC and ITC Listed (CSA FT4)
- Exposed Run (ER) and Direct Buried (DB) Listed
- Maximum Attenuation at 1.25 f<sub>r</sub> (39 kHz) = 3.0 dB/km
- Characteristic Impedance 100 Ω ± 10 Ω @ 31.25 KHz
- Capacitance: 20 pF/Ft nominal
- Inductance: 0.22 μH/Ft. nominal
- Conductor Cross-sectional area (wire size) = nominal 0.75 mm<sup>2</sup> (#18 AWG) or 1.5 mm<sup>2</sup> (#16 AWG)
- Shield Coverage =100 %

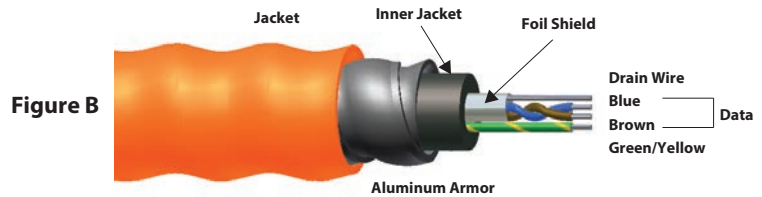



Type	Approvals	Data Pair		Device Ground	Outer Jacket	Shields	Bulk Cable Part Number / Weight/300 M	Figure
		AWG Color Code	DCR (/1000 feet) Insulation					
<b>483</b> 105°C 300 Volts	NEC/UL ITC PLTC Exposed Run, Direct Burial, CEC/CSA [CMG] HLABCD	2/18 AWG BU/BN	7.06 Ohms XLPE	None	PVC Orange 8.5 mm (.335 in)	Foil/Braid 20 AWG	RB50785-*M 59 lbs.	A
<b>483B</b> 105°C 300 Volts	NEC ITC PLTC Open Wiring, Direct Burial CEC [CMG] AWM I/II A/B FT4	2/18 AWG BU/BN	7.06 Ohms XLPE	None	PVC Blue 8.5 mm (.335 in)	Foil/Braid 20 AWG	RB50786-*M 59 lbs.	A
<b>482A</b> 105°C 300 Volts	NEC/UL ITC PLTC Direct Burial	2/18 AWG BU/BN	7.06 Ohms PVC	18 AWG GN/YE	Armor/PVC Orange 15.6 mm (.614 in)	Foil 20 AWG	RB50929-*M 96 lbs.	B
<b>482BA</b> 105°C 300 Volts	NEC/UL ITC PLTC Direct Burial	2/18 AWG BU/BN	7.06 Ohms PE	18 AWG GN/YE	Armor/PVC Blue 15.6 mm (.614 in)	Foil 20 AWG	RB50803-*M 96 lbs.	B
<b>483BK</b> 105°C 300 Volts	NEC/UL ITC PLTC Exposed Run, Direct Burial, CEC/CSA [CMG] HLABCD	2/18 AWG BU/BN	7.06 Ohms PE	None	PVC Black 8.5 mm (.335 in)	Foil/Braid 20 AWG	RB50860-*M 59 lbs.	A

\* Indicates length in meters.  
Standard spool lengths are 30, 75, 100, 150, 200, 225, 300 meters.

# NETWORK WIRING

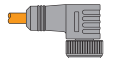
## PROFIBUS® -PA, Cable and Cordset Selection Matrix

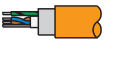
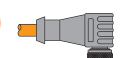
		minifast®				eurofast®	
		Pin (Male)		Socket (Female)		Pin (Male)	
		1  RSV	3  WSV	2  RKV	4  WKV	7  RSCV	
 Bare		RSV 48x-*M	WSV 48x-*M	RKV 48x-*M	WKV 48x-*M	RSCV 48x-*M	
minifast	Pin (Male)	1  RSV	RSV RSV 48x-*M	RSV WSV 48x-*M	RSV RKV 48x-*M	RSV WKV 48x-*M	RSV RSCV 48x-*M
		3  WSV		WSV WSV 48x-*M	WSV RKV 48x-*M	WSV WKV 48x-*M	WSV RSCV 48x-*M
		2  RKV			RKV RKV 48x-*M	RKV WKV 48x-*M	RKV RSCV 48x-*M
	Socket (Female)	4  WKV				WKV WKV 48x-*M	WKV RSCV 48x-*M
eurofast	Pin (Male)	7  RSCV					RSCV RSCV 48x-*M
		9  WSCV					
		8  RKCV					
	Socket (Female)	10  WKCV					

See pages H145 - H146 for dimensional drawings.

\* Indicates length in meters.

x Indicates cable type.



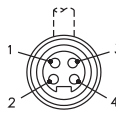
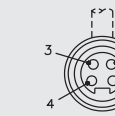
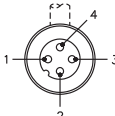
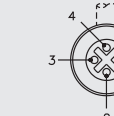

Standard cable lengths are 1, 2, 4, 6, 8, 10, 15, and in +5 meter increments from there. Consult factory for other lengths.

minifast		Pinouts	eurofast	
Male 	Female 	1. Brown (+ Voltage) 2. N/C 3. Blue (- Voltage) 4. Bare (Shield Drain Wire)	Male 	Female 

# DISTRIBUTED I/O SALES GUIDE

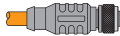
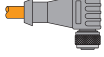
## PROFIBUS®-PA, Cable and Cordset Selection Matrix

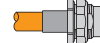

eurofast®			minifast® Bulkhead		eurofast Bulkhead	
Pin (Male)	Socket (Female)		Pin (Male)	Socket (Female)	Pin (Male)	Socket (Female)
9 	8 	10 	5 	6 	11 	12 
WSCV	RKCV	WKCVC	RSFPV	RKFPV	FSFDV	FKFDV
WSCV 48x-*M	RKCV 48x-*M	WKCVC 48x-*M	RSFPV 48x-*M	RKFPV 48x-*M	FSFDV 48x-*M	FKFDV 48x-*M
RSV WSCV 48x-*M	RSV RKCV 48x-*M	RSV WKCVC 48x-*M	RSV RSFPV 48x-*M	RSV RKFPV 48x-*M	RSV FSFDV 48x-*M	RSV FKFDV 48x-*M
WSV WSCV 48x-*M	WSV RKCV 48x-*M	WSV WKCVC 48x-*M	WSV RSFPV 48x-*M	WSV RKFPV 48x-*M	WSV FSFDV 48x-*M	WSV FKFDV 48x-*M
RKV WSCV 48x-*M	RKV RKCV 48x-*M	RKV WKCVC 48x-*M	RKV RSFPV 48x-*M	RKV RKFPV 48x-*M	RKV FSFDV 48x-*M	RKV FKFDV 48x-*M
WKV WSCV 48x-*M	WKV RKCV 48x-*M	WKV WKCVC 48x-*M	WKV RSFPV 48x-*M	WKV RKFPV 48x-*M	WKV FSFDV 48x-*M	WKV FKFDV 48x-*M
RSCV WSCV 48x-*M	RSCV RKCV 48x-*M	RSCV WKCVC 48x-*M	RSCV RSFPV 48x-*M	RSCV RKFPV 48x-*M	RSCV FSFDV 48x-*M	RSCV FKFDV 48x-*M
WSCV WSCV 48x-*M	WSCV RKCV 48x-*M	WSCV WKCVC 48x-*M	WSCV RSFPV 48x-*M	WSCV RKFPV 48x-*M	WSCV FSFDV 48x-*M	WSCV FKFDV 48x-*M
	RKCV RKCV 48x-*M	RKCV WKCVC 48x-*M	RKCV RSFPV 48x-*M	RKCV RKFPV 48x-*M	RKCV FSFDV 48x-*M	RKCV FKFDV 48x-*M
		WKCVC WKCVC 48x-*M	WKCVC RSFPV 48x-*M	WKCVC RKFPV 48x-*M	WKCVC FSFDV 48x-*M	WKCVC FKFDV 48x-*M

PROFIBUS®-PA Connectivity

# NETWORK WIRING

## PROFIBUS®-PA, minifast® Cordset and Receptacle Connector Dimensions

### Specifications

<b>Overmold:</b>	TPU
<b>Coupling Nut:</b>	Nickel Plated CuZn or Stainless Steel
<b>Contact Carrier:</b>	TPU
<b>Contacts:</b>	Gold Plated CuZn
<b>Protection:</b>	NEMA 1, 3, 4, 6P and IEC IP 68
<b>Rated Voltage:</b>	300 V
<b>Rated Current:</b>	9 A
<b>Ambient Temperature:</b>	-40°C to +105°C (-40° to +221°F)

1

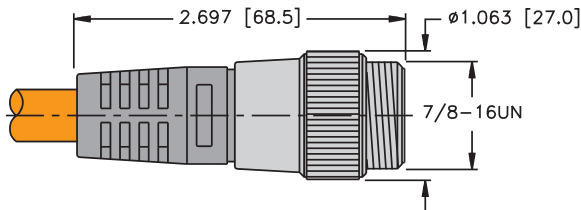

RSV ..

Pages H143

2

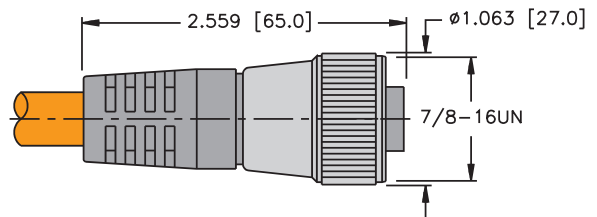

RKV ..

Pages H143

3

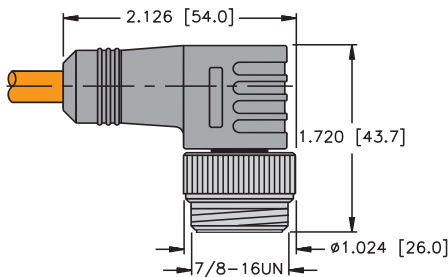

WSV ..

Pages H143

4

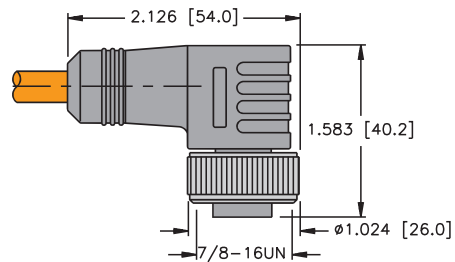

WKV ..

Pages H143

5

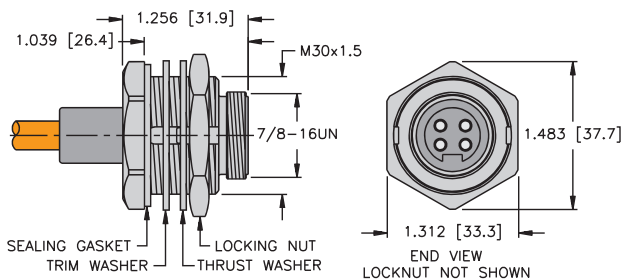

RSFPV ..

Pages H144

6

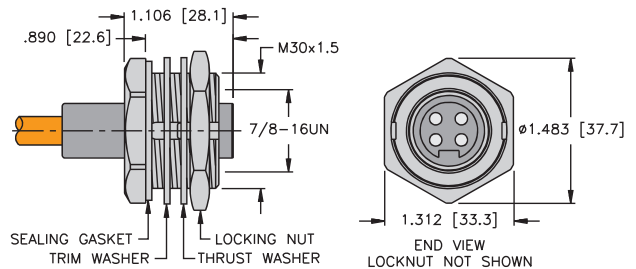

RKFPV ..

Pages H144

### Specifications

<b>Overmold:</b>	TPU
<b>Coupling Nut:</b>	Nickel Plated CuZn or Stainless Steel
<b>Contact Carrier:</b>	TPU or POM (Nylon)
<b>Contacts:</b>	Gold Plated CuZn
<b>Protection:</b>	NEMA 1, 3, 4, 6P and IEC IP 68
<b>Rated Voltage:</b>	250 V
<b>Rated Current:</b>	4 A
<b>Ambient Temperature:</b>	-40° to +105°C (-40° to +221°F)

7

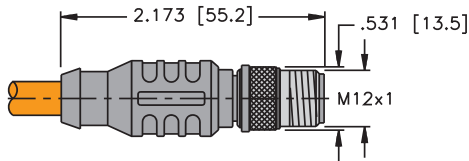

RSCV ..

Pages H143

8

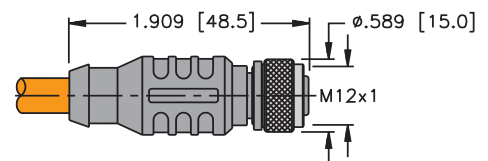

RKCVC ..

Pages H143

9

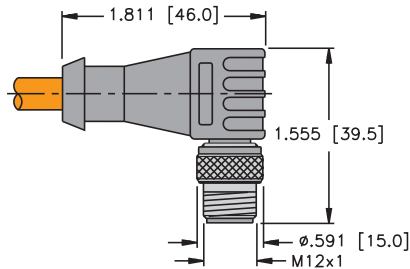

WSCV ..

Pages H143

10

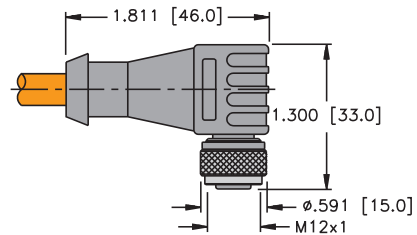

WKCVC ..

Pages H143

11

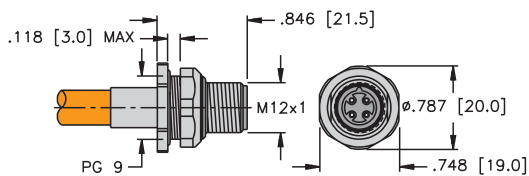

FSFDV ..

Pages H144

12

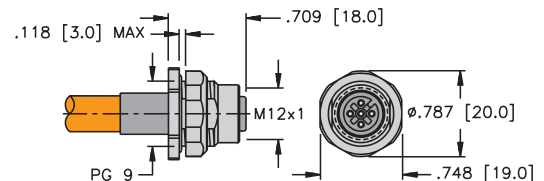

FKFDV ..

Pages H144

# NETWORK WIRING

## PROFIBUS®-PA, (7/8-16UN) minifast® Male Receptacles

- Provides Quick Connection to Field Devices
- Available for 1/2-14NPT, 1/2-14NPSM, 3/4-14NPT and M20 Threads



Housing Style	Female Part Number	Male Part Number	Features	Pinouts
<p><b>RKFV 48-*M/14.5</b></p>	RKFV 48-*M/14.5	RSFV 48-*M/14.5	Nickel Plated CuZn or Stainless Steel 600 V, 9 A -40° to +105°C 1/2-14NPT full length threads	<p><b>Female</b></p>
<p><b>RSFV 48-*M/14.5</b></p>				
<p><b>RKFV 48-*M/14.75</b></p>	RKFV 48-*M/14.75	RSFV 48-*M/14.75	Nickel Plated CuZn or Stainless Steel 600 V, 9 A -40° to +105°C 3/4-14NPT full length threads	<p>1. BN 2. N/C 3. BU 4. GY</p>
<p><b>RSFV 48-*M/14.75</b></p>				
<p><b>RKFV 48-*M/M20</b></p>	RKFV 48-*M/M20	RSFV 48-*M/M20	Nickel Plated CuZn or Stainless Steel 600 V, 9 A -40° to +105°C M20x1.5 threads	<p><b>Male</b></p>
<p><b>RSFV 48-*M/M20</b></p>				

Standard cable length is 0.5 Meters. Consult factory for other lengths.  
 Standard housing material is nickel plated brass. "RKFV .."; indicates 316 stainless steel housing.  
 For locknuts to be included, add "W/LN" to the end of the part number.

# DISTRIBUTED I/O SALES GUIDE



## PROFIBUS®-PA, (7/8-16UN) minifast® Female Receptacles

- Provides Quick Connection to Field Devices
- Available for 1/2-14NPT, 1/2-14NPSM, 3/4-14NPT and M20 Threads



Housing Style	Female Part Number	Male Part Number	Features	Pinouts
<p><b>RKFV 48-*M</b></p> <p><b>RSFV 48-*M</b></p>	RKFV 48-*M	RSFV 48-*M	<p>Nickel Plated CuZn or Stainless Steel</p> <p>600 V, 9 A</p> <p>-40° to +105°C</p> <p>1/2-14NPSM threads</p>	<p><b>Female</b></p> <p><b>Male</b></p>

Standard cable length is 0.5 Meters. Consult factory for other lengths.  
 Standard housing material is nickel plated brass. "RKFV .."; indicates 316 stainless steel housing.  
 For locknuts to be included, add "W/LN" to the end of the part number.

**Options:**

/C1117 = 4 wires (BN,GN/YE, BU, GY)

PROFIBUS®-PA Connectivity

# NETWORK WIRING

## PROFIBUS®-PA, (M12x1) eurofast® Male Receptacles

- Mounted for Quick Connection to Enclosures
- Available for 1/2-14NPT, 1/2-14NPSM, 3/4-14NPT and M20 Threads



Housing Style	Female Part Number	Male Part Number	Features	Pinouts
<p><b>FKV 48-*M/14.5</b></p> <p><b>FSV 48-*M/14.5</b></p>	FKV 48-*M/14.5	FSV 48-*M/14.5	Nickel Plated CuZn or Stainless Steel 250 V, 4 A -40° to +105°C 1/2-14NPT full length threads	<p><b>Female</b></p>
<p><b>FKV 48-*M/14.75</b></p> <p><b>FSV 48-*M/14.75</b></p>				
<p><b>FKV 48-*M</b></p> <p><b>FKV 48-*M</b></p>	FKV 48-*M/M20	FSV 48-*M/M20	Nickel Plated CuZn or Stainless Steel 250 V, 4 A -40° to +105°C M20x1.5 threads	<p><b>Male</b></p>

Standard cable length is 0.5 Meters. Consult factory for other lengths.  
 Standard housing material is nickel plated brass. "RKfV .."; indicates 316 stainless steel housing.

# DISTRIBUTED I/O SALES GUIDE

## PROFIBUS®-PA, (M12x1) eurofast® Female Receptacles



- Mounted for Quick Connection to Enclosures
- Available for 1/2-14 NPT, 1/2-14 NPSM, 3/4-14 NPT and M20 Threads

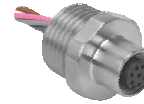

Housing Style	Female Part Number	Male Part Number	Features	Pinouts
<p><b>FKV 48-*M</b></p>	FKV 48-*M	FSV 48-*M	Nickel Plated CuZn or Stainless Steel 250 V, 4 A -40° to +105°C PG 9 threads	<ol style="list-style-type: none"> <li>1. BN</li> <li>2. N/C</li> <li>3. BU</li> <li>4. GY</li> </ol>
<p><b>FSV 48-*M</b></p>				
				<p><b>Male</b></p>

Standard cable length is 0.5 Meters. Consult factory for other lengths.  
 Standard housing material is nickel plated brass. "RKFV .."; indicates 316 stainless steel housing.

**Options:**

/C1117 = 4 wires (BN,GN/YE, BU, GY)

# NETWORK WIRING

## PROFIBUS<sup>®</sup>-PA, Terminating Resistors

- Terminating Resistors Stabilize and Minimize Reflections on the Bus Line
- A Terminating Resistor is Required at the Beginning and End of the Main Bus Line



Housing	Part Number	Features	Pinouts
	RSV 48-TR	Nickel plated brass or stainless steel, 300 V, 9 A -40° to +75°C, male <i>minifast</i> connector	<p><b>Male</b></p>
	RSEV 48-TR	Nickel plated brass or stainless steel, 250 V, 4 A -40° to +75°C, male <i>eurofast</i> connector	<p><b>Male</b></p>

## PROFIBUS<sup>®</sup>-PA, Feed Through Connectors

- Receptacles Provide Transition from Male to Female Connectors
- Available for Bulkhead and Feed Through Applications



Housing	Part Number	Features	Pinouts
	RSFV RKFV 48/22	Nickel plated CuZn or stainless steel, 300 V, 9 A, -40° to +75°C, straight male/female feed through, for use with DeviceNet <i>minifast</i> cordsets	<p><b>Male</b></p> <p><b>Female</b></p>
	FKV FSV 48/M12	Nickel plated CuZn or stainless steel, 250 V, 4 A, -40° to +75°C, straight male/female connector, for pre-molded <i>eurofast</i> cables	<p><b>Male</b></p> <p><b>Female</b></p>

Standard housing material is nickel plated brass. "RSF RKF.."; "RSFV RKFV.." indicates stainless steel housing.

**Panel Cutout**  
RSFV RKFV 48/22

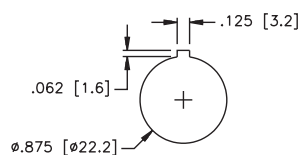

**Panel Cutout**  
FKV FSV 48/M12

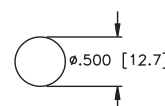

# DISTRIBUTED I/O SALES GUIDE

## PROFIBUS-PA, Tees



- Creates a Drop or Branch from the Main Bus Line
- *minifast*® Connectors on Bus or Drop Lines



Housing	Part Number	Features	Wiring Diagrams
	RSV 2RKV 48	TPU, 250 V, 4 A, -40° to +75°C, data, ground, shield, stainless steel, coupling nuts	
	RSV FKV RKV 48	TPU, 250 V, 4 A, -40° to +75°C, <i>minifast</i> to <i>eurofast</i> ® drop, data, ground, shield, stainless steel coupling nuts	
	RSCV 2RKCV 48	TPU, 250 V, 4 A, -40° to +75°C, <i>eurofast</i> tee, stainless steel, coupling nuts	
	RSCV RKCVC 48	TPU, 250 V, 4 A, -40° to +105°C, stainless steel coupling nuts	

### Pinouts

<i>minifast</i>		<i>eurofast</i>	
Male	Female	Male	Female

# NETWORK WIRING

## PROFIBUS-PA, Gender Changers and Elbow Connectors

- Allows Quick and Easy Changes from Male to Female *minifast*® and *minifast*® to *eurofast*® Connectors



Housing	Part Number	Features	Wiring
	<b>RSV RSV 48</b>	TPU, 250 V, 4 A, -40° to +75°C, changes female cordset to male receptacle	
	<b>RKV RKV 48</b>	TPU, 250 V, 4 A, -40° to +75°C, changes female cordset to male receptacle	N/A
	<b>WSV RKV 48</b>	TPU, 250 V, 4 A, -40° to +75°C, right angle male to female connector	
	<b>RSM 48-FK 4.4</b>	Nickel plated brass CuZn or Stainless Steel, 250 V, 4 A, -40° to +80°C, female <i>eurofast</i> , male <i>minifast</i> , 4-pin	

### Pinouts

<i>minifast</i>		<i>eurofast</i>
<b>Male</b> 	<b>Female</b> 	<b>Female</b> 

# DISTRIBUTED I/O SALES GUIDE



## PROFIBUS®-PA, Surge Suppressor

- Protects Data Communication Lines (V+ and V-)
- Absorbs the Front End of the Transient, Responding in Less Than a Nanosecond
- Diverts the Surge Energy to Ground
- Automatically Resets and waits for Next Surge



Housing	Part Number	Specs	Application	Pinouts
See Drawing 1	RSV RKV 48 SS	<p><b>Electrical</b></p> <p>Contact Carrier Material . . . . . Thermoplastic Polyurethane                      Mold Material/Color . . . . . Thermoplastic Polyurethane/Black                      Contact Material/Plating . . . . . Gold-Plated Brass                      Coupling Nut Material . . . . . Stainless Steel                      Max. Operating Voltage . . . . . 36 VDC                      Max. Operating Current . . . . . 600 mA                      Max. Clamping Voltage . . . . . 58 V                      Surge Current (8/20µs ≤5 shots) . . . . . 20kA                      Temperature Rating . . . . . -40° to +85°C                      Protection Class (VDE 0110 b) . . . . . Meets NEMA 1,3,4,6,13                      Insulation Resistance . . . . . ≥40 MΩ                      Capacitance Between V+, V- at 24 V . . . . . 0.4nF</p> <p><b>Mechanical</b></p> <ul style="list-style-type: none"> <li>• Ground Stud: 10-32 stainless steel</li> <li>• Operating temperature: -40° to +85°C</li> </ul>	Male and female <i>minifast</i> ®, 4-pin	<p><b>Male</b></p> <p><b>Female</b></p>

1

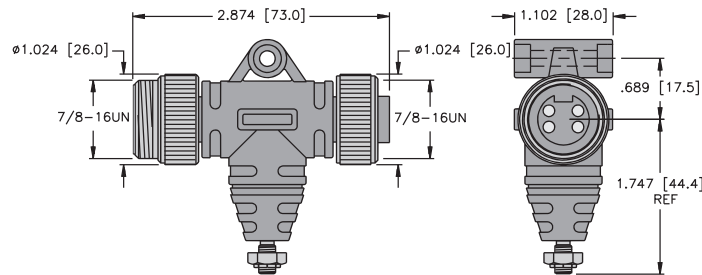

PROFIBUS®-PA Connectivity

# NETWORK WIRING

## PROFIBUS®-PA, *minifast*® Field Wireable Connectors

- Screw Terminals Accept up to 16 AWG Conductors



Housing Style	Female Part Number	Male Part Number	Features	Pinout
<p><b>B 414..</b></p>	<b>B 4140-0/9</b>	<b>BS 4140-0/9</b>	Glass filled nylon, PG 9 cable gland, accepts 6-8 mm cable diameter, 85°C, 250 V, 9 A, mates with all 4-pin <i>minifast</i> cordsets and receptacles	<p><b>Female</b></p>
<p><b>BS 414..</b></p>	<b>B 4141-0/13.5</b>	<b>BS 4141-0/13.5</b>	Glass filled nylon, PG 13.5 cable gland accepts 10-12 mm cable diameter, 85°C, 250 V, 9 A, mates with all 4-pin <i>minifast</i> cordsets and receptacles	<p><b>Male</b></p>

For stainless steel coupling nuts change part number BS ... to BSV ... BK ... To BV

# DISTRIBUTED I/O SALES GUIDE

## PROFIBUS®-PA, *minifast*® Field Wireable Connectors



- Screw Terminals Accept up to 16 AWG Conductors

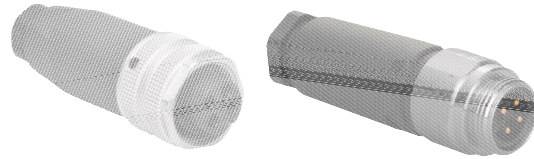

Housing Style	Female Part Number	Male Part Number	Features	Pinout
<p><b>BK 414..</b></p>	BK 4140-0/9	BS 4140-0/9	Plastic, TPU (cable grip: Plastic, PU), Anodized Aluminum, PG 0/9 cable gland accepts 6-8 mm cable diameter, -40°C to +90°C (-40°F to +194°F), 250 V, 9 A, mates with all 4-pin <i>minifast</i> cordsets and receptacles	<p><b>Female</b></p>
<p><b>BS 414..</b></p>				
<p><b>BSV 414..</b></p>	BKV 4140-0/9	BSV 4140-0/9	Glass filled nylon, stainless steel coupling nut, PG 0/9 cable gland accepts 6-8 mm cable diameter, -40°C to +90°C (-40°F to +194°F), 300 V, 9 A, mates with all 4-pin <i>minifast</i> cordsets and receptacles	<p><b>Male</b></p>
<p><b>BKV 414..</b></p>				
<p><b>BKV 414..</b></p>	BKV 4140-0/16	BSV 4140-0/16	Glass filled nylon, stainless steel coupling nut, PG 16 cable gland accepts 10-12 mm cable diameter, -40°C to +90°C (-40°F to +194°F), 600 V, 9 A, mates with all 4-pin <i>minifast</i> cordsets and receptacles	
<p><b>BSV 414..</b></p>				

PROFIBUS®-PA Connectivity

# NETWORK WIRING

## PROFIBUS<sup>®</sup>-PA, *eurofast*<sup>®</sup> Field Wireable Connectors

- Screw Terminals Accept up to 18 AWG Conductors



Housing	Female Part Number	Male Part Number	Features	Pinouts
<p><b>B 814..</b></p> <p><b>BS 814..</b></p>	B 8141-0/PG9	BS 8141-0/PG9	PBT, Black, PG 9 cable gland, accepts 4-8 mm cable diameter, 85°C, 125 V, 4 A, mates with standard key 4-pin <i>eurofast</i> cordsets and receptacles	<p><b>Female</b></p>
<p><b>B 824..</b></p> <p><b>BS 824..</b></p>				B 8241-0/PG9

# DISTRIBUTED I/O SALES GUIDE



## PROFIBUS®-PA, Conduit Adapters

- Converts Standard Conduits to Quick Disconnect
- Fiberglass Reinforced Nylon Housings
- Nickel Plated Brass Connectors Available
- 3/4" Form 8 or Mark 9
- 1" Form 7 Available Upon Request
- Gasket and Mounting Screws Provided
- IP67



Housing Style	1 Port Part Number	2 Port Part Number	Specifications	Pinouts
	BCA-48-E123	BCA-48-E223	M12x1 Stainless Steel Connectors, switchable termination, -40°C to +70°C (-40°F to +158°F)	
	BCA-48-M123	BCA-48-M223	7/8"-16UN Stainless Steel Connectors, switchable termination, -40°C to +70°C (-40°F to +158°F)	
	BCA-48SC-M123	BCA-48SC-M223	7/8"-16UN Stainless Steel Connectors, short circuit protection, switchable termination, -30°C to +80°C (-22°F to +176°F)	



PROFIBUS Media

# NETWORK WIRING

## PROFIBUS®-PA, On-Machine Passive Junction Boxes

- Multiple Port Configurations Available
- Cast aluminum Housing\*
- 7/8" x 1 Bus In/Bus Out Connectors\*
- Nickel Plated Brass Connectors Available
- CSA General Purpose
- -40°C to +75°C (-40°F to +167°F)
- IP67, IP68 and IP69k

\*(Unless otherwise specified)



Housing Style	Part Number	Specifications	Pinouts
	JBBS-48-E613	M12x1 Bus-in/Bus-out plus 6 drops	
	JBBS-48-E813	M12x1 Bus-in/Bus-out plus 8 drops	
	JBBS-48-M613	7/8"-16UN Bus-in/Bus-out plus 6 drops	
	JBBS-48-M813	7/8"-16UN Bus-in/Bus-out plus 8 drops	
	JBBS-48SC-E413	M12x1 Bus-in/Bus-out plus 4 drops, short circuit protection	
	JBBS-48SC-E613	M12x1 Bus-in/Bus-out plus 6 drops, short circuit protection	
	JBBS-48SC-E813	M12x1 Bus-in/Bus-out plus 8 drops, short circuit protection	
	JBBS-48SC-M413	7/8"-16UN Bus-in/Bus-out plus 4 drops, short circuit protection	
	JBBS-48SC-M613	7/8"-16UN Bus-in/Bus-out plus 6 drops, short circuit protection	
	JBBS-48SC-M813	7/8"-16UN Bus-in/Bus-out plus 8 drops, short circuit protection	

# DISTRIBUTED I/O SALES GUIDE



Industrial Automation

## PROFIBUS®-PA, On-Machine Passive Junction Boxes

- Multiple Port Configurations Available
- Cast aluminum Housing\*
- 7/8" x 1 Bus In/Bus Out Connectors\*
- Nickel Plated Brass Connectors Available
- CSA General Purpose
- -40°C to +75°C (-40°F to +167°F)
- IP67

\*(Unless otherwise specified)



Housing Style	Part Number	Specifications	Pinouts
	<b>JBBS-48SC-M853</b>	7/8"-16UN Bus-in/Bus-out plus 8 drops, cast stainless steel housing, short circuit protection, CE	
	<b>JBBS-48SC-M653</b>	7/8"-16UN Bus-in/Bus-out plus 6 drops, cast stainless steel housing, short circuit protection, CE	
	<b>JBBS-48-E413</b>	M12x1 Bus-in/Bus-out plus 4 drops	
	<b>JBBS-48-M413</b>	7/8"-16UN Bus-in/Bus-out plus 4 drops	



PROFIBUS Media

# NETWORK WIRING

## PROFIBUS®-DP, Wall Plate Adapters

- Attaches to Standard Single Gang Electrical Box
- Stainless Steel with Stainless Steel Connectors
- Gasket and Mounting Screws Provided
- IP67



Housing Style	Part Number	Specifications	Pinouts
<p>4.689 [119.1] REF 3.281 [83.3] 2.951 [75.0] .625 [15.9] REF</p>	<p><b>BPA-45-E113</b></p>	<p>PROFIBUS-DP, M12x1 Connector, -40°C to +70°C (-40°F to +158°F)</p>	<p>4 5 3 1 2</p>

# DISTRIBUTED I/O SALES GUIDE



## PROFIBUS®-DP/PA, Conduit Adapters

- Converts Standard Conduits to Quick Disconnect
- Fiberglass Reinforced Nylon Housings
- Nickel Plated Brass Connectors Available
- 3/4" Form 8 or Mark 9
- 1" Form 7 Available Upon Request
- Gasket and Mounting Screws Provided
- IP67



Housing Style	1 Port Part Number	2 Port Part Number	Specifications	Pinouts
	BCA-45-E123	BCA-45-E223	PROFIBUS-DP, M12x1 stainless steel connectors, -30°C to +80°C (-22°F to +176°F)	



PROFIBUS Media

# NETWORK WIRING

Notes:

# AS-interface® Physical Media Connectivity

---

<b>Cordsets</b>	<b>H167</b>
<b>Receptacles</b>	<b>H174</b>
<b>Field Wireables</b>	<b>H178</b>
<b>Adapters/Junctions</b>	<b>H181</b>

---

## Features

- Cables that meet the requirements of EN 50295 for communication up to 167 KBAUD
- ITC-ER/PLTC-ER rated cable (CSA FT4)
- Oil resistant II and sunlight resistant
- 7/8 and M12 connectors
- Up to 9 Amps and 600 Volt rated
- IP67/IP69K rated

# NETWORK WIRING

**Notes:**

# DISTRIBUTED I/O SALES GUIDE



## AS-interface®, Cable Specifications

- AS-interface Cable that Meets the Requirements of EN50295e for Communication up to 167 Kbaud
- Maximum Cable Length per Segment is 100 Meters

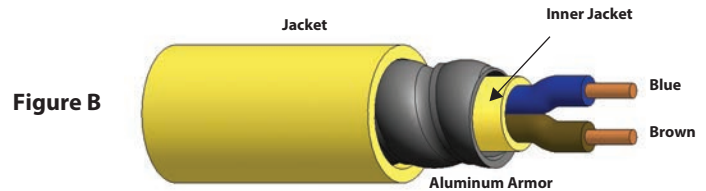





Type	Approvals	Data Pair		Outer Jacket	Bulk Cable Number / Weight/300 M	Figure
		AWG Color Code	DCR (/1000 feet) Insulation	Material Color Nominal O.D.		
<b>254BK</b> AWM 2586 105°C 600 Volts	<b>NEC ITC</b> PLTC Exposed Run Direct Burial <b>CEC</b> [CMG] FT4	2/16 AWG BU/BN	4.1 Ohms PVC/Nylon	PVC Yellow 7.2 mm (.285 in)	RB51029-*M 53 lbs.	A
<b>254B</b> AWM 2517 105°C 300 Volts	<b>NEC ITC</b> PLTC Exposed Run Direct Burial <b>CEC</b> [CMG] FT4	2/16 AWG BU/BN	4.1 Ohms PVC/Nylon	PVC Blue 7.2 mm (.285 in)	RB50962-*M 53 lbs.	A
<b>255A</b> 105°C 300 Volts	<b>NEC ITC</b> PLTC Direct Burial, ACIC	2/16 AWG BU/BN	4.1 Ohms PVC/Nylon	Armor PVC Yellow 15.1 mm (.595 in)	RB50966-*M 105 lbs. <b>armorfast</b> ®	B
<b>2544</b> AWM 2586 105°C 600 Volts	<b>NEC ITC</b> PLTC Exposed Run, Direct Burial, <b>CEC</b> [CMG] FT4	4/16 AWG BN/WH/BU/BK	4.1 Ohms PVC/Nylon	PVC Yellow 8.5 mm (.352 in)	RB51875-*M 94 lbs.	C

\* Indicates length in meters.  
Standard spool lengths are 30, 75, 100, 150, 200, 225, 300 meters. Consult factory for other lengths.

AS-interface® Media

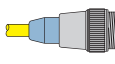
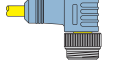
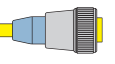
# NETWORK WIRING

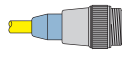
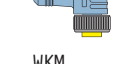
## AS-interface®, Cable and Cordset Selection Matrix

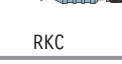
		minifast®				eurofast®	
		Pin (Male)		Socket (Female)		Pin (Male)	
		1  RSM	2  WSM	3  RKM	4  WKM	7  RSC	
 Bare		RSM 25x-*M	WSM 25x-*M	RKM 25x-*M	WKM 25x-*M	RSC 25x-*M	
minifast	Pin (Male)	1  RSM	RSM RSM 25x-*M	RSM WSM 25x-*M	RSM RKM 25x-*M	RSM WKM 25x-*M	RSM RSC 25x-*M
	Pin (Male)	2  WSM		WSM WSM 25x-*M	WSM RKM 25x-*M	WSM WKM 25x-*M	WSM RSC 25x-*M
	Socket (Female)	3  RKM			RKM RKM 25x-*M	RKM WKM 25x-*M	RKM RSC 25x-*M
	Socket (Female)	4  WKM				WKM WKM 25x-*M	WKM RSC 25x-*M
eurofast	Pin (Male)	7  RSC					RSC RSC 25x-*M
	Pin (Male)	8  WSC					
	Socket (Female)	9  RKC					
	Socket (Female)	10  WKC					

See pages H169 - H170 for dimensional drawings.

\* Indicates length in meters.

x Indicates cable type.

Standard cable lengths are 1, 2, 4, 6, 8, 10, 15, and in +5 meter increments from there. Consult factory for other lengths.



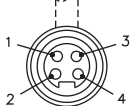
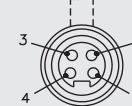
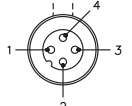
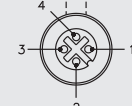



For stainless steel coupling nuts change part number RSM... to RSV, WSM... to WSV. For **eurofast armorfast®** change part number RSC... to RSA.

minifast		Pinouts	eurofast	
Male 	Female 	1. Brown (+ Voltage) 2. N/C 3. Blue (- Voltage) 4. N/C	Male 	Female 

# DISTRIBUTED I/O SALES GUIDE

## AS-interface®, Cable and Cordset Selection Matrix



eurofast®			minifast® Bulkhead		eurofast Bulkhead	
Pin (Male)	Socket (Female)		Pin (Male)	Socket (Female)	Pin (Male)	Socket (Female)
<b>8</b>  WSC	<b>9</b>  RKC	<b>10</b>  WKC	<b>5</b>  RSFP	<b>6</b>  RKFP	<b>11</b>  FSFD	<b>12</b>  FKFD
WSC 25x-*M	RKC 25x-*M	WKC 25x-*M	RSFP 25x-*M	RKFP 25x-*M	FSFD 25x-*M	FKFD 25x-*M
RSM WSC 25x-*M	RSM RKC 25x-*M	RSM WKC 25x-*M	RSM RSFP 25x-*M	RSM RKFP 25x-*M	RSM FSFD 25x-*M	RSM FKFD 25x-*M
WSM WSC 25x-*M	WSM RKC 25x-*M	WSM WKC 25x-*M	WSM RSFP 25x-*M	WSM RKFP 25x-*M	WSM FSFD 25x-*M	WSM FKFD 25x-*M
RKM WSC 25x-*M	RKM RKC 25x-*M	RKM WKC 25x-*M	RKM RSFP 25x-*M	RKM RKFP 25x-*M	RKM FSFD 25x-*M	RKM FKFD 25x-*M
WKM WSC 25x-*M	WKM RKC 25x-*M	WKM WKC 25x-*M	WKM RSFP 25x-*M	WKM RKFP 25x-*M	WKM FSFD 25x-*M	WKM FKFD 25x-*M
RSC WSC 25x-*M	RSC RKC 25x-*M	RSC WKC 25x-*M	RSC RSFP 25x-*M	RSC RKFP 25x-*M	RSC FSFD 25x-*M	RSC FKFD 25x-*M
WSC WSC 25x-*M	WSC RKC 25x-*M	WSC WKC 25x-*M	WSC RSFP 25x-*M	WSC RKFP 25x-*M	WSC FSFD 25x-*M	WSC FKFD 25x-*M
	RKC RKC 25x-*M	RKC WKC 25x-*M	RKC RSFP 25x-*M	RKC RKFP 25x-*M	RKC FSFD 25x-*M	RKC FKFD 25x-*M
		WKC WKC 25x-*M	WKC RSFP 25x-*M	WKC RKFP 25x-*M	WKC FSFD 25x-*M	WKC FKFD 25x-*M

AS-interface® Media

# NETWORK WIRING

## AS-interface®, minifast® Cordset and Receptacle Connector Dimensions

### Specifications

<b>Overmold:</b>	TPU
<b>Coupling Nut:</b>	Nickel Plated CuZn or Stainless Steel
<b>Contact Carrier:</b>	TPU (Polyurethane)
<b>Contacts:</b>	Gold Plated CuZn
<b>Protection:</b>	NEMA 1, 3, 4, 6P and IEC IP 67
<b>Rated Voltage:</b>	300 V
<b>Rated Current:</b>	9 A
<b>Ambient Temperature:</b>	-40° to +105°C (-40° to +221°F)

1

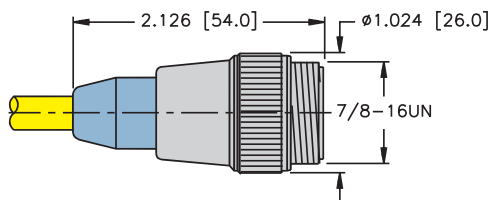

RSM ..

Pages H167

2

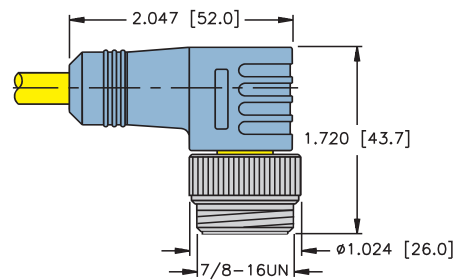

WSM ..

Pages H167

3

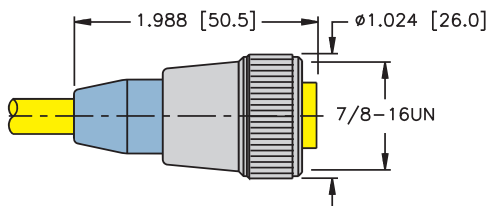

RKM ..

Pages H167

4

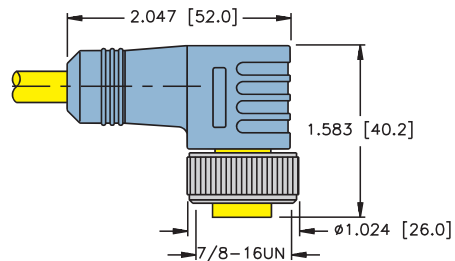

WKM ..

Pages H167

5

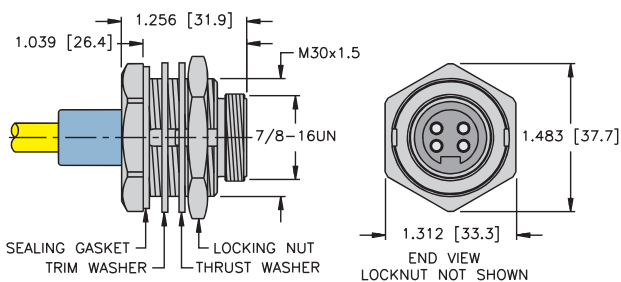

RSFP ..

Pages H168

6

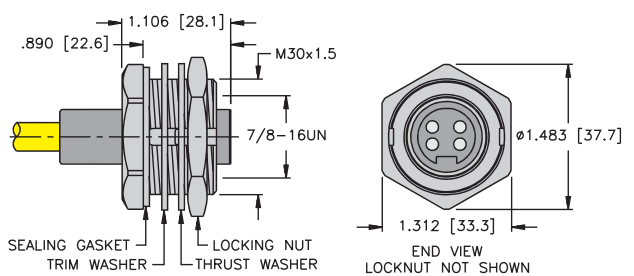

RKFP ..

Pages H168

### Specifications

<b>Overmold:</b>	TPU
<b>Coupling Nut:</b>	Nickel Plated CuZn or Stainless Steel
<b>Contact Carrier:</b>	TPU or POM (Nylon)
<b>Contacts:</b>	Gold Plated CuZn
<b>Protection:</b>	NEMA 1, 3, 4, 6P and IEC IP 68
<b>Rated Voltage:</b>	250 V
<b>Rated Current:</b>	4 A
<b>Ambient Temperature:</b>	-40°C to +105°C (-40° to +221°F)

7

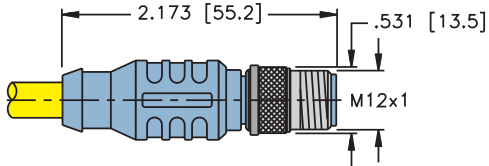

RSC ..

Pages H167

8

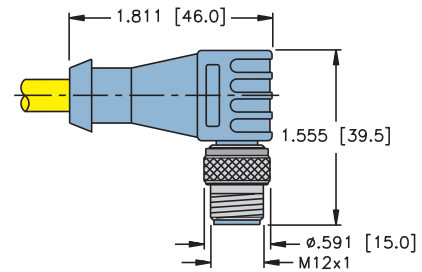

WSC ..

Pages H167

9

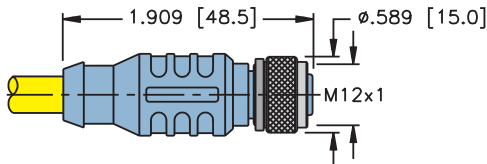

RKC ..

Pages H167

10

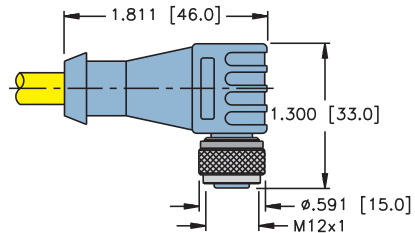

WKC ..

Pages H167

11

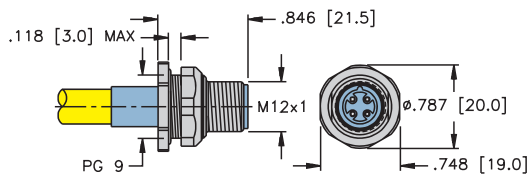

FSFD ..

Pages H168

12

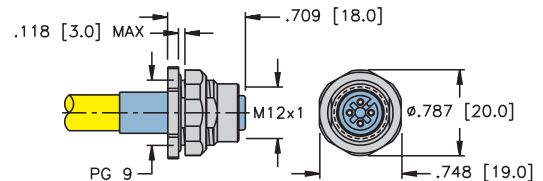

FKFD ..

Pages H168

# NETWORK WIRING

## AS-interface®, Tees

- Creates a Drop or Branch from the Main Bus Line
- Available in *minifast*® or *eurofast*® Bus or Drop Lines



Housing	Part Number	Application	Wiring Diagrams
	<b>RSV-2RKV 25</b>	TPU (Polyurethane), stainless steel, 250 V, 4 A ( <i>eurofast</i> ), 9 A ( <i>minifast</i> ), -40° to +80°C, <i>minifast</i> drop connector	
	<b>RSV FKV RKV 25</b>	TPU (Polyurethane), stainless steel, 250 V, 4 A ( <i>eurofast</i> ), 9 A ( <i>minifast</i> ), -40° to +80°C, <i>eurofast</i> drop connector	
	<b>RSCV 2RKCVCV 25</b>	TPU (Polyurethane), stainless steel, 250 V, 4 A ( <i>eurofast</i> ), -30° to +90°C, <i>eurofast</i> female drop connector	
	<b>RKC 2RSC 25</b>	TPU (Polyurethane), stainless steel, 250 V, 4 A ( <i>eurofast</i> ), -30° to +90°C, <i>eurofast</i> male drop connector, nickel plated brass	
	<b>RSCV WKCV 25</b>	TPU (Polyurethane), stainless steel, 250 V, 4 A ( <i>eurofast</i> ), -40° to +105°C, <i>eurofast</i> male elbow	
	<b>RSC RKC 25</b>	TPU (Polyurethane), stainless steel, 250 V, 4 A ( <i>eurofast</i> ), -40° to +105°C, <i>eurofast</i> male	

<i>minifast</i>		Pinouts	<i>eurofast</i>	
<b>Male</b> 	<b>Female</b> 	1. Brown (+ Voltage) 2. N/C 3. Blue (- Voltage) 4. N/C	<b>Male</b> 	<b>Female</b> 

# DISTRIBUTED I/O SALES GUIDE



## AS-interface®, Gender Changers and Elbow Connectors

- Allows Quick and Easy Change from Male to Female *minifast*® Connectors



Housing	Part Number	Specs	Application	Wiring Diagrams
	RSM RSM 25		<b>minifast</b> Male Gender Changer <ul style="list-style-type: none"> <li>Female cordset to male receptacle</li> </ul>	
	RKM RKM 25	TPU (Polyurethane) 250 V, 9 A -40° to +80°C	<b>minifast</b> Female Gender Changer <ul style="list-style-type: none"> <li>Male cordset to female receptacle</li> </ul>	
	WSM RKM 25		<b>minifast</b> Elbow <ul style="list-style-type: none"> <li>Right angle male to female connector</li> </ul>	

<i>minifast</i>	Pinouts	<i>minifast</i>
<b>Male</b> 	1. Brown (+ Voltage) 2. N/C 3. Blue (- Voltage) 4. N/C	<b>Female</b> 

# NETWORK WIRING

## AS-interface®, eurofast® Flat Cable Adapter

- Allows the Mixing of Standard AS-I Flat Cable with eurofast Round Cable in Same System
- May be Needed when Going from a Dry to a Wet Environment or an Area Where Better Sealing and Rugged Connectors are Required

Housing Style	Part Number	Specs	Pinout
	ASI-PM-1 BW1239	TPU (Polyurethane) 250 V, 4 A -40° to +75°C	<p><b>Female</b></p>
	ASI-PM 41		

	Type	Approvals	Data Pair		Outer Jacket Material Color Nominal O.D.	Bulk Cable Part Number / Weight/300 M
			AWG Color Code	DCR (/1000 feet) Insulation		
	<b>2501</b> 105° 300 Volts	AWM 2103	2/16 AWG BU/BN	4.1 Ohms TPE	TPE Yellow Flat	RB51822-*M 42 lbs.
	<b>2511</b> 105° 300 Volts	AWM 2103	2/16 AWG BU/BN	4.1 Ohms TPE	TPE Black Flat	RB51821-*M 42 lbs.
	<b>253G</b> 75°C 300 Volts	NEC PLTC CEC AWM I/II A/B FT4	2/16 AWG BU/BN	4.1 Ohms PVC	TPE Grey Flat	RB51240-*M 42 lbs.
	<b>253BK</b> 75°C 300 Volts	NEC PLTC CEC AWM I/II A/B FT4	2/16 AWG BU/BN	4.1 Ohms PVC	TPE Black Flat	RB51241-*M 42 lbs.
	<b>253Y</b> 75°C 300 Volts	NEC PLTC CEC AWM I/II A/B FT4	2/16 AWG BU/BN	4.1 Ohms PVC	TPE Yellow Flat	RB51242-*M 42 lbs.

\* Indicates length in meters.

Standard cable lengths are 1, 2, 4, 5, 6, 8, 10, 15, and in +5 meter increments from there. Consult factory for other lengths.

# DISTRIBUTED I/O SALES GUIDE



## AS-interface®, minifast® Male Receptacles

- Provides Quick Connection to Field Devices or Enclosures
- Available for 1/2-14NPT, 1/2-14NPSM, 3/4-14NPT and M20 Threads
- (7/8-16UN) minifast Connection



Housing	Female Part Number	Male Part Number	Application	Pinouts	
<p><b>RKF 25.../14.5</b></p>	RKF 25-*M/14.5	RSF 25-*M/14.5	Nickel plated CuZn or stainless steel 300 V, 9 A, -40° to +105°C, 1/2-14NPT full length threads	<p><b>Female</b></p>	
<p><b>RSF 25.../14.5</b></p>					
<p><b>RKF 25.../14.75</b></p>	RKF 25-*M/14.75	RSF 25-*M/14.75	Nickel plated CuZn or stainless steel 300 V, 9 A, -40° to +105°C, 3/4-14NPT full length threads		
<p><b>RSF 25.../14.75</b></p>					
<p><b>RKF 25.../M20</b></p>	RKF 25-*M/M20	RSF 25-*M/M20	Nickel plated CuZn or stainless steel 300 V, 9 A, -40° to +105°C, M20x1.5 threads		<p><b>Male</b></p>
<p><b>RSF 25.../M20</b></p>					

Standard cable length is 0.5 meters. Consult factory for other lengths.  
 Standard housing material is nickel plated brass. "RKF .."; "RKFV .." indicates 316 stainless steel housing.  
 For locknuts to be included, add "W/LN" to the end of the part number.

AS-interface® Media

# NETWORK WIRING

## AS-interface®, minifast® Male Receptacles

- Provides Quick Connection to Field Devices or Enclosures
- Available for 1/2-14NPT, 1/2-14NPSM, 3/4-14NPT and M20 Threads
- (7/8-16UN) minifast Connection



Housing	Female Part Number	Male Part Number	Application	Pinouts
<p><b>RKF ..</b></p> <p><b>RSF ..</b></p>	RKF 25-*M	RSF 25-*M	Nickel plated CuZn or stainless steel 300 V, 9 A -40° to +105°C, 1/2-14NPSM threads	<p><b>Female</b></p> <p><b>Male</b></p>

Standard cable length is 0.5 meters. Consult factory for other lengths.  
 Standard housing material is nickel plated brass. "RKF .."; "RKFV .." indicates 316 stainless steel housing.  
 For locknuts to be included, add "W/LN" to the end of the part number.

# DISTRIBUTED I/O SALES GUIDE

## AS-interface®, eurofast® Male Receptacles



- Mounted for Quick Connection to Enclosures
- (M12x1) eurofast Connectors



Housing	Female Part Number	Male Part Number	Application	Pinout
<p><b>FK 25...14.5</b></p> <p><b>FS 25...14.5</b></p>	FK 25-*M/14.5	FS 25-*M/14.5	Nickel plated CuZn or stainless steel, 250 V, 4 A, -40° to +105°C, 1/2-14NPT full length threads	<p><b>Female</b></p>
<p><b>FK 25...14.75</b></p> <p><b>FS 25...14.75</b></p>	FK 25-*M/14.75	FS 25-*M/14.75	Nickel plated CuZn or stainless steel, 250 V, 4 A, -40° to +105°C, 3/4-14NPT full length threads	
<p><b>FK 25.../M20</b></p> <p><b>FS 25.../M20</b></p>	FK 25-*M/M20	FS 25-*M/M20	Nickel plated CuZn or stainless steel, 250 V, 4 A, -40° to +105°C, M20x1.5 threads	<p>1. BN 2. N/C 3. BU 4. N/C</p> <p><b>Male</b></p>

Standard cable length is 0.5 meters. Consult factory for other lengths.  
Standard housing material is nickel plated brass. "RKF .."; "RKFV .." indicates 316 stainless steel housing.

# NETWORK WIRING

## AS-interface®, eurofast® Male Receptacles

- Mounted for Quick Connection to Enclosures
- (M12x1) eurofast Connectors

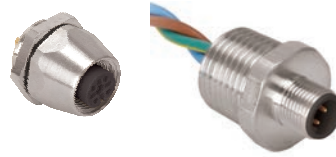

Housing	Female Part Number	Male Part Number	Application	Pinout
<p><b>FK 25...</b></p> <p><b>FS 25...</b></p>	FK 25-*M	FS 25-*M	Nickel plated CuZn or stainless steel, 250 V, 4 A, -40° to +105°C, PG 9 threads	<p><b>Female</b></p> <p><b>Male</b></p>

Standard cable length is 0.5 meters. Consult factory for other lengths.  
 Standard housing material is nickel plated brass. "RKF .."; "RKFV .." indicates 316 stainless steel housing.

# DISTRIBUTED I/O SALES GUIDE



## AS-interface®, minifast® Field Wireable Connectors with Labels

- Allows for Quick Connection when Pre-Molded Cables not Available
- Available for Male and Female Connectors
- Color Coded Wire Connection for AS-interface



Housing Style	Female Part Number	Male Part Number	Features	Pinouts
<p><b>BK 41..</b></p> <p><b>BS 41..</b></p>	BK 4140-0/9/ASI	BS 4140-0/9/ASI	Glass filled nylon, PG 9 cable gland, accepts 6-8 mm cable diameter, screw terminals, 90°C, 250 V, 9 A, mates with standard, 4-pin cordsets and receptacles	<p><b>Male</b></p>
<p><b>BKV 41..</b></p> <p><b>BSV 41..</b></p>				BKV 4140-0/9/ASI

# NETWORK WIRING

## AS-interface®, eurofast® Field Wireable Connectors with Labels

- Allows for Quick Connection when Pre-Molded Cables are not Available
- Available for Male and Female Connectors
- Color Coded Wire Connection for AS-interface



Housing Style	Female Part Number	Male Part Number	Features	Pinouts
<p><b>B 81..</b></p> <p><b>BS 81..</b></p>	<p><b>B 8141-0/PG9/ASI</b></p>	<p><b>BS 8141-0/PG9/ASI</b></p>	<p>PBT, black, PG 9 cable gland, accepts 6-8 mm cable diameter, screw terminals, 85°C, 250 V, 4 A, mates with standard, 4-pin cordsets and receptacles</p>	<p><b>Female</b></p>
<p><b>B 82..</b></p> <p><b>BS 82..</b></p>				

# DISTRIBUTED I/O SALES GUIDE



## AS-interface®, Gender Changer

- Allows Quick and Easy Change from Male to Female and (7/8-16UN) *minifast*® to (M12x1) *eurofast*® Connectors



Housing Style	Part Number	Features	Wiring Diagram															
	RSM 25-FK 4.5	Nickel plated CuZn or stainless steel, 250 V, 4 A, -40°C to +75°C, female <i>eurofast</i> , male <i>minifast</i> , 4-pin	<table border="0"> <tr> <td>MALE</td> <td></td> <td>FEMALE</td> </tr> <tr> <td>1</td> <td>←</td> <td>1</td> </tr> <tr> <td>2</td> <td>←</td> <td>2</td> </tr> <tr> <td>3</td> <td>←</td> <td>3</td> </tr> <tr> <td>4</td> <td>←</td> <td>4</td> </tr> </table> <p>P1 ← J1</p>	MALE		FEMALE	1	←	1	2	←	2	3	←	3	4	←	4
MALE		FEMALE																
1	←	1																
2	←	2																
3	←	3																
4	←	4																

### Pinouts

<i>minifast</i>	<i>eurofast</i>
<p><b>Male</b></p>	<p><b>Female</b></p>

# NETWORK WIRING

## AS-interface®, Conduit Adapters

- Converts Standard Conduits to Quick Disconnect
- Fiberglass Reinforced Nylon Housings
- Nickel Plated Brass Connectors Available
- 3/4" Form 8 or Mark 9
- 1" Form 7 Available Upon Request
- Gasket and Mounting Screws Provided
- IP67



Housing Style	1 Port Part Number	2 Port Part Number	Specifications	Pinouts
	BCA-25-E123	BCA-25-E223	IP 67 Rating, conduit cover for 3/4" Form 8 or Mark 9, Stainless Steel M12 x 1 Connectors	
	BCA-25SC-E123	BCA-25SC-E223	IP 67 Rating, conduit cover for 3/4" Form 8 or Mark 9, Stainless Steel M12 x 1 Connectors, Short Circuit Protection	
	BCA-25-M123	BCA-25-M223	IP 67 Rating, conduit cover for 3/4" Form 8 or Mark 9, Stainless Steel 7/8"-16UN Connectors	

## AS-interface®, Wall Plate Adapters

- Attaches to Standard Single Gang Electrical Box
- Stainless Steel with Stainless Steel Connectors
- Gasket and Mounting Screws Provided
- IP67



Housing Style	Part Number	Specifications	Pinouts
	BPA-25-M113	IP 67 Rating, Stainless Steel 7/8"-16UN Connector	

## AS-interface®, On-Machine Passive Junction Boxes

- Multiple Port Configurations Available
- Cast aluminum Housing\*
- 7/8" x 1 Bus In/Bus Out Connectors\*
- Nickel Plated Brass Connectors Available
- IP67

\*(Unless otherwise specified)



Housing Style	M12x1 Connectors	7/8-16UN Connectors	Specifications	Pinouts
	JBBS-25-E613	JBBS-25-M613	Stainless Steel Connectors, CSA General Purpose Approval, -40°C to +70°C (-40°F to +158°F)	
	JBBS-25-E813	JBBS-25-M813	Stainless Steel Connectors, CSA General Purpose Approval, -40°C to +70°C (-40°F to +158°F)	
	JBBS-25SC-E613/S0	JBBS-25SC-M613/S0	Stainless Steel Connectors, CE approval. Short Circuit Protection, -30°C to +80°C (-22°F to +176°F)	
	JBBS-25SC-E813/S0	JBBS-25SC-M813/S0	Stainless Steel Connectors, CE approval. Short Circuit Protection, -30°C to +80°C (-22°F to +176°F)	
	JBBS-25-E413	JBBS-25-M413	Stainless Steel Connectors, CSA General Purpose Approval, -40°C to +70°C (-40°F to +158°F)	

# NETWORK WIRING

## AS-interface®, In-Cabinet Passive Junction Boxes

- Multiple Port Configurations Available
- Extruded Aluminum Housing
- Removable Screw Terminals
- -40°C to +85°C (-40°F to +185°F)
- IP20



Housing Style	Part Number	Specifications	Pinouts
	JRBS-25-12R	Bus-in/Bus-out plus 12 drops	No Image Supplied
	JRBS-25-10R	Bus-in/Bus-out plus 10 drops	No Image Supplied
	JRBS-25-8R	Bus-in/Bus-out plus 8 drops	No Image Supplied

# DISTRIBUTED I/O SALES GUIDE



## AS-interface®, In-Cabinet Passive Junction Boxes

- Multiple Port Configurations Available
- Extruded Aluminum Housing
- Removable Screw Terminals
- -40°C to +85°C (-40°F to +185°F)
- IP20



Housing Style	Part Number	Specifications	Pinouts
	<b>JRBS-25-6R</b>	Bus-in/Bus-out plus 6 drops	No Image Supplied
	<b>JRBS-25-4R</b>	Bus-in/Bus-out plus 4 drops	No Image Supplied

AS-interface® Media

# Network Overviews

The Network Overview Guide endeavors to provide a high level overview of the common network protocols supported by TURCK Distributed I/O. Each network overview gives a summary of the key specifications for that protocol. The overviews provide standard network topologies, maximum ratings and physical media options to educate on basic design and product selection.



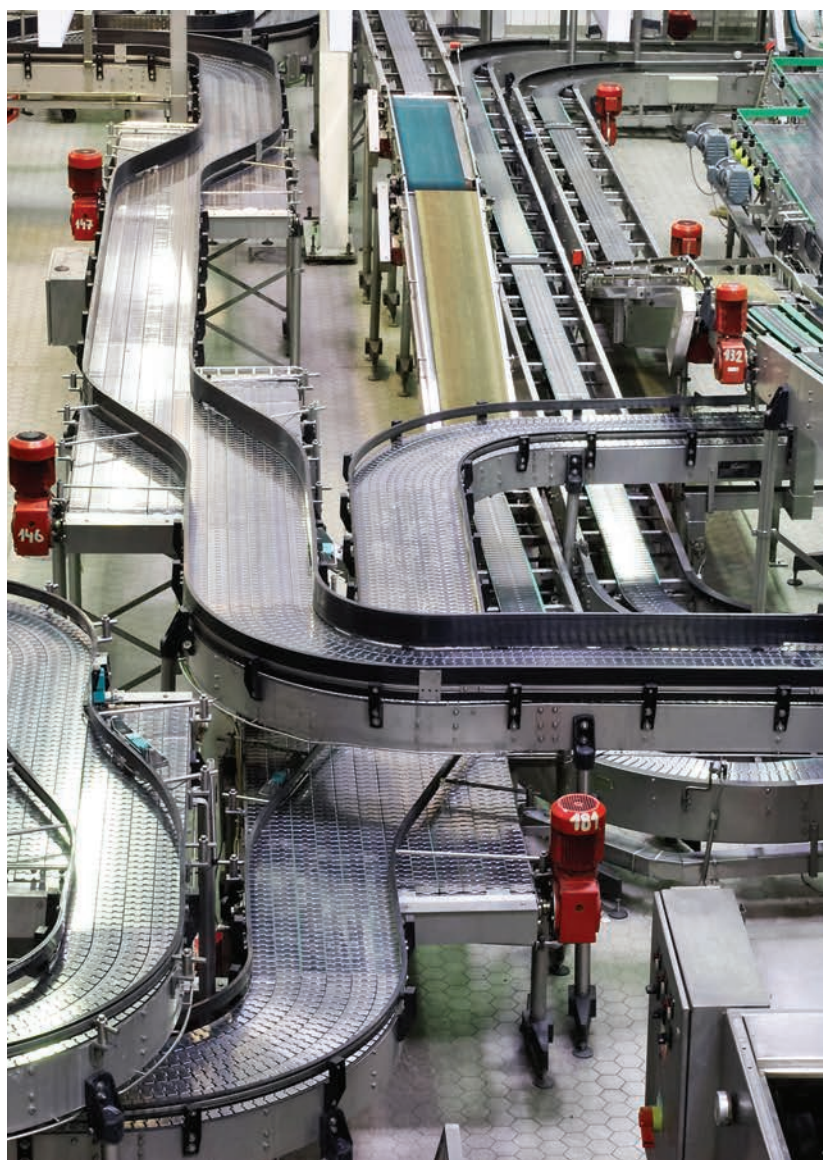

<b>Network</b>	<b>PAGE</b>
<b>Ethernet</b>	<b>J3</b>
<b>PROFIBUS®</b>	<b>J9</b>
<b>FOUNDATION™ fieldbus</b>	<b>J13</b>
<b>CANopen</b>	<b>J19</b>
<b>AS-interface®</b>	<b>J23</b>
<b>DeviceNet™</b>	<b>J29</b>

# Ethernet

## At-A-Glance

### What is it?

Industrial Ethernet is the result of applying traditional Ethernet standards for data communication to industrial applications

### What are its basic components?

I/O slaves (Servers), masters (Clients), communication cable and power supply and cable

### Where is it used?

Industrial automation, mobile equipment, transportation, medical, military and PLC to PLC communication

### Who is responsible for it?

Ethernet physical layer is standardized in IEEE 802.3. Application layers like EtherNet/IP, PROFINET and Modbus TCP are open standards with independent governing bodies.

## Overview

Ethernet is the most commonly used computer networking technology for local area networks (LANs) and is standardized in IEEE 802.3. As Ethernet continues to find its way into other applications, it is rapidly becoming the network of choice for higher-level industrial control applications. Industrial Ethernet is the result of applying traditional Ethernet standards for data communication to industrial applications. Industrial Ethernet is primarily used to connect PLCs, computers, HMI displays and other high-level components. The term "Ethernet" refers to the lower-level communication structure. Various versions, or implementations, of Ethernet are available, such as Ethernet/IP™, PROFINET® and Modbus®-TCP. It is important to note that while all of these different specifications use the same physical communication method and can operate on the same cable simultaneously, they cannot necessarily communicate with each other. For example, Modbus-TCP devices cannot communicate with Ethernet/IP devices because the messages and communication protocol have been defined differently for these systems, even though the physical electrical structure is the same.

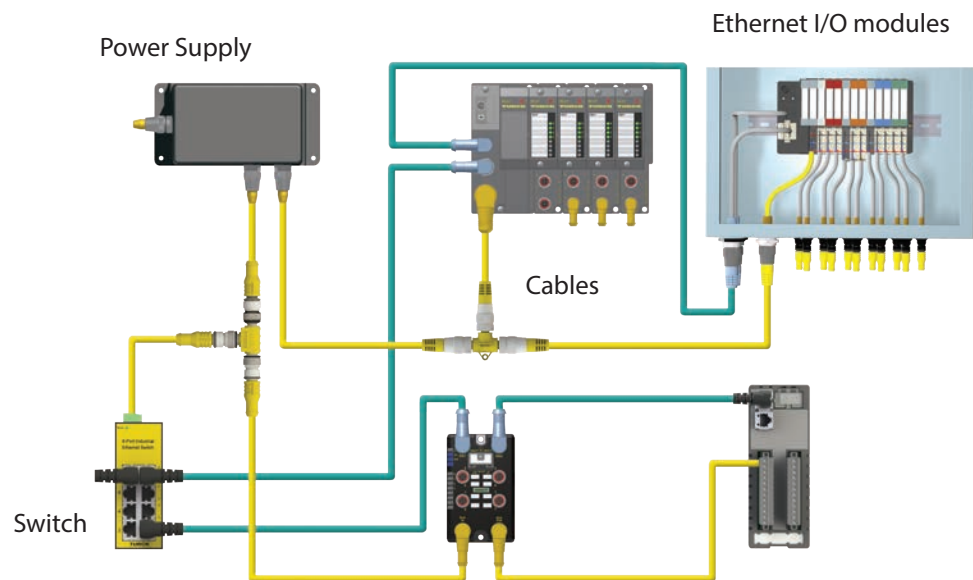

## Basic Parts List

A typical system consists of the following parts:

- Power Supply
- Ethernet I/O modules
- Cables
- Switch

## System Configuration

Ethernet I/O modules act as servers on a network. A client device is needed to retrieve data from and post data to the server. This is analogous to an office network, where the client PC on a user's desk may actively connect with multiple servers to access information in different areas of the enterprise. TURCK industrial Ethernet stations are designed to be fully compatible with established Ethernet standards for industrial use.

There are a variety of topologies that can be used for Ethernet configuration such as star topology, line topology and ring topology:

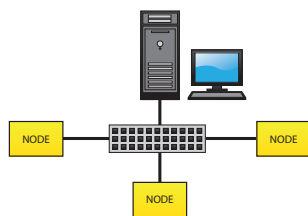

STAR TOPOLOGY

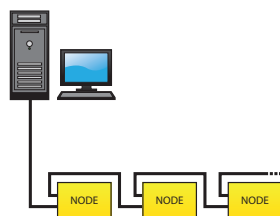

LINE TOPOLOGY

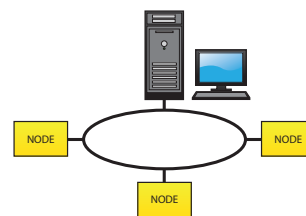

DEVICE-LEVEL RING (DLR) TOPOLOGY

## Addressing

Industrial Ethernet stations use the IP addressing scheme. An address defined by this scheme consists of four byte values usually displayed in decimal form, for example, 192.168.1.254. Various classifications of networks require different portions of this address to be constant for all devices on the network (referred to as a “subnet”). This means that the number of stations allowed on a particular network varies depending on what class of subnet is being used. If the first three bytes of the IP address are constant (which is common), then the remaining byte may be addressed between 2 and 254, resulting in 253 possible addresses.

## Maximum Ratings

Ethernet allows different maximum cable lengths depending on the type of cable being used. Generally, an Ethernet segment may be as long as 100 m, where 90 m must be solid core cable and the remaining 10 m can be stranded patch cords.

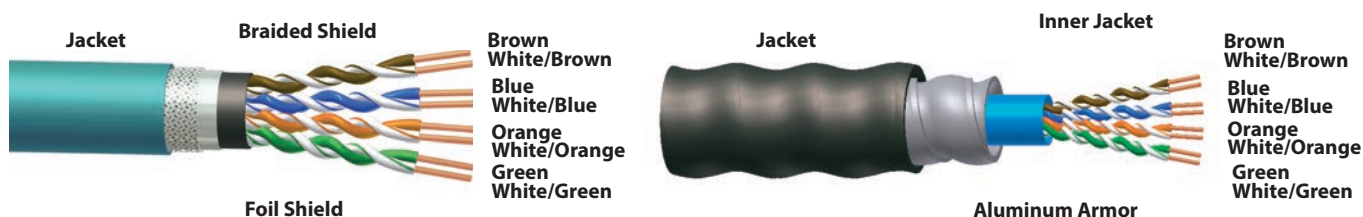

## Cordsets

TURCK offers a complete line of molded Ethernet cordsets to facilitate network installation, resulting in faster start-up and fewer wiring errors. Cables are available with stranded or solid-core conductors, and with or without shielding. Most TURCK Ethernet equipment uses the 4 or 8-pin (M12) eurofast® connector specifications. These connectors provide a tough, rugged seal and are IP67-rated. In some cases, (mainly in the control cabinet) a traditional RJ45 Ethernet connector needs to be used. TURCK provides RJ45 cordsets, as well as a variety of devices made to convert between RJ45 and eurofast connectors. TURCK cordsets for the Ethernet system are available in standard lengths, in addition to custom lengths through the company’s sales representatives.

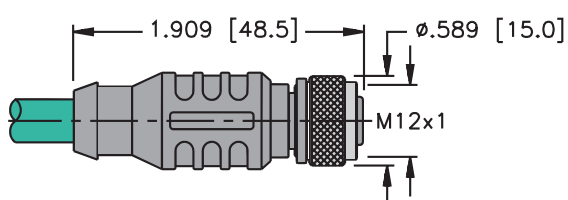

eurofast connector

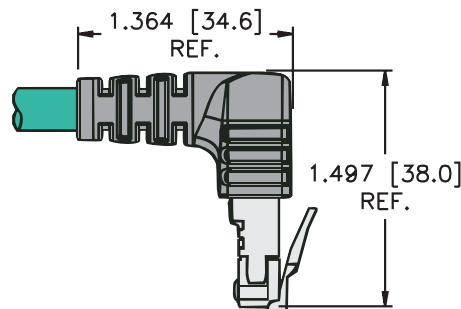

RJ45 connector

## Diagnostics

Industrial Ethernet stations support diagnostics information, which is based on their complexity and functionality. The common ground for all devices is that they provide visual diagnostic information using either a pair of status LEDs called MOD and NET LEDs or a single combined MOD/NET LED. Industrial Ethernet stations may also include an embedded webserver that can be accessed by a web browser, such as Internet Explorer. This embedded webserver can be accessed to provide diagnostic information anywhere in the world. TURCK discrete IO modules provide diagnostic data as a part of input data map. Standard stations support group diagnostics, where a single alarm bit is set if any IO is faulted. Deluxe station support individual IO diagnostic data, including open wire and short wire alarm bits.

## EtherNet/IP

### Overview

EtherNet/IP is a communication protocol supported by the ODVA and is designed for use in industrial automation and process control applications. It takes the Common Industrial Protocol (CIP) and implements it onto the foundation of Ethernet. CIP envelops a wide-ranging suite of messages and services for a variety of applications, including safety, control, configuration and information. Ethernet/IP provides users with tools to deploy standard Ethernet technology for industrial applications.

### Supported Features:

- ACD – Address Conflict Detection – This supported feature will detect if another device on the network has the same IP address. If a conflict is detected, the device will go into a recoverable fault state and set the status LEDs to indicate a fault
- DLR – Device Level Ring – Device Level Ring (DLR) is a fault tolerant network allowing continuous system operation when a single fault occurs in the end node, its network interface or cable system. The adoption of an integrated Ethernet switch in the multiprotocol products allows support for DLR across all product families
- Quick Connect

### Addressing Options:

- Rotary Mode – IP address is preconfigured
- Programmable
- Webserver
- Boot-P
- DHCP

### Configuration Options:

- Generic Ethernet Device – Standard setup of Ethernet products in Logix 5000 that are not Rockwell made products
- EDS support – Contrologix v20 and Omron
- CIP Bridge – Allen Bradley PLCs only – This feature allows total setup and configuration of supported multiprotocol products within the Rockwell software (Logix 5000)
- IO Assistant – This free software is a FDT/DTM based technology for engineering, configuring, commissioning and diagnosing multiprotocol products

# PROFINET

## Overview

PROFINET is a communication protocol that was developed by Siemens and the PROFIBUS User Organization (PNO) based on the open Ethernet standard. PROFINET features a modular design structure allowing users to select the cascading functions including standard TCP/IP for applications not requiring real time performance, Real Time (RT) for applications requiring the transfer of critical information and Isochronous Real Time (IRT) for applications using functionality like motion control.

## Supported Features:

- Fast start-up
- GSDML file support
- Topology detection support
- Automatic address assignment – LLDP
- GSDML function configuration

## Addressing Options:

- Rotary mode
- PROFINET name assignment
- Programmable
- DNS-PGM – (x600)
- Webservice

## Configuration Options:

- The PROFINET cordset line offers both M12 Ethernet D-coded and RJ45 connector options, allowing users the option to mix-and-match any connector combination to meet unique application needs

# MODBUS TCP/IP

## Overview

Modbus TCP/IP is the Modbus RTU protocol with a TCP interface running on Ethernet. Modbus was originally designed by Modicon (Schneider Electric) and is now managed by the Modbus-IDA User Organization. TCP/IP refers to Transmission Control Protocol and Internet Protocol, which provides the transmission channel for Modbus TCP/IP messaging. Modbus TCP/IP is used often in the industrial environment due to its ease of deployment and maintenance, and because it was developed specifically for industrial applications.

Modbus TCP/IP can be used with star, tree or line network topology and can be implemented with Ethernet technology that has been adapted for use in the industrial environment.

## Supported Features:

- Bit register and function codes
- 6 parallel Modbus connections
- PACTWARE FDT/DTM configuration and mapping
- Embedded webservice for diagnostics and configuration

## Addressing Options:

- Rotary mode – IP address is preconfigured
- Programmable
- Webserver
- Boot-P
- DHCP

## Configuration Options:

- Controllers can be setup to communicate on standard Modbus networks using either of two transmission modes: ASCII or RTU
- Users select the desired mode, along with the serial port communication parameters (baud rate, parity mode, etc.), during configuration of each controller

## TURCK Multiprotocol

### Overview

TURCK provides a complete line of industrial Ethernet products, including on-machine, in-cabinet, block, and modular I/O. The most recent innovation is the Multiprotocol Industrial Ethernet concept. TURCK's innovative approach to industrial Ethernet I/O makes moving from another protocol, or simply implementing a fieldbus for the first time, plug-in simple. TURCK's Multiprotocol products are self-configuring and offer a seamless transition to Ethernet, whatever Ethernet that may be.

### 1 Device = 3 protocols

- Ethernet/IP, PROFINET and Modbus TCP/IP
- Gateway (slave) recognizes the master upon power-up and self-configures for master protocol
- Supports ODVA quick-connect and Device Level Ring (DLR)
- PROFINET options include: PROFINET RT, and PROFINET Fast Start-up (FSU)
- PROFINET IRT available in standard product configuration
- Embedded web server for device configuration and diagnostics

**Notes:**

## At-A-Glance

### **What is it?**

PROFIBUS® is an industrial network protocol that connects field I/O devices in order to eliminate hard wiring.

### **What are its basic components?**

Master, slaves, communication cable, power supply and power cable (PROFIBUS-DP)

### **Where is it used?**

Machine control applications, process and hazardous area situations

### **Who is responsible for it?**

PROFIBUS is maintained by the international governing body: PI (PROFIBUS & PROFINET INTERNATIONAL)

## Overview

PROFIBUS® is an industrial network protocol that connects field I/O devices in order to eliminate hard wiring. The network connection increases device-level diagnostic capabilities, while also providing high-speed communication between devices.

## PROFIBUS-DP

PROFIBUS-DP is the version of PROFIBUS that is generally used for factory automation and machine control solutions. It is based on the RS-485 serial data transfer standard. In most cases, the termination and physical media rules for PROFIBUS-DP are the same as those required for RS-485 communication. A PROFIBUS-DP network supports up to 126 nodes and virtually an unlimited variety of I/O. The bus uses a trunkline/dropline topology. Power and communication are provided via separate cables, allowing easy segmentation of the power structure to avoid overloading.

PROFIBUS-DP is capable of running at data rates as high as 12 Mbaud. When used at high data rates, the cable drop length from the trunk to a node is severely limited. For example, when used at 12 Mbaud, nodes must be directly connected to the trunk, with no drop length allowed.

Although PROFIBUS-DP is well suited to machine control applications, it is also useful for process and hazardous area situations (in fact the name PROFIBUS is an abbreviation of Process Field BUS). TURCK's excom system allows connection from a PROFIBUS-DP network directly to I/O devices in classified areas, resulting in a huge potential savings on barriers and wiring.

## PROFIBUS-PA

PROFIBUS-PA is another version of PROFIBUS, designed for hazardous area usage though it may also be used in non-hazardous areas due to a variety of reasons such as topology and device parameterizations. It operates as an extension from the PROFIBUS-DP system. Using the same media specification as FOUNDATION™ fieldbus (IEC 61158-2), it allows network communication directly in hazardous areas. All devices on a PROFIBUS-PA system are controlled by the PROFIBUS-DP master. The conversion from DP to PA is accomplished by a linking or gateway device, which converts from the high speed RS-485 DP communication to the lower speed (31.25 kbps) IEC 61158-2 communication required for PROFIBUS-PA. The logical communication structure is identical between the systems; only the physical media is different.

*A typical PROFIBUS-PA network, connected to a higher-level PROFIBUS-DP system*

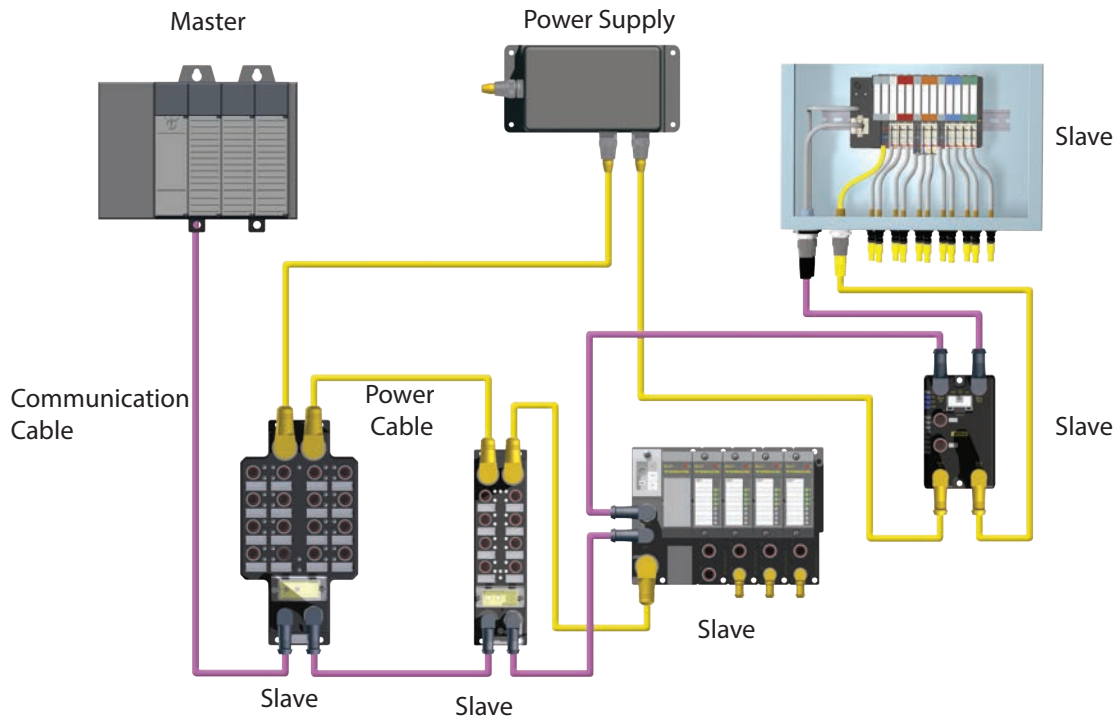

## PROFIBUS® Structure

A typical PROFIBUS system consists of the following parts:

- Master
- Slaves
- Communication cable
- Power supply
- Power cable (PROFIBUS-DP)

PROFIBUS stations require a network master (also called a scanner) to interface the stations to the host controller. TURCK PROFIBUS-DP stations are designed to be fully compatible with PROFIBUS-DP equipment from other manufacturers.

## Communication Rate/Cycle Time

PROFIBUS-DP specifications define multiple transmission speeds ranging from 9.6 kbaud to 12 Mbaud. All nodes on a network must communicate at the same rate. The complete cycle time of a PROFIBUS-DP system is affected by several factors:

- Number of nodes being scanned
- Amount of data produced and consumed by the nodes
- Network communication rate
- Cycle time of the control program
- Number of masters present

All of these factors must be considered when calculating the cycle time of a particular network.

## Maximum Ratings

The PROFIBUS-DP bus uses a trunkline/dropline topology. The trunk is the main communication cable and requires the appropriate RS-485 active termination at both ends of the network. Active termination requires a bias voltage, typically supplied by the network nodes, to function. Turck offers these terminating resistors as a plug-in eurofast(R) unit or built into their D9 connectors. If terminating at the end of the cable is desired, Turck offers a special Terminating resistor in an IP67 form factor that can be supplied externally with this bias voltage.. The length of the trunk depends on the communication rate. Drops or branches off the trunk are allowed, but are greatly limited as the communication rate increases. The table shows the maximum ratings for a PROFIBUS-DP trunk at different communication rates.

COMMUNICATIONS RATE	MAX. SEGMENT LENGTH
9.6 kbps	1200 m
19.2 kbps	1200 m
93.75 kbps	1200 m
187.5 kbps	1000 m
500 kbps	400 m
1.5 Mbps	200 m
12 Mbps	100 m

*PROFIBUS-PA has the same physical limitations as FOUNDATION fieldbus, identified in this table*

CABLE	NUMBER OF DEVICES	MAXIMUM SPUR LENGTH
Trunk	25-32	0 m (0 ft.)
	19-24	30 m (98 ft.)
	15-18	60 m (197 ft.)
1900 meters	15-18	60 m (197 ft.)
	13-14	90 m (295 ft.)
	2-12	120 m (394 ft.)

## Diagnostics

TURCK network stations provide increased diagnostics over using traditional hard-wired I/O systems. TURCK stations also serve as a buffer between I/O devices and the PROFIBUS-DP network by detecting short circuits without disrupting communication. The PROFIBUS-DP system includes a provision for special diagnostic data messages. These messages are triggered when a fault occurs at the station (for example a short circuit on a sensor). When the master asks the station for data, the station responds and includes a flag to indicate that diagnostic data is present. The master then asks for the diagnostic data, which is mapped to a special location in the controller's memory.

## Addressing

The valid range of PROFIBUS node addresses is 0 to 125. TURCK station's addresses are usually set via rotary dials or switches on the node. Changes to the address settings take effect when the station power is cycled or when the station receives a software reset. Care must be taken to prevent the same address from being assigned to more than one node in a system. Bihl+Wiedemann PROFIBUS-DP to AS-i gateways addresses are set in software using the on-unit display.

## Cordsets

TURCK offers a complete line of molded PROFIBUS-DP and PROFIBUS-PA cordsets to facilitate network installation, resulting in a faster start-up and fewer wiring errors. The bus and drop cables are specially designed foil-shielded, high-flex cables with very low inductance and capacitance to minimize propagation delay time. PROFIBUS-DP cables consist of a shielded and twisted data pair with a bare drain wire. PROFIBUS-PA cables feature a shielded, twisted pair for data and bus power and a drain wire.

In most cases, connections of the bus cable to the stations are made using 5-pin reverse-key *eurofast* (M12) connectors for PROFIBUS-DP. A variety of stations are also available that support D9 type connections. Power for most stations is provided through one or two 5-pin *minifast*® (7/8-16UN) connectors.

PROFIBUS-PA connections are typically made with minifast style connectors, though eurofast connections are available as well.

TURCK cordsets for the PROFIBUS system are available in standard lengths. Please contact your local sales representative to order custom lengths.

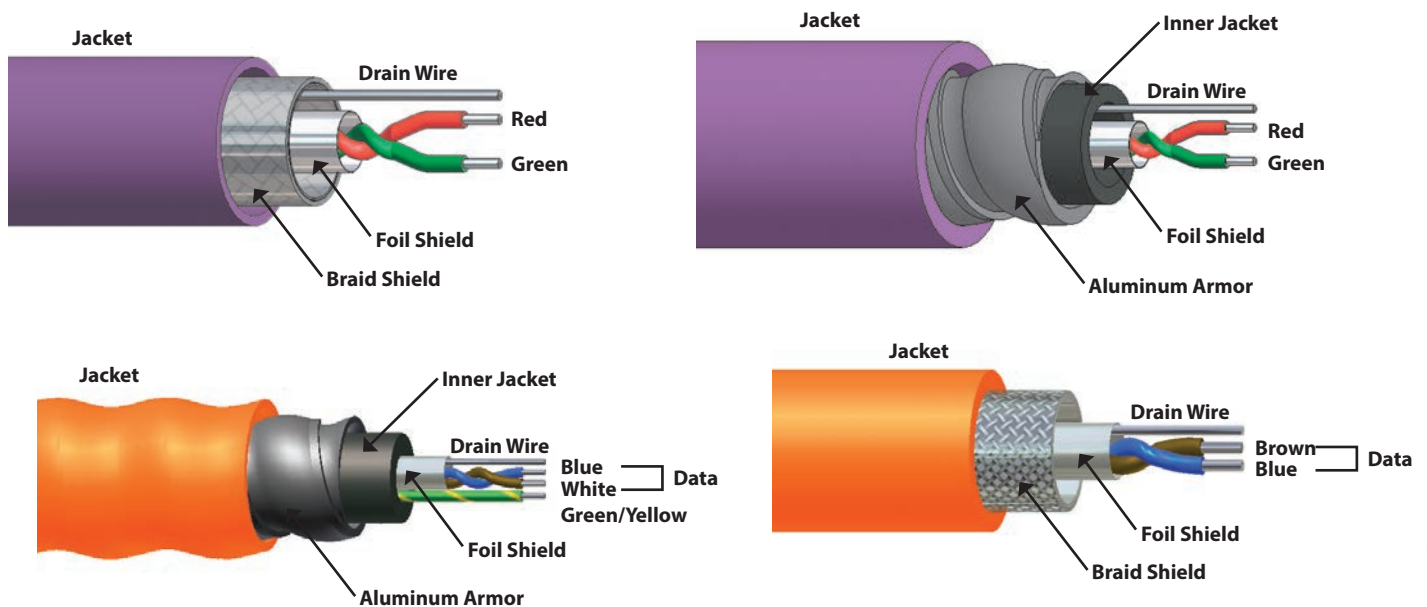

## GSD Files

GSD files contain detailed information about a PROFIBUS-DP device, including I/O data size and the devices configurable parameters. The information in a GSD file, when used with a PROFIBUS-DP configuration tool, guides a user through the steps necessary to configure a device.

# FOUNDATION™ Fieldbus

## At-A-Glance

### What is it?

FOUNDATION fieldbus is an all-digital, serial, two-way communications system for use in applications using basic and advanced regulatory control

### What are its basic components?

H1 fieldbus interface card, fieldbus power supply and signal conditioner, bulk power (Vdc) to fieldbus power supply, terminator and fieldbus devices

### Where is it used?

Plant automation, factory automation, basic and advanced regulatory control, discrete control, process industries, power plants

### Who is responsible for it?

FOUNDATION fieldbus is an open architecture, developed and administered by the Fieldbus Foundation

## Overview

FOUNDATION™ Fieldbus is an all-digital, serial, two-way communications system for use in applications using basic and advanced regulatory control. TURCK's diagnostic power conditioner (DPC) system stores and monitors information concerning the components of the control system and field devices. Information on assets that make up the communication infrastructure (physical layer components) have been simply stored in an asset management system. With the DPC system, the physical layer components are continuously monitored providing virtually instantaneous information regarding the quality and the status of the communication link. This aspect of the system is the key to achieving the main objective of asset management to minimize maintenance and lower system operating costs.

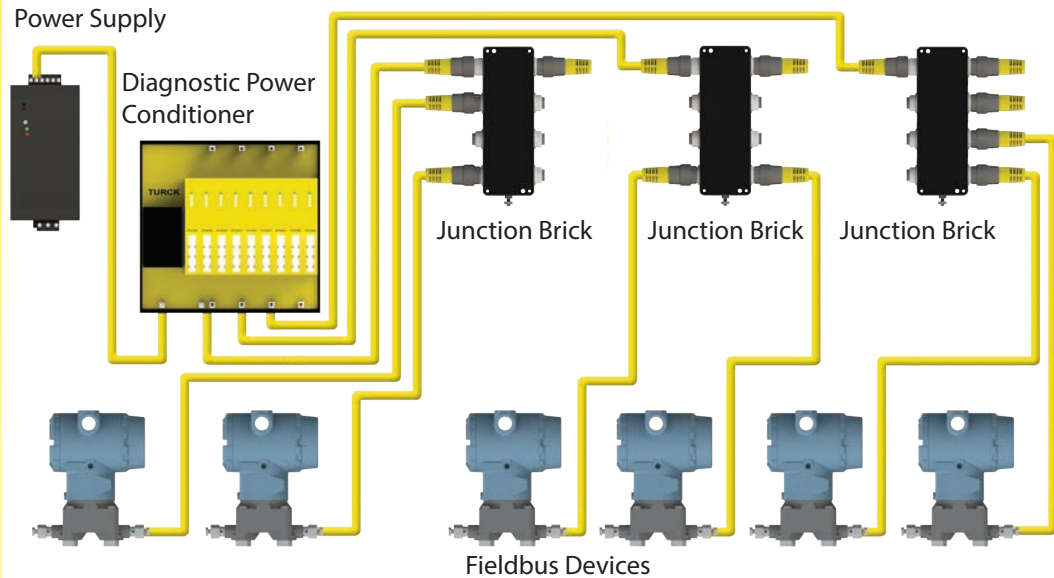

## Basic Parts List

A typical system consists of the following parts:

- Power supply
- Diagnostic power conditioner
- Junction bricks
- Fieldbus devices

## System Configuration

TURCK has drastically improved on existing physical layer components for use in FOUNDATION fieldbus applications. The introduction of the DPC system allows the continuous monitoring of every physical layer component, thus treating the entire physical layer as an asset and providing the means for it to be managed as such.

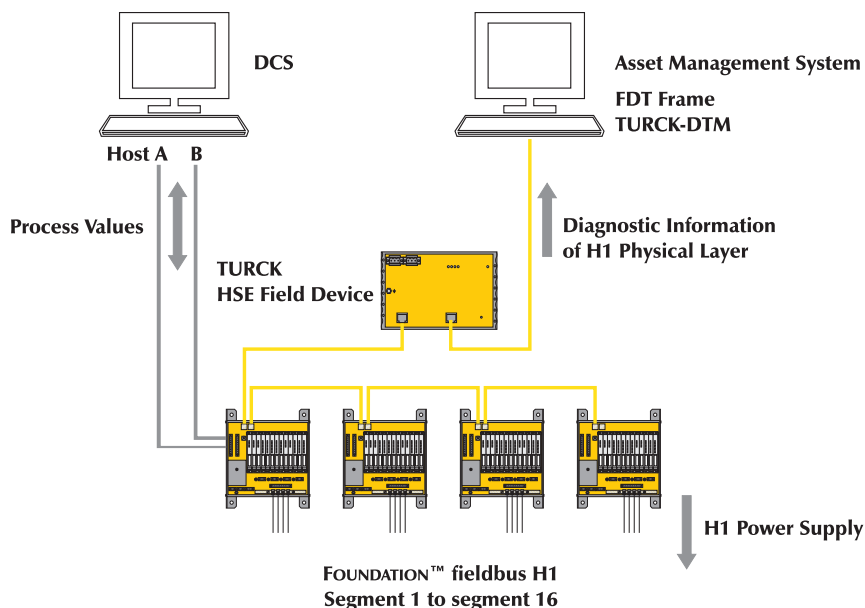

The DPC System detects errors that may develop over an extended period of time or through typical failure modes. These changes can occur due to many factors, such as environmental changes, deterioration of components over time and any other factors that may affect the physical components of a fieldbus segment. Some of these factors may appear as changes in jitter, hum, noise levels etc. Alarm strategies may be employed that will warn of typical asset errors, potential errors or failures. Preventive measures can be implemented well in advance of a potential system failure. Most common failures can be completely avoided when a preventive maintenance schedule is implemented.

The DPC system also supports the set-up of fieldbus assets by using expedient localization of error sources, as well as documentation indicating a “good condition” of the segment structure.

The DPC system provides an option for redundant segment supplies. The system, fully loaded, can accommodate up to 16 fully redundant FOUNDATION fieldbus segments each with an output of 800 mA and 30 VDC. Diagnostic data is available via a DTM, standard FOUNDATION fieldbus function block libraries or an embedded web server in the HSE field device.

# FOUNDATION™ Fieldbus

## Conventional Control System

In a traditional control system, I/O devices in the field are individually wired to a central controller, which is responsible for all control function processing in the system. This type of system typically consumes a lot of physical space (due to the amount of wire and the number of I/O cards in the PLC or DCS) and requires a lot of design and labor to install. Additionally, finding errors in this kind of system can be very time consuming because of the number of possible error points (each physical wire termination).

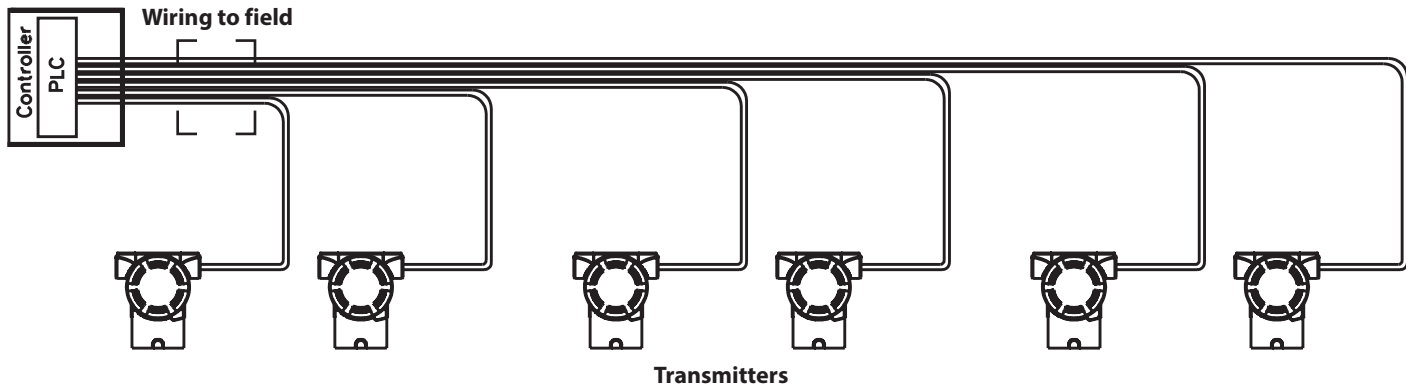

## FOUNDATION™ Fieldbus System

In the fieldbus system, the I/O devices are wired to a trunk line (segment) using tee connectors or multi-drop boxes. Rather than separate pairs of wires carrying data to and from each I/O device, the devices use a common pair of wires for communication, with each having a turn to "talk" on the network. Instead of performing all the control functions in the host, the FOUNDATION fieldbus system allows for control blocks to be executed in the field devices themselves, creating an efficient, high integrity system. One device on the network is responsible for scheduling communication between the various devices on the system. This is called the Link Active Scheduler (LAS). It can be the host interface or a device in the field. In most FOUNDATION fieldbus systems at least one backup LAS is defined as well. This allows communication and control to continue in case the original LAS device fails. Most FOUNDATION fieldbus devices are powered completely from the network supply. In some cases a device may draw enough current to make it impractical to power it from the network. In these cases the device is typically powered from a separate (auxiliary) supply.

Another key benefit of using FOUNDATION fieldbus is the ease of adding I/O devices to the system in the future. Because it is a serial bus where all devices use the same wires for communication, a device can be added by simply splicing it onto the network. This eliminates the need to pull a new wire pair all the way back to the controller.

FOUNDATION fieldbus devices also typically include a multitude of parameters and diagnostic information, all accessible over the network. Advanced diagnostics and maintenance scheduling are made much easier with this feature.

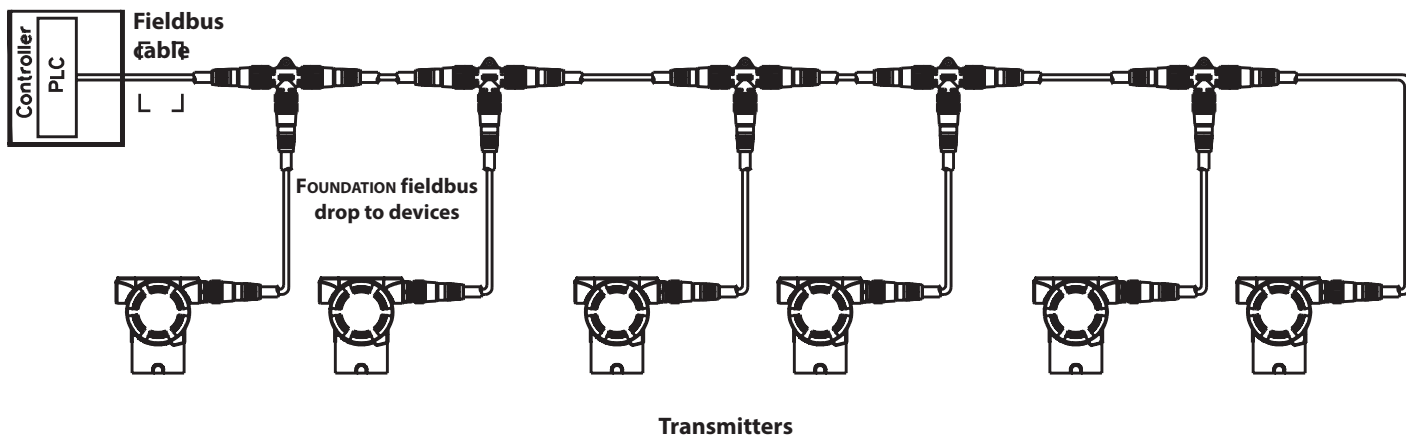

## Communication Signal

The FOUNDATION fieldbus H1 communication signal is a square waveform superimposed on a DC carrier. The frequency of the signal is 31.25 KHz. Although it is not a requirement, most devices derive their supply power from the fieldbus communications cable. The fieldbus specification states that devices must not be polarity sensitive. However, it is good electrical practice to have all devices wired with the same polarities. The voltage range allowed for proper operation is 9 to 32 VDC. A typical fieldbus device will consume 20 mA of current.

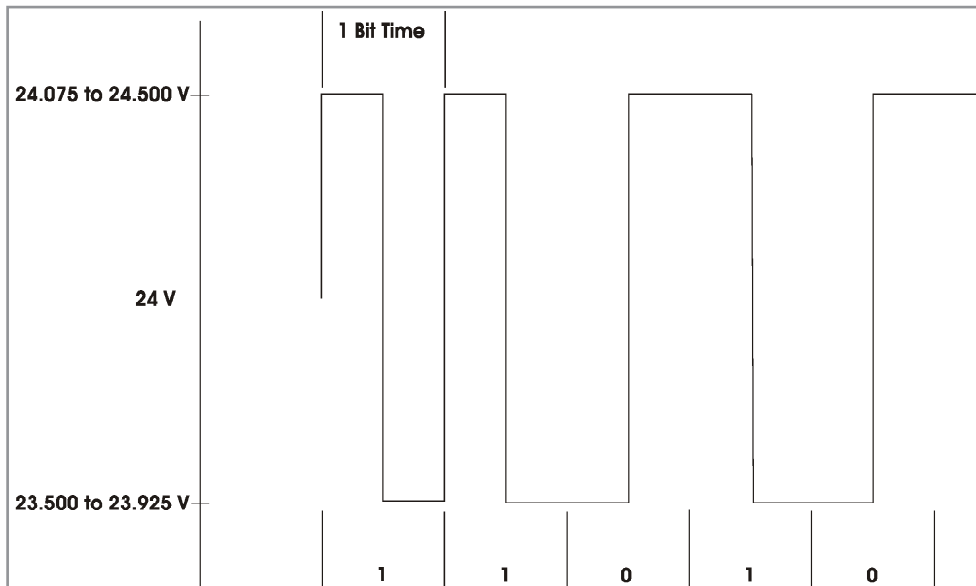

**Idealized FOUNDATION fieldbus communication signal**

## Fieldbus Cable Specifications

The specifications for fieldbus H1 physical media are defined by IEC 61158-2 and the ISA-S50.02 Part 2 Physical Layer Standards. The same standard is also listed in the FOUNDATION fieldbus specifications under 31.25 Kbps Physical Layer Profile FF-816-1.4. There are essentially four types of cable designations for fieldbus. Type A cable preferred for new installations, because it allows for the most versatile lengths. The other cable types are for installations where cable already exists from 4-20 mA systems. See table 1.

TYPE	CABLE DESCRIPTIONS	CONDUCTOR SIZE	MAXIMUM LENGTH
Type A	Shielded, Twisted Pair	18 AWG	1900 m (6232 ft.)
Type B	Shielded, Multi Twisted Pair	22 AWG	1200 m (3936 ft.)
Type C	Unshielded, Multi Twisted Pair	26 AWG	400 m (1312 ft.)
Type D	Shielded, Untwisted Pair	16 AWG	200 m (656 ft.)

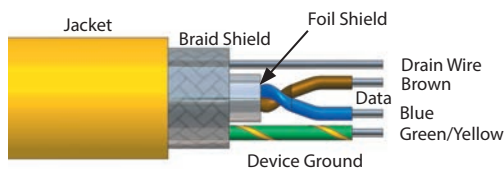

# FOUNDATION™ Fieldbus

TURCK offers type A cables with both two conductors and three conductors, with the third conductor available for a centralized ground of devices if needed. TURCK cables meet or exceed the specifications of ANSI/ISA-SP50.02-1992, the fieldbus standard for use in industrial control systems. The maximum spur length is determined by the number of devices in the segment.

CABLE	NUMBER OF DEVICES	MAXIMUM SPUR LENGTH
Trunk	25-32	0 m (0 ft.)
	19-24	30 m (98 ft.)
	15-18	60 m (197 ft.)
1900 meters	15-18	60 m (197 ft.)
	13-14	90 m (295 ft.)
	2-12	120 m (394 ft.)

## Termination

The FOUNDATION fieldbus communication signal requires that each end of the system be terminated with a 1  $\mu$ F capacitor in series with a 100 W resistor across the communication lines. This termination must be installed at each extreme end of the network segment. Do not use more than two terminators on a communication segment.

## Hazardous Area Usage

FOUNDATION fieldbus networks may be used in hazardous areas as long as required energy limitations for the specific area are observed. One way to achieve this is to use the "entity" concept, which requires the network designer to calculate the voltage and current requirements for each device and determine the system limitations. A simpler option is to use the Fieldbus Intrinsic Safety Concept (FISCO) or Fieldbus Non-Incendive Concept (FNICO). These concepts define the limitations required for devices on a network system to be used in a hazardous area (Class I, Div 1 for FISCO and Class I, Div 2 for FNICO). Many newer FOUNDATION fieldbus devices are rated to meet the requirements of FISCO and/or FNICO. As long as the devices used and the power supply are marked with FISCO or FNICO they may be connected together in the appropriate hazardous area. It is important to note that the cabling used must still meet the defined parameters.

## Using Connectorization

Plug-and-play connectorization has been standard practice for many years in industries ranging from appliance manufacturers to industrial sensors. These industries have found it necessary to compete in a business climate where speed and consistency of connection is king. Connectorization is the perfect complement to fieldbus systems. The concepts and goals are identical: reduce installation time, reduce troubleshooting and easy expansion. The fieldbus system minimizes point-to-point wiring that can be time-consuming and difficult to troubleshoot. Connectorization takes that one step further, almost completely eliminating troubleshooting. Plants that have implemented plug-and play connectorization claim up to a 75 percent reduction in start-up. This directly translates into real cost savings.

## Cost Savings

The initial capital cost is the major factor in selecting a method of connecting devices. These costs include material and installation. The cost of incorporating plug-and-play connectivity will be 10 to 60 percent less. Actual savings will depend on the size and complexity of the installation. Other cost saving factors include reduced design cost, reduced maintenance cost, reduced troubleshooting cost and reduced expansion costs. Some of these cost savings are difficult to determine until the condition exists. However, these costs can quickly change from potential cost savings to real cost savings when the installation begins.

## Design Cost Savings

Most projects begin with a rough definition to develop the capital scope and then progress to detailed development. Development of the capital scope is often expressed in terms of segments, transmitters and tanks. The cabling can be expressed in the same way. Each transmitter requires one device gland and one cordset. Each tank requires one tee, one drop cordset and typically one brick. The home run or trunk cable can run in either conduit or cable tray, so either a field wireable tee or a conduit adapter is required at each tank. A terminating resistor is needed at the beginning and end of the network. A simple estimated bill of materials can be developed as follows:

For: 4 segments, 50 transmitters, 10 tank process

DESCRIPTION	PRODUCT NUMBER	QUANTITY
Device Glands	RSFV 49-0.3M/14.5	50
Cordsets	RSV RKV 490-6M	60 (50 Transmitters + 10 Drops)
Multiport Bricks	JBBS-49SC-M613	10
Field Wireable Tee	SPTT1-A49	10
Terminating Resistor	RSV-49-TR	8
Bulk Cable	CABLE, 490-300M	1

Often for estimating purposes, an average length of cordset and segment length is assumed. In this example, 6 m (20 ft.) cordsets and four 75 m (250 ft.) segments are estimated. The cost and time of coping with continuous changes during the engineering design phase can be very expensive. However, with this model the changes are limited to the length of the cordset and spool of bulk cable. Design changes can even wait until all the transmitters are mounted. Simply taking physical measurements is as valid as any other design method.

## Material Costs

The cost of cordsets and bricks will be slightly lower than the cost of termination in enclosures. The plug-and-play junction bricks are IP67 rated (equivalent NEMA 4X). This means they can be mounted indoors or outdoors without any secondary enclosures. A NEMA 4X enclosure can cost anywhere from \$75 for steel to \$275 for stainless steel. The cost can increase by another \$40 to \$60 for the design and installation time required to put mounting holes in the enclosure and installing cable glands. A cage clamp style termination block costs \$200 to \$450 depending on whether it has short circuit protection. The plug-and-play bricks cost only \$322 and \$486 depending on whether they have short circuit protection. A set of six cordsets costs only \$264 (RSV RKV 490-1M)\*. The material cost comparison for a stainless steel installation is as follows:

FIELD WIRING		PLUG AND PLAY	
NEMA 4X box (Hoffman® or equivalent)	\$ 275	Junction brick (JBBS-49SC-M613)	\$ 486
Cage clamp termination block	450		
Installation of blocks in box	50		
Bulk cable (6 meters)	12	Cordsets (six RSV RKV 490-1M = \$44.00)	264
Device gland (1/2 NPT fitting = \$8.00)	48	Device gland (RSFV 49-0.3M/14.5 = \$30.30)	181
<b>TOTAL</b>	<b>\$ 835</b>	<b>TOTAL</b>	<b>\$ 931</b>

A junction brick system that is completely encapsulated for use indoors or outdoors is equivalent to or approximately 10 percent more expensive than a termination block mounted in an enclosure. The real savings are in the speed and ease of installation.

\* Costs given are examples only, and are subject to change.

## At-A-Glance

### **What is it?**

CANopen is a communication protocol and device profile specification for embedded systems in automation applications

### **What are its basic components?**

Controller, power supply, CAN cable, CANopen I/O nodes and terminating resistors

### **Where is it used?**

Industrial automation, mobile equipment, transportation, medical, military and building automation

### **Who is responsible for it?**

CAN in Automation (CiA), the international users' and manufacturers' organization, develops and supports CAN-based higher-layer protocols

## Overview

CANopen is a higher layer open protocol implemented using the CAN (controller area network) lower level protocol. The CANopen standards, as defined by the CiA (CAN in Automation) organization, are split between communication profiles and device profiles. Communication profiles define the various communication mechanisms and objects used within the CANopen environment. Device profiles provide specific requirements for similar device types from different manufacturers to ensure that the implementation of those devices remains consistent.

## Components

CANopen utilizes an object based structure. Each node stores I/O and parameter data within index locations mapped in the device's OD (object dictionary), as defined by the device profile. These objects can be accessed via SDO (Service Data Object) or PDO (Process Data Object) messages.

## Service Data Object (SDO)

SDO messages are primarily used for node configuration and parameterization. Point-to-point SDO messaging allows access to a single entry in the object dictionary and consists of both a request and response message.

## Process Data Object (PDO)

PDO messages are used to transmit process I/O data. These non-confirmed messages can be configured to transmit multiple data objects, up to 8 bytes, within a single message.

Communication modes available for PDO transmission include:

- **Event Controlled:** The PDO transmission is triggered by COS (Change of State) of data contained within the objects mapped into the PDO
- **Time Driven:** The PDO is generated on a fixed time interval
- **Request Controlled:** Polled PDO transmission occurs in response to a remote request frame from a master or another node
- **Cyclic Synchronized:** Nodes apply output data received and store input data (to be sent as the bus becomes available) upon transmission of a SYNC message. Often used in motion applications, this mode allows process data to be triggered and/or collected from multiple nodes at a single moment in time

The NMT (Network Management) master uses NMT messages to control the operational state of each node (e.g. pre-operational, operational, reset). Heartbeat and node guarding are also functions of NMT messaging.

Data rates available for CANopen include 1Mbit, 800kbps, 500kbps, 250kbps, 125kbps, 50kbps, 20kbps and 10kbps. A maximum of 127 devices are possible on a typical CANopen network (11-bit CAN message identifiers).

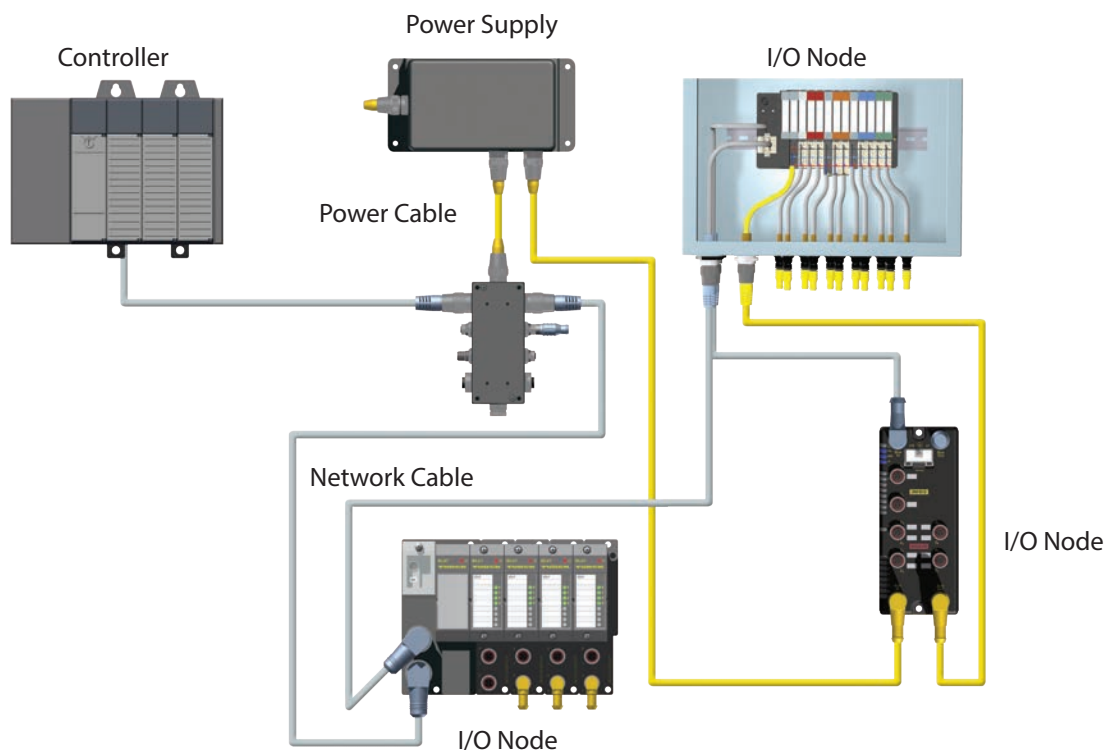

### Basic Parts List:

A typical system consists of the following basic components:

- Controller
- Power Supply
- CAN Cable
- CANopen I/O Nodes
- Terminating Resistors

### Physical Requirements and Maximums

CANopen is implemented based off the trunk and drop topology. It is recommended that a cable be used with 120Ω characteristic impedance. Both ends of the trunk are to be properly terminated with a resistance representing the characteristic impedance of the transmission line (120Ω).

BIT RATE	BUS LENGTH	MAX. DROP LENGTH	ACCUMULATED DROP LENGTH
1 Mbit/s	25 m	1.5 m	7.5 m
800 kbit/s	50 m	2.5 m	12.5 m
500 kbit/s	100 m	5.5 m	27.5 m
250 kbit/s	250 m	11 m	55 m
125 kbit/s	500 m	22 m	110 m
50 kbit/s	1000 m	55 m	275 m
20 kbit/s	2500 m	137.5 m	687.5 m

## Communication Signal

CANopen signals conform to the Controller Area Network (CAN) standard as defined by ISO 11898. The signal type is a differential square wave, allowing for common mode noise rejection.



Oscilloscope capture of the differential CAN signal.  
The CAN high and low components are shown with  
the resulting difference below.

## Cordsets

Although the CANopen specification requires cables to only contain CAN High, CAN Low and a CAN ground conductor, it is also acceptable to include a shield, V+ and V- (device power). The addition of device power bundled within the CAN cable becomes particularly useful within industrial automation as it saves both the added complexity and cost of running separate cables for CAN and device power. TURCK CANopen cables include the required signal conductors, as well as the shield and power pair, with V- also used as the CAN ground.

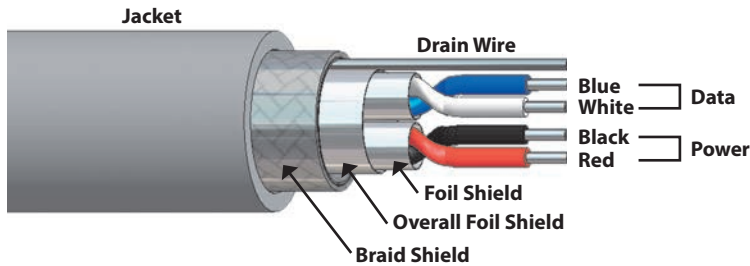

There are many different standardized connectors specified for CANopen (as defined in CiA DR 303-1). TURCK offers cordsets with *minifast*<sup>®</sup> (7/8-16 UN), *eurofast*<sup>®</sup> (M12) and open style options. Cables are available in different physical sizes for more flexibility (thin cable) or longer trunk lengths (thick cable). Cordsets are available in standard lengths, but can also be customized through your local sales representative.

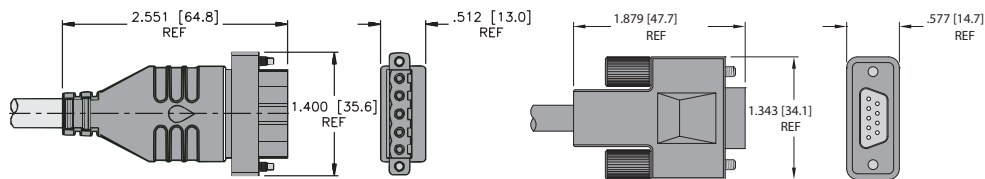
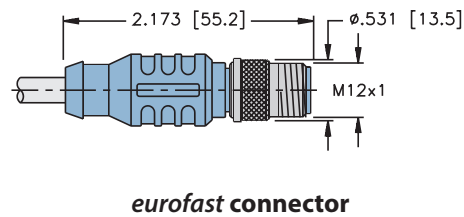
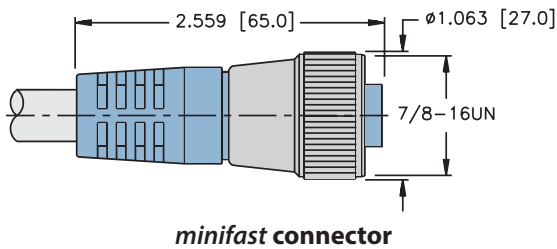

## Open Style Connector

## At-A-Glance

### What is it?

AS-Interface, short for Actuator Sensor Interface, is an industrial networking solution used in PLC, DCS and PC-based automation systems that reliably connects field I/O devices.

### What are its basic components?

One network master (i.e. gateway), network slaves (i.e. input and output modules, one power supply and wiring infrastructure

### Where is it used?

Automation applications, including conveyor control, packaging machines, process control valves, electrical distribution systems, airport carousels and elevators

### Who is responsible for it?

AS-International, a member funded organization located in Germany

## Overview

Actuator Sensor Interface, commonly referred to as AS-interface or AS-i, is a low-level industrial I/O communication protocol. It was originally intended to be a simple, low cost system that would be easy to install and maintain. With that philosophy in mind, the original developers designed AS-i as a discrete-only two-wire system. It incorporated features such as automatic station addressing, and power and data were carried on a single untwisted pair of wires.

As the demand for AS-i grew, so did the demand for more complex devices. The next major version of AS-i, v2.1, extended the protocol to include seamless transfer of analog data, transmission of simple diagnostic data and an extended addressing scheme that effectively doubled the number of stations allowed on the network. The newest version of AS-i, v3.0, has gone even further, allowing more options for analog data and much more detailed diagnostic information to be communicated. New AS-i masters are backwards compatible with nodes from previous versions.

Through the addition of the Safety at Work (SaW) concept to the AS-i specification, it became one of the first industrial protocols to incorporate safety functionality. It is possible to combine both standard I/O along with safety communication and control on a single AS-i network.

AS-interface is usable as a standalone network, or can be used through a gateway as a subnet to a higher level protocol, such as Ethernet-IP or PROFINET. Gateways are a node to the higher level protocol and a master to the AS-i system.

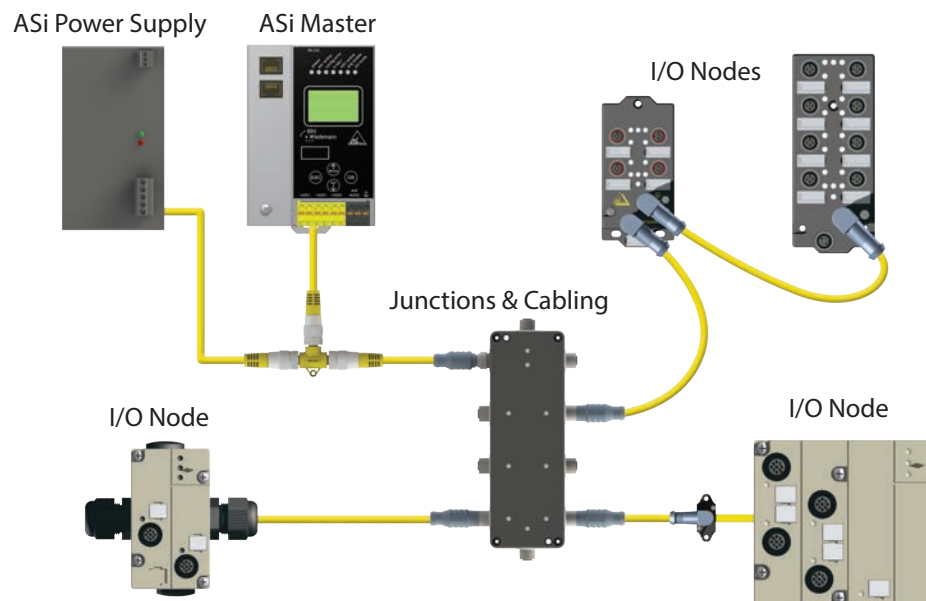

### Typical System Configuration:

#### -Part List:

A typical system consists of the following parts:

- ASi Power Supply
- ASi Master
- I/O Nodes
- Junctions and Cabling

## Maximum Ratings

The AS-i system uses a freeform topology. AS-i segments up to 100m in total length are possible without any termination. Through the use of a network terminator that length is extended to 200m; active tuners alternatively provide up to 300m total length. Only one terminator or tuner may be used in a segment. Further extension is possible with repeaters. No more than two repeaters may be used in a single direction from the master.

## Communication Signal and Power

AS-i communication uses a Manchester II encoded data signal, which results in a very noise immune system. The communication media is a simple two-wire untwisted unshielded cable. Both power and signal are carried over the same pair of conductors. This requires that the DC supply be 'decoupled' from the network to maintain signal integrity. Special AS-i power supplies are available which incorporate the supply and decoupling feature in a single package. Alternatively, a separate AS-i decoupler unit or a gateway with internal decoupling can be used, allowing the use of a standard 30 VDC supply.

In many cases the AS-i power supply is insufficient for devices with higher current requirements (particularly output devices). In these cases most manufacturers provide AS-i nodes that draw I/O current from a separate auxiliary supply. The station electronics are generally still powered from the AS-i bus.

## Addressing

The original AS-i system allowed only 4 bits of data to be transferred in each message for a fast and efficient data transfer system. Nodes could be addressed from 1 to 31, but with the growth of the network more than 31 stations were often required. Beginning with AS-i v2.1 stations were available with extended 'AB' addressing. This scheme allows the station to be addressed from 1A to 31A or 1B to 31B, allowing 62 total nodes with four discrete inputs and three discrete outputs each. The extended address range (and the limitation to three outputs) is achieved by using one output bit for AB selection.

When both A and B addressed nodes are on the same network, they are scanned on alternating cycles (first all the A nodes are scanned, then all the B nodes). Both AB and single-address nodes can be on the same network. In this case the single-address (non-AB) nodes are scanned every cycle. It is important to note that not all v2.1 nodes use the extended addressing scheme.

## Analog Data

Although the original AS-i version only allowed discrete data transfer, v2.1 and higher support seamless analog data transfer. This is accomplished by sending a portion of the analog data on each of several consecutive network cycles; for example, a 16-bit word of data requires seven network cycles. Furthermore, AS-i v3.0 allows analog data transfer in a single cycle by consuming more than one address for the analog node.

## AS-interface® Safety at Work

AS-interface offers the ability to implement communication and control of Safety data up to SIL 3/ Cat. 4 levels. Safety devices can be implemented on the same network with standard I/O. A safety monitor performs the logic for the safety system. These safety monitors are available as an add-on device or as an integrated feature in many gateways. Programming of the monitor is accomplished through the ASIMON software. There are a wide variety of safety input and output nodes available to complete the system.

## Diagnostics

AS-i has limited field diagnostic capability, due to the limited amount of data transferred in each message. With v2.1, a peripheral fault bit can be reported by a particular node to indicate a fault within the device. This allows the user to easily determine the location of a fault down to the node level. AS-i v3.0 supports expanded diagnostic capabilities; allowing asynchronous 'mailbox' messaging for more detailed error information.

## Communication Rate/Cycle Time

AS-i communicates at a fixed data rate of 167 kbps. The cycle time of the system is very predictable because of the simple communication scheme and fixed data rate. A network with 31 nodes will have a cycle time of less than 5ms. A fully loaded network with 62 nodes (all A and B addresses used) will have a cycle time of less than 10ms. If analog nodes are being used, the cycle time of those values will increase as a result of the analog values being spanned across multiple network cycles.

## TURCK & Bihl+Wiedemann

Bihl+Wiedemann is the leading supplier of AS-i master and gateway products. Their broad product range enables users to select from a wide variety of higher level fieldbuses or PC/PLC control solutions. TURCK has partnered with Bihl+Wiedemann to distribute and support their products in North America. Additionally, both Turck and Bihl+Wiedemann offer a variety of analog and discrete AS-i nodes, PCB devices for OEMs, and sophisticated accessory products.

## Cordsets

TURCK offers a complete line of molded AS-i cordsets to facilitate network installation, resulting in a faster start-up and fewer wiring errors. AS-i cables consist of a single untwisted and unshielded wire pair that carries both 30VDC power and the network data. AS-i was originally designed for use with flat cable using an insulation displacement connection, but the use of round cables with sealed connectors has become more common. TURCK provides both cable options.

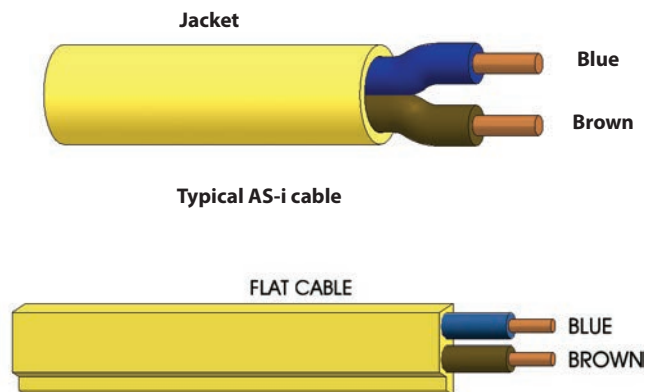

**Notes:**

## At-A-Glance

### What is it?

DeviceNet is a low-level fieldbus network that eliminates hard wiring and connects industrial devices to higher level programmable controllers

### What are its basic components?

Scanner, DeviceNet cables and cordsets, I/O nodes, terminating resistors, power supply and grounding wire

### Where is it used?

Automation, safety devices and large I/O control networks

### Who is responsible for it?

DeviceNet was originally developed by American company Allen-Bradley (now owned by Rockwell Automation).

## Overview

The DeviceNet™ is a low-level fieldbus network that eliminates hard wiring and connects industrial devices such as limit switches, photoelectric sensors, valve manifolds, motor starters, process sensors, bar code readers, variable frequency drives, panel displays and operator interfaces to higher level programmable controllers. It supports 64 nodes, attached to the network in trunkline/dropline topology, as shown on Figure 1. The trunk is the main communication cable that distributes 24VDC power and communication data to all nodes through the DeviceNet media: cables, cordsets, tees, multiport junction boxes, power taps and terminating resistors.

The length of the trunk depends on the data rate and type of cable. The common practice is to use a thick cable for the trunk, whose length is limited to 1,640ft (500 meters). A thin cable is used for the drops. The length of the drop is limited to 20 ft. (6 meter). It is measured from the trunk to the farthest node at the drop. The ends of the trunk are terminated using two 121 Ohm terminating resistors. The network must be grounded at a single location only. Multiple power supply units are allowed but only one of them is grounded. The best location to ground the DeviceNet is in the middle of the network.

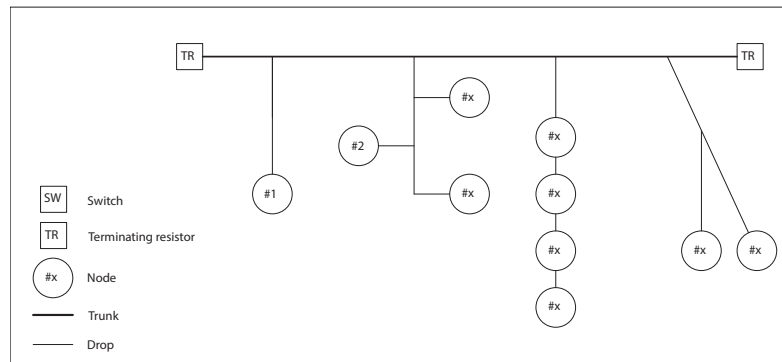

The DeviceNet is a connection-based network. There are two types of connections, the Explicit connections (point-to-point or peer-to-peer) and IO connections. The Explicit messages are used for the network configuration, node commissioning and IO connection initialization. They are determined by a service code (command) and destination designators: Class, Instance and Attribute. Once the command is executed, the connection is closed. The IO connections (Bit-strobe, Poll, Change-of-state/COS and Cyclic) are used for the continuous IO data exchange between a scanner and nodes. All messages are organized in 4 groups, where group 1 has the highest priority on the bus and group 4 the lowest.

Each DeviceNet device has integrated a CAN controller which is used for communication. It generates noise immune, differential, communication signals that carries data over the network. CAN uses a bitwise arbitration method called CSMA/BA (carrier sense multiple access / bitwise arbitration), that assures the highest priority message always gets access to the bus in the event of multiple device requests for data transmission. The CAN stands for the Controller Area Network as defined by the Bosch CAN Specification V2.0 and ISO 11898-1 standard. These standards are the foundation of the Common Industrial Protocol (CIP), the DeviceNet adaptation of CIP (the DeviceNet Specification), by Open DeviceNet Vendor Association, Inc. (ODVA).

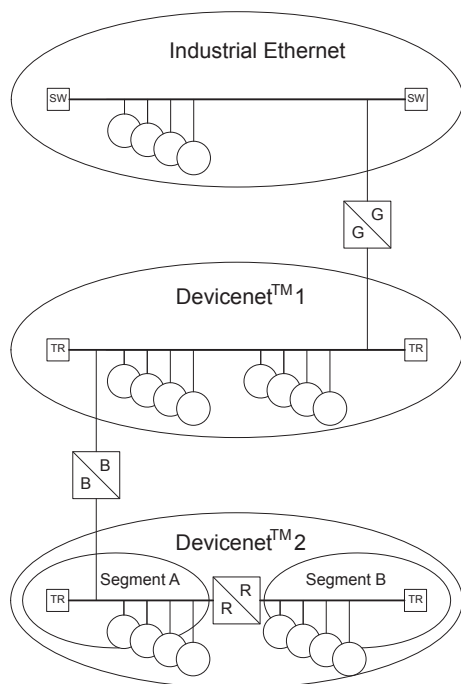

## Interacting With DeviceNet™

There are three levels of interaction involving DeviceNet applications:

**Gateway (G/G)** makes data exchange between DeviceNet and other fieldbus networks possible. They are used as alternative or supplemental devices to reduce the load on the standard networking techniques or to simplify interconnections. A few examples are: DeviceNet/EtherNet IP, DeviceNet/PROFINET and DeviceNet/ASi. A gateway usually appears as a single node on a higher level network and as a scanner on a lower level network. ASi gateway appears as a single node on the DeviceNet and a master on the ASi network.

**Bridge (B/B)** provides simple and the least expensive way to exchange data between two DeviceNet networks. The bridge, also called a Spanner, consists of two DeviceNet nodes which are electrically and optically isolated from each other. Each node is configured with a scanner where it resides. Each node has individual address switches and Autobaud capability. The data size exchanged between bridge nodes is flexible and may be selected during node configuration.

**Repeater (R/R)** or bus extender is used to extend the length of the network drop beyond 20ft limitation. The Repeater may be used to create Y shape network or in a warehouse facility multiple extended drops each up to 1640ft long at 125kB. The DeviceNet design rules apply to the extended network segment (B) the same way as they apply to the main network segment (A). The extended segment must have a separate DeviceNet power supply unit; it must be terminated at both ends and grounded at a single point. Each network segment may have multiple nodes, whose addresses are unique for the entire network. All nodes are set to the same data rate. The total number of nodes on all network segments cannot exceed 64 nodes. The number of the repeaters is not limited; do not cascade repeaters as each one introduces 2ms transmission delay.

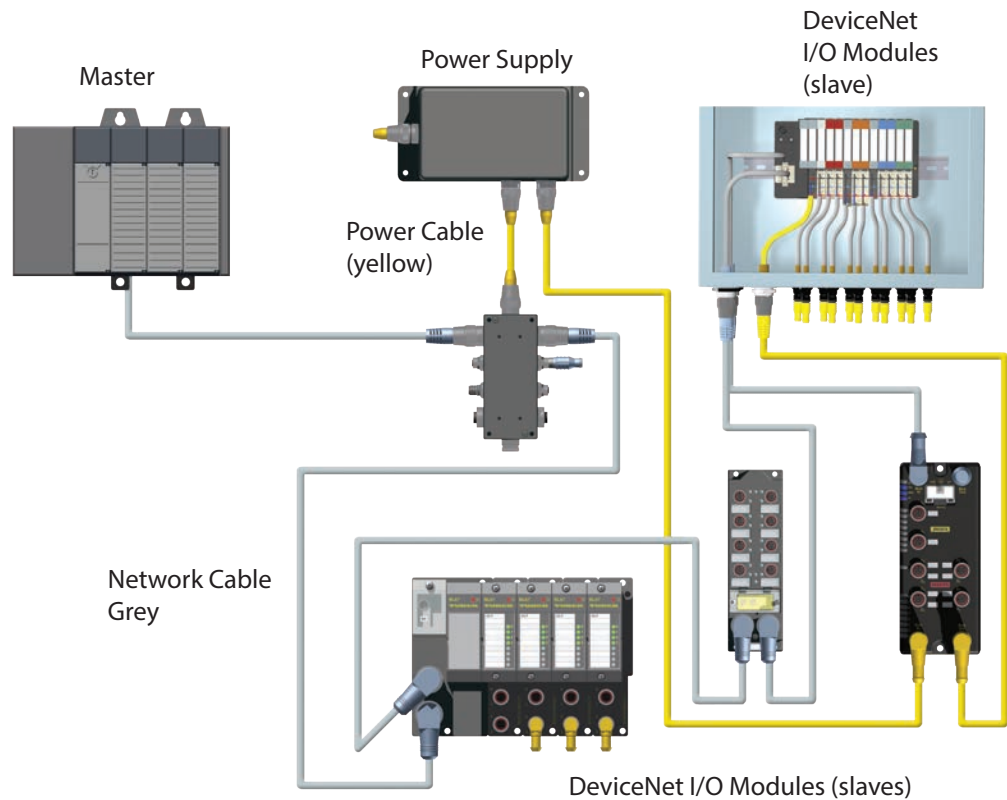

## Basic Parts List

A typical system consists of the following parts:

- Master
- Power Supply
- DeviceNet I/O Modules (slaves)
- Power Cables
- Network Cables

## System Configuration

DeviceNet stations require a network master (also called a scanner) to interface the stations to the host controller. TURCK DeviceNet stations are designed to be fully compatible with DeviceNet equipment from other manufacturers.

## DeviceNet Cables

DeviceNet cables consist of a shielded and twisted data pair, as well as a shielded and twisted power pair for the 24 VDC bus power, with an additional outer shield. The drain wire, together with multiple layers of foil and/or braid that surround data and power pairs, create network shield sufficient to withstand harsh industrial environment. A key benefit of carrying supply voltage in the network cable is that many DeviceNet stations do not need a further supply, allowing the user to only need to run one cable to the station. Some stations, particularly those with high current outputs, can draw too much power from the DeviceNet power supply. These stations typically have an auxiliary power connection, allowing the user to use a second power supply for just the I/O. The bus power supply still powers the DeviceNet communication electronics.

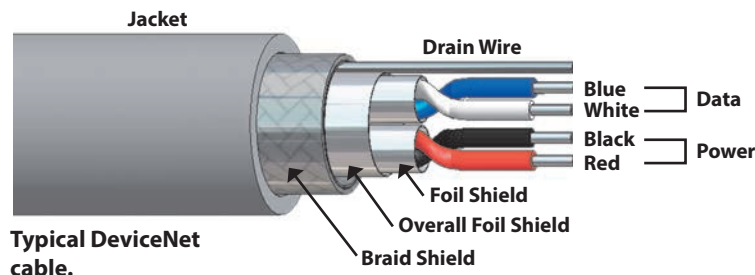

## Cordsets

TURCK offers a complete line of molded DeviceNet™ cordsets to facilitate network installation, resulting in a faster start-up and fewer wiring errors. The bus and drop cables are specially designed foil-shielded, high-flex cables with very low inductance and capacitance to minimize propagation delay time. In most cases, bus cable connections are made using 5-pin *minifast*® (7/8-16 UN) or *euofast*® (M12) connectors. A variety of stations are also available that support terminal-block type connections. TURCK cordsets for the DeviceNet system are available in standard lengths.

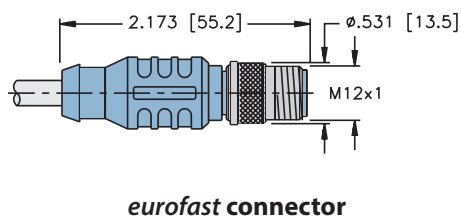
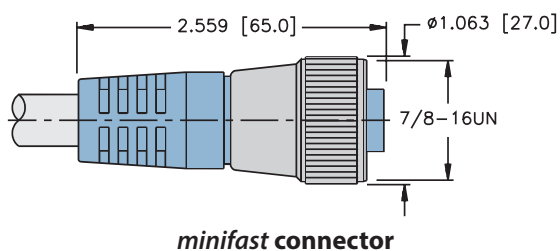

## Network Power

The DeviceNet power may be provided by single or multiple power supply units. The nominal voltage and current rating of all power supply units are: 24VDC +/- 1%, up to 16A continuous feed. The output has to be isolated from AC and a chassis ground. It should be protected against over voltage or over current. The power supply units have a rise time less than 250ms to reach 5% of its rated output voltage. When multiple power supply units are used in an application, V+ is broken between them and only one is grounded.

## Networking Grounding

The DeviceNet is grounded at a single point according to the Figure 4. The shield and the common (V-) of the power supply unit are brought to the same earth-ground point using a copper braid or #8 grounding wire. The shield must be continuous and serves as only protection against electrostatic discharge (ESD) and fast electromagnetic interference transients (EMI), the common source of network communication problems. The location of the grounding point, affects, the same way as location of the power supply unit, a quality of the CAN signal and data transmission. The middle of the network load is considered to be the best possible location for the network grounding.

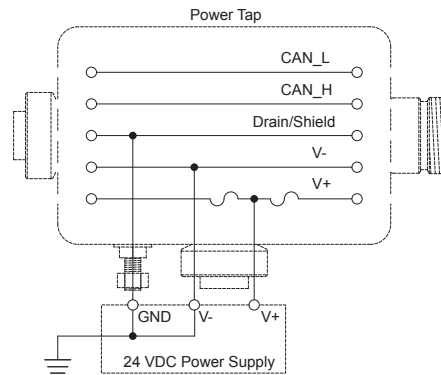

A common mode voltage (CMV) also depends on the location of the network power supply. The higher common mode, more communication errors is generated. The maximum CMV is 9.3V.

## Electronic Data Sheets (EDS) Files

Electronic Data Sheet (EDS) is the DeviceNet configuration file that contains information about a device: identity, I/O data size and the device's configurable parameters. The information provided by EDS files is imported into network configuration tools and guide a user through the steps necessary to configure a device. EDS files are available on [www.turck.com](http://www.turck.com)

## Diagnostics

The DeviceNet stations support different diagnostics information which depends on their complexity and functionality. The common ground for all devices is that they have to provide visual diagnostic information using either a pair of status LEDs called MOD and NET LEDs or use a single combined MOD/NET led. The behavior of these LED is described hereafter.

TURCK discrete IO modules provide diagnostic data as a part of input data map. The standard stations support group diagnostics, where a single alarm bit is set if any IO is faulted. The deluxe station support individual IO diagnostic data, like open wire and short wire alarm bits. All TURCK devices support MOD and NET LED diagnostics as follows:

## MOD – Module Status LED

INDICATES INTERNAL STATUS OF THE DEVICE		
LED COLOR	STATUS	INDICATION
Off	Not Powered	There is no power applied to the device.
Flashing Green	Device in Standby state. Autobaud detection not completed.	<ul style="list-style-type: none"> <li>• Device needs commissioning due to configuration missing, incomplete or incorrect.</li> <li>• Device is not in a scan list. Configure device.</li> <li>• Autobaud detection not completed. Check CAN lines.</li> </ul>
Green	Device Operational	Device operating normally.
Flashing Red	Minor Recoverable Fault	Recoverable fault. For devices with group diagnostic it indicates I/O fault. Check I/O for short.
Red	Major Unrecoverable Fault	The device has an unrecoverable fault; may need replacing.
Flashing Red-Green	Device is powered and in self-test mode.	Self-test mode during power-up sequence.

## NET – Network Status LED

INDICATES INTERNAL STATUS OF THE DEVICE		
LED COLOR	STATUS	INDICATION
Off	Not Powered, Not On-Line	<ul style="list-style-type: none"> <li>• No network power.</li> <li>• Device may not be powered.</li> <li>• Device has not completed DupMacID test yet.</li> </ul>
Flashing Green	On-Line, Not Connected	Device has passed DupMacID test, it is online, device is not allocated to a master. Device is not in a scan list.
Green	Device Operational, On-Line and Connected	Device is configured, connected and communicating.
Flashing Red	Connection Time-Out	One or more I/O connections are in timed out state.
Red	Critical Fault or Critical Link Failure	Failed communication device. The device has detected an error that has rendered it incapable of communicating on the network. Bus-off.
Flashing Red-Green	Device is powered and in self-test mode.	Self-test mode during power-up sequence.

## Addressing

The DeviceNet™ supports 64 nodes, which are assigned addresses from 0 to 63. The address 0 is usually assigned to a scanner, addresses 1 through 61 may be assigned to different nodes, address 62 is reserved for a configuration tool, address 63 must be always free and it is reserved for node commissioning. The station's default node address (out of box) is 63. Each node's address must be initially set, usually via rotary dials or switches on the node. The address can also be set with a DeviceNet configuration tool. Changes to the address settings take effect when the station power is cycled. Every device supports duplicate address detection mechanism (DupMACID) that prevents multiple nodes to occupy the same node address. The DupMACID is run at the device power up. The Device shuts down (goes into bus-off state) when it detects that there is another device at the same node address.

## Data Rate

The data rate or baud rate is the speed of data transmission over the DeviceNet. The DeviceNet operates at three data rates: 125kbps, 250kbps and 500kbps (kilobits per second). All devices must be set to the same data rate in order to have functional network. A failure to do so may result in a critical network fault, forcing entire network or some devices to go into bus-off state. The bus-off state is a state of a device (i.e. CAN chip) when it detects an error that has rendered it incapable of communication on the network.

The data rate is selected using a data rate switch. In general, the switch may have 4 positions marked: 125, 250, 500 and PGM (programmable mode). Instead of the data rate switch, many devices support Autobaud detection mechanism that automatically detects network data rate during power up and sets the device baud rate accordingly. The Autobaud and data rate are supported by the device parameters that can be enabled/disabled and set using the device EDS file (Electronic Data Sheet).

## Network Length

The DeviceNet bus uses trunk and drop topology. The trunk is the main communication cable, and requires a 121 ohm resistor at both ends. The maximum length of the trunk depends on the communication rate and the cable type. Drops are branches off the trunk, and may be from zero to 6 m (20 ft) in length. The cumulative drop lengths are dependent on the communication rate. The following table shows the maximum ratings for a trunk using the most common cable types as defined by the DeviceNet specification.

COMMUNICATION RATE	THICK TRUNK LENGTH (MAXIMUM)	MID TRUNK LENGTH (MAXIMUM)	THIN TRUNK LENGTH (MAXIMUM)	FLAT TRUNK LENGTH (MAXIMUM)	DROP LENGTH (MAXIMUM PER DROP)	DROP LENGTH (CUMULATIVE)
125 kbps	500 m (1640 ft.)	300 m (984 ft.)	100 m (328 ft.)	420 m (1378 ft.)	6 m (20 ft.)	156 m (512 ft.)
250 kbps	250 m (820 ft.)	250 m (820 ft.)	100 m (328 ft.)	200 m (656 ft.)		78 m (256 ft.)
500 kbps	100 m (328 ft.)	100 m (328 ft.)	100 m (328 ft.)	75 m (246 ft.)		39 m (128 ft.)

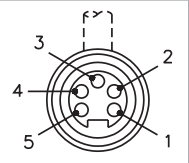
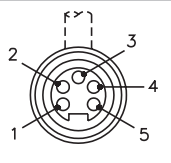
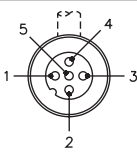
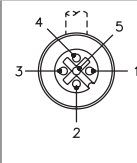
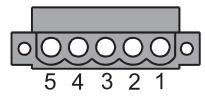
minifast		Pinouts	eurofast		Combicon
Male	Female		Male	Female	Female Front
		<b>1 = Bare (Drain)</b> <b>2 = Red (V+)</b> <b>3 = Black (V-)</b> <b>4 = White (CAN-H)</b> <b>5 = Blue (CAN-L)</b>			 5 4 3 2 1 <b>Female Front</b> <b>1 = Black (-Voltage)</b> <b>2 = Blue (CAN_L)</b> <b>3 = Bare (Shield Drain)</b> <b>4 = White (CAN_H)</b> <b>5 = Red (+Voltage)</b>

## Warranty terms and conditions

### RISK OF LOSS

Delivery of the equipment to a common carrier shall constitute delivery to the Purchaser and the risk of loss shall transfer at that time to Purchaser. Should delivery be delayed due to an act or omission on the part of the Purchaser, risk of loss shall transfer to the Purchaser upon notification by TURCK Inc. that the order is complete and ready for shipment.

### WARRANTIES

TURCK INC. (hereinafter "TURCK") offers five (5) WARRANTIES to cover all products sold. They are as follows:

- 1) The **12-MONTH WARRANTY** is available for the products listed - generally those not covered by **LIFETIME, 5-YEAR, 24-MONTH or 18-MONTH** warranty. No registration required.
- 2) The **18-MONTH WARRANTY** is available for the products listed - generally those not covered by **LIFETIME or 5-YEAR WARRANTY**. No registration is required.
- 3) The **24-MONTH WARRANTY** is available for the products listed - generally those not covered by **LIFETIME, 5-YEAR or 18-MONTH**. No registration is required.
- 4) The **5-YEAR WARRANTY** is available generally for the products listed. No registration is required.
- 5) A **LIFETIME WARRANTY** is available for the products listed. It becomes effective when the accompanying **TURCK LIFETIME WARRANTY REGISTRATION** is completed and returned to TURCK.

### GENERAL TERMS AND CONDITIONS FOR ALL WARRANTIES

- **12-MONTH STANDARD WARRANTY**
- **18-MONTH STANDARD WARRANTY**
- **24-MONTH STANDARD WARRANTY**
- **5-YEAR WARRANTY**
- **LIFETIME WARRANTY**

TURCK warrants the Products covered by the respective WARRANTY AGREEMENTS to be free from defects in material and workmanship under normal and proper usage for the respective time periods listed above from the date of shipment from TURCK. In addition, certain specific terms apply to the various WARRANTIES.

**THESE EXPRESS WARRANTIES ARE IN LIEU OF AND EXCLUDE ALL OTHER REPRESENTATIONS MADE - BOTH EXPRESSED AND IMPLIED. THERE ARE NO WARRANTIES OF MERCHANTABILITY OR OF FITNESS FOR A PARTICULAR PURPOSE FOR PRODUCTS COVERED BY THESE TERMS AND CONDITIONS.**

TURCK warrants that the goods sold are as described, but no promise, description, affirmation of fact, sample model or representation, oral or written shall be part of an order, unless set forth in these terms and conditions, or are in writing and signed by an authorized representative of TURCK. These WARRANTIES do not apply to any Product which has been subject to misuse, negligence, or accident - or to any Product which has been modified or repaired, improperly installed, altered, or disassembled - except according to TURCK's written instructions.

These WARRANTIES are subject to the following conditions:

- 1) These WARRANTIES are limited to the electronic and mechanical performance only, as expressly detailed in the Product specifications and NOT to cosmetic performance.
- 2) These WARRANTIES shall not apply to any cables attached to, or integrated with the Product. However, the **18-MONTH WARRANTY** shall apply to cables sold separately by TURCK.
- 3) These WARRANTIES shall not apply to any Products which are stored, or utilized, in harsh environmental or electrical conditions outside TURCK's written specifications.
- 4) The WARRANTIES are applicable only to Products shipped from TURCK subsequent to January 1, 1988.

ADDITIONAL SPECIFIC TERMS FOR:

**(12-MONTH STANDARD WARRANTY) for Linear Displacement Transducers, Ez Track, RFID Products, Draw Wire Assemblies and Slip Rings.**

**(18-MONTH STANDARD WARRANTY) FOR Q-TRACK INDUCTIVE SENSORS, ULTRASONIC SENSORS, FLOW SENSORS, PRESSURE SENSORS, TEMPERATURE SENSORS, INCLINOMETERS, CABLES AND ALL NON-SENSING PRODUCTS SOLD BY TURCK INC. INCLUDING MULTI-SAFE, MULTI-MODUL, MULTI-CART AND RELATED AMPLIFIER PRODUCTS, RELAYS AND TIMERS.**

**(24-MONTH STANDARD WARRANTY) FOR ENCODERS excluding Draw Wire Assemblies.**

**5-YEAR WARRANTY FOR INDUCTIVE AND CAPACITIVE PROXIMITY SENSORS: The periods covered for the above WARRANTIES and Products shall be 12 MONTHS, 18-MONTHS, 24-MONTHS and 5-YEARS, respectively, from the date of shipment from TURCK.**

**LIFETIME WARRANTY (OPTIONAL - REGISTRATION REQUIRED) FOR INDUCTIVE, INDUCTIVE MAGNET OPERATED AND CAPACITIVE PROXIMITY SENSORS SOLD TO THE ORIGINAL PURCHASER FOR THE LIFETIME OF THE ORIGINAL APPLICATION.**

## Warranty terms and conditions

**The following terms apply to the LIFETIME WARRANTY in addition to the General Terms:**

- 1) This WARRANTY shall be effective only when the LIFETIME WARRANTY REGISTRATION has been completed, signed by the End User and an authorized TURCK Representative or Distributor and has been received by TURCK no later than six (6) months after installation in the End User's Plant, or two (2) years from the date product was shipped from TURCK, whichever is sooner.
- 2) This warranty is available only to TURCK's authorized Representatives, Distributors and to the Original User. (The term "Original User" means that person, firm, or corporation which first uses the Product on a continuous basis in connection with the operation of a production line, piece of machinery, equipment, or similar device.) In the event the ownership of the product is transferred to a person, firm or corporation other than the Original User, this WARRANTY shall terminate.
- 3) This WARRANTY is applicable only to the Original Application. In the event the machinery, equipment, or production line to which the Product is connected, or on which it is installed, is substituted, changed, moved or replaced, the WARRANTY shall terminate.
- 4) This WARRANTY shall be valid only if the Product was purchased by the Original User from TURCK, or from an authorized TURCK Distributor, or was an integral part of a piece of machinery and equipment obtained by the Original user from an Original Equipment Manufacturer, which itself, was purchased directly from TURCK or from an authorized Distributor.

**PURCHASER'S REMEDIES**

This Remedy shall apply to all WARRANTIES. If a TURCK Distributor desires to make a WARRANTY Claim, the Distributor shall, if requested by TURCK, ship the Product to TURCK's factory in Minneapolis, Minnesota, postage or freight prepaid. If the User desires to make a WARRANTY Claim, they shall notify the authorized TURCK Distributor from whom it was purchased or, if such Distributor is unknown, shall notify TURCK. TURCK shall, at its option, take any of the following two courses of action for any products which TURCK determines are defective in materials or workmanship.

- 1) Repair or replace the Product and ship the Product to the Original Purchaser or to the authorized TURCK Distributor, postage or freight prepaid; or
- 2) Repay to the Original Purchaser that price paid by the Original Purchaser; provided that if the claim is made under the LIFETIME WARRANTY, and such Product is not then being manufactured by TURCK, then the amount to be repaid by TURCK to the Original Purchaser shall be reduced according to the following schedule:

<u>Number of Years Since Date of Purchase by Original Purchaser</u>	<u>Percent of Original Purchase Price To Be Paid by TURCK</u>
10	50%
15	25%
20	10%
More than 20	5%

**PURCHASER'S REMEDIES SHALL BE LIMITED EXCLUSIVELY TO THE RIGHT OF REPLACEMENT, REPAIR OR REPAYMENT AS PROVIDED AND DOES NOT INCLUDE ANY LABOR COST OR REPLACEMENT AT ORIGINAL PURCHASER'S SITE. TURCK SHALL NOT BE LIABLE FOR ANY CONSEQUENTIAL DAMAGES RESULTING FROM ANY BREACH OF ANY WARRANTY, EXPRESSED OR IMPLIED, APPLICABLE TO THE PRODUCT, INCLUDING WITHOUT LIMITATION, ANY DAMAGES RESULTING FROM PROPERTY DAMAGE, PERSONAL INJURY OR BUSINESS INTERRUPTION.**

**CONSIDER SAFETY AND PROTECTION PRECAUTIONS**

TURCK takes great care to design and build reliable and dependable products, however, some products can fail eventually. You must take precautions to design your equipment to prevent property damage and personal injury in the unlikely event of failure. As a matter of policy, TURCK does NOT recommend the installation of electronic controls as the sole device FOR THE PROTECTION OF PERSONNEL in connection with power driven presses, brakes, shears and similar equipment and, therefore, the customer should build in redundancy or dual control using approved safety devices for these applications.

---

TURCK Inc. sells its products through Authorized Distributors. These distributors provide our customers with technical support, service and local stock. TURCK distributors are located nationwide - including all major metropolitan marketing areas.

For Application Support or for the location of your nearest TURCK distributor, call:

1-800-544-7769

Specifications in this manual are subject to change without notice. TURCK also reserves the right to make modifications and makes no guarantee of the accuracy of the information contained herein.

# INDEX

ASI-AI-02-M12-V3 BW1893.....E23	BCA-57-M123.....H87	BLCCO-4M12L-2RFID-S-2RFID-S.....E17
ASI-AI-02-M12-V3 BW1963.....E23	BCA-57-M223.....H87	BLCCO-4M12MT-4D0-0.5A-P.....E13
ASI-AI-02RTD-M12-V3 BW1895.....E23	BCA-84-E124.....H30	BLCCO-4M12MT-4D0-2A-P.....E13
ASI-AI-4-M12 BW1359.....E21	BCA-84-E224.....H30	BLCCO-4M12S-4AI-TC.....E19
ASI-AI-4-M12 BW1360.....E21	BIC-44-E424.....H31	BLCCO-4M12S-4AI-VI.....E19
ASI-AI-4PT100-M12 BW2532.....E21	BIC-84-E424.....H31	BLCCO-4M12S-4DI-P.....E13
ASI-A0-4-M12 BW1361.....E21	BK.....H178	BLCCO-4M12S-8XSG-P.....E13
ASI-A0-4-M12 BW1362.....E21	BK 4140-0/9.....H156	BLCCO-6M12L-4AI-VI-2A0-I.....E17
ASI-PM 41.....H173	BK52C 57x-*M.....H53	BLCCO-6M12LT-2RFID-S-8XSG-P.....E17
ASI-PM-1 BW1239.....H173	BKV.....H109	BLCCO-8M12L-4AI-VI-4AI-VI.....E17
B 4140-0/9.....H155	BKV.....H178	BLCCO-8M12L-8DI-P-8DI-P.....E11
B 4141-0/13.5.....H155	BKV 4140-0/11/FF.....H109	BLCCO-8M12LT-4AI-VI-4D0-0.5A-P..E17
B 4151-0/13.5/DNET.....H83	BKV 4140-0/16.....H156	BLCCO-8M12LT-4AI-VI-8XSG-P.....E17
B 4151-0/16/DNET.....H83	BKV 4140-0/9.....H156	BLCCO-8M12LT-4D0-0.5A-P-4D0-0.5A-PE11
B 4151-0/9/DNET.....H83	BL20-B3S-SBB.....B16	BLCCO-8M12LT-8XSG-P-8XSG-P.....E11
B 4251-0/9/DNET.....H83	BL20-B3S-SBC.....B16	BLCCO-8M8S-8XSG-P.....E13
B 8141-0/PG9.....H179	BL20-B3T-SBB.....B16	BLC DN-16M8L-8DI-N-8DI-N.....E11
B 8141-0/PG9.....H157	BL20-B3T-SBC.....B16	BLC DN-16M8L-8DI-P-8DI-P.....E11
B 8151-0/PG9/DNET.....H84	BL20-B4S-SBBC.....B16	BLC DN-16M8L-8XSG-P-8XSG-P.....E11
B 8241-0/PG9.....H179	BL20-B4T-SBBC.....B16	BLC DN-16M8LT-8D0-0.5A-N-8D0-0.5A-NE11
B 8241-0/PG9.....H157	BL20-B6S-SBBSBB.....B16	BLC DN-16M8LT-8D0-0.5A-P-8D0-0.5A-PE11
B 8251-0/PG9/DNET.....H84	BL20-B6S-SBCSBC.....B16	BLC DN-16M8LT-8XSG-P-8XSG-P.....E11
BCA1-F7-44-E124.....H30	BL20-B6T-SBBSBB.....B16	BLC DN-2M12S-2AI-PT.....E19
BCA1-F7-44-E224.....H30	BL20-B6T-SBCSBC.....B16	BLC DN-2M12S-2A0-I.....E19
BCA1-F7-57-M123.....H87	BL20-P3S-SBB.....B15	BLC DN-2M12S-2A0-V.....E19
BCA1-F7-57-M223.....H87	BL20-P3S-SBB-B.....B15	BLC DN-2M12S-2RFID-S.....E19
BCA1-F7-84-E124.....H30	BL20-P3T-SBB.....B15	BLC DN-4M12L-2AI-PT-2AI-PT.....E17
BCA1-F7-84-E224.....H30	BL20-P3T-SBB-B.....B15	BLC DN-4M12L-2A0-I-2A0-I.....E17
BCA-25-E123.....H181	BL20-P4S-SBBC.....B15	BLC DN-4M12L-2RFID-S-2RFID-S.....E17
BCA-25-E223.....H181	BL20-P4S-SBBC-B.....B15	BLC DN-4M12MT-4D0-2A-N.....E13
BCA-25-M123.....H181	BL20-P4T-SBBC.....B15	BLC DN-4M12MT-4D0-2A-P.....E13
BCA-25-M223.....H181	BL20-P4T-SBBC-B.....B15	BLC DN-4M12S-4AI4A0-VI.....E19
BCA-25SC-E123.....H181	BL20-S3S-SBB.....B15	BLC DN-4M12S-4AI-VI.....E19
BCA-25SC-E223.....H181	BL20-S3S-SBC.....B15	BLC DN-4M12S-4A0-V.....E19
BCA-44-E124.....H30	BL20-S3T-SBB.....B15	BLC DN-6M12L-4AI4A0-VI-4DI-P.....E17
BCA-44-E224.....H30	BL20-S3T-SBC.....B15	BLC DN-6M12L-4AI-VI-2A0-I.....E17
BCA-45-E123.....H162	BL20-S4S-SBBC.....B15	BLC DN-6M12LT-2RFID-S-8XSG-PD...E17
BCA-45-E223.....H162	BL20-S4S-SBBS.....B15	BLC DN-8M12L-4AI-TC-4AI-TC.....E17
BCA-48-E123.....H158	BL20-S4S-SBBS-CJ.....B15	BLC DN-8M12L-4AI-VI-4AI-VI.....E17
BCA-48-E223.....H158	BL20-S4S-SBCS.....B15	BLC DN-8M12L-8DI-P-8DI-N.....E11
BCA-48-M123.....H158	BL20-S4T-SBBC.....B15	BLC DN-8M12LT-4AI-VI-8XSG-PD.....E17
BCA-48-M223.....H158	BL20-S4T-SBBS.....B15	BLC DN-8M12LT-4D0-2A-N-4D0-2A-N..E11
BCA-48SC-M123.....H158	BL20-S4T-SBBS-CJ.....B15	BLC DN-8M12LT-4D0-2A-P-4D0-2A-P..E11
BCA-48SC-M223.....H158	BL20-S4T-SBCS.....B15	BLC DN-8M12LT-8DI-N-8D0-0.5A-N..E11
BCA-49-E123.....H110	BL20-S6S-SBBSBB.....B15	BLC DN-8M8S-8DI-N.....E13
BCA-49-E223.....H110	BL20-S6S-SBCSBC.....B15	BLC DN-8M8S-8DI-P.....E13
BCA-49-M123.....H110	BL20-S6T-SBBSBB.....B15	BLC DP-1M12MT-1SSI.....E21
BCA-49-M223.....H110	BL20-S6T-SBCSBC.....B15	BLC DP-2M12MT-2RFID-S.....E21
BCA-49SC-M123.....H110	BLCCO-16M8LT-8XSG-P-8XSG-P.....E11	BLC DP-4M12LT-2AI-PT-2AI-PT.....E17
BCA-49SC-M223.....H110	BLCCO-2M12S-2A0-V.....E19	BLC DP-4M12MT-4AI4A0-VI.....E21
BCA-57-E123.....H87	BLCCO-2M12S-2RFID-S.....E19	BLC DP-4M12MT-4AI-TC.....E21
BCA-57-E223.....H87	BLCCO-4M12L-2AI-PT-2AI-PT.....E17	BLC DP-4M12MT-4AI-VI.....E21

# DISTRIBUTED I/O SALES GUIDE



BLCDP-4M12MT-4A0-V.....E21	BSV.....H109	FDNQ-S0404G-MM.....E11
BLCDP-6M12LT-2AI-PT-8XSG-PD.....E19	BSV.....H178	FDNQ-S0404G-T.....E11
BLCDP-6M12LT-2A0-I-8XSG-PD.....E19	BSV 4140-0/11/FF.....H109	FDNQ-S0800-T.....E11
BLCDP-6M12LT-2A0-V-8XSG-PD.....E19	BSV 4140-0/16.....H156	FDNQ-XSG08-T.....E11
BLCDP-6M12LT-2RFID-S-8XSG-PD...E19	BSV 4140-0/9.....H156	FGEN-IM16-4001.....E7
BLCDP-8M12LT-4AI-VI-4AI-VI.....E19	CBC5 57x-*M.....H53	FGEN-IM16-5001.....E7
BLCDP-8M12LT-4AI-VI-8XSG-PD.....E19	CMBD 8141-0/PG9.....H29,	FGEN-IOM88-4001.....E7
BLCEN-16M8LT-8XSG-P-8XSG-P.....E11	CMBD 8241-0/PG9.....H29,	FGEN-IOM88-5001.....E7
BLCEN-1M12MT-1RS232.....E21	CMBSD 8141-0/PG9.....H29,	FGEN-OM16-4001.....E7
BLCEN-1M12MT-1RS485-422.....E21	CMBSD 8241-0/PG9.....H29,	FGEN-OM16-5001.....E7
BLCEN-1M12MT-1SSI.....E21	Connector, FW, RJ45S 84 IDC....H28	FGEN-XSG16-4001.....E7
BLCEN-2M12MT-2AI-PT.....E21	Connector, FW, RJ45S 86 IDC CAT 6H28	FGEN-XSG16-5001.....E7
BLCEN-2M12MT-2RFID-S.....E21	Connector, RJ45S 42 IDC.....H42	FK 25-*M.....H177
BLCEN-3M12LT-1RS232-2RFID-S.....E17	Connector, RJ45S IDC.....H28	FK 25-*M/14.5.....H176
BLCEN-4M12LT-2AI-PT-2AI-PT.....E17	Connector, PDP, D9S.....H132	FK 25-*M/14.75.....H176
BLCEN-4M12LT-2RFID-S-2RFID-S...E17	Connector, PDP, D9SM.....H132	FK 25-*M/M20.....H176
BLCEN-4M12MT-4AI4A0-VI.....E21	Connector, PDP, SD9S.....H132	FK 45 PCB.....H136
BLCEN-4M12MT-4AI-TC.....E21	D9S 45x-*M.....H131	FK 57-*M.....H79
BLCEN-4M12MT-4AI-VI.....E21	D9S/T 45x-*M.....H130	FK 57-*M/14.5.....H78
BLCEN-4M12MT-4A0-V.....E21	D9SM 45x-*M.....H131	FK 57-*M/14.75.....H78
BLCEN-4M12MT-8DI-P.....E13	D9SM/T 45x-*M.....H130	FK 57-*M/M20.....H78
BLCEN-4M12MT-8DO-0.5A-P.....E13	DPC-49-1RMB.....H119	FK 57-PCB.....H81
BLCEN-6M12LT-2RFID-S-8XSG-P.....E17	DPC-49-4RMB.....H121	FK 57-PCB KIT.....H81
BLCEN-6M12LT-4AI-VI-2A0-I.....E17	DPC-49-4RMB/YO.....H121	FK 84-PCB.....H18
BLCEN-8M12LT-4AI4A0-VI-4AI4A0-VIE17	DPC-49-ADU.....H119	FK 84-PCB KIT.....H18
BLCEN-8M12LT-4AI-VI-4AI-VI.....E17	DPC-49-BM-DPC.....H119	FKD FKD 44/M12.....H27
BLCEN-8M8MT-8XSG-P.....E13	DPC-49-DU.....H119	FKFD 25x-*M.....H168
BLCEN-IP-8M12LT-4AI-TC-4AI-TC...E17	DPC-49-HSEFD/24VDC.....H121	FKFD 57-PCB.....H82
BMSWS 8151-8.5/PDP.....H139	DPC-49-IPS1.....H119	FKFD 57x-*M.....H50
BMSWS 8251-8.5/PDP.....H139	FAS4-CSG43-A.....E15	FKFD 84-PCB.....H19
BMWS 8151-8.5/PDP.....H139	FAS4-CSG44.....E15	FKFD 84x-*M.....H11
BMWS 8251-8.5/PDP.....H139	FAS4-CSG44-A.....E15	FKFD BK52C 57x-*M.....H54
BPA-25-M113.....H181	FAS4-S0003G-A.....E15	FKFD CBC5 57x-*M.....H54
BPA-44-E113.....H31	FAS4-S0400.....E15	FKFDD 44x-*M.....H21
BPA-45-E113.....H161	FAS8-S0404G-A.....E15	FKFDL 57.....H82
BPA-49-M113.....H111	FAS8-S0404H-A.....E15	FKFDL 84.....H19
BPA-57-E113.....H87	FDN-DN1.....G5	FKFDLW 45.....H135
BPA-57-M113.....H87	FDNL-CSG88-W.....E5	FKFDV 48x-*M.....H144
BPA-84-E113.....H31	FDNL-L1600-T.....E5	FKFDV 49x-*M.....H96
BS.....H178	FDNL-N1600-T.....E5	FKFDW 45 PCB.....H135
BS 4140-0/9.....H155	FDNL-S0808HI-MM.....E5	FKM FS 57/M12.....H64
BS 4141-0/13.5.....H155	FDNL-S1600-T.....E5	FKSDD RJ45SF 44.....H27
BS 4151-0/13.5/DNET.....H83	FDNL-S1600-W.....E5	FKSDD RJ45SF 44/ST.....H27
BS 4151-0/16/DNET.....H83	FDNL-SN0808N-C.....E5	FKSDE 84x-*M.....H13
BS 4151-0/9/DNET.....H83	FDNL-XSG16-T.....E5	FKSDED 42x-*M.....H37
BS 4251-0/9/DNET.....H83	FDNP-L0808H-TT.....E7	FKSDED 44x-*M.....H23
BS 8141-0/PG9.....H179	FDNP-P0808H-TT.....E7	FKSDWE D9S FKSDWE 45x-*M-*M...H131
BS 8141-0/PG9.....H157	FDNP-S0808G-TT.....E7	FKSDWE D9S/T 45x-*M.....H130
BS 8151-0/PG9/DNET.....H84	FDNP-S0808G-WW.....E7	FKSDWE D9SM/T 45x-*M.....H130
BS 8241-0/PG9.....H179	FDNP-S0808H-WW.....E7	FKSDWE SD9S FKSDWE 45x-*M-*M...H131
BS 8241-0/PG9.....H157	FDNP-XSG16-ST.....E7	FKSDWE SD9S/T 45x-*M.....H130
BS 8251-0/PG9/DNET.....H84	FDNP-XSG16-TT.....E7	FKV 48-*M.....H150

# INDEX

FKV 48-*M/14.5.....	H149	FSSDWE SD9S FSSDWE 45x-*M-*M...H131	JBBS-49SC-E413.....	H112	
FKV 48-*M/14.75.....	H149	FSSDWE SD9S/T 45x-*M.....H130	JBBS-49SC-E613.....	H112	
FKV 48-*M/M20.....	H149	FSSDWE SD9S/T 45x-*M-*M.....H131	JBBS-49SC-E813.....	H112	
FKV 49-*M.....	H108	FSV 49-*M.....	H108	JBBS-49SC-M413.....	H112
FKV 49-*M/14.5.....	H107	FSV 49-*M/14.5.....	H107	JBBS-49SC-M613.....	H112
FKV 49-*M/14.75.....	H107	FSV 49-*M/14.75.....	H107	JBBS-49SC-M653.....	H114
FKV 49-*M/M20.....	H107	FSV 49-*M/M20.....	H107	JBBS-49SC-M813.....	H112
FKV FSV 48/M12.....	H151	FSW 45 PCB.....	H136	JBBS-49SC-M853.....	H114
FKV FSV 49/M12.....	H101	FSW 45 PCB KIT.....	H136	JBBS-57-E1001.....	H88
FKW 45 PCB KIT.....	H136	FXDP-IM 16-0001.....	E7	JBBS-57-E1021.....	H89
FKW FSW 45/M12.....	H137	FXDP-IOM 88-0001.....	E7	JBBS-57-E401.....	H88
FLDP-IM 16-0001.....	E7	FXDP-OM 16-0001.....	E7	JBBS-57-E421.....	H90
FLDP-IM 32-0001.....	E9	FXDP-XSG16-0001.....	E7	JBBS-57-E601.....	H88
FLDP-IOM 1616-0001.....	E9	IM82-24-10.....	G15	JBBS-57-E621.....	H89
FLDP-IOM 88-0002.....	E7	IM82-24-2.5.....	G12	JBBS-57-E801.....	H88
FLDP-OM 16-0001.....	E7	IM82-24-20.....	G15	JBBS-57-E811.....	H89
FS 25-*M.....	H177	IM82-24-5.0.....	G13	JBBS-57-E821.....	H89
FS 25-*M/14.5.....	H176	JBBS-25-E413.....	H182	JBBS-57-FS-E424.....	H90
FS 25-*M/14.75.....	H176	JBBS-25-E613.....	H182	JBBS-57-M401.....	H88
FS 25-*M/M20.....	H176	JBBS-25-E813.....	H182	JBBS-57-M601.....	H88
FS 57-*M.....	H79	JBBS-25-M413.....	H182	JBBS-57-M801.....	H88
FS 57-*M/14.5.....	H78	JBBS-25-M613.....	H182	JBBS-57-T601.....	H88
FS 57-*M/14.75.....	H78	JBBS-25-M813.....	H182	JBBS-57-T801.....	H88
FS 57-*M/M20.....	H78	JBBS-25SC-E613/SO.....	H182	JRBS-25-10R.....	H183
FS 57-PCB.....	H81	JBBS-25SC-E813/SO.....	H182	JRBS-25-12R.....	H183
FS 57-PCB KIT.....	H81	JBBS-25SC-M613/SO.....	H182	JRBS-25-4R.....	H184
FS 84-PCB.....	H18	JBBS-25SC-M813/SO.....	H182	JRBS-25-6R.....	H184
FS 84-PCB KIT.....	H18	JBBS-48-E413.....	H160	JRBS-25-8R.....	H183
FSFD 25x-*M.....	H168	JBBS-48-E613.....	H159	JRBS-49SC-10R.....	H115
FSFD 57-PCB.....	H82	JBBS-48-E813.....	H159	JRBS-49SC-12R.....	H115
FSFD 57x-*M.....	H50	JBBS-48-M413.....	H160	JRBS-49SC-4R.....	H116
FSFD 84-PCB.....	H19	JBBS-48-M613.....	H159	JRBS-49SC-6R.....	H116
FSFD 84x-*M.....	H11	JBBS-48-M813.....	H159	JRBS-49SC-8R.....	H115
FSFD BK52C 57x-*M.....	H54	JBBS-48SC-E413.....	H159	JRBS-57-4.....	H91
FSFD CBC5 57x-*M.....	H54	JBBS-48SC-E613.....	H159	JRBS-57-6.....	H91
FSFDD 44x-*M.....	H21	JBBS-48SC-E813.....	H159	JRBS-57-8.....	H91
FSFDL 57.....	H82	JBBS-48SC-M413.....	H159	JRBS-57VM-4.....	H91
FSFDL 84.....	H19	JBBS-48SC-M613.....	H159	JRBS-57VM-6.....	H91
FSFDLW 45.....	H135	JBBS-48SC-M653.....	H160	JRBS-57VM-8.....	H91
FSFDV 48x-*M.....	H144	JBBS-48SC-M813.....	H159	MBD40-T0415/EX/000.....	H123
FSFDV 49x-*M.....	H96	JBBS-48SC-M853.....	H160	MBD40-T0815/EX/000.....	H123
FSFDW 45 PCB.....	H135	JBBS-49-E413.....	H112	MT-RKM/RSM/RKM 57/DNET/VM.....	H69
FSSDE 84x-*M.....	H13	JBBS-49-E423.....	H114	MT-RSM/2RKM 57/DNET.....	H70
FSSDED 42x-*M.....	H37	JBBS-49-E623.....	H113	MT-RSM/2RKM 57/DNET/VM.....	H69
FSSDED 44x-*M.....	H23	JBBS-49-E813.....	H112	PB-XEPI2.....	G7
FSSDWE D9S FKSDWE 45x-*M-*M...H131		JBBS-49-E823.....	H113	PDA67-IDENT-INT-HF.....	F14
FSSDWE D9S FSSDWE 45x-*M-*M...H131		JBBS-49-M413.....	H112	PD-IDENT-HF-RBSUP.....	F14
FSSDWE D9S/T 45x-*M.....H130		JBBS-49-M423.....	H114	PD-IDENT-HF-RBTW.....	F14
FSSDWE D9SM FKSDWE 45x-*M-*M...H131		JBBS-49-M613.....	H112	PD-IDENT-UHF-RBTW-915-920.....	F14
FSSDWE D9SM FSSDWE 45x-*M-*M...H131		JBBS-49-M623.....	H113	PD-IDENT-WLAN.....	F14
FSSDWE D9SM/T 45x-*M.....H130		JBBS-49-M813.....	H112	PDP-Connector/SD9S.....	H133
FSSDWE SD9S FKSDWE 45x-*M-*M...H131		JBBS-49-M823.....	H113	PDP-TRA.....	H134

# DISTRIBUTED I/O SALES GUIDE



PKG 5M PKG 5M-57x.....H58	RB50652-*M.....H48	RJ45IP67 84x.....H12
PKG 5M PKW 5M-57x.....H58	RB50672-*M.....H127	RJ45IP67 FKFD 84x-*M.....H11
PKG 5M PSG 5M-57x.....H58	RB50683-*M.....H127	RJ45IP67 FKFD 44x-*M.....H21
PKG 5M PSW 5M-57x.....H58	RB50692-*M.....H127	RJ45IP67 FSFD 84x-*M.....H11
PKG 5M RKT 57x*M.....H58	RB50708-*M.....H127	RJ45IP67 FSFD 44x-*M.....H21
PKG 5M RST 57x*M.....H58	RB50721-*M.....H47	RJ45IP67 RJ45IP67 44x-*M.....H22
PKG 5M WKT 57x*M.....H58	RB50764-*M.....H46	RJ45IP67 RJ45IP67 84x.....H12
PKG 5M WST 57x*M.....H58	RB50785-*M.....H94	RJ45IP67 RJ45MIP67 44x-*M.....H22
PKG 5M-57x.....H58	RB50785-*M.....H142	RJ45IP67 RJ45MIP67 84x-*M.....H12
PKG 5Z 57x-*M.....H59	RB50786-*M.....H142	RJ45MIP67 44x-*M.....H22
PKG 5Z PKGZ 5Z 57x-*M.....H59	RB50793-*M.....H48	RJ45MIP67 84x-*M.....H12
PKG 5Z PSG 57x-*M.....H59	RB50803-*M.....H142	RJ45MIP67 FKFD 84x-*M.....H11
PKG 5Z RKT 57x-*M.....H59	RB50860-*M.....H142	RJ45MIP67 FKFD 44x-*M.....H21
PKG 5Z RST 57x-*M.....H59	RB50876-*M.....H47	RJ45MIP67 FSFD 84x-*M.....H11
PKG 5Z WKT 57x-*M.....H59	RB50877-*M.....H47	RJ45MIP67 FSFD 44x-*M.....H21
PKG 5Z WST 57x-*M.....H59	RB50881-*M.....H127	RJ45MIP67 RJ45IP67 84x.....H12
PKW 5M PKW 5M-57x.....H58	RB50891-*M.....H94	RJ45MIP67 RJ45MIP67 44x-*M.....H22
PKW 5M PSG 5M-57x.....H58	RB50929-*M.....H142	RJ45MIP67 RJ45MIP67 84x-*M.....H12
PKW 5M PSW 5M-57x.....H58	RB51045-*M.....H57	RJ45S 42x-*M.....H38
PKW 5M RKT 57x*M.....H58	RB51057-*M.....H127	RJ45S 44x-*M.....H24
PKW 5M RST 57x*M.....H58	RB51106-*M.....H48	RJ45S 84x-*M.....H14
PKW 5M WKT 57x*M.....H58	RB51210-*M.....H20	RJ45S FKSDE 84x-*M.....H13
PKW 5M WST 57x*M.....H58	RB51211-*M.....H20	RJ45S FKSDED 42x-*M.....H37
PKW 5M-57x.....H58	RB51212-*M.....H20	RJ45S FKSDED 44x-*M.....H23
PSG 5 57x-*M.....H59	RB51213-*M.....H20	RJ45S FSSDE 84x-*M.....H13
PSG 5 PSG 5 57x-*M.....H59	RB51225-*M.....H127	RJ45S FSSDED 42x-*M.....H37
PSG 5 RKT 57x-*M.....H59	RB51231-*M.....H48	RJ45S FSSDED 44x-*M.....H23
PSG 5 RST 57x-*M.....H59	RB51235-*M.....H47	RJ45S RJ45S 42x-*M.....H38
PSG 5 WKT 57x-*M.....H59	RB51240-*M.....H173	RJ45S RJ45S 44x-*M.....H24
PSG 5 WST 57x-*M.....H59	RB51241-*M.....H173	RJ45S RJ45S 84x-*M.....H14
PSG 5M PSG 5M-57x.....H58	RB51242-*M.....H173	RJ45S RJ45SMIP67 42x-*M.....H38
PSG 5M PSW 5M-57x.....H58	RB51296-*M.....H46	RJ45S RJ45SMIP67 44x-*M.....H24
PSG 5M RKT 57x*M.....H58	RB51300-*M.....H94	RJ45SMIP67 42x-*M.....H38
PSG 5M RST 57x*M.....H58	RB51822-*M42 lbs.....H173	RJ45SMIP67 44x-*M.....H24
PSG 5M WKT 57x*M.....H58	RB51916-*M.....H46	RJ45SMIP67 84x-*M.....H14
PSG 5M WST 57x*M.....H58	REP-DN.....G5	RJ45SMIP67 FKFD 84x-*M.....H23
PSG 5M-57x.....H58	REP-DP-0002.....G7	RJ45SMIP67 FKSDE 84x-*M.....H13
PSU67-11-1240/M.....G10	RJ45 44x-*M.....H22	RJ45SMIP67 FKSDED 42x-*M.....H37
PSU67-11-2420/M.....G10	RJ45 84x-*M.....H12	RJ45SMIP67 FSFD 84x-*M.....H23
PSU67-11-2440/M.....G10	RJ45 FKFD 84x-*M.....H11	RJ45SMIP67 FSSDE 84x-*M.....H13
PSU67-11-2480/M.....G12	RJ45 FKFD 44x-*M.....H21	RJ45SMIP67 FSSDED 42x-*M.....H37
PSU67-12-2480/M.....G12	RJ45 FSFD 84x-*M.....H11	RJ45SMIP67 RJ45S 42x-*M.....H38
PSW 5M PSW 5M-57x.....H58	RJ45 FSFD 44x-*M.....H21	RJ45SMIP67 RJ45SMIP67 42x-*M.....H38
PSW 5M RKT 57x*M.....H58	RJ45 RJ45 44x-*M.....H22	RJ45SMIP67 RJ45SMIP67 44x-*M.....H24
PSW 5M RST 57x*M.....H58	RJ45 RJ45 840-3FT/ECON.....H17	RJ45SMIP67 RJ45SMIP67 84x-*M.....H14
PSW 5M WKT 57x*M.....H58	RJ45 RJ45 840-7FT/ECON.....H17	RJ45SMIP67 WRJ45ES 42x-*M.....H38
PSW 5M WST 57x*M.....H58	RJ45 RJ45 84x-*M.....H12	RJ45SS RJ45SMIP67 84x-*M.....H14
PSW 5M-57x.....H58	RJ45 RJ45IP67 44x-*M.....H22	RKC 25x-*M.....H168
RB50603-*M.....H46	RJ45 RJ45IP67 84x.....H12	RKC 2RSC 25.....H171
RB50629-*M.....H46	RJ45 RJ45MIP67 44x-*M.....H22	RKC 57x-*M.....H50
RB50633-*M.....H48	RJ45 RJ45MIP67 84x.....H12	RKC 84x-*M.....H11
RB50651-*M.....H46	RJ45IP67 44x-*M.....H22	RKC BK52C 57x-*M.....H54

# INDEX

RKC CBC5 57x-*M.....H54	RKF 57-*M/M20.....H76	RKSD 42x-*M.....H37
RKC FKFD 25x-*M.....H168	RKF 57-PCB.....H80	RKSD 44x-*M.....H23
RKC FKFD 57x-*M.....H52	RKFP 25x-*M.....H168	RKSD FKSD 42x-*M.....H37
RKC FKFD 84x-*M.....H11	RKFP 57x-*M.....H50,	RKSD FKSD 44x-*M.....H23
RKC FSFD 25x-*M.....H168	RKFP BK52C 57x-*M.....H54	RKSD FSSDED 42x-*M.....H37
RKC FSFD 57x-*M.....H52	RKFP CBC5 57x-*M.....H54	RKSD FSSDED 44x-*M.....H23
RKC FSFD 84x-*M.....H11	RKFPV 48x-*M.....H144	RKSD RJ45S 42x-*M.....H38
RKC RJ45 84x-*M.....H12	RKFPV 49x-*M.....H96	RKSD RJ45S 44x-*M.....H24
RKC RJ45IP67 84x.....H12	RKFV 48-*M.....H148	RKSD RJ45SMIP67 42x-*M.....H38
RKC RJ45MIP67 84x.....H12	RKFV 48-*M/14.5.....H147	RKSD RJ45SMIP67 44x-*M.....H24
RKC RKC 25x-*M.....H168	RKFV 48-*M/14.75.....H147	RKSD RKSD 42x-*M.....H37
RKC RKC 57x-*M.....H51	RKFV 48-*M/M20.....H147	RKSD RKSD 44x-*M.....H23
RKC RKC 84x-*M.....H11	RKFV 49-*M.....H106	RKSD WKSD 44x-*M.....H23
RKC RKFP 25x-*M.....H168	RKFV 49-*M/14.5.....H105	RKSD WRJ45ES 42x-*M.....H38
RKC RKFP 57x-*M.....H52	RKFV 49-*M/14.75.....H105	RKSD WRJ45ES 44x-*M.....H24
RKC RSFP 25x-*M.....H168	RKFV 49-*M/M20.....H105	RKSS FSSDE 84x-*M.....H13
RKC RSFP 57x-*M.....H52	RKGV 49x-*M.....H99	RKSW.....H134
RKC WKC 25x-*M.....H168	RKM 25x-*M.....H167	RKSW 2RSSW 45.....H138
RKC WKC 57x-*M.....H51	RKM 57-TR2.....H62	RKSW 2RSSW 45-0001.....H138
RKC WKC 84x-*M.....H11	RKM 57x-*M.....H49	RKSW 45x-*M.....H128
RKC WRJ45E 84x-*M.....H12	RKM BK52C 57x-*M.....H53	RKSW D9S RKSW 45x-*M-*M.....H131
RKCD RJ45MIP67 44x-*M.....H22	RKM CBC5 57x-*M.....H53	RKSW D9S/T 45x-*M.....H130
RKCD 44x-*M.....H21	RKM FKFD 25x-*M.....H168	RKSW D9SM RKSW45x-*M-*M.....H131
RKCD FKFD 44x-*M.....H21	RKM FKFD 57x-*M.....H50	RKSW D9SM/T 45x-*M.....H130
RKCD FSFD 44x-*M.....H21	RKM FSFD 25x-*M.....H168	RKSW RKSW 45x-*M.....H128
RKCD RJ45 44x-*M.....H22	RKM FSFD 57x-*M.....H50	RKSW SD9S RKSW 45x-*M-*M.....H131
RKCD RJ45IP67 44x-*M.....H22	RKM RKC 25x-*M.....H168	RKSW SD9S/T 45x-*M.....H130
RKCD RKCD 44x-*M.....H21	RKM RKC 57x-*M.....H50	RKSW WKS 45x-*M.....H128
RKCD WRJ45E 44x-*M.....H22	RKM RKFP 25x-*M.....H168	RKT 57x-*.....H58,
RKCV 48x-*M.....H144	RKM RKFP 57x-*M.....H50	RKV 48x-*M.....H143
RKCV 49x-*M.....H96	RKM RKM 25.....H172	RKV 49x-*M.....H95
RKCV FKFDV 48x-*M.....H144	RKM RKM 25x-*M.....H167	RKV FKFDV 48x-*M.....H144
RKCV FKFDV 49x-*M.....H96	RKM RKM 57.....H74	RKV FKFDV 49x-*M.....H96
RKCV FSFDV 48x-*M.....H144	RKM RKM 57-0.....H70	RKV FSFDV 48x-*M.....H144
RKCV FSFDV 49x-*M.....H96	RKM RKM 57-0/VM.....H68	RKV FSFDV 49x-*M.....H96
RKCV RKC 48x-*M.....H144	RKM RKM 57x-*M.....H49	RKV RKC 48x-*M.....H144
RKCV RKC 49x-*M.....H96	RKM RSC 25x-*M.....H167	RKV RKC 49x-*M.....H96
RKCV RKFPV 48x-*M.....H144	RKM RSC 57x-*M.....H49	RKV RKFPV 48x-*M.....H144
RKCV RKFPV 49x-*M.....H96	RKM RSFP 25x-*M.....H168	RKV RKFPV 49x-*M.....H96
RKCV RSFPV 48x-*M.....H144	RKM RSFP 57x-*M.....H50	RKV RKV 48.....H153
RKCV RSFPV 49x-*M.....H96	RKM WKC 25x-*M.....H168	RKV RKV 48x-*M.....H143
RKCV WKC 48x-*M.....H144	RKM WKC 57x-*M.....H50	RKV RKV 49.....H103
RKCV WKC 49x-*M.....H96	RKM WKM 25x-*M.....H167	RKV RKV 49x-*M.....H95
RKE 57-TR2.....H62	RKM WKM 57x-*M.....H49	RKV RSCV 48x-*M.....H143
RKF 25-*M.....H175	RKM WSC 25x-*M.....H168	RKV RSCV 49x-*M.....H95
RKF 25-*M/14.5.....H174	RKM WSC 57x-*M.....H50	RKV RSFPV 48x-*M.....H144
RKF 25-*M/14.75.....H174	RKS 84x-*M.....H13	RKV RSFPV 49x-*M.....H96
RKF 25-*M/M20.....H174	RKS FKSD 84-*M.....H13	RKV WKC 48x-*M.....H144
RKF 57.....H80	RKS RJ45S 84x-*M.....H14	RKV WKC 49x-*M.....H96
RKF 57-*M.....H77	RKS RJ45SMIP67 84x-*M.....H14	RKV WKV 48x-*M.....H143
RKF 57-*M/14.5.....H76	RKS RKS 84x-*M.....H13	RKV WKV 49x-*M.....H95
RKF 57-*M/14.75.....H76	RKS WRJ45ES 84x-*M.....H14	RKV WSCV 48x-*M.....H144

# DISTRIBUTED I/O SALES GUIDE



RKV WSCV 49x-*M.....H96	RSCD WSCD 44x-*M.....H21	RSM 25-FK 4.5.....H180
RPC49-10120EX.....H123	RSCS 2RKCS 48.....H152	RSM 25x-*M.....H167
RPC49-10265EX.....H123	RSCV 2RKCV 25.....H171	RSM 2RKM 57 DGT.....H71
RSA RSA 57x-*M.....H51	RSCV 2RKCV 49.....H102	RSM 2RKM 57-KF.....H67
RSC 25x-*M.....H167	RSCV 48x-*M.....H143	RSM 2RKM 57-KM.....H67
RSC 2RKC 57.....H73	RSCV 49x-*M.....H95	RSM 48-FK 4.4.....H153
RSC 2RKC 57/KS.....H73	RSCV FKFDV 48x-*M.....H144	RSM 49-FK 4.4.....H109
RSC 57x-*M.....H49,	RSCV FKFDV 49x-*M.....H96	RSM 57-FK 4.5.....H75
RSC 84x-*M.....H11	RSCV FSFDV 48x-*M.....H144	RSM 57-TR2.....H62
RSC 8VBRK RKC 5724-DCL.....H86	RSCV FSFDV 49x-*M.....H96	RSM 57-TR2/VM.....H62
RSC BK52C 57x-*M.....H53	RSCV RKCVC 48x-*M.....H144	RSM 57x-*M.....H49
RSC CBC5 57x-*M.....H53	RSCV RKCVC 49.....H102	RSM BK52C 57x-*M.....H53
RSC FKFD 25x-*M.....H168	RSCV RKCVC 49x-*M.....H96	RSM CBC5 57x-*M.....H53
RSC FKFD 57x-*M.....H52	RSCV RKFVPV 48x-*M.....H144	RSM FKFD 25x-*M.....H168
RSC FKFD 84x-*M.....H11	RSCV RKFVPV 49x-*M.....H96	RSM FKFD 57x-*M.....H50
RSC FSFD 25x-*M.....H168	RSCV RSCV 48x-*M.....H143	RSM FKM RKM 57.....H72
RSC FSFD 57x-*M.....H52	RSCV RSCV 49x-*M.....H95	RSM FSFD 25x-*M.....H168
RSC FSFD 84x-*M.....H11	RSCV RSFPV 48x-*M.....H144	RSM FSFD 57x-*M.....H50
RSC RJ45 84x-*M.....H12	RSCV RSFPV 49x-*M.....H96	RSM RKC 25x-*M.....H168
RSC RJ45IP67 84x.....H12	RSCV WKCVC 25.....H171	RSM RKC 57x-*M.....H50
RSC RJ45MIP67 84x-*M.....H12	RSCV WKCVC 48x-*M.....H144	RSM RKC 57x-*M RKM 57.....H72
RSC RKC 25.....H171	RSCV WKCVC 49.....H102	RSM RKFP 25x-*M.....H168
RSC RKC 25x-*M.....H168	RSCV WKCVC 49x-*M.....H96	RSM RKFP 57x-*M.....H50
RSC RKC 57.....H75	RSCV WSCV 48x-*M.....H144	RSM RKM 25x-*M.....H167
RSC RKC 572-*M/RKC 57.....H73	RSCV WSCV 49x-*M.....H96	RSM RKM 57 WSM 40 PST.....H71
RSC RKC 57x-*M.....H51	RSE 57-TR2.....H62	RSM RKM 57-0/VM.....H68
RSC RKC 84x-*M.....H11	RSEV 48-TR.....H151	RSM RKM 57x-*M.....H49
RSC RKFP 25x-*M.....H168	RSEV 49-TR.....H100	RSM RSC 25x-*M.....H167
RSC RKFP 57x-*M.....H52	RSF 25-*M.....H175	RSM RSC 57x-*M.....H49
RSC RSC 25x-*M.....H167	RSF 25-*M/14.5.....H174	RSM RSFP 25x-*M.....H168
RSC RSC 57x-*M.....H51	RSF 25-*M/14.75.....H174	RSM RSFP 57x-*M.....H50
RSC RSC 84x-*M.....H11	RSF 25-*M/M20.....H174	RSM RSM 25.....H172
RSC RSFP 25x-*M.....H168	RSF 57.....H80	RSM RSM 25x-*M.....H167
RSC RSFP 57x-*M.....H52	RSF 57-*M.....H77	RSM RSM 57.....H74
RSC WKC 25x-*M.....H168	RSF 57-*M/14.5.....H76	RSM RSM 57-0.....H70
RSC WKC 57.....H75	RSF 57-*M/14.75.....H76	RSM RSM 57-0/VM.....H68
RSC WKC 57x-*M.....H51	RSF 57-*M/M20.....H76	RSM RSM 57x-*M.....H49
RSC WKC 84x-*M.....H11	RSF 57-PCB.....H80	RSM WKC 25x-*M.....H168
RSC WRJ45E 84x-*M.....H12	RSF RKF 57/22.....H64	RSM WKC 57x-*M.....H50
RSC WSC 25x-*M.....H168	RSFP 25x-*M.....H168	RSM WKM 25x-*M.....H167
RSC WSC 57x-*M.....H51	RSFP 57x-*M.....H50	RSM WKM 57x-*M.....H49
RSC WSC 84x-*M.....H11	RSFP BK52C 57x-*M.....H54	RSM WSC 25x-*M.....H168
RSCD 44x-*M.....H21	RSFP CBC5 57x-*M.....H54	RSM WSC 57x-*M.....H50
RSCD FKFD 44x-*M.....H21	RSFPV 48x-*M.....H144	RSM WSM 25x-*M.....H167
RSCD FSFD 44x-*M.....H21	RSFPV 49x-*M.....H96	RSM WSM 57x-*M.....H49
RSCD RJ45 44x-*M.....H22	RSFV 49-*M.....H106	RSM-2RKM 57.....H67
RSCD RJ45IP67 44x-*M.....H22	RSFV 49-*M/14.5.....H105	RSS 84x-*M.....H13
RSCD RJ45MIP67 44x-*M.....H22	RSFV 49-*M/14.75.....H105	RSS FKSDE 84x-*M.....H13
RSCD RKCD 44x-*M.....H21	RSFV 49-*M/M20.....H105	RSS FSSDE 84x-*M.....H13
RSCD RSCD 44x-*M.....H21	RSFV RKFV 48/22.....H151	RSS RJ45S 84x-*M.....H14
RSCD WKCD 44x-*M.....H21	RSFV RKFV 49/22.....H101	RSS RJ45MIP67 84x-*M.....H14
RSCD WRJ45E 44x-*M.....H22	RSFV 49x-*M.....H99	RSS RKS 84x-*M.....H13

# INDEX

RSS RSS 84x-*M.....	H13	RSV RKCVC 49x-*M.....	H96	SPTSM13-A25.....	G10
RSS WKS 84x-*M.....	H13	RSV RKFPV 48x-*M.....	H144	SPTT1.....	G10
RSS WRJ45ES 84x-*M.....	H14	RSV RKFPV 49x-*M.....	H96	SPTT1-A25.....	G10
RSS WSS 84x-*M.....	H13	RSV RKV 48 SS.....	H154	SPTT1-A48.....	G10
RSSD 42x-*M.....	H37	RSV RKV 48x-*M.....	H143	SPTT1-A49.....	G10
RSSD 44x-*M.....	H23	RSV RKV 49 SS.....	H104	TB-M18-H1147.....	F10
RSSD FKSDED 42x-*M.....	H37	RSV RKV 49x-*M.....	H95	TB-M30-H1147.....	F10
RSSD FKSDED 44x-*M.....	H23	RSV RSCV 48x-*M.....	H143	TN902-Q175L200-H1147.....	F13
RSSD FSSDED 42x-*M.....	H37	RSV RSCV 49x-*M.....	H95	TN902-Q240L280-H1147.....	F13
RSSD FSSDED 44x-*M.....	H23	RSV RSFPV 48x-*M.....	H144	TN-CK40-H1147.....	F11
RSSD RJ45S 42x-*M.....	H38	RSV RSFPV 49x-*M.....	H96	TNLR-Q350-H1147.....	F12
RSSD RJ45S 44x-*M.....	H24	RSV RSV 48.....	H153	TNLR-Q80L400-H1147.....	F12
RSSD RJ45SMIP67 42x-*M.....	H38	RSV RSV 48x-*M.....	H143	TNLR-Q80L400-H1147L.....	F12
RSSD RJ45SMIP67 44x-*M.....	H24	RSV RSV 49.....	H103	TN-M18-H1147.....	F10
RSSD RKSD 42x-*M.....	H37	RSV RSV 49x-*M.....	H95	TN-M30-H1147.....	F10
RSSD RKSD 44x-*M.....	H23	RSV WKCV 48x-*M.....	H144	TN-Q14-0.15M-RS4.47T.....	F10
RSSD RSSD 42x-*M.....	H37	RSV WKCV 49x-*M.....	H96	TN-Q80-H1147.....	F11
RSSD RSSD 44x-*M.....	H23	RSV WKV 48x-*M.....	H143	TN-S32XL-H1147.....	F11
RSSD WKSD 44x-*M.....	H23	RSV WKV 49x-*M.....	H95	TNSLR-Q350-H1147.....	F12
RSSD WRJ45ES 42x-*M.....	H38	RSV WSCV 48x-*M.....	H144	TNSLR-Q42TWD-H1147.....	F11
RSSD WRJ45ES 44x-*M.....	H24	RSV WSCV 49x-*M.....	H96	TW860-960-L*.....	F9
RSSD WSSD 44x-*M.....	H23	RSV WSV 48x-*M.....	H143	TW860-960-L97-15-F-B28.....	F9
RSSW 45-TR.....	H134	RSV WSV 49x-*M.....	H95	TW860-960-Q25L77-B-B112.....	F9
RSSW 45x-*M.....	H128	RSV-2RKV 25.....	H171	TW860-960-Q27L97-M-B112.....	F9
RSSW D9S RKSX 45x-*M-*M.....	H131	RSV-2RKV 49.....	H102	TW860-960-Q51-HT-B110.....	F8
RSSW D9S RSSW 45x-*M-*M.....	H131	SD9S 45x-*M.....	H131	TW865-928-L76-18-21-F-M-B110.....	F9
RSSW D9S/T 45x-*M.....	H130	SD9S/T 45x-*M.....	H130	TW902-928-Q14L60-M-B110.....	F9
RSSW D9SM RKSX 45x-*M-*M.....	H131	SE20-84MT-RJ822.....	H33	TW902-928-Q27-M-B112.....	F9
RSSW D9SM RSSW 45x-*M.....	H131	SE20-84X-RJ522.....	H33	TW902-928-R50-B110.....	F8
RSSW D9SM/T 45x-*M.....	H130	SE20-84XT-RJ422-F0.....	H33	TW-BD10x1.5-19-B128.....	F7
RSSW RKSX 45x-*M.....	H128	SE20-84XT-RJ822.....	H33	TW-BD10x1.5-19-K2.....	F7
RSSW RSSW 45x-*M.....	H128	SE-44M-E924.....	H32	TW-BP12x1-S-B128.....	F7
RSSW SD9S RKSX 45x-*M-*M.....	H131	SE-44X4-E524.....	H32	TW-BS10x1.5-19-B128.....	F7
RSSW SD9S RSSW 45x-*M-*M.....	H131	SE-44X4-E924.....	H32	TW-BS10x1.5-19-K2.....	F7
RSSW SD9S/T 45x-*M.....	H130	SE-44X-E524.....	H32	TW-BS8X1.25-19-K2.....	F7
RSSW WKSX 45x-*M.....	H128	SE-44X-E924.....	H32	TW-BV10x1.5-19-B128.....	F7
RSSW WSSW 45x-*M.....	H128	SE-84ST-E524/C1165.....	H32	TW-BV10x1.5-19-K2.....	F7
RST 57x*.....	H58	SE-84ST-E924/C1165.....	H32	TW-C74-34-B256.....	F6
RST 57x-*.....	H59	SE-84X4-E524.....	H32	TW-C85-54-B256.....	F6
RSV 2RKV 48.....	H152	SE-84X4-E924.....	H32	TW-L36-18-S-B128.....	F7
RSV 48-TR.....	H151	SE-84X-E514/C1157.....	H32	TW-L43-43-S-B128.....	F7
RSV 48x-*M.....	H143	SE-84X-E524.....	H32	TW-R16-B128.....	F5
RSV 49-TR.....	H100	SE-84X-E914/C1157.....	H32	TW-R16-K2.....	F5
RSV 49x-*M.....	H95	SE-84X-E924.....	H32	TW-R20-B128.....	F5
RSV FKFDV 48x-*M.....	H144	SH-RKM/RSM/RKM 57.....	H70	TW-R20-K2.....	F5
RSV FKFDV 49x-*M.....	H96	SH-RKM/RSM/RKM 57/VM.....	H68	TW-R30-B128.....	F5
RSV FKV RKV 25.....	H171	SH-RSM-2RKM 57.....	H70	TW-R30-K2.....	F5
RSV FKV RKV 48.....	H152	SPTC2/C1243.....	G10	TW-R4-22-B128.....	F5
RSV FKV RKV 49.....	H102	SPTM1-A48.....	G10	TW-R50-MG25-B128.....	F8
RSV FSFDV 48x-*M.....	H144	SPTM1-A49.....	G10	TW-R7.5-B128.....	F5
RSV FSFDV 49x-*M.....	H96	SPTM1-A48.....	G10	TW-SPP18x1-B128.....	F7
RSV RKCVC 48x-*M.....	H144	SPTM1-A49.....	G10	TW-WB202-15-B128.....	F8

# DISTRIBUTED I/O SALES GUIDE



TW-WB202-15-B128.....F8	WKM 57x-*M.....H49	WKV RKCV 49x-*M.....H96
VB2/FSW/FKW/FSW 45.....H138	WKM BK52C 57x-*M.....H53	WKV RKFPV 48x-*M.....H144
VB2-FKM/FKM/FSM 57.....H65	WKM CBC5 57x-*M.....H53	WKV RKFPV 49x-*M.....H96
VB2-FKM/RKC RSC 57x-*M/*M.....H65	WKM FKFD 25x-*M.....H168	WKV RSCV 48x-*M.....H143
VB2-RKC 57x-*M-FKM FSM.....H65	WKM FKFD 57x-*M.....H50	WKV RSCV 49x-*M.....H95
WFS 57-PCB.....H82	WKM FSFD 25x-*M.....H168	WKV RSFPV 48x-*M.....H144
WFS 84-PCB.....H19	WKM FSFD 57x-*M.....H50	WKV RSFPV 49x-*M.....H96
WFSW 45 PCB.....H135	WKM RKC 25x-*M.....H168	WKV WKCV 48x-*M.....H144
WKC 25x-*M.....H168	WKM RKC 57x-*M.....H50	WKV WKCV 49x-*M.....H96
WKC 57x-*M.....H50	WKM RKFP 25x-*M.....H168	WKV WKV 48x-*M.....H143
WKC 84x-*M.....H11	WKM RKFP 57x-*M.....H50	WKV WKV 49x-*M.....H95
WKC BK52C 57x-*M.....H54	WKM RSC 25x-*M.....H167	WKV WSCV 48x-*M.....H144
WKC CBC5 57x-*M.....H54	WKM RSC 57x-*M.....H49	WKV WSCV 49x-*M.....H96
WKC FKFD 25x-*M.....H168	WKM RSFP 25x-*M.....H168	WRJ45 FKSDE 84x-*M.....H13
WKC FKFD 57x-*M.....H52	WKM RSFP 57x-*M.....H50	WRJ45 FSSDE 84x-*M.....H13
WKC FKFD 84x-*M.....H11	WKM WKC 25x-*M.....H168	WRJ45 RJ45MIP67 84x.....H12
WKC FSFD 25x-*M.....H168	WKM WKC 57x-*M.....H50	WRJ45E 44x-*M.....H22
WKC FSFD 57x-*M.....H52	WKM WKM 25x-*M.....H167	WRJ45E 84x-*M.....H12
WKC FSFD 84x-*M.....H11	WKM WKM 57x-*M.....H49	WRJ45E FKFD 84x-*M.....H11
WKC RJ45 84x-*M.....H12	WKM WSC 25x-*M.....H168	WRJ45E FKFD 44x-*M.....H21
WKC RJ45IP67 84x-*M.....H12	WKM WSC 57x-*M.....H50	WRJ45E FSFD 84x-*M.....H11
WKC RJ45MIP67 84x-*M.....H12	WKS 84x-*M.....H13	WRJ45E FSFDD 44x-*M.....H21
WKC RKFP 25x-*M.....H168	WKS FKSDE 84x-*M.....H13	WRJ45E RJ45 44x-*M.....H22
WKC RKFP 57x-*M.....H52	WKS FSSDE 84x-*M.....H13	WRJ45E RJ45 84x-*M.....H12
WKC RSFP 25x-*M.....H168	WKS RJ45S 84x-*M.....H14	WRJ45E RJ45IP67 44x-*M.....H22
WKC RSFP 57x-*M.....H52	WKS RJ45SMIP67 84x-*M.....H14	WRJ45E RJ45IP67 84x.....H12
WKC WKC 25x-*M.....H168	WKS RKS 84x-*M.....H13	WRJ45E RJ45MIP67 44x-*M.....H22
WKC WKC 57x-*M.....H51	WKS WKS 84x-*M.....H13	WRJ45E WRJ45E 44x-*M.....H22
WKC WKC 84x-*M.....H11	WKS WRJ45ES 84x-*M.....H14	WRJ45E WRJ4ES 84x-*M.....H12
WKC WRJ45E 84x-*M.....H12	WKSD 44x-*M.....H23	WRJ45ES 42x-*M.....H38
WKCD 44x-*M.....H21	WKSD FSSDED 44x-*M.....H23	WRJ45ES 44x-*M.....H24
WKCD FKFD 44x-*M.....H21	WKSD RJ45S 44x-*M.....H24	WRJ45ES 84x-*M.....H14
WKCD FSFDD 44x-*M.....H21	WKSD RJ45SMIP67 44x-*M.....H24	WRJ45ES FKSDED 42x-*M.....H37
WKCD RJ45 44x-*M.....H22	WKSD WKSD 44x-*M.....H23	WRJ45ES FKSDED 44x-*M.....H23
WKCD RJ45IP67 44x-*M.....H22	WKSD WRJ45ES 44x-*M.....H24	WRJ45ES FSSDED 42x-*M.....H37
WKCD RJ45MIP67 44x-*M.....H22	WKSD WSSD 44x-*M.....H23	WRJ45ES FSSDED 44x-*M.....H23
WKCD RKCD 44x-*M.....H21	WKSX 45x-*M.....H128	WRJ45ES RJ45S 42x-*M.....H38
WKCD WKCD 44x-*M.....H21	WKSX D9S WKSX 45x-*M-*M.....H131	WRJ45ES RJ45S 44x-*M.....H24
WKCD WRJ45E 44x-*M.....H22	WKSX D9S/T 45x-*M.....H130	WRJ45ES RJ45S 84x-*M.....H14
WKCV 48x-*M.....H144	WKSX D9SM WKSX 45x-*M-*M.....H131	WRJ45ES RJ45SMIP67 42x-*M.....H38
WKCV 49x-*M.....H96	WKSX D9SM/T 45x-*M.....H130	WRJ45ES RJ45SMIP67 44x-*M.....H24
WKCV FKFDV 48x-*M.....H144	WKSX SD9S WKSX 45x-*M-*M.....H131	WRJ45ES RJ45SMIP67 84x-*M.....H14
WKCV FKFDV 49x-*M.....H96	WKSX SD9S/T 45x-*M.....H130	WRJ45ES WRJ45ES 42x-*M.....H38
WKCV FSFDV 48x-*M.....H144	WKSX WKSX 45x-*M.....H128	WRJ45ES WRJ45ES 44x-*M.....H24
WKCV FSFDV 49x-*M.....H96	WKT 57x-*.....H58,	WRJ45ES WRJ45ES 84x-*M.....H14
WKCV RKFPV 48x-*M.....H144	WKV 48x-*M.....H143	WSC 25x-*M.....H168
WKCV RKFPV 49x-*M.....H96	WKV 49x-*M.....H95	WSC 2YBWK WKC 5724-1.5m-0.2m-0.2mH85
WKCV RSFPV 48x-*M.....H144	WKV FKFDV 48x-*M.....H144	WSC 57x-*M.....H50
WKCV RSFPV 49x-*M.....H96	WKV FKFDV 49x-*M.....H96	WSC 84x-*M.....H11
WKCV WKCV 48x-*M.....H144	WKV FSFDV 48x-*M.....H144	WSC BK52C 57x-*M.....H54
WKCV WKCV 49x-*M.....H96	WKV FSFDV 49x-*M.....H96	WSC CBC5 57x-*M.....H54
WKM 25x-*M.....H167	WKV RKCV 48x-*M.....H144	WSC FKFD 25x-*M.....H168

# INDEX

WSC FKFD 57x-*M.....H52	WSM BK52C 57x-*M.....H53	WSSW SD9S WKSX 45x-*M-*M.....H131
WSC FKFD 84x-*M.....H11	WSM CBC5 57x-*M.....H53	WSSW SD9S WSSW 45x-*M-*M.....H131
WSC FSFD 25x-*M.....H168	WSM FKFD 25x-*M.....H168	WSSW SD9S/T 45x-*M.....H130
WSC FSFD 57x-*M.....H52	WSM FKFD 57x-*M.....H50	WSSW WKSX 45x-*M.....H128
WSC FSFD 84x-*M.....H11	WSM FSFD 25x-*M.....H168	WSSW WSSW 45x-*M.....H128
WSC RJ45 84x-*M.....H12	WSM FSFD 57x-*M.....H50	WST 57x.....H58
WSC RJ45IP67 84x-*M.....H12	WSM RKC 25x-*M.....H168	WST 57x-*.....H59
WSC RJ45MIP67 84x-*M.....H12	WSM RKC 57x-*M.....H50	WSV 48x-*M.....H143
WSC RKC 25x-*M.....H168	WSM RKFP 25x-*M.....H168	WSV 49x-*M.....H95
WSC RKC 57x-*M.....H51	WSM RKFP 57x-*M.....H50	WSV FKFDV 48x-*M.....H144
WSC RKC 84x-*M.....H11	WSM RKM 25.....H172	WSV FKFDV 49x-*M.....H96
WSC RKFP 25x-*M.....H168	WSM RKM 25x-*M.....H167	WSV FSFDV 48x-*M.....H144
WSC RKFP 57x-*M.....H52	WSM RKM 57.....H74	WSV FSFDV 49x-*M.....H96
WSC RSC 84x-*M.....H11	WSM RKM 57x-*M.....H49	WSV RKCX 48x-*M.....H144
WSC RSFP 25x-*M.....H168	WSM RSC 25x-*M.....H167	WSV RKCX 49x-*M.....H96
WSC RSFP 57x-*M.....H52	WSM RSC 57x-*M.....H49	WSV RKFPV 48x-*M.....H144
WSC WKC 25x-*M.....H168	WSM RSFP 25x-*M.....H168	WSV RKFPV 49x-*M.....H96
WSC WKC 57x-*M.....H51	WSM RSFP 57x-*M.....H50	WSV RKV 48.....H153
WSC WKC 84x-*M.....H11	WSM WKC 25x-*M.....H168	WSV RKV 48x-*M.....H143
WSC WRJ45E 84x-*M.....H12	WSM WKC 57x-*M.....H50	WSV RKV 49.....H103
WSC WSC 25x-*M.....H168	WSM WKM 25x-*M.....H167	WSV RKV 49x-*M.....H95
WSC WSC 57x-*M.....H51	WSM WKM 57x-*M.....H49	WSV RSCV 48x-*M.....H143
WSC WSC 84x-*M.....H11	WSM WSC 25x-*M.....H168	WSV RSCV 49x-*M.....H95
WSCD 44x-*M.....H21	WSM WSC 57x-*M.....H50	WSV RSFPV 48x-*M.....H144
WSCD FKFD 44x-*M.....H21	WSM WSM 25x-*M.....H167	WSV RSFPV 49x-*M.....H96
WSCD FSFD 44x-*M.....H21	WSM WSM 57x-*M.....H49	WSV WKCX 48x-*M.....H144
WSCD RJ45 44x-*M.....H22	WSS 84x-*M.....H13	WSV WKCX 49x-*M.....H96
WSCD RJ45IP67 44x-*M.....H22	WSS FKSDE 84x-*M.....H13	WSV WKV 48x-*M.....H143
WSCD RJ45MIP67 44x-*M.....H22	WSS FSSDE 84x-*M.....H13	WSV WKV 49x-*M.....H95
WSCD RKCD 44x-*M.....H21	WSS RJ45S 84x-*M.....H14	WSV WSCV 48x-*M.....H144
WSCD RSCD 44x-*M.....H21	WSS RJ45SMIP67 84x-*M.....H14	WSV WSCV 49x-*M.....H96
WSCD WKCD 44x-*M.....H21	WSS RKS 84x-*M.....H13	WSV WSV 48x-*M.....H143
WSCD WRJ45E 44x-*M.....H22	WSS RSS 84x-*M.....H13	WSV WSV 49x-*M.....H95
WSCD WSCD 44x-*M.....H21	WSS WKS 84x-*M.....H13	YBZ2-FKM/FKW/FSW 45.....H138
WSCV 48x-*M.....H144	WSS WSS 84x-*M.....H13	YBZ2-FSW/FKW/FSW 45.....H138
WSCV 49x-*M.....H96	WSSD 44x-*M.....H23	
WSCV FKFDV 48x-*M.....H144	WSSD FKSDED 44x-*M.....H23	
WSCV FKFDV 49x-*M.....H96	WSSD FSSDED 44x-*M.....H23	
WSCV FSFDV 48x-*M.....H144	WSSD RJ45S 44x-*M.....H24	
WSCV FSFDV 49x-*M.....H96	WSSD RJ45SMIP67 44x-*M.....H24	
WSCV RKCX 48x-*M.....H144	WSSD RKSD 44x-*M.....H23	
WSCV RKCX 49x-*M.....H96	WSSD RSSD 44x-*M.....H23	
WSCV RKFPV 48x-*M.....H144	WSSD WKSX 44x-*M.....H23	
WSCV RKFPV 49x-*M.....H96	WSSD WRJ45ES 44x-*M.....H24	
WSCV RSFPV 48x-*M.....H144	WSSW 45x-*M.....H128	
WSCV RSFPV 49x-*M.....H96	WSSW D9S WKSX45x-*M-*M.....H131	
WSCV WKCX 48x-*M.....H144	WSSW D9S WSSW 45x-*M-*M.....H131	
WSCV WKCX 49x-*M.....H96	WSSW D9S/T 45x-*M.....H130	
WSCV WSCV 48x-*M.....H144	WSSW D9SM WKSX45x-*M-*M.....H131	
WSCV WSCV 49x-*M.....H96	WSSW D9SM WSSW45x-*M-*M.....H131	
WSM 25x-*M.....H167	WSSW D9SM/T 45x-*M.....H130	
WSM 57x-*M.....H49	WSSW RKSX 45x-*M.....H128	