

ATV930D55N4

variable speed drive, ATV930, 55kW, 400/480V,
with braking unit, IP21

Product availability : Non-Stock - Not normally stocked in distribution facility



Price** : 7,973.00 USD



Main

Range of product	Altivar Process ATV900
Product or component type	Variable speed drive
Device application	Industrial application
Device short name	ATV930
Variant	Standard version With braking chopper
Product destination	Asynchronous motors Synchronous motors
Mounting mode	Wall mount
EMC filter	Integrated conforming to EN/IEC 61800-3 category C3 with <= 150 m motor cable maxi
IP degree of protection	IP21 conforming to IEC 61800-5-1
Degree of protection	UL type 1 conforming to UL 508C
Type of cooling	Forced convection
Supply frequency	50...60 Hz (+/- 5 %)
Network number of phases	3 phases
[Us] rated supply voltage	380...480 V (- 15...10 %)
Motor power kW	55 kW (normal duty)
Motor power hp	75 hp (normal duty)
Line current	97.2 A at 380 V (normal duty)
Prospective line I _{sc}	50 kA
Apparent power	70 kVA at 480 V (normal duty)
Continuous output current	106 A at 2.5 kHz (normal duty)
Maximum transient current	127.2 A during 60 s (normal duty)
Asynchronous motor control profile	Constant torque standard Variable torque standard Optimized torque mode
Synchronous motor control profile	Permanent magnet motor Synchronous reluctance motor

Disclaimer: This documentation is not intended as a substitute for and is not to be used for determining suitability or reliability of these products for specific user applications

Speed drive output frequency	0.1...599 Hz
Nominal switching frequency	2.5 kHz
Switching frequency	1...8 kHz adjustable 2.5...8 kHz with derating factor
Safety function	STO (safe torque off) SIL 3
Number of preset speeds	16 preset speeds
Communication port protocol	Ethernet/IP Modbus serial Modbus TCP
Option module	Slot A: communication module Profibus DP V1 Slot A: communication module Profinet Slot A: communication module DeviceNet Slot A: communication module CANopen daisy chain RJ45 Slot A: communication module CANopen SUB-D 9 Slot A: communication module CANopen screw terminals Slot A: communication module EtherCAT Slot A/slot B/slot C: digital and analog I/O extension module Slot A/slot B/slot C: output relay extension module Slot B: 5/12 V digital encoder interface module Slot B: analog encoder interface module Slot B: resolver encoder interface module

Complementary

Output voltage	<= power supply voltage
Motor slip compensation	Adjustable Automatic whatever the load Can be suppressed Not available in permanent magnet motor law
Acceleration and deceleration ramps	Linear adjustable separately from 0.01...9999 s
Braking to standstill	By DC injection
Protection type	Motor: thermal protection Motor: safe torque off Motor: motor phase break Drive: thermal protection Drive: safe torque off Drive: overheating Drive: overcurrent between output phases and earth Drive: overload of output voltage Drive: short-circuit protection Drive: motor phase break Drive: overvoltages on the DC bus Drive: line supply overvoltage Drive: line supply undervoltage Drive: line supply phase loss Drive: overspeed Drive: break on the control circuit
Frequency resolution	Display unit: 0.1 Hz Analog input: 0.012/50 Hz
Electrical connection	Control, screw terminal: 0.5...1.5 mm ² (AWG 20...AWG 16)
Connector type	2 RJ45 (on the control block) Ethernet IP/Modbus TCP
Physical interface	2-wire RS 485 Modbus serial
Transmission frame	RTU Modbus serial
Transmission rate	10/100 Mbit/s Ethernet IP/Modbus TCP 4.8, 9.6, 19.2, 38.4 kbit/s for Modbus serial
Exchange mode	Half duplex, full duplex, autonegotiation Ethernet IP/Modbus TCP
Data format	8 bits, configurable odd, even or no parity Modbus serial
Type of polarization	No impedance Modbus serial
Number of addresses	For Modbus serial
Method of access	Slave Modbus TCP
Supply	External supply for digital inputs: 24 V DC (19...30 V) current <= 1.25 mA (overload and short-circuit protection)
Local signalling	3 mono/dual colour LED for local diagnostic
Width	11.42 in (290 mm)

Height	36.3 in (922 mm)
Depth	12.81 in (325.5 mm)
Product weight	126.77 lb(US) (57.5 kg)
Analogue input number	3
Analogue input type	Software-configurable voltage AI1, AI2, AI3: 0...10 V DC impedance 30 kOhm, resolution 12 bits
Discrete input number	10
Discrete input type	Programmable DI1...DI8: 24 V DC (<= 30 V) impedance 3.5 kOhm
Input compatibility	Discrete input DI1...DI8: level 1 PLC conforming to EN/IEC 61131-2
Analogue output number	2
Discrete output number	2
Discrete output type	Logic output DQ+ : 0...1 kHz (<= 30 V) DC, 100 mA
Sampling duration	Discrete input DI1...DI8: 2 ms (+/- 0.5 ms)
Accuracy	Analog input AI1, AI2, AI3: +/- 0.6 % for a temperature variation 60 °C Analog output AQ1, AQ2: +/- 1 % for a temperature variation 60 °C
Linearity error	Analog input AI1, AI2, AI3: +/- 0.15 % of maximum value
Maximum switching current	Relay output R1 on resistive load (cos phi = 1) : 3 A at 250 V AC
Relay output number	3
Relay output type	Configurable relay logic R1: fault relay NO/NC electrical durability 100000 cycles
Refresh time	Relay output R1, R2, R3: 5 ms (+/- 0.5 ms)
Minimum switching current	Relay output R1, R2, R3: 5 mA at 24 V DC
Isolation	Between power and control terminals
Specific application	Process
IP degree of protection	IP21
Motor starter type	Variable speed drive

Environment

Insulation resistance	> 1 mOhm at 500 V DC for 1 minute to earth
Noise level	68.3 dB conforming to 86/188/EEC
Power dissipation in W	131 W (natural convection) at 380 V switching frequency 2.5 kHz
Vibration resistance	1.5 mm peak to peak (f = 2...13 Hz) conforming to IEC 60068-2-6 1 gn (f = 13...200 Hz) conforming to IEC 60068-2-6
Shock resistance	15 gn during 11 ms conforming to IEC 60068-2-27
Volume of cooling air	77932.15 Gal/hr(US) (295 m3/h)
Operating position	Vertical +/- 10 degree
THDI	<= 48 % from 80...100 % of load conforming to IEC 61000-3-12
Electromagnetic compatibility	1.2/50 µs - 8/20 µs surge immunity test level 3 conforming to IEC 61000-4-5 Electrical fast transient/burst immunity test level 4 conforming to IEC 61000-4-4 Electrostatic discharge immunity test level 3 conforming to IEC 61000-4-2 Radiated radio-frequency electromagnetic field immunity test level 3 conforming to IEC 61000-4-3 Conducted radio-frequency immunity test level 3 conforming to IEC 61000-4-6
Pollution degree	2 EN/IEC 61800-5-1
Environmental characteristic	Chemical pollution resistance class 3C3 conforming to EN/IEC 60721-3-3 Dust pollution resistance class 3S3 conforming to EN/IEC 60721-3-3
Relative humidity	5...95 % without condensation conforming to IEC 60068-2-3
Ambient air temperature for operation	-15...50 °C without 122...140 °F (50...60 °C) with derating factor
Ambient air temperature for storage	-40...158 °F (-40...70 °C)
Operating altitude	1000...4800 m with current derating 1 % per 100 m
Standards	EN/IEC 61800-3 UL 508C EN/IEC 61800-5-1 IEC 61000-3-12 IEC 60721-3 IEC 61508 IEC 13849-1 EN/IEC 61800-3 (environment 1 category C2) EN/IEC 61800-3 (environment 2 category C3)

Product certifications	CSA TÜV UL REACH
Marking	CE

Ordering and shipping details

Category	22277 - ATV930 FRAMES 3 & 4
Discount Schedule	CP4E
GTIN	00785901472582
Nbr. of units in pkg.	1
Package weight(Lbs)	157
Returnability	Y
Country of origin	IN

Offer Sustainability

Sustainable offer status	Green Premium product
RoHS (date code: YYWW)	Compliant - since 1526 - Schneider Electric declaration of conformity Schneider Electric declaration of conformity
REACH	Reference not containing SVHC above the threshold Reference not containing SVHC above the threshold
Product environmental profile	Available Product Environmental Profile
Product end of life instructions	Available End of Life Information
California proposition 65	WARNING: This product can expose you to chemicals including:
----- Substance 1	Lead and lead compounds, which is known to the State of California to cause cancer and birth defects or other reproductive harm.
----- Substance 2	Bisphenol A (BPA), which is known to the State of California to cause birth defects or other reproductive harm.
----- More information	For more information go to www.p65warnings.ca.gov

Dimensions

IP21 / UL Type 1 Drives - Front and Left Side View

mm
in.

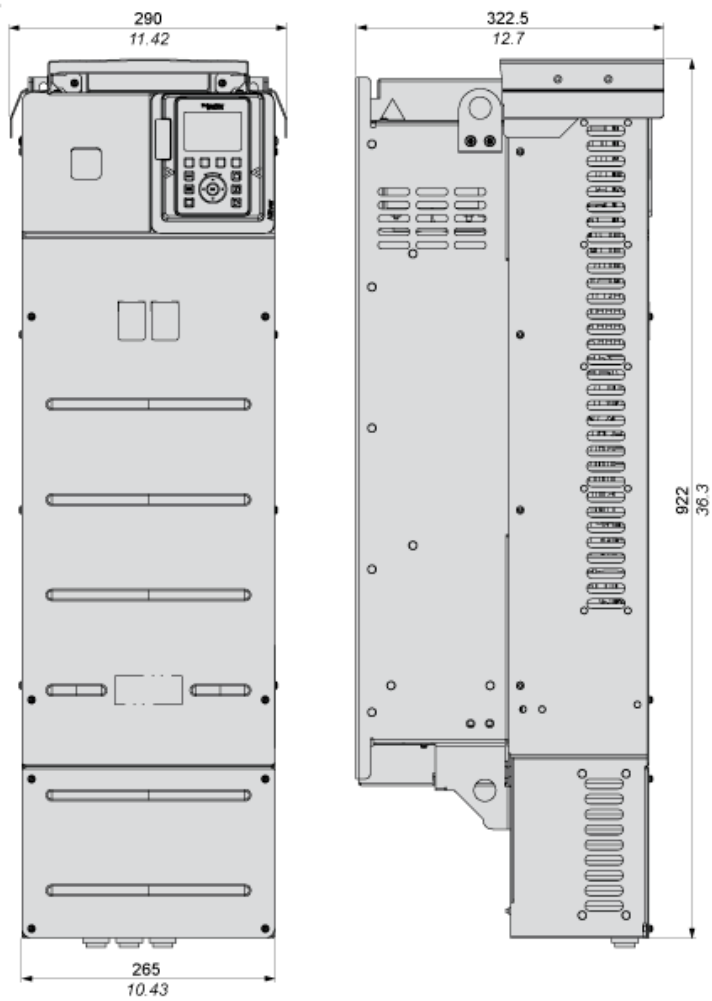

Drives without IP21 Top Cover - Rear View

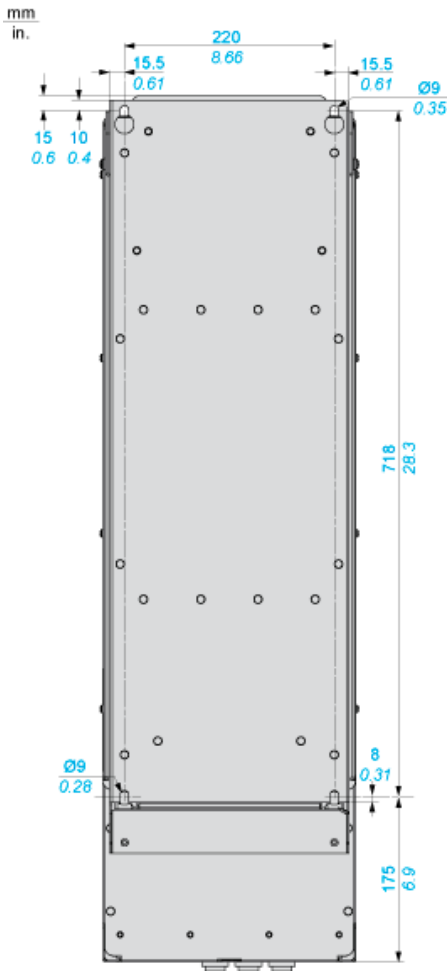

Clearances

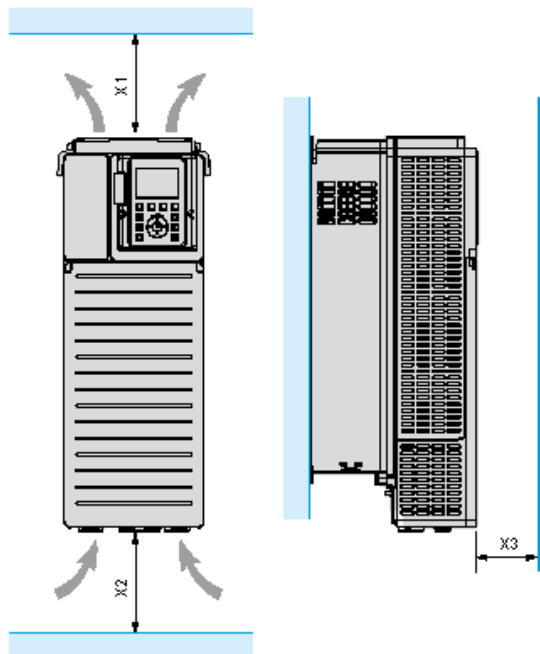

X1	X2	X3
≥ 100 mm (3.94 in.)	≥ 100 mm (3.94 in.)	≥ 10 mm (0.39 in.)

- Mount the device in a vertical position ($\pm 10^\circ$). This is required for cooling the device.
- Do not mount the device close to heat sources.
- Leave sufficient free space so that the air required for cooling purposes can circulate from the bottom to the top of the drive.

Mounting Types

Mounting Type A: Individual IP21

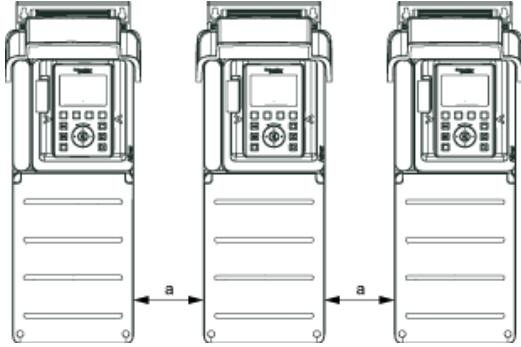

$a \geq 110 \text{ mm (4.33 in.)}$

Mounting Type B: Side by Side IP20 (Possible, 2 Drives Only)

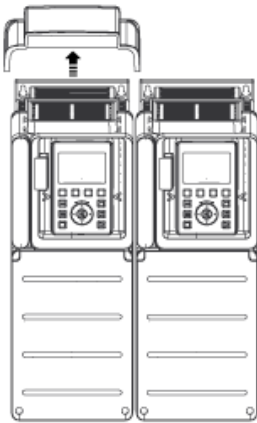

Mounting Type C: Individual IP20

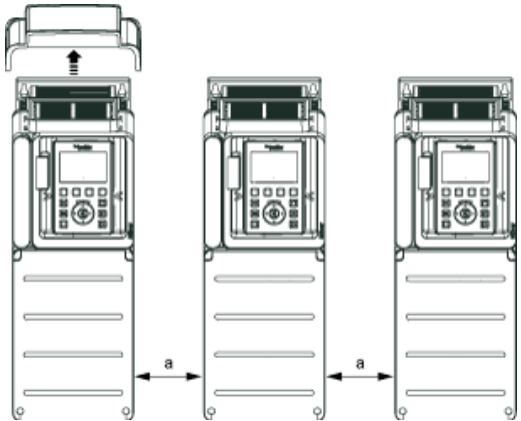

$a \geq 110 \text{ mm (4.33 in.)}$