



### Main

Range of product	Modicon Momentum automation platform
Product or component type	Discrete solid state I/O base DC
Group of channels	1 group of 16 inputs 2 groups of 8 outputs
Discrete input number	16 IEC 1131-2 Type 1
Discrete input logic	Positive
Discrete input voltage	24 V DC
Discrete output number	16
Discrete output type	Solid state switch
Discrete output voltage	$\leq 30$ V DC 24 V DC
Discrete output logic	Positive
Protective treatment	TC

### Complementary

[Us] rated supply voltage	24 V DC
Input voltage limits	- 3...30 V
Voltage state 0 guaranteed	-3...5 V
Voltage state 1 guaranteed	11...30 V
Current state 0 guaranteed	$\leq 1.2$ mA
Current state 1 guaranteed	$\geq 2.5$ mA
Input resistance	4 kOhm
Discrete output current	4 A per group 8 A per module 0.5 A per point
Leakage current	$< 1$ mA 24 V output circuit
Peak output current	5 A
Voltage drop	$< 0.5$ V 0.5 A at state 1 output circuit

Disclaimer: This documentation is not intended as a substitute for and is not to be used for determining suitability or reliability of these products for specific user applications

Fault type	Overload on output
Response time	< 0.1 ms from state 0 to state 1 on output < 0.1 ms from state 1 to state 0 on output 2.2 ms from state 0 to state 1 on input 3.3 ms from state 1 to state 0 on input
Isolation between channels and bus	500 V AC
Power dissipation	<= 8 W 6 W
Marking	CE
Terminals description PLC n°1	(1)IN_DIS#1 (10)IN_DIS#10 (11)IN_DIS#11 (12)IN_DIS#12 (13)IN_DIS#13 (14)IN_DIS#14 (15)IN_DIS#15 (16)IN_DIS#16 (2)IN_DIS#2 (3)IN_DIS#3 (4)IN_DIS#4 (5)IN_DIS#5 (6)IN_DIS#6 (7)IN_DIS#7 (8)IN_DIS#8 (9)IN_DIS#9 (L+)PW_POS (M-)PW_NEG TB
Terminals description PLC n°2	(1)OUT_DIS#1 (10)OUT_DIS#10 (11)OUT_DIS#11 (12)OUT_DIS#12 (13)OUT_DIS#13 (14)OUT_DIS#14 (15)OUT_DIS#15 (1L+)PW_POS (2)OUT_DIS#2 (2L+)PW_POS (3)OUT_DIS#3 (4)OUT_DIS#4 (5)OUT_DIS#5 (6)OUT_DIS#6 (7)OUT_DIS#7 (8)OUT_DIS#8 (9)OUT_DIS#9 TB_1
Local signalling	16 LEDs channel status
Current consumption	250 mA 24 V DC
Depth	47.5 mm
Height	141.5 mm
Width	125 mm
Product weight	0.2 kg

## Environment

Product certifications	CSA UL
Resistance to electrostatic discharge	4 kV contact IEC 801-2 8 kV on air IEC 801-2
Resistance to electromagnetic fields	10 V/m 80...1000 MHz IEC 801-3
Ambient air temperature for operation	0...60 °C
Ambient air temperature for storage	-40...85 °C
Relative humidity	95 % without condensation
Operating altitude	<= 5000 m

## Offer Sustainability

Sustainable offer status	Green Premium product
RoHS (date code: YYWW)	Compliant - since 0901 - Schneider Electric declaration of conformity <a href="#">Schneider Electric declaration of conformity</a>
REACH	Reference not containing SVHC above the threshold <a href="#">Reference not containing SVHC above the threshold</a>
Product environmental profile	Available <a href="#">Product Environmental Profile</a>
Product end of life instructions	Available <a href="#">End of Life Information</a>

## Contractual warranty

Warranty period	18 months
-----------------	-----------

Standard Adapter on a Typical Base

Dimensions

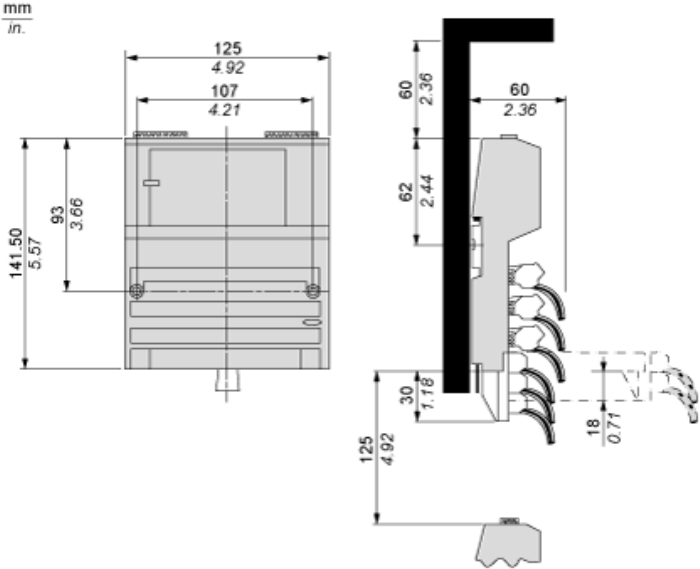

---

Mounting on a Wall

---

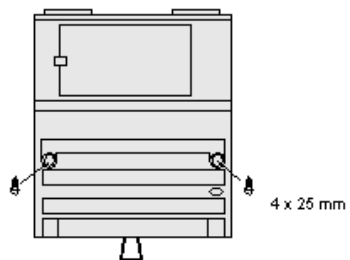

External Wiring Diagrams

2-Wire Devices

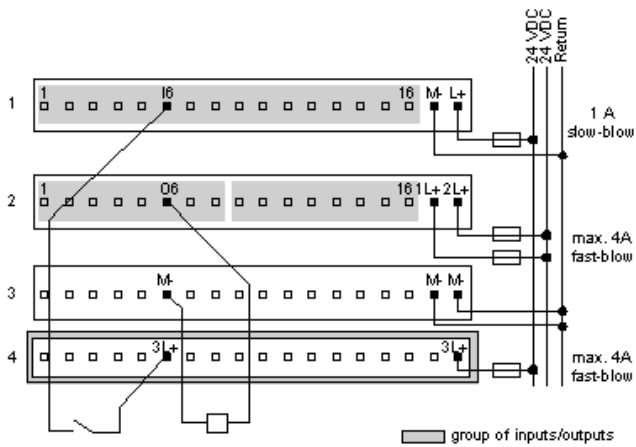

Sensor Activated by Output

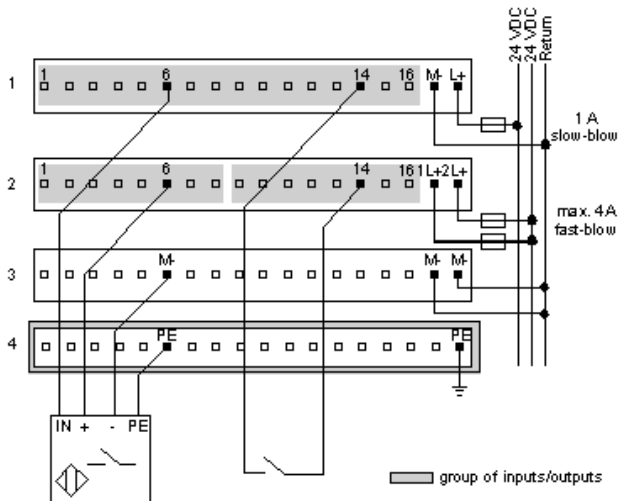

## Four-Wire Sensor with a Two-Wire Actuator

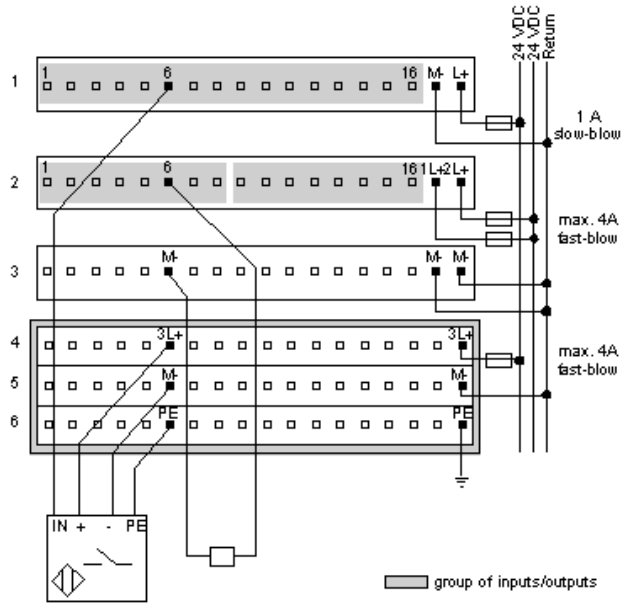

## Broken Wire Detection

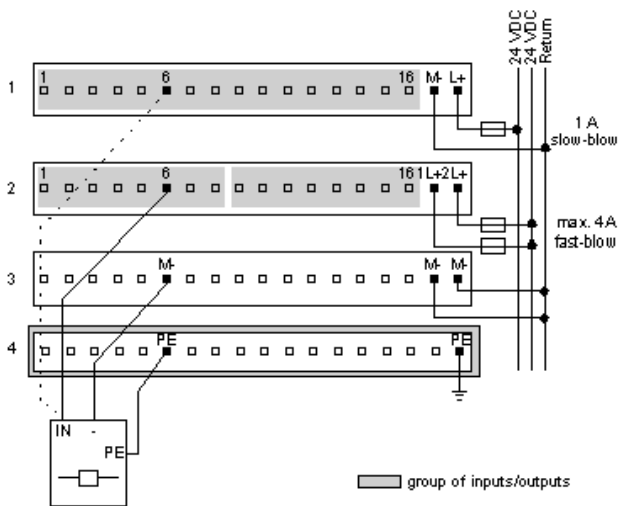

---

Internal Pin Connections

---

Rows 1 through 3 show the internal connections between terminals on the I/O base. Rows 4 through 6 show the internal connections on the optional busbar.

