



Main

| | |
|-------------------------------|---|
| Range of product | OsiSense XC |
| Series name | Standard format |
| Product or component type | Limit switch |
| Device short name | XCKJ |
| Sensor design | Form A conforming to CENELEC EN 50041 |
| Body type | Fixed |
| Head type | Rotary head |
| Material | Metal |
| Body material | Zamak |
| Head material | Zamak |
| Fixing mode | By the body |
| Movement of operating head | Rotary |
| Type of operator | Spring return roller lever metal |
| Type of approach | Lateral approach 1 or 2 programmable direction |
| Cable entry | 1 entry tapped for M20 x 1.5 cable gland, cable outer diameter: 7...13 mm |
| Number of poles | 2 |
| Contacts type and composition | 1 NC + 1 NO |
| Contact operation | Snap action |

Complementary

| | |
|---------------------------------|--|
| Switch actuation | By 30° cam |
| Electrical connection | Screw-clamp terminals, clamping capacity: 1 x 0.34...2 x 1.5 mm ² |
| Contacts insulation form | Zb |
| Number of steps | 1 |
| Positive opening | With |
| Positive opening minimum torque | 0.5 N.m |
| Minimum torque for tripping | 0.25 N.m |

| | |
|--|--|
| Maximum actuation speed | 1.5 m/s |
| [Ie] rated operational current | 3 A at 240 V, AC-15, A300 conforming to EN/IEC 60947-5-1 appendix A 0.27 A at 250 V, DC-13, Q300 conforming to EN/IEC 60947-5-1 appendix A |
| [Ithe] conventional enclosed thermal current | 10 A |
| [Ui] rated insulation voltage | 300 V conforming to CSA C22.2 No 14 500 V degree of pollution 3 conforming to IEC 60947-1 300 V conforming to UL 508 |
| Resistance across terminals | <= 25 MOhm conforming to IEC 60255-7 category 3 |
| [Uimp] rated impulse withstand voltage | 6 kV conforming to IEC 60664 6 kV conforming to IEC 60947-1 |
| Short-circuit protection | 10 A by gG cartridge fuse |
| Electrical durability | 5000000 cycles, DC-13, inductive load type, 24 V, 10 W, operating rate: <= 60 cyc/mn, load factor: 0.5 conforming to IEC 60947-5-1 appendix C 5000000 cycles, DC-13, inductive load type, 48 V, 7 W, operating rate: <= 60 cyc/mn, load factor: 0.5 conforming to IEC 60947-5-1 appendix C 5000000 cycles, DC-13, inductive load type, 120 V, 4 W, operating rate: <= 60 cyc/mn, load factor: 0.5 conforming to IEC 60947-5-1 appendix C |
| Mechanical durability | 30000000 cycles |
| Width | 40 mm |
| Height | 77 mm |
| Depth | 44 mm |
| Product weight | 0.49 kg |
| Terminals description ISO n°1 | (13-14)NO (21-22)NC |

Environment

| | |
|---------------------------------------|---|
| Shock resistance | 50 gn (duration = 11 ms) conforming to IEC 60068-2-27 |
| Vibration resistance | 25 gn (f = 10...500 Hz) conforming to IEC 60068-2-6 |
| IP degree of protection | IP66 conforming to IEC 60529 |
| IK degree of protection | IK07 conforming to EN 50102 |
| Overvoltage category | Class I conforming to NF C 20-030 Class I conforming to IEC 61140 |
| Ambient air temperature for operation | -25...70 °C |
| Ambient air temperature for storage | -40...70 °C |
| Protective treatment | TC |
| Product certifications | CCC CSA UL |
| Standards | CENELEC EN 50041 EN 60204-1 EN 60947-5-1 IEC 60204-1 IEC 60947-5-1 UL 508 CSA C22.2 No 14 |

Offer Sustainability

| | |
|----------------------------------|---|
| Sustainable offer status | Green Premium product |
| RoHS (date code: YYWW) | Compliant - since 0951 - Schneider Electric declaration of conformity  Schneider Electric declaration of conformity |
| REACH | Reference not containing SVHC above the threshold Reference not containing SVHC above the threshold |
| Product end of life instructions | Need no specific recycling operations |

Contractual warranty

| | |
|-----------------|-----------|
| Warranty period | 18 months |
|-----------------|-----------|

Dimensions

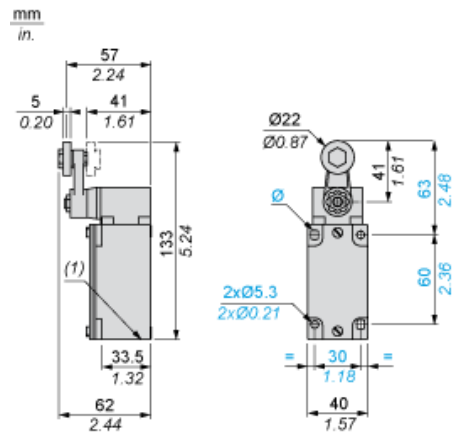

(1) 1 tapped entry M20 x 1.5

Mounting with Cable Entry

Position of Cable Gland



- (1) Recommended
- (2) To be avoided

Mounting with Rotary Heads and Levers

Type of Cam

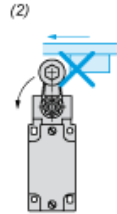
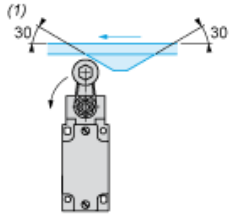

- (1) Recommended
- (2) To be avoided

Setting-up with Lever Head

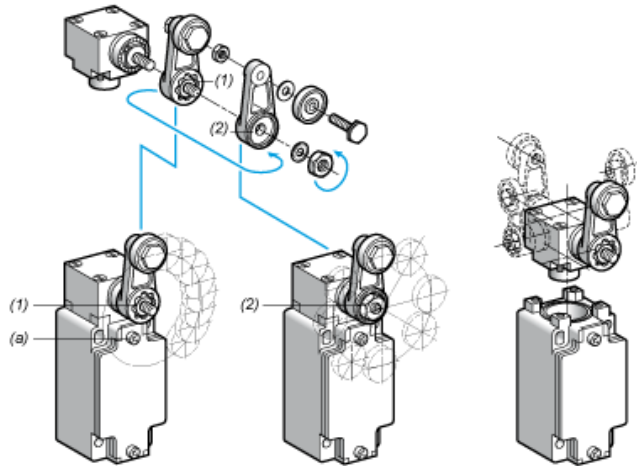

- (1) 5° steps throughout 360° / Tightening torque (Min : 1) (Max : 1.5)
- (2) 45° steps throughout 360° / Tightening torque (Min : 1) (Max : 1.5)
- (a) Tightening torque (Min : 1) (Max : 1.5)

Setting-up with Head ZCKE05

Direction of Actuation Programming

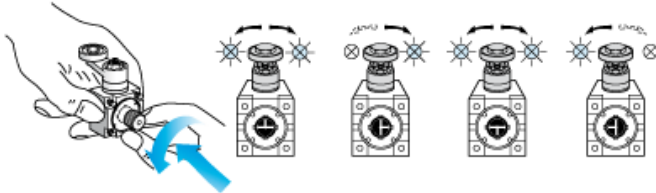

Wiring Diagram

2-pole NC + NO Snap Action

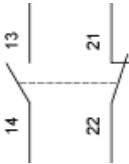

Characteristics of Actuation

Switch Actuation on End

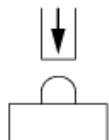

Functionnal Diagram

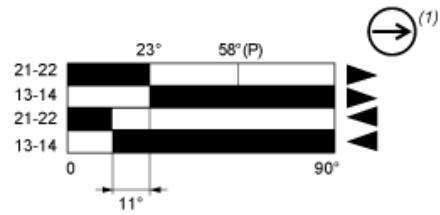

- (2)
- (3)
- ▲ (4)
- ▼ (5)

- (P) Positive opening point
- (1) NC contact with positive opening operation
- (2) Closed
- (3) Open
- (4) Tripping
- (5) Resetting