



Main

Range of product	Harmony XB6
Product or component type	Complete body for pilot lights
Device short name	ZB6
Sale per indivisible quantity	5
Connections - terminals	Pins for printed circuit board (1 x 0.5 mm)
Light source	LED
Bulb base	Integral LED
Light block supply	Direct
Light source colour	Green
[Us] rated supply voltage	12...24 V AC/DC

Complementary

Product weight	0.003 kg
Operating position	Any position
[Ui] rated insulation voltage	250 V (degree of pollution: 3) conforming to EN/IEC 60947-1
[Uimp] rated impulse withstand voltage	4 kV conforming to EN 60947-1
Signalling type	Steady
Supply voltage limits	6...30 V AC/DC
Current consumption	15 mA
Surge withstand	1 kV in contact conforming to IEC 61000-4-5 2 kV in free air conforming to IEC 61000-4-5

Environment

Protective treatment	TC
Ambient air temperature for storage	-40...70 °C
Ambient air temperature for operation	-25...70 °C
Electrical shock protection class	Class II conforming to IEC 61140
Standards	EN/IEC 60947-1 EN/IEC 60947-5-1 EN/IEC 60947-5-5 JIS C 4520 JIS C 852 UL 508

Product certifications	CCC CSA GOST UL
Vibration resistance	+/- 3 mm (f = 2...500 Hz) conforming to IEC 60068-2-6 5 gn (f = 2...500 Hz) conforming to IEC 60068-2-6
Shock resistance	30 gn (duration = 18 ms) for half sine wave acceleration conforming to IEC 60068-2-27 50 gn (duration = 11 ms) for half sine wave acceleration conforming to IEC 60068-2-27
Resistance to fast transients	2 kV conforming to IEC 61000-4-4
Resistance to electromagnetic fields	10 V/m conforming to IEC 61000-4-3
Resistance to electrostatic discharge	6 kV on contact (on metal parts) conforming to IEC 61000-2-6 8 kV in free air (in insulating parts) conforming to IEC 61000-2-6
Electromagnetic emission	Class B conforming to IEC 55011

Contractual warranty

Warranty period	18 months
-----------------	-----------

Body for Pilot Light

Dimensions

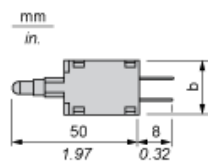

b 15.5 mm/0.61 in.

Pushbuttons, Switches and Pilot Lights for Printed Circuit Board Connection

Front Panel Cut-out (Viewed from Installer's Side)

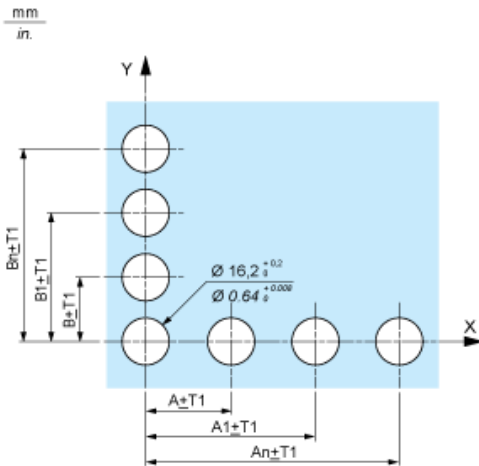

Printed Circuit Board Drillings (Viewed from Electrical Block Side)

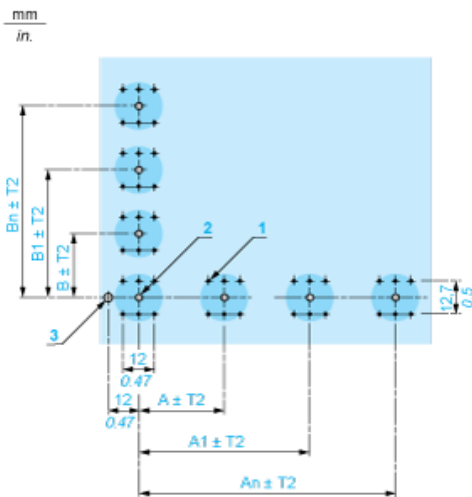

A 24 mm/0.94 in. minimum for rectangular heads, 18 mm/0.71 in. minimum for square or circular heads

B 18 mm/0.71 in. minimum

(1) 6 x Ø 1.1 mm / 6 x Ø 0.04 in. holes.

(2) 1 x Ø 2.6⁰_{-0.2} mm / 1 x Ø 0.10⁰_{-0.008} in. hole for locating pin, only when using socket adaptor ZB6Y010.

(3) 1 x Ø 3.2⁰_{-0.2} mm / 1 x Ø 0.13⁰_{-0.008} in. hole for fixing of printed circuit board onto the front panel using body bracket ZB6Y011. This hole must be drilled

General tolerances of the panel and printed circuit board: T1, T2: T1 + T2 = 0.3 mm/0.01 in. maximum.

Installation precautions:

Thickness of printed circuit board: 1.6 mm/0.06 in. minimum.

Mounting with Body Bracket

With socket adaptor ZB6Y010

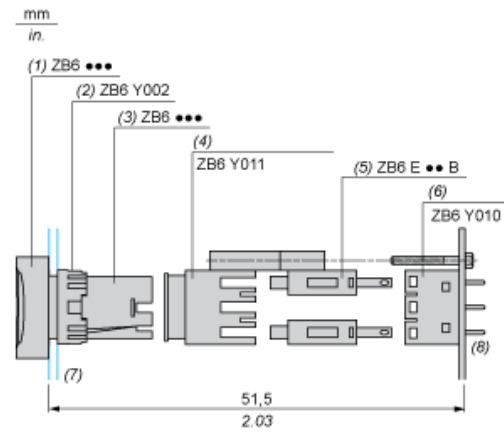

- (1) Head
- (2) Nut
- (3) Body
- (4) Body bracket
- (5) Contact block
- (6) Socket adaptor
- (7) Panel
- (8) Printed circuit

Direct mounting without socket adaptor ZB6Y010

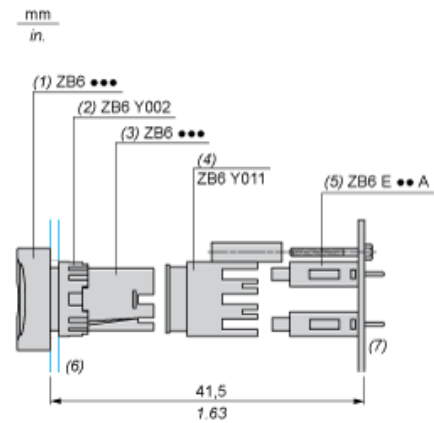

- (1) Head
- (2) Nut
- (3) Body
- (4) Body bracket
- (5) Contact block
- (6) Panel
- (7) Printed circuit