

Reels & Cameras



SeeSnake® microREEL VIDEO INSPECTION SYSTEM

1½" to 4 / 5" (40 to 100 / 125 mm)* lines up to 100' (30 m).

Passes 90° bends in most 2" (50 mm) lines.

microReel video inspection system provides small size and maneuverability for small diameter and tight-turn radius inspections.

* 4" (100 mm) when used with a microEXPLORER™ or micro CA-300 inspection cameras. 5" (125 mm) when used with a SeeSnake monitor.

- Lightweight and compact design is one-half the size of popular inspection systems, easily stowed in a truck and carried onto the jobsite.
- Multi-monitor compatibility with existing SeeSnake monitors, or the micro CA-300 digital inspection camera.
- Durable and reliable construction with hardened stainless steel camera head spring assembly for a long service life. Long-lasting high-intensity lights for exceptional viewing.
- Stiffer push cable than microDrain to enable line inspections up to 100' (30m).

SPECIFICATIONS

SeeSnake microREEL L100 & L100C SYSTEMS

- Camera Head – 0.98" (25 mm)
- Cable Length – 100' (30 m)
- Cable Diameter – 0.27" (6,7 mm)
- Line Capacity – 1½" to 4" or 5" (40 - 100 / 125 mm)
- Weight – 10.3 lbs. (4,7 kg)
- Size – Length 13.25" (33.7 cm), Width 6.6" (16.8 cm), Height 14.2" (36.1 cm)
- Resolution – 656 x 492
- Ball Guide – 2 included
- Sonde – 512 Hz
- Counter – Optional (L100C)



100' (30m) microReel L100 w/Sonde

| Catalog No. | Description | Weight | |
|-------------|---|--------|-----|
| | | lb. | kg |
| 35133 | microReel L100 (SS CCU) NTSC | 10.3 | 4.7 |
| 35143 | microReel L100 (CA300) NTSC | | |
| 40798 | microReel L100/micro CA-300 System NTSC | 11.6 | 5.3 |

100' (30m) microReel L100C w/Sonde and Counter

| Catalog No. | Description | Weight | |
|-------------|--|--------|-----|
| | | lb. | kg |
| 35183 | microReel L100C (SS CCU) Counter NTSC | 10 | 4.7 |
| 35188 | microReel L100C (CA300) Counter NTSC | | |
| 40808 | microReel L100C/micro CA-300 System NTSC | 12 | 5.3 |



Accessories

| Catalog No. | Description | Weight | |
|-------------|---|--------|------|
| | | lb. | kg |
| 33108 | Interconnect Cable for SeeSnake Monitor | 0.65 | 0.31 |
| 33113 | Interconnect Cable for CA-300 Monitor | | |
| 34623 | microReel L100 Drum Only w/Sonde NTSC | 5.5 | 2.5 |
| 35243 | microReel L100C Drum Only NTSC | | |
| 35338 | 45 mm Pipe Guide, Fits 25 mm Camera (pkg. of 2) | | |
| 40598 | 60 mm Pipe Guide, Fits 25 mm Camera (pkg. of 2) | | |

Standard Equipment

| Catalog No. Model No. | 40798 - |
|--|------------|
| Reel, Microreel L100 115V Exp | • |
| 37888 - micro CA-300 Inspection Camera | • |

(SeeSnake) = the reel containing the pushcable and camera head with a connection cable for a SeeSnake monitor.
(CA-300) = the reel containing the pushcable and camera head with a connection cable for a CA-300 monitor.

Reels & Cameras



SeeSnake® NANOREEL INDUSTRIAL VIDEO INSPECTION SYSTEM

¾" to 2" (20 to 50 mm) capacity up to 85' (25 m).

Passes 90° bends in most 1¾" (30 mm) lines.

The nanoReel system opens up new possibilities in long run small diameter inspection needs. Applications where only bore scopes could reach can now be inspected using the nanoReel system. Boiler tubes, supply lines, sprinkler systems, and a wide array of specialty applications can be inspected using the nanoReel system.

- Small diameter and tight turn radius camera allows lines up to 85' (25 m) to be inspected with tight turns in 1" (25 mm) lines.
- Lightweight and compact unit allows for easy transport and efficient storage.
- Interchangeable drums let you change out the inner drum depending on the application.
- L100/L100C – 1½" to 5" (40 - 125 mm) lines with a stiffer push cable allowing you to inspect lines up to 100' (30 m).
- D30 and D65S – Small diameter with tight turns, 1½" to 4" (40 - 100 mm) P-traps, toilet traps, pool lines up to 65' (20 m).
- N85S – Ultra small diameter lines ¾" to 2" (20 - 50 mm) with tight turns for specialized applications.

SPECIFICATIONS

- Camera Head – 0.62 (15.5 mm)
- Cable Length – 85' (25 m)
- Cable Diameter – 0.25 (6.3 mm)
- Line Capacity – ¾ to 2" (20 - 50 mm)
- Weight – 9.5 lbs. (4,1 kg)
- Size – Length 13.25" (33.7 cm), Width 6.6" (16.8 cm), Height 17.5" (44.5 cm)
- Resolution – 656 x 492
- Ball Guide – 2 included
- Sonde – 512 Hz
- Counter – Not available

| Catalog No. | Description | Weight | |
|-------------|--|--------|-----|
| | | lb. | kg |
| 40818 | nanoReel N85S / micro CA-300 System NTSC | 10.8 | 4.7 |
| 39998 | nanoReel N85S (CA-300) NTSC | 9.5 | 4.1 |
| 40008 | nanoReel N85S (SeeSnake) NTSC | | |

(SeeSnake) = the reel containing the pushcable and camera head with a connection cable for a SeeSnake monitor
 (CA-300) = the reel containing the pushcable and camera head with a connection cable for a CA-300 monitor

Standard Equipment

| Catalog No. Model No. | 40818 - |
|--|------------|
| 37888 - micro CA-300 Inspection Camera | • |
| 39998 - nanoReel N85S (CA-300) NTSC | • |

Accessories

| Catalog No. | Description | Weight | |
|-------------|---|--------|------|
| | | lb. | kg |
| 33108 | Interconnect Cable for SeeSnake Monitor | 13/20 | 0.31 |
| 33113 | Interconnect Cable for CA-300 Monitor | | |

Reels & Cameras



RIDGID® CROSSCHEK™ INSPECTION SYSTEM

The RIDGID CrossChek allows you to visually inspect where you've bored before you install the new utility, helping you reduce the likelihood of undetected cross bores.

- Designed for bore slots 1.75" to 3" wide.
- Easily integrated into your current boring process.
- Keep digital video documentation of each inspection.
- Works in most soil types, including wet clay and dry sand.

| Catalog No. | Description | Weight | |
|-------------|----------------------------|--------|-----|
| | | lb. | kg |
| 42323 | CrossChek Rig (nanoReel) | | - |
| 42328 | CrossChek Rig (microDrain) | 4 | |
| 42333 | CrossChek Rig (microReel) | | 1.8 |
| 49528 | CrossChek Rig (Mini Reel) | | |



Monitors & Recorders



SeeSnake® DVDPAK2 INSPECTION CAMERA MONITOR

Reliably monitor and record inspections in the most extreme conditions with the SeeSnake DVDPak2 Monitor.

- Design makes carrying your tools to the job site and stowing your monitor easier than ever.
- Takes the question out of what DVDs to use, and how to finalize correctly.
- Superior job site durability.
- Record inspections regardless of the availability of AC power.

SPECIFICATIONS

- Display – 5.7" LCD
- Resolution – 320 x 240
- Power Source – RIDGID® 18V Advanced Lithium 2 battery (optional) or AC plug
- Weight – 9.15 lbs. (4.2 kg)
- Length – 13.8" (35.1 cm)
- Width – 9.1" (23.11 cm)
- Height – 5.3" (13.5 cm)
- Input – Composite video in, built-in microphone
- Media Compatibility – DVD-R, DVD+R, DVD-RW, DVD+RW, DVD+R DL

| Catalog No. | Description | Weight | |
|-------------|--|--------|-----|
| | | lb. | kg |
| 32673 | DVDPak2 Monitor Only – 5.7" LCD (115V) | 8 | 3.6 |
| 33198 | DVDPak2 Monitor with Battery and Charger – 5.7" LCD (115V) | 12 | 5.4 |

Accessories

| Catalog No. | Description | Weight | |
|-------------|---|-----------------|-----|
| | | lb. | kg |
| 44848 | Set of (1) 2.0Ah Battery and (1) 120V Charger | 2 $\frac{1}{2}$ | 1.3 |
| 44853 | Set of (2) 2.0Ah Batteries and (1) 120V Charger | 3 $\frac{1}{2}$ | 1.7 |
| 45363 | AC Battery Adapter | 1 | 0.5 |

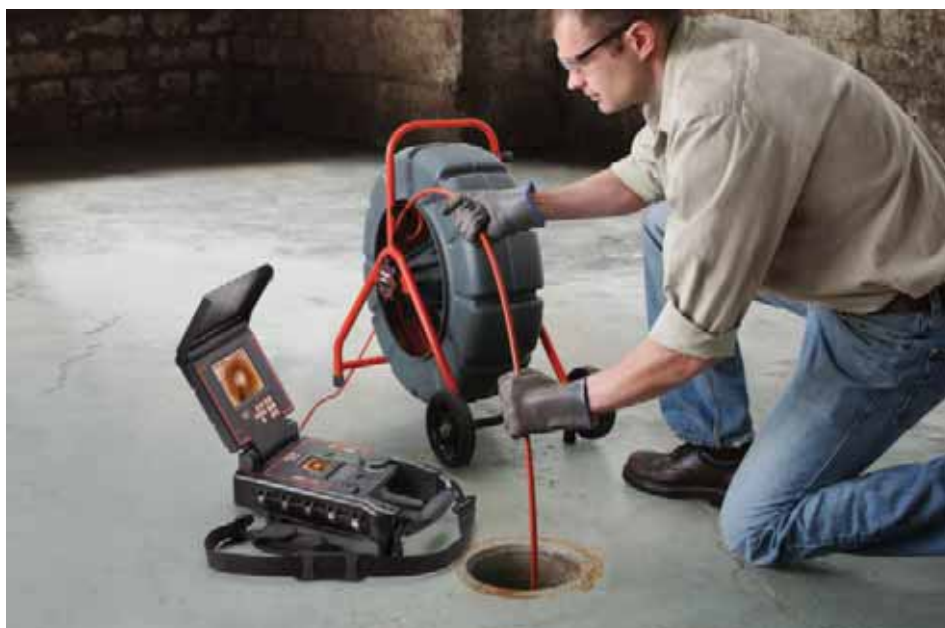

Monitors & Recorders



SeeSnake® CS10 DIGITAL RECORDING MONITOR

The CS10 Monitor combines durability with the easiest to use digital recording monitor in the industry. One touch recording allows you to record snapshots and video directly to a USB stick then hand it to your customer.

- Record digitally into a format that your customer can read on their computer.
- Easily monitor and record inspections in bright outdoor environments.
- Trace the reel push cable with a RIDGID® locator (requires a RIDGID transmitter).
- Take snapshots, record full frame video and record in a lean Auto-log video format (small files).
- With SeeSnake HQ™, deliver your inspections in a wide array of formats from online to DVD.

SPECIFICATIONS

- Weight – 13 lbs. (5.9 kg)
- Length – 14.3" (36.3 cm)
- Width – 11.9" (30.2 cm)
- Height – 12.4" (31.5 cm)
- Display – 12.1" daylight readable LCD
- Resolution – 640 x 480
- Power Source – 1 or 2 RIDGID 18V Advanced Lithium battery (optional) or AC plug
- Audio – Integrated microphone and speaker
- Video – AVI 20FPS - 720 x 480
- Image – JPG - 720 x 480
- Transfer – USB stick
- Software – Includes SeeSnake HQ Software

| Catalog No. | Description | Weight | |
|-------------|--|--------|-----|
| | | lb. | kg |
| 39338 | CS10 Monitor with 2 Batteries and Charger (115V) | 15.8 | 7.2 |
| 39328 | CS10 Digital Recording Monitor (115V) | 12 | 5.4 |

Batteries and Chargers

| Catalog No. | Description | Weight | |
|-------------|---|--------|-----|
| | | lb. | kg |
| 44848 | Set of (1) 2.0Ah Battery and (1) 120V Charger | 2.8 | 1.3 |
| 44853 | Set of (2) 2.0Ah Batteries and (1) 120V Charger | 3.8 | 1.7 |



Monitors & Recorders



SeeSnake® CS6 AND CS6PAK DIGITAL RECORDING MONITORS

Fast, Efficient Results

Capture still images and video clips and save directly to a USB thumbdrive and generate high quality multi-media reports.

The CS6 mounts to the SeeSnake MAX rM200 docking handle for easy transport and storage. The CS6Pak mounts to the Compact2 and can be quickly detached for convenient placement and storage. These are both compatible with all SeeSnake camera reels.

The CS6 and CS6Pak have the same great software and reporting capabilities in two distinct form factors.

- Fast, efficient documentation of inspection jobs.
- Direct control of essential camera and monitor functions.
- Crisp, clear in-pipe image.
- Edit, archive and deliver reports via print, DVD or online.
- Add custom job information and text notes.

SPECIFICATIONS

CS6

- Weight (without battery) – 3.6 lbs. (1.6 kg)
- Size – Length 14.2" (36 cm), Width 6.5" (16.5 cm), Height 5.1" (13.0 cm)
- Resolution – 640 x 480 (VGA) color LCD
- Display – 5.7" daylight readable LCD
- Video – MPEG4 (H.264) 30 FPS
- Autolog – MPEG4 (H.264) variable frame rate
- Image – JPEG
- Audio – Integrated microphone and speakers
- Transfer – USB thumb drive
- Power Source – 18V Advanced Lithium battery (optional) or AC adapter
- Operating Temperature – 14°F to 117°F (-10°C to 47°C)
- Storage Temperature – 14°F to 158°F (-10°C to 70°C)
- Relative Humidity – 5% to 95%
- Altitude – 13,120' (4,000 m)

CS6PAK

- Weight (without battery) – 5.7 lbs. (2.6 kg)
- Size – Length 14" (35.6 cm), Width 7.6" (19.3 cm), Height 10.6" (26.9 cm)
- Resolution – 640 x 480 (VGA) color LCD
- Display – 5.7" daylight readable LCD
- Video – MPEG4 (H.264) 30 FPS
- Autolog – MPEG4 (H.264) variable frame rate
- Image – JPEG
- Audio – Integrated microphone and speakers
- Transfer – USB thumb drive
- Power Source – 18V Advanced Lithium battery (optional) or AC adapter
- Operating Temperature – 14°F to 117°F (-10°C to 47°C)
- Storage Temperature – 14°F to 158°F (-10°C to 70°C)
- Relative Humidity – 5% to 95%
- Altitude – 13,120' (4,000 m)

| Catalog No. | Description | Weight | |
|-------------|---------------------------------------|--------|-----|
| | | lb. | kg |
| 45138 | CS6 Digital Recording Monitor | 3.6 | 1.6 |
| 45143 | CS6 with 2 Batteries and 1 Charger | 7.4 | 3.4 |
| 45158 | CS6Pak Digital Recording Monitor | 5.7 | 2.6 |
| 45163 | CS6Pak with 2 Batteries and 1 Charger | 9.5 | 4.3 |
| 45363 | AC Battery Adapter | 1 | 0.5 |

Accessories

| Catalog No. | Description | Weight | |
|-------------|---|--------|-----|
| | | lb. | kg |
| 44848 | Set of (1) 2.0Ah Battery and (1) 120V Charger | 2.8 | 1.3 |
| 44853 | Set of (2) 2.0Ah Batteries and (1) 120V Charger | 3.8 | 1.7 |

Monitors & Recorders



CS65 DIGITAL REPORTING MONITOR

Complete Reporting Solution.

One-touch image and video capture directly to one or two USB drives and the built-in 1 TB hard drive. The CS65 mounts to the SeeSnake Max rM200 for easy transport and storage.

Easily add on-screen titles and annotate captured media with the built-in keyboard and automatically generate high quality multimedia reports.

- One-touch recording for fast, efficient documentation of inspections.
- 1 TB internal hard drive provides ample storage for multiple jobs.
- PhotoTalk™ pairs audio commentary with an image, in an email-ready file.
- Daylight viewable display for a crisp, clear, in-pipe image.
- Water-resistant keyboard makes it easy to add onscreen titles and annotate reports.
- HQ Software to edit, archive, and deliver reports via print, DVD or online.

SPECIFICATIONS

- Weight (without battery) – 9.8 lbs. (4.4 kg)
- Length – 15.9" (403 mm)
- Width – 12.3" (312 mm)
- Height – 9.9" (251 mm)
- Power Source – 18V Advanced Lithium battery or AC adapter
- Power Rating – 16 to 25 VDC, 30W
- Operating Temperature – 14°F to 122°F (-10°C to 50°C)
- Storage Temperature – 4°F to 140°F (-20°C to 60°C)
- Relative Humidity – 5% to 95%
- Altitude – 13,120' (4,000 m)
- Display – 6.5" (165 mm) Color LCD
- Resolution – 640 x 480 VGA
- Video Format – MPEG4 (H.264) 30 FPS
- Autolog Format – MPEG4 (H.264) low, variable frame rate decreased file size
- Image Format – JPEG
- Audio – Integrated microphone and speakers
- Transfer – USB drive

| Catalog No. | Model No. | Description | Weight | |
|-------------|-----------|-------------------------------------|--------|-----|
| | | | lb. | kg |
| 48123 | CS65 | CS65 Digital Reporting Monitor | 9.5 | 4.3 |
| 48133 | CS65 | CS65 with 2 Batteries and 1 Charger | 13.3 | 6 |

Monitors & Recorders

NEW



CS65X DIGITAL REPORTING MONITOR

Introducing our first digital reporting monitor to include Wi-Fi and Bluetooth® connectivity. With the added ability to stream and/or record inspections to the latest iOS or Android device. One-touch recording for fast, efficient documentation of inspections.

- Stream or record inspections to an iOS or Android phone or tablet with the free HQx Live companion app Storage Options.
- Internal solid state drive provides ample storage of images and videos captured from multiple jobs.
- Dual USB ports makes for easy delivery of multiple copies of an inspection.
- Geotag media with positional information when available.
- Easily add on-screen titles and annotate reports.
- Daylight Viewable Display provides a crisp, clear, in-pipe image.

SPECIFICATIONS

- Weight (without battery) – 9.3 lbs. (4.2 kg)
- Length – 16" (406 mm)
- Width – 12.5" (319 mm)
- Height – 9.5" (242 mm)
- Power Source – 18V Advanced Lithium battery or AC power cable
- Power Rating – 15 to 25 VDC, 25W
- Operating Temperature – 14°F to 122°F (-10°C to 50°C)
- Storage Temperature – -4°F to 140°F (-20°C to 60°C)
- Relative Humidity – 5% to 95%
- Altitude – 13,120' (4,000 m)
- Display – 6.5" (165 mm) Color LCD
- Resolution – 640 x 480 VGA
- Video Format – MPEG4 (H.264) 30 FPS
- Autolog Format – MPEG4 (H.264) variable frame rate
- Image Format – JPEG
- Audio – Integrated microphone and speaker
- Transfer – USB drive

| Catalog No. | Model No. | Description | Weight | |
|-------------|-----------|--|--------|-----|
| | | | lb. | kg |
| 54363 | CS65x | CS65x Digital Reporting Monitor with Wi-Fi | 9.3 | 4.2 |
| 55978 | CS65x | CS65x with 2 Batteries and 1 Charger | 13.1 | 5 |

Monitors & Recorders



SeeSnake® DIGITAL LAPTOP INTERFACE

Leverage the power and flexibility of a laptop computer with the SeeSnake LT1000 and the SeeSnake Mini or Standard drain inspection cameras and reels. Use a laptop computer as a camera control unit to add powerful monitoring, recording, storage and communications capabilities.

- In recording, monitoring, and reporting. Unlock the power of your laptop to monitor, record and communicate.
- Keep gloved hands off the laptop keyboard while controlling camera operation and recording during an inspection.
- Perform inspections regardless of availability of AC power (Optional).
- Secure and stabilize your laptop and reel to protect it in the field (full LT1000 only).



SPECIFICATIONS

- Power Source – RIDGID® 18V Advanced Lithium battery (optional) or AC plug
- Outputs – USB video stream, RCA video and audio
- Controls – Sonde, lights, recording, image rotation, etc.



LT1000

The full LT1000 System mounts directly onto a SeeSnake Mini or Standard reel giving you a stacked and stable platform with a single cord interface.

- Compatibility – all SeeSnake Mini and Standard reels.
- Includes – SeeSnake HQ™ monitoring/recording software, reel mounting kit, 6' (1.8 m) USB cable, 4 reel outriggers (for stability), AC power cable.

LT1000M

The LT1000M is a detached interface interfaces with any SeeSnake reel.

- Compatibility – All SeeSnake reels.
- Includes – SeeSnake HQ monitoring/recording software, 3' (90 cm) USB cable, micro frame, AC power cable.



| Catalog No. | Description | Weight | |
|-------------|---|--------|-----|
| | | lb. | kg |
| 35973 | LT1000 Laptop Interface System (115V) | 6 | 2.7 |
| 35983 | LT1000 with Battery and Charger Kit (115V) | 7.4 | 3.3 |
| 36653 | LT1000M Laptop Interface System (115V) | 4.7 | 2.1 |
| 36663 | LT1000M with Battery and Charger Kit (115V) | 6 | 2.7 |

Batteries and Chargers

| Catalog No. | Description | Weight | |
|-------------|---|--------|-----|
| | | lb. | kg |
| 43458 | Advanced Lithium Battery Charger (N. America) | 1½ | 0.8 |
| 44693 | 18V Advanced Lithium 2.0Ah Battery | 1 | 0.5 |

Digital Interfaces



SeeSnakeHQ™ DIGITAL INSPECTION SOFTWARE

SeeSnake HQ is powerful installed software for monitoring, recording and managing digital inspection data in the field. Record and document your findings, burn DVDs and export to a USB drive. For the ultimate in digital flexibility, upload directly to RIDGIDConnect.com™ for easy communication and secure storage.

MONITOR AND RECORD

- Use your laptop as a large screen monitoring display.
- Record videos and images directly to your hard drive.
- Record your observations and control your inspection camera using the power of a laptop.

REPORT

- Document your observations and create a report of your findings.
- Store details about the job including contact information, observations, recommendations and notes.
- Customize the appearance of your reports to fit your company.

DELIVERY

- Upload your complete reports directly to your RIDGIDConnect.com account with one mouse click.
- Burn DVDs for your customers or hand them a USB drive.



Monitor and record your inspections.



Enhance and edit captured footage.

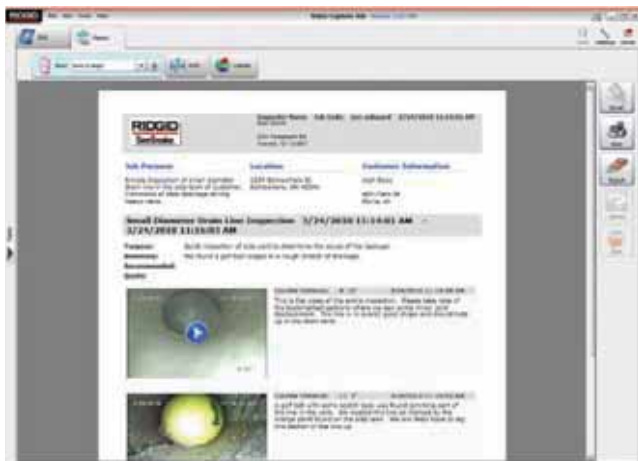

Generate detailed reports in the field.

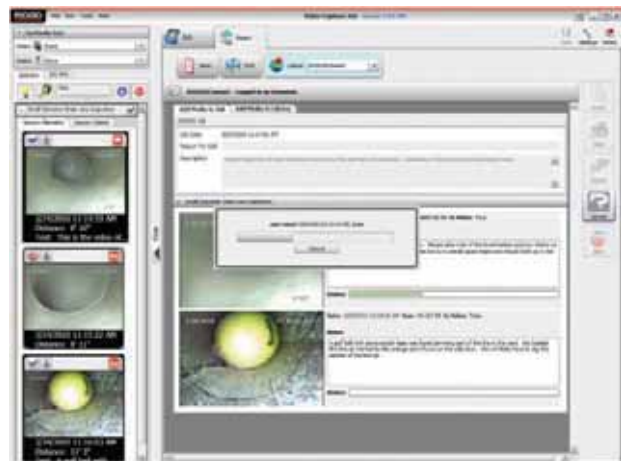

Upload your reports directly to RIDGIDConnect.

Digital Interfaces



ACCESS TO YOUR BUSINESS INFORMATION 24/7

With RIDGIDConnect you can have secure access to your data from any web browser. You can also work with your information in the field and create new reports via your mobile smartphone. Look up job reports, upload media from the phone or recall insights about a customer. RIDGIDConnect puts your business records at your fingertips.

RIDGIDConnect™ ONLINE BUSINESS TOOL

RIDGIDConnect is the online solution that streamlines your reporting process, integrates digital media and files into a hosted archive environment, and makes professional reports that you can share with anyone.

RIDGIDConnect ALLOWS YOU TO:

- Create job reports for one or many to see.
- Associate any type of digital file or media with a report to share.
- Tag your media for reference and quick look up.
- Edit video, extract frames as images and add image mark-ups to tell the story.
- Add bookmarks to videos to direct viewers to areas of interest.
- Control access to your information by expiration date or total number of views.
- Manage your customer list and associate geotags with provided addresses.
- Import address lists from any standard program.
- Choose QuickSend to upload and share the report all in one step.
- Desktop application to compress media prior to upload.
- Post level videos to compensate for camera heads that are not self-leveling.
- Keep company-only notes about jobs and customers to help recall service information.
- Schedule jobs, set reminders and dispatch work within your company.
- Enable your customers to upload media to a report so you can understand the issue before arriving on site.
- Seamlessly integrate job reports from SeeSnake HQ™ to your RIDGIDConnect account.
- Have daily backups and 24/7 access via web browser to all your information.

The RIDGIDConnect site is full of application ideas as well as screen casts and videos to help you quickly get started. Register for a Basic or higher level account to share all types of media or choose an Express account to share image-only reports. Visit www.ridgidconnect.com to get started.

| Catalog No. | Description |
|--|---|
| 37348 | RIDGIDConnect Annual Basic Subscription |
| See www.RIDGIDConnect.com For Monthly Subscription Plans. | |



Easy to navigate dashboard with all your activity.

Describe and bookmark your videos.

Hand-Held Video Inspection



micro CA-25 DIGITAL INSPECTION CAMERA

The RIDGID® micro CA-25 is a compact handheld inspection camera with a fixed 17 mm waterproof imager head for basic and short-range inspection jobs.

The micro CA-25 features a 17 mm aluminum imager head with 4 ultra-bright LED lights, bringing superior image quality to its 2.4" Color LCD Screen. It also features Video Out for transferring live images to external devices and 180° Digital Image Rotation for getting upright images. Included with the micro CA-25 in a hard shell plastic case are a hook, magnet, mirror and RCA cable.

SPECIFICATIONS

- Display – 2.4" color LCD (480 x 234 resolution)
- Camera Head – 17mm diameter, aluminum construction
- Lighting – 4 LEDs with adjustable brightness
- Cable Reach – 4' (120 cm), not extendable
- Video Output – 3' (90 cm) RCA cable (included)
- Image Rotation – 180°
- Waterproof – Camera head and cable to 4' (120 cm), not extendable
- Power Source – 4 AA batteries (included)
- Included Accessories – Mirror, hook and magnet, in a blow-molded case



| Catalog No. | Description | Weight | |
|-------------|-------------------------------|--------|-----|
| | | lb. | kg |
| 40043 | micro CA-25 Inspection Camera | 4.7 | 2.1 |

Replacement Parts

| Catalog No. | Description | Weight | |
|-------------|--|--------|----|
| | | lb. | kg |
| 37123 | Mirror, Hook & Magnet for 17mm Camera Head | 0.1 | 0 |

Hand-Held Video Inspection



micro CA-100 INSPECTION CAMERA

The RIDGID® micro CA-100 Inspection Camera, the next evolution of the SeeSnake® micro Inspection Camera, allows you to perform more detailed visual inspections in even harder-to-reach areas. Its comfortable pistol-grip design, one-hand controls, and large screen make it easy to see into the tightest spots. The micro CA-100 comes standard with a rugged 0.7" (17 mm) anodized aluminum camera head with four super bright LEDs to see into the darkest areas. Easily rotate the active image counter-clockwise to see in any situation. With an available 6 mm camera accessory, the micro CA-100 Inspection Camera allows you to service and identify problems in more places. The RIDGID micro CA-100 Inspection Camera provides solutions whenever and wherever you need them.

SPECIFICATIONS

- Display – 3.5" color LCD (320 x 240 resolution)
- Camera Head – 17 mm diameter, aluminum construction
- Lighting – 4 LEDs with adjustable brightness
- Cable Reach – 3' (90 cm) expandable to 30' (9 m) with optional extensions
- Video Output – 3' (90 cm) RCA cable (included)
- Image Rotation – 4 x 90°
- Waterproof – Camera head and cable to 10' (3 m)
- Power Source – 4 AA batteries (included)
- Attachments – Mirror, hook and magnet, in a blow-molded case

| Catalog No. | Description | Weight | |
|-------------|--------------------------------|--------|-----|
| | | lb. | kg |
| 36738 | micro CA-100 Inspection Camera | 5.5 | 2.5 |

Accessories

| Catalog No. | Description | Weight | |
|-------------|-----------------------------|--------|-----|
| | | lb. | kg |
| 37108 | Cable Extension 3' (90 cm) | 0.8 | 0.3 |
| 37098 | 6 mm Imager with 1 m Cable | 0.2 | 0.1 |
| 37093 | 6 mm Imager with 4 m Cable | 0.9 | 0.4 |
| 37113 | Cable Extension 6' (180 cm) | 1.5 | 0.7 |

**Not compatible with original micro inspection camera 25643 (rotary power switch design).*

Replacement Parts

| Catalog No. | Description | Weight | |
|-------------|--|--------|-----|
| | | lb. | kg |
| 37103 | 17 mm Replacement Imager 3' (90 cm) | 0.7 | 0.3 |
| 37123 | Mirror, Hook & Magnet for 17mm Camera Head | 0.1 | 0 |

Hand-Held Video Inspection



micro CA-300 INSPECTION CAMERA

Documentation made easy with the RIDGID® micro CA-300 Inspection Camera, the next evolution of the microEXPLORER®. Easily record still images and videos of problems in hard-to-reach areas and save these on the internal memory (235 MB) or the included 4 GB SD-card. Comfortable pistol-grip design, large screen and rugged anodized aluminum camera head with four bright LEDs make it easy to detect and diagnose the unreachable. Get the perfect view with enhanced features like image rotation and digital zoom. Besides the replaceable 3.7V Li-Ion battery, the micro CA-300 can also be powered with the included AC Adapter which is ideal for time consuming (drain) inspection jobs or when you simply run out of battery.

SPECIFICATIONS

- Display – 3.5" color LCD (320 x 240 resolution)
- Camera Head – 17 mm diameter, aluminum construction
- Lighting – 4 LEDs with adjustable brightness
- Cable Reach – 3' (90 cm) expandable to 30' (9 m) with optional extensions
- Image/Video Format – Still Image - JPEG (640 x 480). Video - MP4 (640 x 480 resolution)
- Video Output – 3' (90 cm) RCA cable included (640 x 480 resolution)
- Waterproof – Camera and cable to 10' (3 m) when properly assembled
- Power Source – 3.7V Li-Ion battery or 5V AC adapter
- Image Rotation – 4 x 90°
- Digital Zoom – Yes
- Internal Memory – 235 MB
- SD-card – Up to 32 GB (8 GB card included)
- Integrated audio recorder, speaker and headset

| Catalog No. | Description | Weight | |
|-------------|--|--------|-----|
| | | lb. | kg |
| 37888 | micro CA-300 Inspection Camera (North America Type A Plug) | 5.5 | 2.5 |

Accessories

| Catalog No. | Description | Weight | |
|-------------|-----------------------------|--------|------|
| | | lb. | kg |
| 37098 | 6 mm Imager with 1 m Cable | 0.22 | 0.1 |
| 37093 | 6 mm Imager with 4 m Cable | 0.88 | 0.4 |
| 37108 | Cable Extension 3' (90 cm) | 0.66 | 0.3 |
| 37113 | Cable Extension 6' (180 cm) | 1.5 | 0.68 |
| 30208 | Car Charger (DC) Adaptor | 0.26 | 0.12 |
| 40028 | AC Adapter, micro CA-300 | - | - |

**Not compatible with original micro inspection camera 25643 (rotary power switch design).*

Replacement Parts

| Catalog No. | Description | Weight | |
|-------------|--|--------|-----|
| | | lb. | kg |
| 37103 | 17 mm Replacement Imager 3' (90 cm) | 0.7 | 0.3 |
| 37123 | Mirror, Hook & Magnet for 17mm Camera Head | 0.1 | 0 |
| 37083 | micro CA-300 3.7 Li-Ion battery | 0.2 | 0.1 |
| 37088 | micro CA-300 3.7V Battery Charger | - | - |
| 40028 | AC Adapter, micro CA-300 | - | - |

Hand-Held Video Inspection



6 mm imager with 1 m cable



6 mm imager with 4 m cable



Mirror, hook and magnet for 6 mm camera head

6 MM DIAMETER IMAGER HEAD ACCESSORY

- 6 mm camera head, nearly one-third the size of the standard camera head.
- Enables detailed inspections in very confined spaces.
- 4 LED lights provide clear images.
- Fully flexible cables for easy navigation.
- Sleek aluminum construction withstands demanding applications.
- Compatible with: RIDGID® micro CA-100, micro CA-300, microEXPLORER™ and SeeSnake® micro systems.*

SPECIFICATIONS

- Camera Head – 6 mm Diameter, Aluminum Construction
- Compatibility – RIDGID® micro CA-100, micro CA-300, microEXPLORER, and SeeSnake micro*

| Catalog No. | Description | Weight | |
|-------------|----------------------------|--------|-----|
| | | lb. | kg |
| 37093 | 6 mm Imager with 4 m Cable | 0.9 | 0.4 |
| 37098 | 6 mm Imager with 1 m Cable | 0.2 | 0.1 |

Includes: Hook, Magnet and Mirror Accessory.

**Not compatible with original micro inspection camera 25643 (rotary power switch design).*

Replacement Parts

| Catalog No. | Description |
|-------------|---|
| 45358 | Mirror, Hook & Magnet for 6mm Camera Head |

Test and Measurement



micro IR-200 INFRARED THERMOMETER

The RIDGID® micro IR-200 Non-Contact Infrared Thermometer provides simple, quick and accurate surface temperature readings at the push of a button. Simply squeeze the trigger and point the ultra-sharp dual class II lasers at the surface being measured. The micro IR-100 provides an immediate temperature measurement on a clear, easy-to-read backlit LCD display. In addition to numerous other uses, this rugged and compact instrument enables professional tradesman to diagnose heating and ventilation problems, perform preventative monitoring of electrical motors and systems, troubleshoot steam traps and quickly check fuses or circuit breakers for overheating – all without contact.

- Ultra Sharp Dual Class II Lasers easily identify the surface area being measured.
- 30 To 1 Distance To Spot Ratio allows you to take more accurate measurements from a farther distance.
- Adjustable Emissivity to accurately measure the temperature of virtually any surface.
- Audible and Visual High and Low Alarms quickly alert you to temperatures outside of the ranges that you set.
- Bright Backlit Display which can be toggled on in poorly lit areas.
- Tripod Mount Capable for repeatable, precise temperature measurements.

SPECIFICATIONS

- Temperature Range – -58° to 2192°F (-50° to 1200°C)
- Measurement Accuracy – -58°F to 68°F (-50°C to 20°C) ±4.5°F (2.5°C); 68°F ~2192°F (20°C ~1200°C); ±1.0% or ±1.8°F (1.0°C)
- Distance To Spot Ratio – 30 to 1
- Response Time – <150ms
- Emissivity – Adjustable, 0.10 - 1.00
- Temperature Display – Current Temperature, MAX Temperature
- Measurement Units – Fahrenheit, Celsius
- Power Source – Battery (1 x “9V”) Included



| Catalog No. | Description | Weight | |
|-------------|---|--------|-----|
| | | lb. | kg |
| 36798 | micro IR-200 Non-Contact Infrared Thermometer | 0.5 | 0.2 |

Test and Measurement



micro LM-100 LASER DISTANCE METER

The RIDGID® micro LM-100 Laser Distance Meter provides simple, quick and accurate distance readings at the push of a button. Simply push the measurement button to turn on the ultra-sharp Class II lasers, point the device at the spot to be measured, and push the measurement button. The distance reading will appear on the easy-to-read LCD display. This rugged, compact, portable instrument enables professional tradesman to quickly determine distances for piping, measuring trouble spots down the line, and quickly determine spacing for code compliance.

- Ultra Sharp Class II Lasers clearly highlight the point being measured.
- Exceptional distance range allows accurate measurements up to 164' (50 m).
- Adjustable units enable you to quickly read feet, inches or meters on the fly.
- Bright backlit display for use in poorly lit areas.
- Quick and accurate calculations on the spot.
- Displays the last three measurements, stores the last 20 measurements.
- Rubberized over-molding for a solid grip.

SPECIFICATIONS

- Measurement Accuracy – $\pm 1/16"$ (1.5 mm)
- Range – 164 ft. (50 m)
- Measurement Units – Inches, feet and meters
- Measurement Calculations – Area, volume and indirect measurement calculations
- Power Source – 2 AAA batteries (included)
- Ruggedness – IP 54 dust proof, splash proof



| Catalog No. | Model No. | Description | Weight | |
|-------------|--------------|----------------------|--------|-----|
| | | | lb. | kg |
| 36158 | micro LM-100 | Laser Distance Meter | 0.5 | 0.2 |

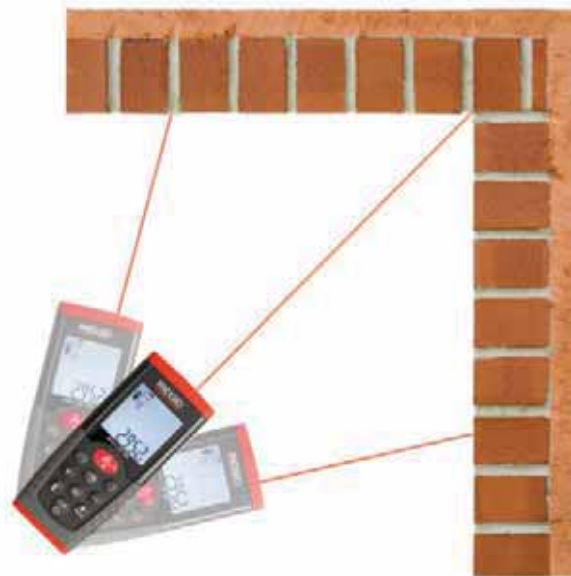

Test and Measurement



micro LM-400 ADVANCED LASER DISTANCE METER

View, Store and Share.

Quick distance readings and advanced calculations are at your fingertips. Connect to a smartphone or tablet to overlay measurements on a photo or sketch to share with others.

- Clearly view measurements on the large, backlit, 4-line display.
- Inclination angle measurement allows indirect measurements for hard to reach areas.
- Adjust units instantly to inches, feet or meters.
- Bluetooth® connection to smartphones and tablets to view, store, and share data.
- Android® and iOS® Apps to overlay measurements onto a photo or sketch.

SPECIFICATIONS

- Measuring Accuracy – $\pm \frac{1}{16}$ inch (± 1.5 mm)
- Range – 229 feet (70 m)
- Measuring Units – Inches, feet and meters
- Angle Range – $\pm 65^\circ$
- Angle Accuracy – ± 0.5
- Bluetooth Range – 33 ft (10 m)
- Ruggedness – IP 54 dust proof, splash proof
- Memory Storage – 20 measurements
- Batteries – 2 AA (included)
- Automatic Shut-Off – After 3 minutes of inactivity
- Case – Includes soft carrying case



| Catalog No. | Description | Weight | |
|-------------|-----------------------------------|--------|------|
| | | lb. | kg |
| 36813 | micro LM-400 Laser Distance Meter | 0.44 | 0.22 |

RIDGIDSKETCH

RIDGIDsketch is a tool for mobile devices that allows you to calculate and communicate measurements of your project. It can be used on its own or in conjunction with a RIDGID LM-400 Laser Distance Meter. The app will connect to your LM-400 via Bluetooth® and wirelessly receive the exact measurements from the device. RIDGIDsketch works in both drawing mode and photo overlay mode allowing you to develop precise room plans or annotate measurements within a photo.



RIDGID is the trademark of Emerson Electric Co. or its affiliates and is registered in the U.S. and elsewhere. All third-party trademarks are those of their respective owners.

The Bluetooth® word mark and logos are registered trademarks owned by Bluetooth SIG, Inc. and any use of such marks by Emerson Electric Co. is under license. Other trademarks and trade names are those of their respective owners.

iOS is registered trademark of Apple Inc.

Android and the Android logo are trademarks of Google Inc.

Test and Measurement



micro CD-100 COMBUSTIBLE GAS DETECTOR

The RIDGID® micro CD-100 Combustible Gas Detector provides simple and quick readings to identify the presence of combustible gases. With adjustable sensitivity, even low-levels of gases can be detected in seconds. It ensures proper gas line installations, checks for maintenance and repair needs and quickly pinpoints combustible gas leaks.

- Rugged ergonomic design makes it comfortable to use, yet tough.
- Tri-Mode Detection™ for option to be alerted with a visual, audible or vibration alerts which can be adjusted for your environment.
- Adjustable sensitivity settings provide precise leak locating with the touch of a button.
- 16" (40 cm) flexible probe allows location and detection of leak in hard-to-reach and confined spaces.
- Field replaceable sensor means more up-time and less time waiting for repairs.

SPECIFICATIONS

- Detection Range – 0 to 6400 ppm (Methane)
- Alarm Sensitivity – 40 ppm (Methane)
- Calibration – Automatic
- Alarms – Visual, audible and vibration
- Power Source – 4 x AA batteries (included)
- Gases Detected* – Methane, Hydrogen, Propane, Ethylene, Ethane, Hexane, Iso-Butane, Benzene, Iso-Butane, Ethanol, Acetaldehyde, Toluene, P-Xylene, Ammonia, Hydrogen Sulfide

**Common mixtures that would include or emit more than one of these gases include natural gas, paint thinners, industrial solvents, dry cleaning fluids, and gasoline.*









| Catalog No. | Model No. | Description | Weight | |
|-------------|--------------|--------------------------|--------|------|
| | | | lb. | kg |
| 36163 | micro CD-100 | Combustible Gas Detector | 1 | 0.45 |
| 31948 | CD-100 RS | Replacement Sensor | - | - |







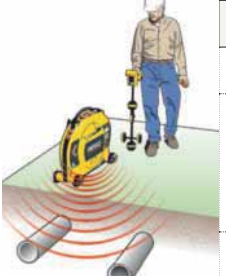

Locating Equipment

RIDGID® Receivers – RIDGID® locating receivers feature an easy-to-use visual mapping display that allows you to locate utility lines and sondes/beacons with confidence. Use with a SeeSnake® camera equipped with a sonde transmitter to locate the camera head during an inspection or use with a line transmitter to find buried utilities. These locators can also find flushable float sondes and remote transmitters attached to a push rod or drain cable.

| | UTILITY LOCATING | | | PLUMBING LOCATING | |
|---|---|---|---|---|---|
| | SeekTech® SR-60 | SeekTech® SR-24 | SeekTech® SR-20 | NaviTrack® II | NaviTrack Scout® |
|  |  |  |  |  |  |
| Page Number | 22163 | 44473 | 21893 | 96967 | 19238 |
| | 12.33 | 12.32 | 12.31 | 12.36 | 12.37 |
| Omni-Directional Mapping Display | Yes | Yes | Yes | Yes | Yes |
| User-Defined Frequencies | Yes - All Available | Yes up to 35 kHz | Yes up to 35 kHz | No | No |
| Number of Active Line Trace Frequencies | All up to 490 kHz | All up to 35 kHz | All up to 35 kHz | 7 | 3 |
| Sonde Frequencies | All up to 490 kHz | All up to 35 kHz | All up to 35 kHz | 7 | 4 |
| Passive Search | Omni-Seek (searches all passive bands at once) | Omni-Seek (searches all passive bands at once) | Omni-Seek (searches all passive bands at once) | 50/60 Hz | 50/60 Hz |
| Depth | Continuous | Continuous | Continuous | Continuous | Push Button |
| Weight w/batteries | 5.1 lbs./2.3 kg | 4 lbs./1.8 kg | 4 lbs./1.8 kg | 5.1 lbs./2.3 kg | 3 lbs./1.4 kg |
| Bluetooth®/GPS | No | Yes | No | No | No |

RIDGID® Transmitters – Accurately trace buried utilities by applying a signal with a RIDGID® Line Transmitter. All transmitters have multiple frequency options and are capable of applying a signal by direct connection and induction. Powerful 5W and 10W transmitters apply a strong signal making for easier locates.

| | UTILITY LOCATING | | | PLUMBING LOCATING | |
|---|---|---|---|---|---|
| | SeekTech ST-33Q+ | SeekTech ST-510 | SeekTech ST-305 | NaviTrack | Brick |
|  |  |  |  |  |  |
| Page Number | 49338 | 21903 | 21898 | 14818 | 20168 |
| | 12.34 | 12.35 | 12.35 | 12.38 | 12.38 |
| Max Power Output | 10W | 10W | 5W | 10W | 5W |
| Digital Display | Yes | Yes | No | No | No |
| Line Trace Frequencies | All up to 490 kHz | Selections up to 490 kHz | 4 | 6 | 4 |
| Inductive Frequencies | 8 kHz or 33 kHz | 4 | 3 | 6 | 3 |
| Simultaneous Transmit 2 Line Frequencies | No | No | Yes | No | Yes |
| Weight w/batteries | 11.1 lbs./5.0 kg | 8 lbs./3.4 kg | 2.4 lbs./1.1 kg | 9 lbs./4.1 kg | 2 lbs./0.9 kg |
| Bluetooth®/GPS | Yes | No | No | No | No |
| Rechargeable Batteries | Yes | No | No | No | No |



Find sondes/beacons



Direct connect to utility lines

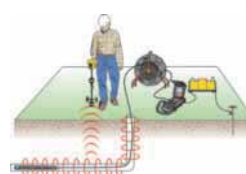

Find plastic pipe with integral line trace



Induce a signal to locate utilities

SeekTech® Utility Line Locators

The large displays on SeekTech receivers give you the information you need when you need to locate with speed, accuracy and confidence.



PERFORMANCE

The mapping display confirms a good locate signal and identifies distortion in congested areas using:

- Target-Line – Guides the operator down the line and shows changes in direction.
- Left-Right Guidance Arrows – Points the operator to the target utility.
- Proximity Signal and Signal Strength – Helps the operator center the locator closer to the target for more confident locates.

OTHER FEATURES

- Continual Depth – Increases productivity by showing depth changes in real-time.
- Omni-Seek® – Increases accuracy and efficiency when searching in passive mode. Continuously searches passive power and radio bands to locate and avoid unknown metallic lines.
- User-Defined Frequencies – RIDGID SeekTech receivers can be configured with up to 30 user-defined frequencies.
 - SeekTech SR-60 locator can be set to any frequency between 10 Hz and 490,000 Hz making it a universal receiver.
 - SeekTech SR-20 locator can be set to any frequency between 10 Hz and 35,000 Hz.

Comparison of Features

| | SR-20 Locator | SR-24 Locator | SR-60 Locator | Conventional |
|---|---------------------------------|---------------------------------|---------------------------------|------------------------------|
| Omni-Directional Mapping Display | Yes | Yes | Yes | No |
| User-Defined Frequencies (Competitor Frequencies) | Yes up to 35 K | Yes up to 35 K | Yes – All Available | Limited or No |
| Omni-Seek® (Simultaneous Multiple Line Trace) | Yes – All Passive Bands at Once | Yes – All Passive Bands at Once | Yes – All Passive Bands at Once | No |
| Depth | Continual | Continual | Continual | Push Button or Triangulation |
| Current Measurement | Continual | Continual | Continual | Push Button & Average |
| Distortion Indication On One Screen | Yes | Yes | Yes | No |
| Simultrace™ (Simultaneous Sonde & Line Trace) | No | No | Yes | No |
| Stereo Guidance (Using Headphones) | No | No | Yes | No |
| Integrated Bluetooth and GPS | No | Yes | No | No |

Utility Locating



SEEKTECH SR-20 LOCATOR

A lightweight yet rugged receiver that provides all the information needed for faster, more accurate locates.

- Target line and guidance arrows quickly identify distortion.
- Proximity signal and signal strength help work through difficult locates.
- Trace any frequency from 10 Hz to 35,000 kHz.

SPECIFICATIONS

- Active Line Trace Frequencies * – 128 Hz, 1 kHz, 8 kHz and 33 kHz
- Passive Power Trace – 50 Hz, 60 Hz, <4 kHz Broadband
- Passive Radio Trace – 4 kHz-15 kHz, 15 kHz-36 kHz
- Sonde Frequencies * – 16 Hz, 512 Hz, 640 Hz, 850 Hz, 8 kHz, 16 kHz, 33 kHz
- Power Source – 4 C-Cell batteries (included)
- Battery Life – Approximately 16 hours
- Weight – 3.5 lbs. (1.6 kg)
- Meets FCC Class A and EN 55022 Class A requirements

* 30 user definable frequencies can be set from 10 Hz to 35,000 kHz.

| Catalog No. | Description | Weight | |
|-------------|---|--------|-----|
| | | lb. | kg |
| 21893 | SeekTech SR-20 Line Locator (Includes Case) | 4 | 1.8 |
| 46918 | KIT: SR-20 + ST305 + 4" CLAMP | 8.5 | 3.8 |

Accessories

| Catalog No. | Description | Weight | |
|-------------|---|--------|-----|
| | | lb. | kg |
| 20973 | SeekTech 4" (100 mm) Inductive Signal Clamp | 2 | 0.9 |
| 21898 | SeekTech ST-305 Transmitter | 2.5 | 1.9 |

Replacement Parts

| Catalog No. | Description | Weight | |
|-------------|------------------|--------|-----|
| | | lb. | kg |
| 22173 | SR-20/SR-24 Case | 5 | 2.2 |

Utility Locating



RIDGIDTRAX

RIDGIDtrax enables basic underground utility mapping in real time. Connect an Android or iOS device wirelessly to a RIDGID SR-24 Utility Locator and RIDGIDtrax will display GPS position and depth of the target utility. A user can identify the type of utility (water, gas, electric, etc.) and display multiple utilities on the same map. A finished map can be saved and viewed inside the app or exported to a *.KMZ file for use with popular GIS programs such as Google Earth®.



RIDGIDtrax



SR-24 LINE LOCATOR WITH BLUETOOTH® AND GPS

The SR-24 is a precision utility locating instrument with GPS and Bluetooth® technology for easy integration with external data capture devices.

The SR-24's omnidirectional antennas capture the complete signal field, making it easy to acquire the signal and trace its path. The receiver displays the utility's position and direction on the display, providing an intuitive locating experience. For added confidence, audio and visual warnings notify the operator if the shape of the signal field is being distorted so that appropriate action can be taken to avoid mismarking the utility's position.

- Shows the utility's estimated position, direction and depth.
- Capture the complete signal field for greater speed and accuracy.
- Track location coordinates for mapping and GIS applications.
- Stream data to smartphones, tablets, or high-precision GPS instruments.
- Map multiple tracks and waypoints and export to GIS software.

SPECIFICATIONS

- Active Line Trace Frequencies* – 128 Hz, 1 kHz, 8 kHz and 33 kHz
- Passive Power Trace – 50 Hz, 60 Hz, <4 kHz Broadband
- Passive Radio Trace – 4 kHz-15 kHz, 15 kHz-36 kHz
- Sonde Frequencies * – 16 Hz, 512 Hz, 640 Hz, 850 Hz, 8 kHz, 16 kHz, 33 kHz
- Power Source – 4 C-Cell batteries (included)
- Battery Life – Approximately 16 hours
- Weight – 3.5 lbs. (1.6 kg)
- Wireless Technology – Bluetooth Class 1
- Wireless Range – 200 yards (183 meters)
- GPS Average Accuracy – Less than 8.2' (2.5 m)
- Meets FCC Class A and EN 55022 Class A requirements

* 30 user definable frequencies can be set from 10 Hz to 35,000 Hz.

| Catalog No. | Description | Weight | |
|-------------|--|--------|-----|
| | | lb. | kg |
| 44473 | SR-24 Line Locator with Bluetooth® and GPS | 4 | 1.8 |

Accessories

| Catalog No. | Description | Weight | |
|-------------|---|--------|-----|
| | | lb. | kg |
| 21898 | SeekTech ST-305 Transmitter | 2.5 | 1.9 |
| 20973 | SeekTech 4" (100 mm) Inductive Signal Clamp | 2 | 0.9 |

Replacement Parts

| Catalog No. | Description | Weight | |
|-------------|------------------|--------|-----|
| | | lb. | kg |
| 22173 | SR-20/SR-24 Case | 5 | 2.2 |

Utility Locating



SEEKTECH® SR-60 LOCATOR

For the fastest, easiest, most versatile receiver available.

Choose the SR-60 locator for fast confident locates even under tough locate conditions (poor conductors, poor soil conditions, poor grounding, etc.).

VERSATILITY

- Trace any frequency from 10 Hz to 490 kHz.
- Trace energized lines and sondes (beacons) simultaneously.
- Has all the ease of use and accuracy of the SR-20 but with ALL locatable frequencies.

SPECIFICATIONS

- Active Line Trace Frequencies* – 128 Hz, 1 kHz, 8 kHz, 33 kHz, 51 kHz, 93 kHz, 200 kHz, 262 kHz**
- Passive Power Trace – 50 Hz, 60 Hz, <4 kHz Broadband
- Passive Radio Trace – 4 kHz-15 kHz, 15 kHz-36 kHz
- Sonde Frequencies * – 16 Hz, 512 Hz, 640 Hz, 850 Hz, 8 kHz, 16 kHz, 33 kHz
- Power Source – 4 C-Cell batteries (included)
- Battery Life – Approximately 16 hours
- Weight – 5.1 lbs. (2.3 kg)
- Meets FCC Class A and EN 55022 Class A requirements

*30 user definable frequencies can be set from 10 Hz to 490 kHz.
** Up to 93 kHz for devices sold in Europe.

| Catalog No. | Description | Weight | |
|-------------|---|--------|-----|
| | | lb. | kg |
| 22163 | SeekTech SR-60 Line Locator (Includes Case) | 5.1 | 2.3 |

Accessories

| Catalog No. | Description | Weight | |
|-------------|---|--------|-----|
| | | lb. | kg |
| 20973 | SeekTech 4" (100 mm) Inductive Signal Clamp | 2 | 0.9 |
| 21898 | SeekTech ST-305 Transmitter | 2.5 | 1.9 |

Replacement Parts





| Catalog No. | Description | Weight | |
|-------------|-------------|--------|-----|
| | | lb. | kg |
| 29798 | SR-60 Case | 5 | 2.2 |

SeekTech® Utility Transmitters

RIDGID® offers a range of transmitters for tracing underground metallic pipes and cables. All RIDGID® transmitters generate a signal onto the buried cable in one of three ways:

- Direct connection using connection cords.
- Induction with the optional inductive signal clamp.
- Induction from the transmitter.

Comparison of Features

| | UTILITY LOCATING | | |
|---|---|---|---|
| | SeekTech ST-33Q+ | SeekTech ST-510 | SeekTech ST-305 |
|  |  |  |  |
| | 49338 | 21903 | 21898 |
| Page Number | 12.34 | 12.35 | 12.35 |
| Max Power Output | 10W | 10W | 5W |
| Digital Display | Yes | Yes | No |
| Line Trace Frequencies | All up to 490 kHz | Selections up to 490 kHz | 4 |
| Inductive Frequencies | 8 kHz or 33 kHz | 4 | 3 |
| Simultaneous Transmit 2 Line Frequencies | No | No | Yes |
| Weight w/batteries | 11.1 lbs./5.0 kg | 8 lbs./3.4 kg | 2.4 lbs./1.1 kg |
| Bluetooth®/GPS | Yes | No | No |
| Rechargeable Batteries | Yes | No | No |



ST-33Q+ LINE TRANSMITTER WITH BLUETOOTH®

The RIDGID® ST-33Q+ Line Transmitter with Bluetooth is the ideal transmitter for inducing current onto a target line. It will also direct connect using any frequency from 10Hz to 490kHz* with power up to 10 Watts. The ST-33Q+ also allows the flexibility of using D-Cell alkaline batteries or 18V rechargeable RIDGID batteries for minimal interruptions on the job. The new Bluetooth feature on the ST-33Q+ allows you to finish complex locates faster by wirelessly changing the transmitted frequency from the SR-24 receiver from up to 200 yards away.

- Induce over 8 times more current than traditional transmitters. More current means you can walk and trace further than ever before.
- Power options include Lithium-Ion 18 V rechargeable battery, six D-cell batteries, or an external 10-28 VDC power source.
- Induce more current at lower frequencies. Lower frequencies are less prone to jump onto other lines in congested areas reducing distortion and increasing accuracy.
- Use with a SR-24 Bluetooth-enabled locator, to control the ST-33Q+ settings wirelessly from the SR-24 receiver. Change transmitted frequency remotely from up to 200 yards away.

FREQUENCIES

- Direct Connect (pre-programmed) – 128 Hz, 1 kHz, 8 kHz, 33 kHz, 93 kHz, 262 kHz*
- Direct Connect (user programmed) – Any Frequency from 10 Hz – 490 kHz*
- Induction – 8 kHz or 33 kHz

* Up to 93 kHz for devices sold in Europe and Australia and New Zealand.

SPECIFICATIONS

- Max Power – 10 watts
- Bluetooth Max Wireless Range – 200 yards (183 m)

Batteries sold separately.

| Catalog No. | Description | Weight | |
|-------------|---|--------|-----|
| | | lb. | kg |
| 49338 | ST-33Q+ Line Transmitter with Bluetooth | 11.1 | 5 |
| 20973 | SeekTech 4" (100 mm) Inductive Signal Clamp | 2 | 0.9 |
| 44853 | Set of (2) 2.0Ah Batteries and (1) 120V Charger | 4 | 1.7 |



Utility Locating



SEEKTECH ST-510 LINE TRANSMITTER

The SeekTech ST-510 Line Transmitter lets you energize metallic lines for tracing with a locator.

- Ten watts of fully variable power output.
- LCD display provides instant visual feedback on line resistance and current flow.
- Two 25' (7,62 m) lead wires with heavy duty clips.
- Audio feedback confirms a good circuit before beginning a trace.

SPECIFICATIONS

- Direct Connect – 128 Hz, 1 kHz, 8 kHz, 33 kHz and 93 kHz
- Induction – 1 kHz, 8 kHz, 33 kHz, 262 kHz*
- Competitor Frequencies – Available in both direct connect and induction

** Up to 93 kHz for devices sold in Europe.*

| Catalog No. | Description | Weight | |
|-------------|--|--------|-----|
| | | lb. | kg |
| 21903 | SeekTech ST-510 Transmitter (10 watts) | 8 | 3.4 |



SEEKTECH ST-305 LINE TRANSMITTER

The 5 watt SeekTech ST-305 Line Transmitter lets you energize metallic lines for tracing.

- Lightweight and compact transmitter that delivers up to 5 watts of power.
- Can transmit two frequencies simultaneously.
- Audio feedback confirms a good circuit before beginning a trace.

FREQUENCIES

- Direct Connect – 1 kHz, 8 kHz, 33 kHz, 262 kHz*
- Induction – 1 kHz, 8 kHz, 33 kHz, 262 kHz*

** Up to 93 kHz for devices sold in Europe.*

| Catalog No. | Description | Weight | |
|-------------|-----------------------------|--------|-----|
| | | lb. | kg |
| 21898 | SeekTech ST-305 Transmitter | 2.5 | 1.9 |



SEEKTECH INDUCTIVE SIGNAL CLAMP

- Allows users to apply a signal to a cable or pipe when direct connection is not possible.
- Compatible with all RIGID® transmitters.

| Catalog No. | Description | Weight | |
|-------------|---|--------|-----|
| | | lb. | kg |
| 20973 | SeekTech 4" (100 mm) Inductive Signal Clamp | 2 | 0.9 |

Utility Locating

NEW



MR-10 MAGNETIC LOCATOR

- Quickly locate buried iron or steel objects such as: Valve/Curb Boxes, Manhole Covers, Cast Iron Pipes, Steel Enclosures, Well Casings, Reinforced Septic Tanks, Survey Pins.
- Ergonomic rugged design includes carrying case and batteries.
- Highly sensitive instrument with audio and visual feedback.
- AutoNull feature blocks out nearby metallic interference such as an automobile or chain link fences.

SPECIFICATIONS

- Display – Black and White LCD
- Speaker – Durable Mylar Speaker
- Body Material/Construction – Aluminum Tube with Recessed Controls
- Length – 39.25" (100 cm)
- Operating Temperature – 0°F to +120°F (-18°C to +49°C)
- Storage Temperature – 13°F to +140°F (-25°C to +60°C)
- IP Protection – IP54
- Power Supply – 6 x AA Alkaline Batteries Included
- Weight – 1.7 lbs. (0,77 Kg)

| Catalog No. | Description | Weight | |
|-------------|----------------------------------|--------|------|
| | | lb. | kg |
| 53068 | MR-10 Magnetic Locator with Case | 1.7 | 0.77 |

NaviTrack® Locators



Kit shown without optional accessories

NAVITRACK II LOCATOR

NaviTrack II locators provide unprecedented ease-of-use for locating underground pipes. NaviTrack II's advanced technology greatly reduces training time. You can learn to locate with NaviTrack II in minutes.

- Locates SeeSnake in-line transmitters, remote transmitters (sondes), and energized metallic lines.
- Transmitters can be approached from any direction for faster, more accurate locates.
- Locates can be easily verified using the large mapping display.
- Continuous depth measurement.

SPECIFICATIONS

- Weight – 5 lbs
- Power Source – 4 C-Cell batteries
- Battery Life – Approximately 16 hours

STANDARD FREQUENCIES

- Sonde – 16 Hz, 512 Hz, 640 Hz, 850 Hz, 8 kHz, 16 kHz, 33 kHz
- Active Line Trace – 128 Hz, 1 kHz, 8 kHz, 33 kHz, 262 kHz
- Passive AC Line Trace – 60 Hz, 50 Hz

| Catalog No. | Description | Weight | |
|-------------|----------------------|--------|-----|
| | | lb. | kg |
| 96967 | NaviTrack II Locator | 5.1 | 2.3 |

Replacement Parts

| Catalog No. | Description |
|-------------|----------------------------|
| 12543 | Marker Chips and Clip |
| 22388 | NaviTrack II Carrying Case |

Accessories

| Catalog No. | Description | Weight | |
|-------------|---|--------|------|
| | | lb. | kg |
| 14818 | NaviTrack Line Transmitter | 8 | 3.4 |
| 16728 | Remote Transmitter, 512-AAA | | |
| 19793 | Float Sondes (2), Plus Extra Battery | 0.4 | 0.18 |
| 20168 | NaviTrack Brick Transmitter | | |
| 20973 | SeekTech 4" (100 mm) Inductive Signal Clamp | 2 | 0.9 |

NaviTrack® Locators

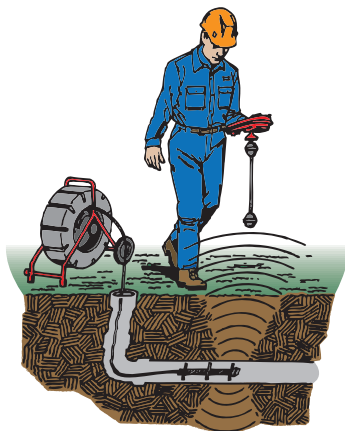

NAVITRACK SCOUT® LOCATOR

The NaviTrack Scout Locator is designed to solve the most demanding remote transmitter (sonde) locates using multi-directional locating technology.

EASIER LOCATES

- The NaviTrack Scout multi-directional antenna technology sees the entire signal all of the time. Simply maximize the signal strength and you have found the target. No nulls or false peaks to complicate the locate.

ACCURACY

- This locator verifies the locate position using a micro-mapping display to mark distinctive poles in front of and behind the target, insuring an accurate locate.

AUTOMATIC DEPTH

- Depth is automatically calculated and displayed when over the target.

SPECIFICATIONS

- Weight – 3 lbs (1.4 kg)
- Power Source – 4 C-Cell batteries
- Battery Life – Approximately 24 hours

STANDARD FREQUENCIES

- Sonde – 16 Hz, 512 Hz, 640 Hz, 874 kHz and 33 kHz
- Line Trace – 128 Hz, 1 kHz, 8 kHz and 33 kHz
- Passive AC Line Trace – 60 Hz, 50 Hz
- Meets FCC Class B and EN 55022 Class B requirements

| Catalog No. | Description | Weight | |
|-------------|-------------------------|--------|-----|
| | | lb. | kg |
| 19238 | NaviTrack Scout Locator | 3 | 1.4 |

Accessories

| Catalog No. | Description | Weight | |
|-------------|--------------------------------------|--------|------|
| | | lb. | kg |
| 14818 | NaviTrack Line Transmitter | 7.5 | 3.4 |
| 16728 | Remote Transmitter, 512-AAA | 0.4 | 0.18 |
| 19793 | Float Sondes (2), Plus Extra Battery | | |
| 20168 | NaviTrack Brick Transmitter | 2 | 0.9 |

Replacement Parts

| Catalog No. | Description |
|-------------|-----------------------|
| 12543 | Marker Chips and Clip |
| 20248 | Scout Carrying Case |

NaviTrack® Transmitters



NAVITRACK LINE TRANSMITTER - 10 WATT

For tracing buried cable, TV lines, phone lines and other metallic lines which can carry an electromagnetic signal.

- Up to 10 watts of power output.
- Two 25' coiled connectors.
- Conductive ground rod.
- Inductive signal clamp (optional accessory).

SPECIFICATIONS

- Frequencies – 128 Hz, 1 kHz, 8 kHz, 33 kHz – 10 watt
200 kHz, 262 kHz – 1 watt output power
- Power Source – 8 D-Cell batteries

| Catalog No. | Description | Weight | |
|-------------|----------------------------|--------|-----|
| | | lb. | kg |
| 14818 | NaviTrack Line Transmitter | 8 | 3.4 |

Accessories

| Catalog No. | Description | Weight | |
|-------------|---|--------|-----|
| | | lb. | kg |
| 20973 | SeekTech 4" (100 mm) Inductive Signal Clamp | 2 | 0.9 |



NAVITRACK BRICK - 5 WATT

- For tracing buried cable, TV lines, phone lines and other metallic lines which can carry an electromagnetic signal.
- Fully variable 5 watts of power output.
- Lightweight, easy to carry.
- Conductive ground rod.
- Two 10' connectors.

SPECIFICATIONS

- Frequencies – 1 kHz, 8 kHz, 33 kHz, 262 kHz
- Power Source – Six C-Cell batteries

| Catalog No. | Description | Weight | |
|-------------|-----------------------------|--------|-----|
| | | lb. | kg |
| 20168 | NaviTrack Brick Transmitter | 2 | 0.9 |

Accessories

| Catalog No. | Description | Weight | |
|-------------|---|--------|-----|
| | | lb. | kg |
| 20973 | SeekTech 4" (100 mm) Inductive Signal Clamp | 2 | 0.9 |

NaviTrack® Transmitters



REMOTE TRANSMITTER (512 HZ SONDE)

- Can be attached to a drain cleaning cable or a water jet hose to locate the remote transmitter in a line.
- Flashing LED indicates that sonde is transmitting.
- Meets FCC Class B and EN 55022 Class B requirements.

| Catalog No. | Description | Weight | |
|-------------|-----------------------------|--------|------|
| | | lb. | kg |
| 16728 | Remote Transmitter, 512-AAA | 0.4 | 0.18 |

Accessories

| Catalog No. | Description |
|-------------|--|
| 19258 | Adapter for 1¼" (32 mm) Sectional Cable |
| 19263 | Adapter for 5⁄8" and ¾" (16 mm and 20 mm) Drum Machine Cables |
| 19268 | Adapter for 7⁄8" (22 mm) Sec. and ½" (12 mm) Drum Machine Cables |
| 19273 | Adapter for 5⁄8" (16 mm) Sec. and 3⁄8" (10 mm) Drum Machine Cables |



FLOATING TRANSMITTER

Floating Transmitters are used for locating underground structures like septic tanks.

- Ideal for locating septic tanks.
- 512 Hz signal.
- Flashing LED indicates that sonde is transmitting.
- Flushable.
- Battery-powered.
- Meets FCC Class B and EN 55022 Class B requirements.

| Catalog No. | Description | Weight | |
|-------------|--------------------------------------|--------|------|
| | | lb. | kg |
| 19793 | Float Sondes (2), Plus Extra Battery | 0.4 | 0.18 |



DRAIN CLEANING

- Wide selection from a single source – "The Right Machine for Every Job".
- A legacy of innovation and quality.

| Type | No. of Models | Length (ft.) | Page |
|--------------------------------|---------------|--------------|-------------|
| Hand Tools | | | |
| Toilet/Urinal Augers | 4 | 3-6 | 13.6 |
| Grapple Hook | 1 | 6 | 13.7 |
| Flat Sewer Tape | 10 | 25-100 | 13.7 |
| Hand Spinners | 4 | 25-35 | 13.8-13.9 |
| Sink Machines | | | |
| Auto-Clean™ | 1 | 30 | 13.9 |
| K-40/K-45 | 18 | 25-35 | 13.10-13.13 |
| Drum Machines | | | |
| Up to 4" Capacity | 12 | 50-100 | 13.14-13.17 |
| Up to 6" Capacity | 3 | 50-200 | 13.18-13.19 |
| Up to 8" Capacity | 10 | 25-200 | 13.20-13.21 |
| Up to 10" Capacity | 9 | 25-250 | 13.22-13.23 |
| Open Bale Drum Machines | | | |
| Up to 6" Capacity | 1 | 100 | 13.24-13.25 |
| Sectional Machines | | | |
| Up to 4" Capacity | 16 | Up to 175 | 13.26-13.29 |
| Up to 8" Capacity | 12 | Up to 200 | 13.30-13.31 |
| Up to 10" Capacity | 11 | Up to 300 | 13.32-13.35 |
| Rodder Machines | | | |
| Up to 24" Capacity | 2 | Up to 500 | 13.36-13.37 |
| Water Jetting Machines | | | |
| Up to 4" Capacity | 4 | 25-200 | 13.38-13.39 |
| Up to 6" Capacity | 2 | 50-200 | 13.40-13.41 |
| Up to 10" Capacity | 2 | 35-300 | 13.42-13.43 |
| Pumps | | | |
| Utility | 7 | – | 13.44-13.46 |
| Pump Accessories | 4 | – | 13.46-13.47 |

HAND TOOLS



| | Page |
|-----------------|-------------|
| Augers | 13.6 |
| Grapple Hook | 13.7 |
| Flat Sewer Tape | 13.7 |
| Hand Spinners | 13.8-13.9 |

SINK MACHINES



Easily portable, compact and lightweight.

| Application | Model | Page |
|--|--------------------------|--------------|
| Bathroom/lavatory/kitchen sinks, tub/shower, urinal and laundry tub drains | Auto-Clean/ K-40/K-45 | 13.9 - 13.13 |

DRUM MACHINES



Delivers high torque to clear obstructions

- Power and torque.
- Cable-saving features.
- Superior maneuverability.

| Application | Model | Page |
|--|--------------|-------------|
| Bathroom/lavatory/kitchen sinks, tub/shower, urinal, laundry tub, roof vents and indoor floor drains | K-400 | 13.14 |
| Bathroom/lavatory/kitchen sinks, tub/shower, urinal, laundry tub, roof vents and indoor floor drains | K-3800 | 13.16 |
| House laterals/main drains/floor drains | K-6200 | 13.18 |
| Laterals, main lines, commercial lines | K-750 | 13.20 |
| | K-7500 | 13.24 |
| | K-750R | 13.22 |

SECTIONAL MACHINES



High-speed cutting action to drill through obstructions.

- Power and speed with cable control.
- Lightweight and portable.

| Line Size | Application | Model | Page |
|-----------|--|----------|-------|
| ¾" to 4" | Bathroom/lavatory/kitchen sinks, tub/shower, urinal, laundry tub, roof vents and indoor floor drains | K-50 | 13.26 |
| 1¼" to 4" | Sink lines, roof vents and floor drains | K-60SP | 13.28 |
| 2" to 8" | Floor/secondary lines, laterals and main lines | K-1500 | 13.30 |
| 2" to 10" | Laterals and main lines, commercial lines | K-1500SP | 13.32 |
| 2" to 10" | Laterals and main lines, commercial lines – gasoline engine powered for remote locations | K-1500G | 13.34 |

RODDER MACHINES



Designed specifically for larger diameter lines.

| Line Size | Application | Model | Page |
|-----------|---|--------|-------|
| 8" to 24" | Straight main work in municipalities, universities, institutions and industry | K-1000 | 13.36 |

WATER JETTERS



Water jetting machines are ideal for clearing grease, sludge or soap-clogged lines.

| Line Size | Application | Model | Page |
|-----------|--|--------------------|-------|
| 1¼" to 4" | Sink lines/floor/secondary lines | KJ-1350 KJ-1750 | 13.38 |
| 1¼" to 6" | Sink lines/floor/secondary lines/laterals | KJ-2200 | 13.40 |
| 2" to 10" | Sink lines/floor/secondary lines/laterals/main lines | KJ-3100 | 13.42 |





PUMPS



High quality, performance and dependability.







| Type | Features | Page |
|-------------|-------------------------------------|-------|
| Utility | Corrosion-resistant dewatering duty | 13.44 |
| Utility | Semi-trash pumps | 13.46 |
| Accessories | Check valves and water sensor | 13.46 |

For Drain Guns, Sink Drums, and Small Line Sectional Machines









| | Model | Length | Typical Application | Characteristics | Machines |
|-------------|---|-------------------|--|---|--|
| 5/16" (8mm) |  Bulb Auger C-1 C-21 | 25' 50' | Drain Lines 3/4" to 1 1/2". Kitchen Sinks, Lavatory Sinks, Bathtub Drains, Drinking Fountains and Urinals. | Hollow core cables that provide maximum flexibility for severe bends and "P" Traps. | K-25/K-26 (25' only) K-45 K-40 K-50* |
| |  Drop Head C-2 C-22 | 25' 50' | Drain Lines 3/4" to 1 1/2". Drop Head leads into down drain pipes, especially good for back-to-back mounted fixtures and severe bends. | | |
| |  Inner Core w/ Bulb Auger C-11C C-131C | 25' 35' | Drain Lines 1 1/4" to 2". Kitchen Sinks, Lavatory Sinks, Slop Sinks and Laundry Lines. | Inner core cables that provide good flexibility while resisting kinking. | K-25/K-26 (25' only) K-45, K-40 K-3800, K-50* |
| |  Inner Core w/ Drop Head C-21C C-231C | 25' 35' | Drop Head leads into down drain pipes, especially good for back-to-back mounted fixtures and severe bends. | | |
| 3/8" (10mm) |  Male Coupling C-4 C-6 C-61C | 25' 35' 35' | Drain Lines 1 1/4" to 2 1/2". Kitchen Sinks, Lavatory Sinks, Slop Sinks, and Disposal Waste Lines. | Flexible, yet tough 3/8" cable most commonly used after traps have been removed. C-61C slightly stiffer than C-6. | K-45 K-40 K-50* |
| |  Bulb Auger C-5 | 35' | Drain Lines 1 1/4" to 2 1/2". Kitchen Sinks, Lavatory Sinks, Slop Sinks, and Disposal Waste Lines. | | |

*See Page 12.25 for Proper Adapter or Sink Drum.











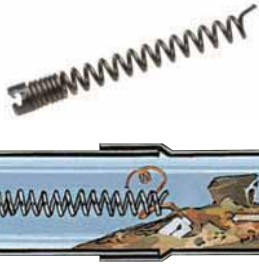
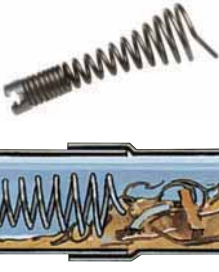
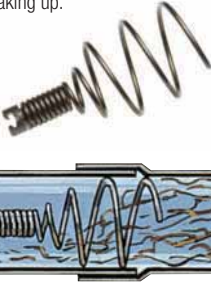

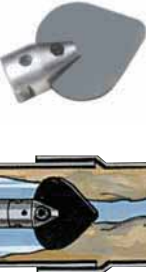
For Drum Machines

| | Model | Length | Typical Application | Characteristics | Machines |
|-------------|--|---------------------------|---|--|-----------------|
| 3/8" (10mm) |  w/Inner Core C-31, C-31IW C-32, C-32IW C-33, C-33IW | 50' 75' 100' | Drain Lines 1 1/2" to 2 1/2". Kitchen Sinks, Lavatory Sinks, Slop Sinks and Laundry Stacks. | Good flexibility. As torque builds, outer spring tightens on wire core causing cable to stiffen and transfer greater torque to cutter. | K-400 K-3800 |
| |  w/Inner Core C-44, C-44IW C-45, C-45IW C-46 | 50' 75' 90' | Drain Lines 2" to 4". Laundry Stacks, Roof Vents and Indoor Floor Drains. | | |
| |  w/Inner Core C-25, C-25HD C-26, C-26HD C-27, C-27HD C-24, C-24HD | 25' 50' 75' 100' | Drain Lines 3" to 6". Floor Drains, Vents, and Laterals. | | |
| 5/8" (16mm) |  w/Hollow Core C-27HC C-24HC | 75' 100' | Drain Lines 3" to 6". Floor Drains, Vents, and Laterals. | Hollow core cable is lighter in weight & more flexible. Helps operator negotiate difficult traps & bends in large lines. | K-750 K-7500 |
| |  w/Inner Core C-28 C-29 C-75 C-100 | 25' 50' 75' 100' | Drain Lines 4" to 10". Main Lines including Laterals. | | |
| 3/4" (20mm) |  w/Inner Core C-75HC C-100HC | 75' 100' | Drain Lines 4" to 6". Main Lines including Laterals. | Hollow core cable is lighter in weight and more flexible. Helps operator negotiate difficult traps and bends in large lines. | K-750 K-7500 |
| |  w/Inner Core | | | | |

For Sectional Machines

| | Model | Length | Typical Application | Characteristics | Machines |
|---------------|--|--------|---|---|----------------------|
| 5/8" (16mm) |  C-7 | 7 1/2' | 2" and 3" Floor Drains. | Tight wind cable providing good rigidity in a hollow core cable. Not for tree roots. | K-50, K-60SP |
| |  C-8 | 7 1/2' | Drain Lines 1 1/4" to 2". Ideal for proper cleaning of small lines. | Open wind cable that is more flexible than C-7. Open wind acts as an auger to thoroughly remove blockages in small lines. | |
| |  C-9 | 10' | Drain Lines 2" to 4". Ideal for Floor Drains and Stacks. | Heavy-Duty open wind cable ideal for long runs in indoor lines. | |
| 7/8" (22MM) |  C-10 | 15' | Drain Lines 2" to 4". Rooftop Vent Stacks. | Standard all-purpose open wind. Excellent flexibility. | K-60SP K-1500A/B* |
| 1 1/4" (32mm) |  C-11 | 15' | Drain Lines 3" to 8". Good for all around work. Easily negotiates 4" Traps. | Standard all-purpose open wind with 3/8" pitch. Flexible, yet rigid enough to do fast, tough root cutting. | K-1500A/B/& SP |
| |  C-12 | 15' | Drain Lines 4" to 10". Do not use through 4" "P" Traps. | Extra-heavy-duty open wind with 3/8" pitch. Designed for 4" to 10" long runs. | |
| |  C-14 | 15' | Drain Lines 3" to 10". Do not use through 4" "P" Traps. | Heavy-duty open wind with 1/2" pitch. Especially good For 4" cleanout or 8" elbow entering in 4" to 10" line. | |
| |  C-15 | 15' | Drain Lines 3" to 6". Ideal for 4" Traps. | Extra-flexible open wind with 1/2" pitch. Lighter than C-11, slightly stiffer. | K-1500A/B |

*See Page 12.29 for Proper Jawset.

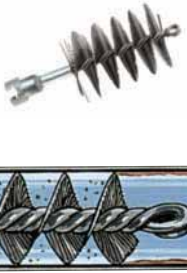
| | | | |
|--|---|--|--|
| <p>Drop Head Auger For cleaning back to back mounted fixtures e.g., sinks where cable needs to be led into down pipe.</p>  | <p>Straight Auger For use in exploring and breaking up stoppages or returning sample to surface to determine correct tool.</p>  | <p>Funnel Auger For use as second tool in line. Breaks up remains of stoppage left by straight auger.</p>  | <p>Hook Auger For heavy and dense root stoppages in pipes that require hooking and breaking up.</p>  |
| <p>Retrieving Auger For searching for cable which is broken or lost in line.</p>  | <p>Spade Cutter For following up after augers have been used and to open up floor drains.</p>  | <p>Four Blade Saw Tooth Cutter For blockages caused by hardened, glazed material such as chemical deposits.</p>  | <p>Grease Cutter For lines which have become badly greased with detergents and have to be opened.</p>  |
| <p>Spiral Saw Tooth Cutter For clearing any stoppage, roots, rags, sticks, etc.</p>  | <p>Saw Tooth Cutter For cleaning lines blocked heavily with roots. Unique design permits cutter to be removed from damaged pipe without locking.</p>  | <p>Spiral Bar Cutter For main sewers blocked by roots, leaf debris, sticks, sawdust, cloth, and sacking.</p>  | <p>Sharktooth Cutter For use in cleaning pipes of general material clinging to pipe walls.</p>  |
| <p>Grease "C" Cutter For grease blockage in lines leading from garbage disposal unit or waste pipe.</p>  | <p>Expanding Finish Cutters For final removal of material adhering to walls and certain roots of fibrous nature.</p>  | <p>Chain Knocker For use when vigorous action is required for cleaning of scale in pipes and boiler tubes.</p>  | <p>Flue Brush For use for finish cleaning required of boiler tubes and heat exchangers.</p>  |

(TOOLTIP)

Always start with a straight auger to and determine what you are trying to clean. Then chose the correct cutter to clear the drain.

Toilet/Urinal Augers



K-1 COMBINATION AUGER

- The K-1 Combination Auger provides an all-in-one solution for removing blockages from urinals and shower drains.
- Dual Power Operation - provides additional power necessary for removing tough obstructions.
- Telescoping Design - provides additional cable length needed to remove obstructions further down the line.
- "C" Cutter Head - ideal for breaking up hard blockages.
- Left Hand Wound Cable - strengthens cable and prevents kinking.

SPECIFICATIONS

- Pipe Sizes Up to 2" (50 mm)
- Cable Length – 4 ft (1.2 m)
- Cable Diameter – 3/8" (10 mm)
- Operation – Manual or Drill Powered
- Applications – Urinals & Shower Drains
- Cutter Head Type – "C" Cutter

| Catalog No. | Model No. | Description | Weight | |
|-------------|-----------|-----------------------|--------|-----|
| | | | lb. | kg |
| 46683 | K-1 | K-1 Combination Auger | 5 | 2.3 |



K-3 AND K-6 TOILET AUGERS

- High quality tools in 3' (1 m) and 6' (2 m) lengths provide fast and safe clearing of toilet obstructions.
- Vinyl guard protects porcelain.
- New durable, kink-resistant, 1/2" (12.7 mm) compression-wrapped Inner Core Cable.
- Large, ergonomically designed handles.
- Negotiate water-conserving toilets.

| Catalog No. | Model No. | Description | Weight | | Replac. Cables |
|-------------|-----------|--------------------------------------|--------|-----|----------------|
| | | | lb. | kg | |
| 59787 | K-3 | 3' (1 m) Toilet Auger with Bulb Head | 4 1/2 | 1.9 | - |
| 59797 | K-6 | 6' (2 m) Toilet Auger with Bulb Head | 5 1/2 | 2.5 | 60362 |
| 59802 | K-6 DH | 6' Toilet Auger with Drop Head | | | 60367 |



Grappler Hook



K-5 GRAPPLER HOOK

- Retrieves rocks, tools and other objects.
- Extends your reach 6' (2 m) for even the deepest traps.

| Catalog No. | Model No. | Description | Weight | |
|-------------|-----------|------------------|--------|-----|
| | | | lb. | kg |
| 59190 | K-5 | Grappler Hook | 5 | 2.3 |
| 61820 | | Replacement Jaws | 0 | 0.2 |

Sewer Tape



ONE-PIECE FLAT SEWER TAPE

- Sizes and lengths for use on sewer and drain lines through 8" (200 mm) in diameter and up to 100' (30,4 m) in length.
- Carrier included with all except 25' (7,6 m) model.
- All models have a hand grip and a spear point at one end and roller ball at the other.

| Catalog No. | Model No. | Width | | Thickness | | Length | | Capacity | | Weight lb. | Weight kg |
|-------------|-----------|-------|----|-----------|----|--------|------|-------------|-----------|------------|-----------|
| | | in. | mm | in. | mm | ft. | m | in. | mm | | |
| 62530 | E-2724 | 1/2 | 12 | 1/16 | 2 | 25 | 7.6 | 3/4 - 1 1/2 | 20 - 40 | 3 | 1.4 |
| 62535 | E-2725 | | | | | 50 | 15.2 | | | 6 | 2.7 |
| 62540 | E-2726 | | | | | 75 | 22.8 | | | 9 | 4.1 |
| 62545 | E-2727 | | | | | 100 | 30.4 | | | 12 | 5.4 |
| 62555 | E-2729 | 3/4 | 20 | 1/8 | 3 | 50 | 15.2 | 2 - 4 | 50 - 110 | 8 | 3.6 |
| 62565 | E-2731 | | | | | 100 | 30.4 | | | 18 | 8.2 |
| 62595 | E-2737 | | | | | 50 | 15.2 | 16 | 7.3 | | |
| 62605 | E-2739 | | | | | 100 | 30.4 | 34 | 15.4 | | |
| 62615 | E-2741 | 1 | 25 | 1/8 | 3 | 50 | 15.2 | 4 - 6 | 110 - 150 | 22 | 10.0 |
| 62625 | E-2743 | | | | | 100 | 30.4 | | | 45 | 20.4 |

Hand Spinners



Standard Equipment

| Catalog No. Model No. | 58890 K-25-BP | 58895 K-25-DH |
|--|------------------|------------------|
| 56782 - 5/16" (8 mm) x 25' (7.6 m) Inner Core with Bulb Auger | • | |
| 56787 - 5/16" (8 mm) x 25' (7.6 m) Inner Core with Drop Head Auger | | • |

K-25 HAND SPINNER

- 3/4" to 1 1/2" (20 to 40 mm) Drain Lines
- The professional's choice for many years, the Model K-25 Hand Spinner offers premium quality. It's the ideal tool for the user who demands the best.
- Premium-quality, precision machined, 3-jaw chuck firmly secures cable. Releases cable with the flick-of-the-wrist.
- Cast aluminum ribbed hand grip won't slip in your hand.
- Rotary molded plastic drum won't dent or rust – cleans easily.
- Available in bulb head and drop head models. 5/16" (8 mm) x 25' (7,6 m) vinyl-wrapped inner core, kink-resistant cables.
- 5/16" x 25' (8 mm x 7.6 m) vinyl-wrapped inner core, kink-resistant cables.
- Balanced for comfortable operation.
- Drum Capacity: 5/16" x 25' (8 mm x 7.6 m).
- Works through traps and bends in sinks, tubs, drinking fountains, lavatories, urinals or vent pipes.

| Catalog No. | Model No. | Description | Cable Diameter | | Length | | Weight | |
|-------------|-----------|--|----------------|----|--------|-----|--------|-----|
| | | | in. | mm | ft. | m | lb. | kg |
| 58890 | K-25-BP | Hand Spinner with C-11C Bulb Auger Cable | 5/16 | 8 | 25 | 7.6 | 8 | 3.6 |
| 58895 | K-25-DH | Hand Spinner with C-21C Drop Head Cable | 5/16 | 8 | 25 | 7.6 | | |



Standard Equipment

| Catalog No. Model No. | 59812 K-26 |
|--|---------------|
| 62225 - 5/16" (8 mm) x 25' (7.6 m) with Bulb Auger | • |

K-26 HAND SPINNER

- 3/4" to 1 1/2" (19 to 40 mm) Drain Lines
- Ideal for users seeking excellent performance and value.
- Slip-resistant collet chuck that grips cable with the flick-of-the-wrist.
- 5/16" x 25' (8 mm x 7.6 m) hollow core cable with bulb head auger.
- Rotary molded plastic drum that won't rust or dent – cleans easily.
- Open drum design that permits access to cable and allows application of RIDGID® Cable Rust Inhibitor.

| Catalog No. | Model No. | Description | Cable Diameter | | Length | | Weight | |
|-------------|-----------|--------------------------------------|----------------|----|--------|-----|--------|-----|
| | | | in. | mm | ft. | m | lb. | kg |
| 59812 | K-26 | Hand Spinner with C1 Bulb Head Cable | 5/16 | 8 | 25 | 7.6 | 6 | 2.7 |



POWER SPIN WITH AUTOFEED®

- 1/2" to 1 1/2" (12.6 to 40 mm) Drain Lines.
- Pull trigger and turn handle, or add any variable speed (left / right) chuck drill machine for extra power.
- Cable self-feeds down drain.
- No mess. Hands don't touch cable.
- Equipped with 1/4" x 25" (6.3 mm x 7.6 m) MAXCORE® cable with bulb auger.

| Catalog No. | Model No. | Description | Diameter | | Length | | Weight | |
|-------------|------------|----------------------------------|----------|----|--------|---|--------|-----|
| | | | in. | mm | ft. | m | lb. | kg |
| 41408 | Power Spin | Hand Spinner with Straight Auger | 1/4 | 6 | 25 | 8 | 5 | 2.2 |
| 42163 | Cable | MAXCORE Replacement Cable | 1/4 | 6 | 25 | 8 | 3 | 1.4 |

Hand Spinners



KWIK-SPIN® HAND SPINNER WITH AUTOFEED®

- 1/2" to 1 1/2" (12.6 to 40 mm) Drain Lines
- For light-duty cleaning.
- Comfortable hand grip eases effort.
- Equipped with 1/4" x 25' (6.3 mm x 7.6 m) MAXCORE® cable with straight auger.
- Two-way AUTOFEED control keeps hands and work area clean.

| Catalog No. | Model No. | Description | Diameter | | Length | | Weight | |
|-------------|-----------|------------------------------|----------|-----|--------|-----|--------|-----|
| | | | in. | mm | ft. | m | lb. | kg |
| 41348 | Kwik-Spin | Hand Spinner with Bulb Auger | 1/4 | 6.3 | 25 | 7.6 | 3.5 | 1.6 |

Sink Machines



AUTO-CLEAN™/K-30 SINK MACHINE

- 3/4" to 1 1/2" (20 mm to 12.6 mm) Drain Lines
- Clean – Cable contained inside guide hose to minimize cleanup of hands, work areas and fixtures.
- Immediate Results – Strong, durable MAXCORE® 50 cable for tough blockages.
- AUTOFEED® Control – Conveniently powers cable down drain and through blockages. Aluminum paddles advance cable 20% faster.
- MAXCORE® 50 Cable – Includes 1/4" x 30' (6 mm x 9 m) Inner core cable for increased strength and longer life. Provides 50% more cleaning power for tough blockages.
- Powerful Motor – Single phase, AC 1.1 Amp, 60Hz, 450 RPM, CSA approved.

| Catalog No. | Model No. | Description | Cable Diameter | | Cable Length | | Weight | |
|-------------|-----------|------------------------------|----------------|----|--------------|---|--------|-----|
| | | | in. | mm | ft. | m | lb. | kg |
| 34963 | K-30 | Sink Machine | 1/4 | 6 | 30 | 9 | 10 | 4.5 |
| 34893 | | 1/4" - 30' Replacement Cable | 1/4 | 6 | 30 | 9 | 1/2 | 0.6 |

Sink Machines



K-40 SINK MACHINE

- 3/4" to 2 1/2" (20 mm to 75 mm) Drain Lines
- The Model K-40 Sink Machine is ideal for cleaning small secondary drain lines.
- 1/4" (6 mm) cables best for 3/4" to 1 1/2" (20 mm to 40 mm) lines.
- 5/16" (8 mm) cables best for 3/4" to 1 1/2" (20 mm to 40 mm) lines.
- 3/8" (10 mm) cables best for 1 1/4" to 2 1/2" (40 mm to 75 mm) lines.
- The K-40 sits flat on the floor or countertop and also tips onto its back for easy access to sink drains and bathtubs full of water. It practically eliminates job site cleanup thanks to the patented guide hose two-way AUTOFEED® control. It completely contains the rotating cable and eliminates any waste water splashing or spraying.
- 175-watt induction motor quietly delivers enough torque to clear even the toughest blockages.
- Premium-quality, compression-wound inner core cable combines strength and flexibility to resist kinking.
- Two-piece "twist lock" drum housing will not dent or corrode and allows easy access to the inner drum and cable.
- Special inner drum design virtually eliminates cable flip-over inside the drum and drum leakage.
- Two-way AUTOFEED control advances and retrieves the drain cleaning cable with a simple push of a lever keeping you and the work area clean.
- Includes RIDGID® drain cleaning gloves and operator's manual.

| Catalog No. | Model No. | Description | Voltage | | | Weight | |
|-------------|---------------|--|---------|-----|------|--------|--|
| | | | V | lb. | kg | | |
| 71702 | K-40 | Machine with: C-131C, 5/16" x 35' (8 mm x 10.7 m) Cable with Inner Drum | 115 | 29 | 13.0 | | |
| 71722 | K-40AF | Machine with: AUTOFEED, Guide Hose, Mounting Bracket, C-131C SB, 5/16" x 35' (8 mm x 10.7 m) Speed Bump Cable with Inner Drum | 115 | 33 | 15.0 | | |
| 71732 | | | 230 | | | | |
| 78347 | K-40B AF | Battery Powered Machine with: AUTOFEED, Guide Hose, Mounting Bracket, C-131C SB, 5/16" x 35" (8 mm x 10.7 m) Cable with Inner Drum, (2) 14.4V Battery Packs, 14.4V Battery Charger | - | 24 | 11.0 | | |
| 71717 | K-40 AF 110 V | Machine with: AUTOFEED, Guide Hose, Mounting Bracket, C-131C SB, 5/16" x 35' (8 mm x 10.7 m) Speed Bump Cable with Inner Drum | - | - | - | | |

Standard Equipment

| Catalog No. Model No. | 71702 K-40 | 71722 K-40AF | 71727 K-40AF | 71732 K-40B AF | 78347 K-40AF 110V |
|--|---------------|-----------------|-----------------|-------------------|-------------------------|
| 56792 - 5/16" (8 mm) x 35' (10.7 m) Inner Core with Bulb Auger | • | | • | | |
| 95847 - 5/16" (8 mm) x 35' (10.7m) Inner Core Speed Bump with Bulb Auger | | • | | • | • |



Cables

| | Catalog No. | Model No. | Description | Weight | |
|--|-------------|-----------|---|--------|-----|
| | | | | lb. | kg |
| | 50647 | S-1 | 1/4" (6 mm) x 15' (4,6 m) with Funnel Auger | 2 1/4 | 1.0 |
| | 50652 | S-2 | 1/4" (6 mm) x 25' (7,6 m) with Funnel Auger | 3 1/2 | 2.0 |
| | 50657 | S-3 | 1/4" (6 mm) x 35' (10,7 m) with Funnel Auger | 5 | |
| | 62225 | C-1 | 5/16" (8 mm) x 25' (7,6 m) with Bulb Auger | 3 1/2 | 3.0 |
| | 56782 | C-11C | 5/16" (8 mm) x 25' (7,6 m) Inner Core with Bulb Auger | 4 | |
| | 89400 | C-21 | 5/16" (8 mm) x 50' (15,2 m) with Bulb Auger | 7 | 2.0 |
| | 56792 | C-131C | 5/16" x 35' (8 mm x 10,7 m) Inner Core with Bulb Auger | 5 1/2 | |
| | 95847 | C-131CSB | 5/16" x 35' (8 mm x 10,7 m) Inner Core Speed Bump with Bulb Auger | 3 1/2 | 3.0 |
| | 62235 | C-2 | 5/16" (8 mm) x 25' (7,6 m) with Drop Head Auger | 4 | |
| | 56787 | C-21C | 5/16" (8 mm) x 25' (7,6 m) Inner Core with Drop Head Auger | 7 | 2.0 |
| | 89405 | C-22 | 5/16" (8 mm) x 50' (15,2 m) with Drop Head Auger | 5 1/2 | |
| | 56797 | C-231C | 5/16" (8 mm) x 35' (10,7 m) Inner Core with Drop Head Auger | 4 1/2 | 4.0 |
| | 62245 | C-4 | 3/8" (10mm) x 25' (7,6 m) with Male Coupling | 8 1/4 | |
| | 62250 | C-5 | 3/8" (10mm) x 35' (10,7 m) with Bulb Auger | 8 1/2 | 4.0 |
| | 62260 | C-6 | 3/8" (10 mm) x 35' (10,7 m) with Male Coupling | 8 1/2 | |
| | 96037 | C-61C | 3/8" (10mm) x 35' (10,7 m) Inner Core with Male Coupling | | |

Tools

| | Catalog No. | Model No. | Description | Replac. Blade(s) |
|--|-------------|-----------|---|------------------|
| | 62990 | T-201 | Straight Auger, 5" (125 mm) Long | |
| | 62995 | T-202 | Bulb Auger, 1 1/8" (29 mm) O.D. | - |
| | 63000 | T-203 | Bulb Auger 7/8" (22 mm) O.D. | |
| | 54837 | T-204 | "C" Cutter 1" (25 mm) | 54832 |
| | 63005 | T-205 | "C" Cutter, 1 3/8" (35 mm) | 97835 |
| | 63010 | T-206 | Funnel Auger, 3" (80 mm) Long | - |
| | 63030 | T-210 | Spade Cutter, 1" (25 mm) | 97905 |
| | 63035 | T-211 | Spade Cutter, 1 3/8" (35 mm) | 97825 |
| | 63040 | T-212 | Spade Cutter, 1 3/4" (45 mm) | 92850 |
| | 63045 | T-213 | 4-Blade Cutter, 1" (25 mm) | 97795 |
| | 63050 | T-214 | 4-Blade Cutter, 1 3/8" (35 mm) | 97910 |
| | 63055 | T-215 | 4-Blade Cutter, 1 3/4" (45 mm) | 97915 |
| | 63065 | T-217 | Drop Head Auger, 4" (110 mm) Long | |
| | 55457 | T-225 | Retrieving Auger | - |
| | 48482 | T-250 | Tool Set includes: T-203, T-205, T-210, T-217, A-13 | |
| | 52812 | T-230 | H-D "C" Cutter, 2" (50 mm) | 92815 |
| | 52817 | T-231 | H-D "C" Cutter, 2 1/2" (65 mm) | 92820 |
| | 52822 | T-232 | H-D "C" Cutter, 3" (80 mm) | 92835 |
| | 59230 | A-13 | 3/8" Cable Pin Key | - |

Accessories

| | Catalog No. | Model No. | Description |
|--|-------------|-----------|--|
| | 26558 | A-40AF | AUTOFEED Assembly & Guide Hose for K-40 Includes Mounting Bracket |
| | 23913 | A-39AF | Replacement AUTOFEED Cartridge |
| | 71757 | A-40G | A-40G Guide Hose Assembly |
| | 72702 | A-40B | Mounting Bracket |
| | 83407 | | 14.4V Battery Pack |
| | 83417 | | 115V Charger |
| | 71847 | | Cable Torque Arm |
| | 68917 | | Drum Liner |
| | 76597 | | Top Roller Bearing Housing Assy. |
| | 76817 | | C-6 Cable Kit incl. Inner Drum, C-6 Cable Torque Arm, T-250 Tool Set |
| | 98072 | | C-61C Cable Kit including: Inner Drum, C-61C Cable, Torque Arm, T-250 Tool Set |
| | 41937 | | RIDGID® Leather Drain Cleaning Gloves |
| | 70032 | | RIDGID® PVC Drain Cleaning Gloves |

Sink Machines



K-45 SINK MACHINE

- 3/4" to 2 1/2" (20 mm to 75 mm) Drain Lines
- 1/4" (6 mm) cables best for 3/4" to 1 1/2" (20 mm to 40 mm) lines.
- 5/16" (8 mm) cables best for 3/4" to 1 1/2" (20 mm to 40 mm) lines.
- 3/8" (10 mm) cables best for 1 1/4" to 2 1/2" (30 mm to 75 mm) lines.
- Excellent for small line cleaning. Opens clogged lavatory, sink lines, urinals and tub or shower drains.
- Advanced two-way AUTOFEED® control keeps hands and work area clean – advances & retrieves cable with push of a lever.
- Manual version has a slide-action chuck for quick locking/releasing of cable (Not available in Europe).
- Lightweight, easy-to-use, no setup required.
- Variable speed power unit rotates cable 0-600 RPMs.
- Two-piece twist lock canister with interchangeable inner drum – Makes cable change-out simple; easy to match the right cable for the job.
- Inner drum prevents water leaks and greatly reduces cable flip-over inside the drum.
- Drums won't rust or dent-ever.
- Drum Capacity: 50' of 5/16" (15 m of 8 mm) or 35' of 3/8" (11 m of 10 mm).
- Includes RIDGID® drain cleaning gloves and operator's manual.
- Approved by CSA to CSA and UL Standards (115V only).

INNER CORE CABLES

(MODELS C-1IC, C-6IC, C-13IC, C-2IC, C-23IC)

- Vinyl-wrapped inner core to prevent core from rusting to spring – enhances cable life.
- Compression wound for strength.
- Resists kinking and negotiates tough bends and traps.
- Provides good flexibility and cleaning power to the cable end.

| | Catalog No. | Model No. | Description | Voltage | Weight | |
|--------|-------------|-----------|---|---------|--------|------|
| | | | | V | lb. | kg |
| K-45AF | 35473 | K-45AF | K-45AF Machine with: - C-1IC, 5/16" x 25' (8 mm x 7.6 m) Inner Core Cable with Inner Drum | 115 | 11 | 5.0 |
| | 36033 | | Machine with: - C-1IC, 5/16" x 25' (8 mm x 7.6 m) Inner Core Cable with Inner Drum | 230 | 13.8 | 6.5 |
| | 35998 | K-45AF-1 | Same as Model No. K-45AF plus: C-6429 Carrying Case | 115 | 27 | 12.2 |
| | 36038 | | | 230 | | |
| | 36003 | K-45AF-5 | K-45AF Machine with: - C-1IC, 5/16" x 25' (8 mm x 7.6 m) Inner Core Cable with Inner Drum - C-6, 3/8" x 35' (10 mm x 10.7 m) Cable with Inner Drum - T-250, Five -Piece Tool Set for 3/8" (10 mm) Cable - C-6429 Carrying Case | 115 | 34 | 15.4 |
| | 36043 | | Machine with: - C-1IC, 5/16" x 25' (8 mm x 7.6 m) Inner Core Cable with Inner Drum - C-6, 3/8" (10 mm) x 25' (10.7 m) Cable with Inner Drum - T-250, Five -Piece Tool Set for 3/8" (10 mm) Cable - C-6429 Carrying Case | 230 | | |
| | 36008 | K-45AF-7 | K-45AF Machine with: - C-1IC, 5/16" x 25' (8 mm x 7.6 m) Inner Core Cable w/Inner Drum - C-6, 3/8" x 35' (10 mm x 10.7 m) Cable with Inner Drum - C-21, 5/16" x 50' (8 mm x 15.2 m) Cable with Inner Drum - T-250, Five -Piece Tool Set for 3/8" (10 mm) Cable - C-6429 Carrying Case | 115 | 42 | 19.0 |
| K-45 | 36018 | K-45 | K-45 Machine with: - C-1IC, 5/16" x 25' (8 mm x 7.6 m) Inner Core Cable with Inner Drum | 115 | 11 | 5.0 |
| | 36048 | | | 230 | | |
| | 36013 | K-45-1 | Same as Model No. K-45 plus: C-6429 Carrying Case | 115 | 27 | 12.2 |
| | 36053 | | | 230 | | |
| | 36023 | K-45-5 | K-45 Machine with: - C-1IC, 5/16" x 25' (8 mm x 7.6 m) Inner Core Cable with Inner Drum - C-6, 3/8" x 35' (10 mm x 10.7 m) Cable with Inner Drum - T-250, Five -Piece Tool Set for 3/8" (10 mm) Cable - C-6429 Carrying Case | 115 | 34 | 15.4 |
| | 36058 | K-45 | K-45AF Machine with: - C-1IC, 5/16" x 25' (8 mm x 7.6 m) Inner Core Cable with Inner Drum - C-6, 3/8" x 35' (10 mm x 10.7 m) Cable with Inner Drum - T-250, Five -Piece Tool Set for 3/8" (10 mm) Cable - C-6429 Carrying Case | 230 | | |
| | 36028 | K-45-7 | K-45AF Machine with: - C-1IC, 5/16" x 25' (8 mm x 7.6 m) Inner Core Cable with Inner Drum - C-6, 3/8" x 35' (10 mm x 10.7 m) Cable Inner Drum - C-21, 5/16" x 50' (8 mm x 15.2 m) Cable with Inner Drum - T-250, Five -Piece Tool Set for 3/8" (10 mm) Cable - C-6429 Carrying Case | 115 | 42 | 19.0 |

Standard Equipment

| Catalog No. Model No. | 35473 K-45AF | 36033 K-45AF | 35998 K-45AF-1 | 36038 K-45AF-1 | 36003 K-45AF-5 | 36043 K-45AF-5 | 36008 K-45AF-7 | 36018 K-45 | 36048 K-45 | 36013 K-45-1 | 36053 - | 36023 K-45-5 | 36058 K-45 | 36028 K-45AF-7 |
|---|-----------------|-----------------|-------------------|-------------------|-------------------|-------------------|-------------------|---------------|---------------|-----------------|------------|-----------------|---------------|-------------------|
| 56782 - 5/16" (8 mm) x 25' (7.6 m) Inner Core with Bulb Auger | • | • | • | • | • | • | • | • | • | • | • | • | • | • |
| 89410 - Carrying Case | | | • | • | • | • | • | | | • | • | • | • | • |
| 48482 - Tool Set includes: T-203, T-205, T-210, T-217, A-13 | | | | | • | • | • | | | | | • | • | • |
| 62260 - 3/8" (10 mm) x 35' (10.7 m) with Male Coupling | | | | | • | • | • | | | | | • | • | • |
| 89400 - 5/16" (8 mm) x 50' (15.2 m) with Bulb Auger | | | | | | | • | | | | | | | • |

Cables



| | Catalog No. | Model No. | Description | Weight | |
|------------|-------------|-----------|---|--------|-----|
| | | | | lb. | kg |
| 1/4"-6 mm | 50647 | S-1 | 1/4" (6 mm) x 15' (4,6 m) with Funnel Auger | 2 1/4 | 1.0 |
| | 50652 | S-2 | 1/4" (6 mm) x 25' (7,6 m) with Funnel Auger | 3 1/2 | 1.6 |
| | 50657 | S-3 | 1/4" (6 mm) x 35' (10,7 m) with Funnel Auger | 5 | 2.2 |
| 5/16"-8 mm | 62225 | C-1 | 5/16" (8 mm) x 25' (7.6 m) with Bulb Auger | 3 1/2 | 1.6 |
| | 56782 | C-11C | 5/16" (8 mm) x 25' (7.6 m) Inner Core with Bulb Auger | 4 | 1.8 |
| | 89400 | C-21 | 5/16" (8 mm) x 50' (15,2 m) with Bulb Auger | 7 | 3.2 |
| | 56792 | C-131C | 5/16" x 35' (8 mm x 10.7 m) Inner Core with Bulb Auger | 5 1/2 | 2.5 |
| | 62235 | C-2 | 5/16" (8 mm) x 25' (7,6 m) with Drop Head Auger | 3 1/2 | 1.6 |
| | 56787 | C-21C | 5/16" (8 mm) x 25' (7.6 m) Inner Core with Drop Head Auger | 4 | 1.8 |
| | 89405 | C-22 | 5/16" (8 mm) x 50' (15,2 m) with Drop Head Auger | 7 | 3.2 |
| | 56797 | C-231C | 5/16" (8 mm) x 35' (10,7 m) Inner Core with Drop Head Auger | 5 1/2 | 2.5 |
| 3/8"-10 mm | 62245 | C-4 | 3/8" (10mm) x 25' (7,6 m) with Male Coupling | 4 1/2 | 2.0 |
| | 62250 | C-5 | 3/8" (10mm) x 35' (10,7 m) with Bulb Auger | 8 1/4 | 3.8 |
| | 62260 | C-6 | 3/8" (10 mm) x 35' (10,7 m) with Male Coupling | 8 1/2 | 4.0 |
| | 96037 | C-61C | 3/8" (10mm) x 35' (10,7 m) Inner Core with Male Coupling | 8 1/2 | 4.0 |

Tools – Fits C-4, C-6 and C-61C Cables

| | Catalog No. | Model No. | Description | Replac. Blade(s) |
|--|-------------|-----------|---|------------------|
| | 62990 | T-201 | Straight Auger, 5" (125 mm) Long | |
| | 62995 | T-202 | Bulb Auger, 1 1/8" (29 mm) O.D. | - |
| | 63000 | T-203 | Bulb Auger 7/8" (22 mm) O.D. | |
| | 54837 | T-204 | "C" Cutter 1" (25 mm) | 54832 |
| | 63005 | T-205 | "C" Cutter, 1 3/8" (35 mm) | 97835 |
| | 63010 | T-206 | Funnel Auger, 3" (80 mm) Long | - |
| | 63030 | T-210 | Spade Cutter, 1" (25 mm) | 97905 |
| | 63035 | T-211 | Spade Cutter, 1 3/8" (35 mm) | 97825 |
| | 63040 | T-212 | Spade Cutter, 1 3/4" (45 mm) | 92850 |
| | 63045 | T-213 | 4-Blade Cutter, 1" (25 mm) | 97795 |
| | 63050 | T-214 | 4-Blade Cutter, 1 3/8" (35 mm) | 97910 |
| | 63055 | T-215 | 4-Blade Cutter, 1 3/4" (45 mm) | 97915 |
| | 63065 | T-217 | Drop Head Auger, 4" (110 mm) Long | |
| | 55457 | T-225 | Retrieving Auger | - |
| | 52812 | T-230 | H-D "C" Cutter, 2" (50 mm) | 92815 |
| | 52817 | T-231 | H-D "C" Cutter, 2 1/2" (65 mm) | 92820 |
| | 52822 | T-232 | H-D "C" Cutter, 3" (80 mm) | 92835 |
| | 48482 | T-250 | Tool Set includes: T-203, T-205, T-210, T-217, A-13 | |

Accessories

| Catalog No. | Model No. | Description |
|-------------|-----------|--|
| 68917 | - | Drum Liner |
| 89410 | C-6429 | Carrying Case |
| 76817 | - | C-6 Cable Kit incl. Inner Drum, C-6 Cable Torque Arm, T-250 Tool Set |
| 98072 | - | C-61C Cable Kit including: Inner Drum, C-61C Cable, Torque Arm, T-250 Tool Set |
| 23908 | - | Drum Front and AUTOFEED Assembly |
| 23913 | A-39AF | Replacement AUTOFEED Cartridge |
| 41937 | - | RIDGID® Leather Drain Cleaning Gloves |
| 70032 | - | RIDGID® PVC Drain Cleaning Gloves |

Drum Machines



K-400 DRUM MACHINE

- 1 1/2" to 4" (30 mm to 110 mm) Drain Lines
- The Model K-400 offers several unique, user-friendly features to make the toughest drain cleaning jobs easier and hassle-free. Designed with a sleek profile, the Model K-400 is a great fit for drain cleaners, service plumbers, facility and institutional maintenance departments and property management companies.
- 3/8" (10 mm) cable best for 1 1/2" to 3" (40 mm to 75 mm) lines.
- 1/2" (12 mm) cable best for 3" to 4" (50 mm to 110 mm) lines.
- **Integrated Transport Cart** – easy movement to and from the job site. Heavy-duty, large wheels easily navigate over bumps and up stairs.
- **Retractable Handle** – high-handle height during transport.
- **Cable Control System** – causes the drum to stop spinning when the blade becomes lodged in a blockage, limits potential for cable to flip-over in the drum and helps to indicate to operator when blockages are encountered.
- **"Solid Core" Cable** – uses tough 3/8" (10 mm) or 1/2" (12 mm) Integral Wound (IW) solid core cable that is rugged and kink resistant.
- **AUTOFEED® Control** – offered as an accessory, this patented, automatic cable feed powers cable in and out of the drain. Reverse the direction of the AUTOFEED and the cable feeds back into the drum.

SPECIFICATIONS

- **Drum Capacity** – 100' (30,5 m) of 3/8" (10 mm) diameter cable or 75' (22,5 m) of 1/2" (12 mm) diameter cable
- **Motor** – 380 watt, motor spins cable at 165 RPM
- **Weight (Machine Only)** – 45 lbs. (20.4 kg)
- **Dimensions** – Length 21" (53 cm) 24" (61 cm) with AUTOFEED, Height 23" (58,5 cm) Width 17" (43.2 cm)
- All Model K-400 machines are supplied with RIDGID® drain cleaning gloves and operator's manual

| Catalog No. | Model No. | Description | Voltage | | Weight | |
|-------------|-----------------------|---|---------|-----|--------|--|
| | | | V | lb. | kg | |
| 52363 | K-400 with C-32 IW | K-400 Machine with Gloves & Std. Equipment: C-32 IW 3/8" x 75' (10 mm x 23 m) Solid Core (Integral Wound) Cable, T-260 Tool Set | 115 | 68 | 31.0 | |
| 26993 | K-400 with C-31 IW | K-400 Machine with Gloves & Std. Equipment: C-31 IW 3/8" x 50' (10 mm x 15.2 m) Solid Core (Integral Wound) Cable, T-260 Tool Set Includes: T-202 Bulb Auger, T-205 "C" Cutter, T-211 Spade Cutter, A-13 Coupling Pin | 115 | 60 | 27.2 | |
| 26998 | K-400 with C-45 IW | K-400 Machine with Gloves & Std. Equipment: C-45 IW 1/2" x 75' (12 mm x 23 m) Solid Core (Integral Wound) Cable, T-260 Tool Set | 115 | 81 | 37.0 | |
| 27003 | K-400 with C-44 IW | K-400 Machine with Gloves & Std. Equipment: C-44 IW 1/2" x 50' (12 mm x 15.2 m) Solid Core (Integral Wound) Cable, T-260 Tool Kit | 115 | 68 | 31.0 | |
| 27008 | K-400 AF with C-32 IW | K-400 Machine with Gloves & Std. Equipment: Two-Wheel Cart, AUTOFEED, C-32 IW 3/8" x 75' (10 mm x 23 m) Solid Core (Integral Wound) Cable, T-260 Tool Set | 115 | 79 | 36.0 | |
| 27013 | K-400 AF with C-45 IW | K-400 Machine with Gloves & Std. Equipment: AUTOFEED, C-45 IW 1/2" x 75' (12 mm x 23 m) Solid Core (Integral Wound) Cable, T-260 Tool Set | 115 | 93 | 42.0 | |
| 27033 | K-400 with C-45 IW | K-400 Machine with RIDGID Drain Cleaning Gloves – C-45 IW 1/2" x 75' (12 mm x 23 m) Solid Core (Integral Wound) Cable – T-260 Tool Set | 230 | 81 | 37.0 | |
| 28103 | K-400 AF with C-45 IW | K-400 Machine with RIDGID Drain Cleaning Gloves – AUTOFEED – C-45 IW 1/2" x 75' (12 mm x 23 m) Solid Core (Integral Wound) Cable – T-260 Tool Set | 230 | 93 | 42.0 | |
| 28098 | K-400 AF with C-32 IW | K-400 Machine with RIDGID Drain Cleaning Gloves – AUTOFEED – C-32 IW 3/8" x 75' (10 mm x 23 m) Solid Core (Integral Wound) Cable – T-260 Tool Set | 230 | 79 | 36.0 | |

Standard Equipment

| Catalog No. Model No. | 24853 K-400 w/C-32 IW | 26993 K-400 w/C-31 IW | 26998 K-400 w/C-45 IW | 27003 K-400 w/C-44 IW | 27008 K-400 AF w/C-32 IW | 27013 K-400 AF w/C-45 IW |
|---|-----------------------|-----------------------|-----------------------|-----------------------|--------------------------|--------------------------|
| 49002 - Tool Set [3/8" (10 mm) - K-400] Includes: – T-202 Bulb Auger – T-205 "C" Cutter – T-211 Spade Cutter – A-13 Pin Key | • | • | • | • | • | • |
| 87582 - 3/8" (10 mm) x 75' (23 m) IWCable | • | | | | • | |
| 87577 - 3/8" (10 mm) x 50' (15 m) IW Cable | | • | | | | |
| 87597 - 1/2" (12 mm) x 75' (23m) IW Cable | | | • | | | • |
| 87592 - 1/2" (12 mm) x 50' (15 m) IW Cable | | | | • | | |
| 26773 - K-400 AutoFeed Assembly | | | | | • | • |



Cables

| | Catalog No. | Model No. | Description | Weight | |
|------------|-------------|-----------|--------------------------------------|--------|------|
| | | | | lb. | kg |
| 3/8"-10 mm | 87577 | C-31IW | 3/8" (10 mm) x 50' (15 m) IW Cable | 18 | 8.2 |
| | 87582 | C-32IW | 3/8" (10 mm) x 75' (23 m) IWCable | 26 | 11.8 |
| | 87587 | C-33IW | 3/8" (10 mm) x 100' (30 m) IW Cable | 34 | 15.4 |
| | 91037 | | Repair End for 3/8" (10 mm) IW Cable | 0.5 | 0.2 |
| 1/2"-12 mm | 87592 | C-44IW | 1/2" (12 mm) x 50' (15 m) IW Cable | 18 | 8.2 |
| | 87597 | C-45IW | 1/2" (12 mm) x 75' (23m) IW Cable | 26 | 11.8 |
| | 91042 | | Repair End for 1/2" (12 mm) IW Cable | 0.6 | 0.3 |



Tools

| | Catalog No. | Model No. | Description | Replac. Blade(s) |
|--|-------------|-----------|--|------------------|
| | 62990 | T-201 | Straight Auger, 5" (125 mm) Long | - |
| | 62995 | T-202 | Bulb Auger, 1 1/8" (29 mm) O.D. | - |
| | 63000 | T-203 | Bulb Auger 7/8" (22 mm) O.D. | - |
| | 63005 | T-205 | "C" Cutter, 1 3/8" (35 mm) | 97835 |
| | 63010 | T-206 | Funnel Auger, 3" (80 mm) Long | - |
| | 63015 | T-207 | Spiral Cutter, 1 1/4" (32 mm) | 97840 |
| | 63020 | T-208 | Spiral Cutter, 1 1/2" (40 mm) | 97895 |
| | 63025 | T-209 | Spiral Cutter, 2" (50 mm) | 97900 |
| | 63030 | T-210 | Spade Cutter, 1" (25 mm) | 97905 |
| | 63035 | T-211 | Spade Cutter, 1 3/8" (35 mm) | 97825 |
| | 63040 | T-212 | Spade Cutter, 1 3/4" (45 mm) | 92850 |
| | 63045 | T-213 | 4-Blade Cutter, 1" (25 mm) | 97795 |
| | 63050 | T-214 | 4-Blade Cutter, 1 3/8" (35 mm) | 97910 |
| | 63055 | T-215 | 4-Blade Cutter, 1 3/4" (45 mm) | 97915 |
| | 63060 | T-216 | Chain Knocker, 2" (50 mm) | 98000 |
| | 63065 | T-217 | Drop Head Auger, 4" (110 mm) Long | - |
| | 49002 | T-260 | Tool Set 3/8" (10 mm) - K-400] Includes: - T-202 Bulb Auger - T-205 "C" Cutter - T-211 Spade Cutter - A-13 Pin Key | - |

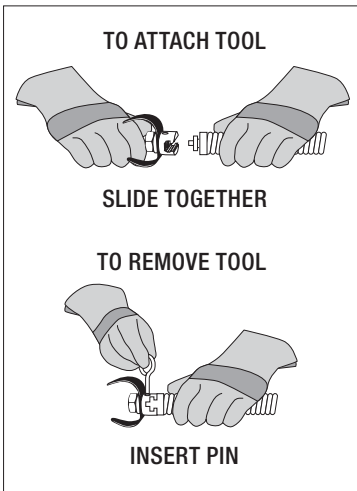

Accessories

| | Catalog No. | Model No. | Description | Weight | |
|--|-------------|-----------|---|--------|-----|
| | | | | lb. | kg |
| | 41937 | - | RIDGID® Leather Drain Cleaning Gloves | | |
| | 70032 | - | RIDGID® PVC Drain Cleaning Gloves | 1/2 | 0.2 |
| | 59230 | A-13 | 3/8" Cable Pin Key | | |
| | 52343 | - | K-400 AutoFeed Assembly | 2 | 0.9 |
| | 27048 | - | Drum Assembly | 10 | 4.5 |
| | 92607 | - | 3/8" x 1/2" Tool Adaptor | | |
| | 92682 | - | 3/8" x 1/2" Drop Head Adaptor | 1/2 | 0.2 |
| | 92687 | - | Drop Head Tool Adaptor 1/2" (12 mm) | | |
| | 26778 | - | Guide Hose Assembly | 2 | 0.9 |
| | 51317 | C-9 | 5/8" (16 mm) x 10' (3,1 m) Heavy- Duty Wind | 5 | 2.2 |

(TOOLTIP)

Always start with a straight auger to and determine what you are trying to clean. Then chose the correct cutter to clear the drain.

Drum Machines

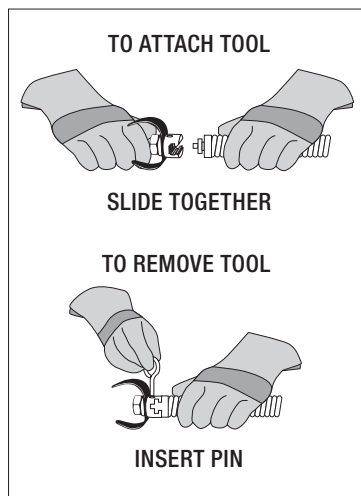

For C-4, C-6, C-6/C, C-7, C-8, C-9, C-10, C-11, C-12, C-14, C-15, C-31, C-32, C-33, C-44, C-45, and C-46 & all IW Cables.

K-3800 DRUM MACHINE

- 3/4" (20 mm) to 4" (110 mm) Drain Lines
- A powerful, easy to transport, versatile machine for cleaning indoor drains. Requires minimal set-up to clean sink lines, floor drains and roof vents.
- Rugged, corrosion-resistant molded cable drum won't dent or rust. The drum tilt adjusts for proper cable feed angle. Inner-drum guards against cable flip-over inside the drum.
- Cable drum quick-release and built-in hand-holds allow easy cable change and transport.
- Maximum drum capacity is 100' (30,5 m) of 3/8" (10 mm) or 90' (27 m) of 1/2" (12 mm) continuous length cable
- 3/8" (10 mm) cable best for 1 1/2" (40 mm) to 3" (75 mm) lines up to 100' (30,5 m)
- 1/2" (12 mm) cable best for 2" (50 mm) to 4" (110 mm) lines up to 90' (27 m)
- Optional sink drum holds up to 50' (15 m) of 5/16" (8 mm) or 1/4" (6 mm) cable
- Ideal for cleaning through 3/4" (20 mm) to 1 1/2" (40 mm) sink traps
- Powerful 175-watt universal motor spins cable at 240 RPM. When cable hits blockage, motor gears down automatically to deliver more power and enhance operator control.
- Tools connect to cable in seconds.
- Optional heavy duty AUTOFEED® system.
- Includes RIDGID® leather drain cleaning gloves and operator's manual.



Machine Options

| Catalog No. | Model No. | Description | Voltage | | | Weight | |
|-------------|------------------|---|---------|-----|------|--------|--|
| | | | V | lb. | kg | | |
| 53107 | K-3800 | K-3800 Machine with Gloves | 115 | 42 | 19.0 | | |
| 53112 | K-3800 with C-31 | K-3800 Machine with Std. Equip: C-31, 3/8" x 50' (10 mm x 15.2 m) Cable, T-202 Bulb Auger, T-205 "C" Cutter, T-211 Spade Cutter, A-13 Pin Key, Pair of Gloves | 115 | 65 | 29.2 | | |
| 53117 | K-3800 with C-32 | K-3800 Machine with Std. Equip: C-32, 3/8" x 75' (10 mm x 22.8 m) Cable, T-202 Bulb Auger, T-205 "C" Cutter, T-211 Spade Cutter, A-13 Pin Key, Pair of Gloves | 115 | 71 | 32.2 | | |
| 53122 | K-3800 with C-45 | K-3800 Machine with Std. Equip: C-45, 1/2" x 75' (12 mm x 22.8 m) Cable, T-102 Funnel Auger, T-142 Knife Blade Cutter, T-107 Spade Cutter, A-12 Pin Key, Pair of Gloves | 115 | 83 | 37.7 | | |
| 53127 | K-3800 with C-46 | K-3800 Machine with Std. Equip: C-46, 1/2" x 90' (12 mm x 27.4 m) Cable, T-102 Funnel Auger, T-142 Knife Blade Cutter, T-107 Spade Cutter, A-12 Pin Key, Pair of Gloves | 115 | 91 | 41.3 | | |
| 59462 | K-3800 | K-3800 Machine with Gloves | 230 | 42 | 19.0 | | |
| 63822 | K-3800 with C-45 | K-3800 Machine with Std. Equip: C-45, 1/2" x 75' (12 mm x 22.8 m) Cable, T-102 Funnel Auger, T-142 Knife Blade Cutter, T-107 Spade Cutter, A-12 Pin Key, Pair of Gloves | 230 | 83 | 37.7 | | |
| 63827 | K-3800 with C-32 | K-3800 Machine with Std. Equip: C-32, 3/8" x 75' (10 mm x 22.8 m) Cable, T-202 Bulb Auger, T-205 "C" Cutter, T-211 Spade Cutter, A-13 Pin Key, Pair of Gloves | 230 | 71 | 32.2 | | |



Standard Equipment

| Catalog No. Model No. | 53107 K-3800 | 53112 K-3800 w/C-31 | 53117 K-3800 w/C-32 | 53122 K-3800 w/C-45 | 53127 K-3800 w/C-46 | 59462 K-3800 | 63822 K-3800 w/C-45 | 63827 K-3800 w/C-32 |
|--|-----------------|------------------------|------------------------|------------------------|------------------------|-----------------|------------------------|------------------------|
| 41937 - RIDGID Leather Drain Cleaning Gloves | • | • | • | • | • | • | • | • |
| 37842 - 3/8" (10 mm) x 50' (15m) IC Cable | | • | • | | | | | |
| 49002 - Tool Set [3/8" (10 mm) - K-400] Includes: - T-202 Bulb Auger - T-205 "C" Cutter - T-211 Spade Cutter - A-13 Pin Key | | • | • | | | | | • |
| 37862 - 1/2" (12 mm) x 75' (23 m) IC Cable | | | | • | | | • | |
| 54992 - Tool Set: - T-102 Funnel Auger - T-142 Knife Blade Cutter - T-107 Spade Cutter - A-12 Pin Key | | | | • | • | | • | |
| 55467 - 1/2" (12 mm) x 90' (28m) IC Cable | | | | | • | | | |
| 37847 - 3/8" (10 mm) x 75' (23 m) IC Cable | | | | | | | | • |

Inner Core (IC) Cables

| | Catalog No. | Model No. | Description | Weight | |
|---|-------------|-----------|--|--------|------|
| | | | | lb. | kg |
|  | 37842 | C-31 | 3/8" (10 mm) x 50' (15m) IC Cable | 18 | 8.2 |
| | 37847 | C-32 | 3/8" (10 mm) x 75' (23 m) IC Cable | 26 | 11.8 |
| | 37852 | C-33 | 3/8" (10 mm) x 100' (30m) IC Cable | 34 | 15.4 |
| | 51752 | T-122 | Repair End, 3/8" (10 mm) | 1 | 0.5 |
|  | 37857 | C-44 | 1/2" (12 mm) x 50' (15m) IC Cable | 27 | 12.2 |
| | 37862 | C-45 | 1/2" (12 mm) x 75' (23m) IC Cable | 39 | 17.7 |
| | 37867 | C-45HC | 1/2" (12 mm) x 75' (23m) Hollow Core Cable | 38 | 17.2 |
| | 55467 | C-46 | 1/2" (12 mm) x 90' (28m) IC Cable | 47 | 21.2 |
| | 59917 | T-121 | Repair End, 1/2" (12 mm) | 3/4 | 0.8 |







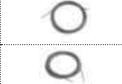
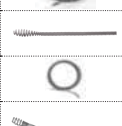

Integrated Wound (IW) Cables

| | Catalog No. | Model No. | Description | Weight | |
|---|-------------|-----------|--------------------------------------|--------|------|
| | | | | lb. | kg |
|  | 87577 | C-31IW | 3/8" (10 mm) x 50' (15 m) IW Cable | 18 | 8.2 |
| | 87582 | C-32IW | 3/8" (10 mm) x 75' (23 m) IW Cable | 26 | 11.8 |
| | 87587 | C-33IW | 3/8" (10 mm) x 100' (30 m) IW Cable | 34 | 15.4 |
| | 91037 | | Repair End for 3/8" (10 mm) IW Cable | 1/2 | 0.2 |
|  | 87592 | C-44IW | 1/2" (12 mm) x 50' (15 m) IW Cable | 18 | 8.2 |
| | 87597 | C-45IW | 1/2" (12 mm) x 75' (23m) IW Cable | 26 | 11.8 |
| | 91042 | | Repair End for 1/2" (12 mm) IW Cable | 3/5 | 0.3 |

Sink Drum Cables

| | Catalog No. | Model No. | Description | Weight | |
|---|-------------|-----------|---|--------|-----|
| | | | | lb. | kg |
|  | 50652 | S-2 | 1/4" (6 mm) x 25' (7,6 m) with Funnel Auger | 3 1/2 | 1.6 |
| | 50657 | S-3 | 1/4" (6 mm) x 35' (10,7 m) with Funnel Auger | 5 | 2.2 |
| | 56782 | C-11C | 5/16" (8 mm) x 25' (7.6 m) Inner Core with Bulb Auger | 4 | 1.8 |
|  | 56792 | C-131C | 5/16" x 35' (8 mm x 10.7 m) Inner Core with Bulb Auger | 5 1/2 | 2.5 |
| | 56787 | C-21C | 5/16" (8 mm) x 25' (7.6 m) Inner Core with Drop Head Auger | 4 | 1.8 |
| | 56797 | C-231C | 5/16" (8 mm) x 35' (10,7 m) Inner Core with Drop Head Auger | 5 1/2 | 2.5 |













Accessories

| | Catalog No. | Model No. | Description | Weight | |
|---|-------------|-----------|--|--------|-----|
| | | | | lb. | kg |
|  | 55002 | A-380 | Standard Drum Assembly | 12 1/2 | 5.6 |
| | 55007 | A-381 | Sink Drum Assembly | | |
|  | 55012 | A-381-A | Sink Drum with 25' (7,6 m) x 5/16" (8 mm) IC Cable w/Bulb Head | 16 1/2 | 7.5 |
|  | 41937 | | RIDGID® Leather Drain Cleaning Gloves | 1/2 | 0.2 |
|  | 70032 | | RIDGID® PVC Drain Cleaning Gloves | | |
|  | 59230 | A-13 | 3/8" Cable Pin Key | 18 | 8.2 |
| | 59225 | A-12 | 1/2" Cable Pin Key | | |
|  | 55017 | | Transport Cart | 18 | 8.2 |
|  | 60087 | A3800 PF | AUTOFEED® Assembly | 7 3/8 | 3.3 |
|  | 62412 | | Guide Hose Adapter for Sink Drum | 3 1/2 | 1.6 |

Tools Fit 3/8" (10 mm) IC, 3/8" (10 mm) IW and 1/2" (12 mm) IW Cables

| | Catalog No. | Model No. | Description | Replac. Blade(s) |
|---|-------------|-----------|---|------------------|
|  | 62990 | T-201 | Straight Auger, 5" (125 mm) Long | - |
|  | 62995 | T-202 | Bulb Auger, 1 1/8" (29 mm) O.D. | |
|  | 63000 | T-203 | Bulb Auger 7/8" (22 mm) O.D. | |
|  | 54837 | T-204 | "C" Cutter 1" (25 mm) | 54832 |
|  | 63005 | T-205 | "C" Cutter, 1 3/8" (35 mm) | 97835 |
|  | 52812 | T-230 | H-D "C" Cutter, 2" (50 mm) | 92815 |
|  | 52817 | T-231 | H-D "C" Cutter, 2 1/2" (65 mm) | 92820 |
|  | 52822 | T-232 | H-D "C" Cutter, 3" (80 mm) | 92835 |
|  | 63010 | T-206 | Funnel Auger, 3" (80 mm) Long | - |
|  | 63015 | T-207 | Spiral Cutter, 1 1/4" (32 mm) | 97840 |
|  | 63020 | T-208 | Spiral Cutter, 1 1/2" (40 mm) | 97895 |
|  | 63025 | T-209 | Spiral Cutter, 2" (50 mm) | 97900 |
|  | 63030 | T-210 | Spade Cutter, 1" (25 mm) | 97905 |
|  | 63035 | T-211 | Spade Cutter, 1 3/8" (35 mm) | 97825 |
|  | 63040 | T-212 | Spade Cutter, 1 3/4" (45 mm) | 92850 |
|  | 63045 | T-213 | 4-Blade Cutter, 1" (25 mm) | 97795 |
|  | 63050 | T-214 | 4-Blade Cutter, 1 3/8" (35 mm) | 97910 |
|  | 63055 | T-215 | 4-Blade Cutter, 1 3/4" (45 mm) | 97915 |
|  | 63060 | T-216 | Chain Knocker, 2" (50 mm) | 98000 |
|  | 63065 | T-217 | Drop Head Auger, 4" (110 mm) Long | - |
|  | 55457 | T-225 | Retrieving Auger | |
|  | 12128 | T-240 | Tool Set (3/8"- K-380): T-202 Bulb Auger, T-211 Spade Cutter, A-13 Pin Key | - |
|  | 49002 | T-260 | Tool Set (3/8" (10 mm) - K-400) Includes: - T-202 Bulb Auger - T-205 "C" Cutter - T-211 Spade Cutter - A-13 Pin Key | - |

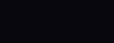
Tools Fit 1/2" (12mm) IC Cables

| | Catalog No. | Model No. | Description | Replac. Blade(s) |
|---|-------------|-----------|---|------------------|
|  | 62850 | T-101 | Straight Auger | - |
|  | 62855 | T-102 | Funnel Auger | |
|  | 62865 | T-104 | "H" Cutter, 2 1/2" (65 mm) | 97800 |
|  | 62870 | T-105 | Grease Cutter, 2 1/2" (65 mm) | 97920 |
|  | 62875 | T-106 | Grease Cutter, 3 1/2" (87 mm) | 97925 |
|  | 62880 | T-107 | Spade Cutter, 1 3/4" (45 mm) | 92850 |
|  | 62930 | T-112 | 4-Blade Cutter, 1 3/4" (45 mm) | 97915 |
|  | 62935 | T-113 | 4-Blade Cutter, 3" (75 mm) | 97910 |
|  | 62940 | T-114 | Chain Knocker for 4" lines | 97985 |
|  | 27642 | T-125 | Straight Retrieving Auger | - |
|  | 54842 | T-141 | Knife Blade Cutter 1 1/2" (40 mm) | 54847 |
|  | 54852 | T-142 | Knife Blade Cutter 2 1/2" (65 mm) | 97800 |
|  | 54992 | T-270 | Tool Set: - T-102 Funnel Auger - T-142 Knife Blade Cutter - T-107 Spade Cutter - A-12 Pin Key | - |
|  | 92687 | | Drop Head Tool Adaptor 1/2" (12 mm) | - |

Drum Machines



K-6200 DRUM MACHINE

- 3" to 6" (75 to 150 mm) Drain/Sewer Lines Up to 200' (61 m)
- K-6200 machines offer superior maneuverability and a small footprint allows easy access to tight work areas. It comes equipped with either Inner Core cable or Integral Wound cable. Recommend 5/8" (16 mm) cable for 3" (75 mm) to 6" (150 mm) drain lines up to 200' (61 m).
- **Patented Cable Control System** – Causes the drum to slow down when the blade becomes lodged in a blockage. Limits potential for cable flip over.
- **Direct Drive Design** – 4/10 HP universal motor and gearbox bear down as torque builds. Audible warnings let operator know when blockage is encountered. Drum requires no adjustments to stay aligned and tight on drive shaft.
- **Easy Maintenance Construction** – Separate drum and machine in seconds. Inner drum and guide tube remove easily to maintain or replace cable.
- **Designed Durable and Stable** – Low center of gravity frame design and custom kickstand keep machine firmly anchored during operation. Rugged, corrosion-resistant polyethylene drum is rust and dent proof. Double tubular frame is lightweight and designed for extra strength.
- **AUTOFEED® Control and Standard Accessories** – Powerful feed mechanism is built to last and is easily maintained. AUTOFEED control, toolbox and selection of cutters included in all models.

SPECIFICATIONS

- **Line Capacity** – 3" - 6" (75-150 mm) Lines, up to 200' (61 m)
- **Drum Capacity** – 100' (30.5 m) of 5/8" (16 mm) cable
- **Weight (Machine & 100' (30.5 m) of Cable)** – 180 lbs. (81.6 kg)
- **Size** – Length 29 1/2" (75 cm, Height 43 1/2" (110 cm) (max.), Width 18 3/4", (47 cm)

MOTOR

- **Type** – 115V/60 Hz, 5.6 Amp, Reversible, Universal AC Motor
- **Rating** – 4/10 HP, 285 RPM
- **CSA approved** – Approved to UL standards (NRTLCL)















Machine Options

| Catalog No. | Model No. | Description | Weight | |
|-------------|---------------------------|--|--------|------|
| | | | lb. | kg |
| 93557 | K-6200 with C-24 HD Cable | Machine, Standard Accessories and 5/8" x 100' (16 mm x 30.5 m) IW Solid Core Cable | 180 | 81.8 |
| 95732 | K-6200 with C-24 | Machine, Standard Accessories and 5/8" x 100' (16 mm x 30.5 m) Inner Core Cable | | |
| 95737 | K-6200 | Machine with 5/8" (16 mm) Pigtail & Standard Accessories | 98 | 44.5 |















Standard Equipment

| Catalog No. Model No. | 93557 K-6200 w/C24 HD Cable | 95732 K-6200 w/C-24 | 95737 K-6200 |
|--|--------------------------------|------------------------|-----------------|
| 58192 - 5/8" (16 mm) x 100' HC Cable (30.5m) | ● | | |
| 59360 - Tool Box | ● | ● | ● |
| 70032 - RIDGID PVC Drain Cleaning Gloves | ● | ● | ● |
| 92495 - Spade Cutter, 1 3/4" (45 mm) | ● | ● | ● |
| 92510 - Double Cutter, 2" (50 mm) | ● | ● | ● |
| 92520 - Double Cutter, 3" (75 mm) | ● | ● | ● |
| 92525 - Double Cutter, 4" (110 mm) | ● | ● | ● |
| 92555 - 5/8" (16 mm) x 2' (50 mm) Leader | ● | ● | ● |

Cables and Leaders

| | Catalog No. | Model No. | Description | Weight | | |
|---|---|-----------|-------------|--|--------|------|
| | | | | lb. | kg | |
|  |  | 37628 | C-25 HD | 25' HD Cable (7,6m) | 24 | 10.9 |
| |  | 37633 | C-26 HD | 50' HD Cable (15,2m) | 43 | 19.5 |
| |  | 37638 | C-27 HD | 75' HD Cable (30,5m) | 63 | 28.6 |
| |  | 37643 | C-24 HD | 100 HD Cable (30,5m) | 84 | 38.1 |
| |  | 44122 | | 5/8" (16 mm) Pigtail, 4 1/2' (1.4 m) Long | 2 1/2 | 1.1 |
| |  | 58192 | C-24HC | 5/8" (16 mm) x 100' HC Cable (30.5 m) | 70 1/2 | 32.1 |
| |  | 43647 | C-24 | 5/8" (16 mm) x 100' IC Cable (30.5m) | 84 | 38.1 |
| |  | 92460 | C-25 | 5/8" (16 mm) x 25' IC Cable (7.6m) | 24 | 10.9 |
| |  | 92465 | C-26 | 5/8" (16 mm) x 50' IC Cable (15.2m) | 43 | 19.5 |
| |  | 92470 | C-27 | 5/8" (16 mm) x 75' IC Cable (22.9m) | 63 | 28.6 |
| |  | 92555 | T-458 | 5/8" (16 mm) x 2' (50 mm) Leader | 2 | 0.8 |
| |  | 95737 | K-6200 | Machine with 5/8" (16 mm) Pigtail & Standard Accessories | 98 | 44.5 |
| |  | 32737 | C-27HC | 5/8" (16 mm) x 75' HC Cable (23 m) | 52 3/4 | 23.9 |

Tools and Replacement Blades – Fit 5/8" (16 mm) and 3/4" (20 mm) Cables

| | Catalog No. | Model No. | Description | Replac. Blade(s) | Replac. Holder |
|---|-------------|-----------|----------------------------------|------------------|----------------|
|  | 51762 | T-409 | H-D Bulb Auger, 1 3/4" (45 mm) | - | - |
|  | 92485 | T-403 | P-Trap Cutter, 3" (75 mm) | 92835 | 92900 |
|  | 92490 | T-404 | P-Trap Cutter, 3 1/2" (87 mm) | 92840 | 92900 |
|  | 92495 | T-406 | Spade Cutter, 1 3/4" (45 mm) | 92850 | 92915 |
|  | 92500 | T-407 | Retrieving Auger 2 9/16" (65 mm) | - | - |
|  | 92505 | T-408 | Sawtooth Cutter, 3" (75 mm) | 92890 | 92915 |
|  | 92510 | T-411 | Double Cutter, 2" (50 mm) | 92815 | 92905 |
|  | 92515 | T-412 | Double Cutter, 2 1/2" (65 mm) | 92820 | 92905 |
|  | 92520 | T-413 | Double Cutter, 3" (75 mm) | 92825 | 92910 |
|  | 92525 | T-414 | Double Cutter, 4" (110 mm) | 92830 | 92910 |
|  | 92530 | T-416 | Double Cutter, 6" (150 mm) | 92855 | 92910 |
|  | 92535 | T-432 | 3-Blade Cutter 2" (50 mm) | 92860 | 92895 |
|  | 92545 | T-434 | 3-Blade Cutter 4" (110 mm) | 92870 | 92895 |
|  | 92550 | T-436 | 3-Blade Cutter 6" (150 mm) | 92875 | 92895 |

Accessories

| Catalog No. | Description |
|-------------|-----------------------------------|
| 92540 | 3-Blade Cutter 3" (75 mm) |
| 49032 | Front Guide Hose Assembly |
| 59360 | Tool Box |
| 70032 | RIDGID® PVC Drain Cleaning Gloves |
| 91047 | 5/8" IW Cable Repair Coupling |
| 95792 | Swivel Loading Wheel Assembly |
| 95797 | Lifting Hook - K-6200 |
| 95802 | K-6200 Drum Assy. w/5/8" Pigtail |
| 95807 | K-3800 Drum Assy. w/6200 Adapters |
| 95812 | AUTOFEED® Assembly |
| 95822 | K-3800 to K-6200 Adapter Kit Only |

Drum Machines

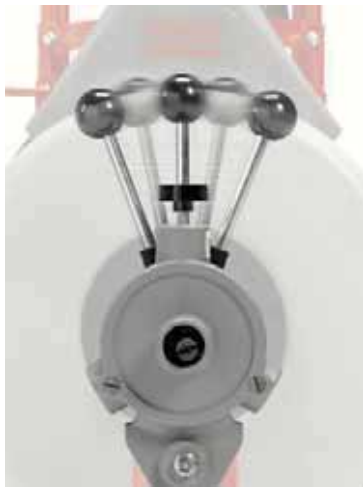

K-750 DRUM MACHINE

- 3" to 8" (75 to 200 mm) Drain/Sewer Lines
- Versatile AUTOFEED® adjusts for either 5/8" or 3/4" cable with a twist of a screwdriver.
- Recommend 5/8" (16 mm) cable for 3" to 6" (75 to 150 mm) drain lines up to 150' (48 m).
- Recommend 3/4" (20 mm) cable for 4" to 8" (100 to 200 mm) drain lines up to 200' (62 m).
- Powerful, self-contained machine ideal for lateral lines. Easy to transport, minimal set-up – attach a tool and go.
- AUTOFEED control advances and retrieves cable with a push of a lever, up to 20' (6 m) per minute.
- Versatile AUTOFEED control adjusts for either 5/8" (16 mm) or 3/4" (20 mm) cable with a twist of a screwdriver.
- Cable spins at 200 RPM.
- Tough, corrosion-resistant cable drum withstands harsh treatment and abuse. It will not dent or corrode and cleans easily.
- Drum holds 100' (30.5 m) of 3/4" (20 mm) or 125' (35 m) of 5/8" (16 mm) cable and is designed for quick, easy removal.
- Balanced design gives the machine a lightweight "feel." Transport wheels ease loading into service truck/van.
- Equipped with 550-watt induction motor.
- Approved by CSA to CSA and UL Standards (115V only).
- Includes RIDGID® PVC drain cleaning gloves and operators manual.

Machine Options

| Catalog No. | Model No. | Description | Voltage | | | Weight | | |
|-------------|-----------------|--|---------|-----|-------|--------|--|--|
| | | | V | lb. | kg | | | |
| 41977 | K-750 | Machine with Gloves and AUTOFEED - 3/4" (20 mm) Pigtail | 115 | 114 | 51.9 | | | |
| 51402 | | Machine with Gloves and AUTOFEED - 5/8" (16 mm) Pigtail | 115 | 113 | 51.3 | | | |
| 42002 | K-750 with C-75 | Machine with One Pair of Gloves, AUTOFEED, Standard 3/4" (20 mm) Tool Set, and: C-75, 75' (23 mm) x 3/4" (20 mm) Cable | 115 | 206 | 93.6 | | | |
| 42007 | K-750 | Machine with One Pair of Gloves, w/C-100 AUTOFEED, Standard 3/4" (20 mm) Tool Set, and: C-100, 100' (30.5 mm) x 3/4" (20 mm) Cable | 115 | 234 | 106.3 | | | |
| 42012 | K-750 with C-27 | Machine with One Pair of Gloves, AUTOFEED, Standard 5/8" (16 mm) Tool Set, and: C-27, 75' (23 mm) x 5/8" (16 mm) Cable | 115 | 182 | 82.7 | | | |
| 47047 | K-750 with C-24 | Machine with One Pair of Gloves, AUTOFEED, Standard 5/8" (16 mm) Tool Set, and: C-24, 100' (30.5 mm) x 5/8" (16 mm) Cable | 115 | | | | | |
| 44202 | K-750 | Machine with Gloves and AUTOFEED - 3/4" (20 mm) Pigtail | 230 | 114 | 51.9 | | | |
| 51407 | | Machine with Gloves and AUTOFEED - 5/8" (16 mm) Pigtail | 230 | 113 | 51.3 | | | |
| 44212 | K-750 with C-27 | Machine with One Pair of Gloves, w/C-100 AUTOFEED, Standard 3/4" (20 mm) Tool Set, and: C-100, 100' (30.5 mm) x 3/4" (20 mm) Cable | 230 | 234 | 106.3 | | | |
| 44217 | | Machine with One Pair of Gloves, AUTOFEED, Standard 5/8" (16 mm) Tool Set, and: C-27, 75' (23 mm) x 5/8" (16 mm) Cable | 230 | 182 | 82.7 | | | |

STANDARD 3/4" (20 MM) TOOL SET INCLUDES

- T-406 Spade Cutter
- T-407 Retrieving Auger
- T-411 2" (50 mm) Cutter
- T-413 3" (75 mm) Cutter
- T-414 4" (110 mm) Cutter



STANDARD 5/8" (16 MM) TOOL SET INCLUDES

- T-403 3" (75 mm) P-Trap Cutter
- T-407 Retrieving Auger
- T-406 Spade Cutter
- T-411 2" (50 mm) Cutter
- T-413 3" (75 mm) Cutter



Standard Equipment

| Catalog No. Model No. | 41977 K-750 | 51402 K-750 | 42002 K-750 w/C-75 | 42007 K-750 | 42012 K-750 w/C-27 | 47047 K-750 w/C-24 | 44202 K-750 | 51407 K-750 | 44212 K-750 | 44217 K-750 w/C-27 |
|--|-------------|-------------|--------------------|-------------|--------------------|--------------------|-------------|-------------|-------------|--------------------|
| 41937 - RIDGID Leather Drain Cleaning Gloves | • | • | • | • | • | • | • | • | • | • |
| 41212 - 3/4" (20 mm) x 75' IC Cable (22.9m) | | | • | | | | | | | |
| 59360 - Tool Box | | | • | • | | | | | • | |
| 92495 - Spade Cutter, 1 3/4" (45 mm) | | | • | • | • | • | | | • | • |
| 92500 - Retrieving Auger 2 9/16" (65 mm) | | | • | • | • | • | | | • | • |
| 92510 - Double Cutter, 2" (50 mm) | | | • | • | • | • | | | • | • |
| 92520 - Double Cutter, 3" (75 mm) | | | • | • | • | • | | | • | • |
| 92525 - Double Cutter, 4" (110 mm) | | | • | • | | | | | • | |
| 41697 - 3/4" (20 mm) x 100' IC Cable (30.5m) | | | | • | | | | | • | |
| 92470 - 5/8" (16 mm) x 75' IC Cable (22.9m) | | | | | • | | | | | • |
| 92485 - P-Trap Cutter, 3" (75 mm) | | | | | • | • | | | | • |
| 43647 - 5/8" (16 mm) x 100' IC Cable (30.5m) | | | | | | • | | | | |



Inner Core (IC) Cables

| | Catalog No. | Model No. | Description | Weight | |
|---|-------------|-----------|--------------------------------------|--------|------|
| | | | | lb. | kg |
|  | 92460 | C-25 | 5/8" (16 mm) x 25' IC Cable (7.6m) | 24 | 10.9 |
| | 92465 | C-26 | 5/8" (16 mm) x 50' IC Cable (15.2m) | 43 | 19.5 |
| | 92470 | C-27 | 5/8" (16 mm) x 75' IC Cable (22.9m) | 63 | 28.6 |
| | 43647 | C-24 | 5/8" (16 mm) x 100' IC Cable (30.5m) | 84 | 38.1 |
|  | 92475 | C-28 | 3/4" (20 mm) x 25' IC Cable (7.6m) | 30 | 13.9 |
| | 92480 | C-29 | 3/4" (20 mm) x 50' IC Cable (15.2m) | 60 | 27.2 |
| | 41212 | C-75 | 3/4" (20 mm) x 75' IC Cable (22.9m) | 93 | 42.5 |
| | 41697 | C-100 | 3/4" (20 mm) x 100' IC Cable (30.5m) | 122 | 55.3 |









Hollow Core Cables

| | Catalog No. | Model No. | Description | Weight | |
|---|-------------|-----------|---------------------------------------|--------|------|
| | | | | lb. | kg |
|  | 32737 | C-27HC | 5/8" (16 mm) x 75' HC Cable (23 m) | 52 3/4 | 23.9 |
| | 58192 | C-24HC | 5/8" (16 mm) x 100' HC Cable (30.5 m) | 70 1/2 | 32.1 |
|  | 47427 | C-75HC | 3/4" (20 mm) x 75' HC Cable (23 m) | 75 | 34.0 |
| | 47432 | z-100HC | 3/4" (20 mm) x 100' HC Cable (30.5 m) | 100 | 45.5 |

Leaders and Pig Tails

| | Catalog No. | Model No. | Description | Weight | |
|---|-------------|-----------|---|--------|-----|
| | | | | lb. | kg |
|  | 92555 | T-458 | 5/8" (16 mm) x 2' (50 mm) Leader | 2 | 0.9 |
|  | 92560 | T-468 | 3/4" (20 mm) x 2' (50 mm) Leader | 2 3/4 | 1.3 |
|  | 44122 | - | 5/8" (16 mm) Pigtail, 4 1/2' (1.4 m) Long | 2 1/2 | 1.1 |
| | 44117 | - | 3/4" Pigtail Assembly | 3 1/2 | 1.6 |













Accessories

| | Catalog No. | Model No. | Description | Weight | |
|---|-------------|-----------|--|--------|------|
| | | | | lb. | kg |
|  | 41982 | A-7534 | Drum Assembly with 3/4" (20 mm) Pigtail | 37 1/2 | 17.0 |
| | 43637 | A-7558 | Drum Assembly with 5/8" (16 mm) Pigtail | 33 | 15.0 |
|  | 43642 | A-75 | AUTOFEED Assembly | 8 | 3.5 |
|  | 41937 | - | RIDGID® Leather Drain Cleaning Gloves | 1/2 | 0.2 |
|  | 41992 | A-75PF | C-100IC Kit with Tools, 3/4" (20 mm) x 100' (30,5 m) | 8 | 3.5 |
|  | 49032 | | Front Guide Hose Assembly | 3 | 1.3 |
|  | 59360 | A-3 | Tool Box | 5 | 2.3 |
|  | 70032 | - | RIDGID® PVC Drain Cleaning Gloves | 1/2 | 0.2 |
|  | 46015 | | Key, Hex 5/32 | - | - |

Repair Fittings

| | Catalog No. | Model No. | Description | Weight | |
|---|-------------|-----------|------------------------------|--------|------|
| | | | | lb. | kg |
|  | 31487 | A-7570 | 5/8" (16 mm) Repair Splicer | 1 1/2 | 43.0 |
| | 31492 | A-7571 | 3/4" (20 mm) Repair Splicer | 2 | 57.0 |
| | 92805 | A-6582 | 5/8" (16 mm) Male Coupling | 1 | 28.0 |
| | 92810 | A-6583 | 5/8" (16 mm) Female Coupling | 2 | 57.0 |
| | 92880 | B-6840 | 3/4" (20 mm) Male Coupling | 1 | 28.0 |
| | 92885 | B-6841 | 3/4" (20 mm) Female Coupling | 2 | 57.0 |

Tools and Replacement Blades – Fit 5/8" (16 mm) and 3/4" (20 mm) Cables

| | Catalog No. | Model No. | Description | Replac. Blade(s) | Replac. Holder |
|---|-------------|-----------|----------------------------------|------------------|----------------|
|  | 92485 | T-403 | P-Trap Cutter, 3" (75 mm) | 92835 | 92900 |
|  | 92490 | T-404 | P-Trap Cutter, 3 1/2" (87 mm) | 92840 | 92900 |
|  | 92495 | T-406 | Spade Cutter, 1 3/4" (45 mm) | 92850 | 92915 |
|  | 92500 | T-407 | Retrieving Auger 2 9/16" (65 mm) | - | - |
|  | 92505 | T-408 | Sawtooth Cutter, 3" (75 mm) | 92890 | 92915 |
|  | 51762 | T-409 | H-D Bulb Auger, 1 3/4" (45 mm) | - | - |
|  | 92510 | T-411 | Double Cutter, 2" (50 mm) | 92815 | 92905 |
|  | 92515 | T-412 | Double Cutter, 2 1/2" (65 mm) | 92820 | 92905 |
|  | 92520 | T-413 | Double Cutter, 3" (75 mm) | 92825 | 92910 |
|  | 92525 | T-414 | Double Cutter, 4" (110 mm) | 92830 | 92910 |
|  | 92530 | T-416 | Double Cutter, 6" (150 mm) | 92855 | 92910 |
|  | 92535 | T-432 | 3-Blade Cutter 2" (50 mm) | 92860 | 92895 |
|  | 92540 | T-433 | 3-Blade Cutter 3" (75 mm) | 92865 | 92985 |
|  | 92545 | T-434 | 3-Blade Cutter 4" (110 mm) | 92870 | 92895 |
|  | 92550 | T-436 | 3-Blade Cutter 6" (150 mm) | 92875 | 92895 |

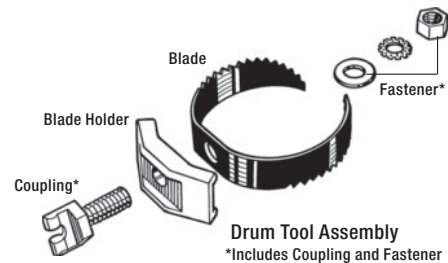

Drum Machines



K-7500 DRUM MACHINE

- 3" to 10" (75-250 mm) Lines
- Recommend 5/8" (16 mm) cable for 3" (75 mm) to 6" (150 mm) drain lines up to 250' (76 m).
- Recommend 3/4" (20 mm) cable for 4" (110 mm) to 10" (250 mm) drain lines up to 250' (76 m).
- Features performance, cable control, durability and maneuverability demanded by professional users. Ideal for tough jobs, such as roots.
- Cable spins at 200 RPM.
- Powerful, yet quiet, 600-watt universal motor and gearbox bear down as cutter engages tough obstructions.
- Audible and visual signals for the operator.
- Inner-drum and ball bearing distributor arm work with motor and gearbox system to reduce chance of cable flip-over inside the drum.
- Main and inner drums won't rust, split or dent – ever. Cleans easily for professional appearance. Main drum holds up to 100' (30.5 m) of 3/4" (20 mm) cable, or 125' (38 m) of 5/8" (16 mm) cable.
- Powerful AUTOFEED® mechanism has grease fittings and an open design for easy maintenance. It advances and retrieves cable up to 22' (6.7 m) per minute.
- Two position stair climber eases transport and loading – to eliminate extra cost for loading wheels.
- Narrow profile lets the machine to fit through bathroom doors.
- Handles adjust to desired height to ensure balanced transport.
- Includes RIDGID® PVC drain cleaning gloves and operator's manual.
- Approved by CSA to CSA and UL Standards (115 V only).

Machine Options

| Catalog No. | Model No. | Description | Voltage | | | Weight | |
|-------------|---------------|---|---------|-----|-------|--------|------|
| | | | V | lb. | kg | | |
| 59562 | K-7500 | Machine with 3/4" (20 mm) Pigtail and Standard Accessories | 115 | 150 | 86.2 | | |
| 60052 | K-7500 C-100 | Machine, Standard Accessories, and 3/4" x 100' (20 mm x 30.5 m) Inner Core Cable. | 115 | 272 | 123.7 | | |
| 60062 | K-7500 w/C-75 | Machine, Standard Accessories, and 3/4" x 75' (20 mm 22.9 m) Inner Core Cable. | 115 | 244 | 110.9 | | |
| 61102 | K-7500 | Machine with 5/8" (16 mm) Pigtail and Standard Accessories | 115 | 149 | 67.8 | | |
| 61522 | | Machine with 5/8" (16 mm) Pigtail and Standard Accessories | 220 | | | | |
| 61542 | | Machine with 3/4" (20 mm) Pigtail and Standard Accessories | 220 | | | 150 | 86.2 |

Standard Equipment

| Catalog No. Model No. | 59562 K-7500 | 60052 K-7500 C-100 | 60062 K-7500 w/C-75 | 61102 K-7500 | 61522 K-7500 | 61542 K-7500 |
|--|-----------------|--------------------------|---------------------------|-----------------|-----------------|-----------------|
| 59360 - Tool Box | • | • | • | • | • | • |
| 69250 - 3/16" Hex Wrench | • | • | • | • | • | • |
| 70032 - RIDGID PVC Drain Cleaning Gloves | • | • | • | • | • | • |
| 92485 - P-Trap Cutter, 3" (75 mm) | • | • | • | • | • | • |
| 92495 - Spade Cutter, 1 3/4" (45 mm) | • | • | • | • | • | • |
| 92500 - Retrieving Auger 2 3/16" (65 mm) | • | • | • | • | • | • |
| 92505 - Sawtooth Cutter, 3" (75 mm) | • | • | • | • | • | • |
| 92510 - Double Cutter, 2" (50 mm) | • | • | • | • | • | • |
| 92520 - Double Cutter, 3" (75 mm) | • | • | • | • | • | • |
| 92560 - 3/4" (20 mm) x 2' (50 mm) Leader | • | • | • | • | • | • |
| 92830 - 4" Double Cutter (Blade Only) | • | • | • | • | • | • |
| 92855 - 6" Double Cutter (Blade Only) | • | • | • | • | • | • |
| 41697 - 3/4" (20 mm) x 100' IC Cable (30.5m) | | • | | | | |
| 41212 - 3/4" (20 mm) x 75' IC Cable (22.9m) | | | • | | | |

Cable Control & Performance – When Tool Engages Tough Obstructions

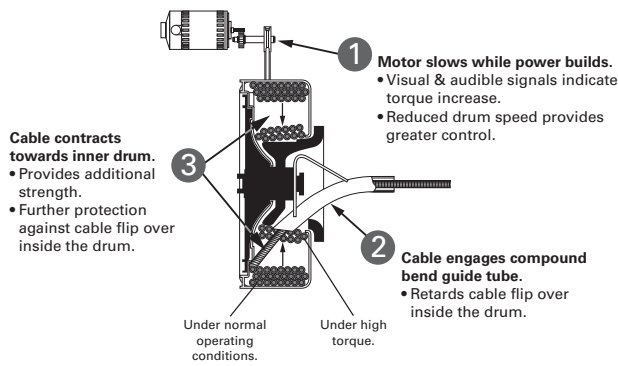

Accessories

| | Catalog No. | Model No. | Description | Weight | |
|--|-------------|-----------|--|--------|------|
| | | | | lb. | kg |
| | 41937 | - | RIDGID® Leather Drain Cleaning Gloves | 1/2 | 0.2 |
| | 41992 | A-75PF | C-100IC Kit with Tools, 3/4" (20 mm) x 100' (30.5 m) | 8 | 3.5 |
| | 49032 | | Front Guide Hose Assembly | 3 | 1.3 |
| | 59360 | A-3 | Tool Box | 5 | 2.3 |
| | 60032 | A-75PF | AUTOFEED® Assembly | 10 | 4.5 |
| | 60037 | | AUTOFEED® Spacers (4) | | |
| | 60042 | A-7534D | Drum Assembly w/3/4" (20 mm) Pigtail | 31 | 14.0 |
| | 60047 | A-75DR | Drum Only | 20 | 9.0 |
| | 61107 | A-7558D | Drum Assembly w/5/8" (16 mm) Pigtail | 30 | 13.6 |
| | 70032 | - | RIDGID® PVC Drain Cleaning Gloves | 1/2 | 0.2 |
| | 31487 | A-7570 | 5/8" (16 mm) Repair Splicer | 3/32 | 0.0 |
| | 31492 | A-7571 | 3/4" (20 mm) Repair Splicer | 1/8 | 0.1 |
| | 92805 | A-6582 | 5/8" (16 mm) Male Coupling | 1/16 | 0.0 |
| | 92810 | A-6583 | 5/8" (16 mm) Female Coupling | 1/8 | 0.1 |
| | 92880 | B-6840 | 3/4" (20 mm) Male Coupling | 1/16 | 0.0 |
| | 92885 | B-6841 | 3/4" (20 mm) Female Coupling | 1/8 | 0.1 |

Inner Core (IC) Cables

| | Catalog No. | Model No. | Description | Weight | |
|--------------|-------------|-----------|--------------------------------------|--------|------|
| | | | | lb. | kg |
| 5/8" - 16 mm | 92460 | C-25 | 5/8" (16 mm) x 25' IC Cable (7.6m) | 24 | 10.9 |
| | 92465 | C-26 | 5/8" (16 mm) x 50' IC Cable (15.2m) | 43 | 19.5 |
| | 92470 | C-27 | 5/8" (16 mm) x 75' IC Cable (22.9m) | 63 | 28.6 |
| | 43647 | C-24 | 5/8" (16 mm) x 100' IC Cable (30.5m) | 84 | 38.1 |
| 3/4" - 20 mm | 92475 | C-28 | 3/4" (20 mm) x 25' IC Cable (7.6m) | 30 | 13.9 |
| | 92480 | C-29 | 3/4" (20 mm) x 50' IC Cable (15.2m) | 60 | 27.2 |
| | 41212 | C-75 | 3/4" (20 mm) x 75' IC Cable (22.9m) | 93 | 42.5 |
| | 41697 | C-100 | 3/4" (20 mm) x 100' IC Cable (30.5m) | 122 | 55.3 |

Hollow Core Cables

| | Catalog No. | Model No. | Description | Weight | |
|--------------|-------------|-----------|---------------------------------------|--------|------|
| | | | | lb. | kg |
| 5/8" - 16 mm | 32737 | C-27HC | 5/8" (16 mm) x 75' HC Cable (23 m) | 52 3/4 | 23.9 |
| | 58192 | C-24HC | 5/8" (16 mm) x 100' HC Cable (30.5 m) | 70 1/2 | 32.1 |
| 3/4" - 20 mm | 47427 | C-75HC | 3/4" (20 mm) x 75' HC Cable (23 m) | 75 | 34.0 |
| | 47432 | z-100HC | 3/4" (20 mm) x 100' HC Cable (30.5 m) | 100 | 45.5 |

Leaders and Pig Tails

| | Catalog No. | Model No. | Description | Weight | |
|--|-------------|-----------|---|--------|-----|
| | | | | lb. | kg |
| | 92555 | T-458 | 5/8" (16 mm) x 2' (50 mm) Leader | 2 | 0.9 |
| | 92560 | T-468 | 3/4" (20 mm) x 2' (50 mm) Leader | 2 3/4 | 1.3 |
| | 44122 | - | 5/8" (16 mm) Pigtail, 4 1/2' (1.4 m) Long | 2 1/2 | 1.1 |
| | 44117 | - | 3/4" Pigtail Assembly | 3 1/2 | 1.6 |

Tools and Replacement Blades – Fit 5/8" (16 mm) and 3/4" (20 mm) Cables

| | Catalog No. | Model No. | Description | Replac. Blade(s) | Replac. Holder |
|--|-------------|-----------|----------------------------------|------------------|----------------|
| | 51762 | T-409 | H-D Bulb Auger, 1 3/4" (45 mm) | - | - |
| | 92485 | T-403 | P-Trap Cutter, 3" (75 mm) | 92835 | 92900 |
| | 92490 | T-404 | P-Trap Cutter, 3 1/2" (87 mm) | 92840 | 92900 |
| | 92495 | T-406 | Spade Cutter, 1 3/4" (45 mm) | 92850 | 92915 |
| | 92500 | T-407 | Retrieving Auger 2 9/16" (65 mm) | - | - |
| | 92505 | T-408 | Sawtooth Cutter, 3" (75 mm) | 92890 | 92915 |
| | 92510 | T-411 | Double Cutter, 2" (50 mm) | 92815 | 92905 |
| | 92515 | T-412 | Double Cutter, 2 1/2" (65 mm) | 92820 | 92905 |
| | 92520 | T-413 | Double Cutter, 3" (75 mm) | 92825 | 92910 |
| | 92525 | T-414 | Double Cutter, 4" (110 mm) | 92830 | 92910 |
| | 92530 | T-416 | Double Cutter, 6" (150 mm) | 92855 | 92910 |
| | 92535 | T-432 | 3-Blade Cutter 2" (50 mm) | 92860 | 92895 |
| | 92540 | T-433 | 3-Blade Cutter 3" (75 mm) | 92865 | 92895 |
| | 92545 | T-434 | 3-Blade Cutter 4" (110 mm) | 92870 | 92895 |
| | 92550 | T-436 | 3-Blade Cutter 6" (150 mm) | 92875 | 92895 |

C-24, C-25, C-26, C-27, C-28, C-29, C-75, C-100, C-27HC, C-24HC, C-75HC and C-100HC.

Drum Machines



K-750R DRUM MACHINE

- 3" to 6" (75 mm to 150 mm) Drain Lines
- The K-750R is a self-contained drain cleaner ideal for lateral drain lines from 3" to 6" (75 mm to 150 mm). Easy-to-transport, narrow design for small entry ways and minimal setup make this machine ideal for tough mainline work. Comes equipped with a large blade assortment to handle numerous applications. Clears roots, debris and foreign objects out of main lines, storm drains, house laterals and leach lines.
- Clear access to drum allows immediate view of cable for inspection plus easier and faster cleaning of drum and cable.
- Patented Cable Control System slows the drum, should cable or blade become completely lodged in blockage.
- New integral-wound, solid core cable is tough and kink resistant. 5/8" x 100' (16 mm x 30.5 m).
- Dual kickstands.
- New torque limiter feature.
- Lean, balanced design for easy one-man transport and operation.

SPECIFICATIONS

- **Motor** – 1/2 HP, 115V, 60Hz reversible induction motor, 200 RPM
- **Control** – Air activated foot switch

| Catalog No. | Model No. | Description | Weight | |
|-------------|-----------|--|--------|------|
| | | | lb. | kg |
| 83557 | K-750R | 5/8" (16 mm) Open Cage Drum Machine with 5/8" x 100' (16 mm x 30.5 m) IW Solid Core Cable; 2", 3", 4" "C" Cutters; P-Trap Cutter; Spade Blade; Tool Box; Gloves. | 194 | 98.0 |

Standard Equipment

| Catalog No. Model No. | 83557 K-750R |
|---|-----------------|
| 37753 - 5/8" x 100' Heavy Duty Inner Core Cable | ● |
| 59360 - Tool Box | ● |
| 92485 - P-Trap Cutter, 3" (75 mm) | ● |
| 92495 - Spade Cutter, 1 3/4" (45 mm) | ● |
| 92510 - Double Cutter, 2" (50 mm) | ● |
| 92520 - Double Cutter, 3" (75 mm) | ● |
| 92525 - Double Cutter, 4" (110 mm) | ● |

Inner Core (IC) Cables

| | Image | Catalog No. | Model No. | Description | Weight | |
|--------------|-------|-------------|-----------|--------------------------------------|--------|------|
| | | | | | lb. | kg |
| 5/8" - 16 mm | | 92460 | C-25 | 5/8" (16 mm) x 25' IC Cable (7.6m) | 24 | 10.9 |
| | | 92465 | C-26 | 5/8" (16 mm) x 50' IC Cable (15.2m) | 43 | 19.5 |
| | | 92470 | C-27 | 5/8" (16 mm) x 75' IC Cable (22.9m) | 63 | 28.6 |
| | | 43647 | C-24 | 5/8" (16 mm) x 100' IC Cable (30.5m) | 84 | 38.1 |
| 3/4" - 20 mm | | 92475 | C-28 | 3/4" (20 mm) x 25' IC Cable (7.6m) | 30 | 13.9 |
| | | 92480 | C-29 | 3/4" (20 mm) x 50' IC Cable (15.2m) | 60 | 27.2 |
| | | 41212 | C-75 | 3/4" (20 mm) x 75' IC Cable (22.9m) | 93 | 42.5 |
| | | 41697 | C-100 | 3/4" (20 mm) x 100' IC Cable (30.5m) | 122 | 55.3 |

Hollow Core Cables

| | Image | Catalog No. | Model No. | Description | Weight | |
|--------------|-------|-------------|-----------|---------------------------------------|--------|------|
| | | | | | lb. | kg |
| 5/8" - 16 mm | | 32737 | C-27HC | 5/8" (16 mm) x 75' HC Cable (23 m) | 52 3/4 | 23.9 |
| | | 58192 | C-24HC | 5/8" (16 mm) x 100' HC Cable (30.5 m) | 70 1/2 | 32.1 |
| 3/4" - 20 mm | | 47427 | C-75HC | 3/4" (20 mm) x 75' HC Cable (23 m) | 75 | 34.0 |
| | | 47432 | z-100HC | 3/4" (20 mm) x 100' HC Cable (30.5 m) | 100 | 45.5 |

Tools and Replacement Blades – Fit 5/8" (16 mm) and 3/4" (20 mm) Cables

| Image | Catalog No. | Model No. | Description | Replac. Blade(s) | Replac. Holder |
|-------|-------------|-----------|----------------------------------|------------------|----------------|
| | | | | | |
| | 92485 | T-403 | P-Trap Cutter, 3" (75 mm) | 92835 | 92900 |
| | 92490 | T-404 | P-Trap Cutter, 3 1/2" (87 mm) | 92840 | 92900 |
| | 92495 | T-406 | Spade Cutter, 1 3/4" (45 mm) | 92850 | 92915 |
| | 92500 | T-407 | Retrieving Auger 2 9/16" (65 mm) | - | - |
| | 92505 | T-408 | Sawtooth Cutter, 3" (75 mm) | 92890 | 92915 |
| | 92510 | T-411 | Double Cutter, 2" (50 mm) | 92815 | 92905 |
| | 92515 | T-412 | Double Cutter, 2 1/2" (65 mm) | 92820 | 92905 |
| | 92520 | T-413 | Double Cutter, 3" (75 mm) | 92825 | 92910 |
| | 92525 | T-414 | Double Cutter, 4" (110 mm) | 92830 | 92910 |
| | 92530 | T-416 | Double Cutter, 6" (150 mm) | 92855 | 92910 |
| | 92535 | T-432 | 3-Blade Cutter 2" (50 mm) | 92860 | 92895 |
| | 92540 | T-433 | 3-Blade Cutter 3" (75 mm) | 92865 | 92895 |
| | 92545 | T-434 | 3-Blade Cutter 4" (110 mm) | 92870 | 92895 |
| | 92550 | T-436 | 3-Blade Cutter 6" (150 mm) | 92875 | 92895 |

Leaders and Pig Tails

| Image | Catalog No. | Model No. | Description | Weight | |
|-------|-------------|-----------|---|--------|-----|
| | | | | lb. | kg |
| | 92555 | T-458 | 5/8" (16 mm) x 2' (50 mm) Leader | 2 | 0.9 |
| | 92560 | T-468 | 3/4" (20 mm) x 2' (50 mm) Leader | 2 3/4 | 1.3 |
| | 44122 | - | 5/8" (16 mm) Pigtail, 4 1/2' (1.4 m) Long | 2 1/2 | 1.1 |
| | 44117 | - | 3/4" Pigtail Assembly | 3 1/2 | 1.6 |

Accessories

| Catalog No. | Model No. | Description | Weight | |
|-------------|-----------|--|--------|------|
| | | | lb. | kg |
| 41982 | A-7534 | Drum Assembly with 3/4" (20 mm) Pigtail | 37 1/2 | 17.0 |
| 43637 | A-7558 | Drum Assembly with 5/8" (16 mm) Pigtail | 33 | 15.0 |
| 43642 | A-75 | AUTOFEED Assembly | 8 | 3.5 |
| 41937 | - | RIDGID® Leather Drain Cleaning Gloves | 1/2 | 0.2 |
| 41992 | A-75PF | C-100IC Kit with Tools, 3/4" (20 mm) x 100' (30.5 m) | 8 | 3.5 |
| 49032 | - | Front Guide Hose Assembly | 3 | 1.3 |
| 59360 | A-3 | Tool Box | 5 | 2.3 |
| 70032 | - | RIDGID® PVC Drain Cleaning Gloves | 1/2 | 0.2 |

Repair Fittings

| Image | Catalog No. | Model No. | Description | Weight | |
|-------|-------------|-----------|------------------------------|--------|------|
| | | | | lb. | kg |
| | 31487 | A-7570 | 5/8" (16 mm) Repair Splicer | 1 1/2 | 43.0 |
| | 31492 | A-7571 | 3/4" (20 mm) Repair Splicer | 2 | 57.0 |
| | 92805 | A-6582 | 5/8" (16 mm) Male Coupling | 1 | 28.0 |
| | 92810 | A-6583 | 5/8" (16 mm) Female Coupling | 2 | 57.0 |
| | 92880 | B-6840 | 3/4" (20 mm) Male Coupling | 1 | 28.0 |
| | 92885 | B-6841 | 3/4" (20 mm) Female Coupling | 2 | 57.0 |

Sectional Machines



K-50 SECTIONAL MACHINE

- 3/4" to 4" (20 mm to 110 mm) Drain Lines
- Uses sections of 5/8" (16 mm) cable, cleans 1 1/4" to 4" (32 mm to 110 mm) lines up to 100 feet.
- C-8 best for 1 1/4" to 3" (32 mm to 75 mm) drains.
- C-9 best for 2" to 4" (50 mm to 110 mm) drains.
- Equipped with an A-17 adapter for runs up to 50' (15 m) of 5/16" (8 mm) cable or, 35' (11 m) of 3/8" (10 mm) continuous length cable.
- 5/16" (8 mm) best for 3/4" (20 mm) to 1 1/2" (40 mm) lines.
- 3/8" (10 mm) best for 1 1/4" (32 mm) to 2" (50 mm) lines.
- Compact, versatile professional's machine. Capable of running three different size cables: 5/16" (8 mm), 3/8" (10 mm) and 5/8" (16 mm). The perfect, all-around sink, shower and floor drain machine. Weighs less than 40 lbs (18 kg).
- Unique, easy-to-use, instant-acting cable clutch maximizes operator control: Pull handle down and cable spins at 400 RPM. Release handle, cable stops instantly.
- Equipped with 300-watt motor.
- Includes A-1 RIDGID® drain cleaning mitt and operator's manual.
- Approved by CSA and CSA and UL Standards (115V only).

Model K-50-8 shown below includes:

- K-50 Machine
- A-17-A, Adapter includes: 25' x 5/16", C-1 Bulb Auger Cable
- A-17-B, Adapter includes: 35' x 3/8", C-5 Bulb Auger Cable
- A-1 RIDGID Drain Cleaning Mitt



Machine Options

| Catalog No. | Model No. | Description | Weight | |
|-------------|-----------|---|--------|------|
| | | | lb. | kg |
| 58920 | K-50 | Machine Only 115V | 37 | 16.8 |
| 58960 | K-50-4 | 115V Machine, with A-30 Cable Kit | 61 | 27.7 |
| 58980 | K-50-6 | 115V Machine, with -17-A Adapter, A-30 Cable Kit | 67 | 30.4 |
| 59000 | K-50-8 | 115V Machine, with A-17-A Adapter, A-17-B Adapter, A-30 Cable Kit | 77 | 34.9 |
| 52972 | K-50-9 | 115V Machine, with A-40 Cable Kit | 74 | 33.6 |
| 76455 | K-50 | Machine Only 230V | 37 | 16.8 |
| 76475 | K-50-4 | 230V Machine, with A-30 Cable Kit | 61 | 27.7 |
| 76485 | K-50-6 | 230V Machine, with -17-A Adapter, A-30 Cable Kit | 67 | 30.4 |
| 76495 | K-50-8 | 230V Machine, with A-17-A Adapter, A-17-B Adapter, A-30 Cable Kit | 77 | 34.9 |

A-30 Cable Kit Includes:

- Six Sections C-8, 7 1/2' x 5/8" Cable (45 feet).
- A-10 Cable Carrier
- T-201 Straight Auger
- T-202 Bulb Auger
- T-205 "C" Cutter
- T-211 Spade Cutter
- A-13 Coupling Pin Key
- A-14-6 Rear Guide Hose
- A-1 Left-Hand RIDGID Drain Cleaning Mitt

Cables

| | Catalog No. | Model No. | Description | Weight | |
|--------------|-------------|-----------|--|--------|-----|
| | | | | lb. | kg |
| 5/8" - 10 mm | 62265 | C-7 | 5/8" (16 mm) x 7 1/2' (2,3 m) Tight-Wind | 4 | 1.8 |
| | 62270 | C-8 | 5/8" (16 mm) x 7 1/2' (2,3 m) All-Purpose Wind | 3 | 1.4 |
| | 51317 | C-9 | 5/8" (16 mm) x 10' (3,1 m) Heavy-Duty Wind | 5 | 2.2 |
| 5/8" - 10 mm | 62245 | C-4 | 3/8" (10mm) x 25' (7,6 m) with Male Coupling | 4 1/2 | 2.0 |
| | 62250 | C-5 | 3/8" (10mm) x 35' (10,7 m) with Bulb Auger | 8 1/4 | 3.8 |
| | 62260 | C-6 | 3/8" (10 mm) x 35' (10,7 m) with Male Coupling | | |
| | 96037 | C-6IC | 3/8" (10mm) x 35' (10,7 m) Inner Core with Male Coupling | 8 1/2 | 4.0 |
| 5/8" - 8 mm | 62225 | C-1 | 5/16" (8 mm) x 25' (7.6 m) with Bulb Auger | 3 1/2 | 1.6 |
| | 56782 | C-1IC | 5/16" (8 mm) x 25' (7.6 m) Inner Core with Bulb Auger | 4 | 1.8 |
| | 89400 | C-21 | 5/16" (8 mm) x 50' (15,2 m) with Bulb Auger | 7 | 3.2 |
| | 62235 | C-2 | 5/16" (8 mm) x 25' (7,6 m) with Drop Head Auger | 3 1/2 | 1.6 |
| | 56787 | C-2IC | 5/16" (8 mm) x 25' (7.6 m) Inner Core with Drop Head Auger | 4 | 1.8 |
| | 89405 | C-22 | 5/16" (8 mm) x 50' (15,2 m) with Drop Head Auger | 7 | 3.2 |

Cable Kits

| | Catalog No. | Model No. | Cable | Tools & Accessories | Weight | |
|--|-------------|-----------|--|---|--------|------|
| | | | | | lb. | kg |
| | 59365 | A-30 | Six Sections: C-8, 5/8"x7 1/2' (45', 13,7 m) | T-201 Straight Auger T-202 Bulb Auger T-205 "C" Cutter T-211 Spade Cutter A-13 Coupling Pin Key A-10 Cable Carrier A-14-6 Rear Guide Hose A-1 Left-Hand RIDGID Drain Cleaning Mitt | 20 | 9.1 |
| | 52962 | A-40 | Six Sections: C-9, 5/8" x 10' (60', 18,3 m) | T-206 Funnel Auger T-215 4-Blade Cutter T-231 "C" Cutter A-13 Coupling Pin Key A-10 Cable Carrier A-14-10 Rear Guide Hose A-1 Left-Hand RIDGID Drain Cleaning Mitt | 37 | 16.8 |
| | 59370 | A-30TW | Six Sections: C-7, 5/8"x7 1/2' (45', 13,7m) Tight-Wind | Same as A-30 | 30 | 13.6 |

Adapters

| | Catalog No. | Model No. | Description | Weight | |
|--|-------------|-----------|---|--------|-----|
| | | | | lb. | kg |
| | 59250 | A-17-A | Adapter With 25' (7,6 m) x 5/16" (8 mm) Cable w/Bulb Auger | 8 | 3.6 |
| | 59255 | A-17-B | Adapter With 35' (10,7 m) x 3/8" (10 mm) Cable w/Bulb Auger | 13 | 5.9 |
| | 59265 | A-17-C | Adapter With 35' x 3/8" Cable w/Male Coupling | | |
| | 92095 | A-17-D | Adapter With 50' x 5/16" Cable w/Bulb Auger | 12 | 5.4 |
| | 92100 | A-17-E | Adapter With 25' x 5/16" Cable w/Drop Head | | |

Accessories

| | Catalog No. | Model No. | Description | Weight | |
|--|-------------|-----------|---|--------|-----|
| | | | | lb. | kg |
| | 59235 | A-14-6 | 6' (1,8 m) Rear Guide Hose | 5 | 2.3 |
| | 84325 | A-14-10 | 10' (3 m) Rear Guide Hose | 7 | 3.2 |
| | 59270 | A-18 | Front Guide Hose Assembly | 9 | 4.1 |
| | 59210 | A-10 | Cable Carrier Holds 90' (27 m) C-8, C-9 | 3 1/4 | 1.5 |
| | 59205 | A-1 | Left-Hand RIDGID Drain Cleaning Mitt | 1/2 | 0.2 |
| | 59295 | A-2 | Right-Hand RIDGID Drain Cleaning Mitt | | |
| | 59230 | A-13 | 3/8" Cable Pin Key | | |
| | 59450 | A-3179 | A-3179 Clutch Jaw Assembly | 1 1/2 | 0.7 |

Tools

| | Catalog No. | Model No. | Description | Replac. Blade(s) |
|--|-------------|-----------|--|------------------|
| | 62990 | T-201 | Straight Auger, 5" (125 mm) Long | |
| | 62067 | T-201A | Straight Flex Auger | |
| | 62995 | T-202 | Bulb Auger, 1 1/8" (29 mm) O.D. | |
| | 63000 | T-203 | Bulb Auger 7/8" (22 mm) O.D. | |
| | 54837 | T-204 | "C" Cutter 1" (25 mm) | 54832 |
| | 63005 | T-205 | "C" Cutter, 1 3/8" (35 mm) | 97835 |
| | 52812 | T-230 | H-D "C" Cutter, 2" (50 mm) | 92815 |
| | 52817 | T-231 | H-D "C" Cutter, 2 1/2" (65 mm) | 92820 |
| | 52822 | T-232 | H-D "C" Cutter, 3" (80 mm) | 92835 |
| | 63010 | T-206 | Funnel Auger, 3" (80 mm) Long | - |
| | 63015 | T-207 | Spiral Cutter, 1 1/4" (32 mm) | 97840 |
| | 63020 | T-208 | Spiral Cutter, 1 1/2" (40 mm) | 97895 |
| | 63025 | T-209 | Spiral Cutter, 2" (50 mm) | 97900 |
| | 63030 | T-210 | Spade Cutter, 1" (25 mm) | 97905 |
| | 63035 | T-211 | Spade Cutter, 1 3/8" (35 mm) | 97825 |
| | 63040 | T-212 | Spade Cutter, 1 3/4" (45 mm) | 92850 |
| | 63045 | T-213 | 4-Blade Cutter, 1" (25 mm) | 97795 |
| | 63050 | T-214 | 4-Blade Cutter, 1 3/8" (35 mm) | 97910 |
| | 63055 | T-215 | 4-Blade Cutter, 1 3/4" (45 mm) | 97915 |
| | 63060 | T-216 | Chain Knocker, 2" (50 mm) | 98000 |
| | 63065 | T-217 | Drop Head Auger, 4" (110 mm) Long | |
| | 63280 | T-218 | Flue Brush, 3" (75 mm) | |
| | 63070 | T-219 | Flue Brush, 2 1/2" (65 mm) | |
| | 63080 | T-220 | Flue Brush, 2" (50 mm) | |
| | 63220 | T-221 | Flue Brush, 1 1/2" (40 mm) | |
| | 55457 | T-225 | Retrieving Auger | |
| | 12128 | T-240 | Tool Set (5/8"- K-380): T-202 Bulb Auger, T-211 Spade Cutter, A-13 Pin Key | |
| | 48482 | T-250 | Tool Set includes: T-203, T-205, T-210, T-217, A-13 | |

Sectional Machines



K-60SP SECTIONAL MACHINE

- 1 1/4" to 4" (32-100 mm) Drain Lines
- Simple adjustment knob allows unit to spin both 7/8" (22 mm) and 5/8" (16 mm) diameter cable. Adjusts in seconds.
- 7/8" (22 mm) cable (C-10) cleans 2" to 4" (50 mm to 100 mm) lines through 150' 45.7 m).
- 5/8" (16 mm) cable (C-7, C-8, C-9) cleans 1 1/4" to 4" (32 mm to 100 mm) lines through 125' (38.1 m).
- A compact machine for institutional, commercial or residential cleaning. Also ideal for septic tank vacuum truck operators. Small enough to fit into cramped spaces, yet powerful enough to clear tough blockages.
- Ideal for rooftop vent stacks. Rear handle allows for easy transporting up ladders and onto rooftops.
- Remove only two bolts to access jaw set for cleaning or replacement. Removal of same bolts provides access to belt drive.
- Equipped with 1/2 HP motor. CSA approved. Approved to UL standards (NRTL).

Machine Options

| Catalog No. | Model No. | Description | Weight | |
|-------------|-----------|--|--------|------|
| | | | lb. | kg |
| 66492 | K-60SP | Machine with A-1 Operator's Mitt, A-12 Pin Key, and A-60-12 Rear Guide Hose | 41 | 18.6 |
| 66497 | K-60SP-SE | Machine with A-1 Operator's Mitt, A-12 Pin Key, and A-60-12 Rear, Guide Hose, plus: A-61 Tool Kit and A-62 Cable Kit | 92 | 41.7 |
| 66512 | K-60SP | Machine with A-1 Operator's Mitt, A-12 Pin Key, and A-60-12 Rear Guide Hose | 41 | 18.6 |
| 66517 | K-60SP-SE | Machine with A-1 Operator's Mitt, A-12 Pin Key, and A-60-12 Rear, Guide Hose, plus: A-61 Tool Kit and A-62 Cable Kit | 92 | 41.7 |

K-60SP-SE shown below includes:

- K-60SP Machine
- A-1 RIDGID® Drain Cleaning Mitt
- A-60-12 Rear Guide Hose
- A-62 Cable Kit, includes:
 - A-8 Cable Carrier
 - Five Sections Of C-10, 7/8" Cable, Total 75 Feet
- A-61 Tool Kit, includes:
 - T-101 Straight Auger
 - T-102 Funnel Auger
 - T-107 Spade Cutter
 - T-125 Retrieving Auger
 - T-150-1 Sharktooth Cutter
 - A-3 Tool Box
 - A-12 Pin Key



Cables and Leaders

| | Catalog No. | Model No. | Description | Weight | |
|------------|-------------|-----------|--|--------|-----|
| | | | | lb. | kg |
| 7/8" 22 mm | 62275 | C-10 | 7/8" (22 m) x 15' (4,6 m) All- Purpose Wind Requires A-368-X Jawset | 9 1/2 | 4.3 |
| | 25036 | C-10 PC | 7/8" (22 mm) x 15' Cable with Inner Core (4,6 m) Requires A-368-X Jawset | 10 | 4.5 |
| | 30007 | T-127 | 7/8" (22 mm) Trap Leader | 2 | 0.9 |
| 5/8" 16 mm | 51317 | C-9 | 5/8" (16 mm) x 10' (3,1 m) Heavy-Duty Wind | 5 | 2.2 |
| | 62270 | C-8 | 5/8" (16 mm) x 7 1/2' (2,3 m) All-Purpose Wind | 3 | 1.4 |
| | 62265 | C-7 | 5/8" (16 mm) x 7 1/2' (2,3 m) Tight-Wind | 4 | 1.8 |

Cable Kits and Tool Kits

| Image | Catalog No. | Model No. | Description | Weight | |
|-------|-------------|-----------|--|--------|------|
| | | | | lb. | kg |
| | 61625 | A-62 | Standard Equipment Tool Kit for K-60-SE, includes: -T-101 Straight Auger -T-102 Funnel Auger -T-107 Spade Cutter -T-125 Retriving Auger -T-150-1 Sharktooth Cutter -A-3 Tool Box -A-12 Pin Key | 43 | 19.5 |
| | 61630 | A-61 | Standard Equipment Cable Kit for K-60-SE, includes: - Five Sections C-10, 7/8" (22 mm) x 15' (4,6 m) Cable - A-8 Cable Carrier | 8 | 3.6 |
| | 48472 | A-35 | 5/8" Cable Kit, includes: Six Sections C-8, 5/8" x 7 1/2" Cable (45', 14m), A-10 Cable Carrier, T-201 Straight Auger, T-202 Bulb Auger, T-205 "C" Cutter, T-211 Spade Cutter, A-13 Coupling Pin Key | 18 | 8.2 |
| | 48477 | A-35TW | 5/8" Tight-Wind Cable Kit, Substitutes C-7 For C-8 In, Above Package | - | - |
| | 59365 | A-30 | Six Sections: C-8, 5/8"x7 1/2" (45', 13,7 m) | 20 | 9.1 |
| | 94492 | A-25 | 5/8" (16 mm) Cable Kit, includes: Five Sections C-8, 5/8" (16 mm) x 7 1/2" (2,3 m) Cable 37.5' (11,5 m) -A-10 Cable Carrier -T-201 Straight Auger -T-202 Bulb Auger -T-205 "C" Cutter -A-13 Coupling Pin Key | 18 | 8.2 |

Accessories

| Image | Catalog No. | Model No. | Description | Weight | |
|-------|-------------|-----------|--|--------|-----|
| | | | | lb. | kg |
| | 59360 | A-3 | Tool Box | 5 | 2.3 |
| | 59205 | A-1 | Left-Hand RIDGID Drain Cleaning Mitt | 1/2 | 0.2 |
| | 59295 | A-2 | Right-Hand RIDGID Drain Cleaning Mitt | | |
| | 59230 | A-13 | 3/8" Cable Pin Key | | |
| | 59225 | A-12 | 1/2" Cable Pin Key | 1/2 | 0.2 |
| | 61615 | A-60-12 | 12' (3,7 m) Rear Guide Hose For K-60 | 12 | 5.5 |
| | 76575 | A-60-16 | 16' (4,9 m) Rear Guide Hose For K-60 | 15 1/2 | 7.0 |
| | 59425 | A-36 | Cable Caddy | 15 | 6.8 |
| | 59210 | A-10 | Cable Carrier Holds 90' (27 m) C-8, C-9 | 3 1/4 | 1.5 |
| | 59470 | A-8 | Cable Carrier 60' (18 m) Capacity 1 1/4" (32 mm) | 5 1/2 | 2.5 |
| | 59445 | A-5 | Grease Gun | 1/2 | 0.2 |
| | 65687 | | Clutch Jaw | 3/4 | 0.3 |

Tools - Fits 7/8" Sectional Cables

| Image | Catalog No. | Model No. | Description | Replac. Blade(s) |
|-------|-------------|-----------|--|-------------------------------------|
| | 62850 | T-101 | Straight Auger | |
| | 62855 | T-102 | Funnel Auger | - |
| | 27642 | T-125 | Straight Retrieving Auger | |
| | 62860 | T-103 | Sawtooth Cutter, 2 1/2" (65 mm) | 98070 |
| | 62865 | T-104 | "H" Cutter, 2 1/2" (65 mm) | 97800 |
| | 62870 | T-105 | Grease Cutter, 2 1/2" (65 mm) | 97920 |
| | 62875 | T-106 | Grease Cutter, 3 1/2" (87 mm) | 97925 |
| | 62915 | T-109 | Spiral Sawtooth Cutter, 1 1/2" (45 mm) | 97930 |
| | 62920 | T-110 | Spiral Sawtooth Cutter, 2 1/4" (57 mm) | 97935 |
| | 62925 | T-111 | Spiral Sawtooth Cutter, 3" (75 mm) | 92890 |
| | 62930 | T-112 | 4-Blade Cutter, 1 3/4" (45 mm) | 97915 |
| | 62935 | T-113 | 4-Blade Cutter, 3" (75 mm) | 97910 |
| | 62940 | T-114 | Chain Knocker for 4" lines | 97985 |
| | 98050 | T-150 | Sharktooth Cutter 3" (75 mm) and 4" (110 mm) | - |
| | 98055 | T-150-1 | Sharktooth Cutter 3" (75 mm) Blade | 98005- 3" (75mm)/ 98010- 3" (100mm) |
| | 98060 | T-150-2 | Sharktooth Cutter 4" (110 mm) Blade | 98010 |
| | 62880 | T-107 | Spade Cutter, 1 3/4" (45 mm) | 92850 |
| | 54842 | T-141 | Knife Blade Cutter 1 1/2" (40 mm) | 54847 |
| | 54852 | T-142 | Knife Blade Cutter 2 1/2" (65 mm) | 97800 |

FAST, SIMPLE METHOD TO CONNECT TOOLS

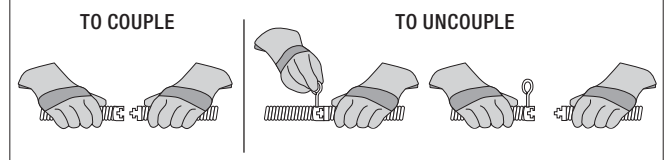

For C-4, C-6, C-7, C-8, C-9, C-10, C-11, C-12, C-14, C-15, C-31, C-32, C-33, C-44, C-45, and C-46.

Sectional Machines

Model K-1500A
(A-Frame)



Model K-1500B
(B-Frame)



Model K-1500 B W/C-11 shown above includes:

- K-1500 B Machine with A-1 RIDGID® Drain Cleaning Mitt, A-12 Pin Key and A-34-12 Rear Guide Hose
- Seven Sections of 1 1/4" (C-11) Cable, Total 105 Feet
- Two A-8 Cable Carriers
- Nine-Piece Tool Set includes:
 - T-1 Straight Auger
 - T-3 Funnel Auger
 - T-6 Retrieving Auger
 - A-3516 Hex Key
 - T-13 Sawtooth Cutter
 - T-50-1 Sharktooth Cutter
 - A-2864 Hex Key
 - T-8 Grease Cutter
 - A-3 Tool Box

K-1500 SECTIONAL MACHINE

- 2" to 8" (50 mm to 200 mm) Drain and Sewer Lines
- The finest all-around sewer and drain cleaning machine. One man can easily clean the heaviest blockages – indoors or out. High-speed cleaning gets the job done faster and better.
- Wheels to the job site – sets up fast, cleans up fast.
- Low-profile "B" frame design will fit most crawl spaces. Loads and unloads from truck easily. Upright "A" frame features cable carrier storage during transport, ideal for in-house applications.
- Equipped to run, easy to handle, 15' (4.6 m) sections of 1 1/4" (32 mm) cable to clean 3" to 8" (32 m to 200 mm) lines to 200' (61 m).
- Easy clutch jaw change-out adapts K-1500 to run 15' (4.6) sections of 7/8" (22 mm) cable through 2" to 4" (50 to 100 mm) lines up to 175' (53 m).
- Equipped with 3/4 HP motor. CSA approved. Approved to UL standards (NRTLCL).









Machine Options – A Frame

| Catalog No. | Model No. | Description | Weight | |
|-------------|-----------|--|--------|-------|
| | | | lb. | kg |
| 23692 | | Machine with A-1 Mitt, A-12 Pin Key, and Rear Guide Hose | 135 | 61.3 |
| 23702 | | Machine with A-1 Mitt, A-12 Pin Key, and A-34-12 Rear Guide Hose, Plus: Seven Sections 1 1/4" (32 mm) (C-14) Cable, Total 105 Feet, Two A-8 Cable Carriers, Nine-Piece 1 1/4" Tool Set | | |
| 23712 | K-1500A | Machine with A-1 Mitt, A-12 Pin Key, and A-34-12 Rear Guide Hose, Plus: Seven Sections 1 1/4" (32 mm) (C-14) Cable, Total 105 Feet, Two A-8 Cable Carriers, Nine-Piece 1 1/4" Tool Set | 256 | 116.1 |
| 27592 | | Machine with A-1 Mitt, A-12 Pin Key, and A-34-12 Rear Guide Hose, Plus: Seven Sections 1 1/4" (32 mm) (C-11) Cable, Total 105 Feet, Two A-8 Cable Carriers, Nine-Piece 1 1/4" Tool Set | | |
| 27612 | | Machine with A-1 Mitt, A-12 Pin Key, and Rear Guide Hose | 135 | 61.3 |



Machine Options – B Frame

| Catalog No. | Model No. | Description | Weight | |
|-------------|---------------------|---|--------|-------|
| | | | lb. | kg |
| 23697 | | Machine with A-1 Mitt, A-12 Pin Key, and A-34-12 Rear Guide Hose | 135 | 61.3 |
| 23707 | | Machine with A-1 Mitt, A-12 Pin Key, and A-34-12 Rear Guide Hose, Plus: Seven Sections 1 1/4" (32 m) (C-14) Cable Total 105' (32 m), Two A-8 Cable Carriers, Nine-Piece 1 1/4" Tool Set | | |
| 23717 | K-1500B | Machine with A-1 Mitt, A-12 Pin Key, and A-34-12 Rear Guide Hose, Plus: Seven Sections 1 1/4" (32 m) (C-11) Cable, Total 105' (32 m), Two A-8 Cable Carriers, Nine-Piece 1 1/4" Tool Set | 256 | 116.1 |
| 27597 | | Machine with A-1 Mitt, A-12 Pin Key, and A-34-12 Rear Guide Hose, Plus: Seven Sections 1 1/4" (32 m) (C-11) Cable, Total 105' (32 m), Two A-8 Cable Carriers, Nine-Piece 1 1/4" Tool Set | | |
| 27617 | | Machine with A-1 Mitt, A-12 Pin Key, and A-34-12 Rear Guide Hose | 135 | 61.3 |
| 27637 | | Machine with A-1 Mitt, A-12 Pin Key, and A-34-12 Rear Guide Hose, Plus: Seven Sections 1 1/4" (32 mm) (C-11) Cable, Total 105' (32 m), Two A-8 Cable Carriers, Nine-Piece 1 1/4" Tool Set | 256 | 116.1 |
| 33922 | K-1500B Special Kit | Machine with A-1 Mitt, A-12 Pin Key, A-34-12 Rear Guide Hose, four Sections 1 1/4" (32mm) (C11) Cable, Total 60' (18m), one A-8 Cable Carrier, T-3 funnel auger, T-50-1 shark tooth cutter and hex key. | 210 | 95.0 |

Cables and Leaders

| | Catalog No. | Model No. | Description | Weight | | |
|---|---|---|-------------|--|---|-------|
| | | | | lb. | kg | |
| 1 1/4" - 32 mm |  | 62280 | C-11 | 1 1/4" (32 mm) x 15' (4.6 m) Standard All-Purpose Wind. 3/8" (10 mm) Pitch. Good for 4" (110 mm) Traps, 3" (75 mm) - 8" (200 mm) Lines | 16 | 7.3 |
| |  | 24226 | C-11 PC | 15' (4.6 m) Standard All-Purpose Wind 3/8" Pitch with Plastic Core, Good For 4" Traps | 17 3/5 | 8.0 |
| |  | 62285 | C-12 | 15' (4.6 m) Extra-Heavy-Duty Wind. 3/8" (10 mm) Pitch. Recommended For 4" (110 mm) - 10" (250 mm) Long Runs, No 4" (110 mm) Traps | 19 | 8.6 |
| |  | 62295 | C-14 | 15' (4.6) Heavy-Duty Wind. 1/2" (13 mm) Pitch. Recommended For 3" (75 mm) - 10" (250 mm) Lines Through Cleanout, No 4" (110 mm) Traps | 16 | 6.8 |
| |  | 62300 | C-15 | 15' (4.6) Extra-Flexible Wind. 1/2" (13 mm) Pitch. Recommended For 3" (75 mm) - 6" (150 mm) Lines Good for Traps | 12 | 5.5 |
| |  | 63090 | T-27 | 1 1/4" (32 mm) x 25" (63.5 cm) Leader | 2 3/4 | 1.2 |
| | 7/8" - 22 mm |  | 62275 | C-10 | 7/8" (22 mm) x 15' (4.6 m) All-Purpose Wind Requires A-368-X Jawset | 9 1/2 |
|  | | 25036 | C-10 PC | 7/8" (22 mm) x 15' Cable with Inner Core (4.6 m) Requires A-368-X Jawset | 10 | 4.5 |

Cable Kits

| | Catalog No. | Model No. | Description | Weight | |
|---|-------------|-----------|--|--------|------|
| | | | | lb. | kg |
|  | 61630 | A-61 | Standard Equipment Cable Kit for K-60-SE, includes: - Five Sections C-10, 7/8" (22 mm) x 15' (4.6 m) Cable - A-8 Cable Carrier | 8 | 3.6 |
|  | 61625 | A-62 | Standard Equipment Tool Kit for K-60-SE, includes: -T-101 Straight Auger -T-102 Funnel Auger -T-107 Spade Cutter -T-125 Retriving Auger -T-150-1 Sharktooth Cutter -A-3 Tool Box -A-12 Pin Key | 43 | 19.5 |

Accessories

| | Catalog No. | Model No. | Description | Weight | |
|---|-------------|-----------|---|--------|------|
| | | | | lb. | kg |
|  | 59205 | A-1 | Left-Hand RIDGID Drain Cleaning Mitt | 1/2 | 0.2 |
|  | 59295 | A-2 | Right-Hand RIDGID Drain Cleaning Mitt | | |
|  | 59225 | A-12 | 1/2" Cable Pin Key | | |
|  | 59240 | A-17 | Manhole Guide Pipe | 23 | 10.4 |
|  | 59300 | A-20 | 8-Foot (2,4 m) Front Guide Hose Assembly | 25 | 11.4 |
|  | 59320 | A-369X | 1 1/4" Jaw Assembly | 3/4 | 0.3 |
| | 59325 | A-368X | 7/8" Jaw Assembly | | |
|  | 59360 | A-3 | Tool Box | 5 | 2.3 |
|  | 59395 | A-34-12 | 12-Foot (3,7 m) Rear Guide Hose | 20 | 9.1 |
| | 59400 | A-34-16 | 16-Foot (4,9 m) Rear Guide Hose | 26 1/2 | 12.0 |
| | 59415 | A-34-10 | 10-Foot (3,1 m) Rear Guide Hose | 13 3/8 | 6.2 |
|  | 59440 | A-4 | Trap Spoon (30", 76 cm) | 1 3/4 | 0.8 |
|  | 59470 | A-8 | Cable Carrier 60' (18 m) Capacity 1 1/4" (32 mm) | 5 1/2 | 2.5 |
| | 59475 | A-9 | Cable Carrier 150-Foot (45,7) Capacity 1 1/4" (32 mm) | 14 | 6.4 |
|  | 62467 | A-1HD | Heavy-Duty Left-Hand RIDGID Drain Cleaning Mitt | 1/2 | 0.2 |
|  | 62472 | A-2HD | Heavy-Duty Right-Hand RIDGID Drain Cleaning Mitt | | |

Tools

| | Catalog No. | Model No. | Description | Replac. Blade(s) |
|---|-------------|-----------|--|------------------|
| | | | | |
|  | 59480 | T-11 | "H" Cutter, 2 1/2" (65 mm) | 97800 |
|  | 59485 | T-12 | "H" Cutter, 3 1/2" (89 mm) | 97945 |
|  | 61770 | T-15A | Expanding Cutter, 4" - 6" (110-150 mm) | 62970 |
|  | 61790 | T-4 | Heavy-Duty Funnel Auger | - |
|  | 61800 | T-2 | Heavy-Duty Straight Auger | - |
|  | 61825 | T-15B | Expanding Cutter, 6" - 8" (150-200 mm) | 62980 |
|  | 61970 | T-13 | Sawtooth Cutter, 2 1/2" (65 mm) | 98070 |
|  | 61975 | T-14 | Sawtooth Cutter, 3 1/2" (89 mm) | 98075 |
|  | 62840 | T-1 | Straight Auger | - |
|  | 62845 | T-10 | Grease Cutter, 4 1/2" (114 mm) | 97865 |
|  | 63105 | T-3 | Funnel Auger | - |
|  | 63190 | T-5 | A-3565 Key | - |
|  | 63195 | T-6 | Funnel Retrieving Auger Run Machine In Reverse | - |
|  | 63200 | T-7 | Hook Auger | - |
|  | 63205 | T-8 | Grease Cutter, 2 1/2" (65 mm) | 97920 |
|  | 63210 | T-9 | Grease Cutter, 3 1/2" (89 mm) | 97925 |
|  | 59625 | T-21 | Spiral Sawtooth Cutter, 2 1/2" (65 mm) | 97970 |
|  | 59765 | T-24 | 4-Blade Cutter, 2 1/2" (65 mm) | 97940 |
|  | 59770 | T-25 | 4-Blade Cutter, 3 1/2" (89 mm) | 97975 |
|  | 59775 | T-26 | 4-Blade Cutter, 4 1/2" (114 mm) | 97805 |
|  | 59780 | T-26A | 4-Blade Cutter, 5 1/2" (140 mm) | 97980 |
|  | 61850 | T-17 | Spiral Bar Cutter, 6" (150 mm) | 97955 |
|  | 61855 | T-18 | Spiral Bar Cutter, 8" (200 mm) | 97960 |
|  | 61960 | T-16 | Spiral Bar Cutter, 4" (110 mm) | 97855 |
|  | 63075 | T-22 | Spiral Sawtooth Cutter, 3" (75 mm) | 97970 |
|  | 63085 | T-23 | Spiral Sawtooth Cutter, 4" (110 mm) | 97850 |
|  | 63110 | T-31 | Chain Knocker, For 3"- 4" Pipe (75-110 mm) | 97985 |
|  | 63115 | T-32 | Chain Knocker, For 6" Pipe (150 mm) | 97990 |
|  | 63120 | T-33 | Chain Knocker, For 8" Pipe (200 mm) | 97995 |
|  | 63145 | T-38 | Flue Brush, 1 1/2" (40 mm) | - |
|  | 63150 | T-39 | Flue Brush, 2" (50 mm) | - |
|  | 63155 | T-40 | Flue Brush, 2 1/2" (65 mm) | - |
|  | 63160 | T-41 | Flue Brush, 3" (76 mm) | - |
|  | 63165 | T-42 | Flue Brush, 3 1/2" (89 mm) | - |
|  | 63170 | T-43 | Flue Brush, 4" (110 mm) | - |
|  | 63175 | T-44 | Flue Brush, 4 1/2" (114 mm) | - |
| | 63180 | T-46 | Flue Brush, 5 1/2" (140 mm) | - |
| | 63185 | T-47 | Flue Brush, 6" | - |
| | 63240 | T-45 | Flue Brush, 5" (127 mm) | - |
| | 98030 | T-50 | Includes 3 Sizes: 3-4-5" (75-110-127 mm) | - |
| | 98035 | T-50-1 | Sharktooth Cutter, 3" (75 mm) | 98005 |
| | 98040 | T-50-2 | Sharktooth Cutter, 4" (110 mm) | 98010 |
| | 98045 | T-50-3 | Sharktooth Cutter, 5" (127 mm) | 98015 |

Sectional Machines



K-1500SP SECTIONAL MACHINE

- 2" to 10" (50 mm to 250 mm) Drain and Sewer Lines.
- The finest all-around sewer and drain cleaning machine. One man can easily clean the heaviest blockages – indoors or out. High-speed cleaning gets the job done faster and better.
- Unique, easy-to-use, instant-acting cable clutch maximizes operator control: Pull handle down and cable spins at 600 RPM Release handle, cable stops instantly.
- Wheels to the job site – sets up fast, cleans up fast.
- Equipped to run, easy to handle, 15' (4.6 m) sections of 1 1/4" (32 mm) cable to clean 3" (75 mm) to 10" (250 mm) lines to 300' (91 m).
- Easy clutch jaw change-out adapts K-1500 to run 15' (4.6 m) sections of 7/8" (22 mm) cable through 2" (50 mm) to 4" (110 mm) lines up to 175' (53 m).
- Equipped with full 1500-watt motor and heavy-duty rotary switch.
- 10" solid ball bearing wheels.
- Low profile frame design will fit most crawl spaces.
- Includes A-1 RIDGID® drain cleaning mitt and operators manual.
- Approved by CSA to CSA and UL Standards (115V only).

Model K-1500SP with C-11 shown below

- K-1500SP w/C-11 includes:
K-1500SP Machine with A-1 RIDGID Drain Cleaning Mitt and A-12 Pin Key
- A-34-12 Rear Guide Hose
- 150 Feet, Ten Sections of C-11, 1 1/4" Cable
- Three A-8 Cable Carriers
- Nine-Piece 1 1/4" Tool Package, includes:
 - T-1 Straight Auger
 - T-3 Funnel Auger
 - T-6 Retrieving Auger
 - T-8 2 1/2" Grease Cutter
 - T-13 2 1/2" Sawtooth Cutter
 - T-50 Sharktooth Cutter with 3", 4" and 5" Blades
 - A-2864 Hex Key (3/16")
 - A-3 Tool Box
 - A-3516 Hex Key (1/4")

Machine Options – B Frame

| Catalog No. | Model No. | Description | Weight | |
|-------------|------------|--|--------|-------|
| | | | lb. | kg |
| 43507 | | 120V-60Hz Machine with A-1 Operator's Mitt and A-12 Pin Key, Plus: A-34-12 Rear Guide Hose | 141 | 64.0 |
| 46907 | K-1500SP | 120V-60Hz Machine with A-1 Operator's Mitt and A-12 Pin Key, Plus: A-34-12 Rear Guide Hose, A-34-12 Rear Guide Hose, 150' (45.7m), Ten Sections of C-11, 1 1/4" (32 mm) Cable, Three A-8 Cable Carriers, A-3 Tool Box, Eight-Piece 1 1/4" (32 mm) Tool Package | 317 | 144.0 |
| 91027 | K-1500SPB | 120V-60Hz Machine with A-1 RIDGID Drain Cleaning Mitt and A-12 Pin Key Plus : - A-34-12 Rear Guide Hose - C-14 Three Carrier Cable Combination Kit | 297 | 135.0 |
| 43512 | K-1500SP-B | 240V-50Hz Machine with A-1 Operator's Mitt and A-12 Pin Key, Plus: A-34-12 Rear Guide Hose | 141 | 64.0 |

Machine Options - A Frame

| Catalog No. | Model No. | Description | Weight | |
|-------------|------------|--|--------|-------|
| | | | lb. | kg |
| 46837 | | 120V Machine with A-1 Operator's Mitt and A-12 Pin Key, Plus: A-34-12 Rear Guide Hose | 150 | 68.0 |
| 46902 | K-1500SPA | 120V Machine with A-1 Operator's Mitt and A-12 Pin Key, Plus: A-34-12 Rear Guide Hose, A-34-12 Rear Guide Hose, 150' (45.7), Ten Sections of C-11, 1 1/4" (32 mm) Cable, Three A-8 Cable Carriers, A-3 Tool Box, Eight-Piece 1 1/4" (32 mm) Tool Package | 326 | 148.0 |
| 91032 | | 120V Machine with A-1 Operator's Mitt and A-12 Pin Key, Plus: A-34-12 Rear Guide Hose & C-14 Three Carrier Cable Combination Kit | 317 | 144.0 |
| 45317 | K-1500SP-A | Machine with A-1 RIDGID Drain Cleaning Mitt, A-12 Pin Key, and A-34-12 Rear Guide Hose, Plus SE Tool Kit (see below). | 254 | 120.0 |



Model K-1500SP with C-11 shown above.

Cables and Leaders

| Image | Catalog No. | Model No. | Description | Weight | |
|-------|-------------|-----------|--|------------------|-----|
| | | | | lb. | kg |
| | 24226 | C-11 PC | 15' (4,6 m) Standard All- Purpose Wind $\frac{3}{8}$ " Pitch with Plastic Core. Good For 4" Traps | 17 $\frac{3}{5}$ | 8.0 |
| | 25036 | C-10 PC | $\frac{7}{8}$ " (22 mm) x 15' Cable with Inner Core (4,6 m) Requires A-368-X Jawset | 10 | 4.5 |
| | 62275 | C-10 | $\frac{7}{8}$ " (22 mm) x 15' (4,6 m) All- Purpose Wind Requires A-368-X Jawset | 9 $\frac{1}{2}$ | 4.3 |
| | 62280 | C-11 | 1 $\frac{1}{4}$ " (32 mm) x 15' (4,6 m) Standard All-Purpose Wind. $\frac{3}{8}$ " (10 mm) Pitch. Good for 4" (110 mm) Traps, 3" (75 mm) - 8" (200 mm) Lines | 16 | 7.3 |
| | 62285 | C-12 | 15' (4,6 m) Extra-Heavy- Duty Wind. $\frac{3}{8}$ " (10 mm) Pitch. Recommended For 4" (110 mm) - 10" (250 mm) Long Runs, No 4" (110 mm) Traps | 19 | 8.6 |
| | 62295 | C-14 | 15' (4,6) Heavy-Duty Wind. $\frac{1}{2}$ " (13 mm) Pitch. Recommended For 3" (75 mm) - 10" (250 mm) Lines Through Cleanout, No 4" (110 mm) Traps | 16 | 6.8 |
| | 62300 | C-15 | 15' (4,6) Extra-Flexible Wind. $\frac{1}{2}$ " (13 mm) Pitch. Recommended For 3" (75 mm) - 6" (150 mm) Lines Good for Traps | 12 | 5.5 |
| | 63090 | T-27 | 1 $\frac{1}{4}$ " (32 mm) x 25" (63,5 cm) Leader | 2 $\frac{3}{4}$ | 1.2 |

Cable Kits and Tool Kit

| Image | Catalog No. | Model No. | Description | Weight | |
|-------|-------------|-----------|--|--------|------|
| | | | | lb. | kg |
| | 61630 | A-61 | Standard Equipment Cable Kit for K-60-SE, includes: - Five Sections C-10, $\frac{7}{8}$ " (22 mm) x 15' (4,6 m) Cable - A-8 Cable Carrier | 8 | 3.6 |
| | 61625 | A-62 | Standard Equipment Tool Kit for K-60-SE, includes: -T-101 Straight Auger -T-102 Funnel Auger -T-107 Spade Cutter -T-125 Retriving Auger -T-150-1 Sharktooth Cutter -A-3 Tool Box -A-12 Pin Key | 43 | 19.5 |

Accessories

| Image | Catalog No. | Model No. | Description | Weight | |
|-------|-------------|-----------|--|------------------|------|
| | | | | lb. | kg |
| | 59470 | A-8 | Cable Carrier 60" (18 m) Capacity 1 $\frac{1}{4}$ " (32 mm) | 5 $\frac{1}{2}$ | 2.5 |
| | 59475 | A-9 | Cable Carrier 150-Foot (45,7) Capacity 1 $\frac{1}{4}$ " (32 mm) | 14 | 6.4 |
| | 59395 | A-34-12 | 12-Foot (3,7 m) Rear Guide Hose | 20 | 9.1 |
| | 59415 | A-34-10 | 10-Foot (3,1 m) Rear Guide Hose | 13 $\frac{3}{8}$ | 6.2 |
| | 59400 | A-34-16 | 16-Foot (4,9 m) Rear Guide Hose | 26 $\frac{1}{2}$ | 12.0 |
| | 59300 | A-20 | 8-Foot (2,4 m) Front Guide Hose Assembly | 25 | 11.4 |
| | 59205 | A-1 | Left-Hand RIDGID Drain Cleaning Mitt | 1/2 | 0.2 |
| | 59295 | A-2 | Right-Hand RIDGID Drain Cleaning Mitt | | |
| | 62467 | A-1HD | Heavy-Duty Left-Hand RIDGID Drain Cleaning Mitt | 1/2 | 0.2 |
| | 62472 | A-2HD | Heavy-Duty Right-Hand RIDGID Drain Cleaning Mitt | | |
| | 59360 | A-3 | Tool Box | 5 | 2.3 |
| | 59225 | A-12 | $\frac{1}{2}$ " Cable Pin Key | 1/2 | 0.2 |
| | 59440 | A-4 | Trap Spoon (30", 76 cm) | 1 $\frac{3}{4}$ | 0.8 |
| | 59240 | A-17 | Manhole Guide Pipe | 23 | 10.4 |
| | 59320 | A-369X | 1 $\frac{1}{4}$ " Jaw Assembly | 3/4 | 0.3 |
| | 59325 | A-368X | $\frac{7}{8}$ " Jaw Assembly | | |

Tools

| Image | Catalog No. | Model No. | Description | Replac. Blade(s) | |
|-------|-------------|-----------|---|------------------|-------|
| | | | | lb. | kg |
| | 59480 | T-11 | "H" Cutter, 2 $\frac{1}{2}$ " (65 mm) | | 97800 |
| | 59485 | T-12 | "H" Cutter, 3 $\frac{1}{2}$ " (89 mm) | | 97945 |
| | 59625 | T-21 | Spiral Sawtooth Cutter, 2 $\frac{1}{2}$ " (65 mm) | | 97970 |
| | 59765 | T-24 | 4-Blade Cutter, 2 $\frac{1}{2}$ " (65 mm) | | 97940 |
| | 59770 | T-25 | 4-Blade Cutter, 3 $\frac{1}{2}$ " (89 mm) | | 97975 |
| | 59775 | T-26 | 4-Blade Cutter, 4 $\frac{1}{2}$ " (114 mm) | | 97805 |
| | 59780 | T-26A | 4-Blade Cutter, 5 $\frac{1}{2}$ " (140 mm) | | 97980 |
| | 61770 | T-15A | Expanding Cutter, 4" - 6" (110-150 mm) | | 62970 |
| | 61790 | T-4 | Heavy-Duty Funnel Auger | | - |
| | 61800 | T-2 | Heavy-Duty Straight Auger | | - |
| | 61825 | T-15B | Expanding Cutter, 6" - 8" (150-200 mm) | | 62980 |
| | 61850 | T-17 | Spiral Bar Cutter, 6" (150 mm) | | 97955 |
| | 61855 | T-18 | Spiral Bar Cutter, 8" (200 mm) | | 97960 |
| | 61960 | T-16 | Spiral Bar Cutter, 4" (110 mm) | | 97855 |
| | 61970 | T-13 | Sawtooth Cutter, 2 $\frac{1}{2}$ " (65 mm) | | 98070 |
| | 62840 | T-1 | Straight Auger | | - |
| | 62845 | T-10 | Grease Cutter, 4 $\frac{1}{2}$ " (114 mm) | | 97865 |
| | 63075 | T-22 | Spiral Sawtooth Cutter, 3" (75 mm) | | 97970 |
| | 63085 | T-23 | Spiral Sawtooth Cutter, 4" (110 mm) | | 97850 |
| | 63105 | T-3 | Funnel Auger | | - |
| | 63110 | T-31 | Chain Knocker, For 3"- 4" Pipe (75-110 mm) | | 97985 |
| | 63115 | T-32 | Chain Knocker, For 6" Pipe (150 mm) | | 97990 |
| | 63120 | T-33 | Chain Knocker, For 8" Pipe (200 mm) | | 97995 |
| | 63145 | T-38 | Flue Brush, 1 $\frac{1}{2}$ " (40 mm) | | - |
| | 63150 | T-39 | Flue Brush, 2" (50 mm) | | - |
| | 63155 | T-40 | Flue Brush, 2 $\frac{1}{2}$ " (65 mm) | | - |
| | 63160 | T-41 | Flue Brush, 3" (76 mm) | | - |
| | 63165 | T-42 | Flue Brush, 3 $\frac{1}{2}$ " (89 mm) | | - |
| | 63170 | T-43 | Flue Brush, 4" (110 mm) | | - |
| | 63175 | T-44 | Flue Brush, 4 $\frac{1}{2}$ " (114 mm) | | - |
| | 63180 | T-46 | Flue Brush, 5 $\frac{1}{2}$ " (140 mm) | | - |
| | 63185 | T-47 | Flue Brush, 6" | | - |
| | 63190 | T-5 | A-3565 Key | | - |
| | 63195 | T-6 | Funnel Retrieving Auger Run Machine In Reverse | | - |
| | 63200 | T-7 | Hook Auger | | - |
| | 63205 | T-8 | Grease Cutter, 2 $\frac{1}{2}$ " (65 mm) | | 97920 |
| | 63210 | T-9 | Grease Cutter, 3 $\frac{1}{2}$ " (89 mm) | | 97925 |
| | 63240 | T-45 | Flue Brush, 5" (127 mm) | | - |
| | 98030 | T-50 | Includes 3 Sizes: 3-4-5" (75-110-127 mm) | | - |
| | 98035 | T-50-1 | Sharktooth Cutter, 3" (75 mm) | | 98005 |
| | 98040 | T-50-2 | Sharktooth Cutter, 4" (110 mm) | | 98010 |
| | 98045 | T-50-3 | Sharktooth Cutter, 5" (127 mm) | | 98015 |

C-14 Heavy-Duty Accessories

| Image | Catalog No. | Model No. | Description | Weight | |
|-------|-------------|-----------|--|--------|------|
| | | | | lb. | kg |
| | 48457 | - | C-14 Three-Carrier Cable Combination Kit Includes: 150' C-14 Cable, Ten Sections 1 $\frac{1}{4}$ ", Three Cable Carriers, A-3 Toolbox and A-12 Pin Key, T-2 HD Straight Auger; T-4 HD Funnel Auger; T-6 Funnel Retrieving Auger; T-8 Spade Cutter; T-13 Saw Tooth Cutters; T-50 Sharktooth | 160 | 72.6 |

Sectional Machines



K-1500G SECTIONAL MACHINE

- 2" to 10" (50 to 250 mm) Drain/Sewer Lines
- A gasoline engine makes the Model K-1500G well-suited for cleaning lines in remote locations where electrical power is unavailable. Cuts through roots fast.
- Unique, easy-to-use, instant-acting cable clutch maximizes operator control. Pull down on the handle and the cable spins at 600 RPM. Release handle, cable stops instantly.
- Comes equipped to use 1 1/4" (32 mm) cable to clean 3" (75 mm) to 10" (250 mm) lines through 300' (92 m).
- 6 HP gasoline engine drives cable via four-speed transmission. Allows the operator to vary the cable spinning speed to fit the application. Forward speeds of 333, 425 and 500 RPM, and a reverse speed of 250 RPM.
- Low-profile, four-wheel cart easily rolls to the job. Guards against machine upset and possible fuel spillage.
- Includes A-1 RIDGID® drain cleaning mitt and operator's manual.

MACHINE DIMENSIONS

- Width Wheel to Wheel – 26" (66 cm)
- Length Including Kickstand – 28" (71 cm)
- Ground to Top of Handle – 38" (97 cm)
- Back of Handle to Front – 49" (124 cm)
- Ground to Top of Housing Shell – 27" (60 cm)

| Catalog No. | Model No. | Description | Weight | |
|-------------|-------------------|--|--------|-------|
| | | | lb. | kg |
| 44587 | K-1500G | Machine Only with A-1 RIDGID Drain Cleaning Mitt, A-12 Coupling Pin Key and A-34-10 Rear Guide Hose, A-369-X 1¼" (32 mm) Jaw Set | 190 | 86.4 |
| 48462 | K-1500G with C-14 | Machine with Standard Equipment, includes: – Ten Sections Of C-14 Cable, Total 150' (45.7 m) – Three A-8 Cable Carriers – A-1 Left-Hand RIDGID Drain Cleaning Mitt – A-12 Coupling Pin Key – A-34-12 Rear Guide Hose – A-2864 Hex Key – A-3516 Hex Key – A-3 Tool Box – T-2 Heavy-Duty Straight Auger – T-4 Heavy-Duty Funnel Auger – T-6 Retrieving Auger – T-8 Grease Cutter – T-13 Sawtooth Cutter – T-50 Sharktooth Cutter | 350 | 159.0 |

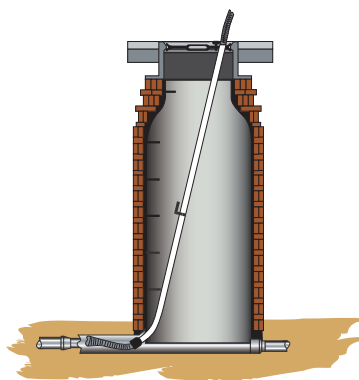







A-17 Manhole Guide Pipe

Adjusts 7' to 12', supports cables, locks into place quickly.















Model K-1500G with C-14 shown above.

Cables and Leaders

| | Catalog No. | Model No. | Description | Weight | |
|---|-------------|-----------|--|--------|-----|
| | | | | lb. | kg |
|  | 25036 | C-10 PC | 7/8" (22 mm) x 15' Cable with Inner Core (4,6 m) Requires A-368-X Jawset | 10 | 4.5 |
|  | 62275 | C-10 | 7/8" (22 mm) x 15' (4,6 m) All-Purpose Wind Requires A-368-X Jawset | 9 1/2 | 4.3 |
|  | 62280 | C-11 | 1 1/4" (32 mm) x 15' (4,6 m) Standard All-Purpose Wind. 3/8" (10 mm) Pitch. Good for 4" (110 mm) Traps, 3" (75 mm) - 8" (200 mm) Lines | 16 | 7.3 |
|  | 62285 | C-12 | 15' (4,6 m) Extra-Heavy-Duty Wind. 3/8" (10 mm) Pitch. Recommended For 4" (110 mm) - 10" (250 mm) Long Runs, No 4" (110 mm) Traps | 19 | 8.6 |
|  | 62295 | C-14 | 15' (4,6) Heavy-Duty Wind. 1/2" (13 mm) Pitch. Recommended For 3" (75 mm) - 10" (250 mm) Lines Through Cleanout, No 4" (110 mm) Traps | 16 | 6.8 |
|  | 62300 | C-15 | 15' (4,6) Extra-Flexible Wind. 1/2" (13 mm) Pitch. Recommended For 3" (75 mm) - 6" (150 mm) Lines Good for Traps | 12 | 5.5 |
|  | 63090 | T-27 | 1 1/4" (32 mm) x 25" (63,5 cm) Leader | 2 3/4 | 1.2 |

Accessories

| | Catalog No. | Model No. | Description | Weight | |
|---|-------------|-----------|---|--------|------|
| | | | | lb. | kg |
|  | 59205 | A-1 | Left-Hand RIDGID Drain Cleaning Mitt | 1/2 | 0.2 |
|  | 59225 | A-12 | 1/2" Cable Pin Key | | |
|  | 59240 | A-17 | Manhole Guide Pipe | 23 | 10.4 |
|  | 59295 | A-2 | Right-Hand RIDGID Drain Cleaning Mitt | 1/2 | 0.2 |
|  | 59300 | A-20 | 8-Foot (2,4 m) Front Guide Hose Assembly | 25 | 11.4 |
|  | 59320 | A-369X | 1 1/4" Jaw Assembly | 3/4 | 0.3 |
|  | 59360 | A-3 | Tool Box | 5 | 2.3 |
|  | 59395 | A-34-12 | 12-Foot (3,7 m) Rear Guide Hose | 20 | 9.1 |
|  | 59415 | A-34-10 | 10-Foot (3,1 m) Rear Guide Hose | 13 3/8 | 6.2 |
|  | 59440 | A-4 | Trap Spoon (30", 76 cm) | 1 3/4 | 0.8 |
|  | 59470 | A-8 | Cable Carrier 60" (18 m) Capacity 1 1/4" (32 mm) | 5 1/2 | 2.5 |
|  | 59475 | A-9 | Cable Carrier 150-Foot (45,7) Capacity 1 1/4" (32 mm) | 14 | 6.4 |
|  | 59400 | A-34-16 | 16-Foot (4,9 m) Rear Guide Hose | 26 1/2 | 12.0 |

Tools

| | Catalog No. | Model No. | Description | Replac. Blade(s) |
|---|-------------|-----------|--|------------------|
| | | | | |
|  | 59485 | T-12 | "H" Cutter, 3 1/2" (89 mm) | 97945 |
|  | 59625 | T-21 | Spiral Sawtooth Cutter, 2 1/2" (65 mm) | 97970 |
|  | 59765 | T-24 | 4-Blade Cutter, 2 1/2" (65 mm) | 97940 |
|  | 59770 | T-25 | 4-Blade Cutter, 3 1/2" (89 mm) | 97975 |
|  | 59775 | T-26 | 4-Blade Cutter, 4 1/2" (114 mm) | 97805 |
|  | 59780 | T-26A | 4-Blade Cutter, 5 1/2" (140 mm) | 97980 |
|  | 61770 | T-15A | Expanding Cutter, 4" - 6" (110-150 mm) | 62970 |
|  | 61790 | T-4 | Heavy-Duty Funnel Auger | - |
|  | 61800 | T-2 | Heavy-Duty Straight Auger | - |
|  | 61825 | T-15B | Expanding Cutter, 6" - 8" (150-200 mm) | 62980 |
|  | 61850 | T-17 | Spiral Bar Cutter, 6" (150 mm) | 97955 |
|  | 61855 | T-18 | Spiral Bar Cutter, 8" (200 mm) | 97960 |
|  | 61960 | T-16 | Spiral Bar Cutter, 4" (110 mm) | 97855 |
|  | 61970 | T-13 | Sawtooth Cutter, 2 1/2" (65 mm) | 98070 |
|  | 61975 | T-14 | Sawtooth Cutter, 3 1/2" (89 mm) | 98075 |
|  | 62840 | T-1 | Straight Auger | - |
|  | 62845 | T-10 | Grease Cutter, 4 1/2" (114 mm) | 97865 |
|  | 63075 | T-22 | Spiral Sawtooth Cutter, 3" (75 mm) | 97970 |
|  | 63085 | T-23 | Spiral Sawtooth Cutter, 4" (110 mm) | 97850 |
|  | 63105 | T-3 | Funnel Auger | - |
|  | 63110 | T-31 | Chain Knocker, For 3" - 4" Pipe (75-110 mm) | 97985 |
|  | 63115 | T-32 | Chain Knocker, For 6" Pipe (150 mm) | 97990 |
|  | 63120 | T-33 | Chain Knocker, For 8" Pipe (200 mm) | 97995 |
|  | 63145 | T-38 | Flue Brush, 1 1/2" (40 mm) | - |
|  | 63150 | T-39 | Flue Brush, 2" (50 mm) | - |
|  | 63155 | T-40 | Flue Brush, 2 1/2" (65 mm) | - |
|  | 63160 | T-41 | Flue Brush, 3" (76 mm) | - |
|  | 63165 | T-42 | Flue Brush, 3 1/2" (89 mm) | - |
|  | 63170 | T-43 | Flue Brush, 4" (110 mm) | - |
|  | 63175 | T-44 | Flue Brush, 4 1/2" (114 mm) | - |
|  | 63180 | T-46 | Flue Brush, 5 1/2" (140 mm) | - |
|  | 63190 | T-5 | A-3565 Key | - |
|  | 63195 | T-6 | Funnel Retrieving Auger Run Machine In Reverse | - |
|  | 63200 | T-7 | Hook Auger | - |
|  | 63205 | T-8 | Grease Cutter, 2 1/2" (65 mm) | 97920 |
|  | 63210 | T-9 | Grease Cutter, 3 1/2" (89 mm) | 97925 |
|  | 63240 | T-45 | Flue Brush, 5" (127 mm) | - |
|  | 98030 | T-50 | Includes 3 Sizes: 3-4-5" (75-110-127 mm) | - |
|  | 98035 | T-50-1 | Sharktooth Cutter, 3" (75 mm) | 98005 |
|  | 98040 | T-50-2 | Sharktooth Cutter, 4" (110 mm) | 98010 |
|  | 98045 | T-50-3 | Sharktooth Cutter, 5" (127 mm) | 98015 |

Rodder Machines





K-1000 RODDER MACHINE











- 8" to 24" (200 to 610mm) Drain/Sewer Lines.
- A rugged, compact machine suited for straight main line work in municipalities, universities, institutions and industry. Drives sectional sewer rods through long, straight runs of larger diameter pipe – up to 500 feet (150 m).
- Equipped with a 6 HP gasoline engine and forward/reverse transmission. Rod rotates at 133 RPM in forward and reverse at full throttle.
- Spring-loaded throttle control is hand operated. Varies rod speed within range. Returns engine speed to idle and disengages clutch when operator releases throttle.
- Adjustable torque limiter minimizes kinking of rods and excessive torque through transmission system.
- Large 10" (250 mm) wheels on frame for optimal transport.
- Includes A-1 RIDGID® drain cleaning mitt and operator's manual.

| Catalog No. | Model No. | Description | Weight | |
|-------------|-----------|---|--------|------|
| | | | lb. | kg |
| 59175 | K-1000 | Rodder Machine, includes: – B-3542 Rod Driver – A-2704 Tool Driver – A-3567 Drive Pin – R-0 Rod Turner – A-4558 Torque Adapter – A-12 Coupling Pin Key – A-1 Left-Hand RIDGID Drain Cleaning Mitt – A-2 Right-Hand RIDGID Drain Cleaning Mitt | 160 | 75.0 |
| 84295 | | Rodder Machine, same as above, plus: – 20 Sections of A-2475, 5/16" (8 mm) Rod, Total of 100' (30 m) – T-300 Spear Head Cutter – T-317 Auger – T-326 Pick-Up Tool | 210 | 95.0 |

Rods

| | Catalog No. | Model No. | Description | Weight | |
|---|-------------|-----------|--|--------|-----|
| | | | | lb. | kg |
|  | 60355 | A-2474 | 3' (0,9 m) Solid Sectional Rod, Includes: R-1 Male and R-2 Female Couplings | 1 ¼ | 0.6 |
|  | 60360 | A-2475 | 5' (1,5 m) Solid Sectional Rod, Includes: R-1 Male and R-2 Female Couplings | 1 ¾ | 0.8 |
|  | 60365 | A-2476 | 10' (3,0 m) Solid Sectional Rod, Includes: R-1 Male and R-2 Female Couplings | 3 | 1.4 |

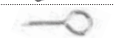
Accessories

| | Catalog No. | Model No. | Description | Weight | |
|---|-------------|-----------|--|--------|-----|
| | | | | lb. | kg |
|  | 59835 | K-10 | Complete Set of Quick- Connect Rod Couplings: One Each R-1 and R-2 | 3/8 | 0.2 |
|  | 59560 | R-1 | Male Rod Coupling | ¼ | 0.1 |
|  | 59555 | R-2 | Female Rod Coupling | 1/8 | |
|  | 61875 | R-7 | Male Tool Coupling, connects Tool Adapter to Rodding Tool | ½ | 0.2 |
|  | 61885 | R-8 | Female Tool Coupling, connects Tool to Tool Adapter | | |
|  | 60700 | A-2704 | Tool Adapter, includes R-2 and R-7 Couplings | 2 ¼ | 1.0 |
|  | 62170 | B-3542 | B-3542 Rod Holder | 3 3/8 | 1.5 |
|  | 62815 | R-0 | Rod Turner, used to manually turn Rods in short runs | 3 ¼ | |
|  | 59205 | A-1 | Left-Hand RIDGID Drain Cleaning Mitt | ½ | 0.2 |
|  | 59295 | A-2 | Right-Hand RIDGID Drain Cleaning Mitt | | |
|  | 59360 | A-3 | Tool Box | 5 | 2.3 |
|  | 59225 | A-12 | ½" Cable Pin Key | ½ | 0.2 |

RODS, RODDING TOOLS AND ACCESSORIES

- RIDGID K-10 quick-connect couplings make rodding jobs easier than ordinary threaded couplings:
 - To connect rods, align and snap them together for a solid connection (Fig. 1 and 2).





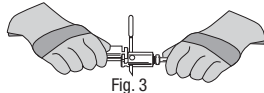













- To disconnect, insert the pin key and slide the couplings apart (Fig. 3).



- One coupling pin key replaces assembly tool and wrench required to connect ordinary threaded couplings. Easy-to-add rods or tools. No bulky reels.
- Convert existing tools and rods to the RIDGID quick-connect system
 - One pair of R1 and R2 couplings substitute for one threaded coupling.
 - Standard left-hand and-right hand rod nuts fasten R1 and R2 couplings to existing rods.
 - R-8 couplings adapt each rod tool to quick-connect system.
 - A-2704 adapts rod couplings to larger-size tool couplings.

Tools

| | Catalog No. | Model No. | Description | Weight | |
|---|-------------|-----------|-------------------------------------|--------|-----|
| | | | | lb. | kg |
|  | 62045 | T-300 | Spear Head | 1 7/8 | 0.8 |
|  | 62050 | T-301 | Round Stock Corkscrew, 1½" (40 mm) | 1 ¼ | 0.6 |
|  | 62055 | T-302 | Round Stock Corkscrew, 2" (50 mm) | 1 ½ | 0.7 |
|  | 62060 | T-303 | Round Stock Corkscrew, 2½" (65 mm) | 1 ¾ | 0.8 |
|  | 62065 | T-304 | Round Stock Corkscrew, 3" (75 mm) | | |
|  | 62075 | T-306 | Double Corkscrew, 3" (75 mm) | 2 ¼ | 1.0 |
|  | 62080 | T-307 | Double Corkscrew, 4" (110 mm) | 2 ½ | 1.1 |
|  | 62095 | T-310 | Square Stock Corkscrew, 4" (110 mm) | | |
|  | 62105 | T-312 | Square Stock Corkscrew, 6" (150 mm) | 3 ¾ | 1.7 |
|  | 62370 | T-313 | Square Stock Corkscrew, 8" (200 mm) | 6 ½ | 3.0 |
|  | 62110 | T-316 | Auger, 3" (75 mm) | 3 | 1.4 |
|  | 62115 | T-317 | Auger, 4" (110 mm) | 3 ½ | 1.5 |
|  | 62125 | T-319 | Auger, 6" (150 mm) | 5 | 2.3 |
|  | 62385 | T-320 | Auger, 8" (200 mm) | 8 ½ | 3.9 |
|  | 62390 | T-321 | Auger, 10" (250 mm) | 9 ½ | 4.3 |
|  | 62140 | T-326 | Pick-Up Tool | 1 | 0.5 |

The following Heavy-Duty Cable tools are also recommended for use with the rod:

| | Catalog No. | Model No. | Description | Weight | |
|---|-------------|-----------|-------------------------------------|--------|----|
| | | | | lb. | kg |
|  | 61800 | T-2 | Heavy-Duty Straight Auger | | |
|  | 61790 | T-4 | Heavy-Duty Funnel Auger | | |
|  | 63200 | T-7 | Hook Auger | | |
|  | 61960 | T-16 | Spiral Bar Cutter, 4" (110 mm) | | |
|  | 61850 | T-17 | Spiral Bar Cutter, 6" (150 mm) | | |
|  | 61855 | T-18 | Spiral Bar Cutter, 8" (200 mm) | | |
|  | 63085 | T-23 | Spiral Sawtooth Cutter, 4" (110 mm) | | |
|  | 59765 | T-24 | 4-Blade Cutter, 2½" (65 mm) | | |
|  | 59770 | T-25 | 4-Blade Cutter, 3 ½" (89 mm) | | |
|  | 59775 | T-26 | 4-Blade Cutter, 4 ½" (114 mm) | | |
|  | 59780 | T-26A | 4-Blade Cutter, 5 ½" (140 mm) | | |

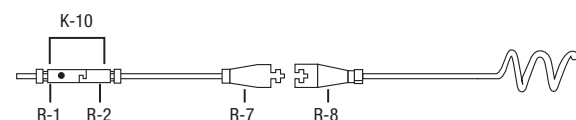

Water Jetting Machines



Model KJ-1350-C on Model H-10 Cart

KJ-1350 WATER JETTER

- 1 1/4" to 4" (32 mm to 100 mm) Drain Lines.
- This jetter propels a highly flexible hose through 1 1/4" to 4" (32 mm to 100 mm) lines—blasting through sludge, soap and grease blockages. As you pull the hose back, it power scrubs the line, flushing debris away and restoring drain lines to their free-flowing capacity.
- Powerful: Actual working pressure of 1350 psi (93 bar) and flow of 1.4 GPM (5.3 l/min) for fast, effective cleaning of lines.
- Pulse Action: Activate the Model KJ-1350's plus action to easily negotiate difficult bends and traps. The Model KJ-1350-2 has a second level of pulse.
- Portable and Compact: The optional H-10 Cart rolls the jetter and hose to the job site. Jetter and hose reel are easily removed from the cart in seconds for hard to reach drains or remote storage. The compact cart offers a retractable handle and swivel hose reel minimizing storage space. Optional adapter allows the KJ-1350 to be mounted on the upright H-30 Cart.
- Electrical Requirement: The 1.5 HP motor draws a maximum of 14 Amps and can run on most standard 115V circuits.
- Easy to use: Thrust propels the hose down the line. You simply guide the hose into the drain.
- High Quality: Duplex pump with corrosion-resistant, forged brass head. New pressure control valve allows quick and easy pressure adjustment.
- Dependable: Reduced number of fittings, hoses and parts minimizes leaks and down time keeping you on the job.
- Versatile: Optional power washer package cleans cables, tools and other heavily soiled equipment.
- CSA approved. Approved to UL standards (NRTLCL).

Jetter Nozzles

| Catalog No. | Model No. | Description | Female NPT Thread in. |
|-------------|-----------|----------------------------|-----------------------|
| 64707 | H-21 | KJ-1350 Propulsion Nozzle | |
| 64712 | H-22 | KJ-1350 Penetrating Nozzle | 1/8 |
| 64717 | H-24 | KJ-1350 Drop Head Nozzle | |
| 64722 | H-31 | KJ-1350 Propulsion Nozzle | 1/4 |
| 82832 | H-25 | KJ-1350 Spinning Nozzle | 1/8 |
| 64727 | H-32 | KJ-1350 Penetrating Nozzle | 1/4 |

Trap Leaders

| Catalog No. | Model No. | Description | Female NPT Thread in. | Male NPT Thread in. |
|-------------|-----------|--|-----------------------|---------------------|
| 50002 | HL-1 | Flexible Leader, 3/16" - Fits 1/8" & 3/16" Hoses | 1/8 | 1/8 |
| 50007 | HL-2 | Flexible Leader, 1/4" - Fits 1/4" & 3/8" Hoses | | 1/8 |

Accessories

| Catalog No. | Model No. | Description |
|-------------|-----------|---|
| 41937 | - | RIDGID® Leather Drain Cleaning Gloves |
| 47542 | H-21 | Nozzle Cleaning Tool |
| 48367 | H-25 | Winterizing Kit |
| 51572 | H-1235 | Wash Wand Hose 1/2" x 35' |
| 62592 | H-10 WH | H-10 Cart with Hose Reel and 100' x 3/16" Trap Hose |
| 62757 | - | Nylon Storage Bag |
| 62882 | H-5 | Mini Hose Reel |
| 62892 | H-30A | KJ-1350 Adapter to Fit H-30 Cart |
| 64697 | H-10 | H-10 Cart with Hose Reel |
| 64702 | HW-EL | Pressure Wash (Gun only) |
| 64737 | H-30 | H-30 Cart with Hose Reel |
| 67187 | H-32 | Jet Vac |
| 70032 | - | RIDGID® PVC Drain Cleaning Gloves |

Machine Options

| Catalog No. | Model No. | Description | Weight | |
|-------------|------------|--|--------|------|
| | | | lb. | kg |
| 62587 | KJ-1350 | KJ-1350 Standard Jetter with Pulse: H-21, H-22, and H-24 1/8" NPT Nozzles, 25' x 1/8" (7.6 m x 3.2 mm) Sink Trap Hose, Nylon Storage Bag, Nozzle Cleaning Tool | 70 | 31.7 |
| 62597 | KJ-1350-C | Above With: H-10 Cart, 100' (30.5 m) x 1/4" (6.4 mm) Trap Hose | 120 | 54.4 |
| 63107 | KJ-1350-2 | KJ-1350 Jetter with Dual Pulse: H-21, H-22, and H-24 1/8" NPT Nozzles, 50' x 1/8" (15.2 m x 3.2 mm) Sink Trap Hose, Nylon Storage Bag, Nozzle Cleaning Tool | 72 | 32.7 |
| 63112 | KJ-1350-2C | Above With: H-10 Cart, 100' (30.5 m) x 1/4" (6.4 mm) Trap Hose | 122 | 55.3 |

Jetter Hoses

| Catalog No. | Model No. | Description | Male NPT Thread | Hose I.D. | Hose O.D. |
|-------------|-----------|---------------------------|-----------------|-----------|-----------|
| | | | in. | in. | in. |
| 47597 | H-1435 | 3/16" x 35' (11 m) | 1/8 | 3/16 | 1/4 |
| 47602 | H-1450 | 3/16" x 50' (15 m) | 1/8 | 3/16 | 1/4 |
| 47607 | H-1250 | 1/4" x 50' (15 m) | 1/4 | 1/4 | 1/2 |
| 49272 | H-1475 | 3/16" x 75' (23 m) | 1/8 | 3/16 | 1/4 |
| 49277 | H-1400 | 3/16" x 100' (30 m) | 1/8 | 3/16 | 1/4 |
| 49487 | H-1215 | 1/4" x 150' (46 m) | 1/4 | 1/4 | 1/2 |
| 51587 | H-1211 | 1/4" x 100' (33 m) | 1/4 | 1/4 | 1/2 |
| 51597 | H-1220 | 1/4" x 200' (61 m) | 1/4 | 1/4 | 1/2 |
| 52957 | H-1825 | 1/8" x 25' Sink Trap Hose | 1/8 | 1/8 | 3/16 |
| 53037 | H-1850 | 1/8" x 50' Sink Trap | 1/8 | 1/8 | 3/16 |
| 64732 | H-1415 | 3/16" x 150' (45.5 m) | 1/8 | 3/16 | 1/4 |

Water Jetting Machines



Model KJ-1750-C on Model H-30 Cart

KJ-1750 WATER JETTER

- 1 1/4" to 4" (32 to 100mm) Drain Lines.
- This jetter propels a highly flexible hose through 1 1/4" to 4" (32 to 100mm) lines—blasting through sludge, soap and grease blockages. As you pull the hose back, it power scrubs the line, flushing debris away and restoring drain lines to their free-flowing capacity.
- Powerful: Actual working pressure of 1750 psi and flow of 1.4 GPM (5.3 l/min) for fast, effective cleaning of lines.
- Pulse Action: Two levels of pulse are standard. Activate the KJ-1750's pulse action to easily negotiate difficult bends and traps.
- Portable: The optional H-30 Cart rolls the jetter and hose to the job site. The jetter is easily removed from the cart in seconds for hard to reach drain or for remote storage. Optional adapter allows the KJ-1750 to be mounted on the compact H-10 Cart.
- Electrical Requirement: The 2.0 HP motor draws a maximum of 17 Amps which requires a 20 Amp, 115V circuit.
- Easy to use: Thrust propels the hose down the line. You simply guide the hose into the drain.
- High Quality: Duplex pump with corrosion-resistant, forged brass head. New pressure control valve allows quick and easy pressure adjustment.
- Dependable: Reduced number of fittings, hoses and parts minimizes leaks and down time keeping you on the job.
- Versatile: Optional power washer package cleans cables, tools and other heavily soiled equipment.
- CSA approved. Approved to UL standards (NRTLCL).

Jetter Nozzles

| Catalog No. | Model No. | Description | Female NPT Thread in. |
|-------------|-----------|----------------------------|-----------------------|
| 64742 | H-41 | KJ-1750 Propulsion Nozzle | 1/8 |
| 64747 | H-42 | KJ-1750 Penetrating Nozzle | |
| 64752 | H-44 | KJ-1750 Drop Head Nozzle | |
| 64757 | H-51 | KJ-1750 Propulsion Nozzle | 1/4 |
| 64762 | H-52 | KJ-1750 Penetrating Nozzle | |
| 82837 | H-45 | KJ-1750 Spinning Nozzle | 1/8 |

Accessories

| Catalog No. | Model No. | Description |
|-------------|-----------|---|
| 47542 | H-21 | Nozzle Cleaning Tool |
| 48367 | H-25 | Winterizing Kit |
| 51572 | H-1235 | Wash Wand Hose 1/2" x 35" |
| 62592 | H-10 WH | H-10 Cart with Hose Reel and 100' x 3/16" Trap Hose |
| 62877 | H-30 WH | H-30 Cart with Hose Reel and 110' x 1/4" (33 m x 4.8 mm) Jet Hose |
| 62882 | H-5 | Mini Hose Reel |
| 62897 | H-1235 | KJ-1750 Adapter to Fit H-10 Cart |
| 64697 | H-10 | H-10 Cart with Hose Reel |
| 64702 | HW-EL | Pressure Wash (Gun only) |
| 64737 | H-30 | H-30 Cart with Hose Reel |
| 67187 | H-32 | Jet Vac |
| 70032 | - | RIDGID® PVC Drain Cleaning Gloves |
| 41937 | - | RIDGID® Leather Drain Cleaning Gloves |
| 62757 | - | Nylon Storage Bag |

Machine Options

| Catalog No. | Model No. | Description | Weight | |
|-------------|-----------|---|--------|------|
| | | | lb. | kg |
| 62687 | KJ-1750 | KJ-1750 Jetter with Dual Pulse: H-41, H-42, and H-44 1/8" NPT Nozzles, H-51 and H-52 1/4" NPT Nozzles, 50' x 1/8" (15.2 m x 3.2 mm) Sink Trap Hose, Nylon Storage Bag, Nozzle Cleaning Tool | 75 | 34.0 |
| 62697 | KJ-1750-C | Above With: H-30 Cart, 110' x 1/2" (33.5 m x 6.4 mm) Jet Hose | 155 | 70.3 |
| 67332 | | 62687 with: H-10 Cart, 100' x 1/4" (30.5 m x 6.4 mm) Trap Hose | 125 | 56.7 |

Jetter Hoses

| Catalog No. | Model No. | Description | Male NPT Thread | Hose I.D. | Hose O.D. |
|-------------|-----------|---------------------------|-----------------|-----------|-----------|
| | | | in. | in. | in. |
| 47597 | H-1435 | 3/16" x 35' (11 m) | 1/8 | 3/16 | 1/4 |
| 47602 | H-1450 | 3/16" x 50' (15 m) | 1/8 | 3/16 | 1/4 |
| 47607 | H-1250 | 1/4" x 50' (15 m) | 1/4 | 1/4 | 1/2 |
| 49272 | H-1475 | 3/16" x 75' (23 m) | 1/8 | 3/16 | 1/4 |
| 49277 | H-1400 | 3/16" x 100' (30 m) | 1/8 | 3/16 | 1/4 |
| 49487 | H-1215 | 1/4" x 150' (46 m) | 1/4 | 1/4 | 1/2 |
| 51587 | H-1211 | 1/4" x 100' (33 m) | 1/4 | 1/4 | 1/2 |
| 51597 | H-1220 | 1/4" x 200' (61 m) | 1/4 | 1/4 | 1/2 |
| 52957 | H-1825 | 1/8" x 25' Sink Trap Hose | 1/8 | 1/8 | 3/16 |
| 53037 | H-1850 | 1/8" x 50' Sink Trap | 1/8 | 1/8 | 3/16 |
| 64732 | H-1415 | 3/16" x 150' (45.5 m) | 1/8 | 3/16 | 1/4 |

Trap Leaders

| Catalog No. | Model No. | Description | Female NPT Thread | Male NPT Thread |
|-------------|-----------|--|-------------------|-----------------|
| | | | in. | in. |
| 50002 | HL-1 | Flexible Leader, 3/16" - Fits 1/8" & 3/16" Hoses | 0 | 0 |
| 50007 | HL-2 | Flexible Leader, 1/4" - Fits 1/4" & 3/8" Hoses | 0 | 0 |

Water Jetting Machines



KJ-2200 WATER JETTER

- 1 1/4" to 6" (32 to 150 mm) Drain Lines.
- This jetter propels a highly flexible hose through 1 1/4" to 6" (32 mm to 150 mm) lines blasting through sludge, soap and grease blockages. As you pull the hose back, it power scrubs the line flushing debris away, restoring drain lines to their full, free-flowing capacity.
- **Powerful** – Actual working pressure of 2200 psi (150 bar) and flow of 2.4 GPM (9 l/min) for fast, effective cleaning of lines.
- **Easy to Use** – Thrust propels the hose down the line. You simply guide the hose into the drain.
- **Pulse Action** – Activate the KJ-2200's pulse action to easily negotiate difficult bends and traps.
- **Portable** – The optional H-30 cart rolls the jetter and hose to the job site. The jetter is easily removed from the cart in seconds for hard to reach drains, indoor applications or remote storage.
- **Convenient** – Standard equipment includes FV-1 foot valve. It makes remote or indoor operation simple and safe. You control the jetting action at the drain while leaving the jetter outdoors.
- **Quality & Dependability** – Triplex pump with corrosion-resistant, forged brass head. Reduced number of fittings, hoses and parts minimizes leaks and down time – keeping you on the job.
- **Versatile** – Optional power washer package cleans cables, tools and other heavily soiled equipment.
- New and improved 6.5 HP Recoil start gasoline engine starts easily. Features: ON/OFF switch; choke and throttle controls; easy access oil fill and dip stick.

Machine Options

| Catalog No. | Model No. | Description | Weight | |
|-------------|-----------|---|--------|------|
| | | | lb. | kg |
| 63877 | KJ-2200 | KJ-2200 Jetter with Pulse – H-61, H-62, and H-64 1/8" NPT Nozzles – H-71 and H-72 1/4" NPT Nozzles – 75' x 3/16" (22.8 m x 4.8 mm) Trap Hose – FV-1 Foot Valve – Nozzle Cleaning Tool – H-1235 Wash Wand Hose 1/2" x 35' (10.7 m x 12.7 mm) | 65 | 29.5 |
| 63882 | KJ-2200-C | Above With: – H-30 Cart – 110' x 1/4" (33 m x 4.8 mm) Jet Hose | 145 | 65.8 |



Jetter Hoses

| Catalog No. | Model No. | Description | Male NPT Thread | Hose I.D. | Hose O.D. |
|-------------|-----------|-----------------------|-----------------|-----------|-----------|
| | | | in. | in. | in. |
| 47597 | H-1435 | 3/16" x 35' (11 m) | 1/8 | 3/16 | 1/4 |
| 47602 | H-1450 | 3/16" x 50' (15 m) | 1/8 | 3/16 | 1/4 |
| 49272 | H-1475 | 3/16" x 75' (23 m) | 1/8 | 3/16 | 1/4 |
| 49277 | H-1400 | 3/16" x 100' (30 m) | 1/8 | 3/16 | 1/4 |
| 47607 | H-1250 | 1/4" x 50' (15 m) | 1/4 | 1/4 | 1/2 |
| 51587 | H-1211 | 1/4" x 100' (33 m) | 1/4 | 1/4 | 1/2 |
| 49487 | H-1215 | 1/4" x 150' (46 m) | 1/4 | 1/4 | 1/2 |
| 51597 | H-1220 | 1/4" x 200' (61 m) | 1/4 | 1/4 | 1/2 |
| 64732 | H-1415 | 3/16" x 150' (45,5 m) | 1/8 | 3/16 | 1/4 |

Jetter Nozzles

| Catalog No. | Model No. | Description | Female NPT Thread |
|-------------|-----------|--------------------|-------------------|
| | | | in. |
| 64772 | H-61 | Propulsion Nozzle | 1/8 |
| 64777 | H-62 | Penetrating Nozzle | |
| 64782 | H-64 | Drop Head Nozzle | |
| 82842 | H-65 | Spinning Nozzle | |
| 64787 | H-71 | Propulsion Nozzle | 1/4 |
| 64792 | H-72 | Penetrating Nozzle | |
| 82852 | H-75 | Spinning Nozzle | |

Trap Leaders

| Catalog No. | Model No. | Description | Female NPT Thread | Male NPT Thread |
|-------------|-----------|--|-------------------|-----------------|
| | | | in. | in. |
| 50002 | HL-1 | Flexible Leader, 3/16" - Fits 1/8" & 3/16" Hoses | 0 | 0 |
| 50007 | HL-2 | Flexible Leader, 1/4" - Fits 1/4" & 3/8" Hoses | 0 | 0 |

Accessories

| Catalog No. | Model No. | Description | Weight | Weight |
|-------------|-----------|---|--------|--------|
| | | | lb. | kg |
| 62882 | H-5 | Mini Hose Reel | - | - |
| 64737 | H-30 | H-30 Cart with Hose Reel | - | - |
| 62877 | H-30 WH | H-30 Cart with Hose Reel and 110' x 1/4" (33 m x 4.8 mm) Jet Hose | - | - |
| 64077 | HP-22 | Pressure Wash Package, KJ-2200 | - | - |
| 64767 | HW-22 | Wash Wand, KJ-2200 | - | - |
| 48157 | FV-1 | Foot Valve | - | - |
| 66732 | HF-4 | Quick Connect Hose (Reel to Foot Valve) | - | - |
| 48367 | H-25 | Winterizing Kit | - | - |
| 47542 | H-21 | Nozzle Cleaning Tool | - | - |
| 67187 | H-32 | Jet Vac | - | - |
| 70032 | - | RIDGID® PVC Drain Cleaning Gloves | 1/2 | 0.2 |
| 41937 | - | RIDGID® Leather Drain Cleaning Gloves | 1/2 | 0.2 |
| 51572 | H-1235 | Wash Wand Hose 1/2". x 35" | - | - |

Water Jetting Machines



KJ-3100 WATER JETTER

- 2" to 10" (50 to 250 mm) Drain Lines.
- The RIDGID® Model KJ-3100 portable water jetter gives you 3000 psi (205 bar) actual working pressure to handle large commercial and industrial applications. This jetter propels a highly flexible and lightweight hose through 2" to 10" (50 to 250 mm) lines blasting through sludge, soap, grease, and sediment blockages. As you pull the hose back, it power scrubs the line flushing debris away and restoring drain lines to their full, free-flowing capacity – all without the use of harmful chemicals.
- **Powerful** – Actual working pressure of 3000 psi (205bar) and flow of 5.5 GPM (21 l/min) for fast, effective cleaning of lines.
- **Lightweight Hose** – Hose with nylon braid provides significant weight reduction and increased flexibility – all without reducing strength. Allows the thrust to propel the hose further down the line.
- **Complete** – With the Model KJ-3100's removable hose reel, there is no need to purchase expensive portable hose reels. Standard packages come equipped to handle indoor and remote applications.
- **Convenient** – Completely remove the hose reel to ease loading onto service trucks. Simply rotate the hose reel forward to gain full access to the engine's gas tank and air filter.
- **Maneuverable** – In the heavy-duty 3000 psi (205bar) jetter category, the RIDGID KJ-3100 is one of the most maneuverable jetters on the market. The unit, on its unique two-wheeled cart, easily fits through standard size doors and can negotiate tight turns with the greatest of ease.
- **Pulse Action** – Activate the Model KJ-3100's pulse action to easily negotiate difficult bends and traps.
- **Quality & Dependability** – Triplex pump with corrosion-resistant, forged brass head. Gear reducer allows pump to run at slower (optimal) speed. Reduced number of fittings, hoses and parts minimizes leaks and downtime – keeping you on the job.
- **Versatile** – Power wash package and chemical injector system cleans cables, tools, and other heavily soiled equipment.
- **Quick Start** – 16 HP Recoil start gasoline engine starts easily. Features: ON/OFF switch; fuel shutoff; choke and throttle controls; easy access oil fill and dip stick.

| Catalog No. | Model No. | Description | Weight | | Weight w/o | Weight w/o |
|-------------|-----------|---|--------|-------|------------|------------|
| | | | lb. | kg | Hose Reel | Hose Reel |
| 37413 | KJ-3100 | KJ-3100 Jetter with Pulse – H-111 and H-112 1/4" NPT Nozzles – H-38 Hose Reel with 200' x 3/8" (61 m x 10 mm) ID Jet Hose – 50' x 3/8" (15 m x 10 mm) ID Jet/Wash Hose – FV-1 Foot Valve – Nozzle Cleaning Tool – HW-30 Wash Wand – Root Ranger Root Cutting Nozzle – HF-4 Quick Connect Hose | 272 | 125.0 | 214 | 97 |



Jetter Nozzles

| Catalog No. | Model No. | Description | Female NPT Thread |
|-------------|-----------|---------------------------------|-------------------|
| | | | in. |
| 38698 | H-101 | Propulsion Nozzle | 1/8 |
| 38713 | H-102 | Penetrating Nozzle | |
| 38703 | H-104 | Drop Head Nozzle | |
| 38723 | H-105 | Spinning Nozzle | |
| 38693 | H-111 | Propulsion Nozzle | |
| 38708 | H-112 | Penetrating Nozzle | 1/4 |
| 38718 | H-115 | Spinning Nozzle | |
| 16713 | RR3000 | Root Ranger Root Cutting Nozzle | |

Jetter Hoses

| Catalog No. | Model No. | Description | Male NPT Thread | Hose I.D. | Hose O.D. |
|-------------|-----------|------------------------------------|-----------------|-----------|-----------|
| | | | in. | in. | in. |
| 47597 | H-1435 | 3/16" x 35' (11 m) | 1/8 | 3/16 | 1/4 |
| 47602 | H-1450 | 3/16" x 50' (15 m) | 1/8 | 3/16 | 1/4 |
| 49272 | H-1475 | 3/16" x 75' (23 m) | 1/8 | 3/16 | 1/4 |
| 49277 | H-1400 | 3/16" x 100' (30 m) | 1/8 | 3/16 | 1/4 |
| 64732 | H-1415 | 3/16" x 150' (45.5 m) | 1/8 | 3/16 | 1/4 |
| 64832 | H-3850 | 3/8" ID x 50' (15 m) Jet/Wash Hose | 1/4 | 3/8 | 5/8 |
| 64837 | H-3810 | 3/8" ID x 100' (30 m) Jet Hose | 1/4 | 3/8 | 5/8 |
| 64842 | H-3815 | 3/8" ID x 150' (45.5 m) Jet Hose | 1/4 | 3/8 | 5/8 |
| 64847 | H-3820 | 3/8" ID x 200' (61 m) Jet Hose | 1/4 | 3/8 | 5/8 |
| 64857 | H-3830 | 3/8" ID x 300' (91 m) Jet Hose | 1/4 | 3/8 | 5/8 |

Trap Leaders

| Catalog No. | Model No. | Description | Female NPT Thread | Male NPT Thread |
|-------------|-----------|--|-------------------|-----------------|
| | | | in. | in. |
| 50002 | HL-1 | Flexible Leader, 3/16" - Fits 1/8" & 3/16" Hoses | 1/8 | 1/8 |
| 50007 | HL-2 | Flexible Leader, 1/4" - Fits 1/4" & 3/8" Hoses | | 1/8 |

Accessories

| Catalog No. | Model No. | Description |
|-------------|-----------|--|
| 62882 | H-5 | Mini Hose Reel |
| 64862 | H-38 | H-38 Hose Reel Assembly |
| 64902 | H-38 WH | Hose Reel with 200' (61 m) x 3/8" ID Hose (Fits KJ-3100) |
| 64797 | HW-30 | Wash Wand, KJ-3100 |
| 48367 | H-25 | Winterizing Kit |
| 48157 | FV-1 | Foot Valve |
| 66732 | HF-4 | Quick Connect Hose (Reel to Foot Valve) |
| 47542 | H-21 | Nozzle Cleaning Tool |
| 67187 | H-32 | Jet Vac |
| 70032 | - | RIDGID® PVC Drain Cleaning Gloves |
| 41937 | - | RIDGID® Leather Drain Cleaning Gloves |

Utility Pumps



1/6 HP DEWATERING PUMP

- Corrosion-resistant reinforced thermoplastic housing, volute, and impeller.
- Bottom suction design filters and removes water down to 3/8" of surface.
- 1 1/4" NPS discharge with 3/4" garden hose adapter included.
- Easy carry handle for portability.
- 3-year limited warranty.

| Catalog No. | Model No. | Description |
|-------------|-----------|---|
| 47283 | RU16H | 1/6 HP Dewatering Pump 1 1/4" X 16 Ft. Collapsible Hose 44 GPM @ 5' |



1/4 HP DEWATERING PUMP

- Corrosion-resistant, reinforced thermoplastic motor housing, volute and impeller.
- Bottom suction design filters and removes water fast down to 1/8" of surface.
- 3/4" plastic discharge adapter connects to standard garden hose.
- Top center 3/4" discharge design provides balanced installation.
- 20' power cord to reach the toughest places.
- 3-year limited warranty.

| Catalog No. | Model No. | Description |
|-------------|-----------|---------------------------------------|
| 85987 | TP-250 | 1/4 HP Dewatering Pump 15 GPM @ 5' |



1/4 HP AUTO ON/OFF DEWATERING PUMP

- Water detection technology, turns the pump on and off automatically with the presence of water.
- Energy efficient, high flow 1/4 HP oil-free motor.
- Corrosion-resistant, sealed thermoplastic construction for submersible use.
- 1 1/4" discharge with garden hose adapter included.
- Bottom suction design filters debris and removes water down to 3/8" of surface.
- Plug in, and leave the pump unattended for worry-free water removal.
- Motor rated 2.5 Amps.
- 3-year limited warranty.

| Catalog No. | Model No. | Description |
|-------------|-----------|---|
| 47278 | RUA25 | 1/4 HP Auto ON/OFF Dewatering Pump 44 GPM @ 5' |



1/4 HP AUTO ON/OFF DEWATERING PUMP W/FREEZE PROTECTION

- Water detection technology, turns the pump on and off automatically with the presence of water.
- Applications include dewatering pool covers and other situations requiring water removal.
- Built-in debris and freeze protection.
- Check valve reducer included to reduce short-cycling.
- Plug in, and leave the pump unattended for worry-free water removal.
- 25 ft. power cord.
- Energy efficient, high flow oil-free motor.
- Sealed thermoplastic construction for submersible use.
- Strainer filters debris to minimize clogging.
- ON level - 2 1/8", OFF level - 3/4".
- 3-year limited warranty.

| Catalog No. | Model No. | Description |
|-------------|-----------|---|
| 47273 | RAPC250 | 1/4 HP Auto ON/OFF Dewatering Pump w/Freeze Protection 43 GPM @ 5' |



UTILITY TRANSFER PUMP

- Transfer Pumps easily and efficiently move water from one location to another.
- Rugged, cast-iron pump housing and motor for durability with easy-priming outlet.
- Cast-iron transfer pump pit for tough pump applications.
- Easy-carry cast-iron handle for portability.
- Portable transfer pump you can take anywhere.
- High performance 1/2 HP motor.
- 3/4" brass hose adapters connect to standard garden hose.
- Applications include drainage, dewatering flooded basements, emptying stock tanks, draining water heaters, and charging polyglycol radiant heating lines.
- Boosts pressure up to 50 PSI.
- 3-year limited warranty.

| Catalog No. | Model No. | Description |
|-------------|-----------|--|
| 47268 | RU50K | 1/2 HP cast-iron transfer pump Reinforced thermoplastic storage case Suction strainer 3/4" brass hose adapters 950 GPH @ 25' |

Utility Pumps



SEMI-TRASH PUMPS

- Our gas powered semi-trash pumps are powered by Honda® engines that meet EPA Phase 3 Emission Standards.
- NPT suction/discharge for easy connection to standard discharge hose.
- Passes up to 5/8" solids.
- Rugged, aluminum and cast-iron gasoline-powered water transfer utility pump.
- OHV 4-cycle Honda engine.
- Heavy-duty water transfer pump you can take anywhere.
- Heavy-duty aluminum roll cage and pump housing protect and provide stability.
- 1 gallon gas reservoir.
- Cast-iron pump casing and impeller.
- Maximum suction lift 25'.
- 90-degree discharge fitting eliminates discharge hose kinking.
- 3-year limited warranty.

| Catalog No. | Model No. | Description |
|-------------|-----------|--|
| 85957 | TP-4000 | 4 HP - 2 in. npt Gasoline-powered Honda GX series OHV Engine 160 GPM @ 5 Ft. |
| 85962 | TP-5500 | 5.5 HP - 3 in. npt Gasoline-powered Honda GX series OHV Engine 265 GPM @ 5 Ft. |



UTILITY PUMP HOSE KITS

- Rugged durability for high-volume water removal.
- Kit includes: Reinforced intake hose, lay flat discharge hose, debris strainer.
- 3-year limited warranty.

| Catalog No. | Model No. | Description |
|-------------|-----------|--|
| 90702 | TP2HK | 2" X 20' Hose Kit for TP-4000 gas powered utility pump |
| 90707 | TP3HK | 3" X 20' Hose Kit for TP-5500 gas powered utility pump |

Pump Accessories



ADVANTEXT™ WATER SENSOR

- Detects water as low as 3/16" Perfect for floor drains, water heaters.
- 3-year limited warranty.

| Catalog No. | Model No. | Description |
|-------------|-----------|--|
| 47663 | RFS | AdvantEXT™ Monitoring System "Lay Flat" Water Sensor |

Pump Accessories



1 1/2" CHECK VALVE

- Kit Includes: – 1 1/2" Check Valve, (2) rubber boots, (4) hose clamps.
- 3-year limited warranty
- Sold as master pack of 10 pieces.

| Catalog No. | Model No. | Description |
|-------------|------------|---------------------------------|
| 47678 | 57028-RDG1 | 1 1/2" sump in-line check valve |



2" CHECK VALVE

- Kit Includes: – 2" check valve, (2) rubber boots, (4) hose clamps.
- 3-year limited warranty
- Sold as master pack of 6 pieces.

| Catalog No. | Model No. | Description |
|-------------|------------|----------------|
| 47673 | 66038-RDG1 | 2" check valve |



1 1/2" THREADED CHECK VALVE

- Kit Includes: – 1 1/2" threaded check valve, (1) rubber boot, (2) hose clamps.
- 3-year limited warranty
- Sold as master pack of 9 pieces.

| Catalog No. | Model No. | Description |
|-------------|------------|-------------------------|
| 47668 | 66005-RDG1 | 1 1/2" sump check valve |



PROFESSIONAL INDUSTRIAL WET/DRY VACUUMS

- Four to sixteen gallon capacities.
- Proprietary motor and blower combination to maximize performance.
- Rugged polypropylene drums are impact and corrosion resistant.



| Type | No. of Models | Gallon Capacity | Page No. |
|----------------------------|---------------|-----------------|---------------|
| Standard Vacuums | 5 | 6 - 16 | 14.2 - 14.6 |
| Specialty Vacuums | 5 | 4 - 16 | 14.7 - 14.11 |
| Motor-On-Bottom Vacuums | 2 | 12 - 16 | 14.12 - 14.13 |
| 2-Stage Industrial Vacuums | 2 | 12 - 16 | 14.14 - 14.15 |
| Vacuum Accessories | 32 | – | 14.16 |
| Filters | 7 | – | 14.17 - 14.19 |
| Dust Bags | 3 | – | 14.20 |
| Air Mover | 1 | – | 14.21 |
| Vacuum Outlet Pump | 1 | – | 14.21 |

Standard Vacuums



4 GALLON PORTABLE WET/DRY VAC

Portable power doesn't get any better than the RIDGID® Model 4000RV. Pros and contractors grab the compact wet/dry vac and quickly clean up the mess with its 5.0 peak HP motor, pro hose and fine dust filter.

- **Powerful 5.0 Peak Horsepower** – High performance wet/dry vacuum in a compact package.
- **Compact Form.**
- **Longer Motor Life** – Durable, long-lasting motor backed by industry's best warranty.
- **Cord-Wrap/Large Handle** – Large carry handle provides an area for the storage of the 20' power cord.
- **Polypropylene Drum Construction** – Rugged construction to meet the higher demands found at worksites.
- **4 Gallon Drum** – Cleans up most spills and messes at work-sites and busy shops.
- **Professional Locking Hose** – The ultra-flexible professional locking hose won't pull loose during use, and is four times more durable than our standard hose. This 1⁷/₈" x 8' hose has a smooth interior surface to reduce clogging.
- **Blowing Capacity** – Use to blow leaves from walkways or decks, and debris from job sites, tools, etc.
- **Qwik Lock® Filter Fastening System** – Install or remove your filter quickly and easily and secure without tools or fasteners.
- **Includes** – Vacuum, owner's manual, 1⁷/₈" x 8' premium locking pro hose, car nozzle, noise muffler/diffuser and fine dust filter.

SPECIFICATIONS

- **Accessory Diameter** – 1⁷/₈"
- **Amperage** – 9A
- **Built-In Accessory Storage** – Yes
- **Built-In Drain** – No
- **Casters** – No
- **Filter Type** – Fine Dust Filter

| Catalog No. | Model No. | Description | Cord Length | Air Volume | Shipping Weight |
|-------------|-----------|-------------------------------|-------------|------------|-----------------|
| | | | ft. | (CFM) | lb. |
| 50313 | 4000RV | 4 Gallon Portable Wet/Dry Vac | 20 | 110 | 19 |

Standard Vacuums



6 GALLON WET/DRY VAC

The highly sought after RIDGID® Model 6000RV vac is a top performer in its class. Ideal portability, capacity, and power in a traditional, compact wet/dry vac design. Add RIDGID®'s product durability, a powerful 4.25 peak HP motor, and a pro hose and you have a vac that is ideal for pros and contractors.

- **Incredible 4.25 Peak Horsepower** – High performance wet/dry vacuum.
- **Longer Motor Life** – Durable, long-lasting motor backed by industry's best warranty.
- **360° Caster Wheels** – Provides increased maneuverability.
- **Accessory Storage** – Keeps accessories organized and close by for easy access.
- **Large Handle** – For ease of portability.
- **Polypropylene Drum Construction** – Rugged construction to meet the high demands of worksites.
- **10' Power Cord.**
- **6 Gallon Drum** – Cleans up most spills and messes at work-sites and busy shops.
- **Professional Locking Hose** – The ultra-flexible hose won't pull loose during use, and is four times more durable than our standard hose. This 1 $\frac{7}{8}$ " x 8' hose has a smooth interior surface to reduce clogging and can be stored on-board.
- **Blowing Capacity** – Blow leaves from walkways or decks, and debris from job sites, tools, etc.
- **Qwik Lock® Filter Fastening System** – Install or remove your filter quick, easy and secure without tools or fasteners.
- **Includes** – Vacuum, owner's manual, 2 extension wands, 1 $\frac{7}{8}$ " x 8' premium locking pro hose, utility nozzle and standard filter.

SPECIFICATIONS

- **Accessory Diameter** – 1 $\frac{7}{8}$ "
- **Amperage** – 8.3A
- **Built-In Accessory Storage** – Yes
- **Built-In Drain** – No
- **Casters** – Yes
- **Filter Type** – White cartridge filter

| Catalog No. | Model No. | Description | Cord Length | Air Volume | Shipping Weight |
|-------------|-----------|----------------------|-------------|------------|-----------------|
| | | | ft. | (CFM) | lb. |
| 50308 | 6000RV | 6 Gallon Wet/Dry Vac | 10 | 69 | 16 |

Standard Vacuums



12 GALLON WET/DRY VAC

The RIDGID® Model 1200RV vac is a large volume unit that delivers a powerful 5.0 peak HP. It features the rugged construction and durability that all RIDGID® tools are known for. With an 8' premium locking pro hose, this unit is a perfect for pro, contractor and industrial use.

- **Powerful 5.0 Peak Horsepower** – High performance wet/dry vacuum.
- **Longer Motor Life** – Durable, long-lasting motor backs industry's best warranty.
- **360° Caster Wheels** – Provides increased maneuverability.
- **Accessory Storage** – Keeps accessories organized and close by for easy access.
- **Cord-Wrap/Large Handle** – Large carry handle provides an area for the storage of the 15' power cord.
- **Polypropylene Drum Construction** – Rugged construction to meet the high demands of worksites.
- **12 Gallon Drum** – Cleans up large spills and messes at work-sites and busy shops.
- **Professional Locking Hose** – The ultra-flexible hose won't pull loose during use, and is four times more durable than our standard hose. This 1⁷/₈" x 8' hose has a smooth interior surface to reduce clogging and can be stored on-board.
- **Blowing Capacity** – Blow leaves from walkways or decks, and debris from job sites, tools, etc.
- **Large Drain** – Located to lowest point of drum for emptying of water.
- **Qwik Lock® Filter Fastening System** – Install or remove your filter quickly, easily and secure without tools or fasteners.
- **Includes** – Vacuum, owner's manual, 2 extension wands, 1⁷/₈" x 8' premium locking pro hose, utility nozzle, wet nozzle, car nozzle, and standard filter.

SPECIFICATIONS

- **Accessory Diameter** – 2¹/₂"
- **Amperage** – 10A
- **Built-In Accessory Storage** – Yes
- **Built-In Drain** – Yes.
- **Casters** – Yes
- **Filter Type** – Standard Filter

| Catalog No. | Model No. | Description | Cord Length | Air Volume | Shipping Weight |
|-------------|-----------|-----------------------|-------------|------------|-----------------|
| | | | ft. | (CFM) | lb. |
| 50323 | 1200RV | 12 Gallon Wet/Dry Vac | 15 | 145 | 23 |

Standard Vacuums



14 GALLON WET/DRY VAC WITH CART

The RIDGID® Model 1400RV is a 14-gallon industrial-strength wet/dry vacuum with a cart that delivers 6.0 peak HP. It features a large capacity and the rugged construction needed for pro, contractor and industrial use.

- **11.5 Amp Motor** – Durable, long-lasting motor backs industry’s best warranty.
- **6.0 pHP, 2-Stage Motor** – Creates powerful high-lift suction and more efficient air flow.
- **Sturdy Cart, Push Handle and Large Rear Wheels** – These features act together to allow the vac to travel easily up/down stairs and over rough terrain and thresholds.
- **Accessory Storage Bag** – Keeps accessories organized and close by for easy access.
- **Cord-Wrap/Large Handle** – Large carry handle provides an area for the storage of the 20’ power cord.
- **2-Piece Polypropylene Drum Construction** – Rugged construction to meet the higher demands found at work sites.
- **14 Gallon Drum** – Cleans up of large spills and messes at work sites and busy shops.
- **Sound Reduction Technology** – Scroll Noise Reduction® is a patented feature that provides quiet operation by precisely controlling the flow of air through the vac.
- **Professional Locking Hose** – The ultra-flexible hose won’t pull loose during use, and is four times more durable than our standard hose. This 2½” x 8’ hose has a smooth interior surface to reduce clogging.
- **Blowing Capacity** – Blow leaves from walkways or decks, and debris from job sites, tools, etc.
- **Oversize Drain** – Located to lowest point of drum for emptying of water.
- **Qwik Lock® Filter Fastening System** – Install or remove your filter quickly, easily and secure without tools or fasteners.
- **Includes** – Vacuum, owner’s manual, 2 extension wands, 2½” x 8’ premium locking pro hose, utility nozzle, wet nozzle, crevice tool, car nozzle and fine dust filter.

SPECIFICATIONS

- **Accessory Diameter** – 2½”
- **Amperage** – 11A
- **Built-In Accessory Storage** – Yes
- **Built-In Drain** – Yes
- **Casters** – Yes
- **Filter Type** – Fine Dust Filter

| Catalog No. | Model No. | Description | Cord Length | Air Volume (CFM) | Shipping Weight |
|-------------|-----------|---------------------------------|-------------|------------------|-----------------|
| | | | ft. | | lb. |
| 50348 | 1400RV | 14 Gallon Wet/Dry Vac with Cart | 20 | 143 | 27 |



Standard Vacuums



16 GALLON STAINLESS STEEL WET/DRY VAC WITH CART

This RIDGID® 1610RV 16 gallon stainless steel wet/dry vacuum is designed to deliver the powerful suction, large capacity, rugged construction, and excellent mobility for pro, contractor and industrial use.

- **6.5 Peak Horsepower** – High performance wet/dry vacuum provides optimum power.
- **Sturdy Cart, Push Handle and Large Rear Wheels** – These features act together to allow the vac to travel easily up/down stairs and over rough terrain and thresholds.
- **Accessory Storage Bag** – Keeps accessories organized and close by for easy access.
- **Cord-Wrap/Large Handle** – Large carry handle provides an area for the storage of the 20' power cord.
- **Stainless Steel Drum Construction** – Attractive stainless steel construction provides professional appearance.
- **16 Gallon Drum** – Cleans up large spills and messes at work-sites and busy shops.
- **Sound Reduction Technology** – Scroll Noise Reduction® is a patented feature that provides quiet operation by precisely controlling the flow of air through the vac.
- **Professional Locking Hose** – The ultra-flexible hose won't pull loose during use, and is four times more durable than our standard hose. This 2½" x 8' hose has a smooth interior surface to reduce clogging.
- **Blowing Capacity** – Blow leaves from walkways or decks, and debris from job sites, tools, etc.
- **Qwik Lock® Filter Fastening System** – Install or remove your filter quickly, easily and secure without tools or fasteners.
- **Includes** – Vacuum, 2 extension wands, 2½" x 8' premium locking pro hose, utility nozzle, wet nozzle, crevice tool, car nozzle, and fine dust filter.

SPECIFICATIONS

- **Accessory Diameter** – 2½"
- **Amperage** – 12A
- **Built-In Accessory Storage** – Yes
- **Built-In Drain** – Yes
- **Casters** – Yes
- **Filter Type** – Fine Dust Cartridge

| Catalog No. | Model No. | Description | Cord Length | Air Volume | Shipping Weight |
|-------------|-----------|---|-------------|------------|-----------------|
| | | | ft. | (CFM) | lb. |
| 50353 | 1610RV | 16 Gallon Stainless Steel Wet/Dry Vac with cart | 20 | 187 | 39 |

Specialty Vacuums



4.5 GALLON ProPack® WET/DRY VAC

The RIDGID® Model 4500RV vac has a unique, toolbox design for portability and easy storage making it ideal for contractors, pros and industrial use. The accessories, 7' expanding hose and incredible 5.0 peak HP motor combine to destroy the mess.

- 5.0 Peak Horsepower – High performance wet/dry vacuum.
- Longer Motor Life – Durable, long-lasting motor backed by industry's best warranty.
- Unique Design – Stores hose, accessories and 20' power cord inside the vac keeping everything organized and close at hand.
- Large Cushioned Handle – Portable and folds away for storage.
- Flat Top Work Surface – Increases your effective work area.
- Polypropylene Drum Construction – Rugged construction to meet the high demands of worksites.
- 4.5 Gallon Drum – Cleans up of most spills and messes at work-sites and busy shops.
- 1 7/8" Ultra-flexible Locking Hose – Won't pull loose during use; and the 2' compact hose extends to 7'.
- Blowing Capacity – Blow leaves from walkways or decks and debris from job sites, tools, etc.
- Qwik Lock® Filter Fastening System – Install or remove your filter quickly, easily and secure without tools or fasteners.
- Includes – Vacuum, owner's manual, 2 extension wands, 1 7/8" x 2-7' expanding hose, utility nozzle, dusting brush, crevice tool, and fine dust filter.

SPECIFICATIONS

- Accessory Diameter – 1 7/8"
- Amperage – 9A
- Built-In Accessory Storage – Yes
- Built-In Drain – No
- Casters – No
- Filter Type – Fine Dust Filter

| Catalog No. | Model No. | Description | Cord Length | Air Volume | Shipping Weight |
|-------------|-----------|---------------------------------|-------------|------------|-----------------|
| | | | ft. | (CFM) | lb. |
| 50318 | 4500RV | 4.5 Gallon ProPack® Wet/Dry Vac | 20 | 103 | 18 |



Specialty Vacuums



10 GALLON ProPack® Plus WET/DRY VAC

The RIDGID® 1000RV is the ultimate wet/dry vac for contractors. This 10 gallon wet/dry vacuum features a unique, toolbox design for portability and easy storage with accessories and power cord storing inside compartments on the vac. The extra sturdy cart allows you to wheel it and your tools right through the door and to the job, and the 5.0 peak HP motor provides the required suction power to tackle most messes. The Qwik Lock® fine dust filter captures everyday dirt and fine particles such as dry wall dust and is quick, easy, and secure to install or remove.

- **Powerful 5.0 Peak Horsepower** – High performance wet/dry vacuum.
- **Longer motor life** – Durable, long-lasting motor backs industry's best warranty.
- **Telescoping Handle and Large Rear Wheels** – Provide easy transportability.
- **Accessory Storage** – Storage compartments keep hose, wands, power cord, and all accessories organized and close by for quick access.
- **Polypropylene Drum Construction** – Rugged construction to meet the high demands at work sites.
- **10 Gallon Drum** – Allows clean-up of large spills and messes at work-sites and busy shops.
- **1 7/8" Ultra-flexible Locking** – The hose expands from 2-7' and won't pull loose during use. This hose offers flexibility and cleaning versatility.
- **Blowing capacity** – Use to blow leaves from walkways or decks, and debris from job sites, tools, etc.
- **Large Drain** – Located to lowest point of drum for emptying of water.
- **Qwik Lock® Filter Fastening System** – Makes installing or removing your filter quick, easy, and secure without tools or fasteners.

SPECIFICATIONS

- **Amperage** – 9A
- **Built-In Accessory Storage** – Yes
- **Built-In Drain** – Yes
- **Casters** – Rear Wheels and Telescoping Handle
- **Filter Type** – Fine Dust Filter
- **Peak Horsepower** – 5
- **Vacuum Capacity (Gallons)** – 10

| Catalog No. | Model No. | Description | Cord Length | Air Volume | Shipping Weight |
|-------------|-----------|-------------------------------------|-------------|------------|-----------------|
| | | | ft. | (CFM) | lb. |
| 50328 | 1000RV | 10 Gallon ProPack® Plus Wet/Dry Vac | 20 | 103 | 29.2 |



Specialty Vacuums



14 GALLON WITH CERTIFIED HEPA FILTRATION

The RIDGID® Model RV2400HF is a 14-gallon, 2-stage wet/dry vacuum with certified HEPA Filtration that meets EPA's definition under the RRP rule for lead paint renovations. It delivers the high-lift suction, large capacity, rugged construction for pro, contractor and industrial use.

- **3 Layers of Filtration** – Disposable high-efficiency filter bags collect larger debris. Then a washable fabric filter cover captures particles down to 0.5 microns. The certified HEPA filter then captures the smallest particulates down to 0.3 microns.
- **11.5 Amp Motor** – Drives two blower wheels to optimize suction and deliver industry-leading performance.
- **2-Stage Motor** – Creates powerful “high-lift” suction and more efficient air flow. Result – more suction power and quieter operation.
- **Longer motor life** – Over 700 hours on average.
- **On-Board Storage** – Keeps accessories organized and close by for easy access.
- **Cord-Wrap/Large Handle** – Large carry handle provides an area for the storage of the 25' power cord.
- **2-Piece Drum Construction** – Rugged construction to meet the higher demands found at worksites.
- **14 Gallon Drum** – Cleans up large spills and messes at work-sites and busy shops.
- **Sound Reduction Technology** – Scroll Noise Reduction® is a patented feature that provides quiet operation by precisely controlling the flow of air through the vac.
- **Professional Locking Hose** – The hose won't pull loose during use, and is four times more durable than our standard hose.
- **Large Built-in Drain** – Drain located to lowest point of drum for emptying of water.
- **Includes** – Vacuum, owner's manual, 2 extension wands, 2½" x 10' premium locking pro hose, utility nozzle, wet nozzle, 14" floor brush, crevice tool, muffer/diffuser, filter bag, cloth pre-filter, certified HEPA filter, “beater bar” turbo brush with connector, and dusting brush.

SPECIFICATIONS

- **Accessory Diameter** – 2½"
- **Amperage** – 11.5A
- **Built-In Accessory Storage** – Yes
- **Built-In Drain** – Yes
- **Casters** – Yes
- **Filter Type** – Fine Dust Filter

| Catalog No. | Model No. | Description | Cord Length | Air Volume | Shipping Weight |
|-------------|-----------|--------------------------------------|-------------|------------|-----------------|
| | | | ft. | (CFM) | lb. |
| 50368 | RV2400HF | 14 Gallon HEPA certified Wet/Dry Vac | 25 | 105 | 36.2 |

Specialty Vacuums



14 GALLON Smart Pulse™ WET/DRY VAC

The RIDGID® Model RV3410 is a 14-gallon, 2-stage industrial wet/dry vac with built in Smart Pulse™ self-cleaning technology to clean the dual PTFE filters. This reduces face-loading and clogged filters making it the ultimate vac for the pickup of fine dust and powders. The dual blower wheel is driven by the 11.5 amp motor and is designed to deliver powerful high-lift suction, large capacity, rugged construction, and excellent mobility for pro, contractor, industrial and commercial use.

- **Self-Cleaning Filter** – Reduce face loading with the dual PTFE filters and built in Smart Pulse™ self-cleaning technology to clean the filter.
- **11.5 Amp Motor** – Drives two blower wheels to optimize suction and deliver industry-leading performance.
- **2-Stage Motor** – Creates powerful “high-lift” suction and more efficient air flow. Result – more suction power and quieter operation.
- **Longer Motor Life** – Over 700 hours on average.
- **Push Handle and Large Rear Wheels** – These features act together to allow the vac to travel easily up/down stairs and over rough terrain.
- **Cord-Wrap/Large Handle** – Large carry handle provides an area for the storage of the 25’ power cord.
- **2-Piece Polypropylene Drum Construction** – Rugged construction to meet the higher demands found at work sites.
- **14 Gallon Drum** – Cleans up large spills and messes at work-sites and busy shops.
- **Sound Reduction Technology** – Scroll Noise Reduction® is a patented feature that provides quiet operation by precisely controlling the flow of air through the vac.
- **Large built-in drain** – Drain located to lowest point of drum for emptying of water.
- **Premium Locking Pro Hose** – The ultra-flexible hose won’t pull loose during use, and is 4x more durable than our standard hose. This 1 7/8” x 15’ hose has a smooth interior surface to reduce clogging.
- **1 7/8” x 15’ Pro Hose** – Locks securely to the vac and will not crimp.
- **Qwik Lock® Filter Fastening System** – Install or remove your filter quickly, easily and secure without tools or fasteners.
- **Includes** – Vacuum, owner’s manual, 2 PTFE coated filters, and 1 7/8” x 15’ locking hose, and diffuser.

SPECIFICATIONS

- **Accessory Diameter** – 1 7/8”
- **Amperage** – 11.5A
- **Built-In Accessory Storage** – Yes
- **Built-In Drain** – Yes
- **Casters** – Yes
- **Filter Type** – Fine Dust Cartridge

| Catalog No. | Model No. | Description | Cord Length | Air Volume | Shipping Weight |
|-------------|-----------|----------------------------|-------------|------------|-----------------|
| | | | ft. | (CFM) | lb. |
| 50373 | RV3410 | 14 Gallon Smart Pulse™ Vac | 25 | 100 | 32 |
| 51803 | VT2580 | Optional Anti-Static Hose | – | – | 4 |
| 51808 | VF3800 | PTFE Replacement Filter | – | – | 1 |

Specialty Vacuums



16 GALLON WET/DRY VAC WITH DETACHABLE BLOWER

The RIDGID® Model 1620RV is a 16 gallon wet/dry vacuum with a detachable blower that delivers powerful suction and a powerful blower in one tool. The 8' premium locking pro-hose won't pull loose during use and is 4x more durable than a standard hose. The premium pro-hose also won't kink allowing for optimum airflow. The Qwik Lock® filter captures everyday dirt, and is quick, easy and secure to install or remove. The large capacity, rugged construction, and excellent mobility are ideal for pro, contractor and industrial use.

- **Detachable Blower** – The high performance vacuum has an integrated detachable blower for maximum versatility.
- **6.5 Peak Horsepower** – High performance wet/dry vacuum provides optimum power.
- **360° Caster Wheels** – Provides increased maneuverability.
- **On Board Accessory Storage** – Keeps accessories organized and close at hand for easy access.
- **Quick Release Cord-Wrap** – The cord-wrap not only stores the 20' power cord, but the tab rotates to quickly release the cord.
- **2-Piece Polypropylene Drum Construction** – Rugged construction to meet the higher demands found at work sites.
- **16 Gallon Drum** – Cleans up large spills and messes at work-sites and busy shops.
- **Sound Reduction Technology** – Scroll Noise Reduction® is a patented feature that provides quiet operation by precisely controlling the flow of air through the vac.
- **Professional Locking Hose** – The ultra-flexible hose won't pull loose during use, and is four times more durable than our standard hose. This 1 7/8" x 8' hose has a smooth interior surface to reduce clogging.
- **Large Drain** – Located to lowest point of drum for emptying of water.
- **Qwik Lock® Filter Fastening System** – Makes installing or removing your filter quickly, easily and secure without tools or fasteners.
- **Includes** – Vacuum, owner's manual, 2 extension wands, 1 7/8" x 8' premium locking pro hose, locking blowing wand, utility nozzle, wet nozzle, car nozzle, and fine dust filter.

SPECIFICATIONS

- **Accessory Diameter** – 1 7/8"
- **Amperage** – 12A
- **Built-In Accessory Storage** – Yes
- **Built-In Drain** – Yes
- **Casters** – Yes
- **Filter Type** – Cartridge

| Catalog No. | Model No. | Description | Cord Length | Air Volume | Shipping Weight |
|-------------|-----------|--|-------------|------------|-----------------|
| | | | ft. | (CFM) | lb. |
| 50343 | 1620RV | 16 Gallon Wet/Dry Vac with Detachable Blower | 20 | 172 | 29 |



Motor-On-Bottom Vacuums



12 GALLON MOTOR-ON-BOTTOM WET/DRY VAC

The RIDGID® 1250RV has a unique motor-on-bottom, design delivering 6.5 peak HP. This new design provides stability and makes accessing the filter and emptying the drum easier. With an 8' premium locking pro hose, this unit is perfect for pro, contractor, and industrial use.

- **Powerful 6.5 Peak Horsepower** – High performance wet/dry vacuum.
- **Longer motor life** – Durable, long-lasting motor backs industry's best warranty.
- **360° Caster Wheels** – Provides increased maneuverability.
- **Accessory Storage** – Keeps accessories organized and close by for easy access.
- **Cord Storage** – Cord hook on back provides for storage of 20' power cord.
- **Polypropylene Drum Construction** – Rugged construction to meet the higher demands found at worksites.
- **12 Gallon Drum** – Allows clean-up of large spills and messes at work sites and busy shops.
- **Professional Locking Hose** – The ultra-flexible hose won't pull loose during use, and is 4x more durable than our standard hose. This 1 7/8" x 8' hose has a smooth interior surface to reduce clogging and can be stored on-board.
- **Blowing capacity** – Use to blow leaves from walkways or decks, and debris from job sites, tools, etc.
- **Large Drain** – Located to lowest point of drum for emptying of water.
- **Qwik Lock® Filter Fastening System** – Makes installing or removing your filter quick, easy, and secure without tools or fasteners.
- **Foot activated power switch** – Makes turning on the vac easy when your hands are full.
- **Motor-On-Bottom design** – You'll never have to place a dirty filter on your clean work area again.
- **Includes** – Vacuum, owner's manual, utility nozzle, wet nozzle, car nozzle, 2 wands, crevice tool, diffuser, and fine dust filter.

SPECIFICATIONS

- **Amperage** – 12A
- **Built-In Accessory Storage** – Yes
- **Built-In Drain** – Yes
- **Casters** – Yes
- **Filter Type** – Fine Dust Filter

| Catalog No. | Model No. | Description | Cord Length ft. | Air Volume (CFM) | Shipping Weight lb. |
|-------------|-----------|---------------------------------------|-----------------|------------------|---------------------|
| 50333 | 1250RV | 12 Gallon Motor-On-Bottom Wet/Dry Vac | 20 | 190.7 | 30 |



Motor-On-Bottom Vacuums



16 GALLON MOTOR-ON-BOTTOM WET/DRY VAC

The RIDGID® Model 1650RV is a 16-gallon industrial wet/dry vacuum featuring an innovative motor-on-bottom design that delivers incredible performance, improved stability, noise reduction, large capacity, rugged construction, and excellent mobility for pro, contractor and industrial use.

- **Motor on Bottom Design** – Accessing filter and emptying drum cleaner and easier.
- **Foot-Activated Switch** – Hands free operation with foot pedal power switch.
- **6.5 Peak Horsepower motor** – With nearly 25% more power than previous models.
- **Quick-Access Debris Door** – Dump larger debris into the drum and continue working.
- **Qwik Lock® Filter Fastening System** – Install or remove your filter quickly, easily and secure without tools or fasteners.
- **Longer Motor Life** – Durable, long-lasting motor backs the industry’s best warranty.
- **Sturdy Cart, Push Handle and Large Rear Wheels** – These features act together to allow the vac to travel easily up/down stairs and over rough terrain.
- **Accessory Stretch Caddy** – Keeps accessories close by and locked in when emptying.
- **Cord-hook** – Keeps the 20’ power cord with ALCI outlet neatly stored on-board.
- **2-Piece Drum Construction** – Rugged construction to meet the higher demands found at worksites.
- **16 Gallon Drum** – Cleans up of large spills and messes at work-sites and busy shops.
- **Sound Reduction Technology** – Scroll Noise Reduction® is a patented feature that provides quiet operation by precisely controlling the flow of air through the vac. Additionally with the motor-on-bottom design, motor noise is hampered.
- **Professional Locking Hose** – The hose won’t pull loose during use, and is four times more durable than our standard hose.
- **Blowing Capacity** – Blow leaves from walkways or decks, and debris from job sites, tools, etc.
- **Large Built-in Drain** – Drain located to lowest point of drum for emptying of water.
- **Includes** – Vacuum, owner’s manual, 2 extension wands, 2½” x 8’ premium locking pro hose, utility nozzle, wet nozzle, crevice tool, car nozzle, noise muffler/diffuser, and fine dust filter.

SPECIFICATIONS

- **Accessory Diameter** – 2½"
- **Amperage** – 12A
- **Built-In Accessory Storage** – Yes
- **Built-In Drain** – Yes
- **Casters** – Yes.
- **Cord Length** – 20'
- **Filter Type** – Fine Dust Filter

| Catalog No. | Model No. | Description | Cord Length | Air Volume | Shipping Weight |
|-------------|-----------|---------------------------------------|-------------|------------|-----------------|
| | | | ft. | (CFM) | lb. |
| 50338 | 1650RV | 16 Gallon Motor-On-Bottom Wet/Dry Vac | 20 | 193 | 32.3 |

2-Stage Industrial Vacuums



14 GALLON 2-STAGE WET/DRY VAC

The RIDGID® Model RV2400A is a 14-gallon, 2-stage industrial wet/dry vac delivering high-lift suction, large capacity, rugged construction, and excellent mobility for pro, contractor, and industrial use. The dual blower wheel is driven by an 11.5 amp motor to efficiently handle the toughest wet or dry work site cleanup tasks.

- **11.5 Amp Motor** – Drives two blower wheels to optimize suction and deliver industry-leading performance.
- **6.5 pHP, 2-Stage Motor** – Creates powerful “high-lift” suction and more efficient air flow. Result – more suction power and quieter operation.
- **Longer Motor Life** – Over 700 hours on average.
- **Sturdy Cart, Push Handle and Large Rear Wheels** – These features act together to allow the vac to travel easily up/down stairs and over rough terrain and thresholds.
- **Accessory Storage Bag** – Keeps accessories organized and close by for easy access.
- **Cord-Wrap/Large Handle** – Large carry handle provides an area for the storage of the 25' power cord.
- **2-Piece Polypropylene Drum Construction** – Rugged construction to meet the higher demands found at worksites.
- **14 Gallon Drum** – Cleans up large spills and messes at work-sites and busy shops.
- **Sound Reduction Technology** – Scroll Noise Reduction® is a patented feature that provides quiet operation by precisely controlling the flow of air through the vac.
- **Professional Locking Hose** – The ultra-flexible hose won't pull loose during use, and is four times more durable than our standard hose. This 2½" x 10' hose connects to 2½" accessories and has a smooth interior surface to reduce clogging.
- **Blowing Capacity** – Blow leaves from walkways or decks, and debris from job sites, tools, etc.
- **Large Built-In Drain** – Located to lowest point of drum for emptying of water.
- **Qwik Lock® Filter Fastening System** – Install or remove your filter quickly, easily and secure without tools or fasteners.
- **Includes** – Vacuum, owner's manual, 2 extension wands, 2½" x 10' premium locking pro hose, utility nozzle, wet nozzle, floor brush, crevice tool, muffler/diffuser and fine dust filter.

SPECIFICATIONS

- **Accessory Diameter** – 2½"
- **Amperage** – 11.5A
- **Built-In Accessory Storage** – Yes
- **Built-In Drain** – Yes
- **Casters** –Yes
- **Filter Type** – Fine Dust Filter

| Catalog No. | Model No. | Description | Cord Length | Air Volume | Shipping Weight |
|-------------|-----------|-------------------------------|-------------|------------|-----------------|
| | | | ft. | (CFM) | lb. |
| 50358 | RV2400A | 14 Gallon 2-Stage Wet/Dry Vac | 25 | 105 | 35.4 |

2-Stage Industrial Vacuums



16 GALLON 2-STAGE WET/DRY VAC

The RIDGID® Model RV2600B is a 16-gallon 2-stage industrial wet/dry vacuum that delivers high-lift suction, large capacity, rugged construction, excellent mobility and upgraded accessories for pro, contractor and industrial use.

- **11.5 Amp Motor** – Drives two blower wheels to optimize suction and deliver industry-leading performance.
- **2-Stage Motor** – Creates powerful “high-lift” suction and more efficient air flow. Result – more suction power and quieter operation.
- **Longer Motor Life** – Over 700 hours on average.
- **Sturdy Cart, Push Handle and Large Non-Marring Wheels** – These features act together to allow the vac to travel easily up/down stairs and over rough terrain.
- **Accessory Storage Bag** – Keeps accessories organized and close by for easy access.
- **Cord-Wrap/Large Handle** – Large carry handle provides an area for the storage of the 25' power cord.
- **2-Piece Drum Construction** – Rugged construction to meet the higher demands found at work sites.
- **16 Gallon Drum** – Cleans up large spills and messes at work-sites and busy shops.
- **Sound Reduction Technology** – Scroll Noise Reduction® is a patented feature that provides quiet operation by precisely controlling the flow of air through the vac.
- **Professional Locking Hose** – The hose won't pull loose during use, and is four times more durable than our standard hose.
- **Large Built-in Drain** – Drain located to lowest point of drum for emptying of water.
- **Includes** – Vacuum, owner's manual, 2 steel extension wands, 1 $\frac{7}{8}$ " x 10' premium locking pro hose, floor tool with 3 inserts (floor nozzle, squeegee and carpet cleaning nozzle), dusting brush, crevice tool, claw nozzle, muffler/diffuser, and fine dust filter.

SPECIFICATIONS

- **Accessory Diameter** – 1 $\frac{7}{8}$ "
- **Amperage** – 11.5A
- **Built-In Accessory Storage** – Yes
- **Built-In Drain** – Yes
- **Casters** – Yes
- **Cord Length** – 25'
- **Filter Type** – Fine Dust Filter

| Catalog No. | Model No. | Description | Cord Length ft. | Air Volume (CFM) | Shipping Weight lb. |
|-------------|-----------|-------------------------------|--------------------|---------------------|------------------------|
| 50363 | RV2600B | 16 Gallon 2-Stage Wet/Dry Vac | 25 | 105 | 38 |

Accessories



1 7/8" Accessories

| Catalog No. | Model No. | Description |
|-------------|-----------|----------------------------|
| 29848 | VT1781 | Car Nozzle |
| 31718 | VT1701 | Dusting Brush |
| 31723 | VT1702 | Crevice Tool |
| 31728 | VT1708 | Extension Wand |
| 31733 | VT1709 | Utility Nozzle |
| 31738 | VT1710 | Wet Nozzle |
| 40163 | VT1712 | Crevice Tool/Dusting Brush |
| 40168 | VT1714 | Floor Brush |

2 1/2" Accessories

| Catalog No. | Model No. | Description |
|-------------|-----------|-------------------|
| 72887 | VT2501 | Dusting Brush |
| 72902 | VT2508 | Extension Wands |
| 72907 | VT2509 | Utility Nozzle |
| 72912 | VT2510 | Wet Nozzle |
| 72922 | VT2514 | Floor Brush |
| 72932 | VT2502 | Crevice Tool |
| 72937 | VT2503 | Blower/Car Nozzle |

Kits/Hoses/Etc. Accessories

| Catalog No. | Model No. | Description |
|-------------|-----------|---|
| 24608 | VT2570 | 4X Pro Hose Replacement |
| 26573 | VT2530 | Multi-Surface Nozzle with Brush |
| 26578 | VT2540 | Claw Nozzle |
| 31713 | VT1720 | 1 7/8" x 7' Wet/Dry Vac Hose Kit |
| 31743 | VT1755 | 3 Piece Adapter Kit |
| 32703 | VT2575 | Heavy Duty Cleaning Kit: 12 Piece Kit w/Stainless Steel Extension Wands |
| 41598 | VT2561 | Filter Nut/Drain Cap Combo |
| 41603 | VT2571 | Turbo "Beater Bar" Kit |
| 72897 | VT2520 | 2 1/2" x 7' Universal Vac Hose |
| 72927 | VT2525 | Muffler/Diffuser |

Replacement 2-Stage Service Parts

| Catalog No. | Model No. | Description |
|-------------|-----------|--------------------------------------|
| 31073 | 832077 | Nozzle Master |
| 31078 | 832079 | Floor Brush Insert |
| 31083 | 832080 | Carpet Insert |
| 31088 | 832078 | Squeegee Insert |
| 31103 | 832068 | Extension Handle Assembly - Curved |
| 31108 | 832069 | Extension Handle Assembly - Straight |

Filters

**EVERYDAY DIRT 1-LAYER PLEATED PAPER FILTER**

The RIDGID® 1-layer replacement wet/dry vac filter is great for everyday dirt. Everyday dirt is best described as sawdust or typical debris found in a basement, garage or vehicle. With its patented Qwik Lock™ feature, it simply snaps on or off the vacuum for easy cleaning.

- Washable and reusable.
- Includes 1 filter per package.

SPECIFICATIONS

- Best for:
 - Sawdust
 - Typical basement, garage, or car dirt
- Fits vac sizes – 5-20 gallons

| Catalog No. | Model No. | Description |
|-------------|-----------|---|
| 72947 | VF4000 | Everyday Dirt Filter - White; Fits 5-20 gallon vacs |

**FINE DUST 3-LAYER PLEATED PAPER FILTER**

The RIDGID® 3-layer pleated paper filter features a double-pleated design that captures fine particles such as dust, drywall sanding and fireplace ash. With its patented Qwik Lock™ feature, it simply snaps on or off the vacuum for easy cleaning.

SPECIFICATIONS

- Washable and reusable.
- Includes 1 filter per package.
- Best for:
 - Sawdust
 - Typical basement, garage, or car dirt
 - Drywall dust
 - Cement dust
 - Cold ashes (fireplace, bbq grill)
 - Fine powders (flour, talcum powder, baby powder, chalk)
- Fits vac sizes – 5-20 gallons

| Catalog No. | Model No. | Description |
|-------------|-----------|-------------------------|
| 72952 | VF5000 | Fine Dust Filter - Blue |

**FINE DUST 3-LAYER PLEATED PAPER FILTER FOR 3.0 GAL. TO 4.5 GAL. RIDGID WET DRY VACS**

The RIDGID 3-Layer fine dust replacement filter features 3 layers of filtering material that captures particles too small to be seen by the naked eye. The pleated design offers a large surface area to trap superfine dust and dirt.

SPECIFICATIONS

- Captures 99% of all particles 1/2 micron and larger.
- Great for picking up cold fireplace ash, fine dust and everyday dirt.
- Fits most RIDGID wet/dry vacs.
- Fully washable and reusable

| Catalog No. | Model No. | Description |
|-------------|-----------|-------------------------------------|
| VF3500RT | VF3500 | Half Height Fine Dust Filter - Blue |

Filters



WET APPLICATION FILTER

The VF7000 is designed for high-volume liquid pickup. This filter adds protection for your vac during wet pick-up by keeping water-borne debris out of the motor. With its patented Qwik Lock™ feature, it simply snaps on or off the vacuum for easy cleaning.

- Washable and reusable.
- Includes 1 filter per package.

SPECIFICATIONS

- Best for – wet pick-up only
- High-volume liquids
- Water-borne debris
- Fits vac sizes – 5-20 gallons

| Catalog No. | Model No. | Description |
|-------------|-----------|------------------------|
| 40158 | VF7000 | Wet Application Filter |



5-LAYER ALLERGEN FILTER

The RIDGID® 5-Layer replacement allergen filter is made from HEPA-rated material and removes 99.97% of all particles 0.3 microns and larger from the air. Allergens cleaned from the air might include particles such as pet dander and pollen. With its patented Qwik Lock™ feature, it simply snaps on or off the vacuum for easy cleaning.

- Washable and reusable.
- Includes 1 filter per package.
- Not EPA RRP qualified.

SPECIFICATIONS

- Best for:
 - Sawdust
 - Typical basement, garage, or car dirt
 - Drywall dust
 - Cement dust
 - Cold ashes (fireplace, bbq grill)
 - Fine powders (flour, talcum powder, baby powder, chalk)
 - Pet dander
 - Pollens
 - Allergens
 - Fine indoor particles (upholstery, dust mites, mold spores, dryer lint, furnace filter)
- Fits vac sizes – 5-20 gallons.
- Not EPA RRP qualified.

| Catalog No. | Model No. | Description |
|-------------|-----------|---------------------------|
| 97457 | VF6000 | HEPA Media Filter - Green |

Filters



CERTIFIED HEPA FILTER AND PRE-FILTER

New EPA regulation, now in effect requires the use of a certified HEPA filtration vac, along with other specific cleaning techniques. This certified HEPA Filter is 99.97% efficient at filtering particulates down to 0.3 microns in size when used in conjunction with the RIDGID RV2400HF wet/dry Vacuum. The filter is water resistant and durable for easy cleaning and reuse.

When used in conjunction with the RIDGID vac, RV2400HF, the vacuum system is HEPA certified for EPA cleanup under the remodel, repair, and painting (RRP) rule.

- Fits all RIDGID vacs 5 gallons and larger.
- Cleans the air by filtering 99.97% of particles as small as 0.3 microns.
- Filter is washable and reusable.
- Combined use of this filter and the high-efficiency filter bag, WD3502, will extend the life of your HEPA filter.

| Catalog No. | Model No. | Description |
|-------------|-----------|--------------------------------------|
| 40068 | HF1000 | Certified HEPA Filter and Pre-Filter |



CERTIFIED HEPA FILTER AND PRE-FILTER

The HF0500 Pre-Filter is the perfect companion to the Certified HEPA filter found on the RIDGID RV2400HF wet/dry vac with Certified HEPA Filtration. The Pre-Filter is a washable and reusable fabric filter cover that blocks a large portion of the material that might otherwise clog the Certified HEPA filter.

- Incorporates a sewn in clamp which allows a secure fit around the HEPA filter.
- Pre-filter is washable and reusable.
- Use of the pre-filter can prolong the life of the certified HEPA filter by reducing it's need for cleaning.
- Use of the pre-filter helps maintain vac performance and efficiency.

| Catalog No. | Model No. | Description |
|-------------|-----------|---------------------------|
| 40073 | HF0500 | Certified HEPA Pre-Filter |

Dust Bags



HIGH-EFFICIENCY DUST BAGS - VF3501

The RIDGID® High-Efficiency Dust Bag helps you clean up dry debris such as sawdust or drywall dust while keeping the vacuum drum clean and extending the life of your cartridge filter.

- Keeps the inside of the vac drum clean.
- Includes 2 filter collection bags.
- Fits 4 to 5 gallon RIDGID wet/dry vacs.
- Easily discarded.

| Catalog No. | Model No. | Description |
|-------------|-----------|-------------------------------------|
| 23738 | VF3501 | Dust Bag Filter Fits 3 - 4.5 Gallon |



HIGH-EFFICIENCY DUST BAGS - VF3502

The RIDGID® High-Efficiency Dust Bag helps you clean up dry debris such as sawdust or drywall dust while keeping the vacuum drum clean and extending the life of your cartridge filter.

- Keeps the inside of the vac drum clean.
- Includes 2 filter collection bags.
- Fits 12 to 16 gallon RIDGID wet/dry vacs.
- Easily discarded.

| Catalog No. | Model No. | Description |
|-------------|-----------|-------------------------------------|
| 23743 | VF3502 | Dust Bag Filter Fits 12 - 16 Gallon |



HIGH-EFFICIENCY DUST BAGS - VF3503

The RIDGID® High-Efficiency Dust Bag helps you clean up dry debris such as sawdust or drywall dust while keeping the vacuum drum clean and extending the life of your cartridge filter.

- Includes 2 filter collection bags.
- Fits 6 to 10 gallon RIDGID wet/dry vacs.
- Easily discarded.

| Catalog No. | Model No. | Description |
|-------------|-----------|------------------------------------|
| 40153 | VF3503 | Dust Bag Filter Fits 6 - 10 Gallon |

Air Mover



PROFESSIONAL PORTABLE AIR MOVER

The RIDGID® AM2560 Air Mover can be used to dry wet floors, wet carpet, and any water damaged areas. The air mover also can be used to dry shampooed upholstery, dry drywall mud, and provide ventilation.

- New, professional styled bold color signals caution while drying slippery floors.
- Professional grade durable, high impact housing; stacks easily.
- For residential and commercial use.
- Long 30' power cord for extended reach with a built-in cord wrap.
- Heavy duty 0.4 HP induction motor with three airflow speed settings (3.0 Amp, 2.7 Amp, 2.2 Amp) generates up to 1625 CFM.

SPECIFICATIONS

- Motor – 0.4 HP, 3.0 AMP
- Speeds – 3
- Power Cord – 30'
- Weight – 33 lbs.

| Catalog No. | Model No. | Description | Shipping Weight | | |
|-------------|-----------|-------------|--------------------|-----|-------|
| | | | Cord Length ft. | lb. | kg |
| 41438 | AM2560 | Air Mover | 30 | 33 | 16.00 |

Quick Connect Pump Accessory



QUICK CONNECT PUMP

The pump enables most RIDGID® wet/dry vacuums with a drain to pump 10 Gal. per minute of water from the vacuum drum up to 40 ft. high. Use any standard 5/8" garden hose to evacuate the water.

| Catalog No. | Model No. | Description | Shipping Weight | | |
|-------------|-----------|--------------------|---------------------|-----|-----|
| | | | Capacity GPH G/h | lb. | kg |
| 26453 | VP2000 | Quick Connect Pump | 600* | 2 | 0.9 |

*Capacity in gallons per hour at zero foot discharge height.



| | | | |
|--|-------|---|-------|
| # | | | |
| ¼ HP Auto ON/OFF Dewatering Pump | 13.44 | Compact Series Jaws for ProPress® System | 10.7 |
| ¼ HP Auto ON/OFF Dewatering Pump w/Freeze Protection | 13.45 | Compact Series Jaws For PureFlow™ System | 10.7 |
| ¼ HP Dewatering Pump | 13.44 | Compound Leverage Wrenches | 1.6 |
| ½ HP Dewatering Pump | 13.44 | Conduit Benders | 11.12 |
| 1½" Check Valve | 13.47 | Conduit Sizing Tool | 3.21 |
| 1½" Threaded Check Valve | 13.47 | Constant Swing Tubing Cutters | 3.15 |
| 2-in-1 Close Quarters AUTOFEED® Cutter | 3.15 | Conveyor Head Pipe Stands | 2.4 |
| 2" Check Valve | 13.47 | Copper Cleaning Brush & Machine Accessories | 3.21 |
| 4 Gallon Portable Wet/Dry Vac | 14.2 | Copper Cleaning Brushes | 3.21 |
| 4-Wheel Pipe Cutters | 3.3 | Copper Cutting Prep Machines | 3.12 |
| 4.5 Gallon ProPack® Wet/Dry Vac | 14.7 | Core Drill Bits | 6.7 |
| 4P-6 4PIN™ Dieless Crimp Head | 11.4 | Core Drilling | 6.7 |
| 5-Layer Allergen Filter | 14.18 | CS65 Digital Reporting Monitor | 12.17 |
| 6 Gallon Wet/Dry Vac | 14.3 | Cutting & Drilling | 6.1 |
| 6 mm Diameter Imager Head Accessory | 12.25 | Cutting Oil | 4.12 |
| 10 GALLON ProPack® Plus WET/DRY VAC | 14.8 | D | |
| 12 Gallon Motor-On-Bottom Wet/Dry Vac | 14.12 | Deburring Tools | 3.22 |
| 12 Gallon Wet/Dry Vac | 14.4 | Digital Interfaces | 12.18 |
| 122XL Cutting and Prep Machine | 3.12 | Drain & Sewer Video Inspection | 12.6 |
| 122XL Copper Cutting and Prep Machine | 3.13 | Drain Cleaning | 13.1 |
| 127 Inner-Outer Reamer | 3.22 | Drum Machines | 13.14 |
| 14 Gallon 2-Stage Wet/Dry Vac | 14.14 | Dry Cut Saw / Model 614 | 3.11 |
| 14 Gallon HEPA certified Wet/Dry Vac | 14.9 | Dry Cut Saws | 3.11 |
| 14 Gallon Smart Pulse Vac | 14.10 | Dust Bags | 14.2 |
| 14 Gallon Smart Pulse™ Wet/Dry Vac | 14.1 | E | |
| 14 Gallon Wet/Dry Vac with Cart | 14.5 | Electrical Tools | 11.1 |
| 14 Gallon with Certified HEPA Filtration | 14.9 | Enclosed Feed Tubing Cutters | 3.16 |
| 16 Gallon 2-Stage Wet/Dry Vac | 14.15 | Enclosed Ratchet Threader Sets | 4.3 |
| 16 Gallon Motor-On-Bottom Wet/Dry Vac | 14.13 | End Pipe Wrenches | 1.4 |
| 16 Gallon Stainless Steel Wet/Dry Vac with Cart | 14.6 | Everyday Dirt 1-Layer Pleated Paper Filter | 14.17 |
| 16 Gallon Wet/Dry Vac with Detachable Blower | 14.11 | Exposed Ratchet Bolt Threader Sets | 4.4 |
| 238-P Powered Soil Pipe Cutter | 3.5 | Exposed Ratchet Threader Sets | 4.3 |
| 300 Series Plumbing Benders | 8.2 | F | |
| 345 Manual Flare Tools | 8.7 | F-Series Vises | 7.2 |
| 400 Series Instrument Benders | 8.2 | Faucet & Sink Installer | 1.9 |
| 1450 Pressure Test Pump | 9.2 | Fiberglass Folding Rules | 7.7 |
| 223S/227S Inner-Outer Reamer | 3.22 | Filters and Accessories | 14.17 |
| 600 Series Heavy-Duty Instrument Benders | 8.3 | Fine Dust 3-Layer Pleated Paper Filter | 14.17 |
| 600-I Hand-Held Power Drive | 4.13 | Flaring Tools | 8.6 |
| 690-I Hand-Held Power Drive | 4.14 | Flat Sewer Tape | 13.7 |
| 819 Nipple Chuck Kit | 4.31 | Floating Transmitter | 12.4 |
| 915 Roll Groover | 5.3 | Foam Core Cutter | 3.21 |
| 918 Roll Groover | 5.6 | Folding Rulers | 7.7 |
| 918-I Roll Groover | 5.7 | Forged Anvils | 7.3 |
| 920 Roll Groover | 5.8 | G | |
| 975 Combo Roll Groover | 5.4 | Geared Ratchet Tube Benders | 8.4 |
| A | | Geared Threader Accessories | 4.1 |
| Adjustable Pipe Supports | 2.5 | General Tools | 7.1 |
| Adjustable Stand with Steel Rollers | 2.5 | Grappler Hook | 13.7 |
| Adjustable Wrenches | 1.7 | H | |
| AdvanTEXT™ Water Sensor | 13.46 | Hammer-Type Flaring Tools | 8.8 |
| Air Mover | 14.21 | Hammers | 7.5 |
| Aluminum End Wrenches | 1.4 | Hand Spinners | 13.8 |
| Aluminum Level | 7.4 | Hand-Held Diagnostics | 12.25 |
| Aluminum Offset Pipe Wrenches | 1.5 | Hand-Held Power Drives | 4.13 |
| Aluminum RapidGrip® Wrenches | 1.3 | Hand-Held Video Inspection | 12.21 |
| Aluminum Straight Pipe Wrenches | 1.2 | HC300 Hole Cutting Tool | 6.2 |
| Anvils | 7.3 | HC450 Hole Cutting Tool | 6.3 |
| ASTM F 1807 PEX Crimp Tools | 10.12 | Heavy Duty Flare Tools | 8.8 |
| Auto-Clean™/K-30 Sink Machine | 13.9 | Heavy-Duty Aluminum Pipe Wrenches | 1.2 |
| B | | Heavy-Duty Offset Pipe Wrenches | 1.5 |
| B-500 Transportable Pipe Beveller | 3.23 | Heavy-Duty Pipe Cutters | 3.2 |
| Ball Transfer Head | 2.4 | Heavy-Duty Straight Pipe Wrenches | 1.2 |
| Basin Wrenches | 1.8 | Heavy-Wall Conduit Benders | 11.12 |
| Bench Chain Vises | 2.2 | Hex Wrenches | 1.5 |
| Bench Vises | 7.2 | High-Efficiency Dust Bags - VF3501 | 14.2 |
| Bench Yoke Vises | 2.3 | High-Efficiency Dust Bags - VF3502 | 14.2 |
| Bending & Forming | 8.1 | High-Efficiency Dust Bags - VF3503 | 14.2 |
| Bi-Metal Hack Saw Blades | 7.6 | Hinged Pipe Cutters | 3.3 |
| Bolt Cutters | 7.13 | Hole Cutting | 6.2 |
| C | | Hole Saw Arbors | 6.4 |
| Cable Cutters | 11.10 | Hole Saw Kits | 6.4 |
| Cable Trimmers | 11.11 | Hole Saws | 6.5 |
| Carrying Cases | 4.4 | Hydraulic Bender & Accessories | 8.8 |
| Certified HEPA Filter and Pre-Filter | 14.19 | Hydraulic Benders - Tip-Up Wing | 8.8 |
| Chain Tonges | 1.7 | Hydraulic Knockout Kits | 11.7 |
| Chain Wrenches | 1.6 | I | |
| Close Quarters Tubing Cutters | 3.14 | Inner Tube Core Barrel Wrench | 1.3 |
| Compact Series ASTM F 1807 Jaws (For PEX Tubing) | 10.8 | Inner-Outer Copper Cleaning Brush | 3.21 |
| Compact Series Jaws | 10.7 | Inspection Software & Business Tools | 12.19 |
| | | Interchangeable Heads | 11.4 |
| | | Internal Tubing Cutters | 3.17 |
| | | Internal Wrenches | 1.9 |
| | | K | |
| | | K-1000 Rodder Machine | 13.36 |
| | | K-1500 Sectional Machine | 13.3 |
| | | K-1500G Sectional Machine | 13.34 |
| | | K-1500SP Sectional Machine | 13.32 |
| | | K-25 Hand Spinner | 13.8 |
| | | K-26 Hand Spinner | 13.8 |
| | | K-3 and K-6 Toilet Augers | 13.6 |
| | | K-3800 Drum Machine | 13.16 |
| | | K-40 Sink Machine | 13.1 |
| | | K-400 Drum Machine | 13.14 |
| | | K-45 Sink Machine | 13.12 |
| | | K-5 Grappler Hook | 13.7 |
| | | K-50 Sectional Machine | 13.26 |
| | | K-60SP Sectional Machine | 13.28 |
| | | K-6200 Drum Machine | 13.18 |
| | | K-750 Drum Machine | 13.2 |
| | | K-7500 Drum Machine | 13.22 |
| | | K-750R Drum Machine | 13.24 |
| | | KJ-1350 Water Jetter | 13.38 |
| | | KJ-1750 Water Jetter | 13.39 |
| | | KJ-2200 Water Jetter | 13.4 |
| | | KJ-3100 Water Jetter | 13.42 |
| | | Knockout Kits | 11.7 |
| | | Knockout Sets | 11.8 |
| | | Kwik-Spin® Hand Spinner with AUTOFEED® | 13.9 |
| | | L | |
| | | Laptop Interface | 12.18 |
| | | Large Diameter Pipe Stand | 2.5 |
| | | Levels | 7.4 |
| | | Lever Benders | 8.2 |
| | | Locating | 12.29 |
| | | M | |
| | | Machined Aluminum Level | 7.4 |
| | | Magnetic Torpedo Level | 7.4 |
| | | Manual Cable Cutters | 11.1 |
| | | Manual Hydraulic Crimp Tools | 11.9 |
| | | Manual Knockout Kits | 11.7 |
| | | Manual Press Tools | 10.12 |
| | | Manual Ratchet Threaders | 4.3 |
| | | Manual Receding Threaders | 4.8 |
| | | MegaPress Jaws & Press Rings | 10.11 |
| | | micro CA-100 Inspection Camera | 12.23 |
| | | micro CA-25 Digital Inspection Camera | 12.22 |
| | | micro CA-300 Inspection Camera | 12.24 |
| | | micro CD-100 Combustible Gas Detector | 12.29 |
| | | micro IR-200 Infrared Thermometer | 12.26 |
| | | micro LM-100 Laser Distance Meter | 12.27 |
| | | micro LM-400 Advanced Laser Distance Meter | 12.28 |
| | | Model 10 Screw Extractor Set | 7.11 |
| | | Model 1215 Threading Machine | 4.22 |
| | | Model 1224 Threading Machine | 4.26 |
| | | Model 212 Pro Arc Saw | 7.6 |
| | | Model 25 Screw and Pipe Extractor Set | 7.12 |
| | | Model 258 Power Pipe Cutter | 3.9 |
| | | Model 258XL Power Pipe Cutter | 3.1 |
| | | Model 300 Compact Threading Machine | 4.23 |
| | | Model 300 Power Drive | 4.16 |
| | | Model 300 Power Drive Complete | 4.17 |
| | | Model 418 Oiler | 4.12 |
| | | Model 456 Tri-Bender | 8.3 |
| | | Model 535 Threading Machine | 4.2 |
| | | Model 535A Automatic Threading Machine | 4.18 |
| | | Model 700 Power Drive | 4.15 |
| | | Model S Tube Expander | 8.5 |
| | | Model SF-2500 SuperFreeze | 9.4 |
| | | Models KT-190 / KT-200 Pipe Thawers | 9.5 |
| | | Monitors & Recorders | 12.14 |
| | | MR-10 Magnetic Locator | 12.37 |
| | | Multi-Purpose Screwdriver | 7.8 |
| | | N | |
| | | NaviTrack Brick - 5 Watt | 12.39 |
| | | NaviTrack II Locator | 12.37 |
| | | NaviTrack Line Transmitter - 10 Watt | 12.39 |
| | | NaviTrack Scout® Locator | 12.38 |
| | | NaviTrack® Locators | 12.38 |
| | | NaviTrack® Transmitters | 12.39 |
| | | Nipple Chucks / Adapters | 4.31 |
| | | No. 206 Soil Pipe Cutter | 3.4 |

ALPHABETICAL INDEX

| | | | | | |
|--|-------|---|-------|----------------------------------|-------|
| No. 226 In-Place Soil Pipe Cutter | 3.4 | Rodder Machines | 13.36 | Tube Repair & Joining | 9.1 |
| No. 228 Soil Pipe Assembly Tool | 3.6 | Roll Grooving | 5.1 | Tubing Cutters | 3.14 |
| No. 246 Soil Pipe Cutter | 3.5 | Roller Head Pipe Stands | 2.4 | Twist Drills | 7.12 |
| No. 276 Soil Pipe Cutter | 3.6 | RP 200-B Press Tool | 10.4 | U | |
| No. 575 EMT Sizing Tool for Conduit | 3.21 | RP 210-B Press Tool | 10.5 | Utility Locating | 12.31 |
| No. 606 Standard Shape with Tray | 7.7 | RP 340 Press Tool | 10.6 | Utility Pumps | 13.44 |
| No. 65R-C Manual Receding Threader | 4.8 | RT-100 Electric Soldering Gun | 9.3 | Utility Transfer Pump | 13.45 |
| No. 65R-TC Manual Receding Threader | 4.8 | RT-175 Electric Soldering Gun | 9.3 | V | |
| No. 87 ACSR Cable Trimmer | 11.11 | RT1000 Tapping Tool | 6.8 | V Head Pipe Stands | 2.4 |
| No. KOPD-254 | 11.8 | RT3422 Tapping Tool | 6.9 | Vacuum Accessories | 14.16 |
| No. KOPD-52 | 11.8 | S | | Vacuum Outlet Pump | 14.21 |
| O | | Saw Blades | 7.6 | Vacuums | 14.1 |
| Offset Pipe Wrenches | 1.5 | Saws | 7.6 | Vacuums, 2-Stage Industrial | 14.14 |
| Oiler | 4.12 | SC-60C Scissor Cutter Head | 11.4 | Vacuums, Motor-On-Bottom | 14.12 |
| One Stop Wrench | 1.1 | Screw Extractors | 7.11 | Vacuums, Specially | 14.7 |
| One-Piece Flat Sewer Tape | 13.7 | Screw Feed Tubing Cutters | 3.17 | Vacuums, Standard | 14.2 |
| Open Bale Drum Machines | 13.24 | Screwdrivers | 7.8 | Variable Pitch Hole Saws | 6.5 |
| Optional Die Heads | 4.25 | Sectional Machines | 13.26 | Vises | 2.2 |
| P | | SeekTech Inductive Signal Clamp | 12.36 | W | |
| Pex Crimp Tools | 10.13 | SeekTech SR-20 Locator | 12.32 | Water Jetting Machines | 13.38 |
| PEX-One Battery Crimp Tool | 10.13 | SeekTech SR-60 Locator | 12.34 | Wet Application Filter | 14.18 |
| Pipe Beveling | 3.23 | SeekTech ST-305 Line Transmitter | 12.36 | Wide-Roll Pipe Cutter | 3.3 |
| Pipe Cutters | 3.2 | SeekTech ST-510 Line Transmitter | 12.36 | Wrench Parts | 1.1 |
| Pipe Extractors | 3.8 | SeeSnake® Compact2 Camera System | 12.9 | Wrenches | 1.1 |
| Pipe Freezers | 9.4 | SeeSnake® CS10 Digital Recording Monitor | 12.15 | X | |
| Pipe Reamers / Extractors / Taps | 3.8 | SeeSnake® CS6 and CS6Pak Digital Recording Monitors | 12.16 | XF45 and XF50 Quick Acting Vises | 7.3 |
| Pipe Stands | 2.4 | SeeSnake® Digital Laptop Interface | 12.19 | | |
| Pipe Taps: Hand Use Only | 3.8 | SeeSnake® DVD Pak2 Inspection Camera Monitor | 12.14 | | |
| Pipe Thawers | 9.5 | SeeSnake® HQ Digital Inspection Software | 12.20 | | |
| Pipe Vises | 2.2 | SeeSnake® MAX rM200 Series | 12.8 | | |
| Pipe Vises & Supports | 2.1 | SeeSnake® microDrain™ Video Inspection System | 12.1 | | |
| Pipe Welding Vises | 2.3 | SeeSnake® microReel Video Inspection System | 12.11 | | |
| Pipe/Tube Cutting & Preparation | 3.1 | SeeSnake® Mini Video Inspection System | 12.6 | | |
| Plastic Pipe Cutters | 3.19 | SeeSnake® nanoReel Industrial Video Inspection System | 12.12 | | |
| Pliers | 7.9 | SeeSnake® Self-Leveling Camera | 12.7 | | |
| Plumbing Locating | 12.36 | SeeSnake® Standard Camera | 12.7 | | |
| Portable Chain and Yoke Vises | 2.3 | SeeSnakeHQ™ Digital Inspection Software | 12.2 | | |
| Portable TRISTAND® Vises | 2.2 | Semi-Trash Pumps | 13.46 | | |
| Power Drives | 4.13 | Sewer Tape | 13.7 | | |
| Power Pipe Cutting | 3.9 | SF-2500 Superfreeze | 9.4 | | |
| Power Spin with AUTOFEED® | 13.8 | Showels | 7.1 | | |
| Power-Driven 916 Roll Groover | 5.5 | Single Stroke Cutters | 3.19 | | |
| Precision Non-Ratcheting Flare Tools | 8.6 | Sink Machines | 13.9 | | |
| Precision Ratcheting Flare Tools | 8.7 | Sizing Tools | 3.21 | | |
| Press Jaws | 10.7 | Snips | 7.9 | | |
| Press Rings | 10.9 | Soil Pipe Cutters | 3.4 | | |
| Press Snap™ Soil Pipe Cutter | 10.13 | Soldering Guns | 9.3 | | |
| Press Tools | 10.1 | Specific Purpose Wrenches | 1.8 | | |
| Pressing | 10.1 | Spring-Type Tube Benders | 8.4 | | |
| PressSnap Soil Pipe Cutter | 10.14 | Spud Wrenches | 1.6 | | |
| Pressure Test Pumps | 9.2 | SR-24 Line Locator with Bluetooth® and GPS | 12.33 | | |
| Professional Portable Air Mover | 14.21 | ST-33Q+ Line Transmitter with Bluetooth® | 12.35 | | |
| PTEC Plastic Drain Pipe Cutter | 3.2 | Stainless Steel Tubing Cutters | 3.17 | | |
| Pump Accessories | 13.46 | Stand Chain Vise | 2.2 | | |
| Pumps | 13.44 | Standard Series Jaws | 10.8 | | |
| Q | | Standard Series Jaws for ProPress® System | 10.8 | | |
| Quick Connect Pump | 14.21 | Standard Series Jaws for PureFlow™ System | 10.9 | | |
| Quick-Acting Tubing Cutters | 3.16 | Standard Series ProPress® XL-C™ Rings | 10.9 | | |
| R | | Straight Pipe Wrenches | 1.2 | | |
| RapidGrip® Wrenches | 1.3 | Strap Wrenches | 1.7 | | |
| Raprench® Wrenches | 1.4 | STRAPLOCK Pipe Handle | 7.13 | | |
| Ratchet & Handle Only | 4.3 | Swaging Tools | 8.6 | | |
| Ratchet Benders | 8.4 | Swiv-L-Punch™ Knockout Punch Head | 11.6 | | |
| Ratchet Cable Cutters | 11.1 | T | | | |
| Ratchet Cutters with Ergonomic Grips | 3.19 | Tape Measures | 7.8 | | |
| RE 12-M Manual Hydraulic Crimp Tool | 11.9 | Tapping Tools | 6.8 | | |
| RE 6 Electrical Tool | 11.3 | Telescoping Basin Wrench | 1.8 | | |
| Reamers, Deburring Tools | 3.22 | Test and Measurement | 12.1 | | |
| Reamers, Extractors & Taps | 3.8 | Thin-Wall Conduit Benders | 11.12 | | |
| Receding Geared Threaders | 4.1 | Thread Cutting Oil | 4.12 | | |
| Reciprocating Saw Blades | 6.6 | Thread Sealant | 4.11 | | |
| Reels & Cameras | 12.1 | Threader Stands | 4.24 | | |
| Remote Transmitter (512 Hz Sonde) | 12.4 | Threading | 4.1 | | |
| Replacement Cutting Wheels | 3.18 | Threading Accessories | 4.11 | | |
| Replacement Drill Guides | 7.12 | Threading Machines | 4.17 | | |
| RIDGID Hammers | 7.5 | Three-Way Pipe Threaders | 4.4 | | |
| RIDGID Hydraulic Benders - Formers and Accessories | 8.9 | Toilet/Urinal Augers | 13.6 | | |
| RIDGID Thread Sealants | 4.11 | Tool Boxes | 7.7 | | |
| RIDGID® CrossChek™ Inspection System | 12.13 | Torque Wrenches | 3.6 | | |
| RIDGIDConnect™ Online Business Tool | 12.21 | Tube Benders | 8.4 | | |
| Rings for ProPress® | 10.1 | Tube Expanders | 8.5 | | |

Model

| | | | | | | | | | | | |
|-------------------------|------------|-------------|------------|-----------------|------------|---------|------------|----------|------------|------------|--------------|
| #4 | 4.12 | 65R-TC | 4.8 | 266 | 3.7 | 472-CI | 3.3 | 811A | 4.16, 4.19 | 1619 | 7.7 |
| 1 | 1.7, 7.11 | 65S | 3.17, 3.18 | 276 | 3.4, 3.6 | 472-HWS | 3.3 | | 4.22, 4.23 | 1619F | 7.7 |
| | 7.12 | 72 | 3.22 | | 3.7 | 472-S | 3.3 | | 4.25, 4.28 | 1620 | 7.7 |
| 1A | 3.7 | 73 | 3.22 | 300 | 4.16 | 472C | 3.7 | | 4.29 | 1620RV | 14.11 |
| 2 | 1.7, 3.8 | 74 | 3.22 | 300 Compact | 4.23 | 472HWS | 3.7 | 812 | 1.2 | 1621 | 7.12 |
| | 7.11, 7.12 | 87 | 11.11 | 300 Compact Kit | 4.23 | 472S | 3.7 | 814 | 1.2 | 1650RV | 14.13 |
| 2-A | 3.2 | 92 | 2.5 | 300 Complete | 4.17 | 500 UM | 7.4 | 815A | 4.16, 4.19 | 1721 | 7.12 |
| 2-S | 3.8 | 100A | 4.19, 4.21 | 301A | 3.12, 3.13 | 500A | 4.25, 4.28 | | 4.23, 4.25 | 1821 | 7.12 |
| 2A | 3.7 | | 4.23, 4.24 | 303 | 7.5 | 500B | 4.29, 4.30 | | 4.28, 4.29 | 1974 | 7.8 |
| 2P | 1.7 | | 4.27 | 310M | 8.2 | 504A | 4.28, 4.29 | 816 | 4.19, 4.21 | 2002 | 1.1 |
| 3 | 3.8, 7.11 | 100B | 10.2 | 310/316M | 8.2 | 514 | 4.28 | | 4.22, 4.23 | 2006 | 1.9 |
| | 7.12 | 101 | 3.14, 3.18 | 311 | 4.16 | 515 | 4.28 | | 4.25, 4.28 | 2017 | 1.8 |
| 3-S | 3.2 | 103 | 3.14, 3.18 | 312 | 4.16, 8.2 | 531 | 4.19, 4.22 | | 4.29 | 2191 | 3.12, 3.13 |
| 3S | 3.7 | 104 | 3.14, 3.18 | 312M | 8.2 | | 4.23, 4.25 | 817 | 4.19, 4.21 | 3215 | 1.7 |
| 4 | 7.11, 7.12 | 106 | 3.17, 3.18 | 314M | 8.2 | | 4.30 | | 4.22, 4.23 | 3229 | 1.7 |
| 4-S | 3.2 | 108 | 3.17, 3.18 | 315M | 8.2 | 532 | 4.19, 4.23 | | 4.25, 4.28 | 3231 | 1.7 |
| 4S | 3.7 | 109 | 3.17, 3.18 | 318M | 8.2 | | 4.25, 4.29 | | 4.29 | 3233 | 1.7 |
| 4U | 4.19, 4.25 | 109-P | 3.17 | 320-E | 10.2 | | 4.30 | 818 | 1.2 | 3235 | 1.7 |
| 5 | 1.7, 7.3 | 109P | 3.18 | 341 | 4.16, 4.19 | 535 | 4.21 | 819 | 4.16, 4.19 | 3237 | 1.7 |
| | 7.11, 7.12 | 111-R | 4.3 | | 4.21 | 535A | 4.10, 4.19 | | 4.21, 4.23 | 4000RV | 14.2 |
| 5P | 1.7 | 116 | 7.5 | 342 | 1.9 | 541 | 4.27, 4.30 | | 4.27, 4.31 | 4100 | 3.21 |
| 6 | 1.2, 7.11 | 117 | 3.14, 3.18 | 344 | 4.22 | 542 | 4.27, 4.29 | 820 | 3.7, 4.19 | 4500RV | 14.7 |
| | 7.12 | 118 | 3.14, 3.15 | 345 | 8.7 | | 4.30 | | 4.21 | 6000RV | 14.3 |
| 6-S | 3.2 | | 3.18 | 345-DL | 8.7 | 555 | 4.28 | 824 | 1.2 | 405/408M | 8.2 |
| 6S | 3.7 | 120 | 7.5 | 345/150 | 8.7 | 560 | 2.2 | 836 | 1.2 | 605/608M | 8.3 |
| 6U | 4.19, 4.25 | 122 | 3.12, 3.18 | 345/150DL | 8.7 | 562 | 8.6 | 839 | 4.19, 4.31 | 832068 | 14.16 |
| 7 | 7.11, 7.12 | 122SS | 3.12, 3.13 | 346 | 4.10 | 563 | 8.6 | 840A | 4.10, 4.27 | 832069 | 14.16 |
| | 8.5 | | 3.18 | 358 | 8.4 | 564 | 8.6 | 842 | 4.19, 4.25 | 832077 | 14.16 |
| 8 | 1.2, 7.11 | 122XL | 3.13, 3.18 | 360 | 3.7, 4.16 | 565 | 8.6 | | 4.28 | 832078 | 14.16 |
| | 7.12, 8.5 | 127 | 3.22 | 364 | 3.7 | 570 | 8.6 | 844 | 4.10, 4.21 | 832079 | 14.16 |
| 8R111S | 11.7 | 127S | 3.22 | 368 | 8.4 | 575 | 3.21 | 848 | 1.2 | 832080 | 14.16 |
| 9 | 7.3 | 141 | 4.1 | 375 | 8.8 | 600-I | 4.13 | 856 | 4.19, 4.25 | Auto-Clean | 13.9 |
| 10 | 1.2, 1.3 | 150 | 3.15, 3.18 | 377 | 8.6 | 603 | 8.3 | | 4.28 | A-1 | 13.27, 13.29 |
| | 1.4, 3.17 | 150-L | 3.15 | 378 | 8.4 | 604 | 8.3 | 880 | 3.8 | | 13.31, 13.33 |
| | 3.18, 7.11 | 150-LS | 3.15 | 395 | 7.4 | 606 | 7.7, 8.3 | 881 | 3.8 | | 13.35, 13.37 |
| 10 GALLON ProPack® Plus | | 150A | 4.19, 4.21 | 402 | 4.12 | 606M | 8.3 | 882 | 3.8 | A-1HD | 13.31, 13.33 |
| WET/DRY VAC | 14.8 | | 4.23, 4.24 | 403 | 8.2 | 608 | 8.3 | 883 | 3.8 | A-2 | 13.27, 13.29 |
| 11-R | 4.3, 4.5 | 151 | 4.27 | 404 | 8.2 | 610M | 8.3 | 902 | 3.6 | | 13.31, 13.33 |
| | 4.6, 4.7 | 151 CSST | 3.16, 3.17 | 406 | 8.2 | 612M | 8.3 | 904 | 3.6 | | 13.35, 13.37 |
| 12 | 1.2, 7.3 | 151-ML | 3.16 | 406M | 8.2 | 614 | 3.11 | 911 | 4.27, 4.28 | A-2HD | 13.31, 13.33 |
| | 7.5 | 151-P | 3.16, 3.18 | 408 | 8.2 | 616 | 7.8 | | 4.29, 5.6 | A-3 | 13.21, 13.23 |
| 12-R | 4.3, 4.5 | 152 | 3.16, 3.18 | 410M | 8.2 | 625 | 7.8 | 912 | 5.6 | | 13.25, 13.29 |
| | 4.6, 4.7 | 152-P | 3.16, 3.18 | 412M | 8.2 | 640 | 2.3 | 913 | 4.27, 4.28 | | 13.31, 13.33 |
| 14 | 1.2, 1.3 | 153 | 3.16, 3.18 | 415 | 4.29 | 690-I | 4.14 | 914 | 4.27, 5.6 | | 13.35, 13.37 |
| | 1.5 | 153-P | 3.16, 3.18 | 418 | 4.12, 4.13 | 700 | 3.9, 4.15 | 915 | 5.3, 5.6 | A-4 | 13.31, 13.33 |
| 15 | 3.17, 3.18 | 154 | 3.16, 3.18 | | 4.14, 4.15 | 707 | 7.9 | 916 | 5.5 | | 13.35 |
| 15-SI | 3.17, 3.18 | 154-P | 3.16, 3.18 | 419 | 4.16 | 709 | 7.9 | 918 only | 5.6 | A-5 | 13.29 |
| 16 | 7.5 | 156 | 3.16, 3.18 | 424 | 4.27 | 711 | 4.27, 4.28 | 918-I | 5.7 | A-8 | 13.29, 13.31 |
| 17 | 1.5 | 156-P | 3.16, 3.18 | 424-CI | 4.29 | | 4.29 | 918-1 | 5.6 | | 13.33, 13.35 |
| 18 | 1.2, 1.3 | 161 | 4.1 | 424-S | 3.3 | 713 | 4.27, 4.28 | 918-2 | 5.6 | A-9 | 13.31, 13.33 |
| | 1.5 | 170 | 7.1 | 424S | 3.7 | | 7.9 | 918-4 | 5.6 | | 13.35 |
| 20 | 3.17, 3.18 | 170FG | 7.1 | 425 | 2.2, 4.13 | 714 | 4.27 | 918-5 | 5.6 | A-10 | 13.27, 13.29 |
| 21 | 2.3 | 171FG | 7.1 | 445R | 8.7 | 716 | 7.9 | 920 | 5.8 | A-12 | 13.17, 13.29 |
| 23 | 2.3 | 171FG | 7.1 | 454-W | 8.8 | 724 | 7.4 | 921 | 7.12 | | 13.31, 13.33 |
| 24 | 1.2, 1.5 | 200A | 4.19, 4.21 | 455 | 8.8 | 725 | 4.27 | 965 | 2.5 | | 13.35, 13.37 |
| | 7.5 | | 4.23, 4.24 | 456 | 8.3 | 732 | 3.7, 4.22 | 975 | 5.4 | A-13 | 13.11, 13.15 |
| 25 | 1.5, 2.3 | 202 | 3.3, 3.7 | 456R | 8.7 | 734 | 7.9 | 1000RV | 14.8 | | 13.17, 13.27 |
| | 7.12 | 205 | 3.16, 3.18 | 458 | 8.6 | 744 | 4.27 | 1017 | 1.8 | | 13.29 |
| 27 | 2.3 | 205S | 3.16 | 458MM | 8.6 | 756 | 1.7 | 1019 | 1.8 | A-14-6 | 13.27 |
| 30 | 3.17, 3.18 | 206 | 3.4, 3.7 | 458R | 8.7 | 758 | 1.7, 4.10 | 1021 | 7.12 | A-14-10 | 13.27 |
| 31-A BSPT | 4.4 | 206 | 3.4, 3.7 | 460-6 | 2.2, 4.13 | 760 | 1.7 | 1121 | 7.12 | A-17 | 13.31, 13.33 |
| 31-A NPSM | 4.4 | 206/226/276 | 3.4, 3.6 | 460-12 | 2.2 | 762 | 1.7 | 1200RV | 14.4 | | 13.35 |
| 31-A NPT | 4.4 | 212 | 7.6 | 462 | 2.3 | 764 | 3.7, 4.27 | 1203 | 4.22 | A-17-A | 13.27 |
| 31B | 4.7 | 216 | 7.5 | 463 | 2.3 | 765 | 1.7 | 1206 | 4.16 | A-17-B | 13.27 |
| 32 | 4.16, 5.8 | 220 | 7.5 | 464 | 2.3 | 766 | 4.27 | 1215 | 4.22 | A-17-C | 13.27 |
| | 7.5 | 223S | 3.22 | 466-CI | 3.3 | 768 | 1.7, 4.10 | 1218-BM | 7.6 | A-17-D | 13.27 |
| 33B | 4.7 | 226 | 3.4, 3.7 | 466-D | 3.3 | | 4.21 | 1219 | 4.22, 4.31 | A-17-E | 13.27 |
| 35B | 4.7 | 227S | 3.22 | 466-HWS | 3.3 | 770 | 4.15 | 1221 | 7.12 | A-18 | 13.27 |
| 35S | 3.17, 3.18 | 228 | 3.6 | 466-S | 3.3 | 771 | 4.15 | 1224 | 4.26 | A-20 | 13.31, 13.33 |
| 36 | 1.2, 7.12 | 238-P | 3.4, 3.5 | 466S | 3.7 | 772 | 4.15 | 1224-BM | 7.6 | | 13.35 |
| | 7.11 | 246 | 3.4, 3.5 | 466S | 3.7 | 773 | 4.15 | 1248 | 6.4 | A-25 | 13.29 |
| 37B | 4.7 | 250 | 4.23, 4.24 | 466S | 3.7 | 774 | 1.7, 4.15 | 1249 | 6.4 | A-30TW | 13.27 |
| 39 | 2.3 | 254 | 3.8 | 468-CI | 3.3 | 775 | 4.15 | 1250 | 6.4 | A-30 | 13.27, 13.29 |
| 40-A | 2.2 | 254 | 3.8 | 468-HWS | 3.3 | 786 | 7.9 | 1321 | 7.12 | A-34-10 | 13.31, 13.33 |
| 42-A | 3.3 | 258 | 3.9 | 468-S | 3.3 | 787 | 7.9 | 1400RV | 14.5 | | 13.35 |
| 42A | 3.7 | 258-XL | 3.1 | 468C | 3.7 | 788 | 7.9 | 1406 | 4.24 | A-34-12 | 13.31, 13.33 |
| 44-S | 3.3 | 258FP | 3.1 | 468HWS | 3.7 | 796 | 7.9 | 1421 | 7.12 | | 13.35 |
| 44S | 3.7 | 258PS | 3.9, 3.10 | 468S | 3.7 | 797 | 7.9 | 1450 | 9.2 | A-34-16 | 13.31, 13.33 |
| 46 | 2.5, 4.10 | | | | | 800 LMI | 7.4 | 1452 | 4.16 | | 13.35 |
| 46 | 11.4 | | | | | 810 | 1.2 | 1521 | 7.12 | A-35 | 13.29 |
| 4P-6 | 1.2 | | | | | | | 1602 | 7.7 | A-35TW | 13.29 |
| 48 | 1.2 | | | | | | | 1610RV | 14.6 | A-36 | 13.29 |
| 60 | 1.2 | | | | | | | | | | |
| 65R-C | 4.8 | | | | | | | | | | |

MODEL NUMBER INDEX

Model

| | | | | | |
|-------------------------------|--------------------------------|----------------------|--------------------------|------------------------------|---------------------------------|
| A-39AF.....13.11, 13.13 | CS6.....12.16 | D-987.....6.6 | E-4695.....11.11 | H-111.....13.43 | K-1500SPA.....13.32 |
| A-40.....13.27 | C-7.....13.27, 13.28 | D-988.....6.6 | E-5112.....3.8 | H-112.....13.43 | K-1500SPB.....13.32 |
| A-40AF.....13.11 |13.29 | D-989.....6.6 | E-5113.....3.8 | H-115.....13.43 | KJ-1750.....13.39 |
| A-40B.....13.11 | C-8.....13.27, 13.29 | D-990.....6.6 | E-5114.....3.8 | HKO-186.....11.7 | KJ-1750-C.....13.39 |
| A-40G.....13.11 | C-9.....13.15, 13.27 | D-992.....6.6 | E-5115.....3.8 | HC300.....6.2 | KJ-2200.....13.4 |
| A-60-12.....13.29 |13.28, 13.29 | D-993.....6.6 | E-5116.....3.8 | HC300-J.....6.2 | KJ-2200-C.....13.4 |
| A-60-16.....13.29 | C-10.....13.29, 13.31 | D-994.....6.6 | E-5117.....3.8 | HB382.....8.8 | KJ-3100.....13.42 |
| A-61.....13.29, 13.31 |13.33, 13.35 | D-1375.....8.4 | E-5118.....3.8 | HB383.....8.8 | K-3800.....13.16 |
|13.33 | C-10 PC.....13.29, 13.31 | D-1376.....8.4 | E-5119.....3.8 | HC450.....6.3 | K-6200.....13.18, 13.19 |
| A-62.....13.29, 13.31 |13.33, 13.35 | D-1377.....8.4 | E-5120.....3.8 | HF0500.....14.19 | K-7500.....13.22 |
|13.33 | C-11.....13.31, 13.33 | D-1378.....8.4 | E-5272.....3.18 | HF1000.....14.19 | KJ-1350-2.....13.38 |
| A-75.....13.21, 13.25 |13.35 | D-1379.....8.4 | E-5299.....3.18 | H-1211.....13.38, 13.39 | KJ-1350-2C.....13.38 |
| A-75DR.....13.23 | C-11 PC.....13.31, 13.33 | D-1380.....8.4 | E-5732.....8.4 |13.41 | K-400 with C-31 IW.....13.14 |
| A-75PF.....13.21, 13.23 | C-12.....1.6, 13.31 | D-1381.....8.4 | E-5734.....8.4 | H-1215.....13.38, 13.39 | K-400 AF with C-32 IW.....13.14 |
|13.25 |13.33, 13.35 | D-1382.....8.4 | E-10279.....3.18 |13.41 | K-400 with C-32 IW.....13.14 |
| AR99.....2.5 | C-13IC.....13.11, 13.13, 13.17 | D-1440.....4.1 | FV-1.....13.41, 13.43 | H-1220.....13.38, 13.39 | K-400 with C-44 IW.....13.14 |
| A-368X.....13.31, 13.33 | C-13ICSB.....13.11 | E-6.....1.4 | F-3.....3.7 |13.41 | K-400 AF with C-45 IW.....13.14 |
| A-369X.....13.31, 13.33 | C-14.....1.6, 13.31 | E-8.....1.4 | F-3S.....3.7 | H-1235.....13.38, 13.39 | K-400 with C-45 IW.....13.14 |
|13.35 |13.33, 13.35 | E-10.....1.4 | F-10.....7.4 |13.41 | K-400 with C-45 IW.....13.14 |
| A-380.....13.17 | C-15.....13.31, 13.33 | E-12.....1.4 | F-45.....7.2 | H-1250.....13.38, 13.39 | K-40 AF 110 V.....13.1 |
| A-381.....13.17 |13.35 | E-14.....1.4 | F-50.....7.2 |13.41 | K-1500G with C-14.....13.34 |
| A-381-A.....13.17 | C-18.....1.6 | E-18.....1.4 | F-60.....7.2 | H-1400.....13.38, 13.39 | K-3800 with C-31.....13.16 |
| A-2474.....13.37 | C-21.....13.11, 13.13, 13.27 | E-24.....1.4 | F-119.....3.7 |13.41, 13.43 | K-3800 with C-32.....13.16 |
| A-2475.....13.37 | C-22.....13.11, 13.13, 13.27 | E-36.....1.4 | FC-150.....3.21 | H-1415.....13.38, 13.39 | K-3800 with C-45.....13.16 |
| A-2476.....13.37 | C-23IC.....13.11, 13.13 | E-37.....8.8 | F-158.....3.18 |13.41, 13.43 | K-3800 with C-46.....13.16 |
| AM2560.....14.21 |13.17 | E-45.....8.8 | FC-200.....3.21 | H-1435.....13.38, 13.39 | K-6200 with C-24.....13.18 |
| A-2704.....13.37 | C-24.....1.6, 13.19 | E-46.....8.8 | F-229.....3.7 |13.41, 13.43 | K-6200 with C-24 HD Cable ... |
| A-3179.....13.27 |13.21, 13.23 | E-47.....8.8 | F-229S.....3.7 | H-1450.....13.38, 13.39 |13.18 |
| A3800 PF.....13.17 |13.25 | E-52.....8.8 | F-366.....3.7 |13.41, 13.43 | K-7500 w/C-75.....13.22 |
| A-6582.....13.21, 13.23 | C-24 HD.....13.19 | E-61.....8.8 | F-367.....3.7 | H-1475.....13.38, 13.39 | K-7500 C-100.....13.22 |
|13.25 | C-24HC.....13.19, 13.21 | E-63.....8.8 | F-367-S.....3.7 |13.41, 13.43 | K-750 with C-24.....13.2 |
| A-6583.....13.21, 13.23 |13.23, 13.25 | E-64.....8.8 | F-383.....3.7 | HKO-1810.....11.7 | K-750 with C-27.....13.20 |
|13.25 | C-25.....13.19, 13.21 | E-109.....3.7 | F-514.....3.7 | H-1825.....13.38, 13.39 | K-750 with C-75.....13.2 |
| A-7534.....13.21, 13.25 |13.23, 13.25 | E-110.....1.5 | F-515.....3.7 | H-1850.....13.38, 13.39 | MaxCore Cable.....13.8, 13.9 |
| A-7534D.....13.23 | C-25 HD.....13.19 | E-258.....3.9, 3.10 | F-546.....3.7 | H-3810.....13.43 | MJ-1.....4.21 |
| A-7558.....13.21, 13.25 | C-26.....13.19, 13.21 | E258-T.....3.9, 3.10 | F-50 & F-60.....7.2 | H-3815.....13.43 | M14.....6.5 |
| A-7558D.....13.23 | C-26.....13.23, 13.25 | E-635.....3.18 | HW-EL.....13.38, 13.39 | H-3820.....13.38, 13.43 | M16.....6.5, 6.8 |
| A-7570.....13.21, 13.23 | C-26 HD.....13.19 | E635.....3.17 | HL-1.....13.38, 13.39 | H-3830.....13.43 |6.9 |
|13.25 | C-27.....13.19, 13.21 | E-702.....3.18 |13.41, 13.43 | H-3850.....13.43 | M17.....6.5 |
| A-7571.....13.21, 13.23 | C-27 HD.....13.19 | E-729.....4.31 | HL-2.....13.38, 13.39 | Kwik-Spin.....13.9 | M19.....6.5 |
|13.25 | C-27HC.....13.19, 13.21 | E-730.....4.31 |13.41, 13.43 | K-3.....13.6 | M20.....6.5 |
| BC2A.....2.2 | C-27HC.....13.19, 13.21 | E-731.....4.31 | HF-4.....13.41, 13.43 | K-5.....13.7 | M21.....6.5 |
| BC4A.....2.2 |13.23, 13.25 | E-732.....4.31 | H-5.....13.38, 13.39 | K-6.....13.6 | M22.....6.5, 6.8 |
| BTH-9.....2.4 | C-28.....13.21, 13.23 | E-733.....4.31 |13.41, 13.43 | K-6 DH.....13.6 |6.9 |
| B-171-X.....4.15 |13.25 | E-734.....4.31 | H-10.....13.38, 13.39 | K-10.....13.37 | M24.....6.5 |
| BC210.....2.2 | C-29.....13.21, 13.23 | E-735.....4.31 | H-10 WH.....13.38, 13.39 | K-25-BP.....13.8 | M25.....6.5 |
| BC210P.....2.2 |13.25 | E-736.....4.31 | H-18.....11.7 | K-25-DH.....13.8 | M27.....6.5 |
| BC410.....2.2 | C-31.....13.17 | E-863.....4.16 | H-21.....13.38, 13.39 | K-26.....13.8 | M29.....6.5, 6.9 |
| BC410P.....2.2 | C-31IW.....13.15, 13.17 | E-910.....1.4 |13.41, 13.43 | K-30.....13.9 | M30.....6.5 |
| BC510.....2.2 | C-32.....13.17 | E-914.....1.4 | H-22.....13.38 | K-40.....13.1 | M32.....6.5 |
| BC610.....2.2 | C-32IW.....13.15, 13.17 | E-918.....1.4 | HP-22.....13.41 | K-40AF.....13.1 | M33.....6.5 |
| BC810.....2.2 | C-33.....13.17 | E-924.....1.4 | HW-22.....13.41 | K-40B AF.....13.1 | M35.....6.5, 6.9 |
| B-1677.....11.12 | C-33IW.....13.15, 13.17 | E-1032.....3.7 | H-24.....13.38 | K-45.....13.12 | M37.....6.5 |
| B-1678.....11.12 | C-36.....1.6 | E-1032S.....3.7 | H-25.....13.38, 13.39 | K-45AF.....13.12 | M38.....6.5 |
| B-1679.....11.12 | C-44.....13.17 | E-1240.....3.18 |13.41, 13.43 | K-50.....13.26 | M40.....6.5 |
| B-1709.....11.12 | C-44IW.....13.15, 13.17 | E-1525.....3.18 | H-30.....13.38, 13.39 | K-60SP.....13.28 | M41.....6.5 |
| B-1711.....11.12 | C-45.....13.17 | E-1740.....3.18 |13.41 | K-60SP-SE.....13.28 | M43.....6.5 |
| B-1712.....11.12 | C-45HC.....13.17 | E-1962.....3.7 | H-30 WH.....13.39, 13.41 | KT-190.....9.5 | M44.....6.5, 6.9 |
| B-3542.....13.37 | C-45IW.....13.15, 13.17 | E-2155.....3.18 | H-30A.....13.38 | KT-200.....9.5 | M46.....6.5 |
| B-6840.....13.21, 13.23 | C-46.....13.17 | E-2156.....3.18 | HW-30.....13.43 | K-45-1.....13.12 | M48.....6.5 |
|13.25 | CS65.....12.17, 12.18 | E-2157.....3.18 | H-31.....13.38 | K-45AF-1.....13.12 | M51.....6.5 |
| B-6841.....13.21, 13.23 | C-75.....13.21, 13.23 | E-2191.....3.18 | H-32.....13.38, 13.39 | K-45-5.....13.12 | M52.....6.5 |
|13.25 |13.25 | E-2267.....3.7 |13.41, 13.43 | K-45AF-5.....13.12 | M54.....6.5 |
| Cable.....13.8 | C-75HC.....13.21, 13.23 | E-2558.....3.18 | H-38.....13.43 | K-45-7.....13.12 | M57.....6.5 |
| Certified HEPA Filter and |13.25 | E-2632.....3.7 | H-38 WH.....13.43 | K-45AF-7.....13.12 | M59.....6.5 |
| Pre-Filter.....14.19 | CJ-99.....2.4 | E-2724.....13.7 | H-41.....13.39 | K-50-4.....13.26 | M60.....6.5 |
| CSST.....3.18 | C-100.....13.21, 13.23 | E-2725.....13.7 | H-42.....13.39 | K-50-6.....13.26 | M64.....6.5 |
| C-1.....13.11, 13.13, 13.27 |13.25 | E-2726.....13.7 | H-44.....13.39 | K-50-8.....13.26 | M65.....6.5 |
| C-1IC.....13.11, 13.13 | C-100HC.....13.21, 13.23 | E-2727.....13.7 | H-45.....13.39 | K-50-9.....13.26 | M67.....6.5 |
|13.17, 13.27 |13.25 | E-2729.....13.7 | H-51.....13.39 | K-750.....13.20 | M70.....6.5 |
| C1.....10.10 | CD-100 RS.....12.29 | E-2731.....13.7 | H-52.....13.39 | K-750R.....13.24 | M73.....6.5 |
| C-2.....13.11, 13.13 | CT400.....10.2 | E-2737.....13.7 | H-61.....13.41 | K-1000.....13.36 | M76.....6.5 |
|13.27 | C-6429.....13.13 | E-2739.....13.7 | H-62.....13.41 | KJ-1350.....13.38 | M79.....6.5 |
| C-2IC.....13.11, 13.13 | D-380-X.....4.31 | E-2741.....13.7 | H-64.....13.41 | KJ-1350-C.....13.38 | M83.....6.5 |
|13.17, 13.27 | D-969.....6.4 | E-2743.....13.7 | H-65.....13.41 | K-1500A.....13.3 | M86.....6.5 |
| C-4.....13.11, 13.13 | D-980.....6.6 | E-2880.....3.18 | H-71.....13.41 | K-1500A Only.....13.30 | M89.....6.5 |
|13.27 | D-981.....6.6 | E-2990.....3.18 | H-72.....13.41 | K-1500B.....13.3 | M92.....6.5 |
| C-5.....13.11, 13.13 | D-984.....6.6 | E-3186.....3.7 | H-75.....13.41 | K-1500B Special Kit.....13.3 | M95.....6.5 |
|13.27 | D-985.....6.6 | E-3469.....3.18 | H-101.....13.43 | K-1500G.....13.34 | M98.....6.5 |
| C-6.....13.11, 13.13 | DP-985.....6.6 | E-3495.....3.18 | H-102.....13.43 | K-1500SP.....13.32 | micro CD-100.....12.29 |
|13.27 | D-986.....6.6 | E-4266.....3.7 | H-104.....13.43 | K-1500SP-A.....13.32 | micro LM-100.....12.27 |
| C-6IC.....13.11, 13.13, 13.27 | DDP-986.....6.6 | E-4546.....3.18 | H-105.....13.43 | K-1500SP-B.....13.32 | M102.....6.5 |

Model

| | | | | |
|-------------------------|-------------------------|-------------------------|------------------------|---------------------|
| M105.....6.5 | T-2.....13.31, 13.33 | T-50-2.....13.31, 13.33 | T-231.....13.11, 13.13 | VT 2508.....14.16 |
| M108.....6.5 | 13.35, 13.37 | 13.35 | 13.17, 13.27 | VT 2509.....14.16 |
| M110.....6.5 | TP2HK.....13.46 | T-50-3.....13.31, 13.33 | T-232.....13.11, 13.13 | VT 2510.....14.16 |
| M114.....6.5 | T-3.....13.31, 13.33 | 13.35 | 13.17, 13.27 | VT 2514.....14.16 |
| M121.....6.5 | 13.35 | T-101.....13.17, 13.29 | T-240.....13.17, 13.27 | VT 2520.....14.16 |
| M127.....6.5 | TP3HK.....13.46 | T-102.....13.17, 13.29 | T-250.....13.11, 13.13 | VT 2525.....14.16 |
| M140.....6.5 | T-4.....13.31, 13.33 | T-103.....13.29 | 13.27 | VT 2530.....14.16 |
| M152.....6.5 | 13.35, 13.37 | T-104.....13.17, 13.29 | TP-250.....13.44 | VT 2540.....14.16 |
| Model 1250RV.....14.12 | T-5.....13.31, 13.33 | T-105.....13.17, 13.29 | T-260.....13.15, 13.17 | VT 2561.....14.16 |
| O-R.....4.7 | 13.35 | T-106.....13.17, 13.29 | T-270.....13.17 | VT 2570.....14.16 |
| OO-R.....4.5, 4.7 | T-6.....13.31, 13.33 | T-107.....13.17, 13.29 | T-300.....13.37 | VT 2571.....14.16 |
| OO-RB.....4.5, 4.7 | 13.35 | T-109.....13.29 | T-301.....13.37 | VT 2575.....14.16 |
| Power Spin.....13.8 | T-7.....13.31, 13.33 | T-110.....13.29 | T-302.....13.37 | VT2580.....14.1 |
| PH-60C.....11.6 | 13.35, 13.37 | T-111.....13.29 | T-303.....13.37 | VF3500RT.....14.17 |
| PC-1250.....3.19 | T-8.....13.31, 13.33 | T-112.....13.17, 13.29 | T-304.....13.37 | VF3501.....14.2 |
| PCB-1250.....3.19 | 13.35 | T-113.....13.17, 13.29 | T-306.....13.37 | VF3502.....14.2 |
| PC-1375 ML.....3.19 | T-9.....13.31, 13.33 | T-114.....13.17, 13.29 | T-307.....13.37 | VF3503.....14.2 |
| PCB-1375.....3.19 | 13.35 | T-121.....13.17 | T-310.....13.37 | VF3800.....14.1 |
| PTEC 3000.....3.2 | T-10.....13.31, 13.33 | T-122.....13.17 | T-312.....13.37 | VF4000.....14.17 |
| PTEC 5000.....3.2 | 13.35 | T-125.....13.17, 13.29 | T-313.....13.37 | VF5000.....14.17 |
| R-0.....13.37 | T-11.....13.31, 13.33 | T-127.....13.29 | T-316.....13.37 | VF6000.....14.18 |
| RO.....6.4 | 13.35 | T-141.....13.17, 13.29 | T-317.....13.37 | VF7000.....14.18 |
| RFS.....13.46 | T-12.....13.31, 13.33 | T-142.....13.16, 13.17 | T-319.....13.37 | XL-C/S.....10.9 |
| R-1.....13.37 | 13.35 | 13.29 | T-320.....13.37 | XF-45.....7.3 |
| R1.....6.4 | T-13.....13.31, 13.33 | T-150.....13.29 | T-321.....13.37 | XF-50.....7.3, 10.9 |
| R-2.....13.37 | 13.35 | T-150-1.....13.29 | T-326.....13.37 | |
| R2.....6.4 | T-14.....13.31, 13.35 | T-150-2.....13.29 | T-403.....13.19, 13.21 | |
| R2S.....6.2, 6.4 | T-15A.....13.31, 13.33 | T-201.....13.11, 13.13 | 13.23, 13.25 | |
| R3.....6.4 | 13.35 | 13.15, 13.17 | T-404.....13.19, 13.21 | |
| R4.....6.3, 6.4 | T-15B.....13.31, 13.33 | 13.27 | 13.23, 13.25 | |
| R-7.....13.37 | 13.35 | T-201A.....13.27 | T-406.....13.19, 13.21 | |
| R-8.....13.37 | T-16.....13.31, 13.33 | T-202.....13.11, 13.13 | 13.23, 13.25 | |
| RU16H.....13.44 | 13.35, 13.37 | 13.15, 13.17 | T-407.....13.19, 13.21 | |
| RUA25.....13.44 | T-17.....13.31, 13.33 | 13.27 | 13.23, 13.25 | |
| RU50K.....13.45 | 13.35, 13.37 | T-203.....13.11, 13.13 | T-408.....13.19, 13.21 | |
| RJ-98.....2.4 | T-18.....13.31, 13.33 | 13.15, 13.17 | 13.23, 13.25 | |
| RJ-99.....2.4 | 13.35, 13.37 | 13.27 | T-409.....13.19, 13.21 | |
| RT-100.....9.3 | T-21.....13.31, 13.33 | T-204.....13.11, 13.13 | 13.23, 13.25 | |
| RT-175.....9.3 | 13.35 | 13.17, 13.27 | T-411.....13.19, 13.21 | |
| rM200.....12.8 | T-22.....13.31, 13.33 | T-205.....13.11, 13.13 | 13.23, 13.25 | |
| rM200A.....12.8 | 13.35 | 13.15, 13.17 | T-412.....13.19, 13.21 | |
| rM200B.....12.8 | T-23.....13.31, 13.33 | 13.27 | 13.23, 13.25 | |
| RP 200-B.....10.2, 10.4 | 13.35, 13.37 | T-206.....13.11, 13.13 | T-413.....13.19, 13.21 | |
| RP 210-B.....10.2, 10.5 | T-24.....13.31, 13.33 | 13.15, 13.17 | 13.23, 13.25 | |
| RAPC250.....13.45 | 13.35, 13.37 | 13.27 | T-414.....13.19, 13.21 | |
| RP 330-B.....10.2 | T-25.....13.31, 13.33 | T-207.....13.15, 13.17 | 13.23, 13.25 | |
| RP 330-C.....10.2 | 13.35, 13.37 | 13.27 | T-416.....13.19, 13.21 | |
| RJ624.....2.5, 5.8 | T-26.....13.31, 13.33 | T-208.....13.15, 13.17 | 13.23, 13.25 | |
| R735BB.....11.7 | 13.35, 13.37 | 13.27 | T-432.....13.19, 13.21 | |
| R737BB.....11.7 | T-26A.....13.31, 13.33 | T-209.....13.15, 13.17 | 13.23, 13.25 | |
| R739BB.....11.7 | 13.35, 13.37 | 13.27 | T-433.....13.21, 13.23 | |
| RT1000.....6.8 | T-27.....13.31, 13.33 | T-210.....13.11, 13.13 | 13.25 | |
| RC-1625.....3.19 | 13.35, 13.37 | 13.15, 13.17 | T-434.....13.19, 13.21 | |
| RCB-1625.....3.19 | T-31.....13.31, 13.33 | 13.27 | 13.23, 13.25 | |
| RC-2375.....3.19 | 13.35 | T-211.....13.11, 13.13 | T-436.....13.19, 13.21 | |
| RCB-2375.....3.19 | T-32.....13.31, 13.33 | 13.15, 13.17 | 13.23, 13.25 | |
| RV2400A.....14.14 | 13.35 | 13.27 | T-458.....13.19, 13.21 | |
| RV2400HF.....14.9 | T-33.....13.31, 13.33 | T-212.....13.11, 13.13 | 13.23, 13.25 | |
| RV2600B.....14.15 | 13.35 | 13.15, 13.17 | T-468.....13.21, 13.23 | |
| RR3000.....13.43 | T-38.....13.31, 13.33 | 13.27 | 13.25 | |
| RV3410.....14.1 | 13.35 | T-213.....13.11, 13.13 | TP-4000.....13.46 | |
| RT3422.....6.9 | T-39.....13.31, 13.33 | 13.15, 13.17 | TP-5500.....13.46 | |
| S.....8.5 | 13.35 | 13.27 | V1.....10.10 | |
| S-1.....13.11, 13.13 | T-40.....13.31, 13.33 | T-214.....13.11, 13.13 | V2.....10.9, 10.10 | |
| S-2.....1.6, 13.11 | 13.35 | 13.15, 13.17 | V1/C1.....10.10 | |
| 13.13, 13.17 | T-41.....13.31, 13.33 | 13.27 | VJ-98.....2.4 | |
| S-3.....13.11, 13.13 | 13.35 | T-215.....13.11, 13.13 | VF-99.....2.4 | |
| 13.17 | T-42.....13.31, 13.33 | 13.15, 13.17 | VJ-99.....2.4 | |
| S-4A.....1.6 | 13.35 | 13.27 | VT1701.....14.16 | |
| S-6A.....1.6 | T-43.....13.31, 13.33 | T-216.....13.15, 13.17 | VT1702.....14.16 | |
| S-8A.....1.6 | 13.35 | 13.27 | VT1708.....14.16 | |
| S14.....7.13 | T-44.....13.31, 13.33 | T-217.....13.11, 13.13 | VT1709.....14.16 | |
| S18.....7.13 | 13.35 | 13.15, 13.17 | VT1710.....14.16 | |
| S24.....7.13 | T-45.....13.31, 13.33 | 13.27 | VT 1712.....14.16 | |
| S30.....7.13 | 13.35 | T-218.....13.27 | VT 1714.....14.16 | |
| S36.....7.13 | T-46.....13.31, 13.33 | T-219.....13.27 | VT 1720.....14.16 | |
| S42.....7.13 | 13.35 | T-220.....13.27 | VT 1755.....14.16 | |
| SC-60C.....11.4 | T-47.....13.31, 13.33 | T-221.....13.27 | VT1781.....14.16 | |
| SF-2500.....9.4 | T-50.....13.31, 13.33 | T-225.....13.11, 13.13 | VP2000.....14.21 | |
| T-1.....13.31, 13.33 | 13.35 | 13.17, 13.27 | VT 2501.....14.16 | |
| 13.35 | T-50-1.....13.31, 13.33 | T-230.....13.11, 13.13 | VT 2502.....14.16 | |
| | 13.35 | 13.17, 13.27 | VT 2503.....14.16 | |

CATALOG NUMBER INDEX

Catalog

| | | | | | | | | | | | |
|------------|--------------|------------|--------------|------------|--------------|------------|------------|------------|--------------|------------|--------------|
| 10251..... | 8.5 | 17567..... | 11.8 | 23487..... | 11.8 | 28098..... | 13.14 | 31410..... | 3.6 | 31723..... | 14.16 |
| 10261..... | 8.5 | 17572..... | 11.8 | 23488..... | 3.19 | 28103..... | 13.14 | 31420..... | 1.1 | 31725..... | 1.1 |
| 10271..... | 8.5 | 17577..... | 11.8 | 23492..... | 11.8 | 29583..... | 10.12 | 31425..... | 1.1 | 31728..... | 14.16 |
| 10281..... | 8.5 | 17582..... | 11.8 | 23493..... | 3.19 | 29798..... | 12.34 | 31430..... | 1.1 | 31730..... | 1.1 |
| 10291..... | 8.5 | 17587..... | 11.8 | 23498..... | 3.19 | 29848..... | 14.16 | 31435..... | 1.1 | 31733..... | 14.16 |
| 10301..... | 8.5 | 17592..... | 11.8 | 23692..... | 13.3 | 29963..... | 3.17, 3.18 | 31440..... | 1.1 | 31735..... | 1.1 |
| 10311..... | 8.5 | 17597..... | 11.7 | 23697..... | 13.3 | 29973..... | 3.17, 3.18 | 31442..... | 4.26 | 31738..... | 14.16 |
| 10321..... | 8.5 | 17602..... | 11.7 | 23702..... | 13.3 | 29983..... | 3.22 | 31445..... | 1.1 | 31740..... | 1.1 |
| 10341..... | 8.5 | 17861..... | 9.3 | 23707..... | 13.3 | 29993..... | 3.22 | 31450..... | 1.1 | 31743..... | 14.16 |
| 10343..... | 3.12, 3.13 | 18363..... | 7.13 | 23712..... | 13.3 | 30007..... | 13.29 | 31455..... | 1.1 | 31745..... | 1.1 |
| 10348..... | 1.3 | 18368..... | 7.13 | 23717..... | 13.3 | 30032..... | 8.5 | 31460..... | 1.1 | 31750..... | 1.1 |
| 10351..... | 8.5 | 18373..... | 7.13 | 23738..... | 14.2 | 30088..... | 3.19 | 31465..... | 1.1 | 31753..... | 12.6, 12.7 |
| 10358..... | 1.3 | 18378..... | 7.13 | 23743..... | 14.2 | 30093..... | 3.19 | 31470..... | 1.1 | 31755..... | 1.1 |
| 10361..... | 8.5 | 18383..... | 7.13 | 23908..... | 13.13 | 30118..... | 4.3 | 31475..... | 1.1 | 31760..... | 1.1 |
| 10883..... | 4.13 | 18388..... | 7.13 | 23913..... | 13.11, 13.13 | 30208..... | 12.24 | 31480..... | 1.1 | 31765..... | 1.1 |
| 10973..... | 3.13, 3.18 | 19238..... | 12.38 | 24226..... | 13.31, 13.33 | 30703..... | 5.4 | 31485..... | 1.1 | 31770..... | 1.1 |
| 11931..... | 4.12, 4.26 | 19258..... | 12.4 | 24537..... | 11.7 | 30708..... | 5.4 | 31487..... | 13.21, 13.23 | 31775..... | 1.1 |
| 12128..... | 13.17, 13.27 | 19263..... | 12.4 | 24542..... | 11.7 | 31000..... | 1.2 | | 13.25 | 31780..... | 1.1 |
| 12138..... | 4.19 | 19268..... | 12.4 | 24582..... | 11.7 | 31005..... | 1.2 | 31490..... | 1.1 | 31785..... | 1.1 |
| 12248..... | 12.6, 12.7 | 19273..... | 12.4 | 24587..... | 11.7 | 31010..... | 1.2 | 31492..... | 13.21, 13.23 | 31787..... | 11.7 |
| 12543..... | 12.37, 12.38 | 19366..... | 4.10 | 24608..... | 14.16 | 31015..... | 1.2 | | 13.25 | 31790..... | 1.1 |
| 12638..... | 3.13 | 19793..... | 12.4 | 24797..... | 8.7 | 31020..... | 1.2 | 31495..... | 1.1 | 31792..... | 11.7 |
| 12643..... | 3.13 | 19813..... | 10.7 | 24853..... | 13.14 | 31023..... | 10.5 | 31500..... | 1.1 | 31797..... | 11.7 |
| 12693..... | 1.3 | 20105..... | 4.24 | 25036..... | 13.31 | 31025..... | 1.2 | 31502..... | 8.7 | 31802..... | 11.7 |
| 12698..... | 1.3 | 20168..... | 12.39 | 25588..... | 3.19 | 31028..... | 10.5 | 31505..... | 1.1 | 31803..... | 3.17, 3.18 |
| 13988..... | 12.7 | 20213..... | 7.8 | 25638..... | 5.4 | 31030..... | 1.2 | 31510..... | 1.1 | 31807..... | 11.7 |
| 13998..... | 12.7 | 20218..... | 7.8 | 26092..... | 4.26 | 31035..... | 1.2 | 31515..... | 1.1 | 31817..... | 11.7 |
| 14053..... | 12.7 | 20233..... | 7.4 | 26097..... | 4.26 | 31038..... | 10.5 | 31520..... | 1.1 | 31822..... | 4.28 |
| 14058..... | 12.7 | 20238..... | 7.6 | 26112..... | 4.26 | 31040..... | 1.2 | 31525..... | 1.1 | 31827..... | 4.27 |
| 14063..... | 12.6 | 20248..... | 12.38 | 26122..... | 4.26 | 31045..... | 1.2 | 31530..... | 1.1 | 31832..... | 4.27 |
| 14078..... | 12.7 | 20483..... | 10.9 | 26127..... | 4.26 | 31048..... | 10.5 | 31535..... | 1.1 | 31948..... | 12.29 |
| 14083..... | 12.6 | 20543..... | 10.9 | 26132..... | 4.27 | 31050..... | 1.4 | 31555..... | 1.1 | 32078..... | 3.16, 3.17 |
| 14213..... | 7.13 | 20548..... | 10.9 | 26137..... | 4.27 | 31053..... | 10.5 | 31560..... | 1.1 | | 3.18 |
| 14218..... | 7.13 | 20553..... | 10.9 | 26142..... | 4.27 | 31055..... | 1.4 | 31565..... | 1.1 | 32237..... | 4.27 |
| 14223..... | 7.13 | 20923..... | 4.5, 4.14 | 26147..... | 4.27 | 31060..... | 1.4 | 31570..... | 1.1 | 32242..... | 4.27 |
| 14228..... | 7.13 | 20928..... | 4.5 | 26152..... | 4.27 | 31065..... | 1.4 | 31575..... | 1.1 | 32573..... | 3.15 |
| 14233..... | 7.13 | 20933..... | 4.5 | 26157..... | 4.27 | 31070..... | 1.4 | 31580..... | 1.1 | 32603..... | 12.5 |
| 14238..... | 7.13 | 20938..... | 4.5 | 26162..... | 4.27 | 31073..... | 14.16 | 31585..... | 1.1 | 32673..... | 12.14 |
| 14388..... | 3.13 | 20943..... | 4.5, 4.14 | 26163..... | 10.10 | 31075..... | 1.4 | 31590..... | 1.1 | 32703..... | 14.16 |
| 14818..... | 12.39 | 20948..... | 4.5 | 26167..... | 4.27 | 31078..... | 14.16 | 31595..... | 1.1 | 32737..... | 13.19, 13.21 |
| 14988..... | 3.6 | 20953..... | 4.5 | 26187..... | 4.27 | 31080..... | 1.4 | 31597..... | 8.7 | | 13.23, 13.25 |
| 15071..... | 8.5 | 20958..... | 4.5 | 26192..... | 4.27 | 31083..... | 14.16 | 31600..... | 1.1 | 32748..... | 12.5 |
| 15317..... | 4.7 | 20973..... | 12.39 | 26212..... | 4.27 | 31085..... | 1.4 | 31602..... | 8.7 | 32775..... | 1.1 |
| 15323..... | 12.7 | 21103..... | 10.9 | 26217..... | 4.27 | 31088..... | 14.16 | 31605..... | 1.1 | 32808..... | 4.12 |
| 15561..... | 6.5 | 21218..... | 4.4 | 26453..... | 14.21 | 31090..... | 1.2 | 31607..... | 8.7 | 32810..... | 3.7 |
| 15682..... | 4.17 | 21847..... | 11.7 | 26558..... | 13.11 | 31095..... | 1.2 | 31610..... | 1.1 | 32820..... | 3.2, 3.7 |
| 15722..... | 4.17 | 21857..... | 11.7 | 26573..... | 14.16 | 31100..... | 1.2 | 31612..... | 8.7 | 32825..... | 3.2 |
| 15828..... | 12.6 | 21878..... | 10.11 | 26578..... | 14.16 | 31103..... | 14.16 | 31615..... | 1.1 | 32828..... | 5.4 |
| 16202..... | 7.9 | 21893..... | 12.32 | 26648..... | 7.3 | 31105..... | 1.2 | 31617..... | 8.7 | 32830..... | 3.2, 3.7 |
| 16207..... | 7.9 | 21898..... | 12.32, 12.33 | 26707..... | 4.27 | 31108..... | 14.16 | 31620..... | 1.1 | 32833..... | 5.4 |
| 16276..... | 6.4 | | 12.34, 12.36 | 26773..... | 13.14 | 31110..... | 1.2 | 31622..... | 3.15, 3.18 | 32840..... | 3.2, 3.7 |
| 16473..... | 7.9 | 21903..... | 12.36 | 26778..... | 13.15 | 31115..... | 1.2 | 31625..... | 1.1 | 32845..... | 3.2 |
| 16573..... | 7.8 | 22088..... | 4.12 | 26803..... | 3.19 | 31120..... | 1.5 | 31627..... | 3.15 | 32850..... | 3.2, 3.7 |
| 16671..... | 6.2, 6.4 | 22163..... | 12.34 | 26993..... | 13.14 | 31125..... | 1.5 | 31630..... | 1.1 | 32870..... | 3.3, 3.7 |
| 16703..... | 2.2, 4.13 | 22168..... | 2.4 | 26998..... | 13.14 | 31128..... | 10.4 | 31632..... | 3.16, 3.18 | 32880..... | 3.3, 3.7 |
| | 4.14 | 22173..... | 12.32, 12.33 | 27003..... | 13.14 | 31130..... | 1.5 | 31635..... | 1.1 | 32895..... | 3.3, 3.7 |
| 16713..... | 13.43 | 22388..... | 12.37 | 27008..... | 13.14 | 31175..... | 1.8 | 31637..... | 3.16, 3.18 | 32900..... | 3.5, 3.7 |
| 16723..... | 4.10, 4.21 | 22563..... | 4.27 | 27013..... | 13.14 | 31180..... | 1.8 | 31640..... | 1.1 | 32905..... | 3.6 |
| 16728..... | 12.4 | 22638..... | 4.16, 4.17 | 27023..... | 1.1 | 31228..... | 10.7 | 31642..... | 3.16, 3.18 | 32910..... | 3.17, 3.18 |
| 16958..... | 10.7 | 22653..... | 10.9 | 27033..... | 13.14 | 31275..... | 1.5 | 31645..... | 1.1 | 32915..... | 3.17 |
| 16963..... | 10.7 | 22658..... | 10.9 | 27048..... | 13.15 | 31280..... | 1.5 | 31647..... | 3.16, 3.18 | 32920..... | 3.17, 3.18 |
| 16978..... | 10.7 | 22663..... | 10.9 | 27423..... | 10.1 | 31305..... | 1.5 | 31650..... | 1.1 | 32925..... | 3.17 |
| 17003..... | 10.7 | 22668..... | 10.9 | 27428..... | 10.1 | 31310..... | 1.6 | 31652..... | 3.16, 3.18 | 32930..... | 3.17, 3.18 |
| 17008..... | 10.7 | 22673..... | 10.9 | 27592..... | 13.3 | 31315..... | 1.6 | 31655..... | 1.1 | 32933..... | 3.15 |
| 17013..... | 10.7 | 22678..... | 10.9 | 27597..... | 13.3 | 31320..... | 1.6 | 31657..... | 3.16, 3.18 | 32935..... | 3.17 |
| 17018..... | 10.7 | 22683..... | 10.7 | 27612..... | 13.3 | 31325..... | 1.6 | 31660..... | 1.1 | 32940..... | 3.17, 3.18 |
| 17497..... | 11.8 | 22688..... | 10.7 | 27617..... | 13.3 | 31330..... | 1.6 | 31662..... | 3.16, 3.18 | 32950..... | 3.17 |
| 17502..... | 11.8 | 22958..... | 10.8 | 27637..... | 13.3 | 31335..... | 1.7 | 31665..... | 1.1 | 32975..... | 3.14, 3.18 |
| 17507..... | 11.8 | 22968..... | 10.8 | 27642..... | 13.17, 13.29 | 31340..... | 1.7 | 31667..... | 3.16, 3.18 | 32985..... | 3.14, 3.18 |
| 17512..... | 11.8 | 22973..... | 10.8 | 27848..... | 7.3 | 31345..... | 1.7 | 31670..... | 1.1 | 33005..... | 3.17, 3.18 |
| 17517..... | 11.8 | 22978..... | 10.8 | 27858..... | 3.19 | 31350..... | 1.7 | 31675..... | 1.1 | 33055..... | 3.16, 3.18 |
| 17522..... | 11.8 | 23282..... | 4.19, 4.25 | 27998..... | 10.2, 10.10 | 31355..... | 1.7 | 31680..... | 1.1 | 33057..... | 4.27 |
| 17527..... | 11.8 | 23297..... | 4.19, 4.25 | 28003..... | 10.2, 10.10 | 31360..... | 1.7 | 31685..... | 1.1 | 33070..... | 3.16 |
| 17532..... | 11.8 | | 4.28 | 28008..... | 10.2, 10.10 | 31365..... | 1.7 | 31690..... | 1.1 | 33072..... | 4.27 |
| 17537..... | 11.8 | 23332..... | 8.7 | 28013..... | 10.2, 10.10 | 31370..... | 1.7 | 31695..... | 1.1 | 33077..... | 4.27 |
| 17542..... | 11.8 | 23337..... | 8.7 | 28018..... | 10.2, 10.10 | 31375..... | 1.6 | 31700..... | 1.1 | 33085..... | 7.7 |
| 17547..... | 11.8 | 23448..... | 10.12 | 28023..... | 10.2, 10.10 | 31380..... | 1.6 | 31705..... | 1.1 | 33100..... | 3.7 |
| 17552..... | 11.8 | 23458..... | 10.12 | 28028..... | 10.10 | 31385..... | 1.6 | 31710..... | 1.1 | 33103..... | 12.1 |
| 17557..... | 11.8 | 23463..... | 10.12 | 28033..... | 10.10 | 31390..... | 1.6 | 31713..... | 14.16 | 33105..... | 3.7 |
| 17558..... | 12.6 | 23468..... | 10.12 | 28038..... | 10.10 | 31395..... | 1.4 | 31715..... | 1.1 | 33108..... | 12.10, 12.11 |
| 17562..... | 11.8 | 23477..... | 11.7 | 28043..... | 10.1 | 31400..... | 1.6, 6.8 | 31718..... | 14.16 | | 12.12 |
| 17563..... | 12.7 | 23478..... | 10.12 | 28048..... | 10.1 | 31405..... | 1.9 | 31720..... | 1.1 | 33110..... | 3.7 |

Catalog

| | | | | | |
|------------------------|-----------------------|-----------------------|------------------------|-----------------------|-----------------------|
| 33113.....12.10, 12.11 | 35275.....8.4 | 36122.....8.2 | 37088.....12.24 | 37575.....4.5 | 37960.....4.7 |
| 12.12 | 35280.....8.4 | 36127.....8.2 | 37093.....12.25 | 37580.....4.5 | 37963.....10.2, 10.11 |
| 33115.....3.7 | 35285.....8.4 | 36132.....8.2 | 37095.....4.5 | 37585.....4.5 | 37965.....4.7 |
| 33120.....3.7 | 35290.....8.4 | 36158.....12.27 | 37098.....12.25 | 37590.....4.5 | 37968.....10.2, 10.11 |
| 33125.....3.7, 4.26 | 35338.....12.9 | 36163.....12.29 | 37100.....4.5 | 37595.....4.5 | 37970.....4.7 |
| 33130.....3.7 | 35343.....10.9 | 36248.....7.4 | 37103.....12.23, 12.24 | 37610.....4.5 | 37973.....10.2, 10.11 |
| 33135.....3.7 | 35473.....13.12 | 36253.....7.4 | 37105.....4.5 | 37615.....4.5 | 37975.....4.7 |
| 33145.....3.7 | 35535.....7.11 | 36258.....7.4 | 37108.....12.23, 12.24 | 37618.....8.9 | 37978.....10.2, 10.11 |
| 33150.....3.7 | 35540.....7.11 | 36273.....2.2, 4.13 | 37110.....4.5 | 37620.....4.5 | 37980.....4.7 |
| 33155.....3.7 | 35545.....7.11 | 4.14 | 37113.....12.23, 12.24 | 37625.....4.5 | 37983.....10.2, 10.11 |
| 33160.....3.18 | 35550.....7.11 | 36278.....2.2 | 37115.....4.5 | 37628.....13.19 | 37985.....4.7 |
| 33165.....3.18 | 35555.....7.11 | 36345.....4.3 | 37120.....4.5 | 37630.....4.5 | 37988.....10.11 |
| 33170.....3.18 | 35560.....7.11 | 36355.....4.3 | 37123.....12.23 | 37633.....13.19 | 37993.....10.11 |
| 33175.....3.12, 3.13 | 35565.....7.11 | 36375.....4.3 | 37125.....4.5 | 37635.....4.5 | 37997.....2.4 |
| 3.18 | 35570.....7.11 | 36390.....4.3 | 37130.....4.5 | 37638.....13.19 | 38003.....10.11 |
| 33180.....3.18 | 35575.....7.11 | 36475.....4.3 | 37135.....4.5 | 37640.....4.5 | 38008.....10.11 |
| 33185.....3.18 | 35580.....7.11 | 36480.....4.3 | 37140.....4.5 | 37643.....13.19 | 38028.....8.3 |
| 33190.....3.18 | 35585.....7.11 | 36505.....4.3 | 37145.....4.5 | 37645.....4.5 | 38033.....8.3 |
| 33195.....3.18 | 35590.....7.12 | 36510.....4.3 | 37150.....4.5 | 37650.....4.5 | 38038.....8.3 |
| 33198.....12.14, 12.5 | 35600.....3.8 | 36518.....8.8 | 37155.....4.5 | 37655.....4.5 | 38043.....8.3 |
| 33200.....3.18 | 35605.....3.8 | 36523.....8.8 | 37160.....4.5 | 37675.....4.5 | 38048.....8.3 |
| 33205.....3.18 | 35610.....3.8 | 36540.....4.4 | 37165.....4.5 | 37695.....4.5 | 38050.....4.7 |
| 33210.....3.18 | 35615.....3.8 | 36550.....4.4 | 37170.....4.5 | 37710.....4.5 | 38053.....8.3 |
| 33220.....3.7 | 35620.....3.8 | 36555.....4.4 | 37175.....4.5 | 37715.....4.5 | 38055.....4.7 |
| 33225.....3.7 | 35625.....3.8 | 36560.....4.4 | 37180.....4.5 | 37720.....4.5 | 38058.....8.3 |
| 33551.....3.12, 3.13 | 35630.....3.8 | 36565.....4.8 | 37185.....4.5 | 37725.....4.5 | 38060.....4.7 |
| 3.18 | 35670.....3.8 | 36570.....4.8 | 37190.....4.5 | 37730.....4.5 | 38063.....8.3 |
| 33642.....4.27 | 35675.....3.8 | 36592.....3.16, 3.18 | 37195.....4.5 | 37735.....4.5 | 38065.....4.7 |
| 33665.....3.4, 3.6 | 35680.....3.8 | 36597.....3.16, 3.18 | 37223.....8.9 | 37740.....4.5 | 38070.....4.7 |
| 33922.....13.3 | 35685.....3.8 | 36620.....4.1 | 37228.....8.9 | 37745.....4.5 | 38075.....4.7 |
| 33927.....8.7 | 35695.....7.11 | 36630.....4.1 | 37233.....8.9 | 37753.....13.24 | 38078.....8.9 |
| 34077.....4.3 | 35700.....7.12 | 36653.....12.5, 12.19 | 37238.....8.9 | 37755.....4.5 | 38080.....4.7 |
| 34082.....4.3 | 35720.....7.12 | 36662.....3.12, 3.13 | 37243.....8.9 | 37775.....4.5 | 38083.....8.9 |
| 34087.....4.3 | 35725.....7.12 | 36663.....12.19 | 37248.....8.9 | 37777.....4.3 | 38085.....4.7 |
| 34092.....4.3 | 35730.....7.12 | 36680.....4.4 | 37253.....8.9 | 37780.....4.5 | 38100.....4.8 |
| 34100.....6.9 | 35735.....7.12 | 36690.....4.4 | 37258.....8.9 | 37785.....4.5 | 38105.....4.8 |
| 34142.....3.21 | 35740.....7.12 | 36738.....12.23 | 37263.....8.9 | 37790.....4.5 | 38110.....4.8 |
| 34147.....3.21 | 35745.....7.12 | 36798.....12.26 | 37273.....8.9 | 37795.....4.5 | 38120.....4.11 |
| 34152.....8.5 | 35750.....7.12 | 36813.....12.28 | 37278.....8.9 | 37800.....4.5 | 38125.....4.11 |
| 34157.....4.27 | 35755.....7.12 | 36875.....4.5 | 37293.....8.9 | 37805.....4.5 | 38130.....4.11 |
| 34162.....4.27 | 35760.....7.12 | 36880.....4.5 | 37348.....12.21 | 37810.....4.7 | 38140.....4.11 |
| 34167.....4.27 | 35765.....7.12 | 36885.....4.5 | 37375.....4.5 | 37813.....8.9 | 38155.....4.11 |
| 34172.....4.27 | 35770.....7.12 | 36890.....4.5 | 37380.....4.5 | 37815.....4.7 | 38220.....4.8 |
| 34177.....4.27 | 35775.....7.12 | 36895.....4.5 | 37385.....4.5 | 37820.....4.7 | 38225.....4.8 |
| 34182.....4.27 | 35780.....7.12 | 36900.....4.5 | 37390.....4.5 | 37825.....4.7 | 38230.....4.8 |
| 34318.....12.1 | 35785.....7.12 | 36935.....4.5 | 37395.....4.5 | 37828.....8.9 | 38235.....4.8 |
| 34403.....10.14 | 35790.....7.12 | 36940.....4.5 | 37400.....4.5 | 37830.....4.7 | 38240.....4.8 |
| 34570.....3.5 | 35795.....7.12 | 36942.....8.2 | 37405.....4.5 | 37835.....4.7 | 38245.....4.8 |
| 34577.....4.27 | 35800.....7.12 | 36945.....4.5 | 37410.....4.5 | 37840.....4.7 | 38250.....4.8 |
| 34612.....4.22, 4.23 | 35805.....7.12 | 36947.....8.2 | 37413.....13.42 | 37842.....13.17 | 38255.....4.8 |
| 34617.....3.7 | 35810.....7.12 | 36950.....4.5 | 37415.....4.5 | 37845.....4.7 | 38335.....4.7 |
| 34623.....12.11 | 35815.....3.8 | 36952.....8.2 | 37435.....4.5 | 37847.....13.17 | 38340.....4.7 |
| 34678.....10.14 | 35820.....3.8 | 36955.....4.5 | 37440.....4.5 | 37850.....4.7 | 38345.....4.7 |
| 34695.....3.18 | 35825.....3.8 | 36957.....8.2 | 37445.....4.5 | 37852.....13.17 | 38350.....4.7 |
| 34893.....13.9 | 35830.....3.8 | 36960.....4.5 | 37450.....4.5 | 37855.....4.7 | 38355.....4.7 |
| 34945.....3.8 | 35835.....3.8 | 36962.....8.2 | 37455.....4.5 | 37857.....13.17 | 38360.....4.7 |
| 34950.....3.8 | 35840.....3.8 | 36965.....4.5 | 37460.....4.5 | 37860.....4.7 | 38365.....4.7 |
| 34955.....3.8 | 35845.....3.8 | 36967.....8.2 | 37465.....4.5 | 37862.....13.17 | 38370.....4.7 |
| 34960.....3.8 | 35850.....3.8 | 36970.....4.5 | 37468.....12.5, 12.10 | 37865.....4.7 | 38375.....4.7 |
| 34963.....13.9 | 35855.....3.8 | 36972.....8.2 | 37470.....4.5 | 37867.....13.17 | 38380.....4.7 |
| 34965.....3.22 | 35867.....4.31 | 36975.....4.5 | 37473.....12.5, 12.10 | 37870.....4.7 | 38385.....4.7 |
| 35133.....12.11 | 35973.....12.19 | 36980.....4.5 | 37475.....4.5 | 37875.....4.7 | 38390.....4.7 |
| 35143.....12.11 | 35983.....12.5, 12.19 | 36985.....4.5 | 37480.....4.5 | 37880.....4.7 | 38395.....4.7 |
| 35155.....3.22 | 35998.....13.12 | 36990.....4.5 | 37483.....12.1 | 37885.....4.7 | 38400.....4.7 |
| 35170.....8.4 | 36003.....13.12 | 36995.....4.5 | 37485.....4.5 | 37888.....12.5, 12.10 | 38405.....4.7 |
| 35175.....8.4 | 36005.....3.21 | 37000.....4.5 | 37490.....4.5 | 12.11, 12.12 | 38410.....4.7 |
| 35180.....8.4 | 36008.....13.12 | 37005.....4.5 | 37495.....4.5 | 12.24 | 38415.....4.7 |
| 35183.....12.5, 12.11 | 36013.....13.12 | 37010.....4.5 | 37500.....4.5 | 37890.....4.7 | 38420.....4.7 |
| 35188.....12.5, 12.11 | 36018.....13.12 | 37015.....4.5 | 37505.....4.5 | 37895.....4.7 | 38425.....4.7 |
| 35215.....11.12 | 36023.....13.12 | 37020.....4.5 | 37510.....4.5 | 37900.....4.7 | 38535.....4.3 |
| 35220.....11.12 | 36028.....13.12 | 37025.....4.5 | 37515.....4.5 | 37905.....4.7 | 38540.....4.3 |
| 35225.....11.12 | 36033.....13.12 | 37030.....4.5 | 37520.....4.5 | 37910.....4.7 | 38550.....4.3 |
| 35230.....11.12 | 36038.....13.12 | 37035.....4.5 | 37525.....4.5 | 37915.....4.7 | 38568.....8.9 |
| 35235.....11.12 | 36043.....13.12 | 37040.....4.5, 4.13 | 37530.....4.5 | 37920.....4.7 | 38605.....4.4 |
| 35240.....11.12 | 36048.....13.12 | 4.14 | 37535.....4.5 | 37925.....4.7 | 38610.....4.4 |
| 35243.....12.11 | 36053.....13.12 | 37045.....4.5, 4.13 | 37540.....4.5 | 37930.....4.7 | 38615.....4.4 |
| 35245.....8.4 | 36058.....13.12 | 4.14 | 37545.....4.5 | 37935.....4.7 | 38620.....4.4 |
| 35250.....8.4 | 36092.....8.2 | 37050.....4.5, 4.13 | 37550.....4.5 | 37940.....4.7 | 38625.....4.4 |
| 35255.....8.4 | 36097.....8.2 | 4.14 | 37555.....4.5 | 37945.....4.7 | 38693.....13.43 |
| 35260.....8.4 | 36102.....8.2 | 37055.....4.5, 4.13 | 37560.....4.5 | 37950.....4.7 | 38698.....13.43 |
| 35265.....8.4 | 36112.....8.2 | 4.14 | 37565.....4.5 | 37955.....4.7 | 38703.....13.43 |
| 35270.....8.4 | 36117.....8.2 | 37083.....12.24 | 37570.....4.5 | 37958.....10.2, 10.11 | 38708.....13.43 |

CATALOG NUMBER INDEX

Catalog

| | | | | | | | | | | | |
|-------|--------------|-------|--------------|-------|--------------|-------|--------------|-------|--------------|-------|--------------|
| 38713 | 13.43 | 41860 | 4.16 | 44202 | 13.2 | 47268 | 13.45 | 48285 | 4.29 | 48930 | 4.3 |
| 38718 | 13.43 | 41935 | 4.15 | 44212 | 13.2 | 47273 | 13.45 | 48290 | 4.29 | 48935 | 4.3 |
| 38723 | 13.43 | 41937 | 13.17 | 44217 | 13.2 | 47278 | 13.44 | 48292 | 5.6 | 48940 | 4.3 |
| 39187 | 4.14 | 41940 | 4.15 | 44468 | 10.6 | 47283 | 13.44 | 48295 | 4.29 | 48945 | 4.3 |
| 39328 | 12.5, 12.15 | 41977 | 13.2 | 44473 | 12.33 | 47427 | 13.21, 13.23 | 48297 | 5.6 | 48950 | 4.3 |
| 39338 | 12.15 | 41982 | 13.21, 13.25 | 44483 | 10.6 | | 13.25 | 48305 | 4.29 | 48955 | 4.3 |
| 39380 | 4.1 | 41992 | 13.21, 13.23 | 44587 | 13.34 | 47432 | 13.21, 13.23 | 48307 | 5.5 | 48960 | 4.3 |
| 39587 | 4.28 | | 13.25 | 44693 | 10.4, 10.5 | | 13.25 | 48310 | 4.29 | 48965 | 4.3 |
| 39966 | 9.3 | 42002 | 13.2 | | 10.6, 11.3 | 47528 | 12.8 | 48315 | 4.29 | 48970 | 4.3 |
| 39976 | 9.3 | 42007 | 13.2 | | 12.9, 12.19 | 47538 | 12.8 | 48320 | 4.29 | 48973 | 11.9 |
| 39998 | 12.12 | 42012 | 13.2 | 44698 | 10.4, 10.5 | 47542 | 13.38, 13.39 | 48325 | 4.29 | 48975 | 4.3 |
| 40005 | 4.10 | 42047 | 4.25 | | 10.6, 11.3 | | 13.41, 13.43 | 48330 | 4.29 | 48983 | 11.9 |
| 40008 | 12.5, 12.12 | 42052 | 4.25 | | 12.9 | 47548 | 12.8 | 48335 | 4.29 | 48985 | 4.3 |
| 40028 | 12.24 | 42057 | 4.25 | 44798 | 10.4, 10.5 | 47597 | 13.38, 13.39 | 48340 | 4.29 | 48988 | 11.9 |
| 40043 | 12.22 | 42062 | 4.25 | | 10.6, 11.3 | | 13.41, 13.43 | 48345 | 4.29 | 49002 | 13.17 |
| 40068 | 14.19 | 42067 | 4.25 | 44848 | 10.4, 10.5 | 47602 | 13.38, 13.39 | 48350 | 4.29 | 49032 | 13.19, 13.21 |
| 40073 | 14.19 | 42072 | 4.25 | | 10.6, 12.14 | | 13.41, 13.43 | 48355 | 4.29 | | 13.23, 13.25 |
| 40080 | 2.3 | 42077 | 4.25 | | 12.15, 12.16 | 47607 | 13.38, 13.39 | 48360 | 4.29 | 49215 | 4.29 |
| 40090 | 2.3 | 42082 | 4.25 | 44852 | 8.3 | | 13.41 | 48367 | 13.38, 13.39 | 49220 | 4.29 |
| 40100 | 2.3 | 42087 | 4.25 | 44853 | 10.4, 10.5 | 47663 | 13.46 | | 13.41, 13.43 | 49225 | 4.29 |
| 40110 | 2.3 | 42153 | 8.7 | | 10.6, 12.14 | 47668 | 13.47 | 48373 | 11.9 | 49230 | 4.29 |
| 40125 | 2.3 | 42163 | 13.8 | | 12.15, 12.16 | 47673 | 13.47 | 48375 | 4.29 | 49240 | 4.29 |
| 40130 | 2.2 | 42323 | 12.13 | 44913 | 4.13 | 47678 | 13.47 | 48377 | 5.6 | 49245 | 4.29 |
| 40153 | 14.2 | 42328 | 12.13 | | 4.13 | 47735 | 4.28 | 48382 | 5.6 | 49250 | 4.29 |
| 40158 | 14.18 | 42333 | 12.13 | 44918 | 4.13 | 47740 | 4.28 | 48387 | 5.6 | 49272 | 13.38, 13.39 |
| 40163 | 14.16 | 42348 | 12.8 | 44923 | 4.14 | 47745 | 4.17, 4.21 | 48392 | 5.6 | | 13.41, 13.43 |
| 40165 | 2.2 | 42360 | 4.16, 4.17 | 44928 | 4.14 | | 4.22, 4.23 | 48397 | 5.6 | 49277 | 13.38, 13.39 |
| 40168 | 14.16 | 42365 | 4.16, 4.17 | 44992 | 4.27 | | 4.26, 4.28 | 48402 | 5.6 | | 13.41, 13.43 |
| 40170 | 2.3 | | 4.19, 4.21 | 44997 | 4.27 | 47750 | 4.17, 4.21 | 48405 | 5.6, 5.7 | 49305 | 4.3 |
| 40175 | 2.2 | 42370 | 4.16 | 45002 | 4.27 | | 4.22, 4.23 | 48407 | 5.6, 5.7 | 49338 | 12.35 |
| 40180 | 2.2 | 42385 | 4.16 | 45007 | 5.5 | | 4.26, 4.28 | 48412 | 5.6, 5.7 | 49345 | 4.29 |
| 40185 | 2.2 | 42390 | 4.21 | 45138 | 12.16 | 47753 | 11.5 | 48417 | 5.6, 5.7 | 49408 | 11.4 |
| 40190 | 2.2 | 42405 | 4.10, 4.21 | 45143 | 12.16 | 47755 | 4.28 | 48457 | 13.33 | 49487 | 13.38, 13.39 |
| 40195 | 2.2 | 42415 | 4.10, 4.21 | 45158 | 12.9, 12.16 | 47760 | 4.28 | 48462 | 13.34 | | 13.41 |
| 40200 | 2.2 | 42478 | 7.13 | 45163 | 12.9, 12.16 | 47765 | 4.19, 4.28 | 48472 | 13.29 | 49528 | 12.13 |
| 40205 | 2.2 | 42485 | 4.19, 4.25 | 45178 | 4.15 | 47770 | 4.19, 4.28 | 48477 | 13.29 | 49585 | 4.3 |
| 40210 | 2.2 | 42490 | 4.19, 4.25 | 45317 | 13.32 | 47775 | 4.28 | 48482 | 13.27 | 49600 | 4.3 |
| 40215 | 2.2 | 42505 | 2.5, 4.10 | 45347 | 5.5 | 47780 | 4.28 | 48488 | 12.6 | 49610 | 4.3 |
| 40220 | 2.3 | 42510 | 2.5 | 45352 | 5.5 | 47785 | 4.28 | 48533 | 12.6 | 49662 | 5.6 |
| 40225 | 2.3 | 42575 | 4.16, 4.17 | 45358 | 12.25 | 47790 | 4.28 | 48543 | 12.7 | 49707 | 4.7 |
| 40230 | 2.3 | | 5.8 | 45363 | 12.16 | 47793 | 12.9 | 48553 | 10.11 | 49712 | 4.7 |
| 40235 | 2.3 | 42600 | 4.15 | 45848 | 4.7 | 47810 | 4.28 | 48558 | 10.11 | 49717 | 4.7 |
| 40593 | 12.1 | 42605 | 4.15 | 45853 | 4.7 | 47815 | 4.28 | 48563 | 10.11 | 49722 | 4.7 |
| 40598 | 12.9 | 42610 | 4.15 | 45858 | 4.7 | 47820 | 4.28 | 48605 | 4.3 | 49727 | 4.7 |
| 40617 | 3.14, 3.18 | 42615 | 4.15 | 45863 | 4.7 | 47845 | 4.28 | 48610 | 4.3 | 49795 | 4.3 |
| 40788 | 12.1 | 42620 | 4.15 | 45868 | 4.7 | 47850 | 4.28 | 48615 | 4.3 | 49805 | 4.3 |
| 40798 | 12.11 | 42625 | 4.15 | 45873 | 4.7 | 47855 | 4.28 | 48620 | 4.3 | 49815 | 4.3 |
| 40808 | 12.11 | 42878 | 3.5 | 45878 | 4.7 | 47860 | 4.28 | 48625 | 4.3 | 49820 | 4.3 |
| 40818 | 12.12 | 42950 | 4.15 | 45883 | 4.7 | 47880 | 4.28 | 48630 | 4.3 | 49825 | 4.3 |
| 40868 | 3.2 | 43138 | 12.8 | 45888 | 4.7 | 47885 | 4.28 | 48635 | 4.3 | 49830 | 4.3 |
| 40938 | 3.21 | 43348 | 10.6 | 45923 | 4.13 | 47890 | 4.28 | 48640 | 4.3 | 49835 | 4.3 |
| 41162 | 8.6 | 43353 | 10.6 | 45928 | 4.14 | 47895 | 4.28 | 48645 | 4.3 | 49840 | 4.3 |
| 41185 | 4.19 | 43358 | 10.6 | 46015 | 13.21, 4.19 | 47900 | 4.28 | 48650 | 4.3 | 49845 | 4.3 |
| 41212 | 13.21, 13.23 | 43363 | 10.6 | | 4.21, 4.23 | 47905 | 4.28 | 48655 | 4.3 | 49850 | 4.3 |
| | 13.25 | 43368 | 10.6 | 46030 | 4.19, 4.21 | 47910 | 4.28 | 48660 | 4.3 | 49870 | 4.3 |
| 41285 | 8.8 | 43373 | 10.6 | | 4.23, 4.26 | 47918 | 11.4 | 48665 | 4.3 | 49875 | 4.3 |
| 41295 | 8.8 | 43378 | 10.6 | 46040 | 4.26 | 47923 | 11.4 | 48670 | 4.3 | 49890 | 4.3 |
| 41300 | 8.8 | 43428 | 10.4 | 46045 | 4.23 | 47928 | 11.4 | 48675 | 4.3 | 49895 | 4.3 |
| 41315 | 8.8 | 43433 | 10.4 | 46105 | 3.13 | 47940 | 4.28 | 48680 | 4.3 | 49900 | 4.3 |
| 41320 | 8.8 | 43438 | 10.4 | 46190 | 4.26 | 48093 | 12.9 | 48690 | 4.3 | 49905 | 4.3 |
| 41325 | 8.8 | 43443 | 10.4 | 46660 | 4.16 | 48103 | 12.9 | 48695 | 4.3 | 49915 | 4.3 |
| 41330 | 8.8 | 43448 | 10.4 | 46668 | 4.13 | 48113 | 12.9 | 48700 | 4.3 | 49925 | 4.3 |
| 41335 | 8.8 | 43453 | 10.4 | 46673 | 4.14 | 48123 | 12.17, 12.18 | 48705 | 4.3 | 49930 | 4.3 |
| 41340 | 8.8 | 43458 | 10.4, 10.5 | 46683 | 13.6 | 48133 | 12.17, 12.18 | 48710 | 4.3 | 49932 | 4.6 |
| 41345 | 8.8 | | 10.6, 11.3 | 46708 | 12.9 | 48143 | 12.9 | 48713 | 1.3 | 49937 | 4.6 |
| 41348 | 13.9 | | 12.9, 12.19 | 46713 | 12.9 | 48148 | 12.9 | 48715 | 4.3 | 49942 | 4.6 |
| 41350 | 8.8 | 43507 | 13.32 | 46732 | 4.8 | 48153 | 12.9 | 48718 | 1.3 | 49947 | 4.6 |
| 41408 | 13.8 | 43512 | 13.32 | 46737 | 4.8 | 48157 | 13.41, 13.43 | 48720 | 4.3 | 49952 | 4.6 |
| 41438 | 14.21 | 43573 | 3.22 | 46742 | 4.8 | 48215 | 4.29 | 48725 | 4.3 | 49962 | 4.6 |
| 41575 | 4.12 | 43637 | 13.21, 13.25 | 46747 | 4.8 | 48220 | 4.29 | 48730 | 4.3 | 49967 | 4.6 |
| 41585 | 4.12 | 43642 | 13.21, 13.25 | 46753 | 1.8 | 48225 | 4.29 | 48735 | 4.3 | 49972 | 1.1 |
| 41590 | 4.12 | 43647 | 13.19, 13.20 | 46818 | 11.3 | 48230 | 4.29 | 48740 | 4.3 | 50002 | 13.38, 13.39 |
| 41598 | 14.16 | | 13.21, 13.23 | 46837 | 13.32 | 48235 | 4.29 | 48745 | 4.3 | | 13.41, 13.43 |
| 41600 | 4.12 | | 13.25 | 46852 | 5.5 | 48240 | 4.29 | 48755 | 4.3 | 50007 | 13.38, 13.39 |
| 41603 | 14.16 | 43853 | 10.12 | 46902 | 13.32 | 48245 | 4.29 | 48858 | 3.23 | | 13.41, 13.43 |
| 41608 | 3.2 | 43858 | 10.12 | 46907 | 13.32 | 48250 | 4.29 | 48868 | 3.23 | 50012 | 4.28 |
| 41610 | 4.12 | 44117 | 13.21, 13.23 | 46918 | 12.32 | 48255 | 4.29 | 48888 | 3.23 | 50040 | 4.3 |
| 41697 | 13.21, 13.23 | | 13.25 | 47047 | 13.2 | 48260 | 4.29 | 48893 | 3.23 | 50050 | 4.3 |
| | 13.25 | 44122 | 13.19, 13.21 | 47057 | 1.2 | 48265 | 4.29 | 48898 | 3.23 | 50060 | 4.3 |
| 41703 | 3.21 | | 13.23, 13.25 | 47082 | 6.6 | 48270 | 4.29 | 48915 | 4.3 | 50070 | 4.3 |
| 41768 | 3.21 | 44185 | 3.7, 4.21 | 47087 | 6.6 | 48275 | 4.29 | 48920 | 4.3 | 50075 | 4.3 |
| 41855 | 4.16, 4.17 | 44190 | 3.7 | 47222 | 5.6 | 48280 | 4.29 | 48925 | 4.3 | 50080 | 4.3 |

Catalog

| | | | | | |
|------------------------|------------------------|--------------------|------------------------|------------------------|------------------------|
| 50085.....4.3 | 51005.....4.31 | 52455.....7.5 | 52957.....13.38, 13.39 | 54655.....11.11 | 59240.....13.31, 13.33 |
| 50090.....4.3 | 51020.....4.31 | 52458.....11.9 | 52960.....6.5 | 54695.....11.11 | 13.35 |
| 50095.....4.3 | 51022.....6.6 | 52463.....11.9 | 52962.....13.27 | 54837.....13.17 | 59250.....13.27 |
| 50100.....4.3 | 51035.....4.31 | 52465.....7.5 | 52965.....6.5 | 54842.....13.17, 13.29 | 59255.....13.27 |
| 50105.....4.3 | 51040.....4.31 | 52468.....11.9 | 52970.....6.5 | 54852.....13.17, 13.29 | 59265.....13.27 |
| 50110.....4.3 | 51045.....4.31 | 52470.....7.5 | 52972.....13.26 | 54975.....11.11 | 59270.....13.27 |
| 50115.....4.3 | 51050.....4.31 | 52473.....11.9 | 52975.....6.5 | 54992.....13.17 | 59295.....13.37 |
| 50120.....4.3 | 51055.....4.31 | 52475.....7.5 | 52980.....6.5 | 55002.....13.17 | 59300.....13.31, 13.33 |
| 50125.....4.3 | 51060.....4.31 | 52478.....11.9 | 52985.....6.5 | 55007.....13.17 | 13.35 |
| 50130.....4.3 | 51065.....4.31 | 52480.....7.5 | 52990.....6.5 | 55012.....13.17 | 59320.....13.31, 13.33 |
| 50140.....4.3 | 51070.....4.31 | 52483.....11.9 | 52995.....6.5 | 55017.....13.17 | 13.35 |
| 50257.....8.6 | 51075.....4.31 | 52485.....7.5 | 53000.....6.5 | 55207.....4.3 | 59325.....13.31, 13.33 |
| 50308.....14.3 | 51206.....8.5 | 52488.....11.9 | 53037.....13.38, 13.39 | 55447.....4.27 | 59360.....13.19 |
| 50313.....14.2 | 51317.....13.15, 13.27 | 52490.....7.5 | 53065.....6.4 | 55452.....4.27 | 59365.....13.27, 13.29 |
| 50318.....14.7 | 13.29 | 52493.....11.9 | 53068.....12.37 | 55457.....13.17 | 59370.....13.27 |
| 50323.....14.4 | 51402.....13.2 | 52495.....7.5 | 53070.....6.4 | 55467.....13.17 | 59395.....13.31, 13.33 |
| 50328.....14.8 | 51407.....13.2 | 52498.....11.9 | 53075.....6.4 | 56337.....4.7 | 13.35 |
| 50333.....14.12 | 51507.....6.7 | 52503.....11.9 | 53080.....6.4 | 56342.....4.7 | 59400.....13.31, 13.33 |
| 50338.....14.13 | 51512.....6.7 | 52505.....7.5 | 53085.....6.4 | 56347.....4.7 | 13.35 |
| 50343.....14.11 | 51522.....6.7 | 52508.....11.9 | 53107.....13.16 | 56352.....4.7 | 59415.....13.31, 13.33 |
| 50348.....14.5 | 51527.....6.7 | 52513.....11.9 | 53112.....13.16 | 56367.....4.7 | 13.35 |
| 50353.....14.6 | 51537.....6.7 | 52518.....11.9 | 53117.....13.16 | 56488.....11.3 | 59425.....13.29 |
| 50358.....14.14 | 51547.....6.7 | 52523.....11.9 | 53122.....13.16 | 56498.....11.3 | 59440.....13.31, 13.33 |
| 50363.....14.15 | 51557.....6.7 | 52528.....11.9 | 53127.....13.16 | 56503.....11.3 | 13.35 |
| 50368.....14.9 | 51572.....13.38, 13.39 | 52533.....11.9 | 53548.....11.5 | 56508.....11.3 | 59445.....13.29 |
| 50373.....14.1 | 13.41 | 52538.....11.9 | 53553.....11.5 | 56558.....10.13 | 59450.....13.27 |
| 50480.....4.3 | 51587.....13.38, 13.39 | 52543.....11.9 | 53558.....11.5 | 56568.....10.13 | 59462.....13.16 |
| 50482.....7.1 | 13.41 | 52548.....11.9 | 53563.....11.5 | 56573.....10.13 | 59470.....13.31, 13.33 |
| 50485.....4.3 | 51597.....13.38, 13.39 | 52553.....11.9 | 53568.....11.5 | 56578.....10.13 | 59475.....13.31, 13.33 |
| 50487.....7.1 | 13.41 | 52558.....11.9 | 53573.....11.5 | 56583.....10.13 | 13.35 |
| 50490.....4.3 | 51752.....13.17 | 52563.....11.9 | 53578.....11.5 | 56588.....10.13 | 59480.....13.31, 13.33 |
| 50495.....4.3 | 51762.....13.19, 13.21 | 52568.....11.9 | 53583.....11.5 | 56593.....10.13 | 13.35 |
| 50500.....4.3 | 13.23, 13.25 | 52573.....11.9 | 53588.....11.5 | 56598.....10.13 | 59485.....13.31, 13.33 |
| 50505.....4.3 | 51778.....7.13 | 52578.....11.9 | 53593.....11.5 | 56603.....10.13 | 13.35 |
| 50510.....4.3 | 51803.....14.1 | 52583.....11.9 | 53598.....11.5 | 56608.....10.13 | 59502.....6.3, 6.4 |
| 50515.....4.3 | 51808.....14.1 | 52588.....11.9 | 53603.....11.5 | 56638.....10.13 | 59512.....3.10, 3.9 |
| 50520.....4.3 | 51857.....4.5 | 52755.....6.5 | 53608.....11.5 | 56653.....10.13 | 3.10 |
| 50525.....4.3 | 51862.....4.5 | 52760.....6.5, 6.8 | 53613.....11.5 | 56657.....2.4 | 59517.....3.9, 3.10 |
| 50530.....4.3 | 51867.....4.5 | 6.9 | 53618.....11.5 | 56662.....2.4 | 59555.....13.37 |
| 50540.....4.3 | 51872.....4.5 | 52765.....6.5 | 53623.....11.5 | 56667.....2.4 | 59560.....13.37 |
| 50545.....4.3 | 51877.....4.5 | 52770.....6.5 | 53628.....11.5 | 56672.....2.4 | 59562.....13.22 |
| 50550.....4.3 | 51882.....4.5 | 52775.....6.5 | 53633.....11.5 | 56682.....2.4 | 59625.....13.31, 13.33 |
| 50557.....9.2 | 52078.....11.6 | 52780.....6.5, 6.8 | 53638.....11.5 | 56782.....13.17 | 13.35 |
| 50560.....4.3 | 52083.....11.3 | 6.9 | 53643.....11.5 | 56787.....13.17 | 59765.....13.37 |
| 50575.....4.3 | 52088.....11.3 | 52785.....6.5 | 53648.....11.5 | 56792.....13.17 | 59770.....13.37 |
| 50585.....4.3 | 52093.....11.3 | 52790.....6.5 | 53653.....11.5 | 56797.....13.17 | 59775.....13.37 |
| 50590.....4.3 | 52098.....11.3 | 52795.....6.5 | 53658.....11.5 | 56847.....7.6 | 59780.....13.37 |
| 50633.....3.23 | 52103.....11.3 | 52800.....6.5, 6.9 | 53663.....11.5 | 56852.....7.6 | 59787.....13.6 |
| 50645.....4.28 | 52108.....11.3 | 52805.....6.5 | 53668.....11.5 | 56892.....6.6 | 59797.....13.6 |
| 50647.....13.11, 13.13 | 52113.....11.3 | 52810.....6.5 | 53673.....11.5 | 56897.....6.6 | 59802.....13.6 |
| 50650.....4.28 | 52118.....11.3 | 52812.....13.17 | 53678.....11.5 | 57492.....4.27 | 59812.....13.8 |
| 50652.....13.17 | 52123.....11.3 | 52815.....6.5 | 53683.....11.5 | 57497.....4.27 | 59835.....13.37 |
| 50657.....13.17 | 52133.....11.3 | 52817.....13.17 | 53688.....11.5 | 57502.....4.27 | 59917.....13.17 |
| 50700.....4.28 | 52192.....4.29 | 52820.....6.5, 6.9 | 53693.....4.26 | 57507.....4.27 | 59992.....5.6, 5.7 |
| 50705.....4.28 | 52202.....4.29 | 52822.....13.17 | 54115.....7.9 | 57592.....6.3 | 60002.....3.9 |
| 50710.....4.28 | 52217.....4.29 | 52825.....6.5 | 54120.....7.9 | 57597.....6.3 | 60032.....13.23 |
| 50715.....4.28 | 52278.....11.6 | 52830.....6.5 | 54125.....7.9 | 58007.....4.21 | 60037.....13.23 |
| 50720.....4.28 | 52283.....11.4 | 52835.....6.5 | 54135.....11.11 | 58192.....13.19 | 60042.....13.23 |
| 50725.....4.28 | 52300.....7.1 | 52840.....6.5 | 54253.....10.13 | 58222.....3.9 | 60047.....13.23 |
| 50730.....4.28 | 52305.....7.1 | 52845.....6.5 | 54270.....11.11 | 58227.....3.1 | 60052.....13.22 |
| 50735.....4.28 | 52310.....7.1 | 52850.....6.5, 6.9 | 54278.....11.1 | 58657.....3.7, 4.22 | 60062.....13.22 |
| 50740.....4.28 | 52315.....7.1 | 52855.....6.5 | 54283.....11.1 | 58712.....4.27 | 60087.....13.17 |
| 50745.....4.28 | 52343.....13.15 | 52860.....6.5 | 54288.....11.1 | 58747.....8.5 | 60355.....13.37 |
| 50750.....4.28 | 52363.....13.14 | 52865.....6.5 | 54293.....11.1 | 58752.....4.23 | 60360.....13.37 |
| 50755.....4.28 | 52368.....11.6 | 52870.....6.5 | 54298.....11.1 | 58757.....4.23 | 60365.....13.37 |
| 50760.....4.28 | 52373.....11.6 | 52875.....6.5 | 54397.....3.9 | 58890.....13.8 | 60382.....5.5 |
| 50765.....4.28 | 52378.....11.6 | 52880.....6.5 | 54440.....11.11 | 58895.....13.8 | 60700.....13.37 |
| 50767.....3.9 | 52383.....11.6 | 52885.....6.5 | 54445.....11.11 | 58920.....13.26 | 60776.....9.4 |
| 50770.....4.28 | 52388.....11.6 | 52890.....6.5 | 54450.....11.11 | 58960.....13.26 | 61102.....13.22 |
| 50775.....4.28 | 52420.....8.6 | 52895.....6.5 | 54465.....11.11 | 58980.....13.26 | 61107.....13.23 |
| 50780.....4.28 | 52423.....11.9 | 52900.....6.5 | 54480.....11.11 | 59000.....13.26 | 61122.....4.10, 4.27 |
| 50785.....4.28 | 52425.....8.6 | 52905.....6.5 | 54490.....11.11 | 59132.....6.3 | 61142.....4.22 |
| 50812.....3.9 | 52428.....11.9 | 52910.....6.5 | 54500.....11.11 | 59175.....13.36 | 61187.....4.22 |
| 50895.....4.28 | 52430.....8.6 | 52915.....6.5 | 54505.....11.11 | 59190.....13.7 | 61522.....13.22 |
| 50900.....4.28 | 52433.....11.9 | 52920.....6.5 | 54515.....11.11 | 59205.....13.37 | 61542.....13.22 |
| 50905.....4.28 | 52435.....8.6 | 52925.....6.5 | 54520.....11.11 | 59210.....13.27, 13.29 | 61615.....13.29 |
| 50910.....4.28 | 52438.....11.9 | 52930.....6.5 | 54535.....11.11 | 59225.....13.17, 13.29 | 61625.....13.31, 13.33 |
| 50915.....4.28 | 52440.....8.6 | 52935.....6.5 | 54540.....11.11 | 13.31, 13.33 | 61630.....13.31, 13.33 |
| 50920.....4.28 | 52443.....11.9 | 52940.....6.5 | 54580.....11.11 | 13.35, 13.37 | 61757.....3.9 |
| 50960.....4.29 | 52448.....11.9 | 52945.....6.5 | 54625.....11.11 | 59230.....13.17 | 61770.....13.31, 13.33 |
| 50965.....4.29 | 52450.....7.5 | 52950.....6.5 | 54630.....11.11 | 59235.....13.27 | 13.35 |
| 50985.....4.29 | 52453.....11.9 | 52955.....6.5 | 54650.....11.11 | | 61790.....13.37 |

CATALOG NUMBER INDEX

Catalog

| | | | | | | | | | | | |
|------------|--------------|------------|--------------|------------|--------------|------------|--------------|------------|--------------|------------|------------|
| 61800..... | 13.37 | 62862..... | 9.3 | 63882..... | 13.4 | 65960..... | 4.6 | 66800..... | 4.28 | 70655..... | 4.11 |
| 61820..... | 13.7 | 62865..... | 13.17, 13.29 | 64077..... | 13.41 | 65965..... | 4.6 | 66805..... | 4.28 | 70677..... | 8.7 |
| 61825..... | 13.31, 13.33 | 62870..... | 13.17, 13.29 | 64497..... | 12.7 | 65970..... | 4.6 | 66807..... | 1.9 | 70685..... | 4.7 |
| | 13.35 | 62875..... | 13.17, 13.29 | 64502..... | 12.7 | 65975..... | 4.6 | 66810..... | 4.28 | 70690..... | 4.7 |
| 61850..... | 13.37 | 62877..... | 13.39, 13.41 | 64607..... | 12.7 | 65980..... | 4.6 | 66830..... | 4.28 | 70695..... | 4.7 |
| 61855..... | 13.37 | 62880..... | 13.17, 13.29 | 64612..... | 12.7 | 65985..... | 4.6 | 66880..... | 4.28 | 70700..... | 4.7 |
| 61875..... | 13.37 | 62882..... | 13.38, 13.39 | 64627..... | 12.7 | 65990..... | 4.6 | 66905..... | 4.28 | 70705..... | 4.7 |
| 61885..... | 13.37 | | 13.41, 13.43 | 64642..... | 2.5 | 66020..... | 4.6 | 66920..... | 4.28 | 70710..... | 4.7 |
| 61960..... | 13.37 | 62892..... | 13.38 | 64697..... | 13.38, 13.39 | 66030..... | 4.6 | 66947..... | 4.23 | 70715..... | 4.7 |
| 61970..... | 13.31, 13.33 | 62897..... | 13.39 | 64702..... | 13.38, 13.39 | 66035..... | 4.6 | 66955..... | 4.28 | 70720..... | 4.7 |
| | 13.35 | 62915..... | 13.29 | 64707..... | 13.38 | 66040..... | 4.6 | 66987..... | 7.2 | 70725..... | 4.7 |
| 61975..... | 13.31, 13.35 | 62920..... | 13.29 | 64712..... | 13.38 | 66045..... | 4.6 | 66992..... | 7.2 | 70730..... | 4.7 |
| 62045..... | 13.37 | 62925..... | 13.29 | 64717..... | 13.38 | 66050..... | 4.6 | 66997..... | 7.2 | 70740..... | 4.28 |
| 62050..... | 13.37 | 62930..... | 13.17, 13.29 | 64722..... | 13.38 | 66055..... | 4.6 | 67182..... | 4.23 | 70745..... | 4.28 |
| 62055..... | 13.37 | 62935..... | 13.17, 13.29 | 64727..... | 13.38 | 66060..... | 4.6 | 67187..... | 13.38, 13.39 | 70750..... | 4.28 |
| 62060..... | 13.37 | 62940..... | 13.17, 13.29 | 64732..... | 13.38, 13.39 | 66065..... | 4.6 | | 13.41, 13.43 | 70755..... | 4.28 |
| 62065..... | 13.37 | 62990..... | 13.17 | | 13.41, 13.43 | 66110..... | 4.7 | 67307..... | 12.6 | 70760..... | 4.28 |
| 62067..... | 13.27 | 62995..... | 13.17 | 64737..... | 13.38, 13.39 | 66125..... | 4.7 | 67312..... | 12.6 | 70830..... | 4.12 |
| 62075..... | 13.37 | 63000..... | 13.17 | | 13.41 | 66130..... | 4.7 | 67322..... | 12.6 | 70835..... | 4.12, 4.21 |
| 62080..... | 13.37 | 63005..... | 13.17 | 64742..... | 13.39 | 66150..... | 4.7 | 67327..... | 12.6 | | 4.22, 4.23 |
| 62095..... | 13.37 | 63010..... | 13.17 | 64747..... | 13.39 | 66155..... | 4.7 | 67332..... | 13.39 | | 4.26 |
| 62105..... | 13.37 | 63015..... | 13.17 | 64752..... | 13.39 | 66160..... | 4.7 | 67615..... | 4.3 | 71687..... | 3.11 |
| 62110..... | 13.37 | 63020..... | 13.17 | 64757..... | 13.39 | 66175..... | 4.7 | 67620..... | 4.3 | 71692..... | 3.11 |
| 62115..... | 13.37 | 63025..... | 13.17 | 64762..... | 13.39 | 66190..... | 4.7 | 67625..... | 4.3 | 71697..... | 3.11 |
| 62125..... | 13.37 | 63030..... | 13.17 | 64767..... | 13.41 | 66195..... | 4.7 | 67635..... | 4.3 | 71702..... | 13.1 |
| 62140..... | 13.37 | 63035..... | 13.17 | 64772..... | 13.41 | 66200..... | 4.7 | 67640..... | 4.3 | 71717..... | 13.1 |
| 62170..... | 13.37 | 63040..... | 13.17 | 64777..... | 13.41 | 66205..... | 4.7 | 67645..... | 4.3 | 71722..... | 13.1 |
| 62225..... | 13.27 | 63045..... | 13.17 | 64782..... | 13.41 | 66210..... | 4.7 | 67650..... | 4.3 | 71727..... | 13.1 |
| 62235..... | 13.27 | 63050..... | 13.17 | 64787..... | 13.41 | 66215..... | 4.7 | 67655..... | 4.3 | 71732..... | 13.1 |
| 62245..... | 13.27 | 63055..... | 13.17 | 64792..... | 13.41 | 66220..... | 4.7 | 67657..... | 4.23, 4.24 | 71757..... | 13.11 |
| 62250..... | 13.27 | 63060..... | 13.17 | 64797..... | 13.43 | 66225..... | 4.7 | 67660..... | 4.3 | 71847..... | 13.11 |
| 62260..... | 13.27 | 63065..... | 13.17 | 64832..... | 13.43 | 66230..... | 4.7 | 67662..... | 4.23, 5.5 | 72327..... | 4.12 |
| 62265..... | 13.27, 13.29 | 63070..... | 13.27 | 64837..... | 13.43 | 66310..... | 4.7 | 67665..... | 4.3 | 72332..... | 4.12 |
| 62270..... | 13.27, 13.29 | 63075..... | 13.31, 13.33 | 64842..... | 13.43 | 66315..... | 4.7 | 67675..... | 4.3 | 72342..... | 4.12 |
| 62275..... | 13.31 | | 13.35 | 64847..... | 13.43 | 66320..... | 4.7 | 67685..... | 4.3 | 72702..... | 13.11 |
| 62280..... | 13.31, 13.33 | 63080..... | 13.27 | 64857..... | 13.43 | 66325..... | 4.7 | 67880..... | 4.29 | 72887..... | 14.16 |
| | 13.35 | 63085..... | 13.37 | 64862..... | 13.43 | 66330..... | 4.7 | 67885..... | 4.29 | 72897..... | 14.16 |
| 62285..... | 13.31, 13.33 | 63090..... | 13.31, 13.33 | 64902..... | 13.43 | 66335..... | 4.7 | 67890..... | 4.29 | 72902..... | 14.16 |
| | 13.35 | | 13.35 | 64962..... | 3.22 | 66340..... | 4.7 | 67900..... | 4.29 | 72907..... | 14.16 |
| 62295..... | 13.31, 13.33 | 63105..... | 13.31, 13.33 | 64967..... | 3.22 | 66345..... | 4.7 | 67905..... | 4.29 | 72912..... | 14.16 |
| | 13.35 | | 13.35 | 64977..... | 5.7 | 66350..... | 4.7 | 67910..... | 4.29 | 72922..... | 14.16 |
| 62300..... | 13.31, 13.33 | 63107..... | 13.38 | 65175..... | 4.3 | 66405..... | 4.7 | 67915..... | 4.29 | 72927..... | 14.16 |
| | 13.35 | 63110..... | 13.31, 13.33 | 65255..... | 4.3 | 66410..... | 4.7 | 67920..... | 4.29 | 72932..... | 14.16 |
| 62347..... | 7.9 | | 13.35 | 65285..... | 4.3 | 66415..... | 4.7 | 67925..... | 4.29 | 72937..... | 14.16 |
| 62352..... | 7.9 | 63112..... | 13.38 | 65320..... | 4.4 | 66420..... | 4.7 | 67935..... | 4.29 | 72947..... | 14.17 |
| 62362..... | 7.9 | 63115..... | 13.31, 13.33 | 65340..... | 4.8 | 66425..... | 4.7 | 67945..... | 4.29 | 72952..... | 14.17 |
| 62370..... | 13.37 | | 13.35 | 65345..... | 4.8 | 66430..... | 4.7 | 67955..... | 4.29 | 73162..... | 3.3, 3.7 |
| 62385..... | 13.37 | 63120..... | 13.31, 13.33 | 65380..... | 4.1 | 66435..... | 4.7 | 68160..... | 4.31 | 73360..... | 7.7 |
| 62390..... | 13.37 | | 13.35 | 65550..... | 4.6 | 66445..... | 4.7 | 68165..... | 4.31 | 73365..... | 7.7 |
| 62412..... | 13.17 | 63145..... | 13.31, 13.33 | 65555..... | 4.6 | 66450..... | 4.8 | 68170..... | 4.31 | 73370..... | 7.7 |
| 62457..... | 4.31 | | 13.35 | 65560..... | 4.6 | 66492..... | 13.28 | 68175..... | 4.31 | 73447..... | 4.23 |
| 62467..... | 13.31, 13.33 | 63150..... | 13.31, 13.33 | 65565..... | 4.6 | 66497..... | 13.28 | 68180..... | 4.31 | 74012..... | 4.12, 4.19 |
| 62472..... | 13.31, 13.33 | | 13.35 | 65570..... | 4.6 | 66512..... | 13.28 | 68185..... | 4.31 | 74047..... | 4.12 |
| 62530..... | 13.7 | 63155..... | 13.31, 13.33 | 65575..... | 4.6 | 66517..... | 13.28 | 68650..... | 3.4, 3.7 | 74207..... | 3.6, 3.7 |
| 62535..... | 13.7 | | 13.35 | 65580..... | 4.6 | 66535..... | 4.8 | 68775..... | 4.5 | 74227..... | 3.3, 3.7 |
| 62540..... | 13.7 | 63160..... | 13.31, 13.33 | 65620..... | 4.6 | 66540..... | 4.8 | 68780..... | 4.5 | 74685..... | 3.3, 3.7 |
| 62545..... | 13.7 | | 13.35 | 65625..... | 4.6 | 66550..... | 4.8 | 68815..... | 4.16, 4.17 | 74700..... | 3.3, 3.7 |
| 62555..... | 13.7 | 63165..... | 13.31, 13.33 | 65630..... | 4.6 | 66620..... | 4.11 | 68842..... | 9.4 | 74710..... | 3.3, 3.7 |
| 62565..... | 13.7 | | 13.35 | 65635..... | 4.6 | 66625..... | 4.11 | 68847..... | 9.4 | 74720..... | 3.18 |
| 62587..... | 13.38 | 63170..... | 13.31, 13.33 | 65640..... | 4.6 | 66655..... | 4.28 | 68857..... | 9.4 | 74730..... | 3.18 |
| 62592..... | 13.38, 13.39 | | 13.35 | 65680..... | 4.6 | 66660..... | 4.28 | 68862..... | 9.4 | 74735..... | 3.18 |
| 62595..... | 13.7 | 63175..... | 13.31, 13.33 | 65685..... | 4.6 | 66665..... | 4.17, 4.23 | 68917..... | 13.11, 13.13 | 74946..... | 9.4 |
| 62597..... | 13.38 | | 13.35 | 65687..... | 13.29 | | 4.26, 4.28 | 68962..... | 9.4 | 75005..... | 4.6 |
| 62605..... | 13.7 | 63180..... | 13.31, 13.33 | 65690..... | 4.6 | 66670..... | 4.17, 4.26 | 68967..... | 9.4 | 75010..... | 4.6 |
| 62615..... | 13.7 | | 13.35 | 65695..... | 4.6 | | 4.28 | 69250..... | 13.22 | 75015..... | 4.6 |
| 62625..... | 13.7 | 63185..... | 13.31, 13.33 | 65700..... | 4.6 | 66687..... | 3.9 | 69622..... | 7.3 | 75020..... | 4.6 |
| 62662..... | 9.5 | 63190..... | 13.31, 13.33 | 65705..... | 4.6 | 66700..... | 4.28 | 69632..... | 7.3 | 75075..... | 4.16, 4.17 |
| 62687..... | 13.39 | | 13.35 | 65710..... | 4.6 | 66705..... | 4.28 | 69642..... | 7.3 | 75435..... | 4.16 |
| 62697..... | 13.39 | 63195..... | 13.31, 13.33 | 65715..... | 4.6 | 66710..... | 4.28 | 69667..... | 5.5 | 75557..... | 3.7 |
| 62747..... | 9.5 | | 13.35 | 65720..... | 4.6 | 66732..... | 13.41, 13.43 | 69692..... | 5.5 | 75562..... | 3.7 |
| 62757..... | 13.38, 13.39 | 63200..... | 13.37 | 65725..... | 4.6 | 66737..... | 3.15 | 69707..... | 9.4 | 75567..... | 3.7 |
| 62772..... | 9.5 | 63205..... | 13.31, 13.33 | 65730..... | 4.6 | 66742..... | 3.15 | 69712..... | 9.4 | 75572..... | 3.7 |
| 62802..... | 9.5 | | 13.35 | 65765..... | 4.6 | 66747..... | 3.16 | 69717..... | 9.4 | 75602..... | 4.23 |
| 62812..... | 9.5 | 63210..... | 13.31, 13.33 | 65770..... | 4.6 | 66750..... | 4.28 | 69762..... | 9.3 | 75982..... | 6.9 |
| 62815..... | 13.37 | | 13.35 | 65775..... | 4.6 | 66755..... | 4.28 | 69907..... | 7.2 | 75992..... | 6.9 |
| 62840..... | 13.31, 13.33 | 63220..... | 13.27 | 65780..... | 4.6 | 66760..... | 4.28 | 69912..... | 7.2 | 76017..... | 6.9 |
| | 13.35 | 63240..... | 13.31, 13.33 | 65785..... | 4.6 | 66765..... | 4.28 | 69982..... | 3.4, 3.7 | 76022..... | 6.8, 6.9 |
| 62845..... | 13.31, 13.33 | | 13.35 | 65790..... | 4.6 | 66770..... | 4.28 | 70032..... | 13.17 | 76027..... | 6.9 |
| | 13.35 | 63280..... | 13.27 | 65902..... | 5.7 | 66775..... | 4.28 | 70437..... | 3.4 | 76032..... | 6.9 |
| 62850..... | 13.17, 13.29 | 63822..... | 13.16 | 65942..... | 9.4, 9.4 | 66780..... | 4.28 | 70640..... | 4.11 | 76037..... | 6.9 |
| 62855..... | 13.17, 13.29 | 63827..... | 13.16 | 65950..... | 4.6 | 66785..... | 4.28 | 70645..... | 4.11 | 76042..... | 6.9 |
| 62860..... | 13.29 | 63877..... | 13.4 | 65955..... | 4.6 | 66795..... | 4.28 | 70652..... | 9.4 | 76047..... | 6.9 |

Catalog #

| | | | | | | | | | |
|------------|--------------|------------|----------|------------|--------------|------------|--------------|------------|--------------|
| 76052..... | 6.9 | 83322..... | 6.8 | 92442..... | 5.3 | 93387..... | 12.7 | 98072..... | 13.11, 13.13 |
| 76057..... | 6.9 | 83327..... | 6.8 | 92447..... | 5.3 | 93392..... | 12.6 | 98170..... | 6.7 |
| 76067..... | 6.9 | 83337..... | 6.8 | 92452..... | 5.3 | 93492..... | 3.12, 3.18 | 98185..... | 6.7 |
| 76072..... | 6.9 | 83347..... | 6.8 | 92457..... | 4.27 | 93497..... | 5.3 | 98215..... | 6.7 |
| 76077..... | 6.9 | 83380..... | 2.5 | 92460..... | 13.19, 13.21 | 93557..... | 13.18 | 98220..... | 6.7 |
| 76082..... | 6.9 | 83407..... | 13.11 | 92462..... | 13.23, 13.25 | 93642..... | 5.3 | 98225..... | 6.7 |
| 76132..... | 6.9 | 83417..... | 13.11 | 92466..... | 4.27 | 93707..... | 3.12, 3.13 | 98240..... | 6.7 |
| 76137..... | 6.9 | 83435..... | 4.5 | 92465..... | 13.19, 13.21 | 93712..... | 3.12, 3.13 | 98250..... | 6.7 |
| 76142..... | 6.9 | 83450..... | 4.5 | 92467..... | 13.23, 13.25 | 93717..... | 3.12, 3.13 | 98265..... | 6.7 |
| 76147..... | 6.9 | 83455..... | 4.5 | 92470..... | 4.27 | 93722..... | 3.12, 3.13 | 98690..... | 6.7 |
| 76152..... | 6.9 | 83460..... | 4.5 | 92475..... | 13.19, 13.20 | 93727..... | 3.12, 3.13 | 98695..... | 6.7 |
| 76267..... | 6.8, 6.9 | 83465..... | 4.5 | 92477..... | 13.21, 13.23 | 93732..... | 3.12, 3.13 | 98700..... | 6.7 |
| 76272..... | 6.8, 6.9 | 83470..... | 4.5 | 92480..... | 13.25 | 93737..... | 3.12, 3.13 | 98705..... | 6.7 |
| 76277..... | 6.9 | 83475..... | 4.5 | 92485..... | 13.21, 13.23 | 93742..... | 3.12, 3.13 | 98710..... | 6.7 |
| 76282..... | 6.9 | 83480..... | 4.5 | 92490..... | 13.25 | 93747..... | 3.12, 3.13 | 98715..... | 6.7 |
| 76287..... | 6.9 | 83485..... | 4.5 | 92495..... | 13.21, 13.22 | 93757..... | 5.3 | 98720..... | 6.7 |
| 76292..... | 6.8, 6.9 | 83557..... | 13.24 | 92500..... | 13.25 | 93785..... | 7.6 | 99545..... | 4.29 |
| 76297..... | 6.8, 6.9 | 83567..... | 6.8 | 92495..... | 13.19, 13.20 | 93790..... | 7.6 | | |
| 76302..... | 6.9 | 83572..... | 6.8 | 92500..... | 13.21, 13.22 | 93907..... | 1.1 | | |
| 76305..... | 4.7 | 83975..... | 4.26 | 92505..... | 13.23, 13.24 | 93912..... | 1.1 | | |
| 76307..... | 6.9 | 83997..... | 6.9 | 92510..... | 13.25 | 93917..... | 1.1 | | |
| 76312..... | 6.9 | 84002..... | 6.9 | 92515..... | 13.19, 13.21 | 93922..... | 1.1 | | |
| 76315..... | 4.7 | 84007..... | 6.9 | 92520..... | 13.23, 13.25 | 94220..... | 4.29 | | |
| 76317..... | 6.8, 6.9 | 84012..... | 6.9 | 92525..... | 13.19, 13.21 | 94492..... | 13.29 | | |
| 76322..... | 6.8, 6.9 | 84097..... | 4.19 | 92530..... | 13.19, 13.20 | 94682..... | 3.12, 3.13 | | |
| 76327..... | 6.9 | 84295..... | 13.36 | 92535..... | 13.21, 13.22 | 94687..... | 3.12, 3.13 | | |
| 76332..... | 6.9 | 84325..... | 13.27 | 92540..... | 13.23, 13.25 | 95732..... | 13.18 | | |
| 76337..... | 6.9 | 84332..... | 4.11 | 92545..... | 13.19, 13.21 | 95737..... | 13.18, 13.19 | | |
| 76455..... | 13.26 | 84337..... | 4.11 | 92550..... | 13.22, 13.23 | 95782..... | 5.8 | | |
| 76475..... | 13.26 | 84417..... | 9.3 | 92555..... | 13.25 | 95792..... | 13.19 | | |
| 76485..... | 13.26 | 84427..... | 6.2, 6.3 | 92560..... | 13.19, 13.21 | 95797..... | 13.19 | | |
| 76495..... | 13.26 | 84532..... | 4.22 | 92565..... | 13.19, 13.21 | 95802..... | 13.19 | | |
| 76575..... | 13.29 | 84537..... | 4.22 | 92570..... | 13.23, 13.25 | 95807..... | 13.19 | | |
| 76597..... | 13.11 | 85830..... | 4.7 | 92575..... | 13.19, 13.21 | 95812..... | 13.19 | | |
| 76652..... | 10.8 | 85835..... | 4.7 | 92580..... | 13.19, 13.21 | 95822..... | 13.19 | | |
| 76657..... | 10.8 | 85850..... | 4.3 | 92585..... | 13.19, 13.21 | 95847..... | 13.11 | | |
| 76662..... | 10.8 | 85855..... | 4.3 | 92590..... | 13.23, 13.25 | 95872..... | 6.6 | | |
| 76667..... | 10.8 | 85865..... | 4.3 | 92595..... | 13.19, 13.21 | 95877..... | 6.6 | | |
| 76672..... | 10.8 | 85870..... | 4.3 | 92600..... | 13.23, 13.25 | 96037..... | 13.27 | | |
| 76677..... | 10.8 | 85957..... | 13.46 | 92605..... | 13.19, 13.21 | 96372..... | 2.5, 5.8 | | |
| 76767..... | 4.12 | 85962..... | 13.46 | 92610..... | 13.23, 13.25 | 96397..... | 3.18 | | |
| 76777..... | 6.2 | 85987..... | 13.44 | 92615..... | 13.19, 13.21 | 96497..... | 4.21 | | |
| 76787..... | 6.2 | 86127..... | 3.15 | 92620..... | 13.23, 13.25 | 96502..... | 4.21 | | |
| 76792..... | 6.2 | 86902..... | 1.7 | 92625..... | 13.19, 13.21 | 96507..... | 4.21 | | |
| 76817..... | 13.11, 13.13 | 86907..... | 1.7 | 92630..... | 13.23, 13.25 | 96517..... | 4.21 | | |
| 76822..... | 5.6 | 86912..... | 1.7 | 92635..... | 13.19 | 96720..... | 4.8 | | |
| 76827..... | 5.6 | 86917..... | 1.7 | 92640..... | 13.21, 13.22 | 96725..... | 4.1 | | |
| 77017..... | 6.2 | 86922..... | 1.7 | 92645..... | 13.23, 13.25 | 96945..... | 4.17 | | |
| 78347..... | 13.1 | 86927..... | 1.7 | 92650..... | 4.6 | 96967..... | 12.37 | | |
| 79120..... | 4.3 | 86932..... | 1.7 | 92655..... | 4.6 | 96982..... | 5.8 | | |
| 80475..... | 7.9 | 87107..... | 7.4 | 92660..... | 4.6 | 96987..... | 5.8 | | |
| 80480..... | 6.6 | 87577..... | 13.17 | 92665..... | 4.6 | 96992..... | 5.8 | | |
| 80485..... | 6.6 | 87582..... | 13.17 | 92670..... | 4.6 | 96997..... | 5.8 | | |
| 80500..... | 6.6 | 87587..... | 13.17 | 92675..... | 13.15 | 97045..... | 4.22 | | |
| 80505..... | 6.6 | 87592..... | 13.17 | 92680..... | 4.6 | 97050..... | 4.23 | | |
| 80510..... | 6.6 | 87597..... | 13.17 | 92685..... | 1.7 | 97065..... | 4.23 | | |
| 80515..... | 6.6 | 88232..... | 5.3 | 92690..... | 1.7 | 97070..... | 4.23 | | |
| 80520..... | 6.6 | 88260..... | 3.18 | 92695..... | 1.7 | 97075..... | 4.23 | | |
| 81280..... | 7.7 | 89400..... | 13.27 | 92700..... | 1.7 | 97080..... | 4.23 | | |
| 81490..... | 6.4 | 89405..... | 13.27 | 92705..... | 1.7 | 97212..... | 3.17, 3.18 | | |
| 81495..... | 6.4 | 89410..... | 13.13 | 92710..... | 13.15 | 97245..... | 4.17 | | |
| 81500..... | 6.4 | 89435..... | 1.5 | 92715..... | 1.7 | 97365..... | 4.16, 4.21 | | |
| 81505..... | 6.4 | 89440..... | 1.5 | 92720..... | 13.17 | 97375..... | 4.4 | | |
| 82832..... | 13.38 | 89445..... | 1.5 | 92725..... | 4.5 | 97415..... | 4.17 | | |
| 82837..... | 13.39 | 90107..... | 1.4 | 92730..... | 4.5 | 97420..... | 4.17 | | |
| 82842..... | 13.41 | 90117..... | 1.4 | 92735..... | 4.5 | 97457..... | 14.18 | | |
| 82852..... | 13.41 | 90122..... | 1.4 | 92740..... | 4.5 | 97462..... | 12.6 | | |
| 83037..... | 8.7 | 90127..... | 1.4 | 92745..... | 4.5 | 97787..... | 3.14, 3.18 | | |
| 83080..... | 3.3, 3.7 | 90702..... | 13.46 | 92750..... | 4.5 | 97832..... | 12.7 | | |
| 83085..... | 3.3, 3.7 | 90707..... | 13.46 | 92755..... | 13.21, 13.23 | 97852..... | 12.7 | | |
| 83140..... | 3.7 | 90995..... | 3.3 | 92760..... | 13.25 | 97882..... | 4.10, 4.19 | | |
| 83145..... | 3.3, 3.7 | 91027..... | 13.32 | 92765..... | 13.21, 13.23 | 98030..... | 13.31, 13.33 | | |
| 83150..... | 3.3, 3.7 | 91032..... | 13.32 | 92770..... | 13.25 | 98035..... | 13.35 | | |
| 83165..... | 3.3, 3.7 | 91037..... | 13.17 | 92775..... | 13.22 | 98040..... | 13.31, 13.33 | | |
| 83170..... | 3.3, 3.7 | 91042..... | 13.17 | 92780..... | 13.22 | 98045..... | 13.31, 13.33 | | |
| 83235..... | 3.18 | 91047..... | 13.19 | 92785..... | 13.22 | | | | |
| 83240..... | 3.17, 3.18 | 91142..... | 4.19 | 92790..... | 13.21, 13.23 | | | | |
| 83290..... | 3.17, 3.18 | 91192..... | 6.9 | 92795..... | 13.25 | | | | |
| 83295..... | 3.17, 3.18 | 91322..... | 4.19 | 92800..... | 13.21, 13.23 | | | | |
| 83302..... | 6.8 | 92095..... | 13.27 | 92805..... | 13.25 | | | | |
| 83307..... | 6.8 | 92100..... | 13.27 | 92810..... | 13.21 | | | | |
| 83317..... | 6.8 | 92437..... | 5.3 | 92815..... | 13.23 | | | | |
| | | | | 92820..... | 13.25 | | | | |
| | | | | 92825..... | 13.22 | | | | |
| | | | | 92830..... | 13.22 | | | | |
| | | | | 92835..... | 13.22 | | | | |
| | | | | 92840..... | 13.22 | | | | |
| | | | | 92845..... | 13.21 | | | | |
| | | | | 92850..... | 13.21, 13.23 | | | | |
| | | | | 92855..... | 13.25 | | | | |
| | | | | 92860..... | 13.21, 13.23 | | | | |
| | | | | 92865..... | 13.25 | | | | |
| | | | | 92870..... | 13.21 | | | | |
| | | | | 92875..... | 13.21 | | | | |
| | | | | 92880..... | 4.21 | | | | |

TERMS AND CONDITIONS OF SALE

Ridge Tool Company is herein referred to as "Ridge" and the customer or person or entity purchasing goods or services (hereinafter collectively referred to as "Goods") is referred to as the "Buyer". These Terms and Conditions, any price list or schedule, quotation, acknowledgment or invoice from Ridge relevant to the sale of the Goods and all documents incorporated by specific reference therein, constitute the complete and exclusive statement of the terms of the agreement governing the sale of Goods by Ridge to Buyer. Buyer's acceptance of the Goods will manifest Buyer's assent to these terms and conditions without variation or addition. Any different or additional terms in Buyer's purchase order or other Buyer documents are hereby objected to. Ridge reserves the right in its sole discretion to refuse orders.

1. PRICES: Unless a fixed price is quoted, the price at which this order is accepted is subject to adjustment to Ridge's price in effect at the time of order.

2. TERMS OF PAYMENT: Terms are stated on Ridge's invoice in U.S. currency. Ridge shall have the right, among other remedies, either to terminate this agreement or to suspend further performance under this and/or other agreements with the Buyer in the event Buyer fails to make any payment when due, which other agreements Buyer and Seller hereby amend accordingly, or Ridge otherwise deems itself insecure. Buyer shall be liable for all expenses, including attorneys' fees, relating to the collection of past due amounts. Should Buyer's financial responsibility become unsatisfactory to Ridge, cash payments or security satisfactory to Ridge may be required by Ridge for future deliveries and for the goods theretofore delivered. If such cash payment or security is not provided, in addition to Ridge's other rights and remedies, Ridge may discontinue deliveries.

3. SHIPMENT AND DELIVERY: Unless otherwise expressly provided, shipments are made F.O.B. Ridge's shipping point. Risk of loss or damage and responsibility shall pass from Ridge to Buyer upon delivery to and receipt by common carrier. Any claims for shortages or damages suffered in transit are the responsibility of Buyer and shall be submitted by the Buyer directly to the carrier. Shortages or damages must be acknowledged and signed for at the time of delivery. While Ridge will use all reasonable commercial efforts to maintain the delivery date(s) acknowledged or quoted by Ridge, all shipping dates are approximate and not guaranteed. Ridge reserves the right to make partial shipments. Ridge, at its option, shall not be bound to tender delivery of any Goods for which Buyer has not provided shipping instructions. If the shipment of the Goods is postponed or delayed by Buyer for any reason, Buyer agrees to reimburse Ridge for any and all handling and storage costs and other additional expenses resulting therefrom. All claims for shipping errors, lost shipments or any other discrepancies must be made within ninety (90) days or they will be disallowed and deemed waived.

4. Ridge WARRANTY: Ridge covers its products with a LIFETIME WARRANTY against defects in material or workmanship for the life of the tool. Pipe or drain cleaning tools, rods and cable, are not covered by this warranty and are considered expendable material. To take advantage of this warranty, the complete product must be delivered prepaid to RIDGE TOOL COMPANY or any RIDGE AUTHORIZED SERVICE CENTER. Pipe wrenches and other hand tools should be returned to

place of purchase. Obviously, failures due to misuse, abuse, or normal wear and tear are not covered by this warranty. NO OTHER WARRANTY, WRITTEN OR ORAL, APPLIES. No employee, agent, dealer, or other person is authorized to give any warranty on behalf of Ridge. Warranted products will be repaired or replaced at our option at no charge and returned via prepaid transportation. Such replacement or repair is the exclusive remedy available from Ridge. Ridge is not liable for damage of any sort, including without limitation incidental and consequential damages.

This warranty shall not apply to any Goods which:

- a. Have been repaired or altered outside Ridge's factory (or Authorized Service Center) or in any manner so as, in Ridge's judgment, to affect its serviceability or proper operation.
- b. Have been subjected by persons other than Ridge (or Authorized Service Center) to improper handling, operation, maintenance, repair or alteration.
- c. Have been subjected to misuse, negligence, improper installation or accident. Ridge's obligation under this warranty, and the Buyer's exclusive remedy for the breach thereof, shall be limited to, at Ridge's option, repair or replacement of any allegedly defective Goods or issuance of credit. Ridge requires the return of any allegedly defective Goods, transportation prepaid, before honoring any claim. All returned Goods are subject to inspection, and if examination does not disclose any defect covered by this warranty, replacement of such Goods or issuance of credit for same will not be approved.

THE FOREGOING CONSTITUTES RIDGE'S SOLE WARRANTY RESPONSIBILITY AND BUYER'S EXCLUSIVE REMEDY WHETHER SOUNDING IN TORT, CONTRACT, STRICT LIABILITY OR OTHERWISE, EXCEPT AS OTHERWISE EXPRESSLY SET FORTH IN THIS AGREEMENT. THERE ARE NO OTHER WARRANTIES, EXPRESS OR IMPLIED, WHETHER OF MERCHANTABILITY, FITNESS FOR A PARTICULAR PURPOSE, OR OTHERWISE. RIDGE SHALL NOT BE LIABLE FOR ANY SPECIAL, INDIRECT, INCIDENTAL OR CONSEQUENTIAL DAMAGES OF ANY CHARACTER IN CONNECTION WITH THE SALE, RESALE OR USE OF THE GOODS.

This warranty extends only to persons or organizations who purchase the Goods from Ridge for resale.

5. LIMITATION OF REMEDY AND LIABILITY: THE SOLE AND EXCLUSIVE REMEDY FOR BREACH OF ANY WARRANTY HEREUNDER SHALL BE LIMITED TO REPAIR, CORRECTION, REPLACEMENT OR CREDIT UNDER SECTION 4.

RIDGE SHALL NOT BE LIABLE FOR DAMAGES CAUSED BY DELAY IN PERFORMANCE, AND IN NO EVENT, REGARDLESS OF THE FORM OF THE CLAIM OR CAUSE OF ACTION (WHETHER BASED IN CONTRACT, INFRINGEMENT, NEGLIGENCE, STRICT LIABILITY, OTHER TORT OR OTHERWISE), SHALL RIDGE'S LIABILITY TO BUYER AND/OR ITS CUSTOMERS EXCEED THE PRICE PAID BY BUYER FOR THE SPECIFIC GOODS GIVING RISE TO THE CLAIM OR CAUSE OF ACTION, AND BUYER SHALL INDEMNIFY RIDGE FOR ANY DAMAGES IN EXCESS THEREOF. BUYER AGREES THAT IN NO EVENT SHALL RIDGE'S LIABILITY TO BUYER AND/OR ITS CUSTOMERS INCLUDE INCIDENTAL, CONSEQUENTIAL OR PUNITIVE DAMAGES, WHICH ARE WAIVED BY BUYER AND AS TO WHICH BUYER SHALL INDEMNIFY RIDGE. The term "consequential damages" shall include, but not be limited to, loss of

anticipated profits, business interruption, loss of use of revenue, cost of capital or loss of or damage to property or equipment, or loss of reputation. Further, Buyer shall indemnify and hold Ridge harmless from any liability to Buyer, Buyer's employees, workers, contractors or any other persons arising out of Buyer's, or any other persons' use of the Goods. All instructions and warnings supplied by Ridge will be passed on to those persons who use the Goods. Ridge's Goods are to be used in their recommended applications and all warning labels adhered to the Goods by Ridge shall be left intact.

6. EXCUSE OF PERFORMANCE (FORCE MAJEURE): Ridge shall not be liable for delays in performance or for non-performance due to acts of God; acts of Buyer; war; fire; flood; weather; sabotage; strikes, labor disputes, civil disturbances or riots; governmental requests, restrictions, allocations, laws, regulations, orders or actions; unavailability of or delays in transportation; default of suppliers; or unforeseen circumstances or events beyond Ridge's reasonable control. Deliveries or other performance may be suspended for an appropriate period of time or cancelled by Ridge upon notice to Buyer in the event of any of the foregoing, but the balance of this agreement shall otherwise remain unaffected.

If Ridge determines that its ability to supply the total demand for the Goods, or to obtain material used directly or indirectly in the manufacture of the Goods, is hindered, limited or made impracticable due to causes set forth herein, Ridge may allocate its available supply of the Goods or such material (without obligation to acquire other supplies of any such Goods or materials) among itself and its purchasers on such basis as Ridge determines to be equitable without liability for any failure of performance which may result therefrom.

7. CHANGES: Ridge reserves the right to change designs and specifications for standard Goods without prior notice to Buyer, but not with respect to custom Goods being made for Buyer. Ridge shall have no obligation to install or make such change in any Goods manufactured prior to the date of such change.

8. ASSIGNMENT: Buyer shall not assign its rights or delegate its duties hereunder or any interest herein without the prior written consent of Ridge, and any such assignment, without such consent, shall be void.

9. INSTALLATION: Buyer shall be responsible for receiving, inspecting, testing, storing, installing, starting up and maintaining all Goods.

10. INSPECTION/TESTING: Buyer, at its expense, agrees that it will promptly inspect the Goods upon receipt thereof, and in no event later than thirty (30) days from the date of receipt of the Goods. Buyer shall deliver to Ridge within fifteen (15) days of inspection, but in no event later than forty-five (45) days from the date of receipt of the Goods, written notice of any and all deficiencies, defects, variations from specifications or complaints of any kind with respect to the quantity, quality, condition, shipment, performance, price or appearance of the Goods so received by Buyer. In the event no such written notice is received by Ridge, Buyer shall be deemed conclusively to have inspected and accepted all such Goods unconditionally and to have waived any and all rights and claims, including without limitation any right to reject the Goods or to claim damages in respect thereof. Buyer may not return Goods without first advising Ridge of the reasons therefore, obtaining from Ridge a material authorization number and observing such instructions as Ridge may give in authorizing such return.

11. SERVICES: If this agreement requires Ridge to perform or provide any services, Ridge (including without limitation its successors, assigns, agents or any person or entity acting at Ridge's direction) shall not be responsible for any damages, claims, liabilities or expenses of any nature arising out of such services.

12. U.S. EXPORT CONTROL LAWS: All Goods sold to Buyer by Ridge hereunder are subject to U.S. Export Control Laws. Buyer hereby agrees not to re-sell or divert any goods contrary to such laws.

13. SELLER/CONTRACTOR: shall comply with all applicable federal, state or local laws, rules, regulations, or orders. Seller/Contractor shall comply with Executive Order 11246, as amended by the Executive Order 11375, and the applicable provisions of the Office of Federal Contract Compliance Programs (OFCCP), 41 CFR Part 60, which are incorporated herein by this reference.

14. MISCELLANEOUS: These terms and conditions supersede all other communications, negotiations and prior oral or written statements regarding the subject matter hereof. No change, modification, rescission, discharge, abandonment, or waiver of these terms and conditions shall be binding upon Ridge unless made in writing and signed on its behalf by its duly authorized representative. No conditions, usage or trade, course of dealing or performance, understanding or agreement purporting to modify, vary, explain, or supplement these terms and conditions shall be binding unless hereafter made in writing and signed by Seller. No modification shall be effected by Ridge's receipt or acceptance of Buyer's purchase orders, shipping instruction forms, or other documentation containing terms at variance with or in addition to those set forth herein, all of which are objected to by Ridge. No waiver by Ridge with respect to any breach or default of any right or remedy and no course of dealing, shall be deemed to constitute a continuing waiver of any other breach or default of any other right or remedy, unless such waiver be expressed in writing and signed by Ridge. All typographical or clerical errors made by Ridge in any quotation, acknowledgment or publication are subject to correction.

The validity, performance, and all other matters relating to the interpretation and effect of this agreement shall be governed by the laws of the state of Ohio without regard to its conflict of law principles. Buyer and Ridge agree that the proper venue for all actions arising in connection herewith shall be only in Ohio and the parties agree to submit to such jurisdiction. No action, regardless of form, arising out of transactions relating to this contract, may be brought by either party more than two (2) years after the cause of action has accrued. Further, the United Nations Convention on the International Sale of Goods (1980) (as amended from time to time) shall not apply to this Purchase Order or any transactions relating thereto.

RIDGID

BUILT FOR THOSE WHO KNOW.™

©2006, 2016, RIDGID, Inc. The Emerson logo and RIDGID logo are registered trademarks of Emerson Electric Co. or RIDGID, Inc. in the U.S. and other countries. All other trademarks belong to their respective holders.



EMERSON

999-997-517.10 V8.5
Printed in U.S.A. 1116-45K