

THIS DRAWING AND THE INFORMATION HEREON ARE OUR PROPERTY AND MAY BE USED BY OTHERS ONLY AS AUTHORIZED BY STAHLIN ENCLOSURES, DIVISION OF ROBROY INDUSTRIES. ALL RIGHTS RESERVED UNDER THE COPYRIGHT LAWS.

SPECIAL REQUIREMENTS

- CNC:**
 1. CONTACT SUPERVISOR FOR FIRST PART INSPECTION
 2. CONTACT ENGINEERING FOR FIRST RUN INSPECTION
- ASSEMBLY:**
 1. USE J2420 BOX FIXTURE TO DRILL KEEPER HOLES

NEMA 250: TYPE 1, 3, 3R, 4, 4X, 12, 13 IEC 60529: IP66 COLOR: GLACIER GRAY (WPR3013) COLOR STANDARD: PANTONE 428 C		STANDARD P/N: J24203PT CUSTOMER DWG:	ALL DIMENSIONS ARE IN INCHES UNLESS OTHERWISE SPECIFIED	TOLERANCES UNLESS SPECIFIED _XX ± 0.03 _XXX ± 0.010																																										
MATERIAL: FIBERGLASS REINFORCED POLYESTER (FRP)		 STAHLIN A DIVISION OF ROBROY INDUSTRIES	Stahlin Non-Metallic Enclosures 500 Maple Street Belding, Michigan 48809 Phone: 616-794-0700 Fax: 616-749-3378																																											
<table border="1"> <thead> <tr> <th>REV</th> <th>DESCRIPTION</th> <th>DATE</th> <th>ENG</th> </tr> </thead> <tbody> <tr><td>-</td><td>-</td><td>-</td><td>-</td></tr> <tr><td>-</td><td>-</td><td>-</td><td>-</td></tr> <tr><td>-</td><td>-</td><td>-</td><td>-</td></tr> <tr><td>-</td><td>-</td><td>-</td><td>-</td></tr> <tr><td>-</td><td>-</td><td>-</td><td>-</td></tr> <tr><td>-</td><td>-</td><td>-</td><td>-</td></tr> </tbody> </table>			REV	DESCRIPTION	DATE	ENG	-	-	-	-	-	-	-	-	-	-	-	-	-	-	-	-	-	-	-	-	-	-	-	-	<table border="1"> <tr> <td>DRAWN BY</td> <td>DATE</td> <td>CUSTOMER</td> <td>DWG</td> </tr> <tr> <td>DRH</td> <td>12/11/2013</td> <td></td> <td>J24203PT</td> </tr> <tr> <td>SCALE</td> <td>DO NOT SCALE</td> <td>DESCRIPTION</td> <td>PART NUMBER</td> </tr> <tr> <td></td> <td></td> <td>STANDARD ENCLOSURE</td> <td>J24203PT</td> </tr> </table>	DRAWN BY	DATE	CUSTOMER	DWG	DRH	12/11/2013		J24203PT	SCALE	DO NOT SCALE	DESCRIPTION	PART NUMBER			STANDARD ENCLOSURE
REV	DESCRIPTION	DATE	ENG																																											
-	-	-	-																																											
-	-	-	-																																											
-	-	-	-																																											
-	-	-	-																																											
-	-	-	-																																											
-	-	-	-																																											
DRAWN BY	DATE	CUSTOMER	DWG																																											
DRH	12/11/2013		J24203PT																																											
SCALE	DO NOT SCALE	DESCRIPTION	PART NUMBER																																											
		STANDARD ENCLOSURE	J24203PT																																											

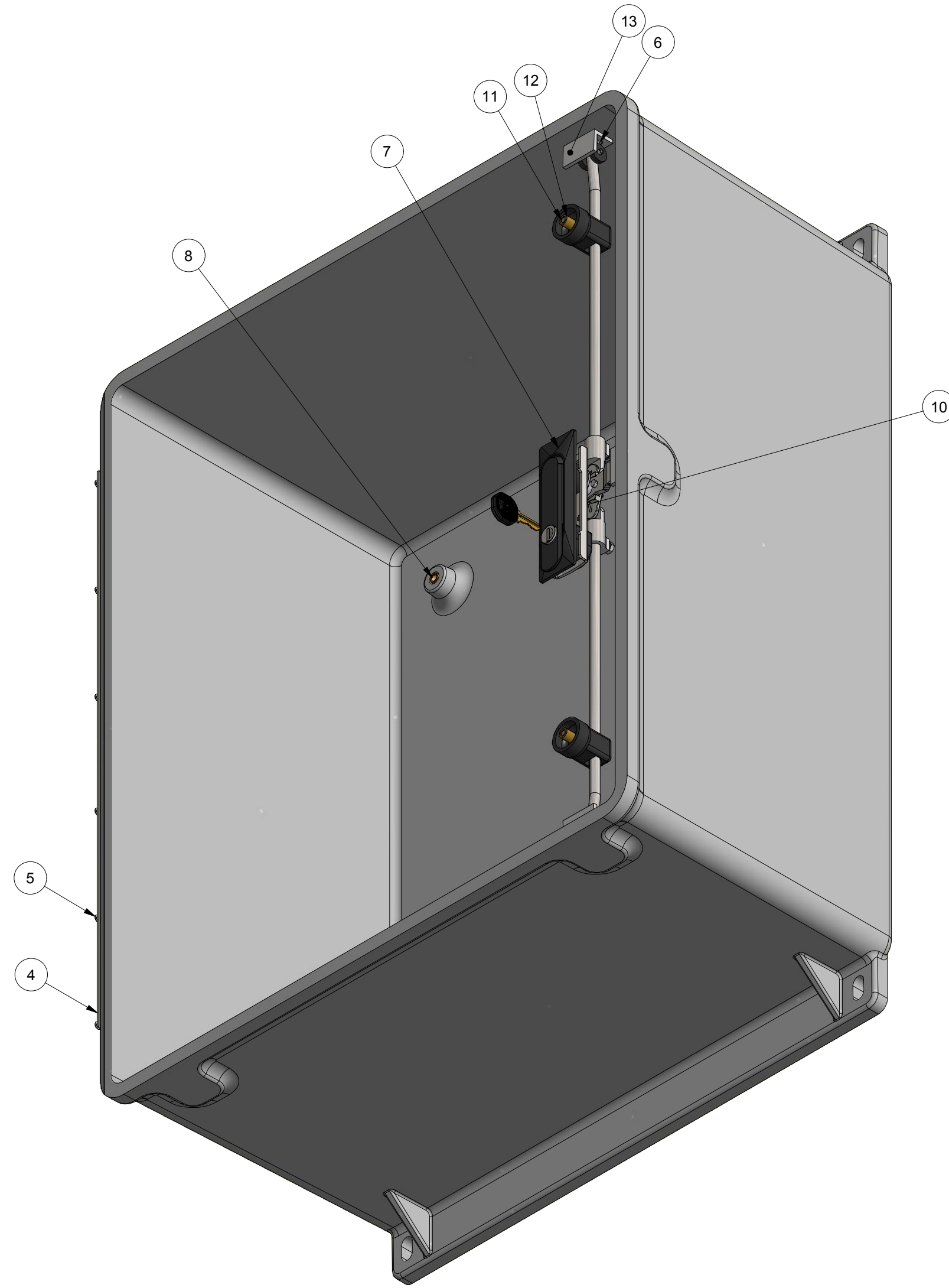
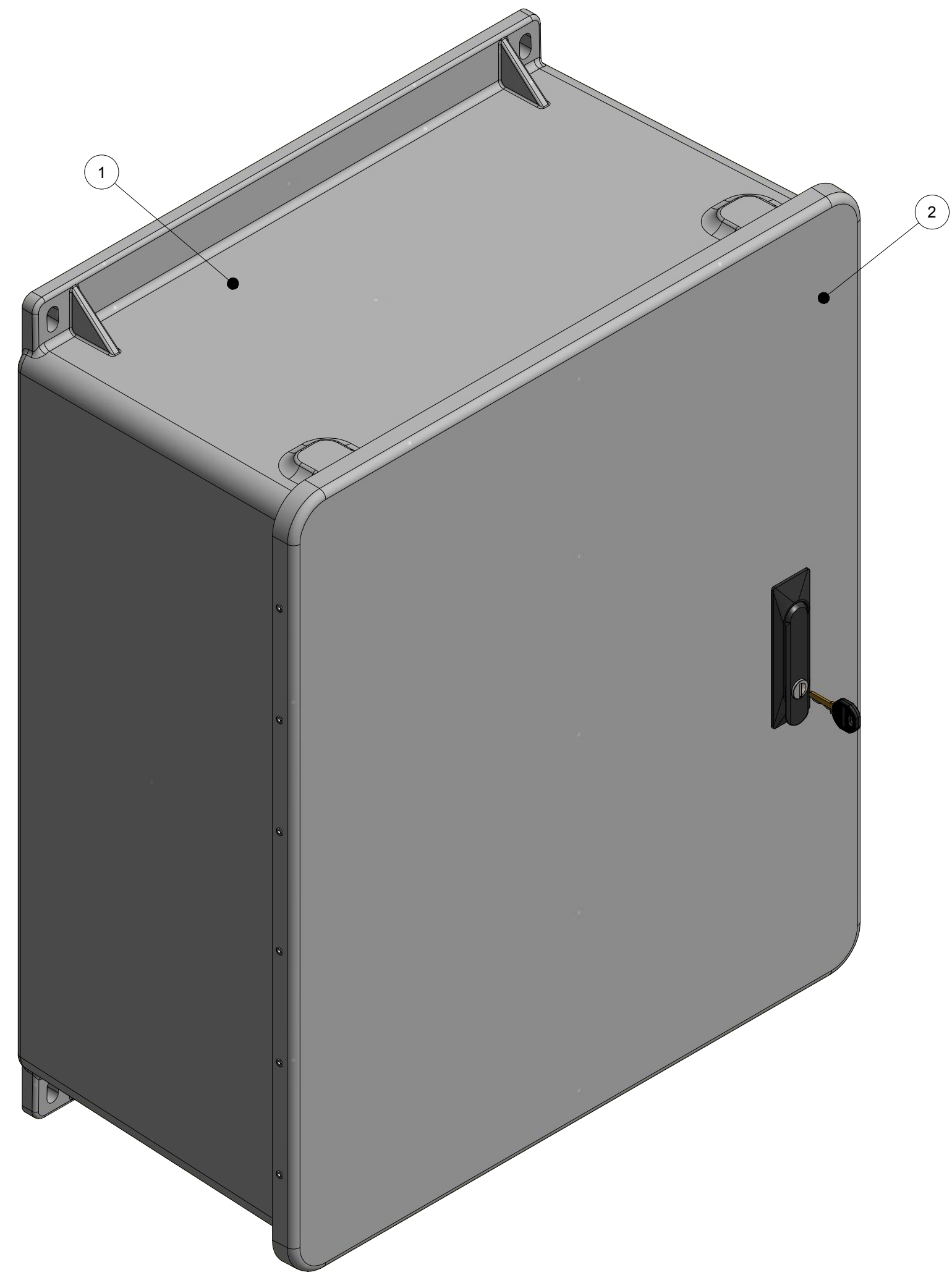

PARTS LIST			
ITEM	QTY	PART NUMBER	DESCRIPTION
1	1	WP2420HBOX	J2420 MOLDED HINGE BOX
2	1	WP2420HCVR	J2420 MOLDED HINGE CVR
3	1	RMGAS_WP2420HCVR	WP2420HU3PT GASKET
4	1	RMHING19-1/2	19.5" HINGE
5	12	RMRIV44	RIVET
6	6	RMRIV46	RIVET
7	1	RMEMK1150U102	3PT HANDLE KIT
8	4	RMINSOD700154500	1/4-20 x 5/16 DODGE EXPANSION INSERT
9	1	N/A	J24203PT LABEL
10	2	RMSC818X1/2PHPS	8-18 x 1/2 THREAD-CUTTING SCREW FOR SOFT PLASTICS
11	2	RMSTUDM6X20MM	M6 x 20 mm STEEL STUD
12	2	RMINSM60X364P	M60 x 0.364" BRASS INSERT
13	2	WP1/8X3/4X3/4KEEPE	1/8 x 3/4 x 3/4 ANGLE

THIS DRAWING AND THE INFORMATION HEREON ARE OUR PROPERTY AND MAY BE USED BY OTHERS ONLY AS AUTHORIZED BY STAHLIN ENCLOSURES, DIVISION OF ROBOBY INDUSTRIES. ALL RIGHTS RESERVED UNDER THE COPYRIGHT LAWS.

SPECIAL REQUIREMENTS

- CNC:**
 1. CONTACT SUPERVISOR FOR FIRST PART INSPECTION
 2. CONTACT ENGINEERING FOR FIRST RUN INSPECTION

- ASSEMBLY:**
 1. USE J2420 BOX FIXTURE TO DRILL KEEPER HOLES

NEMA 250: TYPE 1, 3, 3R, 4, 4X, 12, 13
 IEC 60529: IP66
 COLOR: GLACIER GRAY (WPR3013)
 COLOR STANDARD: PANTONE 428 C

STANDARD P/N: J24203PT
 CUSTOMER DWG:

ALL DIMENSIONS ARE IN INCHES UNLESS OTHERWISE SPECIFIED
 TOLERANCES UNLESS SPECIFIED .XX .XXX
 ± 0.03 ± 0.010

MATERIAL: FIBERGLASS REINFORCED POLYESTER (FRP)

STAHLIN
 A DIVISION OF ROBOBY INDUSTRIES
 Stahlin Non-Metallic Enclosures
 500 Maple Street
 Belding, Michigan 48809
 Phone: 616-794-0700
 Fax: 616-749-3378

DRAWN BY	DATE	CUSTOMER	DWG
DRH	12/11/2013		J24203PT
SCALE	DESCRIPTION	PART NUMBER	
DO NOT SCALE	STANDARD ENCLOSURE	J24203PT	