

THIS DRAWING AND THE INFORMATION
HEREON ARE OUR PROPERTY AND MAY
BE USED BY OTHERS ONLY AS
AUTHORIZED BY STAHLIN ENCLOSURES,
DIVISION OF ROBROY INDUSTRIES
ALL RIGHTS RESERVED
UNDER THE COPYRIGHT LAWS

SPECIAL REQUIREMENTS

NEMA 250: TYPE 1, 3, 3R, 4, 4X, 12, 13 IEC 60529: IP66 COLOR: GLACIER GRAY (WPR3013) COLOR STANDARD: PANTONE 428 C		STANDARD P/N: J2020HPL CUSTOMER DWG:	ALL DIMENSIONS ARE IN INCHES UNLESS OTHERWISE SPECIFIED	TOLERANCES UNLESS SPECIFIED	.XX ± 0.03 .XXX ± 0.010
MATERIAL: FIBERGLASS REINFORCED POLYESTER (FRP)					
REVISION HISTORY					
REV	DESCRIPTION	DATE	ENG		
-	-	-	-		
-	-	-	-		
-	-	-	-		
-	-	-	-		
-	-	-	-		
DRAWN BY: DRH		DATE: 12/03/2013	CUSTOMER:		DWG: J2020HPL
SCALE: DO NOT SCALE		DESCRIPTION: STANDARD ENCLOSURE	PART NUMBER: J2020HPL		

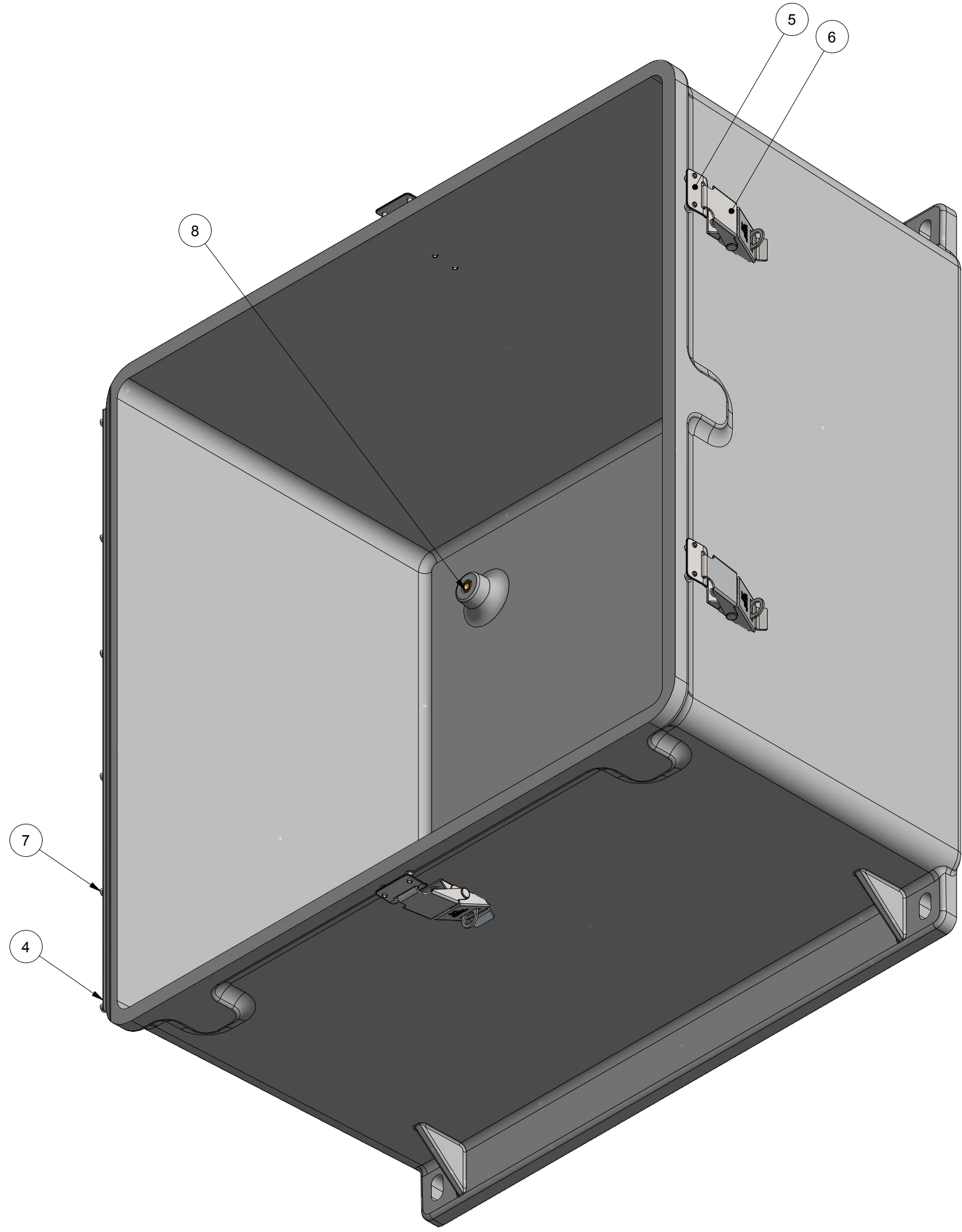

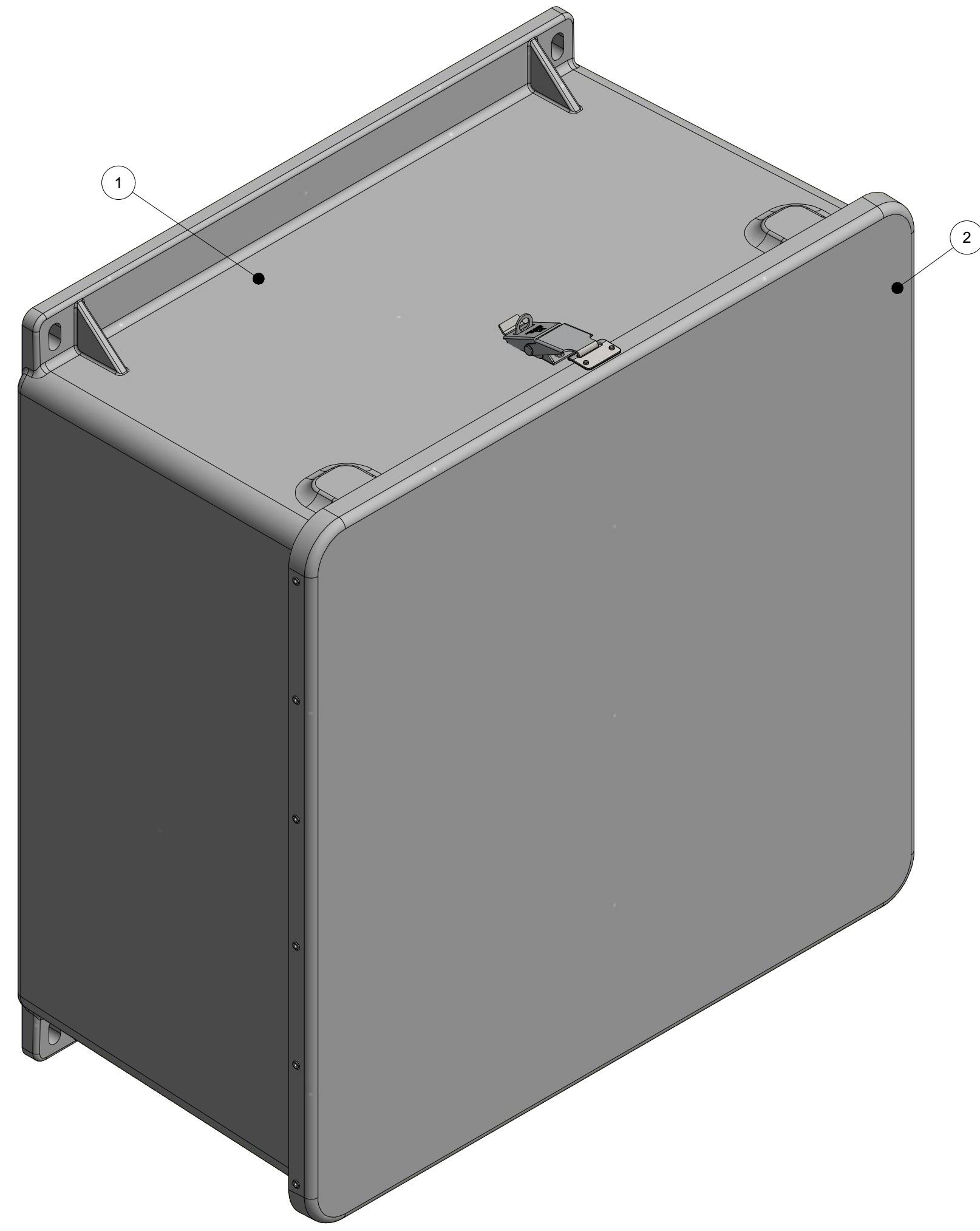

PARTS LIST			
ITEM	QTY	PART NUMBER	DESCRIPTION
1	1	WP2020H&LBOX	J2020 MOLDED H&L BOX
2	1	WP2020H&LCVR	J2020 MOLDED H&L CVR
3	1	RMGAS_WP2020H&LCVR	WP2020HLU GASKET
4	1	RMHING19-1/2	19.5" HINGE
5	4	RMKEEPSSL	HPL KEEPER
6	4	RMLATSSL	HPL LATCH
7	28	RMRIV44	RIVET
8	4	RMINSOD700154500	1/4-20 x 5/16 DODGE EXPANSION INSERT
9	1	N/A	J2020HPL LABEL

THIS DRAWING AND THE INFORMATION HEREON ARE OUR PROPERTY AND MAY BE USED BY OTHERS ONLY AS AUTHORIZED BY STAHLIN ENCLOSURES, DIVISION OF ROBROY INDUSTRIES. ALL RIGHTS RESERVED UNDER THE COPYRIGHT LAWS.

SPECIAL REQUIREMENTS

NEMA 250: TYPE 1, 3, 3R, 4, 4X, 12, 13 IEC 60529: IP66 COLOR: GLACIER GRAY (WPR3013) COLOR STANDARD: PANTONE 428 C		STANDARD P/N: J2020HPL CUSTOMER DWG:	ALL DIMENSIONS ARE IN INCHES UNLESS OTHERWISE SPECIFIED	TOLERANCES UNLESS SPECIFIED .XX ± 0.03 .XXX ± 0.010
MATERIAL: FIBERGLASS REINFORCED POLYESTER (FRP)			 STAHLIN A DIVISION OF ROBROY INDUSTRIES <i>Stahlin Non-Metallic Enclosures</i> 500 Maple Street Belding, Michigan 48809 Phone: 616-794-0700 Fax: 616-749-3378	
DRAWN BY: DRH	DATE: 12/03/2013	CUSTOMER:	DWG: J2020HPL	
SCALE: DO NOT SCALE	DESCRIPTION: STANDARD ENCLOSURE	PART NUMBER: J2020HPL		