

Parker Worldwide

Europe, Middle East, Africa

AE – United Arab Emirates, Dubai
Tel: +971 4 8127100
parker.me@parker.com

AT – Austria, St. Florian
Tel: +43 (0)7224 66201
parker.austria@parker.com

AZ – Azerbaijan, Baku
Tel: +994 50 2233 458
parker.azerbaijan@parker.com

BE/NL/LU – Benelux, Hendrik Ido Ambacht
Tel: +31 (0)541 585 000
parker.nl@parker.com

BG – Bulgaria, Sofia
Tel: +359 2 980 1344
parker.bulgaria@parker.com

BY – Belarus, Minsk
Tel: +48 (0)22 573 24 00
parker.poland@parker.com

CH – Switzerland, Etoy
Tel: +41 (0)21 821 87 00
parker.switzerland@parker.com

CZ – Czech Republic, Klecany
Tel: +420 284 083 111
parker.czechrepublic@parker.com

DE – Germany, Kaarst
Tel: +49 (0)2131 4016 0
parker.germany@parker.com

DK – Denmark, Ballerup
Tel: +45 43 56 04 00
parker.denmark@parker.com

ES – Spain, Madrid
Tel: +34 902 330 001
parker.spain@parker.com

FI – Finland, Vantaa
Tel: +358 (0)20 753 2500
parker.finland@parker.com

FR – France, Contamine s/Arve
Tel: +33 (0)4 50 25 80 25
parker.france@parker.com

GR – Greece, Piraeus
Tel: +30 210 933 6450
parker.greece@parker.com

HU – Hungary, Budaörs
Tel: +36 23 885 470
parker.hungary@parker.com

IE – Ireland, Dublin
Tel: +353 (0)1 466 6370
parker.ireland@parker.com

IL – Israel
Tel: +39 02 45 19 21
parker.israel@parker.com

IT – Italy, Corsico (MI)
Tel: +39 02 45 19 21
parker.italy@parker.com

KZ – Kazakhstan, Almaty
Tel: +7 7273 561 000
parker.easteurope@parker.com

NO – Norway, Asker
Tel: +47 66 75 34 00
parker.norway@parker.com

PL – Poland, Warsaw
Tel: +48 (0)22 573 24 00
parker.poland@parker.com

PT – Portugal
Tel: +351 22 999 7360
parker.portugal@parker.com

RO – Romania, Bucharest
Tel: +40 21 252 1382
parker.romania@parker.com

RU – Russia, Moscow
Tel: +7 495 645-2156
parker.russia@parker.com

SE – Sweden, Spånga
Tel: +46 (0)8 59 79 50 00
parker.sweden@parker.com

SK – Slovakia, Banská Bystrica
Tel: +421 484 162 252
parker.slovakia@parker.com

SL – Slovenia, Novo Mesto
Tel: +386 7 337 6650
parker.slovenia@parker.com

TR – Turkey, Istanbul
Tel: +90 216 4997081
parker.turkey@parker.com

UA – Ukraine, Kiev
Tel: +48 (0)22 573 24 00
parker.poland@parker.com

UK – United Kingdom, Warwick
Tel: +44 (0)1926 317 878
parker.uk@parker.com

ZA – South Africa, Kempton Park
Tel: +27 (0)11 961 0700
parker.southafrica@parker.com

North America

CA – Canada, Milton, Ontario
Tel: +1 905 693 3000

US – USA, Cleveland
Tel: +1 216 896 3000

Asia Pacific

AU – Australia, Castle Hill
Tel: +61 (0)2-9634 7777

CN – China, Shanghai
Tel: +86 21 2899 5000

HK – Hong Kong
Tel: +852 2428 8008

IN – India, Mumbai
Tel: +91 22 6513 7081-85

JP – Japan, Tokyo
Tel: +81 (0)3 6408 3901

KR – South Korea, Seoul
Tel: +82 2 559 0400

MY – Malaysia, Shah Alam
Tel: +60 3 7849 0800

NZ – New Zealand, Mt Wellington
Tel: +64 9 574 1744

SG – Singapore
Tel: +65 6887 6300

TH – Thailand, Bangkok
Tel: +662 186 7000

TW – Taiwan, Taipei
Tel: +886 2 2298 8987

South America

AR – Argentina, Buenos Aires
Tel: +54 3327 44 4129

BR – Brazil, Sao Jose dos Campos
Tel: +55 800 727 5374

CL – Chile, Santiago
Tel: +56 2 623 1216

MX – Mexico, Toluca
Tel: +52 72 2275 4200

Industrial Tube Fittings Europe

Technical Handbook



Industrial Tube Fittings Europe

Technical handbook/Catalogue 4100/UK



EMEA Product Information Centre

Free phone: 00 800 27 27 5374

(from AT, BE, CH, CZ, DE, DK, EE, ES, FI, FR, IE, IL, IS, IT, LU, MT, NL, NO, PL, PT, RU, SE, SK, UK, ZA)

US Product Information Centre

Toll-free number: 1-800-27 27 537

www.parker.com

Your local authorized Parker distributor



ENGINEERING YOUR SUCCESS.

Parker's Motion & Control Technologies

At Parker, we're guided by a relentless drive to help our customers become more productive and achieve higher levels of profitability by engineering the best systems for their requirements. It means looking at customer applications from many angles to find new ways to create value. Whatever the motion and control technology need, Parker has the experience, breadth of product and global reach to consistently deliver. No company knows more about motion and control technology than Parker.

For further info call
00800 27 27 5374



Aerospace

Key Markets

Aftermarket services
Commercial transports
Engines
General & business aviation
Helicopters
Launch vehicles
Military aircraft
Missiles
Power generation
Regional transports
Unmanned aerial vehicles

Key Products

Control systems & actuation products
Engine systems & components
Fluid conveyance systems & components
Fluid metering, delivery & atomization devices
Fuel systems & components
Fuel tank inerting systems
Hydraulic systems & components
Thermal management
Wheels & brakes



Climate Control

Key Markets

Agriculture
Air conditioning
Construction Machinery
Food & beverage
Industrial machinery
Life sciences
Oil & gas
Precision cooling
Process
Refrigeration
Transportation

Key Products

Accumulators
Advanced actuators
CO₂ controls
Electronic controllers
Filter driers
Hand shut-off valves
Heat exchangers
Hose & fittings
Pressure regulating valves
Refrigerant distributors
Safety relief valves
Smart pumps
Thermostatic expansion valves



Hydraulics

Key Markets

Aerial lift
Agriculture
Alternative energy
Construction machinery
Forestry
Industrial machinery
Machine tools
Marine
Material handling
Mining
Oil & gas
Power generation
Refuse vehicles
Renewable energy
Truck hydraulics
Turf equipment

Key Products

Accumulators
Cartridge valves
Electrohydraulic actuators
Human machine interfaces
Hybrid drives
Hydraulic cylinders
Hydraulic motors & pumps
Hydraulic systems
Hydraulic valves & controls
Hydrostatic steering
Integrated hydraulic circuits
Power take-offs
Power units
Rotary actuators
Sensors



Pneumatics

Key Markets

Aerospace
Conveyor & material handling
Factory automation
Life science & medical
Machine tools
Packaging machinery
Transportation & automotive

Key Products

Air preparation
Brass fittings & valves
Manifolds
Pneumatic accessories
Pneumatic actuators & grippers
Pneumatic valves & controls
Quick disconnects
Rotary actuators
Rubber & thermoplastic hose & couplings
Structural extrusions
Thermoplastic tubing & fittings
Vacuum generators, cups & sensors



Electromechanical

Key Markets

Aerospace
Factory automation
Life science & medical
Machine tools
Packaging machinery
Paper machinery
Plastics machinery & converting
Primary metals
Semiconductor & electronics
Textile
Wire & cable

Key Products

AC/DC drives & systems
Electric actuators, gantry robots & slides
Electrohydraulic actuation systems
Electromechanical actuation systems
Human machine interface
Linear motors
Stepper motors, servo motors, drives & controls
Structural extrusions



Filtration

Key Markets

Aerospace
Food & beverage
Industrial plant & equipment
Life sciences
Marine
Mobile equipment
Oil & gas
Power generation & renewable energy
Process
Transportation
Water Purification

Key Products

Analytical gas generators
Compressed air filters & driers
Engine air, coolant, fuel & oil filtration systems
Fluid condition monitoring systems
Hydraulic & lubrication filters
Hydrogen, nitrogen & zero air generators
Instrumentation filters
Membrane & fiber filters
Microfiltration
Sterile air filtration
Water desalination & purification filters & systems



Fluid & Gas Handling

Key Markets

Aerial lift
Agriculture
Bulk chemical handling
Construction machinery
Food & beverage
Fuel & gas delivery
Industrial machinery
Life sciences
Marine
Mining
Mobile
Oil & gas
Renewable energy
Solenoid valves
Transportation

Key Products

Check valves
Connectors for low pressure fluid conveyance
Deep sea umbilicals
Diagnostic equipment
Hose couplings
Industrial hose
Mooring systems & power cables
PTFE hose & tubing
Quick couplings
Rubber & thermoplastic hose
Tube fittings & adapters
Tubing & plastic fittings



Process Control

Key Markets

Alternative fuels
Biopharmaceuticals
Chemical & refining
Food & beverage
Marine & shipbuilding
Medical & dental
Microelectronics
Nuclear Power
Offshore oil exploration
Oil & gas
Pharmaceuticals
Power generation
Pulp & paper
Steel
Water/wastewater

Key Products

Analytical Instruments
Analytical sample conditioning products & systems
Chemical injection fittings & valves
Fluoropolymer chemical delivery fittings, valves & pumps
High purity gas delivery fittings, valves, regulators & digital flow controllers
Industrial mass flow meters/controllers
Permanent no-weld tube fittings
Precision industrial regulators & flow controllers
Process control double block & bleeds
Process control fittings, valves, regulators & manifold valves



Sealing & Shielding

Key Markets

Aerospace
Chemical processing
Consumer
Fluid power
General industrial
Information technology
Life sciences
Microelectronics
Military
Oil & gas
Power generation
Renewable energy

Key Products

Dynamic seals
Elastomeric o-rings
Electro-medical instrument design & assembly
EMI shielding
Extruded & precision-cut, fabricated elastomeric seals
High temperature metal seals
Homogeneous & inserted elastomeric shapes
Medical device fabrication & assembly
Metal & plastic retained composite seals
Shielded optical windows
Silicone tubing & extrusions
Thermal management
Vibration dampening



ENGINEERING YOUR SUCCESS.

Tube fittings catalogue/Table of contents

Introduction	page 2
Detailed table of contents	page 14
Function of fittings.....	A
Systematic fitting selection	B
Performance data.....	C
Dimensioning.....	D
Tube assembly	E
Fitting assembly	F
Trouble shooting guide.....	G
Tooling	H
DIN fittings.....	I
O-Lok®	J
Triple-Lok®	K
Ferulok®	L
Weld fittings.....	M
High Pressure Hydraulic Flanges	N
Adapters	O
Valves	P
Rotary fittings	Q
Parker SensoControl® Diagnostic equipment.....	R
Tubes.....	S
Tube clamps	T
Custom Products	U
Alphanumerical index.....	V

Parker Hannifin – Professionals in System Solutions



Parker Hannifin is the world's leading manufacturer of motion and control technologies. The company develops and designs systems and precision solutions for mobile and industrial applications as well as the aerospace industry. Parker Hannifin employs around 56,000 people in 50 countries.

The Company's main business objective is to help customers achieve maximum productivity for their applications with the support of professional Parker engineers. This is achieved through innovative, top quality and reliable proprietary products. These can be delivered quickly thanks to a worldwide sales network. Parker is the consummate provider of customized system solutions.

Video



The strength of Parker

Under the umbrella of the Fluid Connectors Group Europe, Parker Hannifin brings together the connector technology of the brands Ermeto, Legris Transair, Legris Connectic, Legris Autoline, Polyflex, ITR, Rectus, and Tema. Whether it be tube fittings, hose fittings, or hoses, Parker offers the most comprehensive range available from a single supplier.

As part of the Fluid Connectors Group Europe, High Pressure Connectors Europe (HPCE) is one of the largest businesses in Parker. The foundation stone for enduring business success was laid with the development of the Ermeto cutting ring. Nowadays, flanges, valves, tubing, measuring systems, and tube forming and pre-assembly machines, besides the classic DIN and SAE fittings, are manufactured in several locations.



Whether standard parts or application-specific special developments, the Parker product programme offers an appropriate solution for every customer requirement.

Always new product ideas

Innovations secure the future

Without new product ideas there would be no progress: Parker has an efficient product development program in the form of the Winovation Program. From the initial idea through to market readiness, every stage is checked to

exact criteria before it moves on to the next project phase. This is how the customers are guaranteed beneficial products ready for series production, that work reliably from the first use and over the long term.

EO-2

For over 25 years, EO-2 fitting series have stood for leak-free performance with elastomer seals, long service lives thanks to above-average corrosion resistance. Significant cost and time savings thanks to higher rated pressures.

www.parker.com/eo-2



Complete Piping Solutions

Complete Piping Solutions is the high-quality complete solution for weld-free connection technology for hydraulic systems. From advising to designing and pre-assembly to delivery and installation – all with outstanding quality and reliability. Major time and cost savings.

Video



The Parflange F37 product range is a personnel and environmentally-friendly technology. In comparison to conventional welding, production times are reduced by more than half.

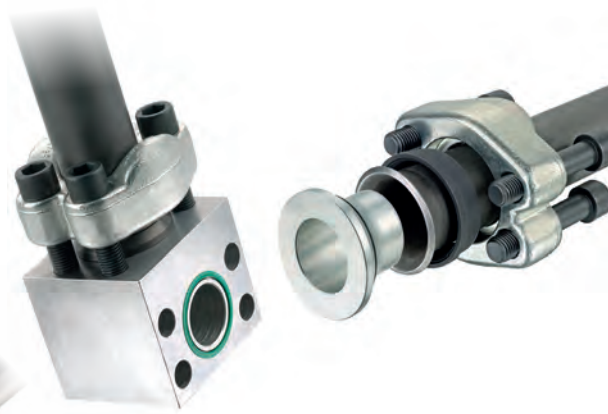

Parflange® F37

For tube and pipeline connections. Outstanding seal, high mechanical strength. For tubes from 16 to 165 mm exterior diameter, wall thickness up to 9 mm and pressures up to 420 bar.

High Performance flange

vibration-resistant. Resistant to tear-out. For mobile hydraulic and industrial applications, working pressures up to 420 bar and tube diameters from 25-88 mm. Wall thickness up to 14 mm. Flange hole pattern in accordance with ISO 6162-1, ISO 6162-2 and ISO 6154.

Video



Serviceman Plus

Mobile measurement technology for everyday use. "Plug & play" with automatic sensor recognition. Simply insert and measure. New memory concept with Nano USB stick. USB-PC interface for convenient analysis and documentation of measurements via the SensoWin software.

Serviceman Plus – Benefits in hand The Serviceman Plus is a highly robust, mobile, and easy to operate measurement device for many measurement tasks in mobile hydraulic or stationary hydraulic systems.

www.parker.com/hpce

Video

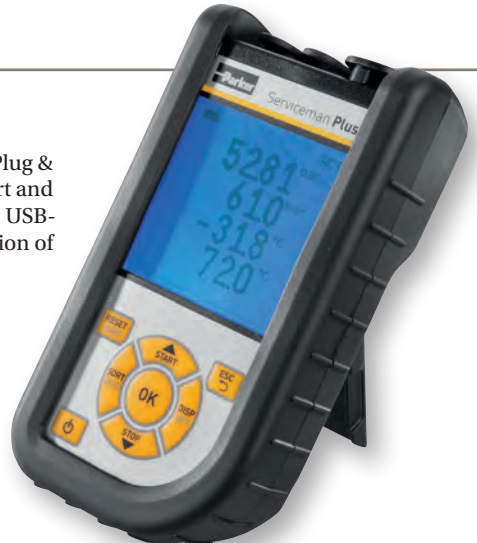

Markets make the brand

The right concepts for every need

Partnership and collaboration with customers is what makes our product policy at Parker unique. With a refined feel for the needs of users and the requirements of different markets, Parker engineers develop the solutions they need.

The result is a range of products that bear the hallmarks of consistent high quality in materials and production, and offer reliable function at a world-class level.

www.parker.com/hpce

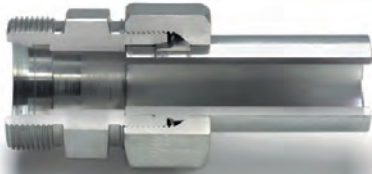

EO-PSR



The world's most widespread high-pressure fittings system: Highest pressure resistance and extreme corrosion resistance thanks to Cr(VI)-free surfaces. Perceptibly reduced tightening torques. Considerable assembly advantages.



The positively locking high-pressure form connector.

Special features - classical EO-2 sealing ring and cold-formed tubing. Impressively superior mechanical strength and maximum pull-out resistance. For 800 bar (PN) in S Series and up to 500 bar (PN) in L Series.

EO2-Form

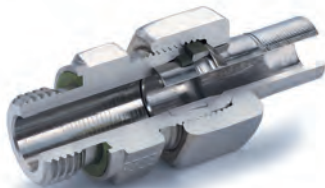

The tried and tested Dry Technology concept.

Has a large volume elastomeric seal on the tube side and Cr(VI)-free surfaces, which are very corrosion resistant. Suitable for 800 bar (PN) in S Series and up to 500 bar (PN) in the L Series.

E0-2



O-Lok®



Fittings series with face-side O-ring seal.

Suitable for a wide range of tube wall thicknesses. Applicable to metric and inch tubes and hose connections.



37° flare system.

The most widely used fittings system for inch tubes. For pressures up to 500 bar for smaller sizes and up to 140 bar for larger dimensions.

Triple-Lok®



The Parker Service Master Connect. Portable multi-function handheld measuring instrument.

Measures, stores, monitors and analyses pressure, temperature, flow and rotational speeds. Multiple measurement and triggering methods. Measurement and display of more than 100 channels.



...of excellent quality

The manufacture of quality high-performance fitting components starts already at the ordering stage for the crack-tested primary material, which must be in accordance with Parker material specifications specially determined for product manufacture. Through the processing stages required both before and after production, those properties which will fulfil constantly increasing material requirements are guaranteed.

To ensure that the high quality of the materials used and the tube fittings made from them are guaranteed, continuous tests e.g. spectral analysis and dye penetration tests, are carried out in our own laboratories and testing facilities. The fittings systems' resistance to corrosion and static and dynamic loads are put through their paces on in-house test stands.



Top-class products result from selected materials and the most up-to-date manufacturing methods. Functionally reliable and durable. Quality pays off.

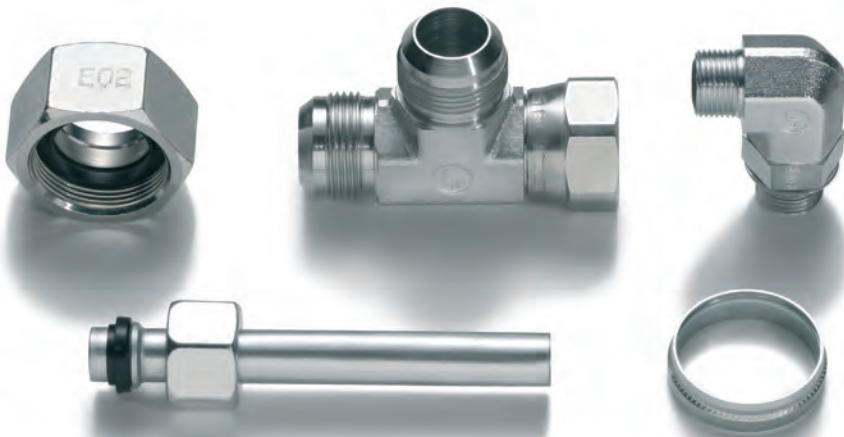

Thermal Management



The requirements for quick connect couplings for tempering and thermal management are extremely high.

Whether for applications in the area of renewable energies, for computer cooling, in transport or for industrial applications the coupling systems from Parker offer optimally tailored solutions.

Our systems stand out for their high level of compatibility with the broadest range of liquids (for example water or heat exchange oils) and the application environment.

Likewise, their resistance to mechanical stresses are vital. One of the most important requirements in the cooling of electronic systems

is the avoidance of any fluid loss, as this is the only way to guarantee faultfree function of the installation.

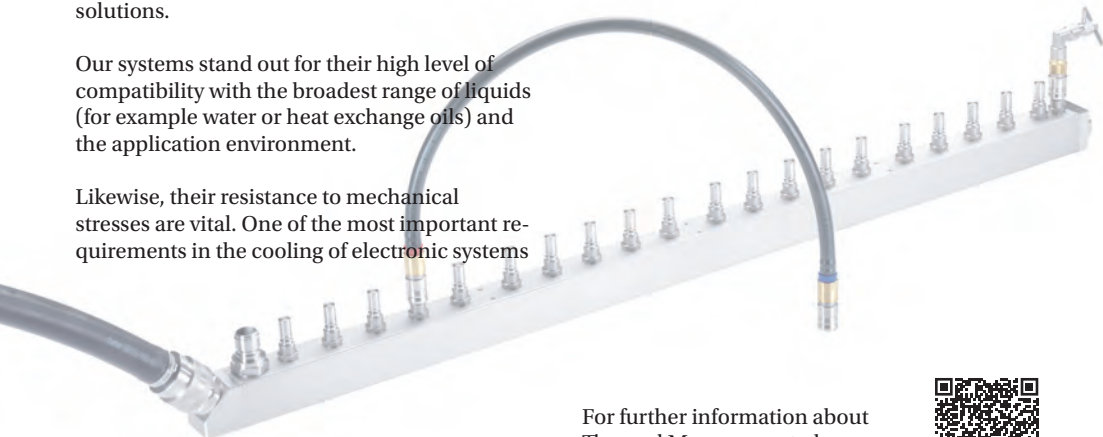

For further information about Thermal Management please see the PDF file:



Service before and after sales

To support its products, Parker offers its customers a comprehensive selection of services, i.e.

The Parker Store

Providing outstanding expert consultation, it was one of the first self-service shops for hydraulic and pneumatic fittings - and much more besides. It offers immediate manufacture of hose assemblies. Up to 3,000 items from stock.

Parker Hose Doctor

This emergency service can be reached via a toll-free hotline 24 hours a day, 7 days a week. Hose Doctor vans have fully-equipped workshops, spare parts and hydraulic oils on board. This enables the technician to rapidly replace faulty assemblies on site.

Tech Services

Together with the customer, Parker engineers assess on site the optimal operation of the equipment in question. They are present from the design stage through to installation and carry out training for operatives.

Kitting Services

Should the customer require a particular set of fittings and related items, Parker can supply these items under a single reference number as a totally complete assembly set.

Parker Logistic Services

Parker products can be supplied either directly from Parker or through a certified distributor on a just-in-time basis straight to the assembly point.

www.parkerstore.com



More than a product:

Parker offers an elaborated service to the customers.



Online: High Pressure Connectors Europe

Whether it be product information, catalogues, brochures or approvals, all the information you may require can quickly be found on, and downloaded from, our website

www.parker.com/hpce

Or if in your design activities you need CAD data for any product, simply visit our website

<http://parker.partcommunity.com/portal/portal/parker>

and you can then download the relevant data after prior registration.



Detailed Table of Contents

Function of fittings	Section A	Performance data	Section C
Tube Connection Systems DIN	3	Pressure rating	2
EO-PSR: Progressive Stop Ring for steel fittings.....	4	Pressure reductions and temperatures	2
EO progressive ring DPR for stainless steel fittings....	6	Materials.....	3
EO-2	9	Surface treatment.....	4
EO2-FORM.....	13	Fluid compatibility	5
EO-Weld nipple	16	Biodegradable oils.....	8
O-Lok®	17	Flow characteristics	9
Parflange® orbital flaring process	20	Flow diameter and wall thickness	13
Triple-Lok®	23		
Adapters	27	Dimensioning	Section D
Thread configurations	31	Overview EO 24° cone connections.....	3
		Not recommended	4
Systematic fitting selection	Section B	EO 24° cone end (DIN 3865/ISO 8434-1)/dimension	4
Introduction	2	EO 24°-DKO swivel connector (DIN 3861/DIN EN ISO 8434-4)/dimensions.....	5
Design criteria for fitting selection.....	2	Overview O-Lok® connections	6–7
Best solution.....	2	O-Lok® end (ISO 8434-3/SAE J1453)/dimensions.....	8
Material selection: Fitting material.....	3	O-Lok® swivel connector (ISO 8434-3/SAE J1453)/dimensions.....	9
Material selection: Sealing material.....	4	Overview Triple-Lok® connections	10–11
LL/L/S Series selection for EO fittings	5	Triple-Lok® end (ISO 8434-2/SAE J514)/dimensions.....	12
Tube end selection	6–7	Triple-Lok® swivel connector (ISO 8434-3/SAE J514)/dimensions.....	13
Flange type selection	8	DIN 60° cone end (DIN 7631)/dimensions	14
Port/Stud selection.....	9–11	Adapter 60° cone end (ISO/DIS 8434-6)/dimensions.....	15
Orientable fitting selection.....	12–13	NPSM Swivel adapters (SAE J516)/dimensions	16
Standardization	14	Male stud ends/ Port end dimensions for tube fittings	17–19
Approvals	14		
Tube Specifications	15–16		
Fitting selection summary	17		
Dry technology versus traditional technology	17–20		

Contents

Detailed Table of Contents

Tube assembly	Section E	EO-KARRYFORM	25
Fitting assembly	Section F	WorkCenter for EO2-FORM high pressure tube connections	28–30
Trouble shooting guide	Section G	Flaring tools for Triple-Lok® tubes	31
Tooling	Section H	Flaring tool selection guide	31
Parker tube fabricating equipment	4	Manual flaring tools for Triple-Lok® tubes	32
Manual assembly tools for EO/EO-2	5	Combination impact flarer 1004 for small dimension metric tube	32
VOMO – Pre-assembly tools for EO/EO-2 tube connections	5	Impact flaring tools for metric and inch tube	33
KONU – Cone-template for tools VOMO/MOK/MOSI	6	KARRYFLARE Portable flaring device for Triple-Lok®	34
Selection guide: Checking equipment for EO assembly	6	Parflare ECO mobile flaring machine for Triple-Lok® hydraulic fittings	35–36
Distance Gauge for Assembly AKL	7	37° flaring tools for KARRYFLARE device and Parflare ECO, EOMAT UNI, II and III	37
Manual assembly devices for EO/EO-2 tube connections	8	Assembly machines for O-Lok® and Triple-Lok®	38
Machine selection guide	8	Parflange® machine selection guide	38
HVM-B Pre-assembly tool	9–10	Parflange® 1025 workshop machine for O-Lok® and Triple-Lok®	39–40
EO-KARRYMAT portable pre-assembly device for EO tube connections	11	Parflange® 50 WorkCenter	41
Assembly machines for EO/EO-2 and Triple-Lok®	12	Parflange® 50 Basic WorkCenter	42
Machine selection guide	12	Parflange® 50 Pro WorkCenter	43
EOMAT ECO Mobile assembly machine for EO-2 and PSR hydraulic fittings	13–14	Parflange® 50 Ordering	44
EOMAT UNI Assembly and flaring machine	15–18	Tooling for Parflange® machines	45
EO PSR/DPR and EO-2 assembly tools for EOMAT/EO-KARRYMAT	19	Parflange® tool identification	46
Ferulok assembly tools for EOMAT/EO-KARRYMAT	20	Parflange® tools for O-Lok®	47
EOMAT PRO – Economic assembly machine for EO-2 and progressive ring fittings	21–22	Parflange® tools for Triple-Lok®	48
Assembly tools for EO fittings	23	Lubricants	49
The WorkCenter F3	24	EO-NIROMONT lubricant for fitting assembly	49
The WorkCenter PRO22	24	Cutting and bending tools	50
		AV 6/42 – Tube saw square	50
		BAV 6/12 – Combined tube bending and cutting tool	51
		In-Ex tube deburring tool	51
		BV 6/18 – Tube bending tool	52

Detailed Table of Contents

BV 20/25 – Tube bending tool.....	53	Weld fittings	Section M
Par-Lok wrench	54	Contents.....	2
WZK – Tool boxes	55	High Pressure Hydraulic Flanges	Section N
O-ring assembly tools	56	Introduction	4
Corg O-ring installation tool for O-Lok®	56	Design and construction	4
O-ring pick for O-Lok®	56	Methods of connection	5
Port cutting tools.....	57	How flange connections work.....	6
Counterbore tools and thread taps for metric ports.....	57	Assembly of flanges	7
Counterbore tools and thread taps for straight SAE thread ports.....	57	Bolt torques for SAE flanges	8
Operation of port cutting tools	58	Technical data	9
Thread identification.....	59	Order codes bolts and O-rings.....	10
Thread identification kit.....	59	Features, advantages and benefits	11
Portboard	59	How to order	12
HPCE sample case.....	60	Visual index	13
DIN fittings	Section I	SAE Flange clamps	16
Contents.....	2–5	SAE Flange adapters	
How to order	6	EO 24° cone end	21
How to order EO fittings	7	BSPP 60° cone end.....	25
Codes for fittings/styles shapes	8–9	Male NPT thread	27
O-Lok®	Section J	O-Lok® ORFS end.....	28
Contents.....	2–3	Triple-Lok® 37° flare end	31
How to order O-Lok® fittings	4	Butt weld end	34
Triple-Lok®	Section K	Socket weld end.....	39
Contents.....	2–3	SAE Full flanges	
How to order Triple-Lok® fittings	4	Female BSPP thread	42
Ferulok®	Section L	Female NPT thread.....	46
Contents.....	2–3	EO 24° cone end	49
How to order Ferulok® fittings	4	BSPP 60° cone end.....	51
		Triple-Lok® 37° flare end	53
		O-Lok® ORFS end.....	55
		Butt weld end	57
		Socket weld end.....	60
		Complete flange connections	64

Contents

Detailed Table of Contents

SAE Flange accessories	67	Acc. to DIN EN 10216-5, DIN 10305-1	13
Gear pump flanges		Seamless EO tube bends 90°	
EO 24° cone end	75	Material E235N (St. 37.4) and 1.4571	14
O-Lok® ORFS end	78		
Male/Female BSPP thread	80	Tube clamps	Section T
Socket weld end	82	Contents	2
Special pump size flanges	83	Technical data	3
Aluminium flanges	86	Material properties	4
ISO 6164 Square flanges	88	Special materials	5
		Assembly instruction	6
Adapters	Section O	Series A Light series (DIN 3015-1)	8
Contents	2-3	Series B Double series (DIN 3015-3)	24
		Series C Heavy series (DIN 3015-2)	29
Valves	Section P	Multiclamps	38
Contents	2-7	Hydraulic steel clamps	46
		Tube clamps with Elastomer inlay	48
Rotary fittings	Section Q	Fixed adaptor	51
Contents	2		
Parker SensoControl®	Section R	Custom Products	Section U
Contents	2		
Tubes	Section S	Alphanumerical index	Section V
General recommendations for tubes	3		
Seamless EO steel tubes			
Material E235+N / St. 37.4 (1.0308)			
Acc. to DIN EN 10305-4	8-9		
Seamless EO steel tubes			
Material E355+N / St.52.4 (1.0580)			
Acc. to DIN EN 10305-4	10		
Seamless EO stainless steel tubes			
Material 316Ti (1.4571)			
Acc. to DIN EN 10216/5, DIN EN 10305-1	11		
Seamless EO stainless steel tubes			
Material 316L (1.4404)			
Acc. to ASTM A269/A213, DIN EN 10305-4	12		
Seamless EO stainless steel tubes			
Material 316L (1.4404)			



Function of fittings





Index

Tube Connection Systems DIN A3

EO-PSR: Progressive Stop Ring for steel fittings A4

EO progressive ring DPR for stainless steel fittings..... A6

EO-2 A9

EO2-FORM..... A13

EO-Weld nipple A16

O-Lok® A17

Parflange® orbital flaring process A20

Triple-Lok® A23

Adapters..... A27

Thread configurations A31

Function of fittings

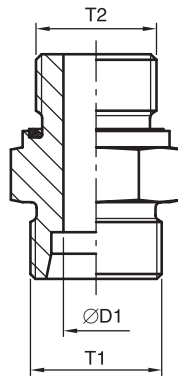

1) Weld nipple for steel and stainless steel EO-DUR fittings, series L + S

- Excellent leakage free performance due to elastomeric sealing element
- Low requirements on tube quality

2) E02-FORM Soft sealed tube forming system for steel and stainless steel EO-DUR fittings, series L + S

- Based on EO-2: Optimal leak free performance due to replaceable elastomeric sealing element
- Cutting ring free – best possible alternative to welding for applications, where form closing connections are required
- Assembly-proof – reduction of error sources due to machined pre-assembly/tube forming

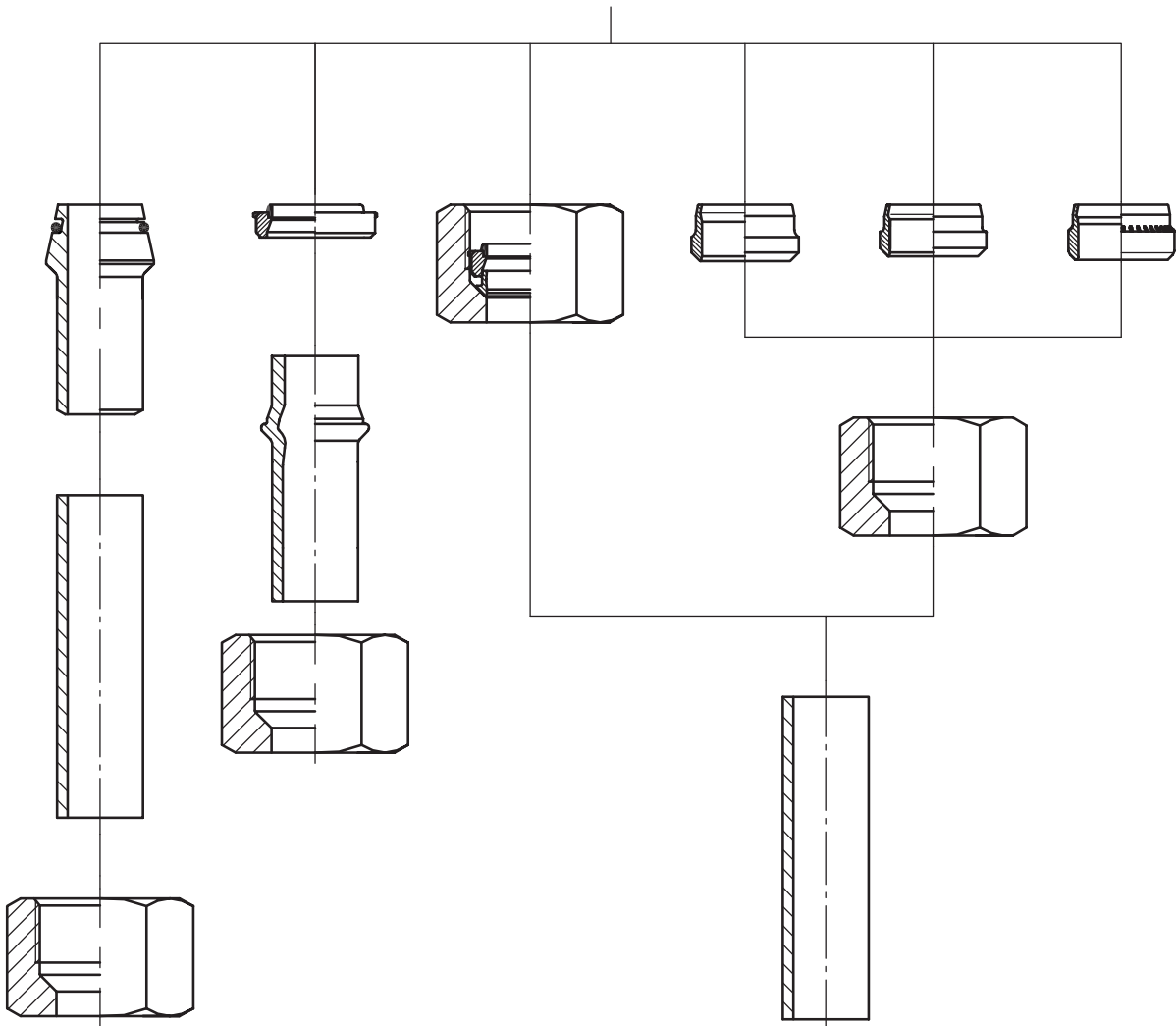

3) EO-2 Soft sealed bite-type system for steel and stainless steel EO-DUR fittings, series L + S

- Optimal leak free performance due to elastomeric sealing element
- Easy assembly "on block" – also directly in fitting body
- Safety due to clear assembly check
- Replaceable sealing element

4) Cutting ring for steel and stainless steel EO-DUR fittings, series LL, as well as brass fittings, series L + S

- For decades approved cutting ring
- Tube clamping to transfer vibration and to protect the tube within the cutting area
- Spring effect – no settlement of the nut

5) DPR EO-progressive ring for stainless steel EO-DUR fittings, series L + S

- Especially adjusted to the requirements of stainless steel
- Optional in "SPH" finish – thereby despite of hardening no loss of corrosion resistance

6) EO-PSR Progressive Stop Ring for steel fittings, series L + S

- 2 cutting edges for optimal holding function and tear-off protection
- Over-assembly protection due to clear noticeable increase in force and stop shape
- Tube clamping to transfer vibration and to protect the tube within the cutting area

EO-PSR: Progressive Stop Ring for steel fittings

Introduction

The worldwide well-established high-pressure-fitting system is characterized by the highest pressure, Cr(VI)-free surface treatment with significantly higher corrosion resistance, and considerably reduced tightening torques.

The ingenious invention of the cutting ring system was made by the founder of Parker Ermeto in the late nineteen twenties. In 1934, this idea was patented and today it is just as useful as it was on the very first day. Considering the range of applications, quality, reliability and functional safety, the principle of the Parker's cutting ring fitting has been a leading system up to today.

Of course, this has only been possible by continuously adapting the original invention from 1934 to the practical requirements of state of the art technology. Thus, the first Parker Ermeto cutting ring has little left in common with the latest multifunctional EO-PSR cutting ring, the heart of EO-PSR.

The EO-PSR fitting meets the requirements of modern hydraulic systems. This is especially true for applications where the systems are exposed to extremely high loads.

EO-PSR is designed for metric tube and based on German Standards DIN 3861 and DIN 2353, which today are represented by the international standard ISO 8434-1. EO-PSR is available in "L"- and "S"-Series.

The EO-PSR (Progressive Stop Ring) is available for the steel fitting range. For stainless steel applications, the Progressive ring DPR 71 is used and the Cutting ring for brass fittings and series LL.

EO-PSR fitting features

The EO-PSR fitting produces high pressure, leak free connection of tubes and components in hydraulic systems. The basic function of EO-PSR is the controlled progressive bite of the EO-PSR into the tube due to a unique internal geometry.

The front cutting edge (A) has already started cutting into the tube before the second cutting edge (B) begins. As soon as both cutting edges have cut into the tube to the designed depth further advance is limited by the stop shape (C) and the new overtightening protection (D). Additionally, the special form of the EO-PSR with its dimples at the front shoulder section gives an assembly state control.

Owing to the design of both cutting edges and stop shape all forces arising are equally distributed. This distribution along with the specially designed interior collar (E) of the ring guarantees increased safety, particularly with regard to vibration and flexure stresses. Service vibration loading is not present in the areas of the tubing where the bite is made.

The stop shape as well as the overtightening protection cause a clear sharp increase in tightening forces. After assembly, a visible collar (F) of cut tube material must completely fill the space in front of the first cutting edge. A slight bowing up of the ring (G) is desirable. This spring effect provides permanent compensation for flexural vibration and settling effects in the thread of the fitting nuts.

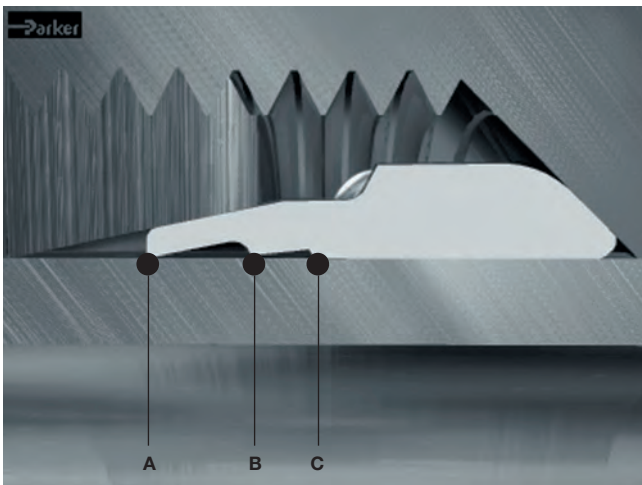

Before tightening the nut

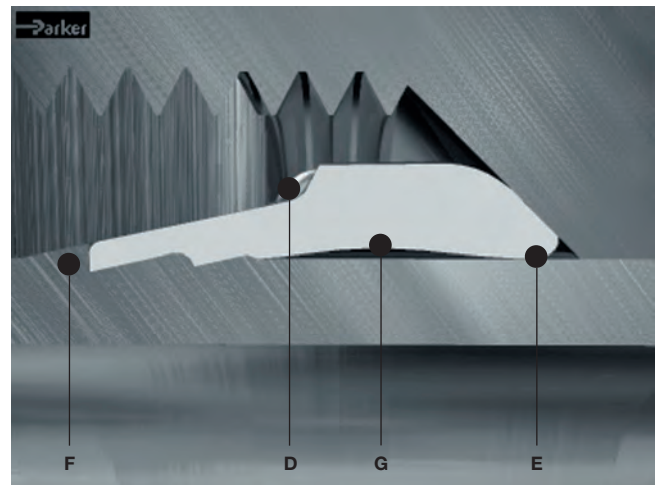

After tightening the nut

Assembly

Assembly process is according to the EO-Progressive ring instruction. The design allows a 100%-pre-assembly for an easier final assembly.

Features, advantages and benefits of EO-PSR fittings

- **High corrosion resistance** – The Cr(VI)-free surface treatment causes an average corrosion resistance of more than 500 hours to white rust.
- **High pressure** – Due to the application of even better materials combined with the special processing of individual components, EO-PSR can be used in applications of up to 800 bar (S series) and 500 bar (L series). EO-PSR considerably exceeds the DIN/ISO requirements and guarantees a 4-fold design factor. Thanks to the higher pressure levels, less expensive “L” series fittings can now be used instead of the heavier “S” series, which also is of benefit in limited or tight space applications.
- **EO-LUB** – Due to the special treatment of the larger sized nuts by the EO-LUB procedure (25S/28L and larger), the tightening torques of EO-PSR fittings have been reduced by 25%. This makes assembly easier and prevents underassembly, the most common reason for tube fitting failure.
- **Safe assembly** – Two distinctive cutting edges provide a progressive increase of the tightening torque of the EO-PSR. The noticeable end point of assembly contributes to maximum safety of assembly, and the multifunctional ring geometry prevents over-tightening.
- **Overtightening protection** – The special geometry of the EO-PSR prevents the overassembly of EO-PSR fittings.
- **Spring effect** – Thanks to the spring effect, re-tightening of the fitting is not necessary. Upon the completion of the assembly (due to the geometry, material and heat treatment) an elastic initial tension is achieved which compensates displacement effects in the thread and at the bite point of the tube.
- **Cr(VI)-free** – Due to its Cr(VI)-free treated surface, Parker Ermeto meets the requirements of the automotive industry which prohibits the use of Cr(VI) since 2007. The removal of Cr(VI) reflects Parker's ongoing commitment to an environmentally clean and safe production process.
- **Worldwide availability** – EO-PSR is available worldwide and meets the requirements of the applicable standards for 24° cutting ring fittings. The multifunctional EO-PSR can be used with all types, series and dimensions of the wide range of EO-PSR fittings.



The multifunctional EO-PSR



Classical application of the EO-PSR: Cranes

EO-DUR Progressive Ring DPR for stainless steel fittings

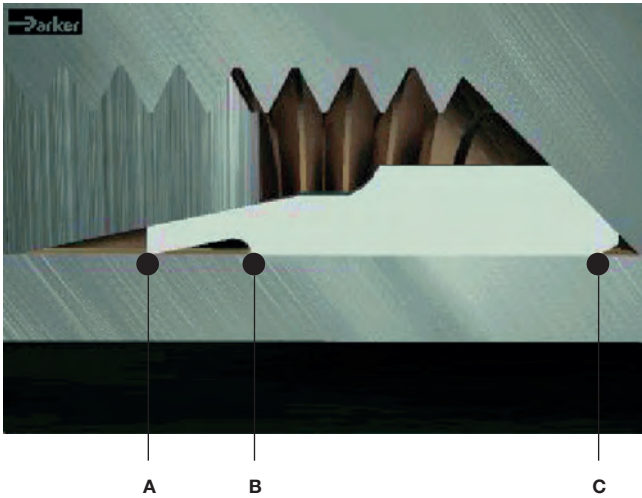

Before tightening the nut

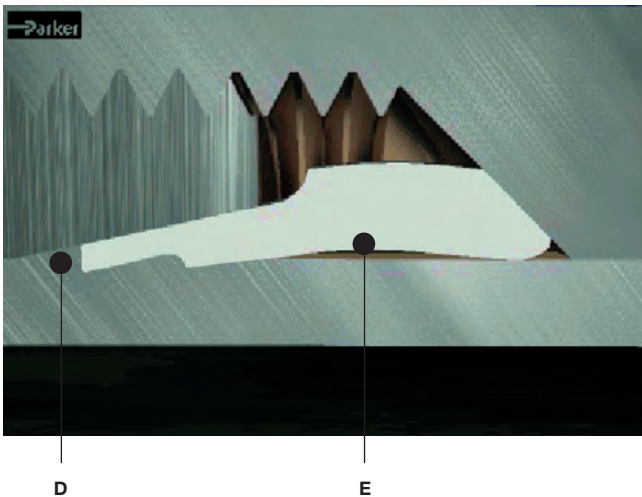

After tightening the nut

The proper assembly result is achieved by 1½ turns of the nut.

The function of the EO stainless steel progressive ring fitting

The EO progressive ring fitting produces a low to high pressure, leak free connection of tubes and components in hydraulic systems. The basic function of the EO progressive ring is the controlled progressive bite of the ring into the tube due to its unique internal geometry. The design of the EO-DUR stainless steel progressive ring is based on three essential functions.

The front cutting edge (A) has already started cutting into the tube before the second cutting edge (B) starts. As soon as both cutting edges have cut into the tube to the designed depth further advance is limited.

Owing to the design of both cutting edges all forces arising are equally distributed. This distribution along with the specially designed interior collar (C) of the ring

guarantees increased safety, particularly with regard to vibration and flexure stresses. The design and function of the cutting ring ensure that service vibration loading is not present in the areas of the tubing where the bite is made.

After assembly, a visible collar (D) of cut tube material must completely fill the space in front of the first cutting edge. With stainless steel tube and standpipe hose connections, the collar is smaller due to the harder material.

A slight bowing up of the ring (E) is desirable while this happens. This spring effect provides permanent compensation for flexural vibration and setting effects in the thread of the fitting nuts.

All EO-DUR stainless steel fittings show a special progressive ring design for best performance with stainless steel tubes. LL – series fittings and all brass fittings are equipped with a single bite “D”-ring.

The spring effect

$$\textcircled{1} + \textcircled{2} + \textcircled{3} = 1\frac{1}{2} \textcircled{R}$$

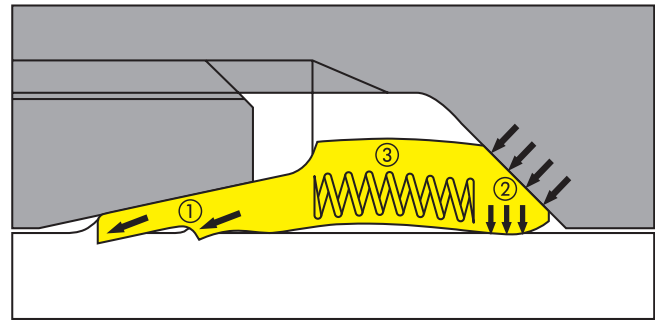

The 3 vital effects of Progressive-Ring assembly: sealing (1), tube clamping (2), spring effect (3).

During assembly of the EO progressive ring fitting, three essential functions are achieved:

① Tube bite

The tube bite guarantees the leak free sealing and ensures the necessary holding power for high operating pressures. After assembly, a collar of cut tube material in front of the cutting edge is the visible control for the proper function of the connection.

② Tube clamping

The rear section of the progressive ring is designed for clamping the tube firmly. This ensures that service vibration loading is not present in the tube bite area.

③ Spring effect

Towards the end of assembly, the special EO progres-

sive ring design, material and heat treatment allow a defined elastic deformation of the ring. This spring effect compensates subsidences of tube bite and threads, thus ensuring long term leakfree performance without retightening.

EO-DUR stainless steel products with silver plated threads

All threads of the EO-DUR stainless steel nuts are surface treated to reduce the tightening-torques by 40 % compared to non treated products. The treatment also avoids galling of the threads. Nuts larger than size 12S/15L are delivered with silver plated threads, all smaller sizes are treated with a special wax.

The EO-DUR Suparcased SPH cutting ring

On the basis of the proven progressive ring design, the suparcased stainless steel bite-type ring has been developed especially for aggressive internal and external media. The special geometry and thermochemical hardening process guarantee a permanently leak-proof and corrosion-resistant connection under extreme conditions. Typical applications are in the food, chemical and medical industries as well as in process engineering.

Common features, advantages and benefits of the EO Bite type system

- **Field assembly** – EO progressive ring fittings can be assembled anywhere with just a couple of wrenches. For stainless steel tube simple presetting tools are available. No additional equipment or machine is required.
- **Low cost assembly** – Using an EOMAT machine is the most economic method to preassemble EO rings onto tube ends. Whereas the actual preassembly process only takes some 1.4 seconds on the EOMAT, the total “floor-to-floor” time averages around 15 seconds.
- **3 series** – Very Light (LL), Light (L) and Heavy (S) series can be individually selected. For each application there is a solution for best flow rate, sufficient pressure resistance, smallest envelope size, low assembly force and minimum fitting cost.
- **Available sizes** – Most EO fittings are available in 25 sizes from 4 to 42 mm tube OD. Additional reducers allow optimum dimensioning of each individual fluid line. This saves space and material costs.
- **Tube wall** – EO fittings are suitable for use with light wall, medium wall, heavy wall, and extra heavy wall tubing. Light wall tube may require support sleeve (VH). Usage of VH, see chapter E.

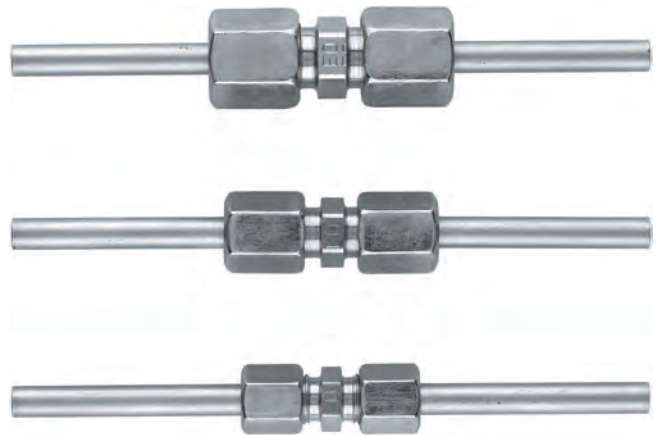

Top to bottom: EO Heavy (S), Light (L) and Very Light (LL) series: Best choice for each individual application (Illustration: Straight union 6 mm tube OD)

- **Tube material** – Even plastic tubes such as nylon, polyurethane, chlorinated polyvinyl chloride (PVC) or Polytetrafluoroethylene (PTFE) can be easily connected by using additional support sleeves E.
- **Visible bite** – The critical ring to tube front bite is clearly visible to tube fitters & inspectors. The presence of the recommended bite virtually eliminates any risk of catastrophic blow-off. This is a very important safety feature.
- **Reduced torque** – All nuts of EO-fittings are coated with a highly effective lubricant. Reduced assembly effort helps to prevent underassembly which is the most common reason for bite type fitting failure.
- **Sealing capability** – EO fittings have demonstrated a remarkable ability to remain leak free under various service conditions ranging from sealing high vacuum and small molecule gases to high pressure hydraulic fluids.
- **Distributed stresses** – Stresses due to flexural loading in service are distributed at several points in the joint, thus stress concentration in the bite is minimised.
- **Vibration control** – The rear bevel of the ring firmly grips tubing, thus dampening the effects of system vibration in the joint.
- **Envelope size** – EO fittings are comparatively small and compact, making them a suitable selection for tube connections in limited or tight spaces.
- **Temperature rating** – EO fittings are suitable for sub zero through elevated temperature applications. Service temperature rating is limited by the material chosen.

Function of fittings

- **Compatibility** – Since EO fittings can be manufactured from a wide range of metals, compatibility factor with various fluids and atmospheric conditions is extensive.
- **Manufacture** – EO fittings are manufactured under tight quality controls which ensures that the product routinely satisfies or surpasses the requirements of the pertinent military and industrial standards. All manufacturing locations are ISO 9001 certified.
- **Silver plated nuts** – Stainless steel tube nuts are pre-lubricated with silver plated threads (size 15L – 42L, 12S – 38S). The threads of smaller sized stainless steel nuts are waxed. Thread galling is eliminated and assembly torque is reduced by as much as 40 percent. The EO-DUR treatment increases the speed and efficiency of stainless steel fitting assembly.
- **Tube length determination** – Exact tube length and bending can easily be checked by just trying out before assembly. This makes on-site piping very efficient.
- **Broad range of configurations** – EO fittings are available in more than 50 configurations. Especially for orientable fittings there is a wide variety of banjos, adjustable elbows or swivel combinations that allow an optimum solution for each application.
- **Functional fittings** – A variety of rotary fittings, non-return valves, Shut-off valves and test point connectors are available with the original EO-joint. This greatly reduces assembly time and cost of additional fittings and also eliminates possible leak paths.
- **True metric design** – EO fittings are designed to metric standards. All threads, hexagons, bores and other dimensions are purely metric.
- **No restrictions** – All bores of each fitting fit the inner diameter of the matching tube. LL, L and S-Series fittings are designed for best flow rate with thin, medium and heavy wall tube. Therefore, best performance without excessive noise or heat generation is always guaranteed.
- **World wide popularity** – The bite type fitting has worldwide acceptance. Most European, Asian, African and South American industry standards are purely metric. But also in Australia and Northern America DIN bite type fittings are gaining acceptance due to the metrification and end user specifications. Many machine operators prefer fittings that can be assembled without any additional equipment.

EO-2

Introduction

The common feature of all EO-2 fittings is elastomeric seals on all joints. These are also now available in FKM for applications with higher temperatures or aggressive media. This assures leak free operation without retightening – even under extreme working conditions. The easy handling, time and cost saving features, and many assembly advantages of the unique EO-2 functional nuts have made EO-2 fittings increasingly popular.

EO-2 is designed for metric tube and based on German Standards DIN 3861 and DIN 2353, which today are represented by the international standard ISO 8434-1. EO-2 is available in “LL”, “L”- and “S”-Series.



The Cr(VI) free EO-2 functional nut also with FKM sealing ring. Easy to handle and fast to assemble.

Function of the EO-2 fitting system

Elastomeric sealing

The elastomeric seal assures a hermetically sealed tube joint. It is located between the inner cone of the fitting body and the tube surface, thus blocking the only possible leak path. Due to its large cross-section, the seal effectively compensates for all manufacturing tolerances on tube and fitting cone.

The sealing effect is pressure supported which makes the EO-2 fitting suitable for high pressure applications. The static compression also eliminates air-ingress into the fluid system at vacuum conditions.

Elastomerically sealed EO-2 fittings do not require any retightening even in heavy duty applications. Seal extrusion is prevented by proper housing without gaps or dead volume. The sealing lip is bonded to a metallic support ring.



EO-2: Safe dry – clean – leakfree

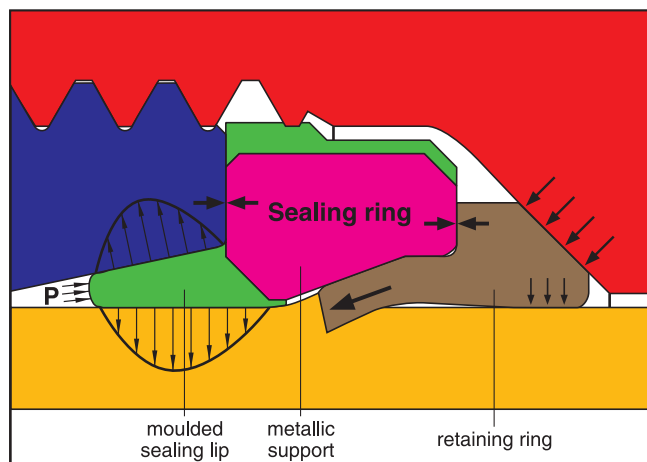

The metallic support of the sealing ring acts just like an integrated pre-assembly tool.

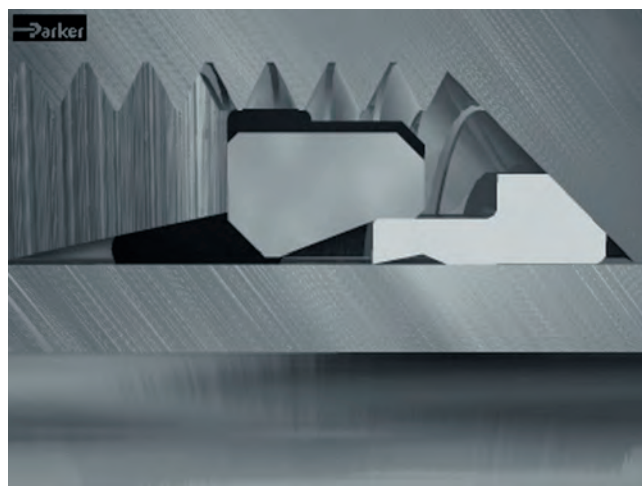

Before tightening the nut

Function of fittings

Assembly “to block”

The retaining ring bites into the tube in accordance to the proven bite ring principle. The support ring reduces the danger of over- or underassembly by a special EO-2 design feature: Before assembly there is a gap in between the flat surfaces of the retaining ring and the metallic support ring of the seal. As soon as the retaining ring has reached the proper bite depth, the gap closes, resulting in a sharp increase of assembly torque. This results in uniform and reliable fitting assemblies. The assembly result can easily be inspected by just checking if the gap is closed.

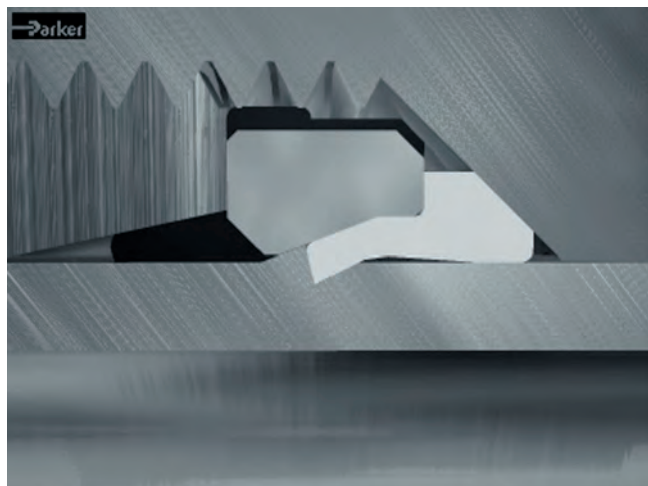

After tightening the nut

Closing the gap at the end of assembly provides a clear “Hit-Home-Feel”.

The separation of sealing and fixing function to two separate elements finally allows a more effective solution of the over- and undertightening problems of bite type fittings than increasing the number of cutting edges.

Integrated assembly tool

The metallic support ring of the seal is made of a special design, material and heat-treatment to act as a assembly tool. This makes sure that the retaining ring securely cuts into the tube surface without damaging the sensitive inner cone of the fitting body.

This unique feature of EO-2 fittings even allows direct assembly of stainless steel tube without any additional pre-assembly process. An EOMAT machine can be used to allow easy assembly of large dimension tube and drastically save total assembly time, effort and costs.

The integrated assembly tool of EO-2 fittings even helps to save further costs and trouble when using an EOMAT-type presetting machine:

As the presetting cone is only in contact with the elasto-

meric sealing lip, it cannot be worn out or damaged even after thousands of assemblies. This does not only save replacement costs but also avoids leakage problems caused by worn presetting tools.

The functional nut

The unique functional nut simplifies handling of fitting components and helps to minimise storage and procurement costs. The sealing and retaining rings are combined as a pair and are inserted into the internal thread of the nut in such a manner that they cannot fall out, so that these three parts form one functional element.

Individual components such as seals or retaining rings cannot be forgotten, confused or assembled in the wrong orientation. Time and cost is saved arranging the components to make up individual joints.

The functional nuts match all EO tube fitting joints. After assembly and disassembly, the sealing ring can be replaced individually without cutting off the tube end.

Common features, advantages and benefits of the EO-2 fitting system

- **High corrosion resistance** – The Cr(VI)-free surface treatment causes an average corrosion resistance of more than 500 hours to white rust.
- **Increased pressure** – Due to the application of even better materials combined with the special processing of individual components, EO-2 can be used in applications of up to 800 bar (S series) and 500 bar (L series). EO-2 considerably exceeds the DIN/ISO requirements and guarantees a 4-fold design factor. Thanks to the higher pressure levels, less expensive “L” series fittings can now be used instead of the heavier “S” series, which also is of benefit in limited or tight space applications.
- **EO-LUB** – Due to the special treatment of the larger sized nuts by the EO-LUB procedure (25S/28L and larger), the tightening torques of EO-2 fittings have been reduced by 25%. This makes assembly easier and prevents underassembly, the most common reason for tube fitting failure.
- **Cr(VI)-free** – Due to its Cr(VI)-free treated surface, Parker Ermeto now meets the requirements to be expected in the automotive industry and the expected requirements issued by the European Parliament to eliminate the use of materials and surfaces containing Cr(VI). The removal of Cr(VI) reflects Parker’s ongoing commitment to an environmentally clean and safe production process.

- **Worldwide availability** – EO-2 is available worldwide and meets the requirements of the applicable standards for 24° cutting ring fittings.
- **Sealing capability** – An elastomeric seal forms the primary sealing element, thus assuring leakfree sealing. Even low-viscosity media such as water or gas are hermetically sealed. Hydraulic systems therefore do not “sweat” at fittings.
- **Durability** – The elastomeric seal does not require any retightening even after years of operation under extreme working conditions.

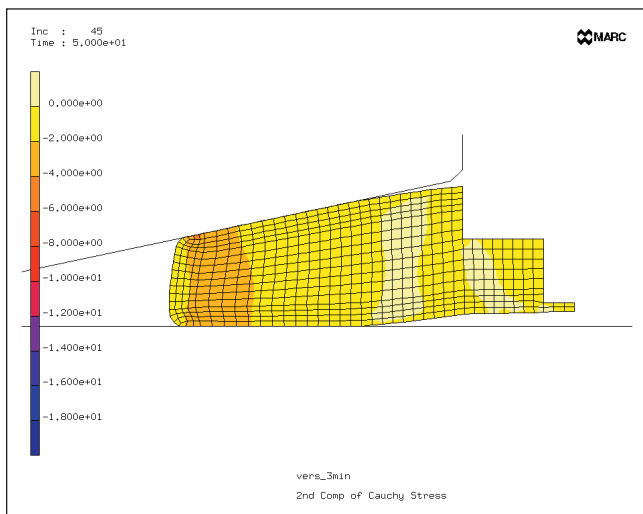

FEM (Finite Element Method) has been used to optimize the seal design (Picture: FES, Raiffeisenstr. 10a, D-74343 Sachsenheim).

- **Bite control** – The ideal bite depth is controlled by the fitting design rather than by the fitters force. Closing the gap at the end of manual assembly, the fits gets a clear signal that setting is completed and the joint is ready for inspection.
- **Functional nut** – Individual components such as the retaining ring or seal cannot be lost, forgotten, confused or assembled in the wrong orientation. This dramatically saves assembly cost and helps to avoid dangerous assembly errors.
- **Assembly cost** – With less than 10 seconds cycle time on the EOMAT (actual presetting process: 1.4 seconds) the cost of presetting EO-2 is extremely low.
- **Integrated preassembly tool** – Each EO-2 functional nut comes assembled with an integrated assembly tool that makes sure that the retaining ring securely cuts into the tube surface without damaging the sensitive inner cone of the fitting body. This greatly reduces the danger of tube blow-off, even when using stainless steel tube.
- **Reliable repeatability** – When EOMAT machines are used for cost-efficient presetting, the preassembly tools do not wear out as they are only in contact with the rubber seal. This avoids leaks and dangerous blow-off which can result when traditional bite-type fittings are assembled using worn presetting tools.
- **Final assembly** – From the wrench-tight position of the preset EO-2 joint, one short pull on the wrench (approx. 1/6 to 1/4 turn) gives the assembly a quick high rise to required torque. EO-2 fittings have a solid “Hit-home-feel” and excellent over-torque resistance.
- **Visible inspection** – There is no doubt if an EO-2 functional nut has been preset correctly or not. Inspection is as simple as checking if the gap between retaining ring and sealing ring is completely closed. The tube end does not have to be disassembled out of the fitting for bite inspection.
- **No phantom leaks** – Lubrication is not mandatory for the assembly of steel EO-2 fittings. The machine operator will not be irritated about lubricant coming out of the fittings once the hydraulic system gets hot.
- **Reusability/Remakeability** – EO-2 fittings can be disassembled and reassembled many times. There is no wear or widening of the vulnerable inner cone. Damaged seals can easily be replaced. All spare DOZ-seals are marked by size-code (e.g.: 12-L).
- **On-Site-Maintenance** – For the maintenance and replacement of EO-2 fittings a set of wrenches is sufficient. Additional in – line – components, such as test points (GMA), ball valves (KH) or Tee-fittings can be added to an existing assembly within minutes.
- **Interchangeability** – The EO-2 functional nut can be used for the whole variety of the broad range of more than 50 configurations in some 25 sizes of standard EO LL, L and S-series fittings. Changeover from progressive ring or weld nipple is easy by the simple use of EO-2 functional nuts.
- **Reliability** – Millions of EO-2 fittings are working trouble free in applications like: Mobile Construction equipment, stationary machine tools, hydraulic presses, plastic injection moulding machines, shipbuilding, offshore exploration, submarines, railway trains and military equipment. Leakage does not occur on EO-2 pipework.
- **Trouble-free** – Regular bite type fittings allow typical assembly-errors such as: confusion of bite type ring material and size. Also, the use of worn-out pre-assembly tool may result in fitting failure. The clever EO-2 design does not allow most of these mistakes without making the assembly process more complicated.

Function of fittings

- **Popularity** – EO-2 fittings are as easy to assemble as traditional bite type fittings, but they eliminate most of their typical assembly problems. EO-2 fittings are therefore appreciated by an increasing number of original

equipment manufactures. EO-2 also has become the fitting of choice of end-users that appreciate the leak-free performance, the easy maintenance and the global availability of the metric soft-seal bite type system.

Suitable FM-type

	Steel tube	Stainless tube	Plastic tube
Steel fittings body (EO-2)	FM...CF	FM...SSA	FM...CF
Stainless steel fitting body (EO-2)	—	FM...71	FM...71



EO-2 fittings are used for heavy-duty applications, such as construction equipment or plastic injection molding.

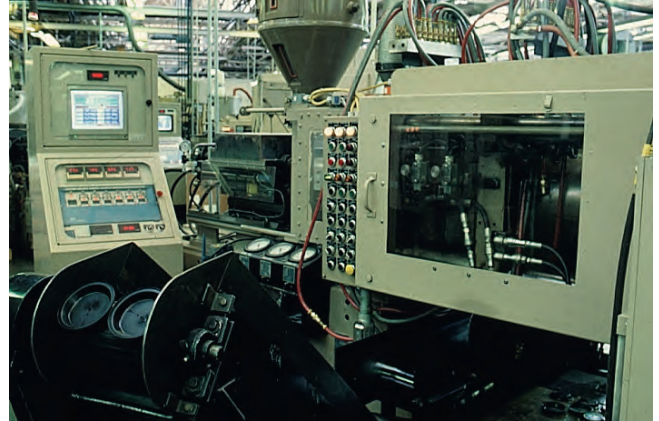

Every day millions of EO-2 fittings perform absolutely trouble-free.

EO2-FORM

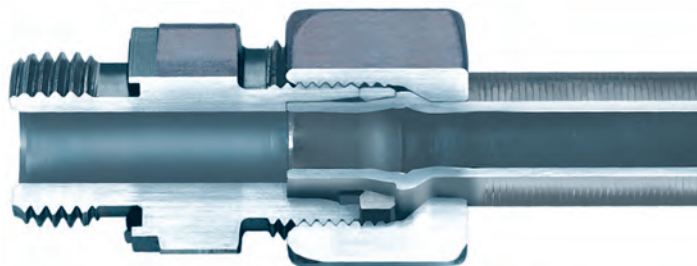

Introduction

EO2-FORM is the high pressure formed tube Generation of the High Pressure Connectors Europe division. As with EO-2, it is designed in to eliminate leakage in all fluid systems, by using elastomeric sealing systems.

The common feature of all EO2-FORM connections are the EO-2 seal elements as well as the new cold forming process, that gives extreme rigidity and low tightening torques. The seals are also available in FKM for applications with higher temperatures or aggressive media.

Through EO2-FORM, elastomeric sealing technology is made available even where bite-type connectors are not popular, like in hydraulic presses, cranes, lifts or ship canal locks. Compared to welding or brazing, the EO2-FORM process is faster and easier. It does not require special tube treatment, heating or chemicals.

EO2-FORM is designed for metric tube and fully interchangeable to the complete Ermeto Original product range according to ISO 8434-1/DIN 2353. EO2-FORM is available in "L"- and "S"-Series.

Function of EO2-FORM

EO-2/EO2-FORM system

EO2-FORM is not a stand-alone product. It has been developed as an extension of the proven EO-2 system product range. All EO2-FORM components like nuts, seals

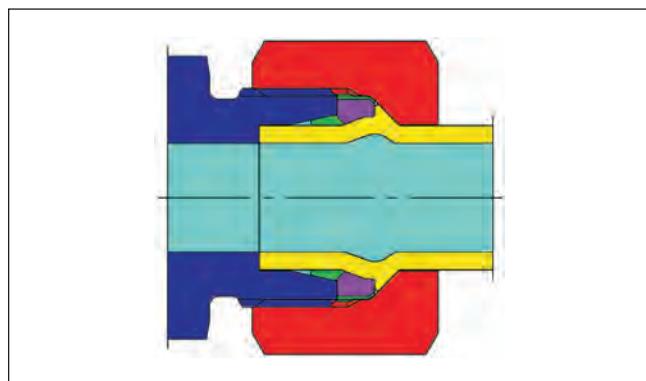

The EO2-FORM connection:
Extreme rigidity and low tightening torques



The EO2-FORM F3 machine

and fitting bodies come from the EO-2 program. The only investment needed is the forming machine, which pays off quickly as it reduces assembly time and effort. Assembly characteristics of EO2-FORM are similar to EO-2 too. This allows the customer to use both products for his hydraulic pipework without increasing stock or confusing workfloor engineers with new components.

Elastomeric sealing

For EO2-FORM, the same sealing ring "DOZ" is used as for EO-2. The high volume elastomeric seal assures a hermetically sealed tube joint. It is located between the inner cone of the fitting body and the tube surface, thus blocking the only possible leak path. Due to its large cross

The EO2-FORM process

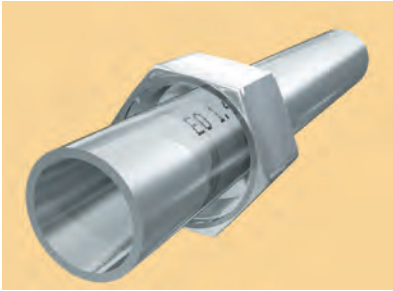

Tube end is prepared and equipped with EO nut

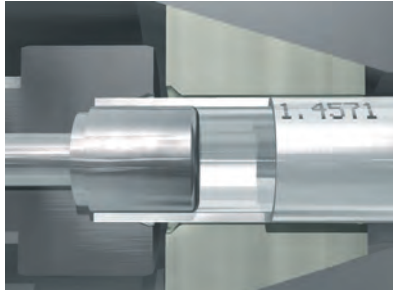

Tube is inserted into the tools until it firmly touches the stop at the end



After starting the process, the dies clamp the tube and the forming pin starts to move forward



While moving, the pin is continuously forming the tube wall and compressing the material



The tool shape defines the outer contour of the formed tube wall



The inner contour also gets slightly deformed but remains smooth and unrestricted for good flow characteristics

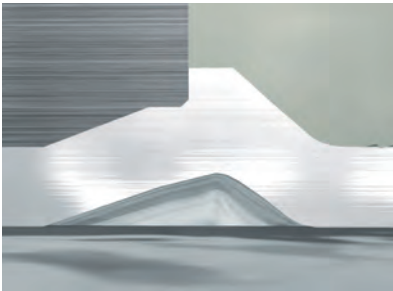

As soon as the moving pin touches the clamping jaws, the forming process is completed

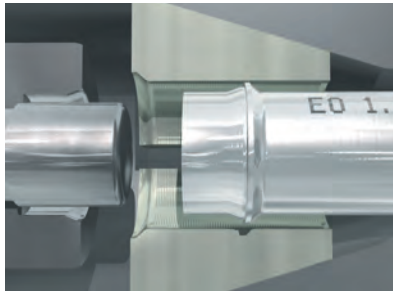

The tube end is released and ready for attaching the EO-2 seal



Installation is made in the fitting body

section, the seal effectively compensates for all manufacturing tolerances between the tube and fitting cone.

The sealing effect is pressure supported which makes the EO2-FORM fitting ideal for high pressure applications. The static compression also eliminates air-ingress into the fluid system in vacuum conditions. Elastomerically sealed EO2-FORM fittings do not require any retightening even in heavy-duty applications. Seal extrusion is prevented by proper housing without gaps or dead volume areas. The sealing lip is bonded to a metallic support ring.

Cold-formed tube

The cold-forming of the tube is carried out by the EO2-FORM machine. Machine operation and tool setup are optimised for short cycle times, which makes the process

easy and fast. The tube is connected when the sealing ring is fixed and the nut is tightened.

The working contact area of the EO2-FORM connection is the flat front surface of the metallic support ring which is made of heat-treated, high-strength steel. This provides superior mechanical strength without settling, loosening or need for re-tightening.

Features, advantages and benefits of the EO2-FORM fitting system

- **System solution** – No additional items need to be purchased or stocked on top of the existing EO-2 product range. Assembly characteristics of EO2-FORM are similar to EO-2.

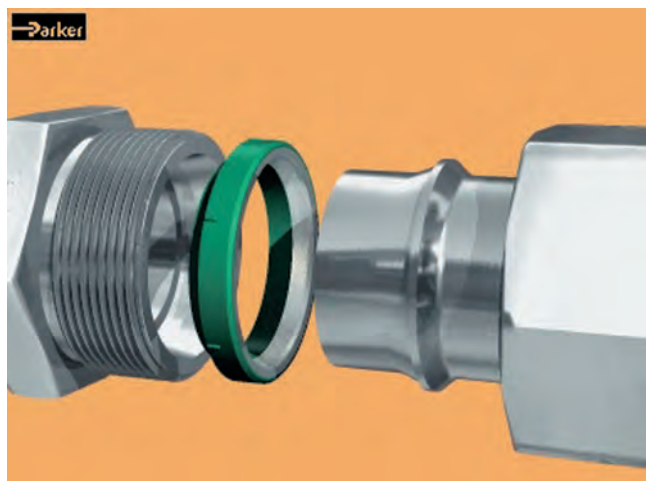

Before tightening the nut

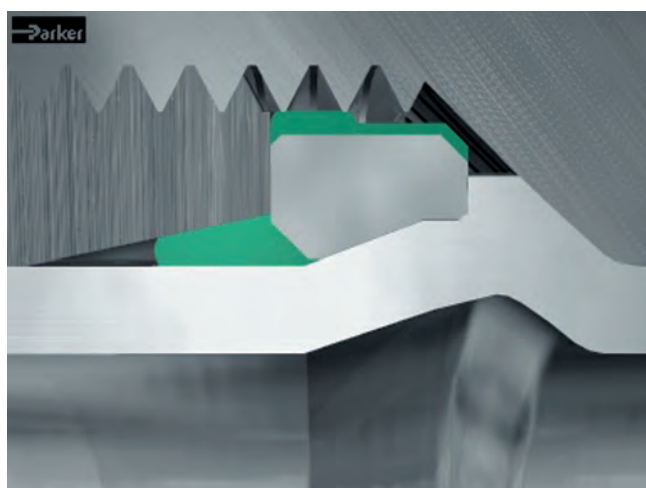

After tightening the nut

- Flexible concept** – The product family of EO-2 and EO2-FORM allows the application of the optimum product within a complex hydraulic system or a whole manufacturing facility. EO2-FORM can be used for heavy duty applications like presses, EO-2 is ideal for general hydraulic and pneumatic pipework. This allows maximum total system performance with minimum component, assembly and stocking cost.
- No risk** – EO2-FORM technology is based on the proven EO-2 technology. All components and the assembly technology are approved. The customer does not have to test a new system.
- High pressure performance** – Due to the application of even better materials combined with the special processing of individual components, EO2-FORM can be used in applications of up to 800 bar (S series) and 500 bar (L series). EO2-FORM considerably exceeds the DIN/ISO requirements and guarantees a 4-fold design factor. Thanks to the higher pressure levels, less
- expensive “L” series fittings can now be used instead of the heavier “S” series, which also is a benefit in limited or tight space applications.
- Sealing capability** – The high volume elastomeric seal forms the primary sealing element, thus assuring leak-free sealing. Even low-viscosity media such as water or gas are hermetically sealed. Hydraulic systems therefore do not “sweat” at the fitting joints.
- No phantom leaks** – Lubrication is not mandatory for the assembly of steel EO weld nipples. The machine operator will not be irritated about lubricant coming out of the fittings once the hydraulic system gets hot.
- Universal** – The EO2-FORM machine can cold-form all common steel tubes used in hydraulic systems (the EO2-FORM process also allows the use of stainless steel and exotic materials such as CuNiFe; please ask for separate catalogue). EO2-FORM tools cover metric tube from 6 to 42 mm OD. Thin wall tube of 1 mm wall thickness can be formed, too.
- Vibration resistance** – The new EO2-FORM process achieves a smooth structural transformation of the tube wall allowing superior vibration resistance.
- Durability** – The elastomeric seal does not require any re-tightening even after years of operation under extreme working conditions.
- Efficient** – Compared to welding or brazing, EO2-FORM is much less time consuming. Special tube preparation and finishing are not necessary. Forming uses only a fraction of the energy needed for brazing or welding.
- Quality** – Tube clamping and tooling are fully automated. Therefore, high and consistent quality is achieved without manual adjustment.
- Noise reduction** – Compared to other forming methods, the EO2-FORM process results in a smooth inner contour of the tube that does not allow the accumulation of air, dirt or other sources of trouble. Less pressure drop, heat and noise is created.
- Re-usability** – EO2-FORM connections can be disassembled and reassembled many times. There is no wear or widening of the vulnerable fitting inner cone.
- Approved** – Both, EO-2 high pressure tube fittings and the EO2-FORM process are tested and approved by independent organisations such as Germanischer Lloyd and Det Norske Veritas (DNV).
- Small bending radii** – The compact clamping device and special dies are suitable for forming short tube ends.
- Clean** – The EO2-FORM process is environmentally clean and safe. As no heat is used, hazards from chemicals, fumes or heat do not occur.

EO weld nipple

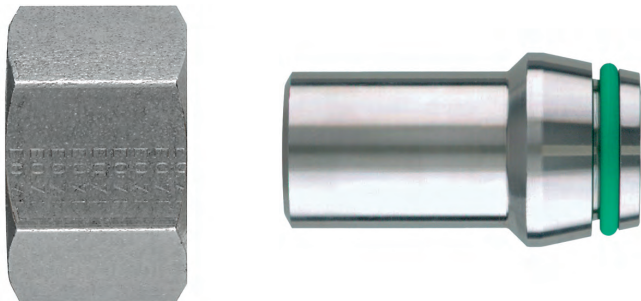

The leakfree performance of EO Weld nipples is assured by an o-ring seal.

Function of the EO weld nipple

The wide EO fitting range allows welded tube connections. Therefore, the EO weld nipple has to be welded onto the tube end.

Using the standard EO nut, this weld nipple can then be connected to the tube joint of any EO tube fitting.

EO weld nipples are available for L and S-series tubes of 6–38/42 mm diameter. A broad range of weld nipple fittings including reducers or elbows covers most applications.

The use of EO weld nipples allows remakeable pipe systems based on rigid weld connections.

Features, advantages and benefits of the EO weld nipple

EO weld nipples feature most advantages of the attractive EO fitting program. The specific benefits of the EO weld nipple program are:

- **Low quality tube** – Unlike bite-type or flared fittings, dimensional tolerances and rough tube surface are not very critical. Therefore weld nipples are suitable for countries where only poor quality tube is available.
- **Sealing capability** – An elastomeric seal forms the primary sealing element, thus assuring leakfree sealing. Even low-viscosity media such as water or gas are hermetically sealed. Hydraulic systems therefore do not “sweat” at fittings.

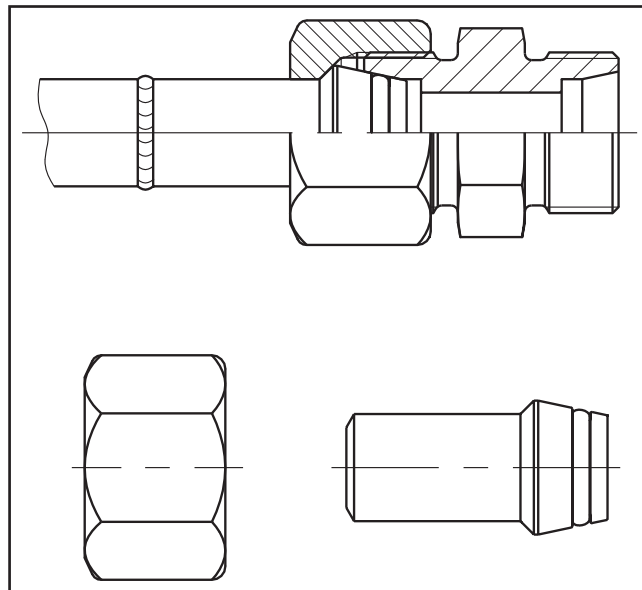

EO-Weld Nipples

- **Durability** – The O-ring seal is assembled with a high initial compression. It does not require any retightening even after years of operation under extreme working conditions.
- **Failure mode** – Unlike bite type fittings there is little danger of tube blow off if the fitting is not properly tightened. A loose joint shows excessive leakage before total failure.
- **Reusability/Remakeability** – EO weld nipples can be disassembled and reassembled many times. There is no wear or widening up of vulnerable inner fitting cone. Damaged O-rings can easily be replaced.
- **Smooth edge** – Under extreme working conditions, weld nipples are most likely to crack at the dimensional step just under the nut. In an additional rolling process this critical edge is smoothed for increased vibration strength.
- **Stress-free** – By welding, small deviations on tube cutting or bending can be compensated. Tension-free pipework is not likely to break even under extreme working conditions.
- **Welding process** – EO weld nipples are designed to be used for most popular welding processes.

Introduction to O-Lok®



The O-Lok® fitting was developed by Parker Tube Fittings Division in the USA in the early 1980's. This product has proven to be extremely effective in eliminating leaks at the higher pressures found in today's hydraulic systems.

The O-Lok® fitting is an O-ring face seal (O.R.F.S.) type fitting that consists of a nut, a body, an O-ring and a sleeve. Parker O-Lok® fittings come standard with a trapezoidal seal "Trap Seal". As shown in Fig. 1 the tube is flanged to 90° using the Parflange® system (or the tube may be brazed instead to a braze-type sleeve). When the fitting is assembled, it compresses an elastomeric seal in the precision-machined groove in the fitting body to form a leak-free connection.

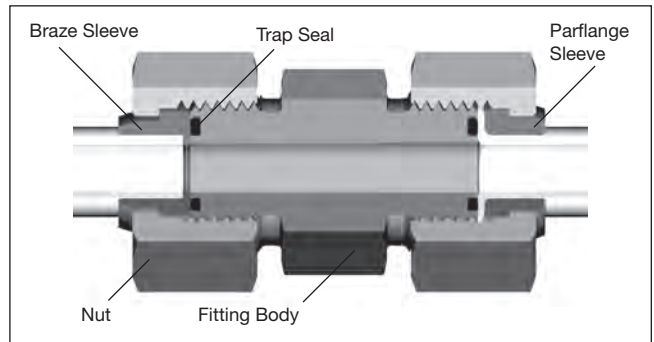

Fig. 1 – O-Lok® Union cutaway with brazed (LHS) and flanged assembly

O-Lok® fittings are suitable for a wide range of tube wall thickness and are also readily adaptable to inch or metric tubing and hose connections.

O-Lok® Progress

The last twenty years of experience supplying O-Lok® to the largest OEM customers have been well used in terms of listening to customer needs and refining design and material details to achieve the optimum mix of headline performance and a long trouble-free service life. After extensive product testing, it has been recognised that Parker O-Lok® fittings can be uprated to higher performance levels.

O-Lok®

The O-Lok® fitting system is characterised by the words.

'Durability' and 'leakfree performance'.

- **Pressure Plus** – Larger fitting sizes nominal pressure increased
 - 20 from 280 to 420 bar*
 - 24 from 280 to 350 bar*



Before tightening the nut



After tightening the nut
Standard O-Rings can be fitted instead of "Trap Seals"

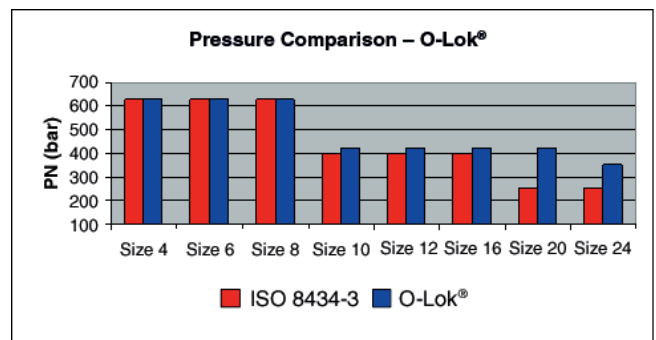

*For detailed pressure ratings see chapter C.

Function of fittings



- **Plating Plus** – 120 hours resistance to white rust corrosion exceeds the requirements of international standards.
- **Cleanliness Plus** – Contamination is the biggest source of early component failure in hydraulic systems. Parker O-Lok® fittings meet all requirements from the factory to the point of use – backed up by individual bagging.
- **CORG Plus** – All Parker O-Lok® fittings are manufactured with the Captive O-Ring Grooves (CORG) as standard. (This is an optional version in ISO 8434-3 and SAE J1453). See fig. 2.
- **Range Plus** – Parker offers the widest range of catalogue standard materials, seal combinations, styles and sizes in the industry. Only Parker has all this.

Introducing ACE Solutions

Advance Connector Enhancements are product features that take the fitting performance in the hands of customers beyond the standard we have come to expect. Driven by customer experiences and feedback from the field, ACE solutions are exactly that – simple engineering answers to real world problems.

Trap Seal

The Trap Seal in Parker O-Lok® fittings eliminates any possibility of the seal being rubbed out of position during the assembly process and hence cuts warranty costs and end customer dissatisfaction. Standard O-Rings can be dislodged without being noticed, leading to unexplained leaks after machines have been delivered to the end user. The simple patent pending engineered solution requires no changes in assembly method or order codes, and so is a seamless product upgrade unique to Parker. Existing standard O-Rings fit in the groove where necessary as field replacements.

Robust Adjustable Port Fittings

Robust Adjustable Port connections have been developed and tested to prevent leaks caused by incorrect assembly procedures. The joint geometry is re-designed to stop the backup washer being deformed / damaged if the fitting is over tightened when threaded into the port. The new robust locknut eliminates the possibilities of excessive tightening damage. It is available for all parallel thread types – UNF, Metric, BSPP. The simple design improvement leaves the assembly instructions unchanged. Patent pending.

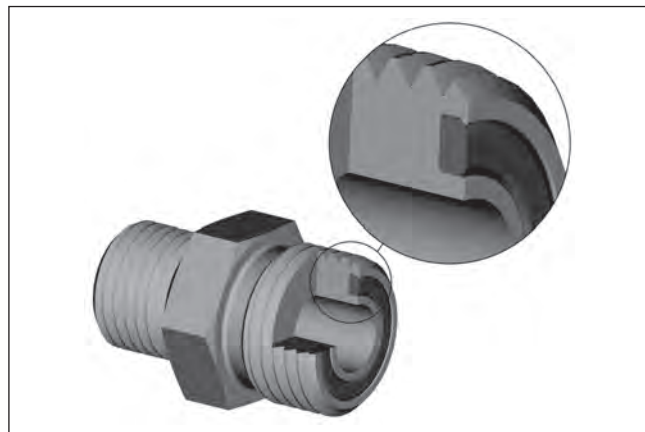

Fig 2 – Captive O-ring Groove (CORG) cutaway

Cr(VI)-free Surface finish

In accordance with European “end of vehicle life” directive 2000/53/EC which became law on 1st July 2007, all O-Lok® products have Cr(VI)-free surface protection. The new surface – introduced as a running change – gives a minimum of 120 hours to first white rust as measured according to ISO 9227 / ASTM B117 5% NaCl solution test standards.

Applications

The original development of the O-Lok® fitting was heavily influenced to meet the needs of international mobile equipment companies, mining, site clearance, agricultural and other heavy duty equipment. Today, the O-Lok® fitting is becoming an industry standard hydraulic fitting system for rugged duty equipment mounted on tracks or wheels. Equipment in these fields of application endure some of the highest levels of use, sometimes round the clock operation, in tough environments with extremes of temperature and mechanical stress. The simple, but effective design of the O-Lok® connection when used with the Parflange® tube preparation technology mean that long term ‘fit and forget’ performance is ensured, despite the physical conditions.

Simple, low torque assembly, no tube entry breakaway feature, 2”/50 mm max. tube size, and the ease of use with inch or metric tubing also make O-Lok® eminently suitable for general hydraulic applications in hydraulic presses, injection moulding equipment, shipbuilding, machine tools and a range of other areas. Anywhere in fact where a high quality leak-free tube or hose connection is needed.

Function of O-Lok® fittings

The O-Lok® fitting consists of four main components: a body, sleeve trapezoidal elastomeric seal and nut.

The O-Lok® fitting body

There are over 40 different body configurations to choose from for specific applications. The body face has a groove, which contains a high durometer seal that is held captive during installation. In addition, the O-Lok® fitting body shapes are all forged for added strength and longer service life.

Straight fittings are made from cold drawn barstock. The cold drawing process ensures consistent dimensional tolerances, improved strength and consistent surface finish.

CORG Groove

O-Lok® fittings are manufactured with a Captive seal Groove (CORG) design for prevention of seal fall out prior to final assembly. The international standards for ORFS fittings contain two versions of the seal groove. The original design had straight sides and under certain conditions of tolerance between the seal and the groove, it was possible for the seal to be dislodged. As a further refinement of the O-Lok® fitting, Parker introduced the CORG groove as standard production in all its plants in 1998.

Elastomeric Sealing

From the design of the system, the Trap Seal compression gives excellent sealing characteristics from low pressure, low temperature circumstances found in winter during machine storage, to full pressure, high temperature cycles. Trap Seals are made from the same high quality NBR compound as the O-Rings superseded in 2006.

The O-Lok® fitting nut

Smaller size O-Lok® fitting nuts are cold-formed to provide a more tightly packed grain structure, resulting in a much stronger component. Larger size nuts are made of warm-forged steel-blanks.

The O-Lok® Parflange® sleeve

The preferred method of making an O-Lok® tube connection is by using the Parker Parflange® process to create the 90° flange on the tube end. A flange sleeve is used to support the flange and the tube, and provides the contact shoulder for the nut. After the Parflange® process, the sleeve is permanently fixed on the end of the tube reinforcing the joint.

The O-Lok® connection using the Parflange® method can be made with either metric or inch tubing by choosing the appropriate sleeves and tooling.

Parflange® sleeves from Parker are manufactured to exacting tolerances and geometry to work with the Parflange® machine and tooling, producing the robust, reinforced tube end connection. Failure to use the correct components can result in premature joint failure in the final application.

The O-Lok® braze sleeve

The braze sleeve provides the mating surface between the tube and the fitting body. Secondly, the braze sleeve, as the name implies, is attached to the tube through silver brazing. The braze provides holding power as well as a method to seal the joint. It also has a flat and smooth contact shoulder for the nut to connect the tube to the fitting body.

O-Lok® braze sleeves are manufactured to exacting dimensions. Tightly toleranced dimensions are required to prevent binding in the nut when torqued, to provide a flat and smooth sealing surface against the seal, and to give the appropriate clearance for silver brazing to the tube.

The O-Lok® connection can be made with either metric or inch tubing by choosing the appropriate braze sleeve.

The O-Lok® reducing braze sleeves

O-Lok® braze sleeves are manufactured in both even and reducing sizes. The reducing sleeves make it easy to adapt a larger face seal fitting to a smaller tube connection.

O-Lok® fitting function

The O-Lok® fitting body face contains a high durometer seal that is held captive in a precision machined groove. As the nut is tightened onto the fitting body, the seal is compressed between the body and flat face of the tube flange or braze sleeve to form a tight, positive seal.

As the two faces come in contact, further tightening of the nut produces a sharp rise in assembly torque. A solid pull of the wrench at this point, to the recommended assembly torque, completes the assembly.

The sharp torque rise gives a “solid feel” at assembly, and minimises the possibility of over tightening.

Because the sealing surfaces are flat and perpendicular to the assembly forces, they remain virtually free of distortion during assembly, giving O-Lok® fittings virtually unlimited remakeability. The seal should be inspected at each disassembly and replaced when necessary.

Parflange® orbital flaring process

The Parflange® process

With the Parflange® process, the tube to sleeve attachment is achieved mechanically during an orbital cold forming process with a Parflange® machine. The process progressively flares then flanges the tube. The final dwell action in the cycle ensures that the seal surface produced is smooth and flat, and also eliminates spring-back effects in the material. This flange provides both the holding power and sealing surface (eliminating the braze joint, and hence, a potential leak path found with brazed sleeve attachment). The only sealing point is between the fitting body and the tube flange face via the high durometer elastomeric seal. Trap Seals are now fitted as standard to Parker O-Lok® fittings.

The flanging process is very fast and requires very little cleaning prior to or after flanging. Thus, the process enhances the integrity of the joint and reduces cost.



Parflange® 1025

The Parflange® process utilises an orbital cold flow forming process to produce a flat, smooth, rigidly supported 90° sealing surface on the tube end. The process progressively flares then flanges the tube.

The Parflange® process conforms to the requirements for mechanical tube forming shown in the SAE J1453 standard, and has been specified after extensive testing by the majority of the large mobile equipment manufacturers.



Upgraded Parflange® 50 – Easier to use, reliable machine

Flanging with Parflange® eliminates the need for welding or brazing of the sleeve to the tube end.

Parflange® 50 series production machine

The 50 generation of the hugely successful Parflange® machine incorporates all the feedback and suggestions from professional tube manipulation users across the world. Ergonomics, controls and electronics and maintenance aspects are all improved, but the heart of the process – the Parflange® orbital forming head remains unchanged. Similarly existing tooling can be used with the new machine, making a 50 upgrade from the 1040 generation a seamless experience. For full details please see chapter H.

Parflange® advantages over brazing or welding

- **Flexibility** – Fast tool changes and easy set-up make small batches economical to reduce WIP (work in progress) and inventory costs.



Parflange® tools

- **Faster** – 9 to 12 times the speed of comparable induction brazing.
- **Simple tube preparation** – The Parflange® process does not require any special pre- or post-flange cleaning of the tube and sleeve. The process is simple and the machine requires straightforward training only to operate.
- **Safety** – Unlike brazing, the Parflange® process does not require any flux, braze alloy, post braze cleaner or rust inhibitor. An environmentally safe lubricant applied to the flanging pin is the only additive associated with the Parflange®.

The Parflange® process



For O-Lok®, the sleeve is placed into clamping dies first



Tube is inserted into the tools until it firmly touches the stop at the end



After starting the process, the dies clamp the tube and the flanging pin starts the orbital movement and the forward stroke



While moving, the front pin expands the tube wall from the inside

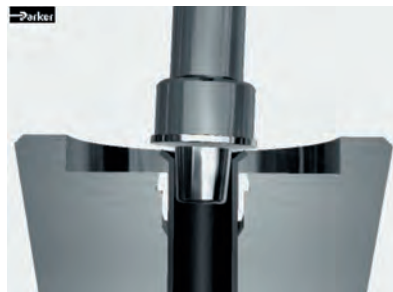

As soon as the flat working surface of the pin contacts the tube end, the flanging process begins



The front surface is continuously rolled and compressed. From the inside, the tube surface is slightly expanded to clamp the sleeve



As soon as the defined flange contour is achieved, the orbital movement stops and the pin withdraws

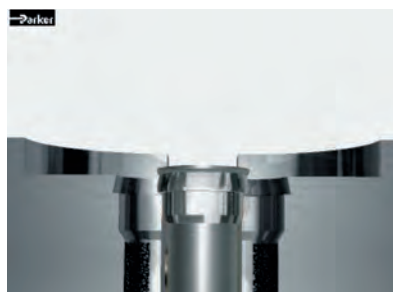

The tube end is released and can be taken out of the machine



The connection is ready for assembly

Function of fittings

- **Environment** – The Parflange® process is environmentally clean and safe. It does not require open flame or any form of heating. Additionally, there is no emission of hazardous fumes, as is typical with welding and brazing.
- **Energy** – The Parflange® process uses only a fraction of the energy needed for welding or brazing.
- **Corrosion resistance** – The Parflange® process accommodates the use of plated or unplated components (i.e. tube and sleeve). Thus, the high costs of electroplating assemblies after fabrication is eliminated by using pre-plated tube.
- **Excellent surface quality** – The Parflange® process eliminates the potential leak path present at the braze or weld joint. The Parflange® process produces a burnished sealing surface, typically much smoother than the 3.1 µm/125 micro-inch Ra surface smoothness requirement of SAE J1453.

Users of Parflange® and Parker's O-Lok® fittings enjoy all the inherent sealing, reliability, time and cost saving benefits, without the many drawbacks which accompany welding or brazing.

Therefore, Parker strongly recommends the Parflange® process for the assembly of Triple-Lok® and O-Lok® connections. Parflange® machines range from desktop 1025 for flexible workshop use to Parflange® 50 for economic industrial production.

Features, advantages and benefits of the Parflange® process for Triple-Lok®, O-Lok®

- **Superior sealing performance** – The Parflange® process achieves a sealing surface of unique surface quality and mechanical strength.
- **Superior vibration resistance** – Unlike conventional flaring, the Parflange® process results in a rigid connection of the O-Lok® sleeve on the tube-end. Parflange®/O-Lok® connections perform much better under reversed bending stress conditions.
- **Easy to use** – No programming or adjustments necessary. High quality results are consistently achieved without manual adjustment.
- **Cost saving** – Compared to brazing or welding, orbital flanging is much less time consuming. Special tube preparation and finishing are not necessary. Flanging uses only a fraction of the energy needed for brazing or welding. In summary the Parflange® process can reduce costs for volume manufacture by more than half.
- **Clean** – The Parflange® process is environmental clean and safe. As no heat or chemicals are used, hazards from fumes or heat do not occur.
- **Zinc plated tubing** – The Parflange® process allows the use of zinc-plated tubing. The cost for cleaning, post process plating or painting can be saved.
- **Process/Product concept** – Parflange® machines are specially designed to match Parker O-Lok® and Triple-Lok® standards. Machine, tools and products are fine-tuned for reliable performance.
- **Proven technology** – For more than 14 years, hundreds of Parflange® machines have operated worldwide under heavy duty workshop conditions.

Introduction to Triple-Lok®



The concept of flaring tube to provide a seal and holding power to the connection is very old. It's origin goes back to the early days of the automobile. Different types of flared connections including 45° single and double flares, inverted flare, 30° flare, etc., were developed for coolant, fuel, brake and lube systems of the early automobile.

Pioneered by Parker Hannifin, the Triple-Lok® 37° flared fitting evolved as a higher pressure version of the above connections. Its initial use was in the developing hydraulic systems of agricultural and earth moving machinery, automotive transfer lines and other machine tools.

As exports of machinery increased after World War II, the Triple-Lok® Plus fitting gained worldwide use and acceptance. Today it is the most widely used fitting in the world.



Before tightening the nut

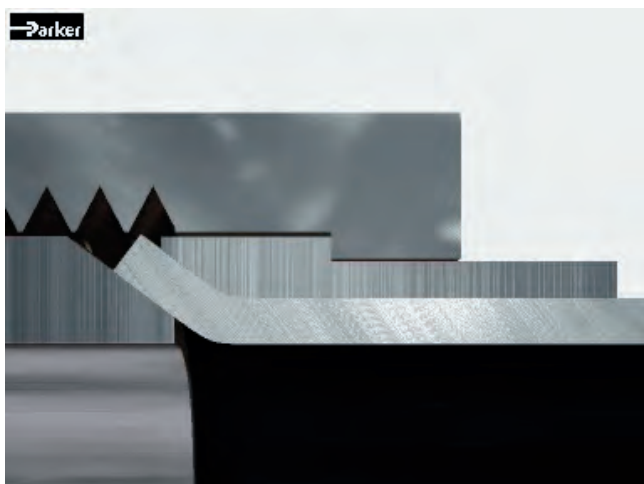

After tightening the nut

It enjoys conformance approvals by a range of national and international technical and certifying organisations.

Its appeal is in its simplicity, compact design, ease of assembly, reliability (single sealing point), wide availability and acceptance. It is especially suited for low and medium wall thickness tubing. Today the Triple-Lok® generation capabilities range from 500 bar for smaller sizes to 140 bar for largest – 2" size. Currently it is used in virtually every application that uses fluid power for motion control.

Triple-Lok® Progress

Parker have supplied more Triple-Lok® fittings than any other manufacturer over the last seventy years. Parker engineers take a leading position in advising both customers and the international standards committees concerning 37° flare fittings. This experience, combined with optimised manufacturing methods and materials have resulted in steady product performance improvements verified by extensive testing in the laboratory. A combination of simple burst tests (with a 4× design factor), impulse and vibration tests have shown Parker Triple-Lok® fittings can be uprated to higher performance levels in the smaller and in the larger sized parts. Additionally, the corrosion protection level has been improved by 100% due to effective process control.

Triple-Lok®

The Triple-Lok® fitting can be characterised by the phrase "reliable product performance".

- Pressure Plus** – Following fitting sizes nominal pressure increased
 - Size 4: 350 ISO 8434-2 (bar) 500 Triple-Lok® (bar)
 - Size 5: 350 ISO 8434-2 (bar) 420 Triple-Lok® (bar)
 - Size 6: 350 ISO 8434-2 (bar) 420 Triple-Lok® (bar)
 - Size 8: 350 ISO 8434-2 (bar) 420 Triple-Lok® (bar)
 - Size 20: 210 ISO 8434-2 (bar) 280 Triple-Lok® (bar)
 - Size 24: 140 ISO 8434-2 (bar) 210 Triple-Lok® (bar)
 - Size 32: 105 ISO 8434-2 (bar) 140 Triple-Lok® (bar)

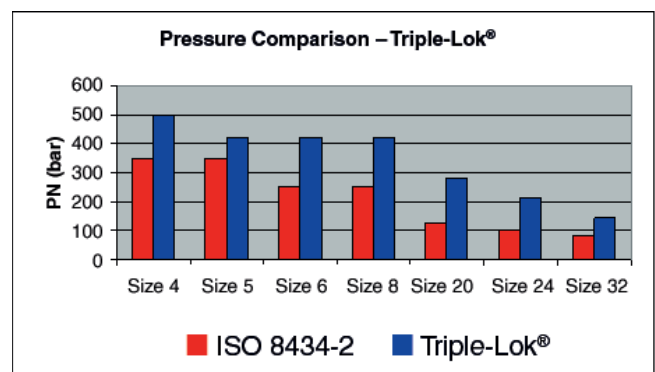

Function of fittings



Fig. C1 – Assembled Triple-Lok® fitting cutaway and Triple-Lok® fitting components (fitting body with O-ring, sleeve and nut).

- **Plating Plus** – 120 hours resistance to white rust corrosion exceeds the requirements of international standards.
- **Cleanliness Plus** – Contamination is the biggest source of early component failure in hydraulic systems. Parker Triple-Lok® fittings meet all requirements from the factory to the point of use – backed up by individual bagging.
- **Range Plus** – Parker offers the widest range of catalogue standard materials, seal combinations, styles and sizes in the industry. Only Parker has all this.

This all adds up to an unbeatable combination of performance and customer-friendly features.

Introducing ACE Solutions

Advance Connector Enhancements are product features that take the fitting performance in the hands of customers beyond the standard we have come to expect. Driven by customer experiences and feedback from the field, ACE solutions are exactly that – simple engineering answers to real world problems.

- **Robust Adjustable Port Fittings**

Robust Adjustable Port connections have been developed and tested to prevent leaks caused by incorrect assembly procedures. The joint geometry is re-designed to stop the backup washer being deformed / damaged if the fitting is over tightened when threaded into the port. The new robust locknut eliminates the possibilities of excessive tightening damage. It is available for all parallel thread types – UNF, Metric, BSPP. The simple design improvement leaves the assembly instructions unchanged.

- **Cr(VI)-free Surface finish**

In accordance with European “end of vehicle life” directive 2000/53/EC which became law on 1st July 2007, all

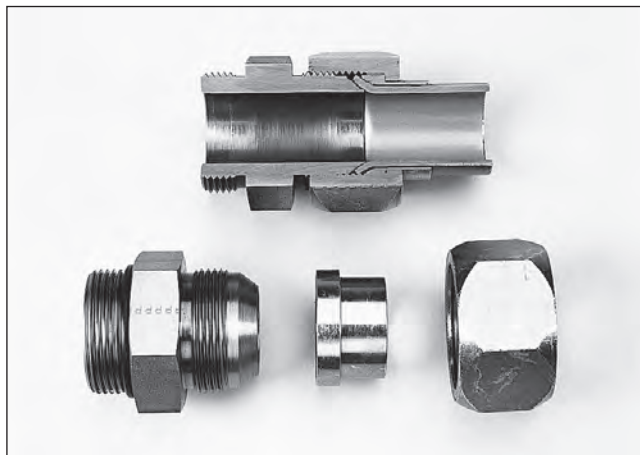

Fig. C2

Triple-Lok® products have Cr(VI)-free surface protection. The new surface – introduced as a running change – gives a minimum of 120 hours to first white rust as measured according to ISO 9227 / ASTM B117 5% NaCl solution test standards.

- **Dual Angle Swivel Connections**

In another ‘first’ for Parker, all swivel female cone connections will be switched to the unique dual angle design. This will make the connections even more effective by increasing the reliability in dynamic pressure conditions, making the contact point between the cones more stable, and easier to make a tight connection when the sealing cone gets damaged. Further, the pressure rating for some of the connections will be increased, without the need for heavier or higher strength materials. Another elegant engineering upgrade from Parker. There are no changes to the assembly procedures or part numbers. Customers need do nothing to start to receive a superior product.

Applications

Because of its long history and the heavy influence of American industry worldwide, Triple-Lok® fittings designed to the original American SAE standard are found in almost every branch of hydraulics, from garbage trucks to shipbuilding. They are particularly prevalent in those branches of mobile hydraulics where medium pressure systems are used. The Triple-Lok® fitting system is especially applicable where high volumes of tubes are prepared, and efficient tube flaring equipment can be employed. Still field repairs can be made with hand tools where needed.

Function of Triple-Lok® fittings

The Triple-Lok® fitting design is very simple. It uses an easily produced flare at the tube end to seal and hold fluid under high pressure. The fitting consists of three pieces: the body, sleeve and nut. The tube end is flared to a 37°

angle and held between the fitting nose (seat) and the sleeve (support) with the nut as shown in Fig. C1, providing a very effective single seal point between the fitting nose and the tube flare.

The support sleeve serves several important functions:

- It provides a clamping surface against the rear of the tube flare and a bearing shoulder for the nut. This minimises tube twisting during assembly.
- It provides support to the tube flare. The tapered fitting nose tends to wedge open the flare during assembly. The sleeve helps to resist this expansion, allowing the fitting to be tightened adequately.
- It makes the fitting adaptable to both metric and inch O.D. tubing merely by changing the sleeve. This feature has made Triple-Lok® fittings accepted worldwide.

The Triple-Lok® design is also very efficient. It has the smallest seal area of all fitting designs. The seal area is only slightly larger than the fluid flow area. The small seal area results in compactness and low assembly torque compared to the holding power of the joint.

The design was standardised initially as a J.I.C. (Joint Industrial Council) design and was later adopted by the S.A.E. (Society of Automotive Engineers) and I.S.O. (International Organisation for Standardisation) to assure complete dimensional interchangeability between various manufacturers.

Even though many manufacturers conform to the same dimensional standard, there are significant differences in actual performance of the fittings because of a variety of methods of manufacture and quality standards used.

Triple-Lok® fitting components are produced using the best methods of manufacture and state of the art equipment to assure construction integrity, high strength, long service life and high quality.

The Triple-Lok® body – Straight bodies are made from either cold drawn bar stock, or cold-formed construction. All shapes are of one-piece forged construction eliminating potential leak paths of multiple component constructions such as brazed shapes. The Triple-Lok® steel forged shapes also feature higher hardness for high pressure capability and minimising nose collapse (typical of sizes – 10 and under) during repeated assembly. This compares very favourably to parts of brazed construction, which typically exhibit lower hardness and hence much more nose deformation.

The Triple-Lok® sleeve – Triple-Lok® fitting support sleeves are cold-formed and heat treated for an optimum combination of strength and ductility. Cold forming also eliminates the problems of laps, folds, stringers, etc., associated with sleeves machined from bar stock.

The Triple-Lok® nut – Nuts for all but the three largest sizes (–20, –24 and –32) are cold formed. Cold forming increases material strength and its fatigue properties, imparting high strength and longer service life to the nuts.

Larger nuts which are less severely stressed, are hot forged.

Triple-Lok® fittings sealing function

As seen in Fig. C2, tightening of the nut clamps the tube flare against the body nose, producing a leak tight joint. This clamping onto the 37° cone provides a measure of elasticity to the joint helping it to resist loosening under vibration. The clamping force results in a radial load (F_R) that tends to deform the fitting nose inwards. The resistance of the nose to elastic deformation provides a constant pre-load (similar to a spring washer) keeping it tight.

The clamping force provided by the nut resists the opposing force of the fluid under pressure. The joint remains leak tight as long as the clamping force is higher than the opposing pressure load. Properly assembled Triple-Lok® fittings with appropriate tube will seal consistently under pressure until the tube bursts.

Sealing in Triple-Lok® fittings takes place between two smooth metal surfaces, the fitting nose and inside of the tube flare. Therefore, the sealing surfaces have to be round and smooth, free of any, scratches, dents, spiral tool marks, splits or weld beads, in the seal area.

Seamless or welded and redrawn fully annealed tubing is recommended for Triple-Lok® fittings for ease of flaring and tube bending.

Features, advantages and benefits

- **Pressure** – Triple-Lok® fittings are rated up to 500 bar nominal pressure with 4× design factor. Triple-Lok® can be used in more applications.
- **Robust Adjustable Port connections** – Eliminates potential assembly errors associated with over tightening of the elbow or tee bodies into ports. Reduces warranty claims from unseen assembly faults.
- **Cr(VI)-free surface** – Triple-Lok® fittings conform to the requirements of the European directive 2000/53/EC.
- **Corrosion resistance** – Triple-Lok® fittings achieve a minimum of 120 hours to first white rust, exceeding industry standards.
- **Dual Angle Swivel** – improved reliability in dynamic pressure conditions and increased pressure ratings for the swivel connection.

Function of fittings

- **Safety** – The flared tube provides a solid and visible stop for the nut. The tube flare means there is no risk of tear out of the tube, thus giving the Triple-Lok® system a reputation for safety.
- **Single seal point** – Triple-Lok® fittings have only one seal (between the fitting nose and flare I.D.). This makes a highly reliable joint that is easily maintained.
- **Easy to assemble** – Small seal area under pressure makes for high-pressure capability at relatively low torque levels. This allows the use of small wrenches for easy installation and maintenance.
- **Wide temperature and media compatibility** – Metal to metal seal allows a range of uses and many applications.
- **Tube materials** – Triple-Lok® fittings can be used with most tube materials, such as high and low-grade steel or stainless steel, copper and aluminium.
- **No minimum tube wall limitation** – Triple-Lok® fittings are suitable for very thin to medium wall tubing. The optimum wall thickness tubing can be used, reducing overall system cost.
- **Ease of installation and maintenance** – Short tube entry means that installation is simplified and minimum tube prying is necessary when maintenance is required on the system. It is easy and quick.
- **Adaptability to metric & inch tubing** – Triple-Lok® fitting sleeves make the system suitable for inch and metric tubing by merely changing the sleeve.
- **Adaptability to hose assembly** – Triple-Lok® fittings allow for direct connection to 37° flare hose assemblies, the most popular industrial hose connection worldwide.
- **Forged shapes** – Triple-Lok® fittings have no braze joints to leak. Forgings provide higher dependability and longer life compared to multiple component brazed constructions.
- **Hard forgings** – High hardness of Triple-Lok® fittings forged shapes minimises the deformation of the 37° nose during assembly, maintaining full flow area and good reuseability.
- **Cold formed sleeves and nuts** – Sleeves and nuts in popular sizes are cold formed for high strength and toughness through optimum grain flow. This imparts high dependability and long service life.
- **International standard design** – Triple-Lok® fittings offer worldwide availability and interchangeability, they conform to SAE and ISO standards. 37° fittings are the most widely used fitting type in the world.
- **Availability** – Triple-Lok® fittings offer the broadest range of sizes and configurations of any fitting. This provides users with the optimum choice of tube fitting options. Standard materials offered are steel, stainless steel and brass.

Adapters – introduction

In addition to the tube fittings described earlier, there are needs for other adapters to complete hydraulic circuits which perform different functions:

- **Thread size adapters** – to reduce or expand the existing thread
- **Thread conversion adapters** – to change from one port thread to another to allow tube fitting or hose connections
- **Hose end adapters** – hose to port, hose to hose etc.
- Blanking plugs.

The range of Tube Fittings products, when used without the tube nut and ring/sleeve, can also be used as hose adapters to allow the corresponding hose assembly to connect to a port.

Adapters are frequently used in maintenance situations, where equipment is used outside the region in which it was manufactured. For example to convert BSPP threads from a European manufacturer to an American thread alternative – UNF or NPT. Adapters are therefore often the most economical way to solve short-term problems.

There are many types of threads used in the Fluid Power industry throughout the world. This section contains adapters with a wide range of those thread types including: NPT, NPTF, NPSM, BSPT, BSPP, SAE, UN/UNF, and Metric. All threads in this section are made to industry specifications with conformance shown in Table F1.

Thread	Standard
NPT	ANSI B1.21.1, FED-STD-H28/7
NPTF	SAE J476, ANSI B1.20.3, FED-STD-H28/8
NPSM	ANSI B1.20.1, FED-STD-28/7
BSPT	BS 21, ISO 7/1
BSPP	BS 2779, ISO 228/1
Metric	ISO 261, ANSI B1.13M, FED-STD-H28/21
UN/UNF*	ANSI B1.1, FED-STD-H28/2

Table F1 – Thread conformance standards

Adapters from Parker Hannifin are manufactured from drawn barstock for straight parts, or from forgings in the case of elbows, tees and crosses, to give higher durability and long term performance. Pressure ratings are based on the same requirements used for the tube fittings product ranges. Parts are corrosion protected also to the same high standard found in other High Pressure Connectors Division products.

Adapters – function

NPT/NPTF adapters

Commonly known as pipe thread adapters in USA, NPT and NPTF (Dryseal) adapters have tapered threads. These threads feature a 60° flank angle and 1°47' taper, as shown in Fig. F1. Because of the taper, they are commonly used in the USA as adjustable fittings in the elbow and tee forms. It has been found that although NPT/NPTF have a high static pressure capability, they are unreliable in dynamic applications, especially in the larger thread sizes 1" and above. Parker therefore recommends the use of alternative thread forms and sealing, based on elastomeric seals for new applications and designs.

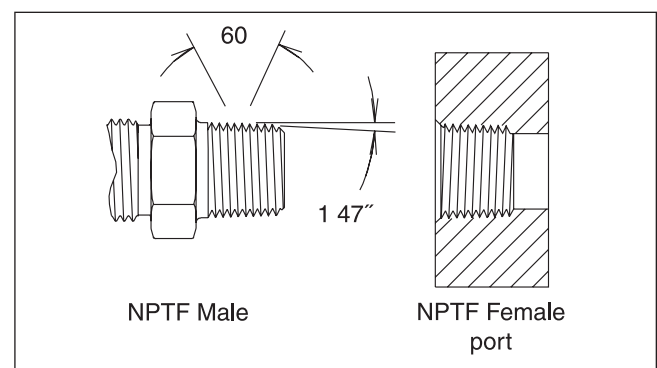

Fig. 1 – NPTF thread

NPT threads when assembled without a sealant, leave a spiral leak path at the crest-root junction as shown in Fig. F2. To seal pressurised fluid, NPT threads need a suitable sealer.

NPTF threads (Dryseal) on the other hand, when assembled, do not leave such spiral leak path. This is because they have controlled truncation at the crest and root, ensuring metal to metal crest-root contact as the male-female thread flanks make contact as seen in Fig. F3. Upon further tightening, the thread crests are flattened out until the flanks also make metal to metal contact as seen in Fig. F4. Theoretically, at least, there is no passage left for the fluid to leak, provided all surfaces are flawless and dimensions exact. In the real world, however, this is not the case and a sealant/lubricant is necessary to achieve a leak free joint even with NPTF threads. Because of the higher surface pressure contact with the NPTF design, Parker manufactures all Stainless steel adapters with the NPT thread form to reduce the possibility of thread galling (Cold welding effects).

Function of fittings

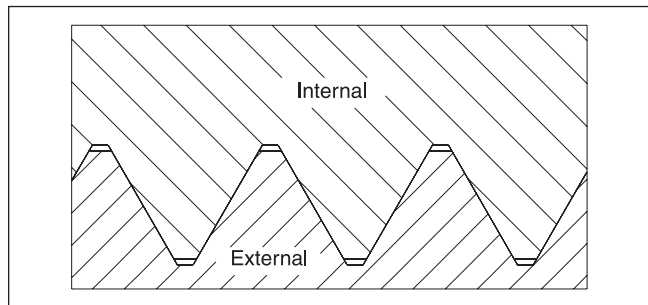

Fig. 2 – NPT – Wrench tight – No Crest-Root contact, Flank contact only.

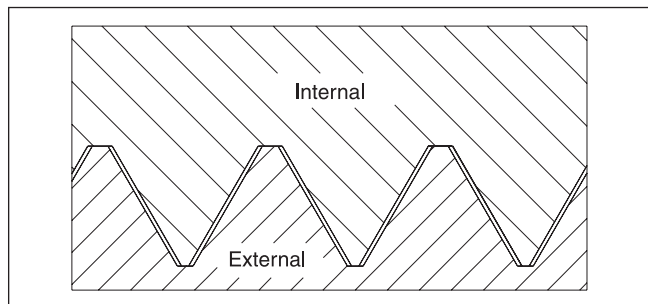

Fig. 3 – NPTF – Hand tight crest-root contact

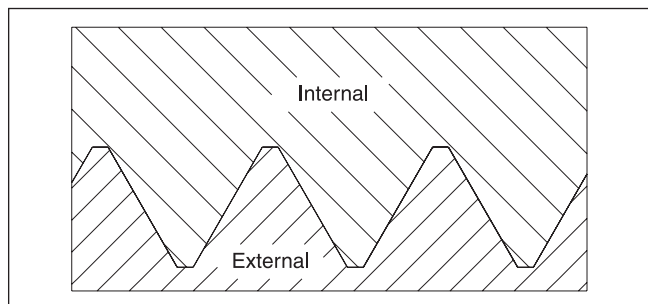

Fig. 4 – NPTF – Wrench tight crest-root and flank contact

Type of sealant/lubricant

Sealant/Lubricant assist in sealing and provide lubrication during assembly, reducing the potential for galling. Pipe thread sealants are available in various forms such as dry pre-applied, tape, paste and anaerobic liquid. PTFE tape, if not applied properly, can contribute to system contamination during assembly and disassembly. Paste sealants can also contribute to system contamination, if not applied properly. They are also messy to work with, and some types require a cure period after component installation, prior to system start up.

BSPT adapters

BSPT threads came from the British gas industry, where the outside diameter of a gas pipe was threaded at the end to allow a connection to be made. The thread form has a 55 degree flank angle, and the thread pitch is dif-

ferent generally to NPT threads. Therefore the two forms are not compatible. Today the BSPT thread is used in the pneumatics industry, but use on the hydraulics side is limited. In most cases, the BSPT male stud is screwed into a BSPP – parallel – port. Thread engagement in this situation is limited, giving lower holding power compared to NPT equivalents.

To seal BSPT threads, a sealant is always needed, since the sealing function is on the threads. BSPT fittings offer a limited adjustability when using elbow or tee types, and it is easy to overtighten and damage the port thread, stud thread or both. Re-useability is also therefore very limited. For all these reasons, BSPT threads should be limited to lower pressure applications with limited dynamic changes in pressure. Parker Hannifin does not use BSPT threads in it's "Dry Technology" programmes for this reason.

UNF thread adapters

Function of UNF adapters

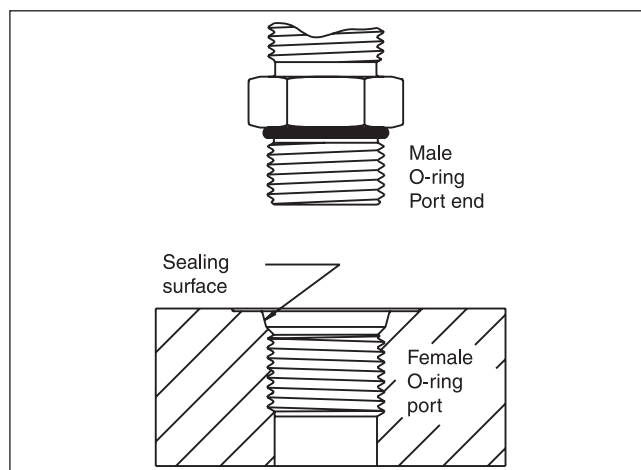

Fig. 5 – UNF port

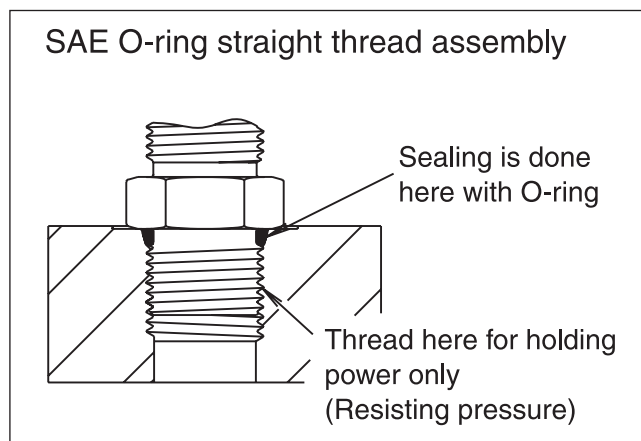

Fig. 6 – UNF port assembly

Parker fittings incorporating UN/UNF thread, O-ring port studs shown in this section are for connection with the UN/UNF thread ports. They are also known as O-Ring Boss (O.R.B.) connections. When properly assembled, they give performance equal to the best leak-free port connection available.

For this style of connection, the sealing and holding functions are separated. The threads have only the holding function. Thread tolerances are wider between the male stud and female port, and so the sensitivity to damage of the threads is much lower than the NPT for example. Sealing is achieved via a high durometer O-ring seal seated in a specially machined chamfer at the top of the port thread. When energised under pressure, the O-ring seals the only leak path. Good initial compression of the seal, means that the joint is leak tight at low and high pressures.

Features, advantages and benefits

SAE straight thread

- **Elastomeric seal** – SAE straight thread O-ring connections offer a high sealing reliability, especially in dynamic and shock loading applications. The O-ring seal offers a high tolerance to minor surface imperfections and damage.
- **Ease of assembly** – This design is extremely easy to assemble, even for less experienced workers.
- **Infinite positioning of shaped fittings** – Due to the design of shaped fittings, incorporating adjustable SAE straight thread connections, they allow for infinite positioning of the port end. Aligning for tube and hose connections is much easier as compared to tapered threads.
- **Reusability** – Since the sealing and mechanical holding functions are separated, the SAE straight thread male studs can be re-used many times simply by changing the O-ring.

ISO 6149 adapters

The ISO 6149 connection design is similar to the UN/UNF, but with metric threads. The pressure performance of the connections is therefore similar, and also the user-friendly assembly characteristics. This design is recommended by the ISO standards committee for all new applications and designs. The ISO 6149 thread has gained widespread use with OEM's in the agricultural and construction equipment segments. Parker Hannifin offers one of the widest range of tube fittings and adapters to the ISO6149 standard.

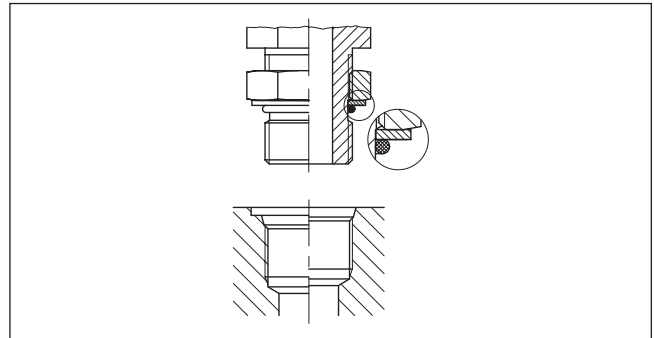

Fig. 7 – Adjustable UNF Port connection

Japanese Industrial Standard (JIS) adapters

JIS adapters are typically used as hose adapters on equipment designed or built in Japan or Korea. Sealing is achieved with a line contact between the surfaces of mating 60 degree cones on the fitting and the hose end. These adapters are made according to the JIS B8363 standard. Although they have the same cone angle and threads as the BSPP 60 degree cone adapters below, they are not interchangeable. (Longer thread lengths on the JIS female swivel fittings lead to threads bottoming out before the seal is made on the corresponding BSPP fitting).

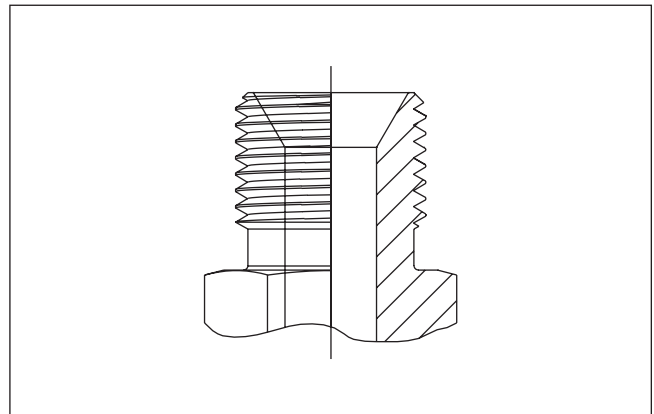

Fig. 8 – JIS adapter

BSPP thread adapters

British Standard Pipe (Parallel) threads are still the most widely type used today in the Fluid Power Industry in Europe. This section is split into two parts, covering the thread adapters and later the BSP hose adapters.

Function of 60 Deg cone

This form of BSPP adapter which has been modified to work as a hose adapter is still popular in the UK, Scandinavia and throughout the rest of Europe. These connections are standardised in BS5200. The bore of the BSPP thread is coned inwards with a 60 degree includ-

Function of fittings

ed angle to match with a male cone of the same angle on a Swivel Female hose end see figure 9 below. When the nut is tightened, the two cone halves are clamped together to form a metallic seal. This type of connection is flexible in use, since the same thread end could also be used to screw into a BSPP threaded port.

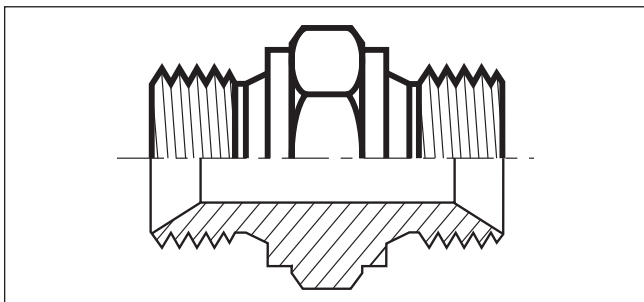

Fig. 9 – BSPP 60° cone adapter

Despite this flexibility, these adapters cannot be used as tube fittings in the same way as Triple-Lok®, O-Lok® or EO fittings, and therefore cannot be classed as a “universal system”.

Many manufacturers produce the elbow and tee adapters by brazing together straight parts. This can result in the fitting being effectively annealed during the brazing process, and therefore the material is left in its softest state. Parker tees and elbows are manufactured from high integrity forgings and offer superior long term performance.

Function of BSPP thread adapters

BSPP thread adapters are designed to work with ports that have been machined with a flat ‘spot face’ concentrically around the thread. This spot face provides a consistent flat sealing area, whether the port is in a machined valve block, or on the face of a pump housing casting. Originally, the sealing was in the form of a copper (or other ductile metal) washer, but today most adapters use some form of elastomeric seal.

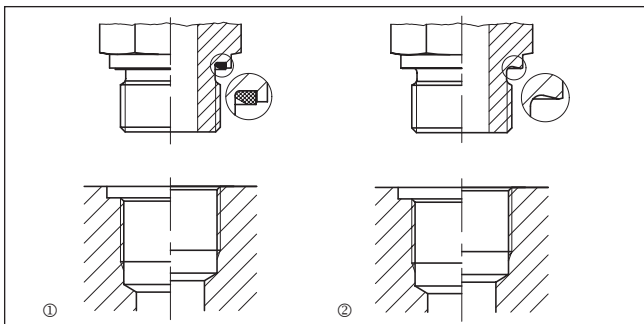

Fig. 10 – ①ED-seal; ② Form B

The highest performance is achieved by the ED seal version, followed by the O-ring and retainer ring, bonded washer and lastly the German “Form-B” metallic sealed design. In terms of adjustable fittings, they are only normally available in the O-ring and retainer version. The ED seal design does not lend itself to adjustability.

Metric thread adapters

Metric thread adapters have developed in parallel with the BSPP threaded adapters with a similar design based around the metric thread sizes.

Pipe (NPSM) swivel adapters

Function of NPSM swivels

NPSM swivel adapters are designed for use with male NPT/NPTF hose fittings that have a 30° machined seat. NPSM adapters do not seal on the threads like most NPT thread adapters, they seal on the nose of the NPSM swivel and the seat on the male NPT/NPTF pipe thread. This creates a metal to metal seal as shown in Fig. 11. The most important preparation prior to assembly is to make certain that the mating male NPT/NPTF pipe thread has a 30° seat as shown in Fig. 12.

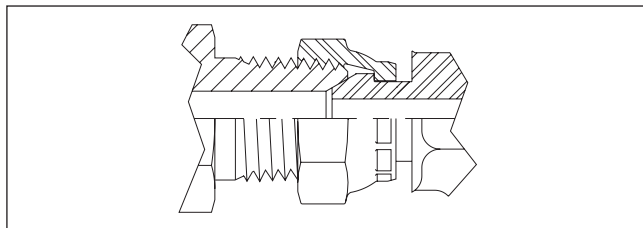

Fig. 11 – Illustration showing how NPSM swivel adapters seal on mating chamfer in male NPT thread

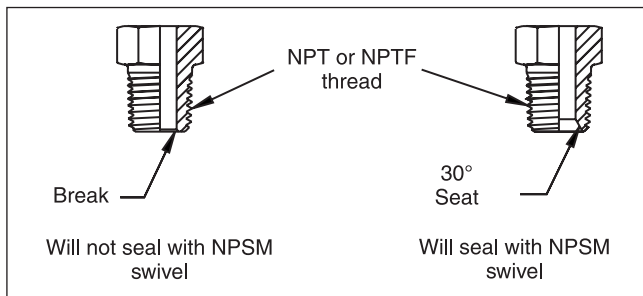

Fig. 12 – Illustration showing the required 30° seat on NPT/NPTF threads for NPSM swivel to seal

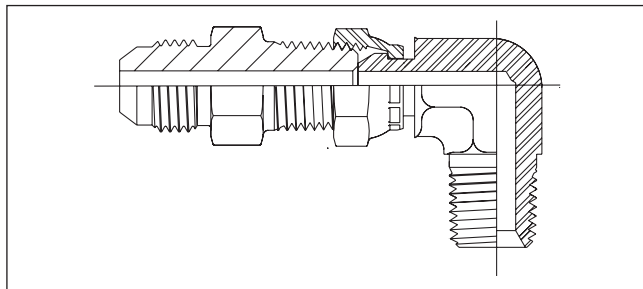

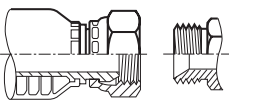
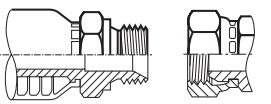
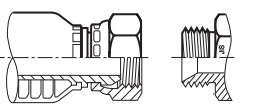
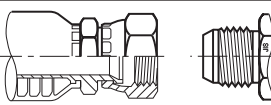
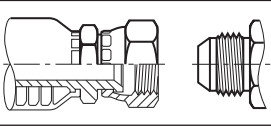
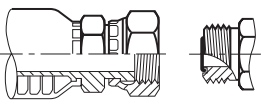
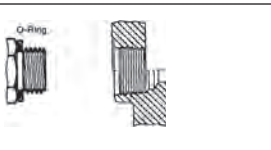
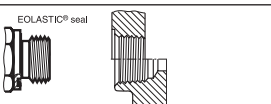
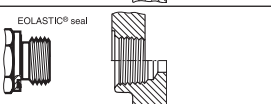
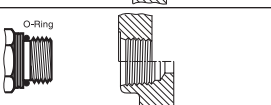
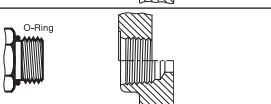
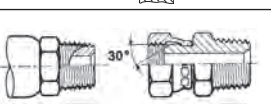

Fig. 13 – Chamfer of NPT/NPTF male thread does not provide appropriate contact for a reliable seal with cone of NPSM swivel

Thread configurations

Taper thread adapters NPTF and		NPTF thread SAE J476-B2
BSPT		BSPT taper thread ISO 7
BSPP 60° cone adapters		BSPP male parallel thread 60° female cone BS5200
		BSPP female parallel thread 60° male cone BS5200
JIS adapters		BSPP male parallel thread JIS B8363 60° female cone
		BSPP female parallel thread JIS B8363 60° male cone
37° Flare (Triple-Lok®) and		SAE 37° Flare UNF thread SAE J514 ISO 8434-2
ORFS (O-Lok®) adapters		ORFS (O-ring Face Seal) UNF thread SAE J1453 ISO 8434-3
Male studs and female port threads		BSPP parallel thread O-ring and retaining ring according to ISO 1179
		BSPP parallel thread with ED seal according to ISO 1179-2
		Metric parallel thread with ED seal according to ISO 9974-2
		Metric straight thread ISO 6149-2+3
		UN/UNF threads SAE J475 thread ISO 11926-2/-3
NPSM female Swivel adapters		Hose adapters National pipe straight thread for mechanical joint 30° cone male / NPTF male thread. SAE J516



Systematic fitting selection

Introduction

Product selection

Ultimate target is to find the “best solution”. This optimum solution provides high system reliability, easy assembly characteristics, low maintenance effort and avoids the use of exotic components. This “best solution” is not the ultimately achievable technology, but an adequate solution which fulfils the requirements of the individual application with minimum system cost. The “best solution” looks different depending on the specific criteria of the given application.

Dry Technology

Modern HPCE fittings are designed for high reliability, easy assembly and lowest total cost performance.

These products are marked *Dry Technology* and indicated grey in selection charts.

Parker recommends to select only *Dry Technology* products for all new designs.

Design criteria for fitting selection

Step 1

First clarify all design criteria for the given application or project.

Step 2

Then determine the “best solution” product. Use selection charts on following pages.

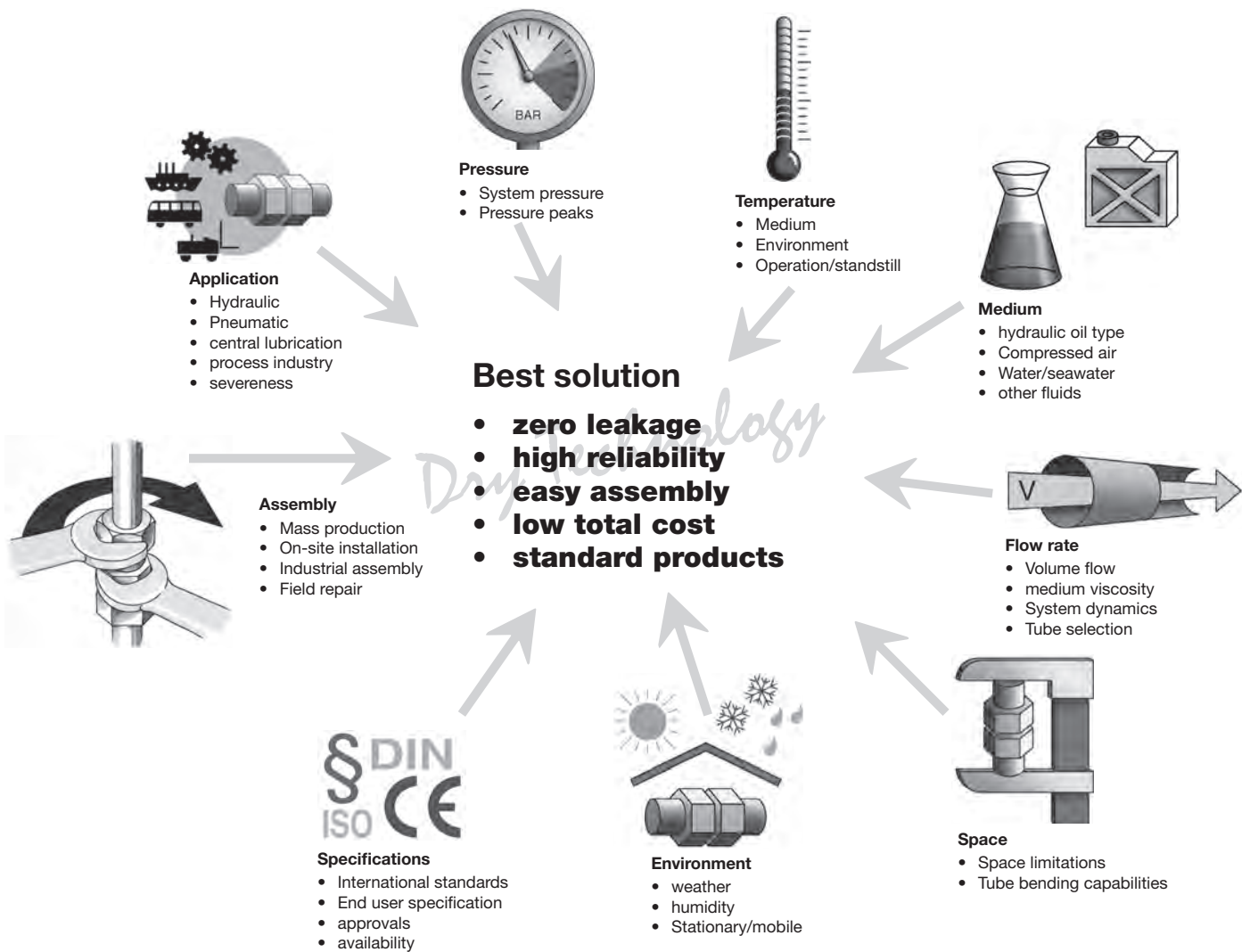

Material selection: Fitting material



Environment

- select fitting material with suitable corrosion resistance



Medium

- select compatible fitting material

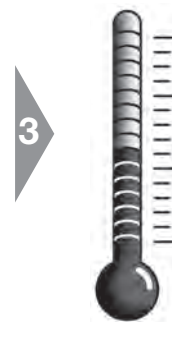

Temperature

- check suitability

Tube Material: Fitting material:	Steel, zinc-plated Steel, zinc-plated	Stainless steel Stainless steel	Copper Brass	Stainless steel Steel	Plastic Steel, Stainless steel, Brass
Performance characteristics:					
Pressure capability	Excellent	Excellent	Good	Excellent	Low
External temperature capability	Very good	Excellent	Very good	Very good	Depending on tube and material
Corrosion resistance	Good	Excellent	Very good	Good	Good
Internal media compatibility	Good	Excellent	Very good	Good	Good
Current use	Standard material combination for general use in hydraulic systems	Standard material combination for use with aggressive media or application in corrosive environments	Low to medium pressure applications in corrosive environment Use with compressed air (condensed water) or slightly corrosive media (water)	Special material combination for mildly corrosive environments	Special material combination for low pressure applications
Typical applications:	Machine tools, Mobile construction equipment	Shipbuilding, Offshore exploration, Process engineering, Paper machines costal installations	Central lubrication systems, Pneumatics, cooling water tubes	Some airbrake systems in railway industry wet machining area on machine tools	Pneumatic systems on machine tools central lubrication and airbrakes in truck industry

Special Materials

"Due to their reliability and corrosion resistance, the austenitic stainless steel that we offer usually meet all the demands in markets, including the oil and gas, marine engineering, power generation, or pulp and paper among others.

However, the unique requirements of some of the projects often demand special approaches. Parker High Pressure Connectors Europe division understand those needs and has the technical knowledge and experience to help our customers to find the better solutions for their applications and meet even the most challenging demands. 1.4547 (6Mo), 1.4539, 2.1972 (CuNiFe), Inconel or other alloys might be offered on request."

Material selection: Sealing material



Medium

- select compatible fitting material

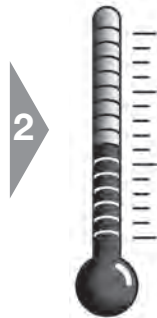

Temperature

- check suitability

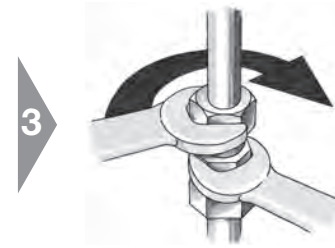

Assembly

- Prefer elastomer sealing for easy assembly and economic service

Sealing technology	metal-to-metal	nitrile rubber (NBR)-Elastomer	Fluorcarbon (FKM)-Elastomer
Performance characteristics:			
High pressure capability	Good	Excellent	Excellent
Low temperature capability	Excellent	Very good	Good
High temperature capability	Excellent	Good	Very Good
Media compability	Excellent	Good	Very Good
Long term reliability	Good	Excellent	Excellent
Assembly characteristics:			
Ease of initial assembly	Good	Excellent	Excellent
Repeated assembly	Good	Excellent	Excellent
Replacement of seal	Not possible	Easy	Easy
Current use	Suitable for aggressive media respectively for very low or very high temperatures	General use in – hydraulic – pneumatic – lubrication – airbrake systems	Hydraulic and pneumatic systems with high operating temperature process engineering: some aggressive media
Typical applications:	Process engineering Agricultural Equipment	Machine tools Hydraulic presses Mobile construction equipment	Steelmill equipment Casting machines

LL/L/S Series selection for EO fittings

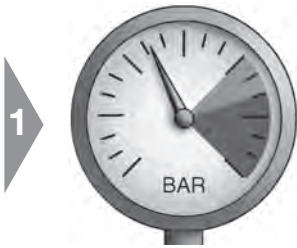

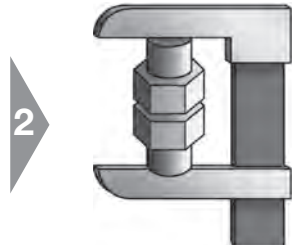

1 Pressure
 • select series with adequate pressure performance



2 Space
 • select series according to available space



3 Specification
 • prefer L or S series for best availability

			
Series	LL	L	S
Example of order code	G06ZLLCF	G06ZLCF	G06ZSCF
Design	Very light	Light	Heavy
Performance PN	100 bar	160–500 bar	315–800 bar
Suitability for heavy duty applications	Good	Good	Excellent
Tube dimension (mm)	4, 6, 8, 10, 12	6, 8, 10, 12, 15, 18, 22, 28, 35, 42	6, 8, 10, 12, 14, 16, 20, 25, 30, 38
Assembly Tightening effort Space requirement	Very low Very low	Normal Low	High High
Current use	Very light design for space-limited assemblies in low to medium pressure applications	medium to high pressure fitting for general use in hydraulic and pneumatic systems	Rigid design for use in heavy-duty applications
Typical applications:	Central lubrication Airbrake systems fuel lines oil/gas stoves micro hydraulics	machine tools agricultural vehicles	hydraulic presses plastic injection molding steel mills shipbuilding Mobile construction equipment

Tube end selection

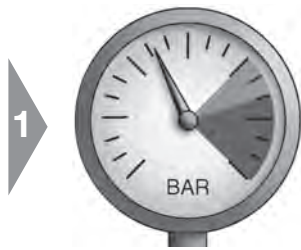

- Pressure**
- select connection type with adequate pressure performance
 - prefer elastomeric seal for most reliable sealing performance

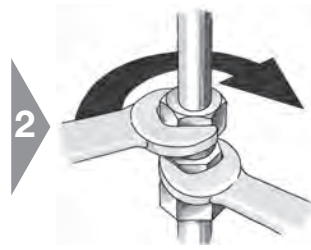

- Assembly**
- select product with adequate assembly process

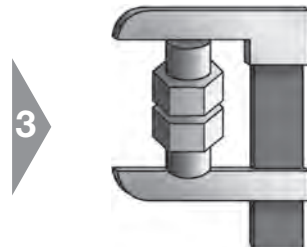

- Space**
- select most suitable product



- Specification**
- fitting type according to project specification

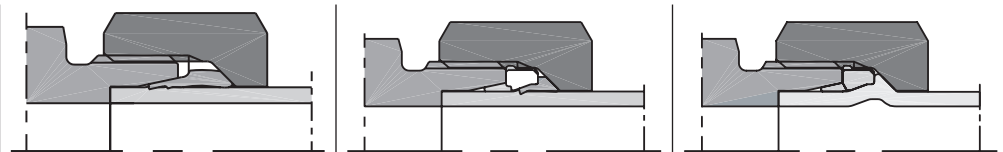

Type	EO PSR/DPR Metal seal bite type	EO-2 Soft seal bite type	EO2-Form Tube forming
Sealing method	Metal seal	Elastomeric seal	Elastomeric seal
International Standard	ISO 8434-1	ISO 8434-1	ISO 8434-1/4
National Standards	DIN EN ISO 8434-1 (old: DIN 2353/DIN 3861)	DIN EN ISO 8434-1 (old: DIN 2353/DIN 3861)	DIN EN ISO 8434-1 (old: DIN 3861)
Tube compatibility	Metal and plastic tube (steel, stainless steel, copper, aluminium, polyamide ...)		Steel, stainless steel, copper alloy
Available sizes (Tube O.D.)	4LL-12LL 6L-42L 6S-38S	4LL-6LL 6L-42L 6S-38S	Tube O.D. 6 to 42 mm 6L-42L 6S-38S
Performance seal reliability	Very good	Excellent	Excellent
Assembly Tube preparation Installation Field repair	Excellent Good Very good	Excellent Very good Excellent	Good Excellent Use EO2
Space requirements	Excellent	Excellent	Good
Current use	Most popular fitting for metric tube		Heavy duty alternative to EO/EO2 and EO weld nipple
	Traditional bite type fitting new designs	Global popularity for all	
Typical applications	General use in hydraulic, pneumatic, lubrication and coupling systems		General use in high pressure applications
	Agricultural equipment Process engineering	Hydraulic presses Injection Molding Mobile equipment Heavy machinery Ship building	Hydraulic presses Injection Molding Mobile equipment Heavy machinery Ship building

Tube end selection

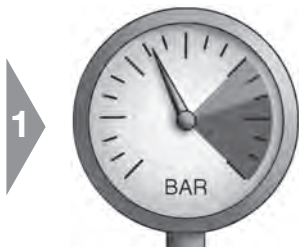

- Pressure**
- select connection type with adequate pressure
 - prefer elastomeric seal for most reliable sealing performance

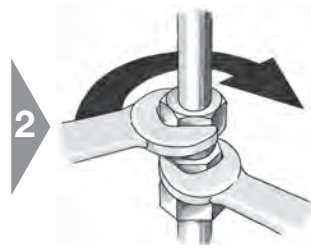

- Assembly**
- select product with adequate assembly process

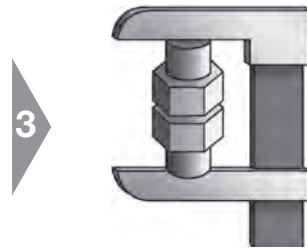

- Space**
- select most suitable product



- Specification**
- fitting type according to project specification

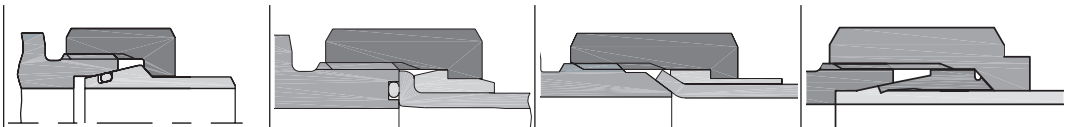

Type	EO SKA Weld nipple	O-Lok® O-Ring Face Seal (ORFS)	Triple-Lok® 37° Flare	Ferulok® Flareless Tube Fitting
Sealing method	Elastomeric seal	Elastomeric seal	Metal seal	Metal seal
International Standard	ISO 8434-1/4	ISO 8434-3	ISO 8434-2	
National Standards	DIN EN ISO 8434-1/-4 (old: DIN 3865)	SAE J1453/J516	SAE J514/J516	SAE J514 / MIL-F-18866H
Tube compatibility	Weldable steel and stainless steel	Metal tube (steel, stainless steel, copper, aluminium)		Metal and plastic tube (steel, stainless steel, copper, aluminium, nylon, polyethylene)
Available sizes (Tube O.D.)	6L-42L 6S-38S	Tube O.D. 6 to 50 mm Tube O.D. 1/4" to 2"	Tube O.D. 6 to 42 mm Tube O.D. 1/8" to 2"	Tube O.D. 1/8" -2"
Performance seal reliability	Excellent	Excellent	Very good	Very good
Assembly Tube preparation Installation Field repair	Difficult Excellent Difficult	Good Excellent Use braze adapter	Good Excellent Hand flaring	Excellent Good Very good
Space requirements	Very good	Good	Very good	Excellent
Current use	Limited use in Northern Europe and Asia	Heavy duty <i>Dry Technology</i> alternative to Triple-Lok® Most popular fitting for inch tube (metric tube on request) USA, Europe, gaining acceptance in Asia.	Worldwide	North America, limited use in Asia and Europe
Typical applications	Limited use for special applications Heavy machinery Ship building power plants	General use in high pressure-hydraulic Mobile equipment Injection Molding Hydraulic presses Heavy machinery Ship building	General use in hydraulic, pneumatic, lubrication and coupling systems Agricultural equipment* Process engineering	General use in hydraulic, pneumatic and lubrication systems Process engineering, railways, mobile equipment

Flange type selection

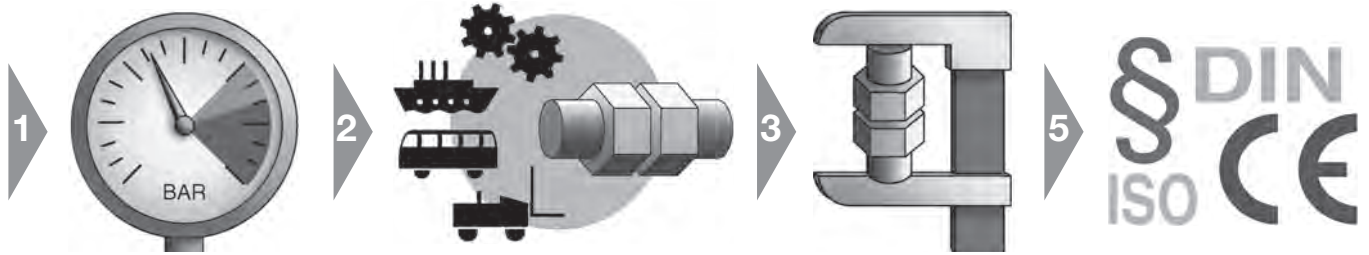

Pressure

- select flange type connection with adequate pressure performance

Application

- select suitable flange type for specific application

Space

- select flange type according to available space

Specification

- select flange type according to project specification

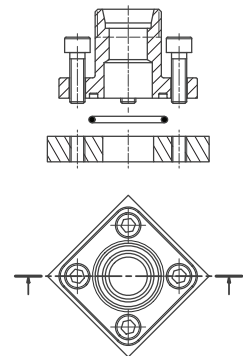
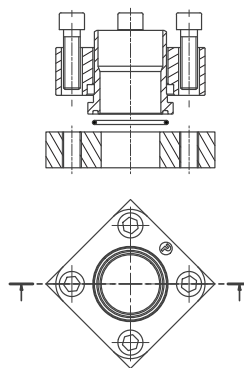
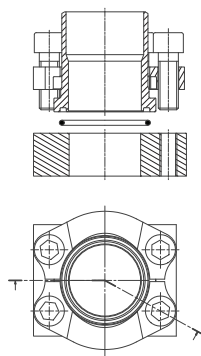

Flange type	Four screw split flange	Four screw one piece square flange	Gear pump flanges
Sealing method	Elastomeric seal	Elastomeric seal	Elastomeric seal
International standard	ISO 6162-1/-2	ISO 6164 (1994)	
National standard	DIN ISO 6162-1/-2/SAE J518	–	–
Tube compatibility	Combines weld and thread connections	Combines weld and thread connections	thread connection
Available sizes (Tube O.D.)	1/2" up to 5"	3/8" up to 4"	10L-42L 16S-30S
Performance seal reliability	Excellent	Excellent	Excellent
Assembly Tube preparation Installation Field repair	Good Excellent Good	Good Excellent Good	Good Excellent Good
Space requirements	Low	Low	Low
Used screws	metric screws according to: ISO 4762-10.9 (DIN 912-10.9) or higher quality UNC bolts according to ANSI/ASME B 18.3*	metric screws according to: ISO 4762-8.8 (DIN 912-8.8) or ISO 4762-10.9 (DIN 912-10.9)	metric screws according to: ISO 4762-8.8 (DIN 912-8.8)
Current use	Widely used throughout the world	Mainly used in Germany	Mainly used in Europe
Typical applications	Agriculture Hydraulic Offshore Ship building Cranes	Agriculture Hydraulic Offshore Ship building Cranes	Agriculture Hydraulic Offshore Ship building Cranes

*UNC bolts acc. to ISO 6162-1 and -2 should not be used for new designs.

Port/Stud selection

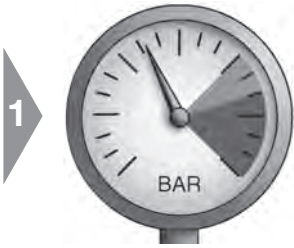

Pressure
 • select connection with adequate pressure performance

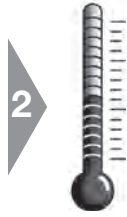

Temperature
 • Use elastomeric seal when suitable

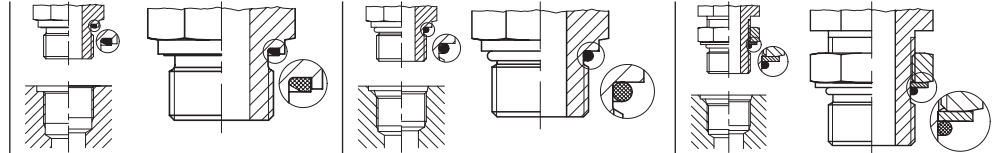

Port end selection:	Male stud with EOLASTIC-seal	Male stud with O-Ring seal	Male stud adjustable with O-Ring seal
Port description metric	Male stud with EOLASTIC-sealing	Male stud with O-ring sealing	Male stud adjustable with O-ring sealing
Thread	Metric	Metric	Metric
Example of order code EO =	GE12ZLMEDCF	GE012ZLMCF	VEE12ZSMORCF
Example of order code Triple-Lok® =	8M16F82EDMXS	8M16F87OMXS;	8M18V87OMXS
Example of order code O-Lok® =	8M16F82EDMLOS	8M16F87OMLOS	8M18V87OMLOS
Thread standard (Example)	M 16×1.5 ISO 261; ISO 724; DIN 13-T5-T7	M 16×1.5 ISO 261; ISO 724; DIN 13-T5-T7	M 18×1.5 ISO 261; ISO 724; DIN 13-T5-T7
Male stud standard	DIN EN ISO 9974-2 (old: DIN 3852 T11, type E)	DIN ISO 6149-2/3 (old: DIN 3852 T3, type F)	DIN ISO 6149-2/3
Port tapping standard	DIN EN ISO 9974-1 (old: DIN 3852 T1, type X, Y)	DIN ISO 6149-1 (old: DIN 3852 T3, type W)	DIN ISO 6149-1 (old: DIN 3852 T3, type W)
Performance characteristics – pressure capacity – sealing characteristics – additional sealant required	Very high Excellent No	Very high Excellent No	High Very good No
Current use	Solid, soft sealing male studs. Known worldwide. Well suitable for using with gas and high pressure hydraulics.	New safe sealing system for all areas of application, especially suitable for high pressure hydraulics. Standard sealing for the future. Identifying marking for metric version is a groove at the collar.	New safe adjustable sealing system for all areas of application, especially suitable for high pressure hydraulics. Standard sealing for the future.
	Well suitable for soften for counter material (e.g. housing of Al-alloy).		
Port description inch	Male stud with EOLASTIC-sealing	Male stud with O-ring sealing	Male stud adjustable with O-ring sealing
Thread	BSP	UN/UNF threads	UN/UNF threads
Example of order code EO =	GE12ZLR1/4EDCF	GE12ZL3/4UNFCF	VEE12ZL3/4UNFCF
Example of order code Triple-Lok® =	8-4F42EDMXS	8F50XS	8V50MXS
Example of order code O-Lok® =	8-4F42EDMLOS	8F50MLOS	8V50MLOS
Thread standard (Example)	G 1/4 A DIN/ISO 228-T1 BS 2779	GB: 1/4 BSPP Japan: 1/4 PF	3/4-16 UNF ISO 725/ANSI B1.1-1974
Male stud standard	DIN 3852 T11, type E ISO 1179-2	ISO 11926-2/3	ISO 11926-2/3
Port tapping standard	DIN 3852 T2, type X, Y ISO 1179-1	ISO 11926-1	ISO 11926-1
Performance characteristics – pressure capacity – sealing characteristics – additional sealant required	Very high Excellent No	Very high Excellent No	High Very good No
Current use	Solid, soft sealing male studs. Known worldwide. Well suitable for soften counter material (e.g. housing of Al-alloy). Well suitable for using with gas and high pressure hydraulics.	Predecessor of metric sealing system. Often used in USA. Well suitable for soften counter material (e.g. housing of Al-alloy). Well suitable for using with gas.	Predecessor of metric adjustable sealingsystem. Often used in USA. Well suitable for soften counter material (e.g. housing of Al-alloy).

Port/Stud selection

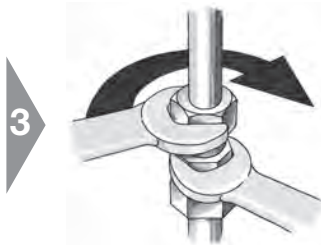

Assembly

- prefer O-Ring/ ED-seal for easy assembly and economic service
- avoid tapered threads



Application

- select standard connection for specific application

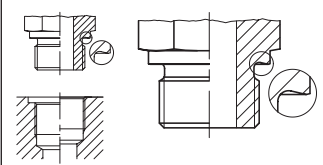
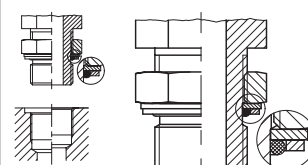
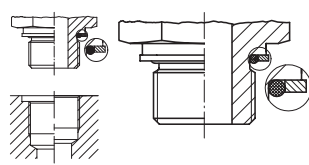

Port end selection:	Male stud O-ring retainer ring	Male stud adjustable with O-ring seal and Backup washer	Male stud with sealing by cutting face
Port description metric	Male stud adjustable with O-ring sealing	Male stud adjustable with O-ring sealing	Male stud with sealing by cutting face
Thread	Metric	Metric	Metric
Example of order code EO =	–	VEE12ZSMCF	GE12LMCF
Example of order code Triple-Lok® =	8M16F80MXS	8M18V80MXS	–
Example of order code O-Lok® =	–	8M18V80MLOS	–
Thread standard (Example)	M 18×1.5 ISO 261; ISO 724; DIN 13-T5-T7	M 18×1.5 ISO 261; ISO 724; DIN 13-T5-T7	M 16×1.5 ISO 261; ISO 724; DIN 13-T5-T7
Male stud standard	–	–	DIN EN ISO 9974-3 (old: DIN 3852 T3, type B)
Port tapping standard	DIN EN ISO 9974-1 (old: DIN 3852 T1, type X, Y)	DIN EN ISO 9974-1 (old: DIN 3852 T1, type X, Y)	DIN EN ISO 9974-1 (old: DIN 3852 T1, type X, Y)
Performance characteristics – pressure capacity – sealing characteristics – additional sealant required	Medium Good No	Medium to high Good No	High Medium to good No
Current use		New adjustable sealing system for all areas of application.	Suitable for aggressive media respectively for very low or high temperatures, where elastic sealing cannot be used.
	Used in Europe and Asia-Pacific areas.		
	Well suitable for soften counter material/e. g. housing of Al-alloy.		
Port description inch	Male stud adjustable with O-ring sealing	Male stud adjustable with O-ring sealing and Backup washer	Male stud with sealing by cutting face
Thread	BSP	BSP	BSP
Example of order code EO =	–	VEE12ZLRCF	GE12LR1/4CF
Example of order code Triple-Lok® =	8-F40MXS	8V40MXS	–
Example of order code O-Lok® =	–	8V40MLOS	–
Thread standard (Example)	G 3/8 A DIN/ISO 228-T1	G 3/8 A DIN/ISO 228-T1	G 1/4 A DIN/ISO 228-T1, BS 2779
Further standards	GB: 1/4 BSPP, Japan: 1/4 PF	GB: 1/4 BSPP, Japan: 1/4 PF	GB: 1/4 BSPP, Japan: 1/4 PF
Male stud standard	ISO 1179-3	ISO 1179-3	DIN 3852 T2, type B, ISO 1179-4
Port tapping standard	ISO 1179-1; DIN 3852 T2, type X, Y	ISO 1179-1; DIN 3852 T2, type X, Y	DIN 3852 T2, type X, Y, ISO 1179-1
Performance characteristics – pressure capacity – sealing characteristics – additional sealant required	High Very good No	Medium to high Good No	High Medium to good No
Current use	Used in Europe and Asia-pacific areas.	Solid, soft sealing male studs. Known worldwide.	Suitable for aggressive media respectively for very low or high temperatures, where elastic sealing cannot be used.
	Well suitable for soften counter material (e.g. housing of Al-alloy).		

Port/Stud selection



Specification

- select connection type according to project specification
- prefer international standards
- select ISO 6149 for new designs

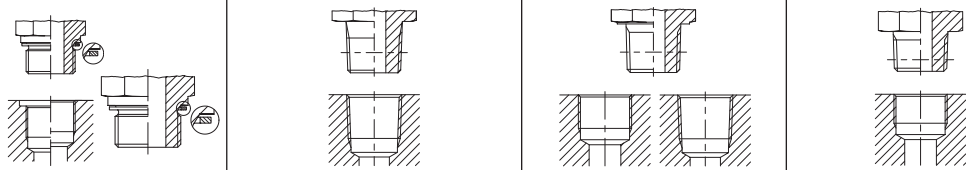

Port end selection:	Male stud with sealing by metal sealing ring	Male stud with sealing by taper thread	Male stud with sealing by taper thread	Male stud with sealing by taper thread
Port description metric	Male stud with sealing by metal sealing ring	Male stud with sealing by taper thread	–	Male stud with sealing by taper thread
Thread	Metric	NPT	–	Metric
Example of order code EO =	GE12LMACF	GE12L1/2NPTCF	–	GE08LLMCF
Example of order code Triple-Lok® =	–	8-8FMTXSS	–	–
Example of order code O-Lok® =	–	8-8FLOSS	–	–
Thread standard (Example)	M 16×1.5; ISO 261; ISO 724; DIN 13-T5-T7	1/2-14 NPT ANSI B1.20.1-1983	–	M 10×1.0 tap. DIN 158
Male stud standard	DIN 3852 T1, type A DIN 7603 (Sealing washer)	ANSI B1.20.1-1983	–	DIN 3852 T1, type C
Port tapping standard	DIN EN ISO 9974-1 (old: DIN 3852 T1, type X, Y)	ANSI B1.20.1-1983	–	DIN 3859 T1, type Z (parallel)
Performance characteristics – pressure capacity – sealing characteristics – additional sealant required	Low Medium No	Very high Medium Yes	–	Low Medium Yes
Current use	Partly used for pneumatics and gas applications.	Mainly used in North America. Some used in rest of the world. Male studs and port tapping are tapered. Sealing only achieved with fluid or plastic sealing material.	–	Only for low requirements due to parallel port. Leakfree performance is only achieved with fluid or plastic thread sealing material. Mainly used in Germany.
Port description inch	Male stud with sealing by metal sealing ring	Male stud with sealing by taper thread	Male stud with sealing by taper thread	Male stud with sealing by taper thread
Thread	BSPP	NPTF	BSPT	Shorter BSPT
Example of order code EO =	GE12LR1/4ACF	–	GE12LR1/2KLCF**)	GE12LR1/4KEGCF
Example of order code Triple-Lok® =	–	12FMTXS	8-8F3MXS	–
Example of order code O-Lok® =	–	12FLOS	–	–
Thread standard (Example)	G 1/4 A DIN/ISO 228-T1 BS 2779	3/4-14 NPTF ANSI B1.20.3-1983	R 1/2 ISO 7; DIN 2999-1 BS 21	R 1/4 (short) DIN 3858
Further standards	GB: 1/4 BSPP, Japan: 1/4 PF	–	GB: 1/4 BSPT; Japan: 1/4 PT	–
Male stud standard	DIN 3852 T2, type A DIN 7603 (Sealing washer)	SAEJ 476a	ISO 7; DIN 2999-1	DIN 3852 T2, type C
Port tapping standard	DIN 3852 T2, type X, Y ISO 1179-1	SAEJ 476a ANSI B1.20.3	ISO 7/1-Rp/Rc; DIN 2999-Rc BS 21-Rp/Rc; Japan PT-Port	DIN 3852 T2, type Z (parallel)
Performance characteristics – pressure capacity – sealing characteristics – additional sealant required	Low Medium No	Very high Medium Recommended	Medium Medium Yes	Low Medium Yes
Current use	More and more unimportant. Partly used for pneumatics.	Mainly used in North America. Male studs and port tapping are tapered. The same as NPT except that closer tolerances are held to assure metal to metal contact (dryseal thread).	Mainly used in GB and Asia-Pacific areas. Male studs are tapered. Ports are mainly tapered, but can be parallel also. Leakfree performance is only achieved with fluid or plastic thread sealing material. **)/Male stud end not included in the catalogue!	Only for low requirements due to parallel port. Leakfree performance is only achieved with fluid or plastic thread sealing material. Mainly used in Germany. Not to be used for BSPT ports and PT ports (Japanese Standard) due to poor thread engagement!

Orientable Fitting Selection

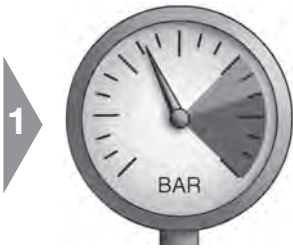

1

Pressure

- pre-select orientable fitting with sufficient pressure performance
- prefer elastomeric seal for most reliable sealing performance

2



Flow Rate

- select optimum solution for best flow rate and available space

Type	90° tube bend and male stud		Swivel Elbow		Adjustable Elbow
EO:	GE12LMCF	GE12ZLMEDCF	EWV	EW	WEE
Triple-Lok®:	FMTX, F3MX	F82EDMX	–	F82EDMX+C6MX	C8OMX
O-Lok®:	–	F82EDMLO	–	F82EDMLO+C6MLO	C8OMLO
Design	DPR/PSR Triple-Lok® Metal sealed port	EO-2 O-Lok® Elastomeric sealed port	Adjustable elbow with preassembled EO-DPR/PSR	Adjustable elbow with swivel nut connection	Adjustable Elbow with adjustable male stud
Sealing method	Metal	Elastomeric	Metal	Elastomeric	Elastomeric
Performance pressure Seal reliability Flow characteristics Compactness	Good Good Excellent Bulky	Excellent Excellent Excellent Bulky	Good Good Very good Good	Excellent Excellent Very good Good	Very good Good Very good Very good
Assembly/Installation Field repair	Very good Good	Excellent Excellent	Good Good	Excellent Excellent	Very good Difficult
Available sizes	Tube Outside Diameter 4 mm to 42 mm for DPR/PSR Triple-Lok® 6 mm to 50 mm and 1/4 in to 2 in	Tube Outside Diameter 4 mm to 42 mm for DPR/PSR/EO-2 Triple-Lok® and O-Lok® 6 mm to 50 mm and 1/4 in to 2 in	Tube Outside Diameter 6 mm to 42 mm for DPR/PSR	Tube Outside Diameter 6 mm to 42 mm for for DPR/PSR/EO-2 Triple-Lok® and O-Lok® 6 mm to 50 mm and 1/4 in to 2 in	Tube Outside Diameter 4 mm to 42 mm for DPR/PSR/EO-2 Triple-Lok® and O-Lok® 6 mm to 50 mm and 1/4 in to 2 in
Available threads	Metric ISO 9974-3 BSPP ISO 1179-4 DIN 3852 Form B NPT/NPFT	Metric ISO 6149 Metric ISO 9974-2 BSPP ISO 1179-2 UN/UNF	Metric ISO 9974-3 BSPP ISO 1179-4 DIN 3852 Form B NPT/NPFT	Metric ISO 6149 Metric ISO 9974-2 BSPP UN/UNF	Metric ISO ISO 6149 Metric ISO 9974-2 BSPP ISO 1179-2 UN/UNF
Current use	preferred use is not critical when space		not for new design	general use	general use
Typical Applications	Agricultural Equipment process engineering	All hydraulic + pneumatic systems	Agricultural Equipment process engineering	All hydraulic + pneumatic systems	All hydraulic + pneumatic systems

Orientable Fitting Selection

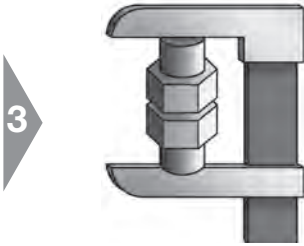

Space
 • select optimum solution for available space and best flow

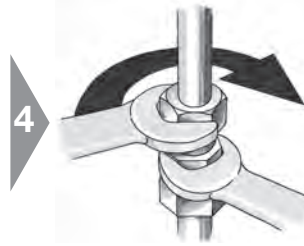

Assembly
 • check, if assembly process is suitable

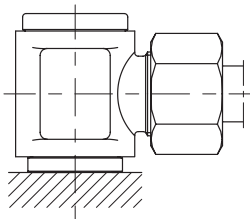
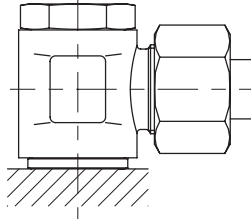
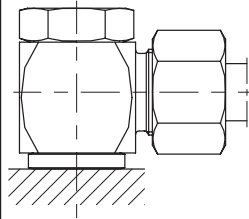
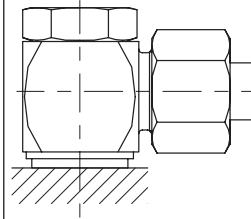
Type	Banjo		High pressure banjo	
				
EO:	DSVW	SWVE	WH DKA	WH KDS
Triple-Lok®:	–	–	–	–
O-Lok®:	–	–	–	–
Design	Fitting body with hollow bolt and cap	Fitting body with hollow bolt	Fitting body with hollow bolt	Fitting body with hollow bolt
Sealing method	Metal	Metal	Metal	Elastomeric
Performance pressure Seal reliability Flow characteristics Compactness	Low pressure Good Good Excellent	Good Good Good Excellent	Very good Good Good Excellent	Very good Excellent Good Excellent
Assembly/Installation Field repair	Good Good	Very good Good	Very good Good	Excellent Excellent
Available sizes	Tube Outside Diameter 4 mm to 42 mm for DPR/PSR	Tube Outside Diameter 4 mm to 42 mm for DPR/PSR	Tube Outside Diameter 6 mm to 42 mm for DPR/PSR	Tube Outside Diameter 6 mm to 42 mm for DPR/PSR/EO-2
Available threads	– Metric DIN 3852 BSPP –	– Metric BSPP –	– Metric BSPP –	– Metric BSPP –
Current use	Low pressure systems only, not for new designs	Low pressure systems only	Best solution for limited application space	
Typical Applications	Airbrake systems Return lines	Low to medium pressure systems	Space critical applications such as: forklift trucks Mobile hydraulics	

Standardization



- Specification**
- select fittings according to international standardisation
 - check specification of end-customer/end user
 - consider project-specific guidelines
 - avoid non-standard items

ISO-fitting standards				National Standards	
EO 24° fittings DIN EN ISO 8434-1/-4 (former: DIN 2353)	Triple-Lok® ISO 8434-2 • 37° flared fittings	O-Lok® ISO 8434-3 • O-ring face seal fittings	K4 Adapter ISO 8434-6 • BSPP 60° cone adapter	P4 Adapter JIS B 8363 JIS BSPP 60° cone dapter	NPSM-Adapter SAE J 516 NPTF 30° cone

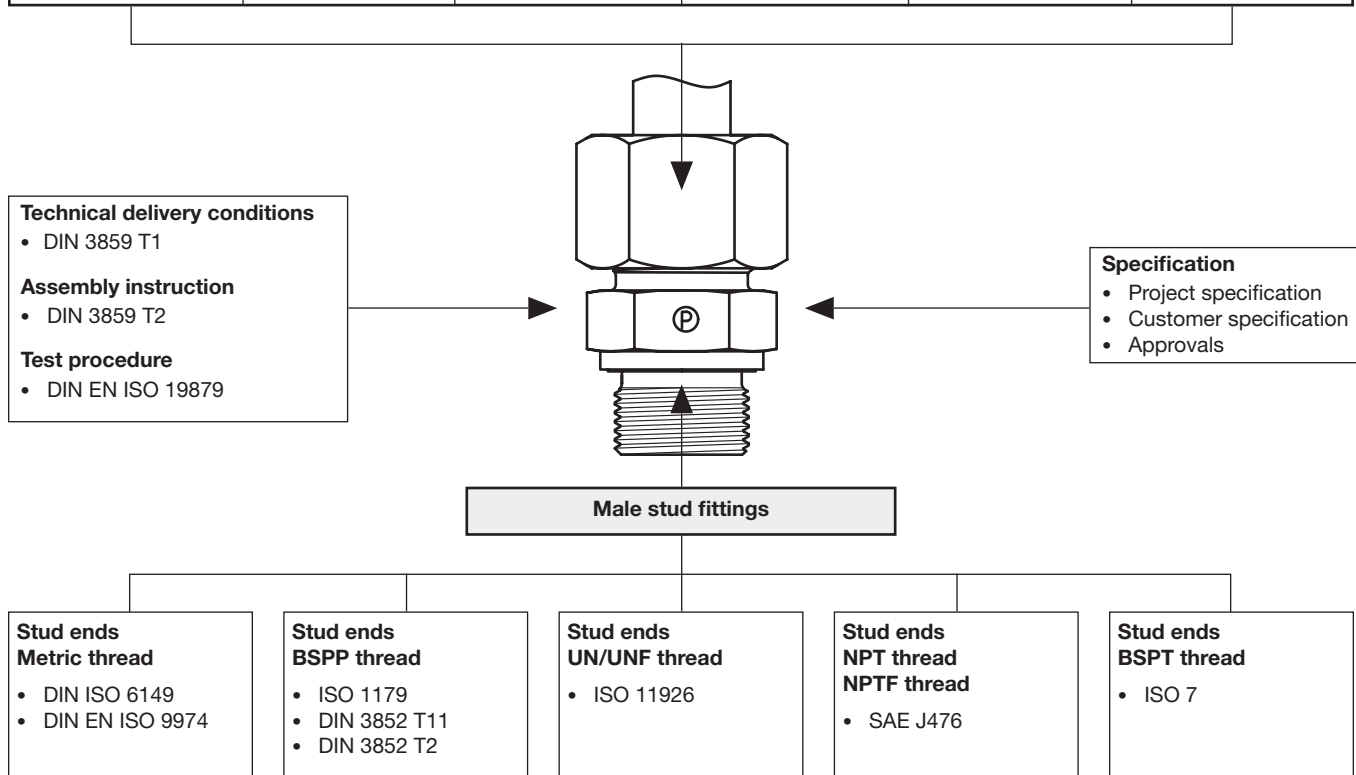

Approvals

Parker tube fittings are recognized by various acceptance organizations, among which are:

- Germanischer Lloyd (GL)
- Lloyds Register of Shipping (LR)
- Det Norske Veritas (DNV)
- American Bureau of Shipping (ABS)
- Russian Maritime Register of Shipping (RMS)
- China Classification Society (CCS)
- Deutscher Verein des Gas- und Wasserfaches (DVGW)

For other applications, Parker tube fittings also approved by diverse national authorities.

Numerous original equipment manufacturers and end-users of various industries have approved Parker tube fittings.

Attention:

Type Approvals usually are limited to certain products, applications, working conditions, validity time or other restrictions. We gladly inform you on your individual application and send out the required documentation.

Tube Specifications

Tubes with metric outside diameters

Tube material Steel	Speci- fication	Construction	Condition	Tolerances OD/ wallthickness	Surface	Suitable fitting systems				Note
						DPR/PSR/ EO-2	EO-2 Form	T- Lok®	O-Lok®	
E235 (= 1.0308)	DIN EN 10305-4	Seamless cold drawn	+N (= normal annealed)	EN 10305-4	phosphated, oiled or A3C or CF	X	X	X	X	1)
R37	ISO 3304		NBK (= normal annealed)	ISO 3304		X	X	X	X	2)
E355 (= 1.0580)	DIN EN 10305-4		+N (= normal annealed)	EN 10305-4		X	X	X	X	3)
R50	ISO 3304		NBK (= normal annealed)	ISO 3304		X	X	X	X	4)

Tube material Stainless steel	Speci- fication	Construction	Condition	Tolerances OD/ wallthickness	Surface	Suitable fitting systems				Note
						DPR/PSR/ EO-2	EO-2 Form	T- Lok®	O-Lok®	
1.4571 (= TP 316 Ti)	DIN EN 10216-5	Seamless cold drawn	CFA	DIN EN 10305-1	plain	X	X	X	(X)	5)
1.4541 (= TP 321)						X	(X)	X	(X)	6)
1.4404 (= TP 316L)	EN ISO 1127 or ASTM A269/A213		Solution heat treated (bright annealed)	D4/T3* (EN ISO 1127) or ASTM A269/A213		X	(X)	X	X	7)
1.4301 (= TP 304)						X	(X)	X	X	8)
1.4306 (= TP 304L)	EN ISO 1127	Welded tube	DIN 17457-K2 for OD 6–12 mm, cold drawn welded (CDW) with smooth outer surface for OD 14–42 mm	D4/T3* (EN ISO 1127) or ASTM A269/A213	plain, weld seam approx. invisible	X	(X)	X	X	9)
1.4301 (= TP 304)						X	(X)	(X)	(X)	10)
1.4541 (= TP 321)						X	(X)	(X)	(X)	

Tube material Copper	Speci- fication	Construction	Condition	Tolerances OD/ wallthickness	Surface	Suitable fitting systems				Note
						DPR/PSR/ EO-2	EO-2 Form	T- Lok®	O-Lok®	
Cu DHP R290/250/200	EN 1057 EN 12449	Seamless tube	EN 1057 EN 12449	EN 1057 EN 12449	clean, smooth plain	X	X	X	X	11)

- 1) Recommended EO standard precision tubes for high pressure hydraulic applications. Tight tolerances for easy handling. Good bendability and weldability.
- 2) Tolerance on large tube OD's not as tight as EO tube.
- 3) Precision tubes for very high pressure hydraulic applications. Tight tolerances for easy handling. Good bendability and weldability.
- 4) Tolerance on large tube OD's not as tight as EO tube.
- 5) Recommended EO standard precision tubes for high pressure hydraulic applications. Tight tolerances (same as steel tubes) for easy handling. Good weldability and corrosion resistance. () = on request
- 6) Recommended EO standard precision tubes for high pressure hydraulic applications. Tight tolerances (same as steel tubes) for easy handling. Good weldability. () = on request
- 7) Common tube, OD. tolerance not as tight as EO tube. Good weldability and corrosion resistance. () = on request
- 8) Common tube, OD. tolerance not as tight as EO tube. () = on request
- 9) Common tube, OD. tolerance not as tight as EO tube. () = on request
- 10) Used in Pneumatic (low pressure) applications. () = Only for tube with smooth outer and inner surface.
- 11) Support sleeve "VH" may be required, e.g. for R250-28x1.5.

* = For DPR/PSR/EO-2 systems: thin walled tubes which need a support sleeve require tighter tolerance class T4. Tube O.D. tolerance class D3 is not recommended. D3 may reduce function and capability of the tube connection systems. The outside diameter tolerance is theoretically too large for EO2-FORM and an outer tube diameter of 25-42 mm.

Systematic fitting selection

Tube Specifications

Tubes with imperial (inch) outside diameters

Tube material Steel	Specification	Construction	Condition	Tolerance OD/ wallthickness	Surface	Suitable		Note
						T- Lok®	O-Lok®	
Carbon steel C-1010	SAE J524 (AMS 5050 J, ASTM A179)	Seamless	Fully annealed	SAE J524 (AMS 5050 J, ASTM A179)	plain, oiled	X	X	1)
	SAE J525	Welded and drawn		SAE J525		X	X	2)

Tube material Stainless steel	Specification	Construction	Condition	Tolerance OD/ wallthickness	Surface	Suitable		Note
						T- Lok®	O-Lok®	
1.4404 (= TP 316L)	ASTM A269, ASTM A213	Seamless	Fully annealed	ASTM A269, ASTM A213	plain	X	X	3)
1.4301 (= TP 304)						X	X	4)
1.4401 (= TP 316)						X	X	
1.4404 (= TP 316L)	ASTM A249, ASTM A269	Welded and drawn		ASTM A249, ASTM A269		X	X	
1.4301 (= TP 304)						X	X	
1.4401 (= TP 316)						X	X	

Tube material Copper	Specification	Construction	Condition	Tolerance OD/ wallthickness	Surface	Suitable		Note
						T- Lok®	O-Lok®	
Copper	SAE J528 (ASTM B-75)	Seamless	Soft annealed Temper "O"	SAE J528 (ASTM B-75)	plain	X	X	4)

- 1) Recommended EO tubes for Hydraulic/Pneumatic applications
- 2) Common tubes in North-America
- 3) Recommended tubes for Hydraulic/Pneumatic applications. Good weldability and corrosion resistance
- 4) Tubes in North-America

Fitting selection summary

Traditional bite-type fittings have been originally developed and designed for operating conditions of fluidpower systems completely different from today's and future market requirements.

New products and improved assembly technologies have been developed and introduced by Parker to fulfill today's and future requirements of the operators of fluidpower equipment. This new tube fitting generation and the according assembly methods are classified as *Dry Technology*. All qualifying products are explicitly *Dry Technology*-labelled throughout this catalogue.

For all new designs of

- hydraulic systems
- pneumatic systems,
- coolant systems,
- lubrication systems and
- sprinkler systems

only *Dry Technology*-classified components should be selected.

Dry technology versus traditional technology

EO-2 versus bite type

- + Elastomeric seal
- + Sufficient seal volume to compensate tube tolerance
- + High degree of fine sealing
- + Long-term reliability without retightening
- + No air ingress
- + Clear hit-home-feel at assembly
- + Easy assembly check
- + Integrated preassembly tool
- + No stress of inner cone of fitting body
- + No wear of preassembly tools
- + Direct assembly of stainless steel tubes possible (EO-2)
- + No galling of stainless steel threads
- + Existing tools and EOMAT machines can be used for efficient assembly (EO-2)
- + All parts integrated in Functional Nut (EO-2)
- + No confusion of individual ferrules
- + Less handling effort
- + Unlimited repeated assembly
- + Seal can be individually replaced
- + ISO-standardised (DIN EN ISO 8434-1)
- + Million times proven product since 1993 (EO-2)
- + Interchangeable with EO Progressive Ring (EO-2)
- Higher component cost than traditional bite-type fittings
- + Low total cost
- + Best value for end user
- + Mandatory specified from various industries, such as: automotive production, injection molding, mobile equipment, shipbuilding and offshore exploration
- + Globally gaining popularity

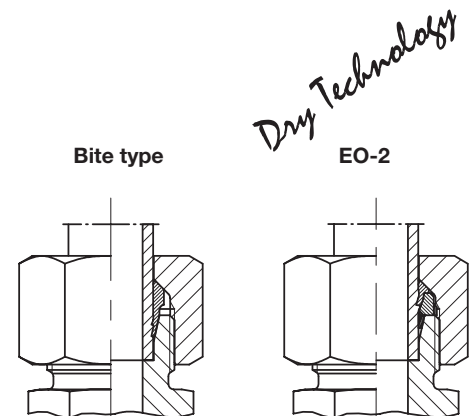

Systematic fitting selection

O-Lok® versus traditional Triple-Lok®

- + Higher pressure resistance than Triple-Lok®
- + Elastomeric seal
- + Sufficient seal volume to compensate tube tolerance
- + High degree of fine sealing
- + Long-term reliability without retightening
- + No air ingress
- + Clear hit-home-feel at assembly
- + Easy assembly check
- + Easy installation of flat-face components
- + Superior vibration resistance
- + Parflange® orbital flanging technology
- + Unlimited repeated assembly
- + Seal can be individually replaced
- + ISO-standardised (DIN EN ISO 8434-2)
- + Million times proven product
- Higher component cost than Triple-Lok®
- Parflange® machine required
- + braze sleeves can be used for field repair
- + Low total cost
- + Best value for end user
- + Mandatory specified from various industries, such as:
agricultural equipment, mobile construction machines, injection molding
- + Globally gaining popularity

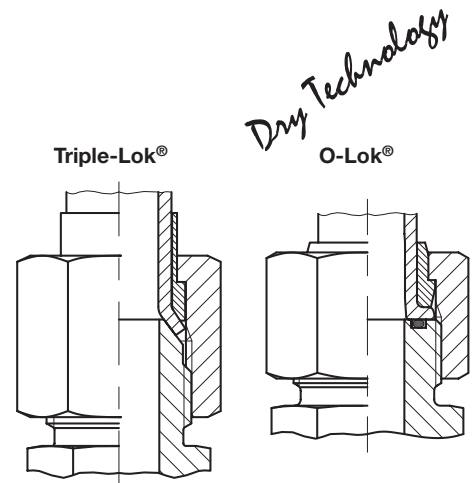

EO2-FORM versus traditional Weld nipple

- + Safe, form-fit connection
- + Easy assembly process
- + trouble-free with zinc-plated tube
- + Elastomeric seal
- + Sufficient seal volume to compensate tube tolerance
- + High degree of fine sealing
- + Long-term reliability without retightening
- + No air ingress
- + Clear hit-home-feel at assembly
- + Easy assembly check
- + Easy tube preparation
- + Easy quality inspection
- + No rework of welding
- + Use of existing EO-2 seals
- + Unlimited repeated assembly
- + Seal can be individually replaced
- + ISO-standardised (DIN EN ISO 8434-1/-4)
- + Basic product EO-2 is million times proven
- + Interchangeable with EO Progressive Ring (EO-2)
- + No new or additional components required
- Higher component cost than traditional bite-type fittings
- EO2-FORM machine required
- + EO-2 can be used for field repair
- + Low total cost
- + Best value for end user
- + Approved for application in hydraulic presses, injection molding, lifts, waterlocks and shipbuilding
- + Globally gaining popularity

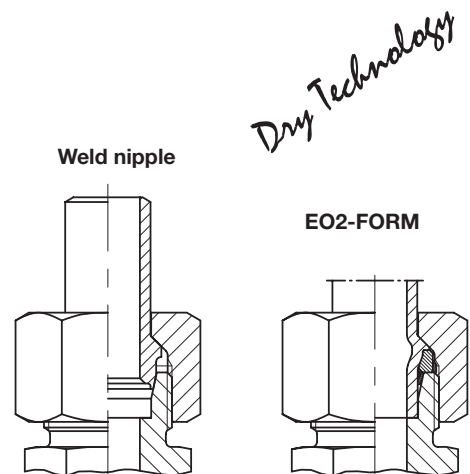

Swivel adjustable versus traditional standpipe

- + Elastomeric seal
- + High degree of fine sealing
- + Long-term reliability without retightening
- + No air ingress
- + Superior pressure rating
- + High mechanical strength
- + No blow-out at incomplete assembly
- + Easy fitting installation
- + No stress of inner cone of fitting body
- + No wear of preassembly tools
- + Unlimited repeated assembly
- + Seal can be individually replaced
- + ISO-standardised (DIN EN ISO 8434-1/-4)
- + Milliontimes proven product since 1970
- + Interchangeable with EO standpipe fittings
- Higher component cost than traditional standpipe fittings
- + Low total cost
- + Best value for end user
- + Mandatory specified from various industries, such as:
automotive production, injection molding, mobile equipment, shipbuilding and offshore exploration
- + Most frequently used and still gaining popularity

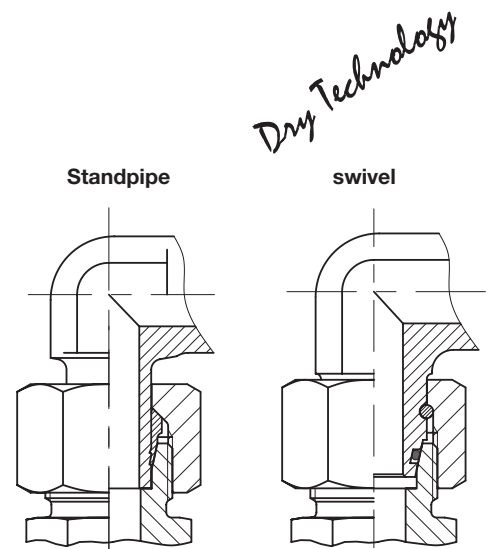

Male stud with Elastomeric or O-ring seal versus traditional Metal seal tapered thread

- + Elastomeric seal
- + High degree of fine sealing
- + Long-term reliability without retightening
- + No air ingress
- + Superior pressure rating
- + Clear hit-home-feel at assembly
- + No damage to port surface
- + Assembly and performance almost independent of port material
- + Low assembly torques
- + No metal sealing edge which may be damaged at transport or handling
- + Unlimited repeated assembly
- + Seal can be individually replaced
- + ISO-standardised (ISO 1179/ISO 6149/DIN ISO 6149)
- + Million times proven product since 1964
- + Interchangeable with traditional fittings
- + Wider product range and better availability
- Higher component cost than traditional bite-type fittings
- + Low total cost
- + Best value for end user
- + Mandatory specified from various industries, such as:
automotive production, injection molding, mobile equipment, shipbuilding and offshore exploration
- + Most frequently used and still gaining popularity

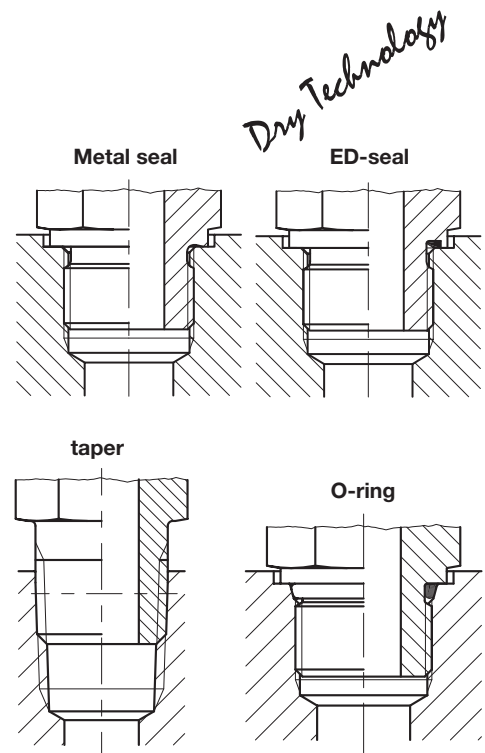

Systematic fitting selection

Locknut Adjustables versus tapered thread

- + Elastomeric seal
- + High degree of fine sealing
- + Long-term reliability without retightening
- + No air ingress
- + Good flow characteristic
- + 360° orientable
- + More compact than swivel orientable combination
- + No additional sealant required
- + Clear hit-home-feel at assembly
- + No damage to port surface
- + Assembly and performance almost independant of port material
- + Low assembly torques
- + Unlimited repeated assembly
- + Seal can be individually replaced
- + Interchangeable with traditional fittings
- + Available in 90°, 45° elbow, T- and Run-T-configuration
- Machined spot surface required
- + Lower price than Banjo fittings
- + Low total cost
- + Best value for end user
- + Globally gaining popularity

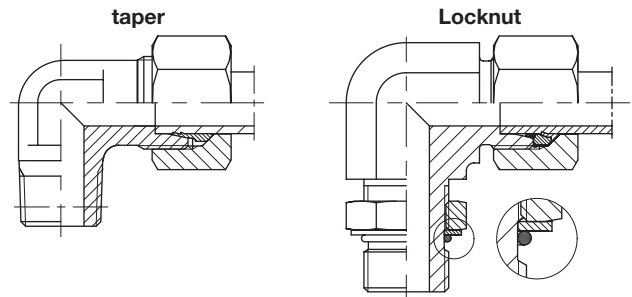

High pressure banjo versus traditional low pressure elbow

- + Elastomeric seal
- + High degree of fine sealing
- + Long-term reliability without retightening
- + No air ingress
- + 360° orientable
- + Compact design
- + Suitable for high pressure applications
- + Matching small spot surface
- + Clear hit-home-feel at assembly
- + No damage to port surface
- + Assembly and performance almost independant of port material
- + Seal does not fall off
- + Only one hollow bolt needs to be tightened
- + No hidden screw
- + Unlimited repeated assembly
- + Seal can be individually replaced
- + Million times proven product since 1980
- + Interchangeable with traditional fittings
- + Available in 90°elbow and T-configuration
- Slight flow restriction
- + Low total cost
- + Best value for end user
- + Globally gaining popularity

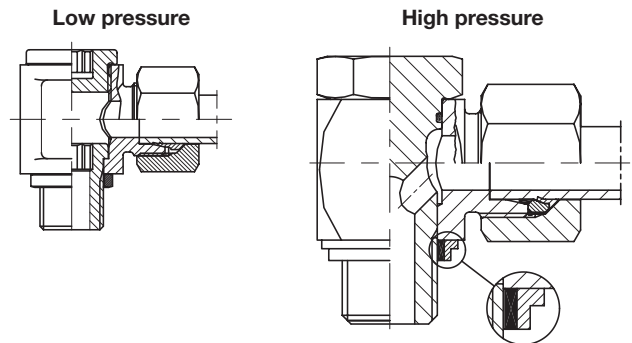



EO[®] Ermeto Original
Performance data



Pressure rating

Nominal pressure PN

The Nominal pressure PN is a figure relating to the pressure rating of a fluid component for continuous dynamic applications. It is rounded to correspond to internationally standardised ratings. Logical series of fittings are grouped together, with the nominal pressure of the group being that of the "lowest common denominator" within the group.

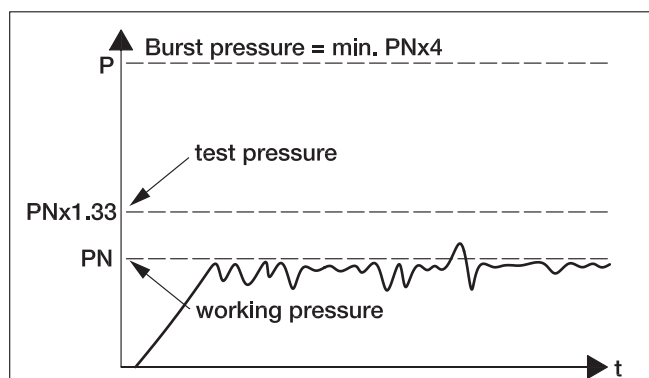

Internationally, these nominal pressures are recognised and serve to match common sizes of components together. Parker tube fittings meet or exceed common standardised pressure ratings.

To prove the long term dynamic load resistance, components are tested under pressure impulse conditions of $PN \times 1.33$, at 1Hz for 1 million cycles. Static test burst pressures are at least 4 times the PN value.

Exception: for ball valves the static test burst pressures are at least 1.5 times the PN value according to DIN 3230 T5 and ISO 5108.

Conversion chart

Bar	Mpa	PSI
100	10.0	1450
160	16.0	2321
210	21.0	3045
315	31.5	4569
350	35.0	5075
400	40.0	5801

Pressure reductions and temperatures

Required pressure reductions (dependant on the material) with reference to the catalogue pressures for higher temperatures. Both metal fitting material and elastomeric sealing compound have to be selected according to the temperature range of the system.

Attention: Fluid Compatibility see page C5.

Fittings material	Pressure reduction of permissible operating temperatures TB in °C														
	-60	-50	-40	-35	-25	+20	+50	+100	+120	+150	+175	+200	+250	+300	+400
Steel, fittings						0%				-11%	-19%	-28%			
Steel, tubes						0%				-19%		-27%			
Stainless steel, fittings						0%				-11%		-20%		-30%	
Stainless steel, tubes						0%		-5.5%	-11.5%	-21.5%			-29%	-34%	
Brass, fittings ¹⁾															
Sealing material NBR (e.g. Perbunan)															
Sealing material FKM															
Sealing material EPDM ²⁾															

- Permissible operating temperature
- Ambient temperature of hydraulic and pneumatic applications
- Temperature not permissible

Perbunan = registered trademark of Bayer
¹⁾ 35 % from material 1.4571 (if not extra shown in PN-Column "MS" for Brass)
²⁾ EPDM is not compatible with oil (not normally held in Stock)

Calculation example:
 PN fitting 16S/71 = 400 bar
 Temperature = 200°C
 Material = Stainless steel
 Pressure reduction fittings = 20 %
 Pressure reduction tubes = 21,5 %
 PN tube 16 x 2.5/71, DIN 2413 III = 362 bar

Formula:

$$PN_{\text{fitting } 200^{\circ}\text{C}} = \frac{400 \text{ bar}}{100\%} \times (100\% - 20\%) = 320 \text{ bar}$$

$$PN_{\text{tube } 200^{\circ}\text{C}} = \frac{362 \text{ bar}}{100\%} \times (100\% - 21,5\%) = 284 \text{ bar}$$

Materials

Fittings	Raw material	Material				Fitting type										
						EO				O-Lok®			Triple-Lok®			
		Designation ²⁾	Material No.	Standard	US Designation ²⁾	Bodies	Nuts	Ferrules	Weld fittings	Bodies	Nuts	Sleeves	Bodies	Nuts	Sleeves	
Steel	Barstock	11SMnPb30	1.0718	DIN EN 10277-3	SAE 12L14	X				X		X	X		X	
	Free cutting steel	11SMn30	1.0715	DIN EN 10277-3	SAE 1213	X										
		46S20	1.0727	DIN EN 10277-3	SAE 1146	X										
	Forgings Free cutting steel	15S10	1.0710	DIN 1651		X										
		11SMn30 modified	1.0715	DIN EN 10087	SAE 1213 modified					X				X		
		36SMn14	1.0764	DIN EN 10087		X										
	Extrusion steel	C45 modified	1.0503	DIN EN 10083	SAE 1045 modified		X					X			X	
		C10C	1.0214	DIN EN	SAE C1010		X					X	X		X	X
	Weldable steel	C15	1.0401	DIN 10277-3					X							
	Other	Steel at the manufacturers discretion special heat treated							X							X
Stainless steel	Barstock	X6CrNiMoTi 17-12-2	1.4571	DIN EN 10088	ANSI 316Ti	X	X		X							
		X2CrNiMo 17-13-2	1.4404	DIN EN 10088	ANSI 316L					X	X	X	X	X	X	
	Forgings	X6CrNiMo Ti17-12-2	1.4571	DIN EN 10088	ANSI 316Ti	X	X		X							
		X5CrNiMo 17-12-2	1.4401	DIN EN 10088	ANSI 316					X	X	X	X	X	X	
	Other	Stainless steel at the manufacturers discretion special heat treated							X							
Brass	Barstock	CuZn35Ni2	2.0540	DIN 17660		X	X	X								
				ASTM B16/B453	CA360/345				X	X	X	X	X	X		
	Forgings	CuZn35Ni2	2.0540	DIN 17660		X										
				ASTM B124	CA377				X			X				

1) Non standard fitting types like e.g. banjo fittings, rotary fittings, adjustable fittings with locknut and flanges might be made from different materials.

2) Equivalent materials may be used

Forging: 11 SMn 30+Bi (similar to 1.0715/DIN EN 10087)

Straight: 11 SMn Pb30 (1.0718/DIN EN 102773)

Special Material

"Due to their reliability and corrosion resistance, the austenitic stainless steels that we offer usually meet all the demands in markets, including the oil and gas, marine engineering, power generation, or pulp and paper among others. However, the unique requirements of some of the projects often demand special approaches. Parker Tube Fitting Division Europe understand those needs and has the technical knowledge and experience to help our customers to find the better solutions for their applications and meet even the most challenging demands. 1.4547 (6Mo), 1.4539, 2.1972 (CuNiFe), Inconel or other alloys might be offered on request."

Sealings	NBR	e.g. N552-90, Perbunan (registered trademark of Bayer)
	FKM	e.g. V894-90
	EPDM	e.g. E540-80
	PTFE	e.g. Teflon® (registered trademark of DuPont)
	POM	e.g. Delrin (registered trademark of DuPont)

Surface treatment

Parker tube fittings from steel are delivered worldwide with a high quality surface protection:

Galvanic zinc plated and bright passivated with special sealer (suffix CF).

Why zinc plated?

The requirements for corrosion resistance of tube fittings have been increasing in the past few years. Increasingly tube systems are not painted. Higher demands are requested also for an aesthetic point of view.

The traditional black-grey surface “phosphated and oiled” (Znphr5f – DIN 50942) used for tube connections in the past does not longer meet these demands. An galvanized deposit zinc layer offers the following advantages: The corrosion resistance increases significantly due to a plating of min. 8 µ and additional sealing by chromating process. In case of scratches or nicks – which are unavoidable during assembly – zinc develops a cathodical protection of the steel fitting body against localised corrosion and abrasion.

The corrosion resistance of the CF surface is 400 % above zinc plated surfaces to meet highest requirements. The CF surface is also Cr(VI)-free to avoid any contamination in

the manufacturing process and meets current regulations e.g. European “End of Life Vehicles“ directive.

The silver bright colour due to the chromating or passivation process offers an attractive appearance.

All major HPCE manufacturing locations are equipped with their own modern galvanic plants. The process control is specially orientated to the tube fitting product.

The users of Parker fittings benefit from:

- homogeneous thickness of plating (average 13 µm), measured on outside contour for good screwable threads
- high quality above-average concerning avoidance of nicks
- very good corrosion resistance

Continuous corrosion tests like salt spray tests according to ISO 9227/5% NaCl show an average resistance of 500 hr in contrast to white rust and 700 hr in contrast to red rust for CF surfaces.

Particular fitting series or fitting components and valves are delivered with other or modified surfaces for functional reasons or for better differentiation.

Material	Fitting system	Fitting type	Surface protection/Surface						
			CF/Cr3* Zinc plated bright passivated	CF + Glide coating	A3K Zinc plated bright passivated	Znphr5f black phosphated	Plain no coating	Plain + Glide coating	Plain + Inside silver
Steel	EO-2	Fitting bodies	X						
		Functional nuts		X					
	EO	Fitting bodies	X						
		Nuts		X					
		Progressive stop rings			X				
		Weld fittings				X			
	EO2-FORM	Bodies and nuts from EO are used							
	O-Lok®	Fitting bodies	X						
		Nuts	X						
		Parflange® sleeves	X						
		Brazing sleeves					X		
	Triple-Lok®	Fitting bodies	X						
		Nuts	X						
Sleeves		X							
Stainless steel	EO-2	Fitting bodies					X		
		Functional nuts up to 12-L/10-S						X	
		Functional nuts from 15-L/12-S							X

Material	Fitting system	Fitting type	Surface protection/Surface						
			CF/Cr3* Zinc plated bright passivated	CF + Glide coating	A3K Zinc plated bright passivated	Znphr5f black phosphated	Plain no coating	Plain + Glide coating	Plain + Inside silver
Stainless steel	EO	Fitting bodies					X		
		Nuts up to 12-L/10-S						X	
		Nuts from 15-L/12-S							X
		Progressive rings				X			
	E02-FORM	Bodies and nuts from EO are used							
	O-Lok®	Fitting bodies					X		
		Nuts					X		
		Sleeves					X		
	Triple-Lok®	Fitting bodies					X		
		Nuts					X		
		Sleeves					X		
	Brass	All systems	Fitting bodies					X	
Nuts							X		
Sleeves & ferrules							X		

A3K according to DIN EN ISO 4042 / Znphr5f according to DIN EN ISO 3892 and DIN 50942

O-Lok and Triple-Lok parts are plated Cr3 and conform to FC-F01 specification, 120 hours to white rust, 240 hours to red rust.

Fluid compatibility

Both metal fitting material and elastomeric seal compound have to be selected according to the fluid used. Standard recommendations for static seals based on experience and sealing compound manufacturers specification. For use of sealing compounds that are used for dynamic seals like rotary fittings or non-return-valves, see note at end of table.

Fluid	Fitting material			Sealing material		
	Steel	Stainless steel	Brass	NBR	FKM	EPDM
Acetone	2	1	1	3	3	1
Acetylene	2	1	3	3	3	2
Air (oil free)	1	1	1	1	1	1
Ammonia liquid	2	1	3	2	3	1
Ammonia gas, cold	1	1	3	1	3	1
Animal oils (Lard oil)	2	2	2	1	1	2
Aral, Vitam BAF	1	1	X	1	1	3
Argon	1	1	1	1	1	1
Asphalt	3	1	3	2	1	3
ASTM-Oil, no. 1	1	1	1	1	1	3
ASTM-Oil, no. 2	1	1	1	1	1	3
ASTM-Oil, no. 3	1	1	1	1	1	3
ASTM-Oil, no. 4	1	1	1	2	1	3
ATF oil	1	1	1	1	1	3
Automotive brake fluid	1	1	1	3	3	1
Benzene	1	1	1	3	1	3
Brine (sodium chloride)	X	2	X	1	1	1
Butane	1	1	3	1	1	3
Carbon bisulphide	1	1	3	3	1	X
Carbon dioxide	1	1	1	1	2	1
Carbon oxide	1	1	1	1	1	1
Castrol, Biotec HVX	1	1	X	1	1	3
Chlorine (dry)	3	1	3	3	1	X
Compressed air	1	1	1	1	1	1
Crude oil	2	1	3	2	1	3

Fluid	Fitting material			Sealing material		
	Steel	Stainless steel	Brass	NBR	FKM	EPDM
Cutting oil	1	1	X	1	3	1
DEA, Econa E22	1	1	X	1	X	3
DEA, Econa E46	1	1	X	1	X	3
Diesel fuel	1	1	1	1	1	3
ECOOL	1	1	X	1	1	X
ESSO, Univis 13	1	1	X	1	1	3
ESSO, Univis 26	1	1	X	1	1	3
ESSO, Univis 32	1	1	X	1	1	3
ESSO, Univis 46	1	1	X	1	1	3
Ethanol (Ethylacohol)	1	1	1	1	3	1
Ether	1	1	1	3	3	2
FINA, Biohydran RS 38	1	1	X	1	1	3
Flue gas	3	1	3	3	2	X
FRAGOL, Hydrolub 125	1	1	X	1	X	3
Freon 11	X	X	1	2	2	3
Freon 12	1	3	1	2	1	3
Freon 22	3	1	1	3	2	3
Gasoline	2	1	1	2	1	3
Gas, liquid propane (LPG)	1	1	1	1	1	3
Glycerine	2	1	2	1	1	1
Glycol (Ethylenglykol)	1	1	2	1	1	1
Heating fuel oil	1	1	1	1	1	3
Helium	1	1	1	1	1	1
Houghton Safe 1120	1	1	X	3	1	1
Houghton Safe 620	1	1	X	1	2	1
Hydrochlorid acid	3	2	3	3	1	2
Hydrogen	3	1	X	3	3	3
Hydrogen peroxide	3	1	3	3	1	2
Hydrolube	1	1	1	1	1	1
Iodine	3	1	3	2	1	2
Kerosene	1	1	1	1	1	3
Lubricating oil SAE 10,20,30,40,50	1	1	1	1	1	3
Methane	1	1	1	1	1	3
Methanol	1	1	1	1	3	1
MIL-F-8192 (JP-9)	1	1	1	3	1	3
MIL-H-5606	1	1	1	1	1	3
MIL-H-6083	1	1	1	1	1	3
MIL-H-7083	1	1	1	1	2	1
MIL-H-8446 (MLO-8515)	1	1	2	2	1	3
MIL-L-2104 & 2104B	1	1	1	1	1	3
MIL-L-7808	2	1	3	2	1	3
Mineral oil	1	1	1	1	1	3
Natural gas	1	1	2	1	1	3
Natural gas, untreated	3	2 ¹⁾	3	3	3	3
Natural mineral oil	1	1	3	2	1	3
Neon	3	1	1	1	1	1
Nitric acid	3	1	3	3	2	3
Nitrogen	1	1	1	1	1	1
Oil	1	1	3	1	1	3
Oxygen (gas, cold)	3	1	2	3	3	3
Ozone	1	1	3	3	1	1
Petrolatum	1	1	1	1	1	3
Petroleum oil	1	1	1	1	1	3
Phosphoric acid	3	3	1	3	1	2
Plantohyd 32 S	1	1	X	1	1	3
Plantohyd 40 N	1	1	X	1	1	3
Propane	1	1	1	1	1	3
R134A	1	1	1	3	3	1

Fluid	Fitting material			Sealing material		
	Steel	Stainless steel	Brass	NBR	FKM	EPDM
Sea Water	3	2	3	1	1	1
SHELL, Naturelle HF-E-46	1	1	X	1	1	3
SHELL, Tellus Oil DO 32	1	1	X	1	1	3
Silicone oil	1	1	X	1	1	1
Skydrol 500	1	1	3	3	3	1
Skydrol 7000	1	1	3	3	2	1
Soap solutions	3	1	3	1	1	1
Steam	2	1	2	3	3	1
Stoddard solvent	1	1	2	1	1	3
Sulphur dioxide	3	1	3	3	3	1
Sulphuric acid	3	2	3	3	1	3
Toluol	1	1	1	3	2	3
Transmission fluid	1	1	1	1	1	3
Trichlorethane	2	1	X	3	1	3
Turpentine	2	1	3	1	1	3
Water	2	1	1 ²⁾	1	2	1
Xylol	1	1	1	3	1	3

Applicability: 1 = satisfactory

2 = fair

3 = not recommended

X = insufficient data

NBR = e.g. Perbunan (registered trademark of Bayer)

FKM

¹⁾ Untreated natural gas requires stainless steel with reduced material hardness.

²⁾ Brass is resistant against crack under normal circumstances. If overloaded (e.g. by overassembly) the resistance especially against ammoniac and nitric derivatives can be negatively influenced. This might cause the defect of the connection.

This fluid compatibility chart is only applicable on so called "static seals", such as O-rings and profile sealing rings (e.g. ED-seal, DOZ-seal) in tube fitting and flange systems.

For fluid compatibility data of valves, rotary fittings or other multi-function components please review the relevant product pages.

Biodegradable oils

Due to environmental concerns and new legislation biodegradable oils are rapidly gaining importance for both mobile and stationary applications. The usage of non-inflammable fluids will remain limited to special applications like mining, steel mills and heavy machines.

Media

Biodegradable oils can be classified into 3 categories:

HEPG (Glycol based fluids)

- + Wide temperature range (-45°C ... 100°C)
- + Very stable against ageing
- + NBR and FKM seals are compatible
- + Moderate viscosity change with temperature
- + Water soluble
- Not mixable with mineral oils or HEES, HETG types
- Careful flushing recommended when changing from mineral oil
- Paints can be dissolved
- Care required with material compatibility (e.g. do not use any zinc containing materials)
- Density > 1,100 kg/m³ possible design changes
- Price?

HETG (Vegetable-based fluids)

- + Mixable with mineral oils
- + Normal sealing material are compatible (e.g. NBR or FKM)
- + Good lubricating properties
- + Paint resistant to fluid
- + Viscosity changes with temperature are moderate
- Limited temperature range (-25° C to +70°C)
- Max. temperature not to be exceeded
- Limited lifetime
- UV and ozone sensitive
- Beware of water take-up (cracking?)
- Price?

HEES (Synthetic ester based fluids)

- + Wide temperature range (-30° C ... +90° C or over 100° C with some variants)
- + Good lifetime
- + Mixable with mineral oils
- + Normal sealing materials compatible (FKM and NBR recommended)
- + Machine paints resistant to fluid
- + Viscosity changes with temperature are moderate
- + Good lubricating properties
- Danger of hydrolysis with water take-up (filters, dryer, occlusion)
- Price?

Compatibility

Generally, HPCE steel fittings with standard NBR seals are suitable for most applications.

	-20 °C ... 80 °C	80 °C ... 120 °C
HEPG Polyalkylenglycol	NBR FKM	Not suitable for Oil
HETG Vegetable Oil	NBR FKM	- FKM
HEES Synthetic ester	NBR FKM	- FKM

Suitable sealing compounds

Experience shows that media compatibility is not a critical issue for static seals used on tube fittings. In doubt please contact HPCE application engineering.

Pragmatic approach

If there is doubt about switching over to softseal fitting systems (ISO6149/Eolastic/O-Lok®/EO-2), it might be a good idea to have a close look on the existing hydraulic system. If NBR seals perform well on hoses, cylinders, valves or filters there is nothing to worry about standard HPCE fittings. Usually the design engineers know when special seal compounds like FKM have to be used.

Flow characteristics

Hydraulic systems are in most cases only rated with a flow velocity defined on the basis of experience. The pressure losses in lines are not taken into account, or measured later on when testing the system. As the pressure losses increase proportionally greater than the flow resistance, it is important to achieve the best rating of the system, that they are already taken into account when planning the tube connections. Calculation is not as difficult as it is often thought, and this chapter is intended to provide a guideline. Besides, it provides information on how excessive pressure losses can be avoided, because pressure losses result in losses in performance and excessive heat. Noise occurs, and possibly cavitation in suction lines.

Medium

All indication given with regard to flow restrictions and to flow properties refer exclusively to liquids. For gaseous media, the variable density of the gas must additionally be taken into account.

Units

c = Flow velocity $\left[\frac{\text{m}}{\text{s}}\right]$

d = Pipe inside diameter [m]

L = Pipe length [m]

ρ = Pressure [Pa], 1 bar = 100000 Pa

\dot{V} = Flow rate $\left[\frac{\text{m}^3}{\text{s}}\right]$, $1 \frac{\text{m}^3}{\text{s}} = 60000 \frac{\text{l}}{\text{min}}$

λ = Pipe friction factor

$\nu(T)$ = Kinematic viscosity of the medium depending on temperature $\left[\frac{\text{m}^2}{\text{s}}\right]$

$\rho(T)$ = Density of the medium depending on temperature $\left[\frac{\text{kg}}{\text{m}^3}\right]$

ζ = Individual pressure loss coefficient

Only base units have been used. This has the advantage that the formula do not contain correction factors and there is no danger of confusion, e.g. that values are used with the wrong unit. In case values are given in other units – the flow rate is e.g. often given in l/min – it is advisable to convert them into the base units before starting calculation.

Pressure losses in pipe lines

To calculate pressure losses in pipe lines, it must first be determined whether there is a laminar or a turbulent flow. Laminar flow is homogenous and without turbulence. In case of turbulent flow, the losses increase much more quickly.

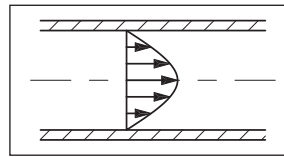

Flow profile with laminar flow

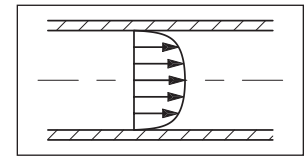

Flow profile with turbulent flow

The kind of flow is defined by the Reynolds' number. With a Reynolds' number of more than 2320, the flow changes to turbulent. The Reynold number is calculated according to the formula:

$$Re = \frac{c \cdot d}{\nu(T)}$$

The Reynolds' number is a non-dimensional number. The critical fluid velocity at which the flow regime can change, is thus calculated from:

$$c_{cr} = 2320 \cdot \frac{\nu(T)}{d} \left[\frac{\text{m}}{\text{s}}\right]$$

With a given flow rate, the fluid velocity can be calculated according to the formula:

$$c = \frac{\dot{V} \cdot 4}{d^2 \cdot \pi} \left[\frac{\text{m}}{\text{s}}\right]$$

Subsequently, the pipe friction factor λ can be calculated. The pipe friction factor λ is a function of the Reynold number and also depends on the roughness of the pipe. As hydraulically smooth pipes can generally be assumed in hydraulic applications, the pipe friction factor λ is calculated according to the following formula:

$$\text{laminar flow, } (Re < 2320): \lambda = \frac{64}{Re}$$

$$\text{turbulent flow, } (Re < 2320): \lambda = \frac{0.3164}{\sqrt[4]{Re}}$$

Finally, if all factors are known, the pressure loss in a certain pipe line can be calculated according to the formula:

$$\Delta p = \lambda \cdot \frac{L}{d} \cdot \frac{\rho(T) \cdot c^2}{2} \text{ [Pa]}$$

Calculation of individual losses

A hydraulic system does not only incorporate pipes, but also valves, fittings, pipe bends etc. that cause flow losses. These individual losses are often much higher than the pipe losses and are calculated according to the following formula:

$$\Delta p = \zeta \cdot \rho(T) \cdot \frac{c^2}{2} \text{ [Pa]}$$

Performance data

The pressure loss coefficient ζ relates to an individual hydraulic component. It covers circulation, impact and separation losses of the flow in a component. In most cases, valve or fitting manufacturers state the pressure loss coefficient of their products. The ζ values are not completely constant. The values increase in the case of very low fluid velocities. The following diagram shows the typical course of the ζ values for a component, depending on the fluid velocity, as it has been determined through a series of tests in the laboratory of the Parker Hannifin GmbH & Co. KG.

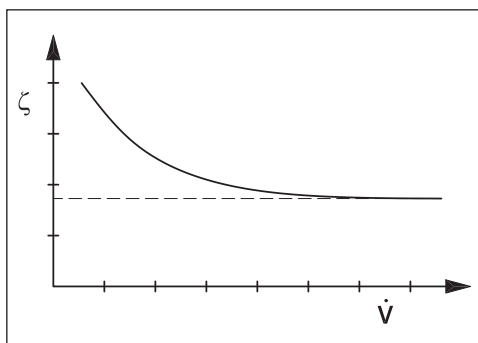

As only the flow resistances at nominal power, i.e. at higher fluid velocities, are generally calculated to rate a hydraulic plant, they may therefore be slight variations for individual sizes.

Straight fittings, e.g. G, GE, EGE, HMTX, F...MTX, F6...MX, HMLO, F...MLO, F6...MLO, ...

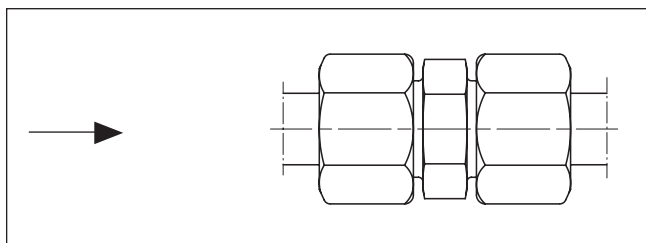

If there is a step change between the bore of the fitting and the inside diameter of the pipe, the conditions applicable to reducers (see below) are valid.

In a normal case, however, the pressure loss is very small, so that it cannot be measured by normal methods.

Literature gives a pressure loss coefficient of 0.01 to 0.05.

Reducers, e.g. RED, GR, TRMTX, TRMLO, ...

With reducers, distinction must be made between a cross section increase or reduction. The fluid velocity taken as a basis to calculate the pressure loss is always the velocity at the outlet of the flow.

Extension of the cross section:

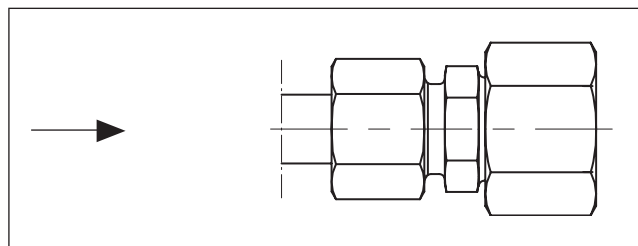

$$\zeta = \left(\frac{A_2}{A_1} - 1 \right)^2$$

With A_1 ... Inlet cross section area

A_2 ... Outlet cross section area

The formula stated is valid for a transition angle $> 60^\circ$, and thus also for EO fittings.

It is difficult to state a figure, as the program of reducers is extensive.

With an RED style of fitting, the pressure loss coefficient ζ can vary between 1.5 and 5000, always referred to the flow velocity at the outlet.

Reduction of the cross section:

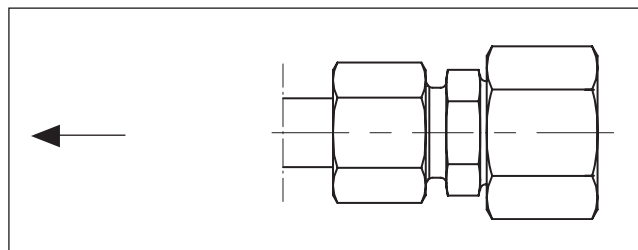

A_2/A_1	0.80	0.60	0.40	0.20
ζ	0.15	0.25	0.35	0.42

Elbow connectors, e.g. W, EW, EMTX, C...MTX, EMLO, C...MLO, ...

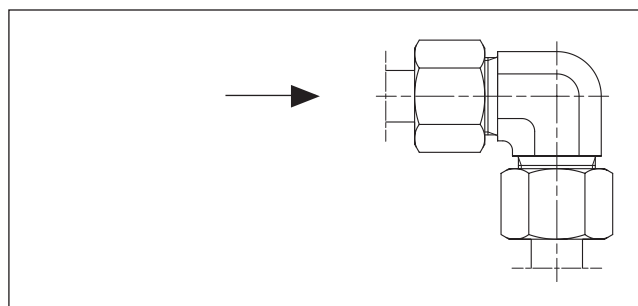

Type	Pressure loss coefficient ζ
W, EMTX, EMLO	1
EW, C...MTX, C...MLO	1

Tube bends

With pipe bends, the pressure loss coefficient results from the ratio of bend radius to inside diameter (R/d).

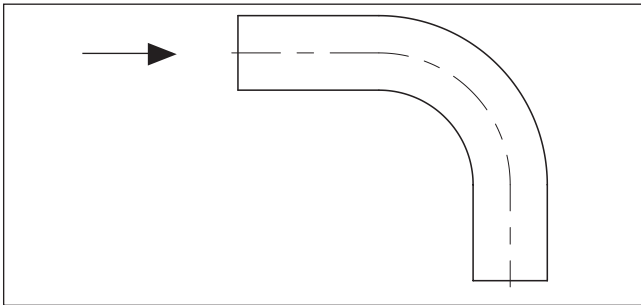

Bend radius/Inside diameter	Pressure loss coefficient ζ
2	0.21
4	0.14
6 and more	0.11

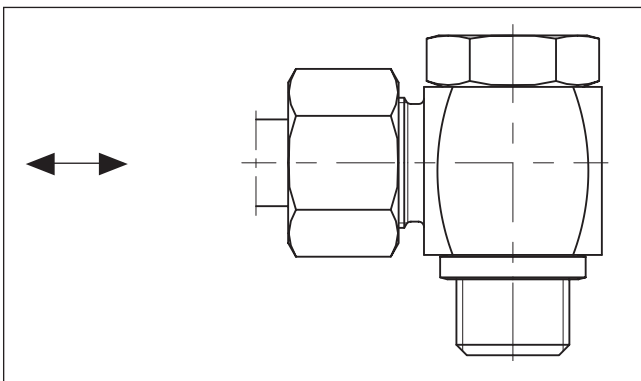
Banjo fittings

Type	Pressure loss coefficient ζ
WH	3 ... 6
SWVE	6 ... 9
DSWV	approx. 4

With WH and SWVE, the pressure loss depends on the position of the banjo bolt cross hole drilling to the tube connection aperture. The pressure loss coefficient is therefore given as a range.

Manifolds and Tee/Cross fittings

The pressure loss coefficient depends on whether the medium is divided or flows together, and in what ratio the medium is divided.

Index a: The medium flows straight through the manifold.
Index b: The medium flows through the cross branch of the manifold.

Flow division (to/from T branch)	Pressure loss coefficient ζ in case of pipe branching		Pressure loss coefficient ζ in case of pipe junction	
	\dot{V}_b / \dot{V}	ζ_a	ζ_b	ζ_a
0.6	0.07	0.95	0.40	0.47
0.8	0.20	1.10	0.50	0.73
1.0	0.35	1.30	0.60	0.92

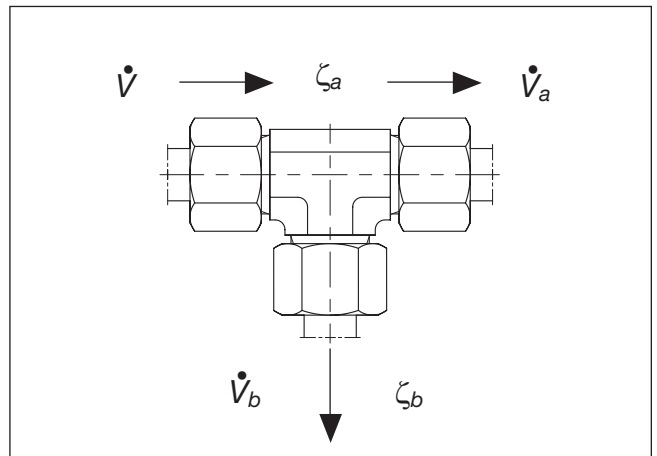

Pipe branching

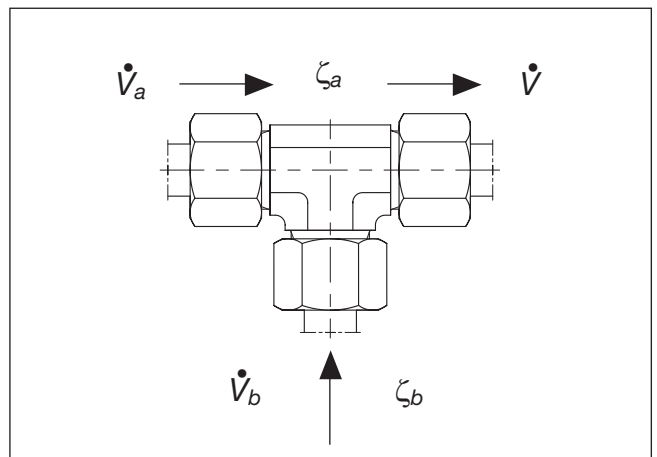

Pipe junction

Performance data

Valves, e.g. RHD, DV, VDHA, ...

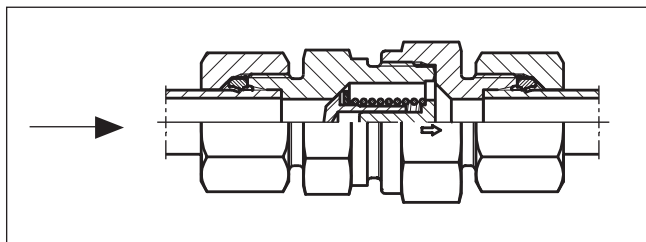

Type	Pressure loss coefficient ζ
RH ...	5.0
DV	5.5
LD	4.0
VDHA	5.0
VDHB	5.5

The pressure loss coefficient stated is always valid for the fully opened valve.

Calculation of the pressure loss Δp – example a WH 16-SR/CF (Banjo fitting).

The pressure loss Δp is calculated according to the following formula:

$$\Delta p = \zeta \cdot \rho(T) \cdot \frac{c^2}{2} \text{ [Pa]}$$

To calculate pressure loss at a flow rate of 20 l/min is to be calculated.

The following values are known:

Pipe inside diameter $d = 12 \text{ mm} = 0.012 \text{ m}$

Density of the medium $\rho = 869,4 \text{ kg/m}^3$

(Oil manufacturer's data sheet)

Pressure loss coefficient $\zeta = 4.5$

(Average value for WH fittings)

$$\text{Flow rate } \dot{V} = \left[\frac{20}{60000} \right] = 0.000333 \left[\frac{\text{m}^3}{\text{s}} \right]$$

$$\text{Fluid velocity } c = \frac{\dot{V} \cdot 4}{d_2 \cdot \pi} = \frac{0.000333 \cdot 4}{0.012^2 \cdot \pi} = 2.95 \left[\frac{\text{m}}{\text{s}} \right]$$

The thus resulting flow loss is then:

$$\Delta p = 4.5 \cdot 869,4 \cdot \frac{2.95^2}{2} = 17000 \text{ [Pa]} = 0.17 \text{ [bar]}$$

Flow diameter and wall thickness

Determining tube size for hydraulic systems

Proper tube material, type and size for a given application and type of fitting is critical for efficient and trouble free operation of the fluid system. Selection of proper tubing involves choosing the right tube material, and determining the optimum tube size (O.D. and wall thickness).

Proper sizing of the tube for various parts of a hydraulic system results in an optimum combination of efficient and cost effective performance.

A tube that is too small causes high fluid velocity, which has many detrimental effects. In pressure lines, it causes high friction losses and turbulence, both resulting in high pressure drops and heat generation. High heat accelerates wear in moving parts and rapid aging of seals and hoses, all resulting in reduced component life. High heat generation also means wasted energy, and hence, low efficiency.

Too large tubes increase system cost. Thus, optimum tube sizing is very critical. The following is a simple procedure for sizing the tubes.

Determine required flow diameter

Use table to determine recommended flow diameter for the required flow rate and type of line.

The table is based on the following recommended flow velocities:

$$\text{Pressure lines} - 3 \rightarrow 5 \left[\frac{\text{m}}{\text{s}} \right]$$

Avoid flow rates > 8 m/s!
The resulting forces are high and can destroy the tube lines.

$$\text{Return lines} - 2 \rightarrow 4 \left[\frac{\text{m}}{\text{s}} \right]$$

$$\text{Suction lines} - 1 \left[\frac{\text{m}}{\text{s}} \right]$$

If you desire to use different velocities than the above, use one of the following formula to determine the required flow diameter.

$$\text{Tube-I.D. [mm]} = 4.61 \sqrt{\frac{\text{Flow} \left[\frac{\text{ltr.}}{\text{min}} \right]}{\text{Velocity} \left[\frac{\text{m}}{\text{s}} \right]}}$$

Determine required wall thickness

Use 2nd table to determine recommended wall thickness for the required working pressure and flow diameter of the line. Therefore choose an working pressure which is equal or higher than the required working pressure.

For other tubes and tube materials you have to calculate the wall thickness and working pressure acc. to the formula shown in the tube chapter.

Maximum flow l/min	Flow diameter in millimeters		
	5 m/s Pressure lines	3 m/s Return lines	1 m/s Suction lines
1	2.1	2.7	4.6
2	2.9	3.8	6.5
3	3.6	4.6	8.0
4	4.1	5.3	9.2
5	4.6	6.0	10.3
6	5.1	6.5	11.3
7	5.5	7.0	12.2
8	5.8	7.5	13.0
9	6.2	8.0	13.8
10	6.5	8.4	14.6
12	7.1	9.2	16.0
14	7.7	10.0	17.2
16	8.2	10.6	18.4
18	8.7	11.3	19.6
20	9.2	11.9	20.6
22	9.7	12.5	21.6
24	10.1	13.0	22.6
26	10.5	13.6	23.5
28	10.9	14.1	24.4
30	11.3	14.6	25.3
32	11.7	15.1	26.1
34	12.0	15.5	26.9
36	12.4	16.0	27.7
38	12.7	16.4	28.4
40	13.0	16.8	29.2
45	13.8	17.9	30.9
50	14.6	18.8	32.6
55	15.3	19.7	34.2
60	16.0	20.6	35.7
65	16.6	21.5	37.2
70	17.2	22.3	38.6
75	17.9	23.1	39.9
80	18.4	23.8	41.2
85	19.0	24.5	42.5
90	19.6	25.3	43.7
95	20.1	25.9	44.9
100	20.6	26.6	46.1
110	21.6	27.9	48.4
120	22.6	29.2	50.5
130	23.5	30.3	52.6
140	24.4	31.5	54.5
150	25.3	32.6	56.5
160	26.1	33.7	58.3
170	26.9	34.7	60.1
180	27.7	35.7	61.8
190	28.4	36.7	63.5
200	29.2	37.6	65.2
220	30.6	39.5	68.4
240	31.9	41.2	71.4
260	33.2	42.9	74.3
280	34.5	44.5	77.1
300	35.7	46.1	79.8
320	36.9	57.6	82.5
340	38.0	49.1	85.0
360	39.1	50.5	87.5
380	40.2	51.9	89.9
400	41.2	53.2	92.2
450	43.7	56.5	97.8
500	46.1	59.5	103.1





Dimensioning

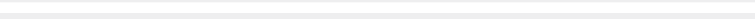

Index

Overview EO 24° cone connections	D3
Not recommended	D4
EO 24° cone end (DIN 3861/ISO 8434-1)/dimension.....	D4
EO 24°-DKO swivel connector (DIN 3865/DIN EN ISO 8434-1/-4)/dimensions	D5
Overview O-Lok® connections.....	D6–D7
O-Lok® end (ISO 8434-3/SAE J1453)/dimensions	D8
O-Lok® swivel connector (ISO 8434-3/SAE J1453)/dimensions	D9
Overview Triple-Lok® connections.....	D10–D11
Triple-Lok® end (ISO 8434-2/SAE J514)/dimensions	D12
Triple-Lok® swivel connector (ISO 8434-3/SAE J514)/dimensions	D13
DIN 60° cone end (DIN 7631)/dimensions	D14
Adapter 60° cone end (ISO/DIS 8434-6)/dimensions	D15
NPSM Swivel adapters (SAE J516)/dimensions	D16
Port end dimensions for tube fittings.....	D17–D19

Overview EO 24° cone connections

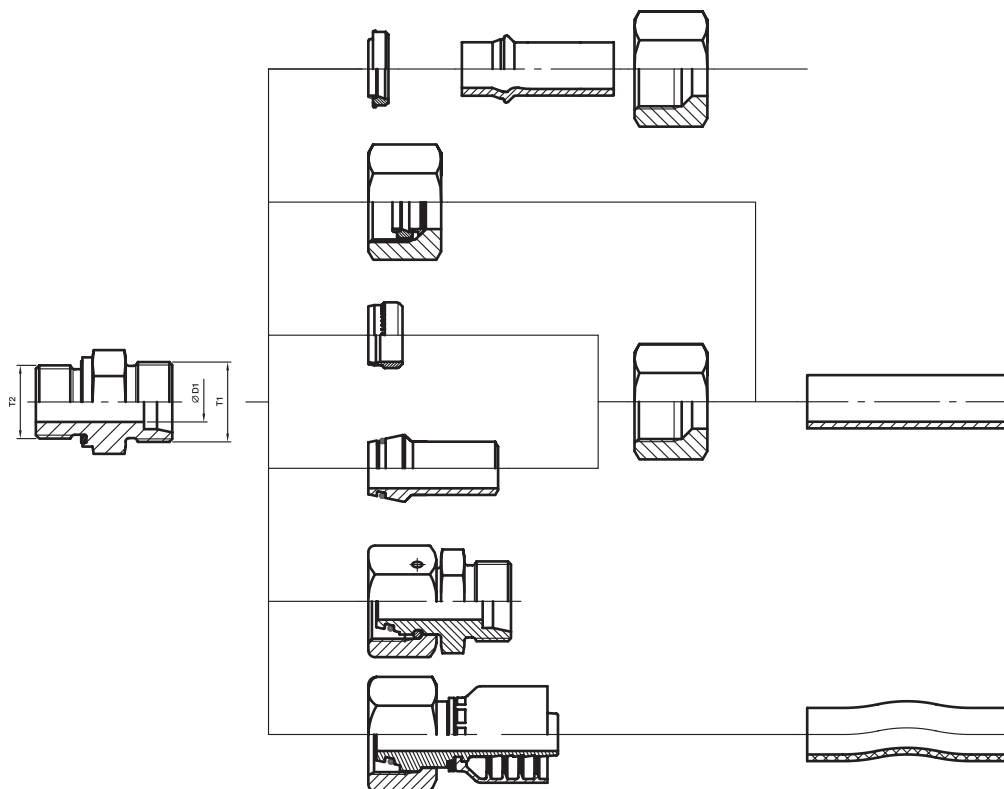

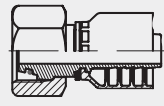
Size	D1 Tube O.D. mm	T1 Thread metric	Thread O.D. mm	T2 Port thread				
				BSP	metric	BSPT (short)	metric tapered	
LL	04	M 08×1.0	8.0	G 1/8 A	M 08×1.0	R 1/8 tap.	M 08×1.0 tap.	
	05	M 10×1.0	10.0	G 1/8 A	M 08×1.0			
	06	M 10×1.0	10.0	G 1/8 A	M 10×1.0	R 1/8 tap.	M 10×1.0 tap.	
	08	M 12×1.0	12.0	G 1/8 A	M 10×1.0	R 1/8 tap.	M 10×1.0 tap.	
	10	M 14×1.0	14.0	G 1/4 A		R 1/4 tap.		
	12	M 16×1.0	16.0	G 1/4 A		R 1/4 tap.		
L	06	M 12×1.5	12.0	G 1/8 A	M 10×1.0		M 10×1.0 tap.	1CAxx-6-yy
	08	M 14×1.5	14.0	G 1/4 A	M 12×1.5		M 12×1.5 tap.	1CAxx-8-yy
	10	M 16×1.5	16.0	G 1/4 A	M 14×1.5		M 14×1.5 tap.	1CAxx-10-yy
	12	M 18×1.5	18.0	G 3/8 A	M 16×1.5		M 16×1.5 tap.	1CAxx-12-yy
	15	M 22×1.5	22.0	G 1/2 A	M 18×1.5		M 18×1.5 tap.	1CAxx-15-yy
	18	M 26×1.5	26.0	G 1/2 A	M 22×1.5		M 22×1.5 tap.	1CAxx-18-yy
	22	M 30×2.0	30.0	G 3/4 A	M 26×1.5		M 26×1.5 tap.	1CAxx-22-yy
	28	M 36×2.0	36.0	G 1 A	M 33×2.0			1CAxx-28-yy
	35	M 45×2.0	45.0	G 1 1/4 A	M 42×2.0			1CAxx-35-yy
	42	M 52×2.0	52.0	G 1 1/2 A	M 48×2.0			1CAxx-42-yy
S	06	M 14×1.5	14.0	G 1/4 A	M 12×1.5		M 12×1.5 tap.	1C9xx-6-yy
	08	M 16×1.5	16.0	G 1/4 A	M 14×1.5		M 14×1.5 tap.	1C9xx-8-yy
	10	M 18×1.5	18.0	G 3/8 A	M 16×1.5		M 16×1.5 tap.	1C9xx-10-yy
	12	M 20×1.5	20.0	G 3/8 A	M 18×1.5		M 18×1.5 tap.	1C9xx-12-yy
	14	M 22×1.5	22.0	G 1/2 A	M 20×1.5		M 20×1.5 tap.	1C9xx-14-yy
	16	M 24×1.5	24.0	G 1/2 A	M 22×1.5		M 22×1.5 tap.	1C9xx-16-yy
	20	M 30×2.0	30.0	G 3/4 A	M 27×2.0			1C9xx-20-yy
	25	M 36×2.0	36.0	G 1 A	M 33×2.0			1C9xx-25-yy
	30	M 42×2.0	45.0	G 1 1/4 A	M 42×2.0			1C9xx-30-yy
	38	M 52×2.0	52.0	G 1 1/2 A	M 48×2.0			1C9xx-38-yy

xx – Fitting Series • yy – Hose Size
From Parker hose fitting (PHDE)

Dimensioning

Not recommended

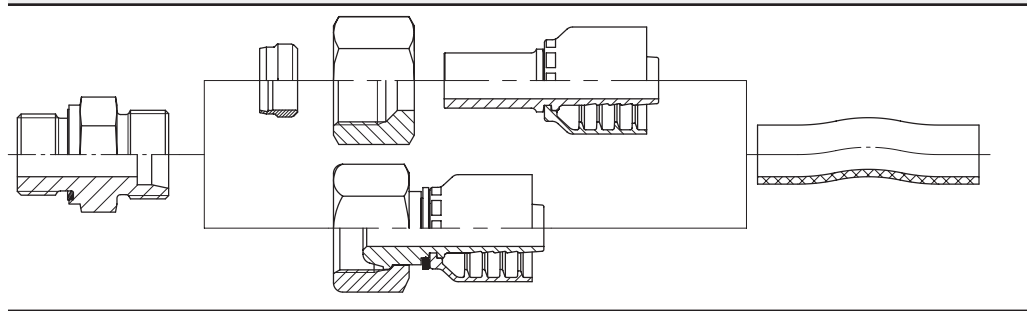
	Reason
	<p>High risk of hose blow off. For ferrule assembly special hardened tools are required.</p> <p>With the use of the Universal-connection high risk of cracks in 24° cone area of stud ends sizes 6-L up to 18-L.</p>

EO 24° cone end (DIN 3861/ISO 8434-1)/dimension

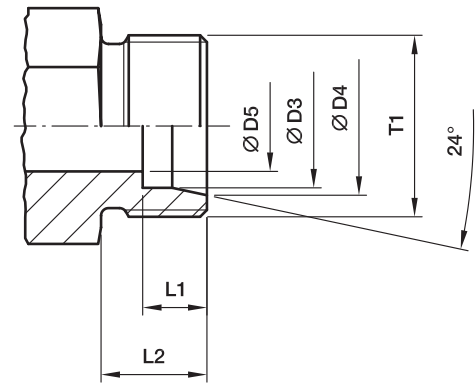

Tube O.D. Size	T1	Ø D3 mm	Ø D4 mm	Ø D5 mm	L1 mm	L2 mm
04-LL	M 08x1.0	04	5.0	3.0	4.1	8
06-LL	M 10x1.0	06	7.5	4.5	5.6	8
08-LL	M 12x1.0	08	9.5	6.0	5.6	9
10-LL	M 14x1.0	10	11.5	8.0	5.6	9
12-LL	M 16x1.0	12	13.5	10.0	6.1	9
06-L	M 12x1.5	06	8.1	4.0	7.1	10
08-L	M 14x1.5	08	10.1	6.0	7.1	10
10-L	M 16x1.5	10	12.3	8.0	7.1	11
12-L	M 18x1.5	12	14.3	10.0	7.1	11
15-L	M 22x1.5	15	17.3	12.0	7.1	12
18-L	M 26x1.5	18	20.3	15.0	7.6	12
22-L	M 30x2.0	22	24.3	19.0	7.6	14
28-L	M 36x2.0	28	30.3	24.0	7.6	14
35-L	M 45x2.0	35	38.0	30.0	10.6	16
42-L	M 52x2.0	42	45.0	36.0	11.1	16
06-S	M 14x1,5	06	8.1	4.0	7.1	12
08-S	M 16x1.5	08	10.1	5.0	7.1	12
10-S	M 18x1.5	10	12.3	7.0	7.6	12
12-S	M 20x1.5	12	14.3	8.0	7.6	12
14-S	M 22x1.5	14	16.3	10.0	8.1	14
16-S	M 24x1.5	16	18.3	12.0	8.6	14
20-S	M 30x2.0	20	22.9	16.0	10.6	16
25-S	M 36x2.0	25	27.9	20.0	12.1	18
30-S	M 42x2.0	30	33.0	25.0	13.6	20
38-S	M 52x2.0	38	41.0	32.0	16.1	22

EO 24°-DKO swivel connector (DIN 3865/DIN EN ISO 8434-4)/dimensions

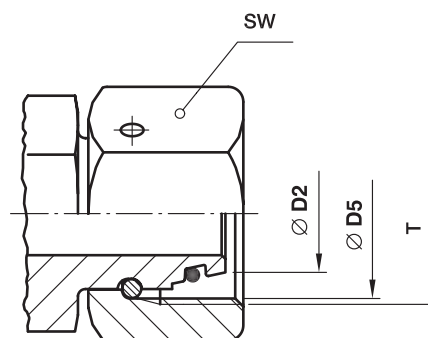

D

Tube O.D. Size	T	Ø D2 mm	Ø D5 mm Thread core diameter	SW mm
06-L	M 12×1.5	5.5	10.38	14
08-L	M 14×1.5	7.5	12.38	17
10-L	M 16×1.5	9.7	14.38	19
12-L	M 18×1.5	11.7	16.38	22
15-L	M 22×1.5	14.7	20.38	27
18-L	M 26×1.5	17.7	24.38	32
22-L	M 30×2.0	21.7	27.84	36
28-L	M 36×2.0	27.7	33.84	41
35-L	M 45×2.0	34.5	42.84	50
42-L	M 52×2.0	41.5	49.84	60
06-S	M 14×1.5	5.5	12.38	17
08-S	M 16×1.5	7.5	14.38	19
10-S	M 18×1.5	9.7	16.38	22
12-S	M 20×1.5	11.7	18.38	24
14-S	M 22×1.5	13.5	20.38	27
16-S	M 24×1.5	15.5	22.38	30
20-S	M 30×2.0	19.5	29.84	36
25-S	M 36×2.0	24.5	33.84	46
30-S	M 42×2.0	29.5	39.84	50
38-S	M 52×2.0	37.5	49.84	60

Overview O-Lok® connections

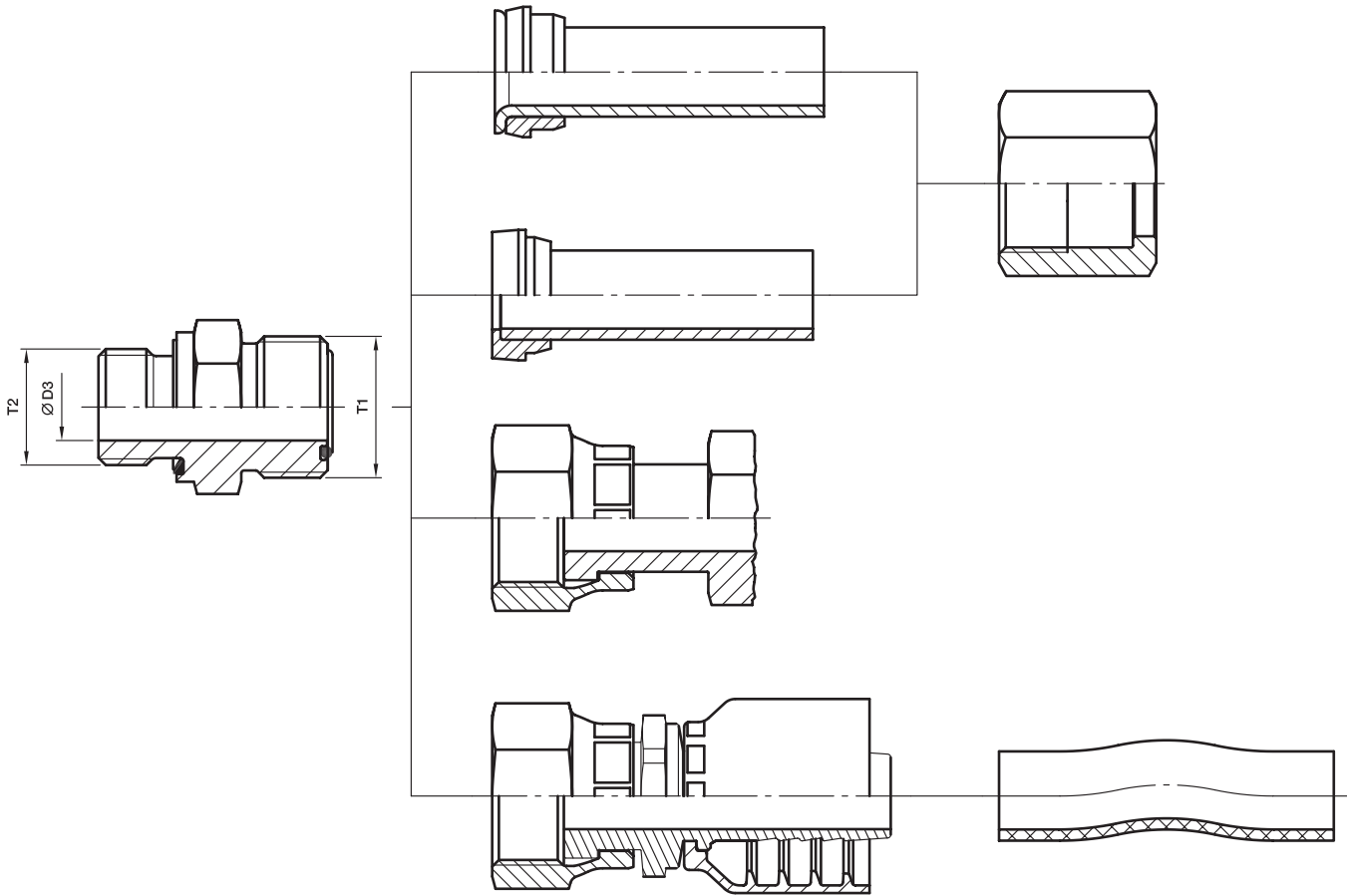

Overview O-Lok® connections

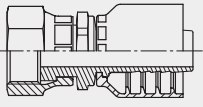
Size	Tube				T1 Thread UN/UNF	Ø D3 Bore diameter mm	T2 Port thread				
	Metric tube		Inch tube				BSP	UN/UNF	NPTF	metric	
	O.D. mm	max. Wall thickness mm	O.D. inch	max. Wall thickness inch							
4	6	1.5	1/4	0.065		4.0	G 1/8 A	7/16-20	1/8	M 12×1.5	1JCxx-4-yy
4-4	6	1.5	1/4	0.065		4.5	G 1/4 A		1/4		
4-6	6	1.5	1/4	0.065	9/16-18	4.5	G 3/8 A	9/16-18	3/8		
4-8	6	1.5	1/4	0.065		4.5	G 1/2 A	3/4-16			
6	8	2.0	5/16	0.095	11/16-16	6.5	G 1/4 A	9/16-18	1/4	M 16×1.5	1JCxx-6-yy
6	10	2.0	3/8	0.095		6.5	G 1/4 A	9/16-18	1/4	M 16×1.5	
6-2	10	2.0	3/8	0.095		4.5	G 1/8 A				
6-4	10	2.0	3/8	0.095	11/16-16	4.5		7/16-20			
6-6	10	2.0	3/8	0.095		6.5	G 3/8 A		3/8		
6-8	10	2.0	3/8	0.095		6.5	G 1/2 A	3/4-16	1/2		
6-10	10	2.0	3/8	0.095		6.5		7/8-14			
6-12	10	2.0	3/8	0.095		6.5	G 3/4 A				
8	12	3.0	1/2	0.095		9.5	G 3/8 A	3/4-16	3/8	M 18×1.5	1JCxx-8-yy
8-4	12	3.0	1/2	0.095		7.5	G 1/4 A				
8-6	12	3.0	1/2	0.095		9.5		9/16-18			
8-8	12	3.0	1/2	0.095	13/16-16	9.5	G 1/2 A	1/2-20			
8-10	12	3.0	1/2	0.095		9.5		7/8-14			
8-12	12	3.0	1/2	0.095		9.5	G 3/4 A	1 1/16-12	3/4		
8-16	12	3.0	1/2	0.095		9.5		1 5/16-12			
10	14	2.5			1-14	12.5	G 1/2 A	7/8-14	1/2	M 22×1.5	
10	15	2.5			1-14	12.5	G 1/2 A	7/8-14	1/2	M 22×1.5	1JCxx-10-yy
10	16	3.0	5/8	0.120		12.5	G 1/2 A	7/8-14	1/2	M 22×1.5	
10-6	16	3.0	5/8	0.120		10.0	G 3/8 A				
10-8	16	3.0	5/8	0.120	1-14	9.5		3/4-16			
10-12	16	3.0	5/8	0.120		12.5	G 3/4 A	1 1/16-12	3/4		
10-16	16	3.0	5/8	0.120		12.5	G 1 A				
12	18	3.0			1 3/16-12	15.5	G 3/4 A	1 1/16-12	3/4	M 27×2.0	1JCxx-20-yy
12	20	3.5	3/4	0.156		15.5	G 3/4 A	1 1/16-12	3/4	M 27×2.0	
12-8	20	3.5	3/4	0.156		9.5	G 1/2 A	3/4-16	1/2		
12-10	20	3.5	3/4	0.156	1 3/16-12	12.5		7/8-14			
12-16	20	3.5	3/4	0.156		12.5	G 1 A	1 5/16-12	1		
12-20	20	3.5	3/4	0.156		12.5	G 1 1/4 A				
16	22	4.0			1 7/16-12	20.5	G 1 A	1 5/16-12	1	M 33×2.0	1JCxx-16-yy
16	25	4.0	1	0.188		20.5	G 1 A	1 5/16-12	1	M 33×2.0	
16-12	25	4.0	1	0.188		15.5	G 3/4 A	1 1/16-12	3/4		
16-20	25	4.0	1	0.188	1 7/16-12	20.5	G 1 1/4 A	1 5/8-12			
16-24	25	4.0	1	0.188		20.5	G 1 1/2 A				
20	28	4.0			1 11/16-12	26.0	G 1 1/4 A	1 5/8-12	1 1/4	M 42×2.0	1JCxx-20-yy
20	30	4.0			1 11/16-12	26.0	G 1 1/4 A	1 5/8-12	1 1/4	M 42×2.0	
20	32	4.0	1 1/4	0.188		26.0	G 1 1/4 A	1 5/8-12	1 1/4	M 42×2.0	
20-16	32	4.0	1 1/4	0.188	1 11/16-12	21.5	G 1 A	1 5/16-12			
20-24	32	4.0	1 1/4	0.188		26.0	G 1 1/2 A	1 7/8-12			
24	35	4.0			2-12	32.0	G 1 1/2 A	1 7/8-12	1 1/2	M 48×2.0	1JCxx-24-yy
24	38	5.0	1 1/2	0.220	2-12	32.0	G 1 1/2 A	1 7/8-12	1 1/2	M 48×2.0	
24-20	38	5.0	1 1/2	0.220		27.5	G 1 1/4 A	1 5/8-12			
32	50	3.0	2	0.120	2 1/2-12	45.0	G 2 A	2 1/2-12		M 60×2.0	

xx – Fitting Series • yy – Hose Size
From Parker hose fitting (HPDE and PFDE)

Dimensioning

O-Lok® end (ISO 8434-3/SAE J1453)/dimensions

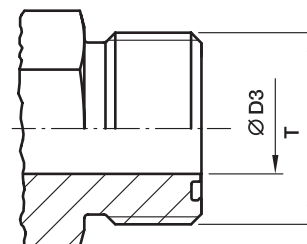

Ø D5 Size	Tube O.D.		T	T	Ø D3 mm
	inch	mm	UN/UNF	Major thread Ø mm	
4	1/4	6	9/16-18	14.0	5.0
6	5/16, 3/8	8, 10	11/16-16	17.0	6.5
8	1/2	12	13/16-16	20.5	9.5
10	5/8	14, 15, 16	1-14	25.0	12.5
12	3/4	18, 20	1 3/16-12	30.0	15.5
16	7/8, 1	22, 25	1 7/16-12	36.0	20.5
20	1 1/4	28, 30, 32	1 11/16-12	42.5	26.0
24	1 1/2	35, 38	2-12	50.5	32.0
32	2	50	2 1/2-12	63.0	45.0

All dimensions shown are nominal for identification only.

Small deviations may be found between SAE J1453 or ISO 8434-3 on bore sizes.

O-Lok® swivel connector (ISO 8434-3/SAE J1453)/dimensions

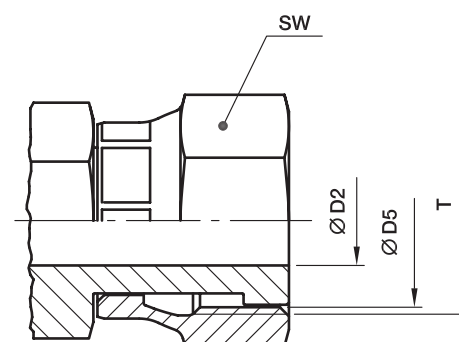

D

Size	Tube O.D.		T UN/UNF	Ø D5 Thread core diameter mm	SW mm	Ø D2 mm
	inch	mm				
4	1/4	6	9/16-18	12.5	17	4.0
6	5/16, 3/8	8, 10	11/16-16	16.0	22	6.5
8	1/2	12	13/16-16	19.0	24	9.0
10	5/8	14, 15, 16	1-14	23.0	30	11.5
12	3/4	18, 20	1 3/16-12	28.0	36	14.0
16	7/8, 1	22, 25	1 7/16-12	34.0	41	20.0
20	1 1/4	28, 30, 32	1 11/16-12	40.5	50	26.0
24	1 1/2	35, 38	2-12	48.0	60	32.0

All dimensions shown are nominal for identification only.

Small deviations may be found between SAE J1453 or ISO 8434-3 on bore sizes.

Overview Triple-Lok® connections

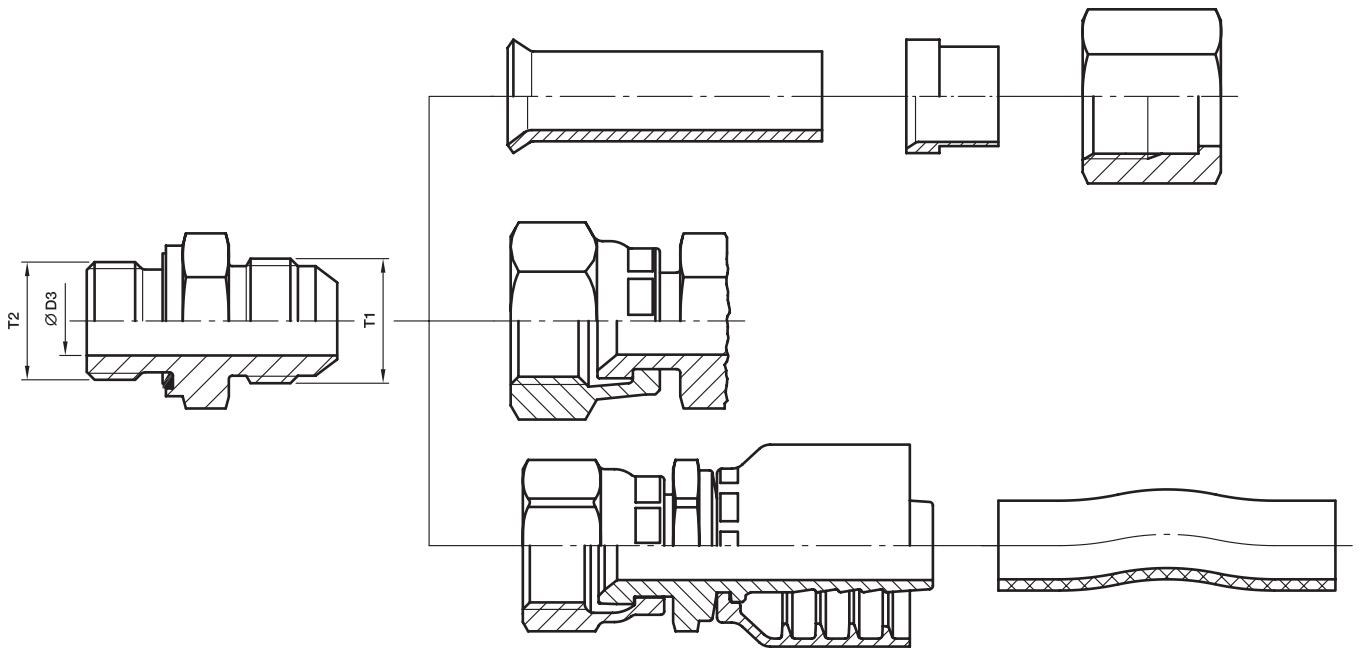

Overview Triple-Lok® connections

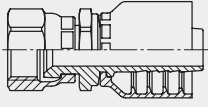
Size	Tube				T1 Thread UN/UNF	Ø D3 Bore diameter mm	T2 Port thread			
	Metric tube O.D. mm	max. Wall thickness mm	Inch tube O.D. inch	max. Wall thickness inch			BSPP (BSPT, NPTF)	UN/UNF	metric	
4	6	1.5	1/4	0.065		4.5	G 1/8 A	7/16-20	M 10×1.0	168xx-4-yy
4-4	6	1.5	1/4	0.065		4.5	G 1/4 A			
4-5	6	1.5	1/4	0.065	7/16-20	4.5		1/2-20		
4-6	6	1.5	1/4	0.065		4.5	G 3/8 A	9/16-18		
4-8	6	1.5	1/4	0.065		4.5	G 1/2 A			
5	8	1.5	5/16	0.065		6.0	G 1/8 A	1/2-20	M 12×1.5	168xx-5-yy
5-4	8	1.5	5/16	0.065		6.0	G 1/4 A			
5-6	8	1.5	5/16	0.065	1/2-20	6.0	G 3/8 A			
5-8	8	1.5	5/16	0.065		6.0	G 1/2 A			
6-2	10	1.5	3/8	0.065		7.5	G 1/8 A			106xx-6-yy
6	10	1.5	3/8	0.065		7.5	G 1/4 A	9/16-18	M 14×1.5	
6-6	10	1.5	3/8	0.065	9/16-18	7.5	G 3/8 A			
6-8	10	1.5	3/8	0.065		7.5	G 1/2 A	3/4-16		
8-4	12	2.0	1/2	0.083		10.0	G 1/4 A			168xx-8-yy
8	12	2.0	1/2	0.083		10.0	G 3/8 A	3/4-16	M 16×1.5	
8-8	12	2.0	1/2	0.083	3/4-16	10.0	G 1/2 A		M 18×1.5	
8-10	12	2.0	1/2	0.083		10.0		7/8-14		
8-12	12	2.0	1/2	0.083		10.0	G 3/4 A	1 1/16-12		
10-6	14, 15, 16	2.5	5/8	0.095		12.5	G 3/8 A			168xx-10-yy
10-8	14, 15, 16	2.5	5/8	0.095		12.5		3/4-16		
10	14, 15, 16	2.5	5/8	0.095	7/8-14	12.5	G 1/2 A	7/8-14	M 18×1.5	
10-12	14, 15, 16	2.5	5/8	0.095		12.5	G 3/4 A	1 1/16-12	M 22×1.5	
12-8	18, 20	3.0	3/4	0.109		15.5	G 1/2 A	3/4-16		106xx-12-yy
12-10	18, 20	3.0	3/4	0.109		15.5		7/8-14	M 22×1.5	
12	18, 20	3.0	3/4	0.109	1 1/16-12	15.5	G 3/4 A	1 1/16-12	M 27×2.0	
12-16	18, 20	3.0	3/4	0.109		15.5	G 1 A	1 5/16-12		
14	22	3.0	7/8	0.109	1 3/16-12	18.0	G 3/4 A	1 3/16-12	M 27×2.0	–
14-16	22	3.0	7/8	0.109		18.0	G 1 A	1 5/16-12		
16-12	25	3.0	1	0.120		21.5	G 3/4 A	1 1/16-12		106xx-16-yy
16	25	3.0	1	0.120	1 5/16-12	21.5	G 1 A	1 5/16-12	M 33×2.0	
16-20	25	3.0	1	0.120		21.5	G 1 1/4 A	1 5/8-12		
20-12	28, 30, 32	3.0	1 1/4	0.120		27.5	G 3/4 A			106xx-20-yy
20-16	28, 30, 32	3.0	1 1/4	0.120	1 5/8-12	27.5	G 1 A			
20	28, 30, 32	3.0	1 1/4	0.120		27.5	G 1 1/4 A	1 5/8-12	M 42×2.0	
24-20	35, 38	4.0	1 1/2	0.120	1 7/8-12	33.0	G 1 1/4 A			106xx-24-yy
24	35, 38	4.0	1 1/2	0.120		33.0	G 1 1/2 A	1 7/8-12	M 48×2.0	
28-24	42	3.0			2 1/4-12	39.0	G 1 1/2 A			–
32	50	3.5	2	0.134	2 1/2-12	45.0	G 2 A	2 1/2-12		106xx-32-yy

xx – Fitting Series • yy – Hose Size
From Parker hose fitting
(HPDE and PFDE)

Triple-Lok® end (ISO 8434-2/SAE J514)/dimensions

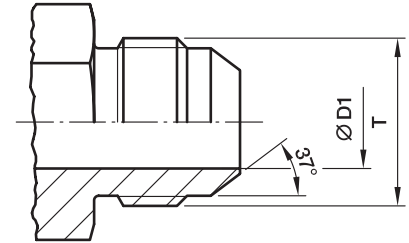

Size	Tube O.D.		T	T	Ø D1 mm
	inch	mm	UN/UNF	Major thread Ø mm	
4	1/4	6	7/16-20	11.0	4.5
5	5/16	8	1/2-20	12.5	6.0
6	3/8	10	9/16-18	14.0	7.5
8	1/2	12	3/4-16	19.0	10.0
10	5/8	14, 15, 16	7/8-14	22.0	12.5
12	3/4	18, 20	1 1/16-12	27.0	15.5
14	7/8	22	1 3/16-12	30.0	18.0
16	1	25	1 5/16-12	33.0	21.5
20	1 1/4	28, 30, 32	1 5/8-12	41.0	27.5
24	1 1/2	35, 38	1 7/8-12	47.5	33.0
28*	1 3/4	42	2 1/4-12	57.0	39.0
32	2	-	2 1/2-12	63.5	45.0

*Size 28 is not part of SAE J514 or ISO 8434-2.

All dimensions shown are nominal for identification only.
Small deviations may be found between SAE J514 or ISO 8434-2 on bore sizes.

Suitable Flare

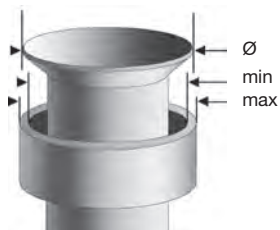

Tube O.D.		Ø D	
mm	inch	Min.	Max.
6	1/4"	8.6	9.7
8	5/16"	10.2	11.3
10	3/8"	11.7	12.7
12	1/2"	16.0	17.3
14		19.3	20.2
15		19.3	20.2
16	5/8"	19.3	20.2
18		23.4	24.7
20	3/4"	23.4	24.7
22	7/8"	26.5	27.8
25	1"	29.7	31.0
28		37.6	38.9
30		37.6	38.9
32	1 1/4"	37.6	38.9
35		43.2	45.3
38	1 1/2"	43.2	45.3
42		52.0	54.8
	2"	59.2	61.2

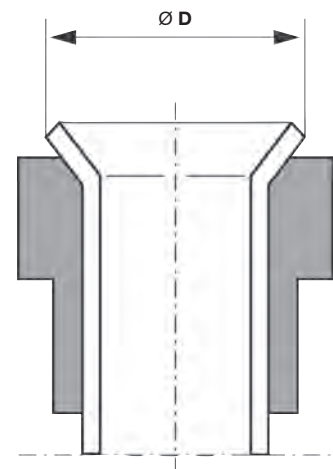

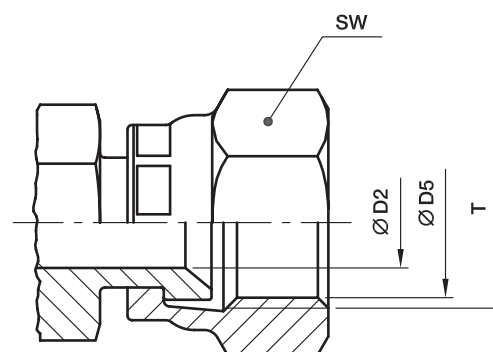
Triple-Lok[®] swivel connector (ISO 8434-2/SAE J514)/dimensions

D

Size	Tube O.D.		T UN/UNF	SW mm	Ø D5 Thread core diameter mm	Ø D2 mm
	inch	mm				
4	1/4	6	7/16-20	17	10.0	4.4
5	5/16	8	1/2-20	17	11.5	6.0
6	3/8	10	9/16-18	19	13.0	7.5
8	1/2	12	3/4-16	22	17.5	9.9
10	5/8	14, 15, 16	7/8-14	27	20.5	12.3
12	3/4	18, 20	1 1/16-12	32	25.0	15.5
14	7/8	22	1 3/16-12	35	28.0	18.0
16	1	25	1 5/16-12	38	31.0	21.5
20	1 1/4	28, 30, 32	1 5/8-12	50	39.0	27.5
24	1 1/2	35, 38	1 7/8-12	60	45.5	33.0
32	2	-	2 1/2-12	75	61.5	45.0

All dimensions shown are nominal for identification only.

Small deviations may be found between SAE J514 or ISO 8434-2 on bore sizes.

Dimensioning

DIN 60° cone end (DIN 7631)/dimensions

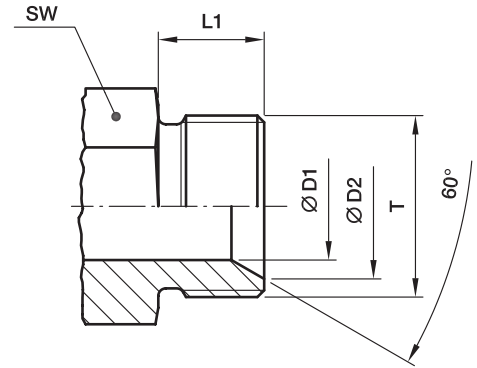

Tube O.D. mm	T	Ø D1 mm	Ø D2 mm	L1 mm	SW mm
4-5	M 10×1.5	3	8.0	8	11
06	M 12×1.5	4	9.0	10	12
08	M 14×1.5	6	11.0	10	14
10	M 16×1.5	8	13.0	11	17
12	M 18×1.5	10	15.0	11	19
15	M 22×1.5	12	19.0	12	24
18	M 26×1.5	15	22.0	12	27
22	M 30×1.5	19	26.0	14	32
28	M 38×1.5	25	33.0	14	41
35	M 45×1.5	32	40.0	16	46
42	M 52×1.5	39	47.0	16	55

Adapter 60° cone end (ISO/DIS 8434-6)/dimensions

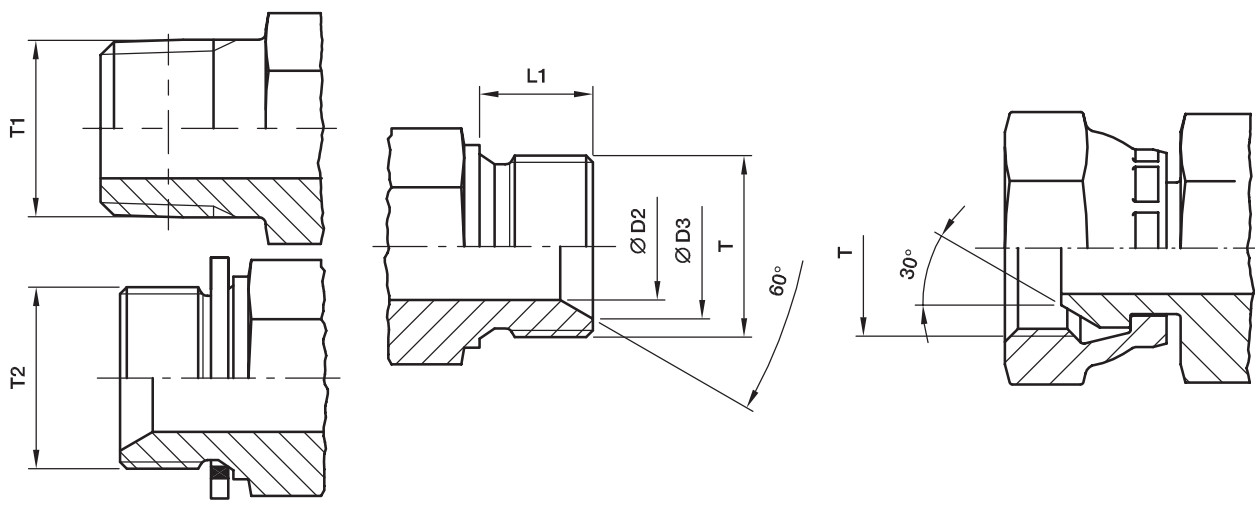

D

Size	T BSPP	D2 mm	D3 mm	L1 mm	T1		T2 BSPP
					BSPT	NPT(F)	
02	G 1/8 A	3.5	7.5	8	1/8	1/8	1/8
					1/4	1/4	
04	G 1/4 A	4.7	10.4	11	1/4	1/4	1/4
					1/8	1/8	
					3/8	3/8	
06	G 3/8 A	7.9	14.0	12	3/8	3/8	3/8
					1/4	1/4	
					1/2	1/2	
08	G 1/2 A	11.1	17.5	14	1/2	1/2	1/2
					3/8	3/8	
						3/4	
10	G 5/8 A	14.3	19.3	16	1/2		1/2
					3/4		
12	G 3/4 A	16.7	22.9	16	3/4	3/4	3/4
					1/2	1/2	
					1	1	
16	G 1 A	22.2	28.7	19	1	1	1
					3/4	3/4	
20	G 1 1/4 A	28.6	36.8	22	1 1/4		3/4
24	G 1 1/2 A	33.3	42.7	22	1 1/2		1
32	G 2 A	46.0	54.6	25			1 1/2

Dimensioning

NPSM Swivel adapters (SAE J516)/dimensions

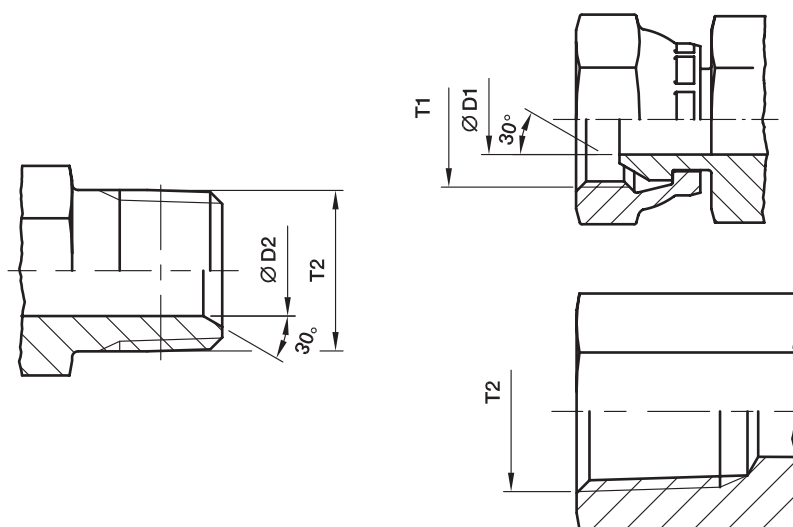

Size	T1 Thread NPSM	Ø D1 mm	Ø D2 mm	T2 Thread NPTF
2-2	1/8-27	4.0	5.0	1/8-27
2-4	1/4-18	5.6	7.0	1/8-27
4-4	1/4-18	5.6	7.0	1/4-18
4-6	3/8-18	8.8	10.0	1/4-18
4-8	1/2-14	12.0	13.5	1/4-18
6-4	1/4-18	5.6	7.0	3/8-18
6-6	3/8-18	8.8	10.0	3/8-18
6-8	1/2-14	12.0	13.5	3/8-18
8-4	1/4-18	5.6	7.0	3/4-16
8-6	3/8-18	8.8	10.0	1/2-14
8-8	1/2-14	12.0	13.5	1/2-14
8-12	3/4-14	16.3	18.0	1/2-14
10-6	3/8-18	8.8	10.0	7/8-14
10-8	1/2-14	12.0	13.5	7/8-14
10-12	3/4-14	16.3	18.0	7/8-14
12-6	3/8-18	8.8	10.0	3/4-14
12-8	1/2-14	12.0	13.5	3/4-14
12-12	3/4-14	16.3	18.0	3/4-14
12-16	1-11.5	21.4	28.9	
16-12	3/4-14	16.3	13.5	1-11.5
16-16	1-11.5	21.4	28.9	1-11.5
16-20	1 1/4-11.5	29.0	32.0	1-11.5
20-16	1-11.5	21.4	28.9	1 1/4-11.5
20-20	1 1/4-11.5	29.0	32.0	1 1/4-11.5
24-24	1 1/2-11.5	34.5	38.0	1 1/2-11.5
32-32	2-11.5	46.0	49.0	2-11.5

Male stud ends/Port end dimensions for tube fittings

Preferred male stud ends for hydraulic applications

For new designs the metric version is recommended according to DIN ISO 6149

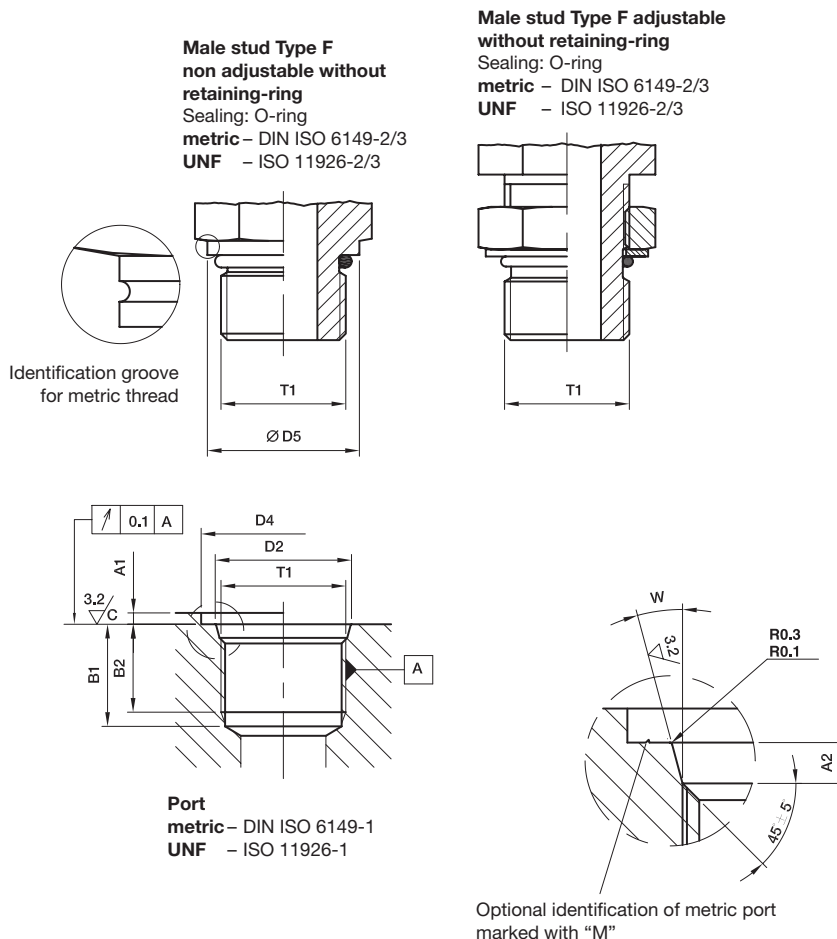

Thread T1	D5	D4		D2 0.1	A1 max.	A2 0.4	B1 min.	B2 min.	W ± 1°	Identification internal	
		small min.	wide min.							Thread major diameter	Thread minor diameter
M 08×1.0	11.8	14	17	9.10	1.0	1.6	11.5	10.0	12°	8.00	6.92
M 10×1.0	13.8	16	20	11.10	1.0	1.6	11.5	10.0	12°	10.00	8.92
M 12×1.5	16.8	19	23	13.80	1.5	2.4	14.0	11.5	15°	12.00	10.38
M 14×1.5	18.8	21	25	15.80	1.5	2.4	14.0	11.5	15°	14.00	12.38
M 16×1.5	21.8	24	28	17.80	1.5	2.4	15.5	13.0	15°	16.00	14.38
M 18×1.5	23.8	26	30	19.80	2.0	2.4	17.0	14.5	15°	18.00	16.38
M 22×1.5	26.8	29	34	23.80	2.0	2.4	18.0	15.5	15°	22.00	20.38
M 27×2.0	31.8	34	40	29.40	2.0	3.1	22.0	19.0	15°	27.00	24.84
M 33×2.0	40.8	43	49	35.40	2.5	3.1	22.0	19.0	15°	33.00	30.84
M 42×2.0	49.8	52	60	44.40	2.5	3.1	22.5	19.5	15°	42.00	39.84
M 48×2.0	54.8	57	66	50.40	2.5	3.1	25.0	22.0	15°	48.00	45.84
7/16-20 UNF-2B	13.8	21	–	12.40	1.6	2.4	14.0	11.5	12°	11.11	9.74
1/2-20 UNF-2B	16.8	23	–	14.50	1.6	2.5	14.0	11.5	12°	12.70	11.30
9/16-18 UNF-2B	16.8	25	–	15.65	1.6	2.5	15.5	12.7	12°	14.29	12.76
3/4-16 UNF-2B	21.8	30	–	20.60	2.4	2.5	17.5	14.3	15°	19.05	17.33
7/8-14 UNF-2B	26.8	34	–	23.95	2.4	2.5	20.0	16.7	15°	22.23	20.26
1 1/16-12 UN-2B	31.8	41	–	29.15	2.4	3.3	23.0	19.0	15°	26.99	24.69
1 5/16-12 UN-2B	40.8	49	–	35.50	3.2	3.3	23.0	19.0	15°	33.34	31.04
1 5/8-12 UN-2B	49.8	58	–	43.50	3.2	3.3	23.0	19.0	15°	41.28	38.99
1 7/8-12 UN-2B	54.8	65	–	49.85	3.2	3.3	23.0	19.0	15°	47.63	45.33

Port end dimensions for tube fittings

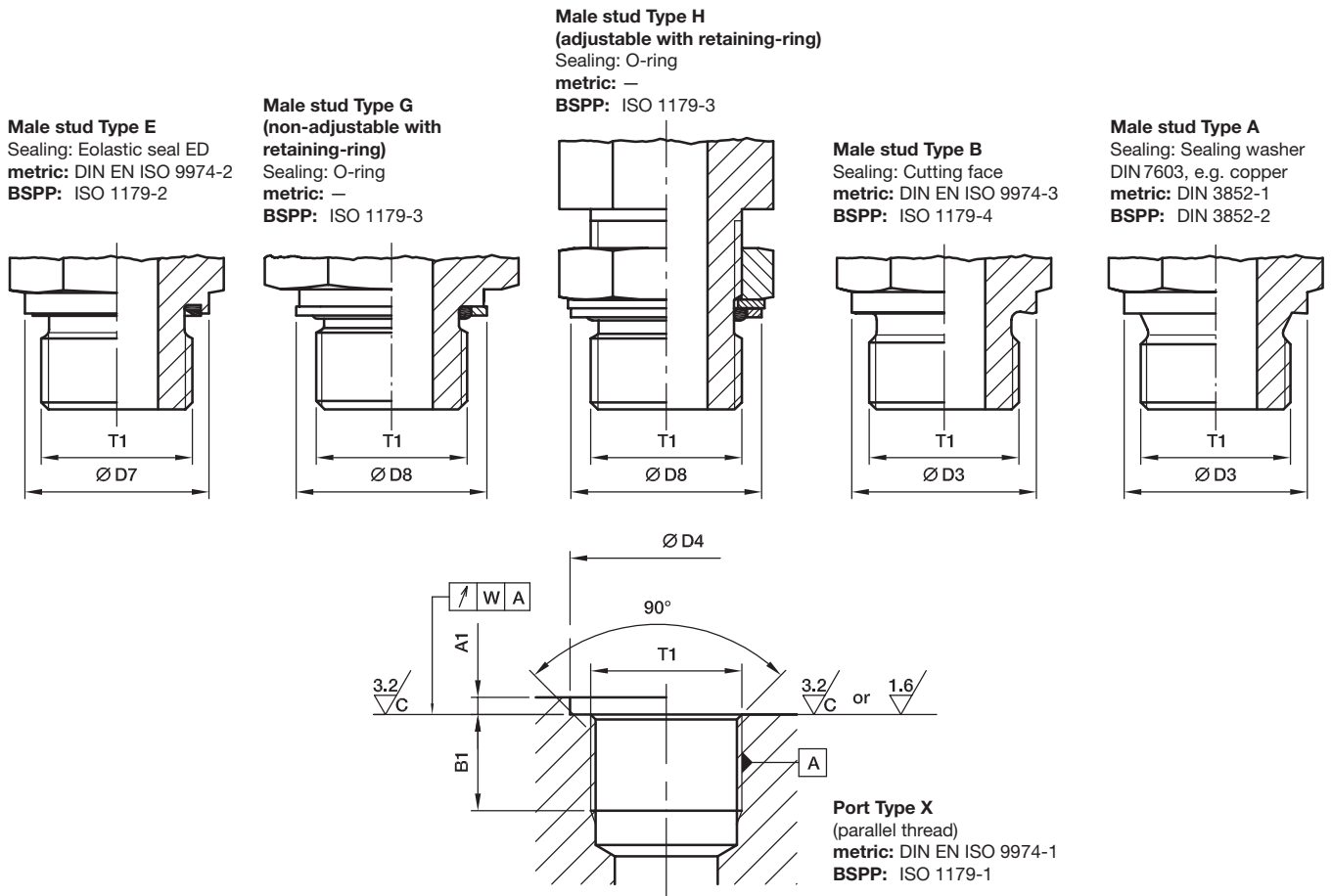

Thread T1	Ø D3 mm	Ø D7 mm	D8		D4 min. small	D4 ^{+0.4} wide*	A1 max.	B1 min.	W	Identification internal	
			small	wide						Thread major diameter	Thread minor diameter
M 08×1.0			12.8	13.15					0.1	8.00	6.92
M 10×1.0	13.9	13.9	14.8	14.75	15	20	1.0	8	0.1	10.00	8.92
M 12×1.5	16.9	16.9	17.8	17.75	18	25	1.5	12	0.1	12.00	10.38
M 14×1.5	18.9	18.9	19.8	19.75	20	25	1.5	12	0.1	14.00	12.38
M 16×1.5	20.9	21.9	22.8	21.75	23	28	1.5	12	0.1	16.00	14.38
M 18×1.5	22.9	23.9	24.8	23.75	25	30	2.0	12	0.1	18.00	16.38
M 20×1.5	24.9	25.9	26.8	25.75	27	34	2.0	14	0.1	20.00	18.38
M 22×1.5	26.9	26.9	27.8	27.75	28	34	2.5	14	0.1	22.00	20.38
M 26×1.5	30.9	31.9	32.8	31.75	33	42	2.5	16	0.2	26.00	24.38
M 27×2.0	31.9	31.9	32.8	32.75	33	42	2.5	16	0.2	27.00	24.84
M 33×2.0	38.9	39.9	40.8	39.75	41	47	2.5	18	0.2	33.00	30.84
M 42×2.0	48.9	49.9	50.8	49.75	51	58	2.5	20	0.2	42.00	39.84
M 48×2.0	54.9	54.9	55.8	54.95	56	65	2.5	22	0.2	48.00	45.84
G 1/8 A	13.8	13.9	14.8	15.00	15	19	1.0	8	0.1	9.73	8.57
G 1/4 A	17.8	18.9	19.8	19.50	20	25	1.5	12	0.1	13.16	11.45
G 3/8 A	21.8	21.9	22.8	23.50	23	28	2.0	12	0.1	16.66	14.95
G 1/2 A	25.8	26.9	27.8	28.50	28	34	2.5	14	0.1	20.96	18.63
G 3/4 A	31.8	31.9	32.8	34.50	33	42	2.5	16	0.2	26.44	24.12
G 1 A	38.8	39.9	40.8	43.50	41	47	2.5	18	0.2	33.25	30.29
G 1 1/4 A	48.8	49.9	50.8	52.50	51	58	2.5	20	0.2	41.91	38.95
G 1 1/2 A	54.8	54.9	55.8	60.00	56	65	2.5	22	0.2	47.80	44.85

*For inch threads: Enlarged diameter vs. ISO 1179-1 to adopt multiple seal ring designs.

Port end dimensions for tube fittings

Male stud NPT/F
Sealing: Tapered thread¹⁾
NPT ANSI/ASME B 1.20.1-1983
NPTF ANSI/ASME B 1.20.3-1976

Male stud BSPT
Sealing: Tapered thread¹⁾
ISO 7/BS 21/DIN 2999-1

Male stud Type C
Sealing: Tapered thread short¹⁾
metric DIN 3852-1
BSPT DIN 3852-2

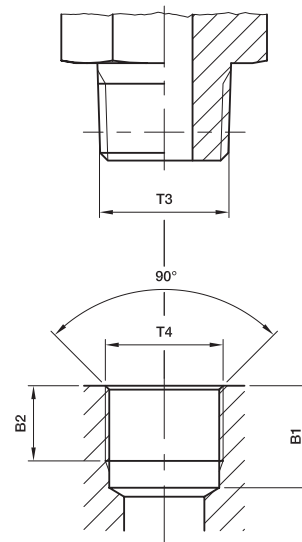
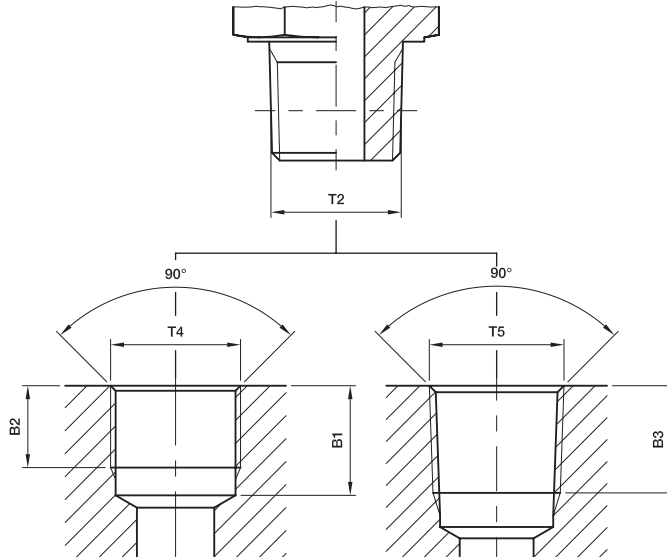
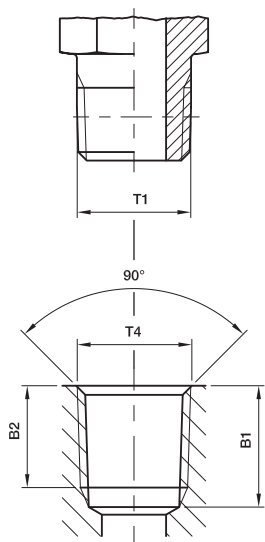

Port NPT/F (taper)
NPT ANSI/ASME B 1.20.1-1983
NPTF ANSI/ASME B 1.20.3-1976

Port BSPP (parallel)
ISO 7/1-Rp
BS 21-Rp (ISO 1179-1)

Port BSPT (taper)
ISO 7/1-Rc/BS 21-Rc
DIN 2999-Rc (Japan: PT)

Port (parallel)
metric DIN 3852-1
BSPP DIN 3852-2

Thread T1	Thread T2	Thread T3	Thread T4	Thread T5	B1 min.	B2 min.	B3 min.
1/8-27 NPT/F*			1/8-27 NPT/F*		11.6	6.9	
1/4-18 NPT/F*			1/4-18 NPT/F*		16.4	10.0	
3/8-18 NPT/F*			3/8-18 NPT/F*		17.4	10.3	
1/2-14 NPT/F*			1/2-14 NPT/F*		22.6	13.6	
3/4-14 NPT/F*			3/4-14 NPT/F*		23.1	14.1	
1-11.5 NPT/F*			1-11.5 NPT/F*		27.8	16.8	
1 1/4-11.5 NPT/F*			1 1/4-11.5 NPT/F*		28.3	17.3	
1 1/2-11.5 NPT/F*			1 1/2-11.5 NPT/F*		28.3	17.3	
	R 1/8		Rp 1/8	Rc 1/8	9.7	7.9	7.4
	R 1/4		Rp 1/4	Rc 1/4	12.0	11.2	11.0
	R 3/8		Rp 3/8	Rc 3/8	13.5	12.0	11.4
	R 1/2		Rp 1/2	Rc 1/2	17.6	15.0	15.0
	R 3/4		Rp 3/4	Rc 3/4	19.1	16.0	16.3
	R 1		Rp 1	Rc 1	21.4	19.1	19.0
	R 1 1/4		Rp 1 1/4	Rc 1 1/4	21.4	19.9	21.4
	R 1 1/2		Rp 1 1/2	Rc 1 1/2	22.4	20.6	21.4
		M 08×1.0 tap.	M 08×1.0		10.0	5.5	
		M 10×1.0 tap.	M 10×1.0		10.0	5.5	
		M 12×1.5 tap.	M 12×1.5		13.5	8.5	
		M 14×1.5 tap.	M 14×1.5		13.5	8.5	
		M 16×1.5 tap.	M 16×1.5		13.5	8.5	
		M 18×1.5 tap.	M 18×1.5		13.5	8.5	
		M 20×1.5 tap.	M 20×1.5		15.5	10.5	
		M 22×1.5 tap.	M 22×1.5		15.5	10.5	
		R 1/8 tap.	Rp 1/8		8.5	5.5	
		R 1/4 tap.	Rp 1/4		12.5	8.5	
		R 3/8 tap.	Rp 3/8		12.5	8.5	
		R 1/2 tap.	Rp 1/2		16.5	10.5	

*In the EO fitting range only NPT thread is manufactured.

In the Triple-Lok®, O-Lok® and adapters fitting range for steel NPTF thread is manufactured and for stainless steel NPT thread is manufactured.

1) Tightness can only be achieved by liquid or plastic sealing aids.

DM Technology



Tube assembly



Index

Safety instructions E4

General E5

Selection of assembly process..... E6

New EO assembly instructions for 30° final assembly E10

EO Progressive ring PSR/DPR E11

EO-2 assembly instructions..... E16

Checking instructions for EO assembly tools..... E22

EO2-FORM assembly instructions E23

Checking instructions for EO2-FORM tools E29

Weld fitting assembly..... E30

O-Lok® assembly instructions E31

Triple-Lok® assembly instructions E35

Checking instructions for O-Lok® / Triple-Lok® E39

Ferulok® assembly instructions E40



Safety instructions

Tube fittings are safe high-pressure connections

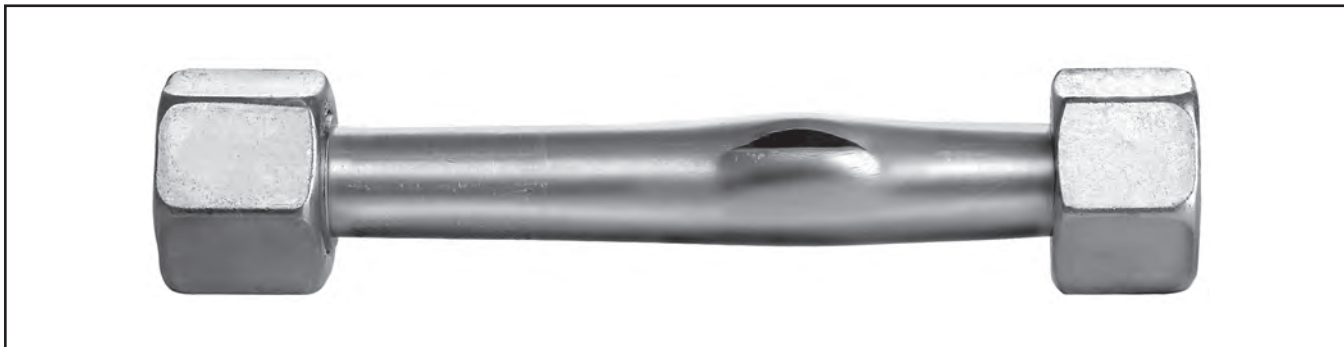

A carefully assembled Parker tube fitting will provide a sealed joint even up to tube burst. Experience has shown that break-downs, re-tightening and leaks can be avoided by following these safety instructions. Please review your fitting procedures.

General safety instructions

- Uncompleted assembly will reduce the pressure and vibration capability of a fitting. It can reduce the life cycle time of a connection and leakage can occur. In extreme cases the connection can fail due to tube shear or tube crack.
- After opening a tube connection, the unit has to be re-tightened with the same force used during prior assembly. Under tightening can result in leakage and can reduce the vibration resistance. Over tightening can reduce the possibilities of repeated assembly. In extreme cases the components can be destroyed.
- Parker tube fittings are intended solely for connections for fluid applications.
- Observe tube recommendations. Non-standard materials or tolerances lead to incorrect assembly.
- Do not use ball bearings, fitting pins or tapered pins, coins or washers instead of the correct Parker blanking plug as blanking parts for 24° cones.
- Tube connection and fitting body once assembled, should remain together. Fitting body is to be used once only for pre-assembly.
- Air bleeding of tube fittings which are under pressure can be dangerous.
- Tube under tension can lead to vibration failure. Tube length and bend angles are to be adhered to precisely. Fix tube lines with tube clamps.
- Tubes are not to be clamped to one another but to suitable fixed points. Plate brackets, cable connections and fixing elements are not suitable. Tubes are not mountings on which to integrate other components e.g. filters, ventilators or shut-off valves.
- Prevent oscillation, pressure surges and inherent strain by using flexible hoses for example.
- Under and over tightening of fittings during assembly reduces the capacity for withstanding pressure and vibration loads and therefore reduces the life of the tube fitting. Leaks from the tube can occur under these circumstances.
- When dismantling/transporting and re-assembling, make sure that no dirt enters the system, that the connection elements (threads, sealing surfaces) are not damaged, seals are not lost and tubes are not bent or flattened. We recommend the use of suitable protective caps.
- Disassembled fittings are to be checked for accuracy and damage and replaced if necessary.
- Do not use hand cutters or tube cutters.

- Dirt and metal contamination can lead to damage to the system and leaks.
- The operating parameters given (e.g. pressure, temperature, medium compatibility) are to be adhered to.
- Avoid flow rates > 8 m/s. The resulting forces are high and can destroy the tube lines.
- Relevant guidelines (e.g. CE, ISO, BG, TÜV, DIN) are to be observed.
- Weld fittings are manufactured out of weldable materials. No other fittings are suitable for welding.
- EO-NIROMONT and Parflange LUBSS are high-performance lubricants. The use of other lubricants generally leads to an increase in assembly force.
- The tools and lubricants recommended by Parker guarantee safe assembly.
- Components and tooling of different manufacturers are not necessarily compatible. For complete safety, use only Parker components.
- Fittings are to be handled with care.
- Tube lines need to be adapted tension free of the relevant connectors before assembly. An easy turning of the nut is required for the complete thread length. Otherwise leakage can occur. In extreme cases with additional vibrations tube cracks can occur.
- Vibrations have to be clamped by tube clamps. Independent vibrating units need to be separated with hoses. Otherwise tube cracks can occur.

Specific safety instructions for assembly

- During a progressive ring and EO-2 fitting assembly the tube has to bottom up in the stud or in the tool. Without tube bottoming the ring cannot bite sufficiently. Under load the connection can fail due to tube shear.
- Correctly flared tubes are essential for leak free performance of Triple-Lok® fittings. Special care must be taken over the flare diameter and surface finish.
- Preset bite type fittings (Progressive ring) need a final assembly according to assembly instructions.
- Stainless steel progressive ring fittings have to be preassembled in hardened tools. Otherwise the connection may fail under load due to tube shear.
- Do not assemble progressive rings and functional nuts on self-made standpipe stud ends. There is a risk of false assembly with the result of connection shear under load.
- The use of steel cutting rings for stainless steel tubes or other unauthorised tool combinations leads to incorrect assembly.

In case of doubt please contact your Parker representative!

General

Assembly of Parker tube fittings always follows the same pattern:

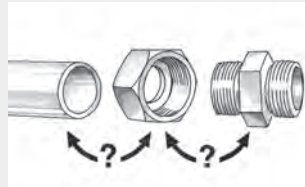

Material combinations

- Use recommended tube material
- Select suitable components according to tube material



Tube preparation

- Cut and deburr thoroughly
- Follow recommendations for minimum straight tube length
- Apply support sleeves when necessary



Machine assembly

- Preferred method
- Most efficient method
- Recommended for large EO progressive ring and EO-2
- Parflange® recommended for 37° flaring

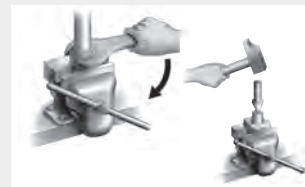

Manual assembly

- Economical for assembly of small quantities
- Suitable for small O.D. tube
- For repair work
- Hand flaring does not provide reliable results
- Stainless steel progressive ring fittings need to be assembled with pre-assembly tools



Assembly check

- Check assembly tube preparation result
- ⚠ Incorrect assemblies must be corrected or scrapped

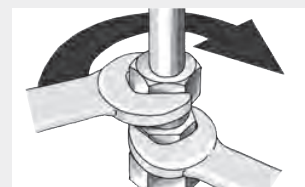



















Final installation

- Final fitting assembly according to instruction
- Do not assemble under tension
- Clamp onto rigid fixtures
- Tighten tube clamps after final fitting installation









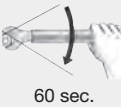

E

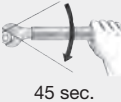
Selection of assembly process for bite systems

Workshop machines for industrial assembly					
Process			Product		
Procedure	Equipment	Process/Time*	Economic production qty.	EO progressive ring PSR/DPR	EO-2
Pre-assembly using EOMAT ECO machine		 30 sec.	max. 50 assemblies per day	hydraulic service and on-site installation	ideal for workshop assembly, not ideal for serial production
Pre-assembly using EOMAT UNI machine		 15 sec.	max. 100 assemblies per day	ideal for workshop assembly, not suitable for LL series	ideal for workshop assembly, not suitable for LL series
Pre-assembly using EOMAT PRO machine		 8-12 sec.	min. 100 assemblies per day	ideal for workshop assembly and mass production	ideal for workshop assembly and mass production
Tube forming using EO-KARRYFORM machine		 20 sec.	max. 100 assemblies per day	not applicable	not applicable
Tube forming using EO2-FORM F3 machine		 20 sec.	max. 300 assemblies per day	not applicable	not applicable
Tube forming using EO2-FORM PRO22 machine		 6 sec.	min. 100 assemblies per day	not applicable	not applicable
Tube flaring using Parflare ECO		 30 sec.	max. 50 assemblies per day	not applicable	not applicable
Tube flaring using Parflange® 1025 machine		 45 sec.	max. 100 assemblies per day	not applicable	not applicable
Tube flaring using Parflange® 50 machine		 30 sec.	Basic: max. 500 assemblies per day PRO: 1200 assemblies per day	not applicable	not applicable

*Average for total assembly time of medium size fitting including assembly check and final tightening

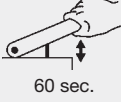
Selection of assembly process for bite systems

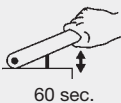

















Manual assembly for field repair					
Procedure	Process		Economic production qty.	Product	
	Equipment	Process/Time*		EO progressive ring PSR/DPR	EO-2
Direct in fitting		 60 sec.	max. 10 assemblies per week	field repair only, not for efficient production and tubes larger than 22 mm OD, preferred method for PSR, not for stainless steel	field repair only, not for efficient production and tubes larger than 22 mm OD
Pre-assembly in vice		 45 sec.	max. 10 assemblies per week	field repair only, not for efficient production	field repair only, not for efficient production
Flaring in vice		 120 sec.	max. 10 flarings per week	not applicable	not applicable
Pre-assembly using HVM-B device		 30 sec.	max. 50 assemblies per day	final assembly in fitting must be 1/2 turn, not for tubes larger than 15 mm OD, not for stainless steel	not applicable
Pre-assembly using EO-KARRYMAT		 60 sec.	max. 20 assemblies per day	ideal for repair jobs and small on-site installations, not suitable for volume production	ideal for repair jobs and small on-site installations, not suitable for volume production
Tube flaring using KARRYFLARE		 60 sec.	max. 20 flarings per day	not applicable	not applicable

*Average for total assembly time of medium size fitting including assembly check and final tightening

E

Tube assembly

Selection of assembly process for tube forming systems

Workshop machines for industrial assembly					
Process			Product		
Procedure	Equipment	Process/Time*	EO2-FORM	Triple-Lok®	O-Lok®
Pre-assembly using EOMAT ECO machine		 30 sec.	not applicable	not applicable	not applicable
Pre-assembly using EOMAT UNI machine		 30 sec.	not applicable	suitable for workshop assembly, preferred process is Parflange®	not applicable
Pre-assembly using EOMAT PRO machine		 10 sec.	not applicable	not applicable	not applicable
Tube forming using EO-KARRYFORM machine		 20 sec.	ideal for repair jobs and small on-site installations, not recommended for mass production	not applicable	not applicable
Tube forming using EO2-FORM F3 machine		 40 sec.	ideal for workshop assembly and serial production	not applicable	not applicable
Tube forming with EO2-FORM PRO22 machine		 6 sec.	ideal for workshop assembly and serial production	not applicable	not applicable
Tube flaring using Parflare ECO machine		 30 sec.	not applicable	ideal for on-site installations, not recommended for mass production	not applicable
Tube flaring using Parflange® 1025 machine		 45 sec.	not applicable	ideal for workshop assembly, not recommended for mass production, not suitable for assembly of SS tubes over 25 mm	ideal for workshop assembly, not recommended for mass production, not suitable for assembly of SS tubes over 25 mm
Tube flaring using Parflange® 50 machine		 30 sec.	not applicable	ideal for workshop assembly and serial production	ideal for workshop assembly and serial production automatic sleeve feeder available for mass production

*Average for total assembly time of medium size fitting including assembly check and final tightening

Selection of assembly process for tube forming systems

Manual assembly for field repair					
Process			Product		
Procedure	Equipment	Process/Time*	EO2-FORM	Triple-Lok®	O-Lok®
Direct in fitting		 60 sec.	not possible, use EO-2 for field repair	not possible, use 1015 device or hand flaring tools for field repair	not possible, use braze sleeves or hose lines for field repair
Pre-assembly in vice		 45 sec.	not possible, use EO-2 for field repair	not possible, use 1015 device or hand flaring tools for field repair	not possible, use braze sleeves or hose lines for field repair
Flaring in vice		 120 sec.	not applicable	field repair only, not for efficient production, not for stainless steel tubes	not possible, use braze sleeves or hose lines for field repair
Pre-assembly using HVM-B device		 30 sec.	not applicable	not applicable	not applicable
Pre-assembly using EO-KARRYMAT		 60 sec.	not possible, use EO-2 for field repair	not applicable	not applicable
Tube flaring using KARRYFLARE		 60 sec.	not possible, use EO-2 for field repair	ideal for repair jobs and small on-site installations, not suitable for industrial production	not applicable

*Average for total assembly time of medium size fitting including assembly check and final tightening

New EO assembly instructions for 30° final assembly

Traditional pre-assembly

- According to DIN 3859 T2
- Can be used optional as usual
- Machine preset
- Manual preset

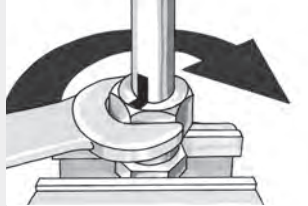

- Machine presetting: Machine preset corresponding to 1/4 turn of nut

- Manual presetting: Tighten the nut by 1/4 turns

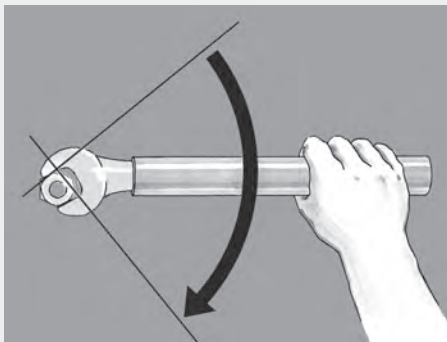

Final assembly
Before 90°
 1/4 turn
 after perceptible rise in force

Optimized EO pre-assembly

- Machine preset
- Manual preset

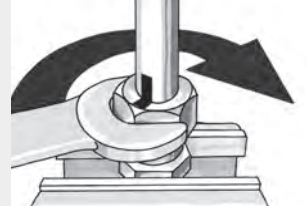

- Machine presetting: Machine preset corresponding to 1/2 turn of nut

- Manual presetting: Tighten the nut by 1/2 turns

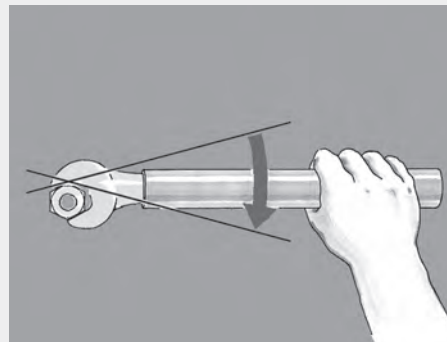

Final assembly
Now 30°
 1/12 turn
 after perceptible rise in force

EO progressive ring PSR/DPR

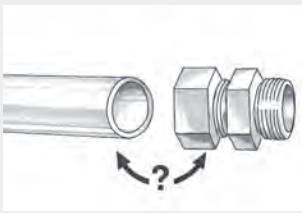

Material combinations

- Select suitable EO progressive ring fitting

Tube material	EO-Fitting body	assembly instructions
Steel	Steel (LL=D-Ring)	
Stainless Steel	Stainless Steel	Pre-assembly by machine or hardened tool required
Copper	Brass (D-Ring)	
Plastic e.g. Polyamide	Steel, Brass, Stainless Steel	Support sleeve E required Check assembly devices for suitability
Stainless Steel	Steel	Stainless Steel DPR must be used Pre-assembly by machine or hardened tool required



Tube preparation

- Cut and deburr thoroughly
- Do not assemble under tension

		Min. length straight tube ends									
		Series L									
Tube OD		06	08	10	12	15	18	22	28	35	42
L min		39	39	42	42	45	49	53	53	60	60
		Series S									
Tube OD		06	08	10	12	14	16	20	25	30	38
L min		44	44	47	47	54	54	59	68	73	82

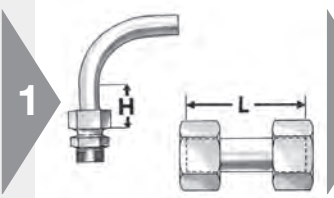

- Minimum lengths of straight tube-ends, $H=2 \times$ nut length
- Use swivel union "GZ" instead of short tubes

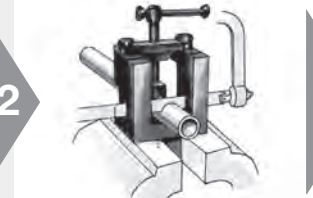

- Cut tube squarely
- max $\pm 1^\circ$ deviation
- ⚠ Do not use pipe cutters
- EO tube-cutting tool (AV) for manual cutting



- Remove internal and external burrs
- max. chamfer $0.3 \text{ mm} \times 45^\circ$
- Recommendation: In-Ex Tube Deburring Tool 226



Support sleeves VH

- Support sleeve VH for thin wall or soft metal tubes (see chart)

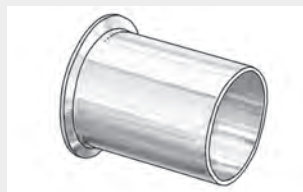

Tube insert E

- Support sleeve E for plastic tubes

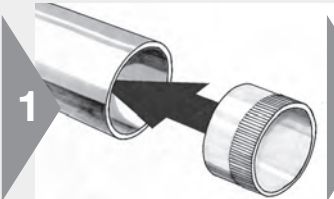

- Insert support sleeve like shown

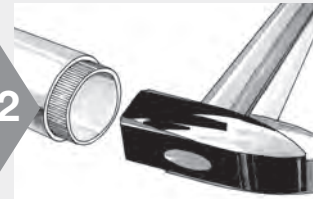

- Drive VH into tube-end

- Support sleeve required
- Support sleeve required for heavily loaded lines (vibrations)

VH selection chart for EO Progressive Ring
For steel tubes material ST 37.4
and for stainless steel tubes material 1.4571 and 1.4541

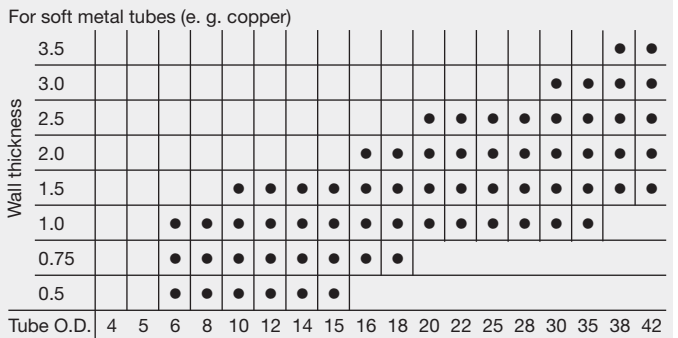
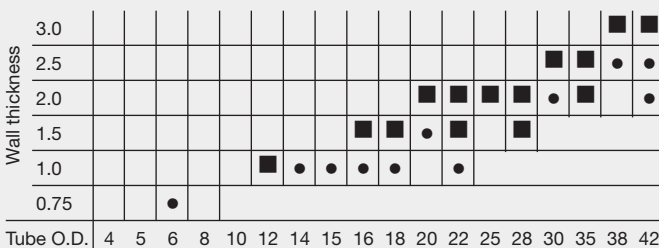

Tube assembly

EO progressive ring PSR/DPR



EOMAT PRO



EOMAT UNI



EO-KARRYMAT

100% Pre-assembly with EOMAT/EO-KARRYMAT

- Preferred method
- Most efficient method
- ⚠ HVMB-device not suitable for 100% assembly of PSR fittings

1

Automatik

12-L PSR/DPR

Counter	123
Lifetime MOK	123456

2



Ok?

3

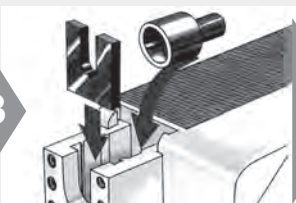

4

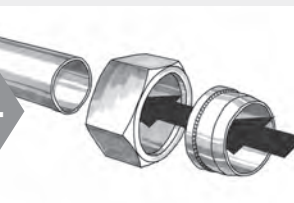

- EOMAT ECO/UNI and EO-KARRYMAT: Adjustment according to pressure chart on machine (PSR/DPR) Reduction of preset pressures for tube materials softer than steel and stainless steel required
- EOMAT PRO: Automatic tool recognition
- Non-EOMAT-machines: Check suitability

⚠ Use genuine Parker assembly cone "MOK"

- Control (see checking instructions)
- Clean and lubricate assembly cone and thread regularly
- For EOMAT PRO use assembly cone "MOK...PRO" with transponder chip

- Insert proper tools
- Clean and lubricate assembly cones regularly
- EO-KARRYMAT: Close valve on handpump
- 2-piece backing plates for 35-L and 42-L

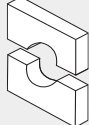

- Slide nut and progressive ring as shown onto the end of the tube

5

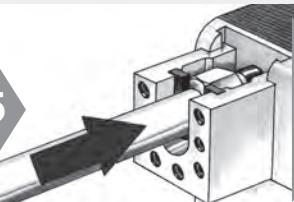

6



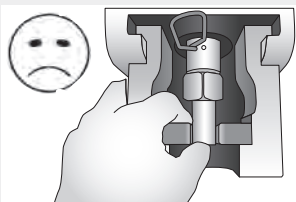

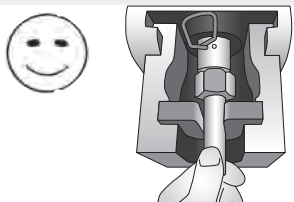

- Place tube with progressive ring and nut into the die
- Press tube-end firmly into the assembly cone



- Hold tube firmly
- EOMAT: Press and hold start button
- Use support and foot switch for long tubes
- EO-KARRYMAT: Operate handpump until assembly pressure is reached

- Safe holding of to be processed tubes
- While holding and setting down, do not hold onto the lifting zone of the cylinder

7

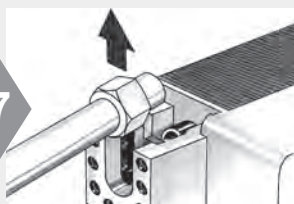

8

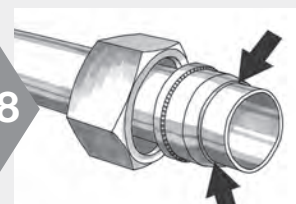

9



10

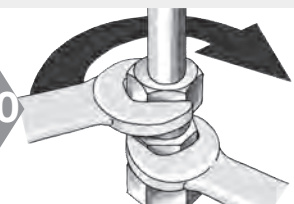

- After completion of pre-assembly, remove the tube for assembly check
- EO-KARRYMAT: Open valve on handpump

⚠ Check to make sure that a visible collar covers the front of the first cutting edge

- It does not matter if the ring can be rotated on the tube-end

- Use distance gauge AKL for checking in mass production

- Assemble fitting until wrench-tight (without spanner extension) Mark position of nut
- ⚠ The body must be held rigid

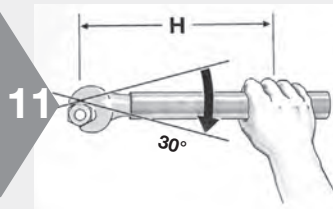

- 11
- ⚠ Then tighten fitting firmly by 30° (½ flat)
 - ⚠ Recommended to use spanner extension for sizes over 20 mm O.D. (**see chart**)
 - Assembly torques are available on request

Spanner length

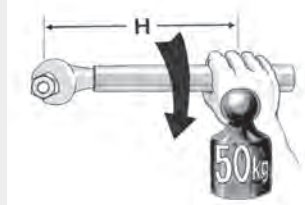

Size	Spanner length H [mm]
22-L	400
28-L 20-S	500
35-L 25-S	800
42-L 30-S	1000
38-S	1200

EO progressive ring PSR/DPR

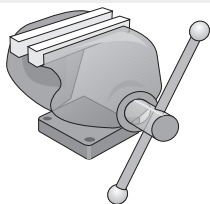

Pre-assembly with hardened tool VOMO

- Reliable method for repair jobs
- Only economic for assembly of small quantities
- ⚠ Stainless steel EO progressive rings must be pre-assembled using a hardened tool (VOMO)
- For tubes over 25 mm, EO-KARRYMAT/EOMAT is recommended



- ⚠ For stainless steel assembly threads must be lubricated
- Use EO-NIROMONT special high-performance lubricant for stainless steel fittings



- Control (see checking instructions)
- Cones of pre-assembly bodies must be checked regularly (after 50 pre-assemblies) with cone templates (KONU)
- Clean and lubricate assembly cone and thread regularly



- Use pre-assembly tool VOMO
- Fitting body may be used one time only (not for stainless steel)
- Screw on nut until finger-tight

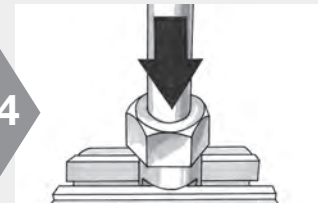

- ⚠ Press tube-end firmly into the assembly cone

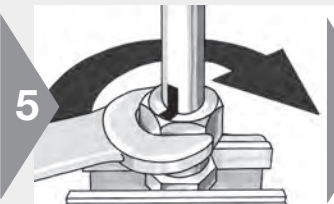
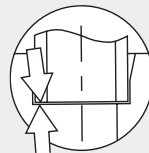

- ⚠ Mark position of the nut
- Tighten the nut by 1½ turns
- ⚠ Recommended to use spanner extension for sizes over 20 mm O.D.

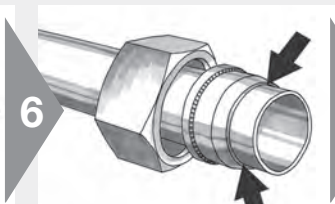

- Assembly check:**
- Loosen nut
- ⚠ Check to make sure that a visible collar covers the front of the first cutting edge
- ⚠ It does not matter if the ring can be rotated on the tube-end

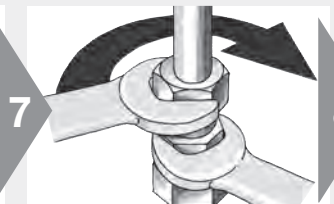

- Assemble fitting until wrench-tight (without spanner extension)
- ⚠ Mark position of nut
- ⚠ The body must be held rigid

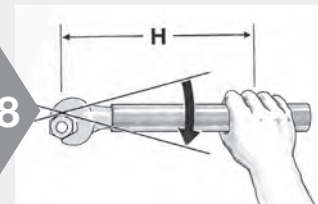

- ⚠ Then tighten fitting firmly by 30° (½ flat)
- ⚠ Recommended to use spanner extension for sizes over 20 mm O.D. (see chart)
- Assembly torques are available on request

Spanner length

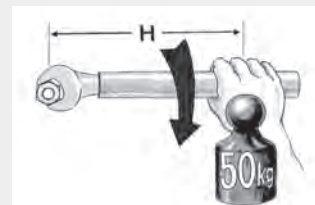

Size	Spanner length H [mm]
22-L	400
28-L 20-S	500
35-L 25-S	800
42-L 30-S	1000
38-S	1200

EO progressive ring PSR/DPR

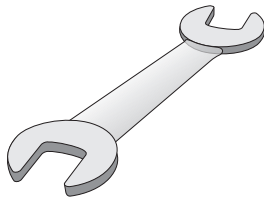

Direct assembly

- Simple procedure for single assemblies of small dimensions
- Not economic for series assembly
- ⚠ Tubes \varnothing 30, 35, 38 and 42 mm must be pre-assembled in vice
- ⚠ Stainless steel connections have to be assembled using pre-assembly tool (VOMO)
- ⚠ Properly cleaned studs ("BE") have to be assembled with pre-assembly tools

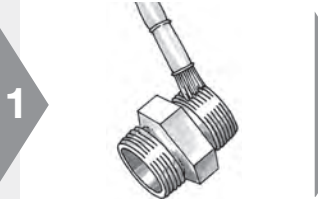

- ⚠ Lubrication of threads will reduce wear and assembly forces
- ⚠ Threads on stainless steel fittings must be lubricated
- ⚠ Use EO-NIROMONT special high-performance lubricant for stainless steel fittings

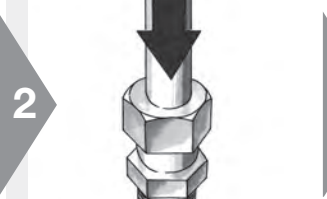

- Screw on nut until finger-tight
- ⚠ Press tube-end firmly into fitting body

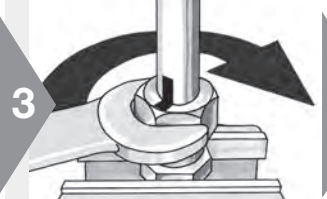

- Mark position of the nut
- Tighten the nut by 1½ turns
- ⚠ Recommended to use spanner extension for sizes over 20 mm O.D. (see chart)
- Fitting body may be used one time only

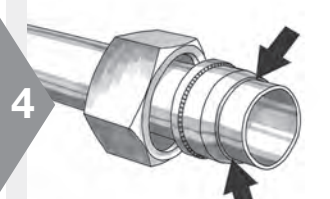

- Assembly check:**
- Loosen nut
 - ⚠ Check to make sure that a visible collar covers the front of the first cutting edge
 - It does not matter if the ring can be rotated on the tube-end

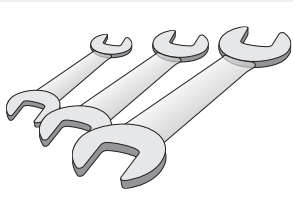

Repeated assembly

- Each time the tube-end has been disconnected, the fitting must be properly tightened again
- ⚠ EO progressive rings cannot be replaced, once assembled



- ⚠ Threads on stainless steel fittings must be lubricated
- ⚠ Use EO-NIROMONT special high-performance lubricant for stainless steel fittings

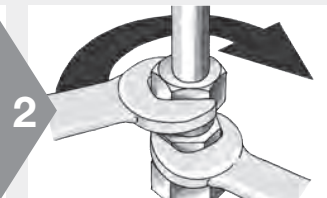

- When repeating the assembly the nut must be tightened with a wrench in the primary original position.
- The body must be held rigid
- ⚠ Recommended to use spanner extension for sizes over 20 mm O.D. (see chart)

Spanner length

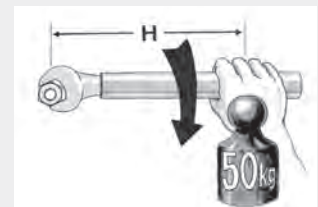

Size	Spanner length H [mm]
22-L	400
28-L 20-S	500
35-L 25-S	800
42-L 30-S	1000
38-S	1200

EO-2 assembly instructions

Tube preparation



- Cut and deburr thoroughly
- Do not assemble under tension

1

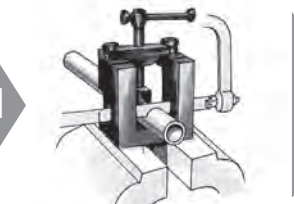

- Cut tube squarely
- max ± 1° deviation
- ⚠ Do not use pipe cutters
- EO tube-cutting tool (AV)

2

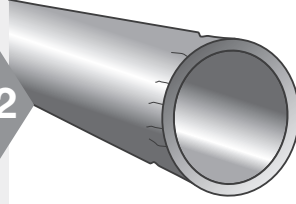

- Don't deform tube end at cutting or bending
- Marks or scratches can result in leakage
- Thin wall and soft tubes are very sensitive

3



- Remove internal and external burrs
- max. chamfer 0.3 mm × 45°
- Seal can be damaged by large burrs

Material combinations

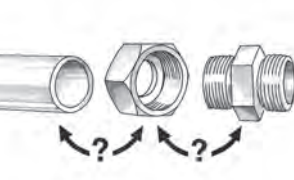

- Select suitable FM-type

	Steel tube	Stainless Steel tube	Plastic tube
Steel fitting	FM...CF	FM...SSA	FM...CF+E
Stainless Steel fitting	—	FM...71	FM...71+E

Tube insert E



- Tube insert E for plastic tubes

Support sleeves VH



- Support sleeve VH for thin wall or soft metal tubes

1

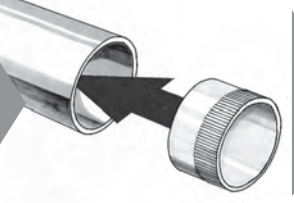

- Support-sleeve selection: see instruction shipped with product

2

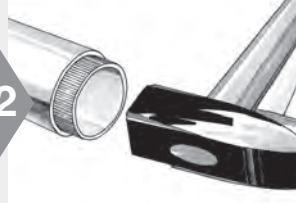

- Drive VH into tube-end

Use of support sleeves "VH" with EO-2 fittings

Tube O.D.	0.5	0.75	1	1.5	2	2.5	3	3.5	4
4									
6									
8									
10									
12									
14									
15									
16									
18									
20									
22									
25									
28									
30									
35									
38									
42									

Functional test required for other materials or dimensions not specified. Support sleeve VH not required for EO-2 steel (FM/CF) and steel tube. For EO-2 stainless steel (FM/71) and stainless steel tube, a functional test is required. Support sleeve VH **not required** for EO-2 and steel tube. Support sleeve VH **not required** for EO-2/71 or EO-2/SSA and stainless steel tube.

EO-2 assembly instructions



Replacement of sealing ring/Repeated assembly

- Sealing ring DOZ can be changed separately

Spanner length

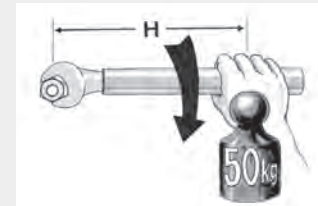

Size	Spanner length H [mm]
22-L	400
28-L 20-S	500
35-L 25-S	800
42-L 30-S	1000
38-S	1200

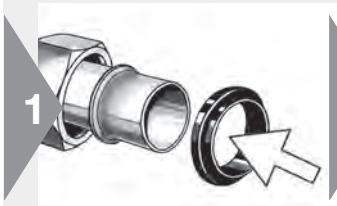

- 1
- After disassembly, sealing ring can be pulled of the tube-end
 - Check for damage and replace if necessary
 - Abrasion on outer rubber parts does not effect performance

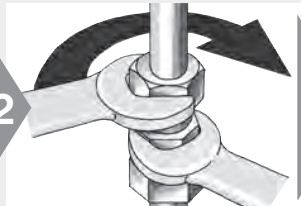

- 2
- Assemble fitting until wrench-tight (without spanner extension)



The body must be held rigid

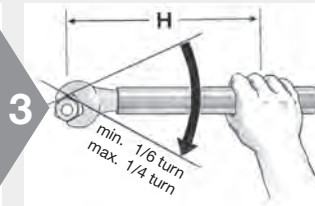

- 3
- ⚠ Then tighten fitting firmly by min $\frac{1}{6}$ (max $\frac{1}{4}$) turn (1 to $1\frac{1}{2}$ flats)
 - ⚠ Recommended to use spanner extension for sizes over 20 mm O.D. (see chart)

EO-2 assembly instructions



EOMAT PRO



EOMAT UNI



EO-KARRYMAT

Assembly with EOMAT/EO-KARRYMAT

- Preferred method
- Most efficient method
- HVM-B device is not suitable for EO-2

1 **Automatik**
12-L EO-2
Counter 123 

2



Ok?

3

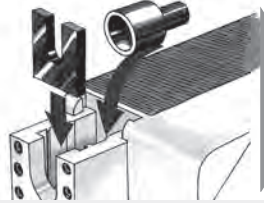

4

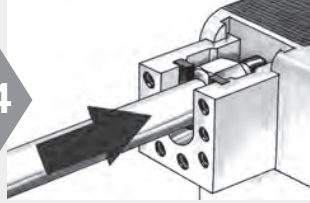

- EOMAT ECO/UNI: Adjustment according to pressure on machine (see instructions shipped with product box)
- EOMAT PRO: Automatic tool recognition
- EO-KARRYMAT: Refer to chart on machine
- Non-EOMAT-machines: check suitability

⚠ Use genuine Parker assembly cone "MOKEO2"

- Check according to MOK checking instructions
- For EOMAT PRO use assembly cone "MOK...PRO" with transponder chip. Advantages: easy and safe assembly

- Insert proper tools
- 2-piece tube backing plates for 35-L and 42-L
- EO-KARRYMAT: Close valve on handpump

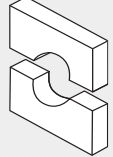

- Place tube with functional nut into the die
- Press tube-end firmly into the assembly cone
- Hold back nut for easy tube insertion



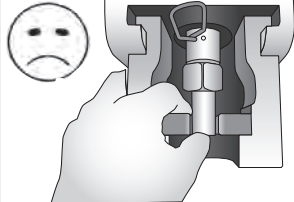
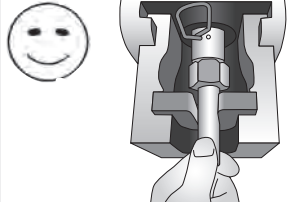



- Safe holding of to be processed tubes
- While holding and setting down, do not hold onto the lifting zone of the cylinder

5

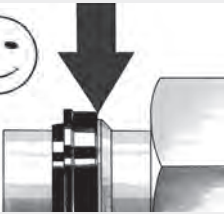

6



7

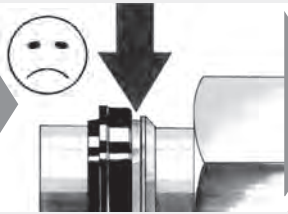

8

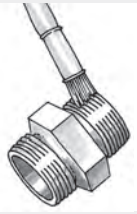

- Hold tube firmly
- EOMAT: Press and hold start button
- Use support and foot switch for long tubes
- EO-KARRYMAT: Operate handpump until assembly pressure is reached. Then open valve on handpump

Assembly check:

- Gap between sealing ring and retaining ring must be closed
- A little relaxation (approx. 0.2 mm) is allowed

Gap not closed:

- ⚠ Check all components, tube, machine, tools and pressure setting
- ⚠ Repeat assembly with increased pressure if necessary

- ⚠ Threads of stainless steel fittings must be lubricated
- ⚠ Use EO-NIROMONT special high-performance lubricant for stainless steel fittings

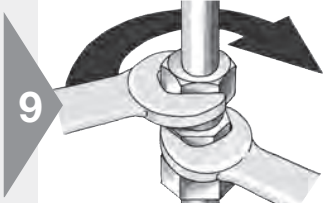

9

- Assemble fitting until wrench-tight (without spanner extension)
- ⚠ The body must be held rigid

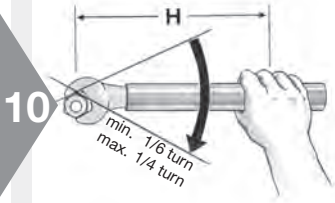

10

min. 1/6 turn
max. 1/4 turn

- ⚠ Then tighten fitting firmly by min 1/6 (max. 1/4) turn (1 to 1 1/2 flats)
- ⚠ Recommended to use spanner extension for sizes over 20 mm O.D. (see chart)

Spanner length

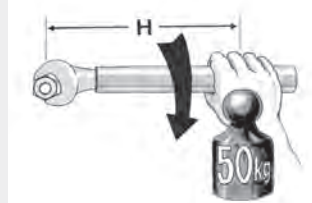

Size	Spanner length H [mm]
22-L	400
28-L 20-S	500
35-L 25-S	800
42-L 30-S	1000
38-S	1200

EO-2 assembly instructions

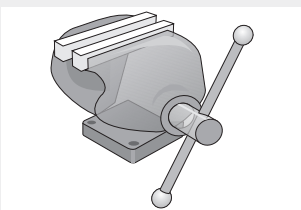

Assembly in vice

- Reliable method
- Only economic for assembly of small quantities

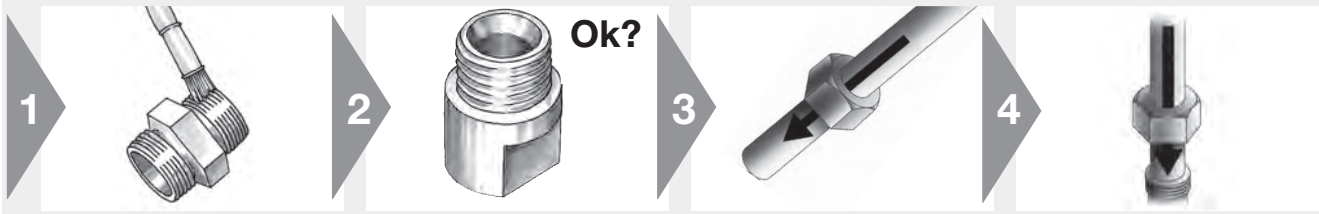

- 1
- ⚠ Threads on stainless steel fittings must be lubricated
 - ⚠ Use EO-NIROMONT special high-performance lubricant for stainless steel fittings

- 2
- Ok?
- Check according to VOMO (checking instructions)
 - Use pre-assembly tool VOMO
 - Fitting body may be used one time only and components must stay together

- 3
- Push functional nut onto tube-end
 - Advantage: Easy tube insertion, particularly large dimensions

- 4
- ⚠ Press tube-end firmly into the assembly cone
 - Screw on nut until finger-tight

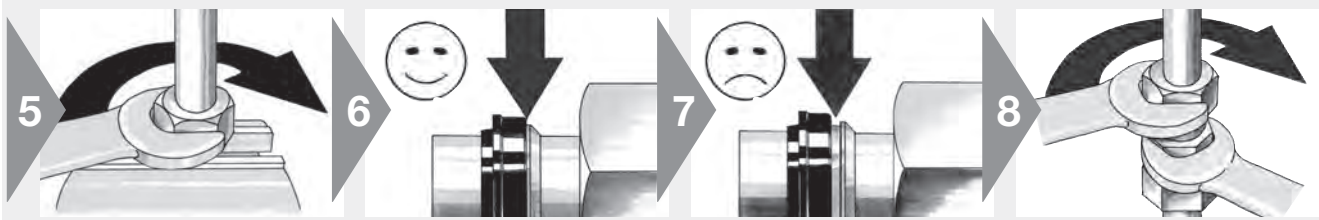
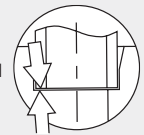

- 5
- Tighten until sharp increase of resistance (approx. 1 to 1½ turns)
 - ⚠ Recommended to use spanner extension for sizes over 20 mm O.D. (see chart)

- 6
- Assembly check:
- Gap between sealing ring and retaining ring must be closed
 - A little relaxation (approx. 0.2 mm) is allowed

- 7
- ⚠ **Gap not closed:** Repeat assembly with increased torque. Check gap again.

- 8
- Assemble fitting until wrench-tight (without spanner extension)
 - ⚠ The body must be held rigid

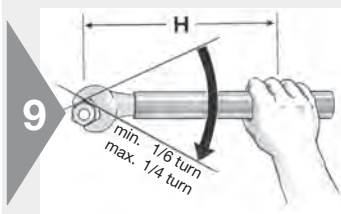

- 9
- ⚠ Then tighten fitting firmly by min 1/6 (max. 1/4) turn (1 to 1½ flats)
 - ⚠ Recommended to use spanner extension for sizes over 20 mm O.D. (see chart)

Spanner length

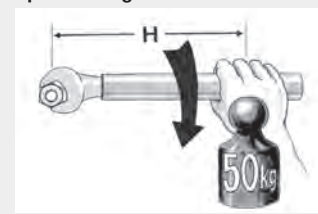

Size	Spanner length H [mm]
22-L	400
28-L 20-S	500
35-L 25-S	800
42-L 30-S	1000
38-S	1200

EO-2 assembly instructions

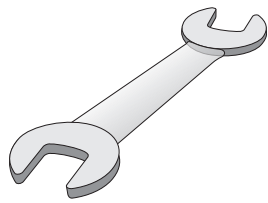

Direct assembly

- Simple procedure for single assemblies of small dimensions
- Not economic for series assemblies
- ⚠ Tubes \varnothing 30, 35, 38 and 42 mm must be pre-assembled in vice

1

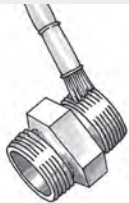

- ⚠ Threads on stainless steel fittings must be lubricated
- ⚠ EO-NIROMONT is a special high-performance lubricant for stainless steel fittings

2



- ⚠ Press tube-end firmly into the assembly cone
- Push back nut for easy tube insertion



3



- Tighten until sharp increase of resistance (approx. 1 to 1½ turns)
- ⚠ Recommended to use spanner extension for sizes over 20 mm O.D. (see chart)

4

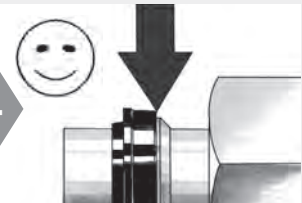

- Assembly check:**
- Gap between sealing ring and retaining ring must be closed
 - A little relaxation (approx. 0.2 mm) is allowed

5



- ⚠ **Gap not closed:** Check all components including tube

6

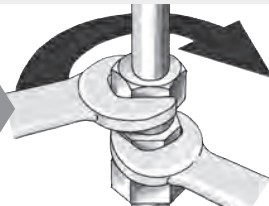

- Assemble fitting until wrench-tight (without spanner extension)
- ⚠ The body must be held rigid

7

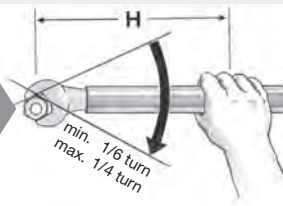

- ⚠ Then tighten fitting firmly by min 1/6 (max 1/4) turn (1 to 1½ flats)
- ⚠ Recommended to use spanner extension for sizes over 20 mm O.D. (see chart)

Spanner length

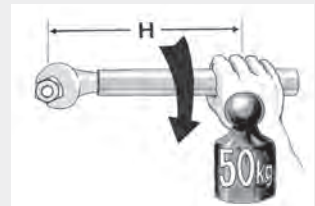

Size	Spanner length H [mm]
22-L	400
28-L 20-S	500
35-L 25-S	800
42-L 30-S	1000
38-S	1200

Checking instructions for EO assembly tools

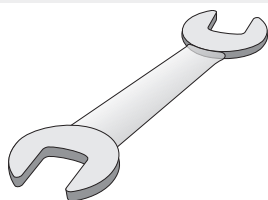

VOMO tools for manual pre-assembly in vice MOK for use in EO assembly machines

- ⚠ Use of damaged, worn or non-suitable tooling may result in fitting failure or machine damage
- ⚠ Tools must be checked regularly, at least after 50 assemblies
- ⚠ Worn tools must be replaced ⚠ Use only genuine Parker tools
- ⚠ Tools must be kept clean and lubricated

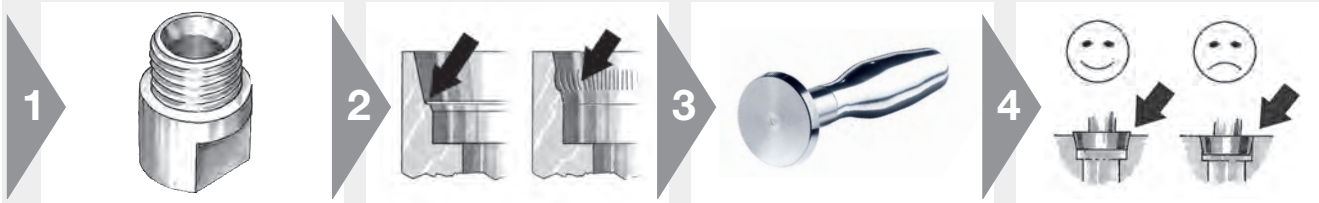

- Clean cone surface for checking
- Visual checks: Cone must be free of wear, damage or cracks
- Check for deformation of geometry
⚠ Special cone template KONU must be used
- KONU cone templates are precision measuring devices and must be handled accordingly
- Check contour: The rear of the template must protrude slightly above the top face of the cone or may be flush

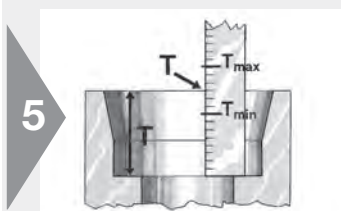

- Check insertion depth
- ⚠ Deviations from the insertion depth can cause leakages

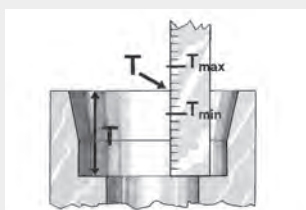

- Insertion depth T

Table: Tool for presetting tool (MOK and VOMO)

Type	T _{min}	T _{max}	Typ	T _{min}	T _{max}
6-L	6.95	7.05	6-S	6.95	7.05
8-L	6.95	7.05	8-S	6.95	7.05
10-L	6.95	7.05	10-S	7.45	7.55
12-L	6.95	7.05	12-S	7.45	7.55
15-L	6.95	7.05	14-S	7.95	8.05
18-L	7.45	7.55	16-S	8.45	8.55
22-L	7.45	7.55	20-S	10.45	10.55
28-L	7.45	7.55	25-S	11.95	12.05
35-L	10.45	10.55	30-S	13.45	13.55
42-L	10.95	11.05	38-S	15.95	16.05

EO2-FORM assembly instructions



Material combinations

- Select suitable materials
- See catalogue for exact tube specifications

Material selection chart

Tube material	Fitting and nut material	Sealing material
Steel	Steel	Steel/NBR or Steel/FKM
Stainless Steel	Stainless Steel	Stainless/Steel FKM/NBR
Stainless Steel	Steel	Steel/NBR or Steel/FKM



Tube preparation

- Cut and deburr thoroughly
- Cut and bend tubes exactly

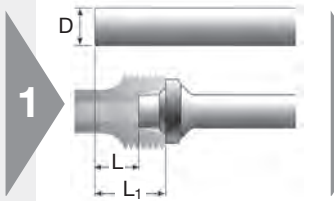

- Take extra length into account (see tube preparation chart)

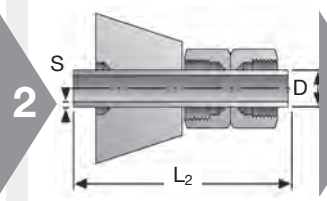

- Minimum lengths L_2 of straight tubes (see chart)

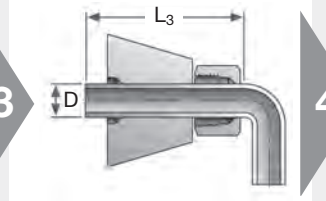

- Minimum lengths L_3 of straight tube-ends before bend (see chart)



- Cut tube squarely
- max $\pm 1^\circ$ deviation
- ⚠ Do not use pipe cutters
- EO tube-cutting tool (AV) for manual cutting



- Remove internal and external burrs
- max. chamfer $0.3 \text{ mm} \times 45^\circ$
- Recommendation: In-Ex Tube Deburring Tool 226

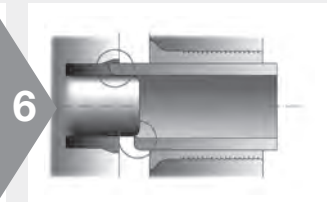

- Chips, dirt, internal or external burrs and paint prevent correct tube insertion
- ⚠ Dirty tubes result in worn-out or damaged tools

EO2-FORM assembly instructions

Tube preparation chart – Series L

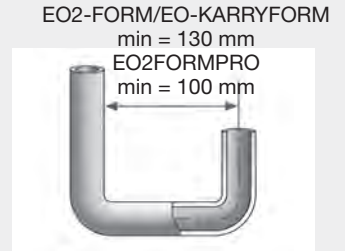
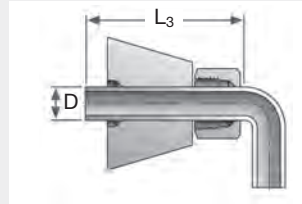
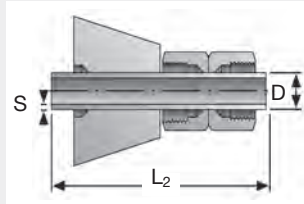
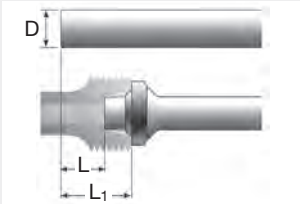

- Extra length
- Minimum tube length
- Minimum straight length before bend
- Minimum clearance of U-shape bends

Tube-OD Series	S Wall-thickness	L Steel ± 0.5	L Stainless steel ± 0.5	L ₁ Steel	L ₁ Stainless Steel	L ₂	L ₃
6L	1.0	6.0	6.0	13.0	13.0	90	63
	1.5	6.0	6.0	13.0	13.0		
	2.0	5.5		12.5			
8L	1.0	5.5	5.5	12.5	12.5	92	65
	1.5	5.5	5.5	12.5	12.5		
	2.0	5.0		12.0			
10L	1.0	5.5	5.5	12.5	12.5	95	68
	1.5	5.0	6.0	12.0	13.0		
	2.0	5.0	6.0	12.0	13.0		
12L	1.0	4.5	5.0	11.5	12.0	95	70
	1.5	5.0	5.5	12.0	12.5		
	2.0	5.0	5.5	12.0	12.5		
15L	1.0	5.0	6.5	12.0	13.5	102	75
	1.5	5.0	6.5	12.0	13.5		
	2.0	5.0	6.0	12.0	13.0		
	2.5	5.0		12.0			
18L	1.5	5.5	6.0	13.0	13.5	110	80
	2.0	5.5	6.5	13.0	14.0		
	2.5	6.0		14.0			
	3.0	6.0	6.5	14.0	14.0		
22L	1.5	6.0	6.0	13.5	13.5	120	90
	2.0	6.5	7.0	14.0	14.5		
	2.5	6.5	7.0	14.0	14.5		
	3.0	7.0	7.5	14.5	15.0		
28L	1.5	5.5	6.0	13.0	13.5	140	98
	2.0	5.5	7.0	13.0	14.5		
	2.5	7.0	7.5	14.5	15.0		
	3.0	7.0		14.5			
	4.0	6.5		14.0			
35L	2.0	7.0	8.5	17.5	19.0	170	115
	2.5	7.5	9.5	18.0	20.0		
	3.0	8.5	10.5	19.0	21.0		
42L	2.0	7.5	7.5	18.5	18.5	190	125
	3.0	9.0	10.5	20.0	21.5		
	4.0	9.0	10.5	20.0	21.5		
	5.0	10.0		21.0			

EO2-FORM assembly instructions

Tube preparation chart – Series S

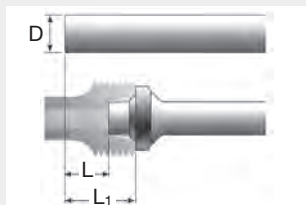

● Extra length

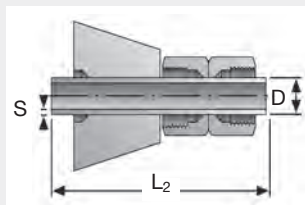

● Minimum tube length

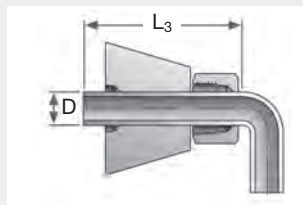

● Minimum straight length before bend

EO2-FORM/EO-KARRYFORM
min = 130 mm
EO2FORMPRO
min = 100 mm



● Minimum clearance of U-shape bends

E

Tube-OD Series	S Wall-thickness	L Steel ± 0.5	L Stainless Steel ± 0.5	L ₁ Steel	L ₁ Stainless Steel	L ₂	L ₃
6S	1.0	6.0	6.0	13.0	13.0	92	65
	1.5	6.0	6.0	13.0	13.0		
	2.0	5.5		12.5			
8S	1.0	5.5	5.5	12.5	12.5	95	68
	1.5	5.5	5.5	12.5	12.5		
	2.0	5.0		12.0			
10S	1.5	5.0	6.0	12.5	13.5	100	70
	2.0	5.0	6.0	12.5	13.5		
	3.0	4.5		12.0			
12S	1.5	5.0	6.5	12.5	14.0	100	72
	2.0	5.0	6.0	12.5	13.5		
	2.5	5.0	6.0	12.5	13.5		
	3.0	4.5	4.5	12.0	12.0		
16S	1.5	5.0	6.5	13.5	15.0	110	80
	2.0	5.5	6.5	14.0	15.0		
	2.5	5.5	6.5	14.0	15.0		
	3.0	5.0	6.5	13.5	15.0		
	4.0		6.0		14.5		
20S	2.0	7.0	7.0	17.5	18.5	135	98
	2.5	7.0	8.0	17.5	18.5		
	3.0	7.0	8.0	17.5	18.5		
	3.5	7.0		17.5			
25S	2.0	8.5	8.5	20.5	20.5	155	112
	2.5	8.5	9.0	20.5	21.0		
	3.0	8.0	9.5	20.0	21.5		
	4.0	8.5	9.5	20.5	21.5		
30S	2.0	8.0	8.5	21.5	22.0	165	122
	2.5	8.5	9.0	22.0	22.5		
	3.0	8.5	9.5	22.0	23.0		
	4.0	9.5	10.0	23.0	23.5		
	5.0	8.5	9.0	22.0	22.5		
38S	2.5	7.5	9.0	21.0	25.0	190	135
	3.0	10.0	9.5	26.0	25.5		
	3.5	10.0	11.5	26.0	27.5		
	4.0	10.0	11.0	26.0	27.0		
	5.0	11.0	12.5	27.0	28.5		
	6.0	11.5	12.5	27.5	28.5		
	7.0	11.5	12.5	27.5	28.5		

E02-FORM assembly instructions



Tube forming with E02-FORM F3/EO-KARRYFORM

- Reliable forming method
- Reliable process

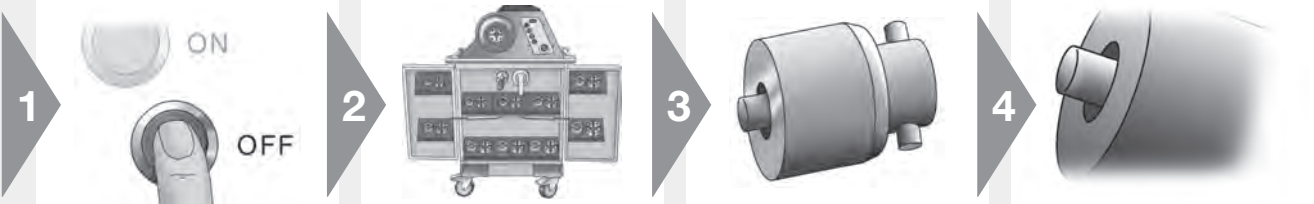

- 1**
- ⚠ Change tool only when drive switched off (button OFF)
 - ⚠ Obey safety instructions
 - ⚠ Do not operate machine without tooling

- 2**
- Open doors to access tools and handling devices
 - Tool handling devices are stored in middle on top

- 3**
- Select suitable forming pin according to tube material, outer diameter and wall thickness

- 4**
- Check forming pin for dirt, wear and damage

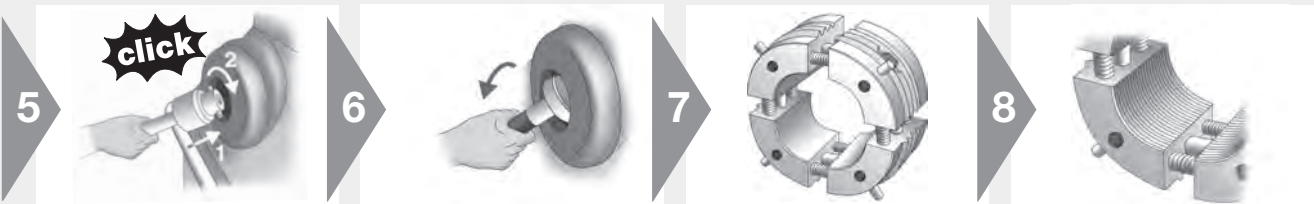

- 5**
- Use magnetic holder to insert forming pin
 - Turn clockwise to lock bayonet fixture

- 6**
- Tilt magneto holder to remove handle

- 7**
- Select suitable clamping die set according to tube outer diameter and material
 - ⚠ Keep stainless tube clamping dies separate from other tube materials to prevent contact corrosion

- 8**
- Check clamping dies for dirt, wear and damage
 - Use wire-brush to remove metal particles from grip surface

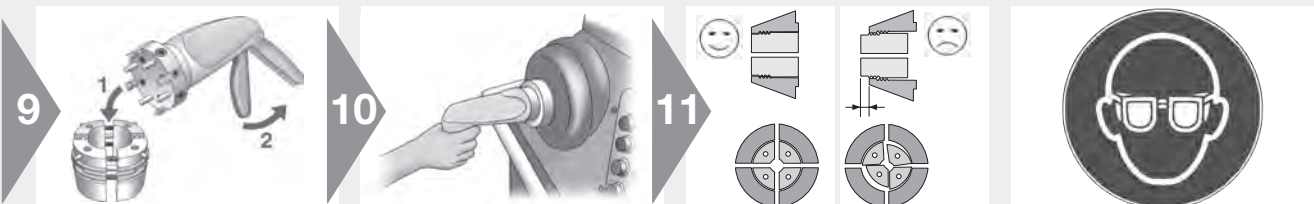

- 9**
- Use pistol to handle clamping die set
 - Pull and hold handle to grab die set

- 10**
- Insert clamping die set until it bottoms up (twist pistol for easy insertion)
 - Release handle to fix die set
 - ⚠ Never operate machine while pistol is inserted

- 11**
- ⚠ Front surfaces must be completely flat
 - ⚠ Die segments must fit without gaps

- ⚠ Wear safety glasses

EO2-FORM assembly instructions

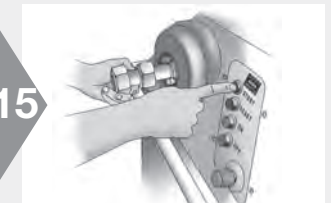
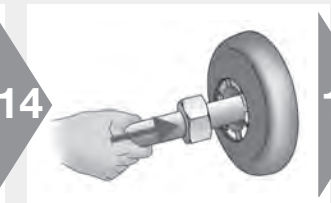
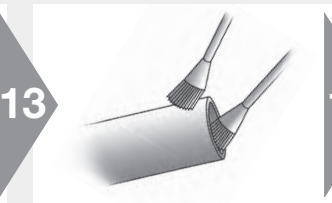
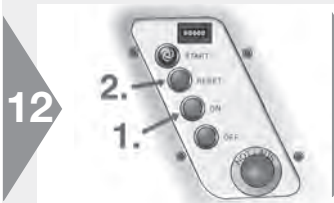

- Switch on drive (button ON)
- Each time the drive is switched on, the reset button (RESET) must be pressed first
- The automatic tool recognition is initiated
- ⚠ Clamping dies will close, reset button (RESET) must be held until it lights up
- Lighten of reset button (RESET) indicates "ready to start"

- ⚠ Make sure tube-end is free of burrs, chips and dirt
Lubricate inside and outside of tube-end
- Use EO-NIROMONT for best performance

- Insert tube-end with nut into open tool until it firmly touches the stop at the end
- ⚠ Press tube-end firmly into the tube stop
- ⚠ Do not turn tube-end anti-clockwise to prevent unlocking forming-pin

- Press and hold start button (@ START) until tube is clamped
- Instead of start-button (@ START), footswitch can be used
- ⚠ Hold tube firmly until clamping dies are closed
- Use support for long tubes
- ⚠ Do not reach into tool area while machine is working



- Tube can be taken out after the clamping dies are open
- Reset button (RESET) lights up and the machine is ready for the next operation
- Check tools regularly (approx. 50 assemblies) for dirt and wear
- Remove tools for cleaning
- Clean clamping dies with wire brush
- Clean forming die using compressed air
- Replace worn-out tooling

EO2-FORM assembly instructions



Assembly check

- Check assembly result
- ⚠ Incorrect assemblies must be scrapped

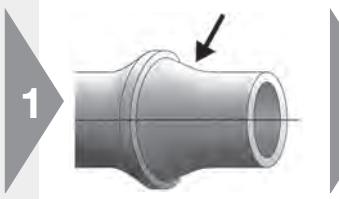

- Sealing surface (arrow) must be free of scratches and damage

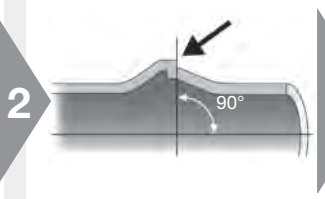

- Check contour: Contact surface for sealing ring (arrow) must be flat, at right angle to tube

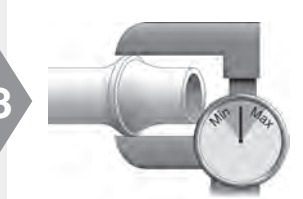

- Check outer diameter \varnothing ... (see chart)
- ⚠ Incorrect tube-ends must be scrapped. Tools must be cleaned and checked

Tube OD check

Tube \varnothing -Series	min \varnothing [mm]	max \varnothing [mm]
6-L/S	8.3	10.3
8-L/S	10.3	12.3
10-L	12.5	14.3
12-L	14.5	16.3
15-L	18.0	20.3
18-L	21.0	24.0
22-L	25.5	27.8
28-L	31.5	33.8
35-L	39.0	42.5
42-L	45.5	49.5
10-S	13.0	15.5
12-S	15.0	17.5
14-S	17.5	19.5
16-S	19.5	21.5
20-S	24.0	27.5
25-S	29.5	34.0
30-S	34.5	39.0
38-S	42.5*	47.0

* \varnothing 42.0 mm successfully tested with stainless steel tubes

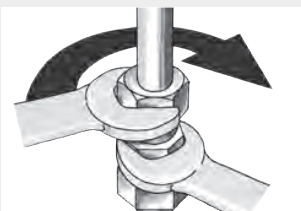

Installation

- ⚠ Tube must fit without tension

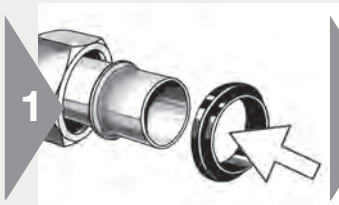

- Place sealing ring (DOZ) onto tube-end

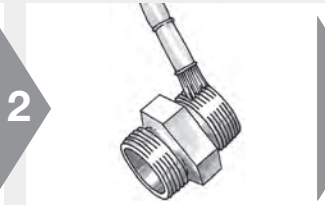

- Threads of stainless steel fittings must be lubricated
- EO-NIROMONT is a special high-performance lubricant for stainless steel fittings

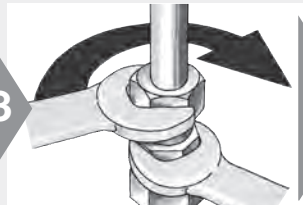

- Tube must fit without tension
- Assemble fitting until wrench-tight (without spanner extension)
- ⚠ The body must be held rigid

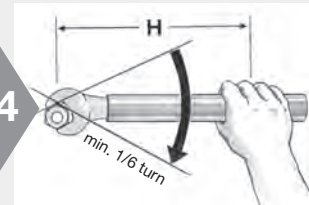

- ⚠ Then tighten fitting firmly by 1/6 turn (1 flat)
- ⚠ Recommended to use spanner extension for sizes over 20 mm O.D. (see chart)
- ⚠ Incorrect assembly reduces performance and reliability of the connection

Spanner length

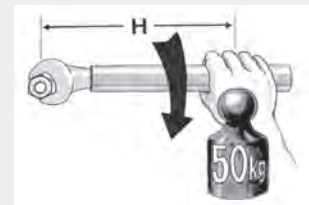

Size	Spanner length H [mm]
22-L	400
28-L 20-S	500
35-L 25-S	800
42-L 30-S	1000
38-S	1200

Checking instructions for EO2-FORM tools



Forming pin and clamping dies for EO2-FORM machine

- ⚠ Use of damaged, worn or non-suitable tooling may result in fitting failure and damage of machine
- ⚠ Tools must be checked regularly, at least after 50 assemblies
- ⚠ Worn tools must be replaced
- ⚠ Use only genuine Parker tools
- ⚠ Tools must always be kept clean and lubricated

1

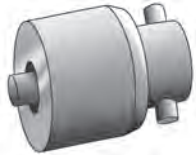

- Clean forming pin for checking
- Do not disassemble

2



- Visual check:
Surface must be free of wear and damage
- Use air blowgun to remove chips and dirt

3



- Clean clamping pin for checking
- Do not disassemble
- Pins must not be loose or damaged

4

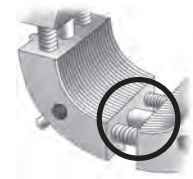

- Visual check:
Grip surface must be clean and free of wear
- Use wire-brush to remove metal particles from grip surface
- Check springs and connection bolts

E

Weld fitting

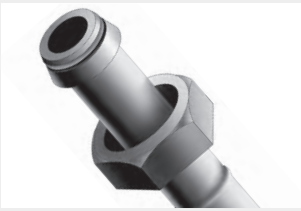

Weld fitting assembly

- EO weld nipple and weld fitting
- ⚠ Use weldable material
- ⚠ Depending on application or project specification, special requirements may apply for: Tube preparation, welding process, operator qualification, inspection of welding connection and surface finish



Tube preparation

- Cut and deburr thoroughly
- Do not assemble under tension

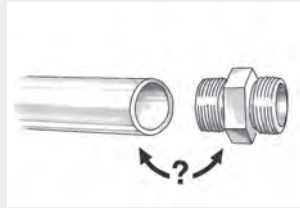

Material combinations

- Select suitable tube material

Fitting material	Tube specification
Steel	Weldable Steel
Stainless Steel	Weldable Stainless Steel

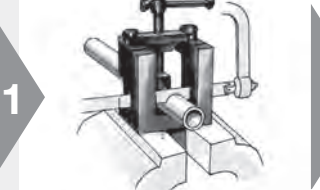

1

- Cut tube squarely
- max $\pm 1^\circ$ deviation
- ⚠ Do not use pipe cutters
- EO tube-cutting tool (AV) for manual cutting

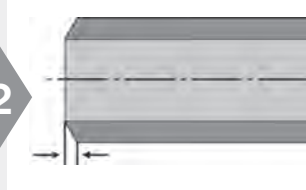

2

- Bevel tube-end similar to weld nipple bevel

Assembly

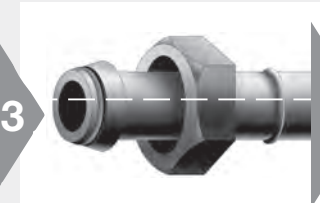

3

- Slide nut onto tube-end
- Weld fitting onto tube-end
- Fitting and tube must be aligned
- ⚠ Remove all elastomeric seals before welding



4

- Clean weld
- Calibrate inner diameter
- Check welding quality
- Surface protection if necessary

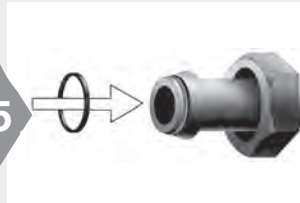

5

- Assemble O-ring
- Lubricate O-ring for easy assembly
- Avoid damage or twisting of O-ring



6

- ⚠ Threads of stainless steel fittings must be lubricated
- ⚠ Use EO-NIROMONT special high-performance lubricant for stainless steel fittings



7

- Assemble fitting until wrench-tight (without spanner extension)

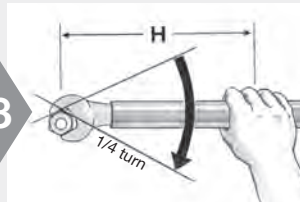

8

- ⚠ Then tighten fitting firmly by $\frac{1}{4}$ turn ($1\frac{1}{2}$ flats)
- ⚠ The body must be held rigid

O-Lok® assembly instructions



Tube selection

- Select suitable tube material

Steel tube		Stainless Steel tube
Cold drawn seamless	Welded & redrawn	Cold drawn seamless
NF A 49330	NF A 49341	
ISO 3304 R	DIN 2393	NF A 49341
DIN 2391C pt 1	BS 3602/2	DIN 17458 DA/T3
BS 3602 pt1	SAE J525	ASTM A 269
SAE J524		1.4571 on request



Tube preparation

- Cut and deburr thoroughly

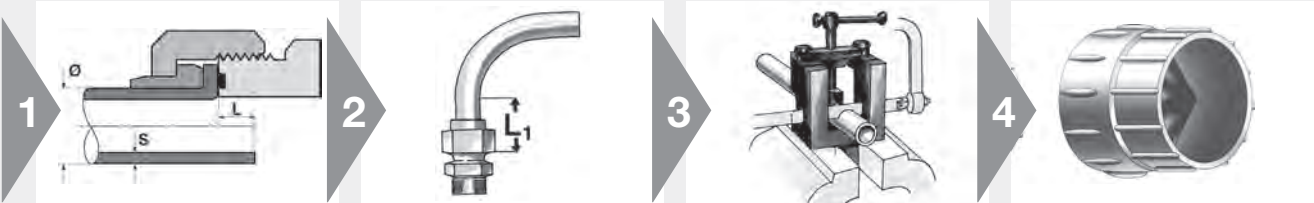

- Calculate tube length before cutting
- Add extra length "L"

- Minimum length of straight tube-ends (see chart below)

- Cut tube squarely
- max. ±1° deviation
- ⚠ Do not use pipe cutters
- Use tube-cutting tool AV for manual cutting

- Remove internal and external burrs
- max. chamfer 0.3 mm × 45°
- Recommendation: In-Ex Tube Deburring Tool 226
- ⚠ Proper deburring and cleaning of inner diameter essential for sealing surface quality

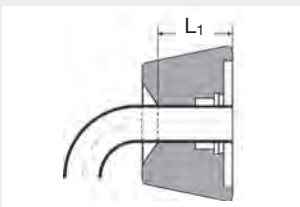

Metric tube [mm]		Minimum straight length to start to bend L1 [mm]	Extra length ~ L [mm] for Tube Wall thickness							
Tube Ø	Wall thickness		1	1.5	2	2.5	3	3.5	4	5
6	1.0 – 1.5	40	4.5	5.5						
8	1.0 – 2.0	40	5.0	5.0						
10	1.0 – 2.0	40	2.5	4.0	3.5					
12	1.0 – 3.0	50	3.5	4.5	4.5	4.0	4.0			
14	1.5 – 2.0	50			5.0					
15	1.0 – 2.0	50		4.5	5.0					
16	1.5 – 3.0	50		3.0	3.0	3.0	2.5			
18	1.5 – 2.0	50		6.0	5.5					
20	2.0 – 3.5	50			3.5	4.0	4.0	3.5		
22	1.5 – 2.5	50			6.5	7.0				
25	2.0 – 4.0	50				4.0	4.5		4.0	
28	1.5 – 3.0	50			6.0	7.0				
30	2.0 – 4.0	50			5.0				5.0	
32	2.0 – 4.0	50							3.5	
35	2.0 – 3.0	50							7.0	
38	2.0 – 5.0	50							5.0	4.5
50	3.0	50							4.0	

Inch tube [inch]		Minimum straight length to start to bend L1 [mm]	Extra length ~ L [mm] Tube Wall thickness										
Tube Ø	Wall thickness		0.028"	0.035"	0.049"	0.065"	0.083"	0.095"	0.109"	0.120"	0.134"	0.156"	0.188"
1/4"	0.020 – 0.065	40	4.5	5.0	4.0								
3/8"	0.020 – 0.095	40		3.5	3.5	4.0	4.0	4.0					
1/2"	0.028 – 0.095	50		3.5	3.5	3.5	3.5	3.5					
5/8"	0.035 – 0.120	50			4.0	4.0	3.0	4.5	4.0	4.5			
3/4"	0.035 – 0.156	50			4.0	4.0	3.0	2.5	3.5	4.0	4.5		
1"	0.035 – 0.188	50				3.5	3.5	2.5	4.5	4.5	5.0		
1 1/4"	0.049 – 0.188	50					4.0	3.0	3.0	3.0	4.0	4.5	4.5
1 1/2"	0.049 – 0.220	50					4.5	4.5	5.0	5.0	5.0	6.0	5.5
2"	0.083 – 0.120	50						4.0	4.0		5.0		

O-Lok® assembly instructions



Parflange® 50



Parflange® 1025

O-Lok® machine flanging and assembly

- Preferred method
- Most efficient method
- Parflange® recommended



1

Parflange® machines:

- Select flaring pin according to tube dimensions
- Use special "SS" pin for stainless steel tube
- Pin must be clean and free of wear, damage and metal particles
- Keep flaring pin clean and lubricate regularly



2

- Select flanging dies according to tube dimensions
- Use special "SS" dies for stainless steel tube to avoid contact corrosion
- Grip surface must be clean and free of wear
- Use only genuine Parker tooling for flanging O-Lok®



3

- Load pin into machine
- Ensure lubricating system is filled with EO-NIROMONT (LUBSS)



4

- Place sleeve in lower die half
- Locate upper die half onto lower half



5

- Place the dies in the die housing
- 50: Close safety cover



6

- Slide nut onto tube before flanging!
- Open threads towards machine

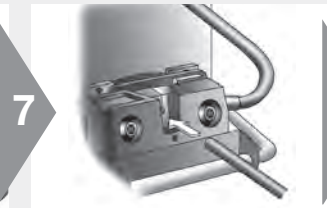

7

- ⚠ Press tube firmly into the die against the tube stop



8

- Pull down the handle to clamp the tube in the dies (1025)
- 1040/50 die clamping automatic in cycle
- Press button to start flanging cycle
- ⚠ Keep hands clear off the working area

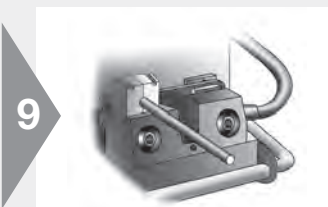

9

- Parflange® 1025: Unclamp the dies
- Remove tube from machine
- Use die separator to free tube
- Parflange® 1040/50: Die unclamping is automatic

O-Lok® assembly instructions

Checking of flange



- 1
- Clean flange for inspection
 - ⚠ Check sealing surface for cracks, burrs, scratches and pitting



- 2
- Dimensional check of the flare
 - Flare O.D. should not exceed outside sleeve diameter
 - Flare O.D. should not be less than smaller diameter of front of sleeve
 - When in doubt, measure



Tube O.D.		Ø D	
mm	In.	min. [mm]	max. [mm]
6	1/4"	12.10	12.75
8		14.85	15.75
10	3/8"	14.85	15.75
12	1/2"	18.00	18.90
14		22.20	23.45
15		22.20	23.45
16	5/8"	22.20	23.45
18		26.60	27.85
20	3/4"	26.60	27.85
22		32.95	34.20
25	1"	32.95	34.20
28		39.35	40.55
30		39.35	40.55
32	1 1/4"	39.35	40.55
35		47.25	48.50
38	1 1/2"	47.25	48.50
50	2"	58.90	60.60

Installation in fitting



- 1
- ⚠ Steel fittings: No thread lubrication
 - ⚠ Stainless steel fittings: O-ring and thread lubrication required
 - EO-NIROMONT is a special high-performance lubricant for stainless steel fittings

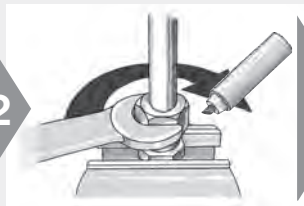

- 2
- Thread nut onto body
 - Tighten until no relative movement between the components
 - Mark body and nut as quality check

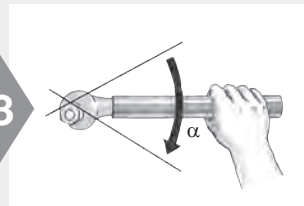

- 3
- Tighten to recommended torque level
 - Recommended: Tighten with spanner the number of flats indicated α
 - 1 flat = 60°
 - ⚠ The body must be held rigid

Tightening recommendation

Metric tube [mm]	Inch tube [Inch]	SAE dash size	SAE thread	recommended		reference	
				Tube	Swivel	Assembly torque Nm -0% + 10%	
						Steel	Stainless Steel
6	1/4"	-4	9/16-18	1/4 - 1/2	1/2 - 3/4	25	32
8	3/8"	-6	11/16-16	1/4 - 1/2	1/2 - 3/4	40	50
10	3/8"	-6	11/16-16	1/4 - 1/2	1/2 - 3/4	40	50
12	1/2"	-8	13/16-16	1/4 - 1/2	1/2 - 3/4	65	70
14	5/8"	-10	1-14	1/4 - 1/2	1/2 - 3/4	80	100
15	5/8"	-10	1-14	1/4 - 1/2	1/2 - 3/4	80	100
16	5/8"	-10	1-14	1/4 - 1/2	1/2 - 3/4	80	100
18	3/4"	-12	1 3/16-12	1/4 - 1/2	1/3 - 1/2	115	145
20	3/4"	-12	1 3/16-12	1/4 - 1/2	1/3 - 1/2	115	145
22		-16	1 7/16-12	1/4 - 1/2	1/3 - 1/2	150	190
25	1"	-16	1 7/16-12	1/4 - 1/2	1/3 - 1/2	150	190
28	1 1/4"	-20	1 11/16-12	1/4 - 1/2	1/3 - 1/2	190	235
30	1 1/4"	-20	1 11/16-12	1/4 - 1/2	1/3 - 1/2	190	235
32	1 1/4"	-20	1 11/16-12	1/4 - 1/2	1/3 - 1/2	190	235
35	1 1/2"	-24	2-12	1/4 - 1/2	1/3 - 1/2	245	305
38	1 1/2"	-24	2-12	1/4 - 1/2	1/3 - 1/2	245	305
50	2"	-32	2 1/2-12	-	-	-	490

* "Flats From Wrench Resistance" Method for steel and stainless steel

O-Lok® assembly instructions



O-Lok®: Replacement of O-ring

- Parker CORG assembly tool should be used for O-Lok® fitting with captive O-ring groove (O-Lok®)



1

- Insert the O-ring into the slot located on the side of the tool



2

- Position the open end of the tool over the tube-end of the fitting

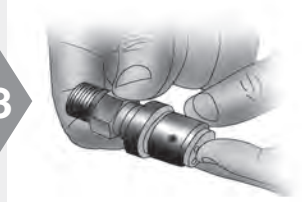

3

- Push the piston of the tool until the O-ring is released into the fitting groove

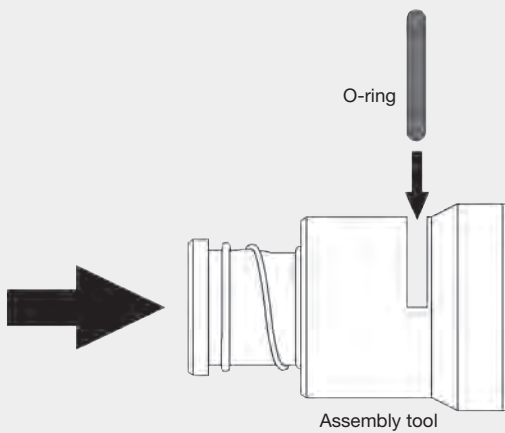

- Function of Parker CORG assembly tool

Triple-Lok® assembly instructions



Tube selection

- Select suitable tube material

Steel tube		Stainless steel tube
Cold drawn seamless	Welded & redrawn	Cold drawn seamless
NF A 49330	NF A 49341	
ISO 3304 R	DIN 2393	NF A 49341
DIN 2391C pt 1	BS 3602/2	DIN 17458 DA/T3
BS 3602 pt1	SAE J525	ASTM A 269
SAE J524		



Tube preparation

- Cut and deburr thoroughly

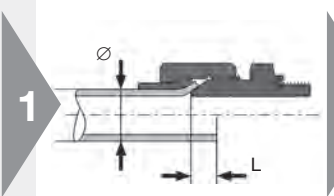

- 1
- Calculate tube length before cutting
 - Add extra length "L"



- 2
- Minimum length L₁ of straight tube-ends (see chart below)

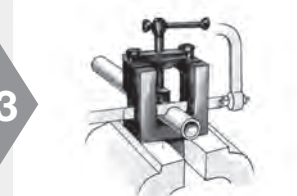

- 3
- Cut tube squarely
 - max. ±1° deviation
 - ⚠ Do not use pipe cutters
 - Use tube cutting tool AV for manual cutting



- 4
- Remove internal and external burrs
 - max. chamfer 0.3 mm × 45°
 - Recommendation: In-Ex Tube Deburring Tool 226
 - ⚠ Proper deburring and cleaning of inner diameter essential for sealing surface quality

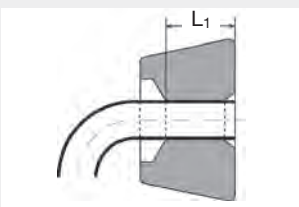

Tube preparation chart

Metric tube [mm]		Inch tube [inch]		Extra length ~ L [mm]	Minimum straight length to start to bend L ₁ [mm]	Flare Ø Ø D [mm]
Tube Ø	Wall thickness	Tube Ø	Wall thickness			
6	1.0 – 1.5	1/4"	0.020 – 0.065	2.0	40	8.6 – 9.7
8	1.0 – 1.5	5/16"	0.020 – 0.065	2.0	40	10.2 – 11.3
10	1.0 – 1.5	3/8"	0.020 – 0.065	2.0	42	11.7 – 12.7
12	1.0 – 2.0	1/2"	0.028 – 0.083	2.5	43	16.0 – 17.3
14	1.5 – 2.0			2.5	52	19.3 – 20.2
15	1.0 – 2.5			2.5	52	19.3 – 20.2
16	1.5 – 2.5	5/8"	0.035 – 0.095	2.5	52	19.3 – 20.2
18	1.5 – 3.0			3.0	56	23.4 – 24.7
20	2.0 – 3.0	3/4"	0.035 – 0.109	3.0	57	23.4 – 24.7
22	1.5 – 3.0			3.0	58	26.5 – 27.8
25	2.0 – 3.0	1"	0.035 – 0.120	3.0	58	29.7 – 31.0
28	1.5 – 3.0			4.0	65	37.6 – 38.9
30	2.0 – 3.0			4.0	65	37.6 – 38.9
32	2.0 – 3.0	1 1/4"	0.049 – 0.120	4.0	65	37.6 – 38.9
35	2.0 – 3.0			4.0	70	43.2 – 45.3
38	2.0 – 4.0	1 1/2"	0.049 – 0.120	4.0	70	43.2 – 45.3
42*	2.0 – 3.0			5.0	80	52.0 – 54.8
50	2.0 – 3.5	2"	0.058 – 0.134	5.0		59.2 – 61.2

- * Tube OD 42 mm:
- 1015: not suitable
- KARRYFLARE: special flaring pin KARRYFLARE/FPIN42 required

Triple-Lok® assembly instructions

37° Flaring Parflange®-Process

- Preferred method
- Most efficient method
- Parflange® recommended

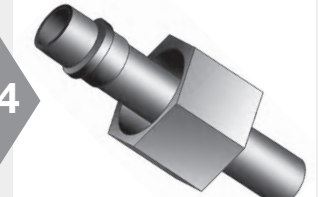
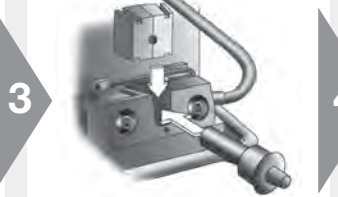
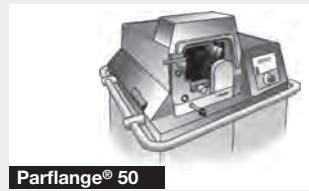

- Select flaring pin according to tube dimensions
- Use special "SS" pin for stainless steel tube
- Pin must be clean and free of wear and damage
- Load tooling into machine
- Keep flaring pin clean and lubricate regularly

- Select flaring dies according to tube dimensions
- Use special "SS" dies for stainless steel tube
- Grip surface must be clean and free of wear
- Use only genuine Parker tooling for flaring Triple-Lok®

- Load tooling into machine
- Keep sliding surfaces clean and lubricated
- 50: Close safety cover
- Ensure lubricant system is filled with EO-NIROMONT (LUBSS)

- Slide nut and sleeve as shown onto the tube-end

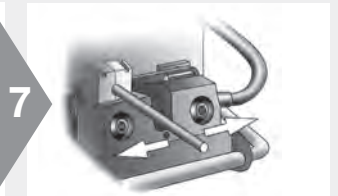

- ⚠ Press tube firmly into the die against the tube stop
- Parflange® 1025: Operate clamping lever
- Parflange® 1040/50: Automatic tube clamping

- Hold tube firmly
- Press start button
- ⚠ Keep hands clear off the working area

- Parflange® 1025: Unclamp the dies
- Parflange® 1040/50: Die unclamping is automatic
- Remove tube from machine
- Use die separator to free tube

Triple-Lok® assembly instructions

37° Flaring with EOMAT/KARRYFLARE/Parflare ECO

- Preferred method
- Most efficient method
- Parflange® recommended



EOMAT UNI



KARRYFLARE

E

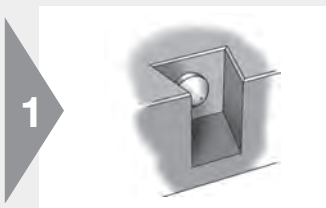

1

- Flaring pin is integrated in flaring block
- Pin must be clean and free of wear and damage
- Keep flaring pin clean
- KARRYFLARE: Flaring pin for 42 mm tube O.D. must be fitted with flat face on top

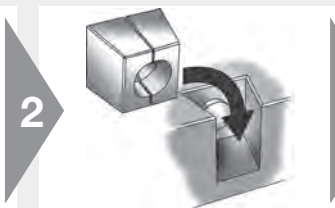

2

- Select flaring dies according to tube O.D.
- Grip surface must be clean and free of wear
- Use only genuine Parker tooling for flaring Triple-Lok®
- Keep sliding surfaces clean and lubricated

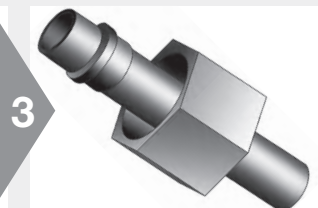

3

- Slide nut and sleeve as shown onto the tube-end



4

- Lubricate tube-end inside
- Lubricant EO-NIROMONT recommended

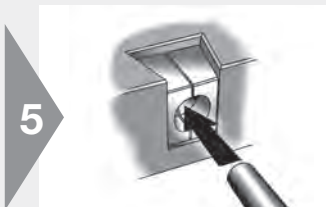

5

- ⚠ Press tube firmly into the die against the tube stop
- KARRYFLARE: Close valve on handpump
- KARRYFLARE: Keep lid closed



6

- EOMAT UNI: Adjustment according to pressure on machine
- EOMAT III/A: Menu selection (FLARE)
- KARRYFLARE: Refer to chart on machine
- Non-EOMAT-machines: check suitability



7

- Hold tube firmly
- EOMAT: Press and hold start button
- KARRYFLARE: Operate handpump until assembly pressure is reached
- ⚠ Keep hands clear off the working area
- ⚠ KARRYFLARE: Do not exceed max pressure 400 bar

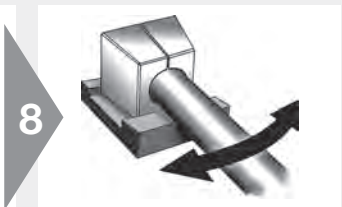

8

- KARRYFLARE: Open valve on handpump
- Remove tube from machine
- Use die separator to free tube

Triple-Lok® assembly instructions

Checking the flare



- 1
- Clean flare for inspection
 - ⚠ Visual check sealing surface for cracks, burrs, scratches and pitting

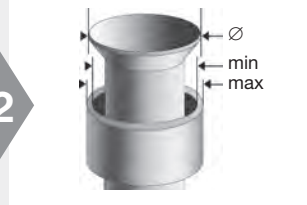

- 2
- Dimensional check of the flare
 - Flare O.D. should not exceed outside sleeve diameter
 - Flare O.D. should not be less than smaller diameter of front of sleeve
 - When in doubt, measure

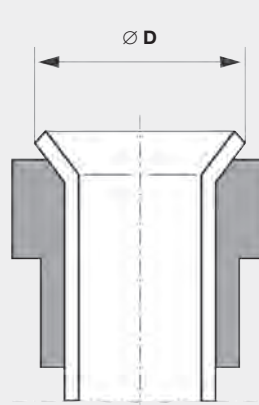

Tube O.D.		Ø D	
mm	inch	Min.	Max.
6	1/4"	8.6	9.7
8	5/16"	10.2	11.3
10	3/8"	11.7	12.7
12	1/2"	16.0	17.3
14		19.3	20.2
15		19.3	20.2
16	5/8"	19.3	20.2
18		23.4	24.7
20	3/4"	23.4	24.7
22	7/8"	26.5	27.8
25	1"	29.7	31.0
28		37.6	38.9
30		37.6	38.9
32	1 1/4"	37.6	38.9
35		43.2	45.3
38	1 1/2"	43.2	45.3
42		52.0	54.8
50	2"	59.2	61.2

Installation

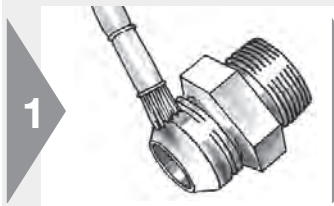

- 1
- Steel fittings: No lubrication
 - Stainless steel fittings: Lubrication required
 - Use EO-NIROMONT special high-performance lubricant for stainless steel fittings

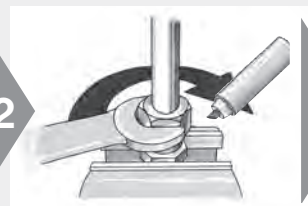

- 2
- Thread nut onto body
 - Tighten to full metal contact (wrench tight)
 - Mark body and nut as quality check
 - Tighten with spanner the number of flats indicated
 - ⚠ The body must be held rigid

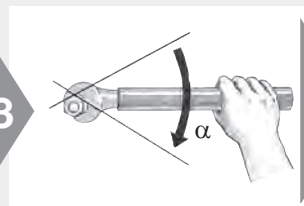

- 3
- Use spanner extension for larger fittings (28 mm)

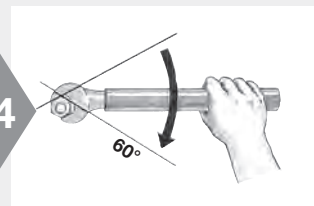

- 4
- 1 flat = 60°

Tightening recommendation

Metric tube [mm]	Inch tube [Inch]	SAE thread	recommended				reference	
			α flats from wrench tight for steel		α flats from wrench tight for stainless steel		Assembly torque Nm -0% + 10%	
			Tube	Swivel	Tube	Swivel	Steel	Stainless steel
6	1/4"	7/16-20	2	2	2	2	18	30
8	3/8"	1/2-20	2	2	2	2	20	40
10	3/8"	9/16-18	2	1.5	1.5	1	30	60
12	1/2"	3/4-16	2	1.5	1.5	1	57	115
14	5/8"	7/8-14	1.5	1.5	1.5	1	81	145
15	5/8"	7/8-14	1.5	1.5	1.5	1	81	145
16	5/8"	7/8-14	1.5	1.5	1.5	1	81	145
18	3/4"	1 1/16-12	1.5	1.25	1.25	1	114	180
20	3/4"	1 1/16-12	1.5	1.25	1.25	1	114	180
22		1 3/16-12	1.5	1.25	1	1	136	225
25	1"	1 5/16-12	1.5	1	1	1	160	255
28	1 1/4"	1 5/8-12	1	1	1	1	228	295
30	1 1/4"	1 5/8-12	1	1	1	1	228	295
32	1 1/4"	1 5/8-12	1	1	1	1	228	295
35	1 1/2"	1 7/8-12	1	1	1	1	265	345
38	1 1/2"	1 7/8-12	1	1	1	1	265	345
42		2 1/4-12	1	1	1	1	340	400

Checking instructions for O-Lok®/Triple-Lok® tools



Tools for Parflange® machines

- ⚠ Use of damaged, worn or non-suitable tooling may result in fitting failure and damage of machine
- ⚠ Tools must be checked regularly, at least after 50 assemblies
- ⚠ Worn tools must be replaced
- ⚠ Use only genuine Parker tools
- ⚠ Tools must always be kept clean and lubricated

1



- Clean pin for checking

2



- Visual check:
Surface must be free of wear and damage

3



- Clean die halves for checking
- ⚠ Do not disassemble
- Fixing pins must not be loose or damaged

4



- Visual check:
Grip surface must be clean and free of wear
- Use wire-brush to remove metal particles from grip surface



Adjustment of Parflange® dies

- Parflange® dies can be adjusted to correct deviations of flare diameter
- ⚠ Re-adjustment of dies will not help if general machine setting is incorrect or components are damaged (worn tube-stop, lose screw connections)

1



- To reduce the flare diameter, turn the screws anti-clockwise
- ⚠ Re-adjust both screws simultaneously

2

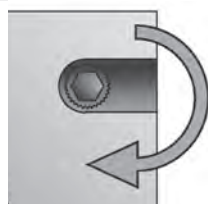

- To increase the flare diameter, turn the screws clockwise
- ⚠ Re-adjust both screws simultaneously
- 1 click = approx. 0.05 mm ∅

3



- Adjust the screws in small stages
- Then check flare diameter
- ⚠ Lock screws to prevent misadjustment

Ferulok® assembly instruction

Tube preparation

- Cut and deburr thoroughly
- Do not assemble under tension

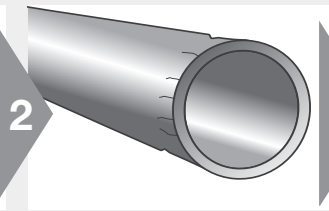
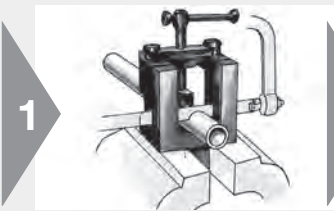

- Cut tube squarely
 - max $\pm 1^\circ$ deviation
 - ⚠ Do not use pipe cutters
 - EO tube-cutting tool (AV) for manual cutting

- Don't deform tube end at cutting or bending
 - Marks or scratches can result in leakage
 - Thin wall and soft tubes are very sensitive

- Remove internal and external burrs
 - max. chamfer 0.3 mm x 45°

Ferrule Preset

Prior to final installation the Ferulok® fitting requires a pre-setting operation that creates a bite by the ferrule into the outer surface of the tubing. Pre-setting can be accomplished by two different methods: hydraulically, using a Hyferset tool or a Hydra-Tool, or manually, using a hardened Ferruleset tool or the fitting body.

Pre-setting using Ferulset tool or fitting body

Ferulset pre-setting tools are made from hardened steel and are recommended over the fitting body because they can be used repeatedly to perform the pre-set operation. The fitting body can only be used once for pre-setting and should be used during final installation with the pre-set tube line. The following steps are required for proper pre-set of the ferrule using the Ferruleset tool or fitting body.



- Lubricate thread and cone of Ferrulset tool (or fitting body)

- Slip nut and ferrule over deburred tube end. Be sure the long, straight end of the ferrule points toward tube end

- Lubricate ferrule with system fluid or a compatible lubricant

- Bottom tube end firmly on internal shoulder of Ferrulset tool (or fitting body)



- Manually screw nut onto Ferrulset tool or fitting body until finger tight

- Make reference mark on nut and tube

- Hold tube steady against internal shoulder of Ferrulset tool or fitting body and tighten nut an additional **1 3/4 turns**

- Loosen nut and check for proper pre-set. Use the following inspection criteria.

Ferulok® assembly instruction

Pre-setting with Hyferset Tool or Hydra-Tool

Pre-setting with hydraulic equipment (Hyferset or Hydra-tool) is preferred for fittings larger than size 8 or large production quantities in any size.

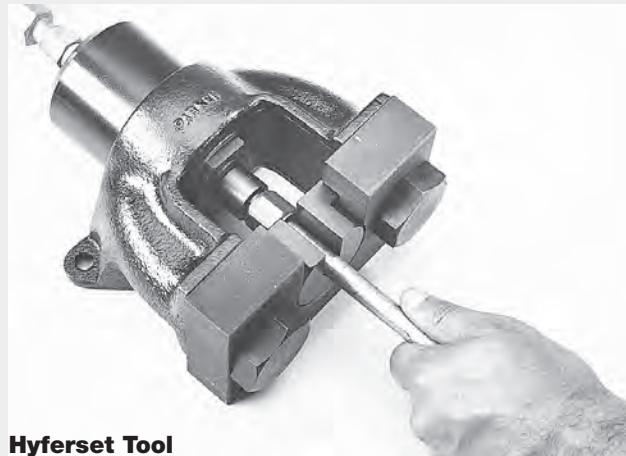

Hyferset Tool

Pre-set inspection

All Ferulok fitting presets must be disassembled and inspected for correct ferrule pre-set before final installation. The following detailed inspection procedures must be followed regardless of the method used to pre-set the ferrule to the tube. (Refer to the figure below for the following five inspection points.

1. A ridge of metal (A) has been raised above the tube surface to a height of at least 50 % of the ferrule's leading edge, completely around the tube.
2. While the leading edge of the ferrule may be coined flat (B) there is a slight bow to the balance of the pilot section (C).
3. The tail or back end of the ferrule is snug against the tube (D).
4. There is a slight indentation around the end of the tube (E) that indicates the tube was bottomed in the tool or fitting during pre-setting.
5. Avoid rotating the ferrule. Steel ferrules should not be capable of moving back and forth along the tube beyond the bite area (a stainless steel ferrule will move more than steel because of its spring back characteristics).

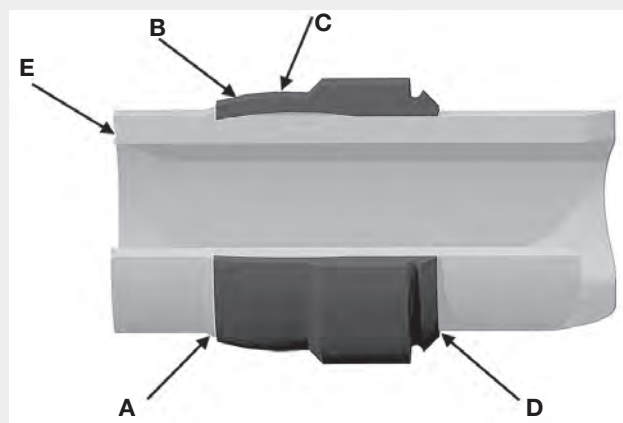

Installation

If the fitting body was used for pre-setting the ferrule, complete the final installation with the **same** fitting body. Following the pre-setting and inspection, select the compatible fitting body and lubricate the threads. Tighten the nut until a sudden and noticeable wrench resistance is achieved. Then wrench an additional 1/6 to 1/4 turn to complete the final assembly. Final assembly of swivel nut fittings is achieved by turning the nut 3/4 turn from wrench resistance position.

Ferulok® assembly instruction

Hydra-tool Pre-setting pressures for Ferulok® fittings¹⁾²⁾³⁾

Tube Size	Wall Thickness - Steel							Wall Thickness Stainless Steel						
	0.035	0.049	0.065	0.083	0.095	0.109	0.120	0.035	0.049	0.065	0.083	0.095	0.109	0.120
4	300	300	500	600	600	600		300	300	500	700	700	700	
6	300	500	600	700	700	700	700	300	500	700	700	700	700	800
8		500	700	800	900	1.000	1.000		600	700	1.000	1.000	1.100	1.100
10			700	900	1.000	1.100	1.100			800	1.000	1.100	1.300	1.300
12			900	1.000	1.100	1.100	1.300			1.000	1.100	1.300	1.300	1.500
14			1.000	1.100	1.100	1.300	1.500			1.000	1.300	1.300	1.500	1.600
16				1.100	1.300	1.500	1.600				1.500	1.500	1.600	1.600
20					1.500	1.600	1.800					1.600	2.000	2.000
24					1.800	2.000	2.300					2.100	2.300	2.300
32					2.800	2.900	3.300					3.100	3.300	3.300

1. These values are provided as a guide only and normally will produce a satisfactory bite.
2. Ferulok® pre-setting dies are positive stop dies. Use of above pressures is optional.
3. For wall thicknesses greater than those listed, contact the Tube Fittings Division.

Hyferset Pre-setting for Ferulok® fittings¹⁾

Tube Size	Wall thickness - Steel							Wall thickness - Stainless Steel						
	0.035	0.049	0.065	0.083	0.095	0.109	0.120	0.035	0.049	0.065	0.083	0.095	0.109	0.120
4	800	900	1400	1800	1.800	1.800		900	1.000	1.500	2.000	2.000	2.000	
6	900	1.400	800	2.000	2.000	2.000	2.200	1.000	1.500	2.000	2.000	2.000	2.000	2.500
8		1.600	2.000	2.500	2.700	3.000	3.200		1.800	2.200	3.000	3.000	3.500	3.500
10			2.200	2.700	3.000	3.500	3.500			2.500	3.000	3.500	4.000	4.000
12			2.700	3.000	3.500	3.500	4.000			3.000	3.500	4.000	4.000	4.500
14			3.000	3.500	3.500	4.000	4.500			3.000	4.000	4.000	4.500	5.000
16				3.500	4.000	4.500	5.000				4.500	4.500	5.000	5.000
18				4.000	4.500	4.500	5.000				4.500	5.000	5.000	5.500
20					4.500	5.000	5.500					5.000	6.000	6.000
24					5.500	6.000	7.000					6.500	7.000	7.000
28					7.000	7.500	8.000					7.500	8.000	8.500
32					8.500	9.000	10.000					9.500	10.000	10.000

1. Ferulok® pre-setting dies are positive stop dies. Use of above pressures is optional.



Fitting assembly



Table of contents

Port connections M	F4
Port connections BSPP	F5
Port connections UNF	F6
Port connections TAPER	F7
Adjustable fittings with locknut.....	F8
EO swivels	F9
Triple-Lok® / O-Lok® swivels	F10
Flanges	F11
Replacement / DA.....	F12
Tube bending.....	F13
Tube line fabrication guide.....	F14

F

Port connections



Assembly of metric straight port connections

- Metric Thread
DIN ISO 6149-2/3
ISO 9974-2/3
DIN 3859-T2

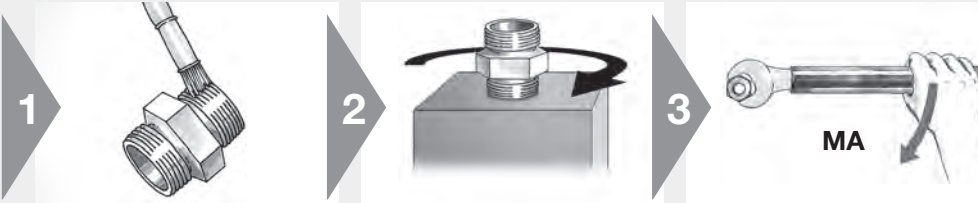

- ⚠ Threads of stainless steel fittings must be lubricated
- EO-NIROMONT is a special high-performance lubricant for stainless steel fittings
- Screw in until handtight
- Then tighten according to chart

Assembly torques for zinc plated steel fittings with metric thread in ports made of steel

Product	Tube O.D.	Straight male stud fittings with port tapping						Non return valves RHV/RHZ Form E with ED-sealing Nm	EO Banjo fittings			Adjustable ends		Blanking plugs		
		Thread size T	Form A for sealing washer	Form B with face	Form E with ED-sealing	Form F with O-Ring-sealing	Form G with O-Ring and retaining ring		WH/TH	SWVE	DSWW	ISO 9974 O-Ring and retaining ring	DIN ISO 6149-2/3 O-Ring	oiled VSTI-ED Form E with ED-sealing	oiled VSTI-OR Form F with O-Ring-sealing	
Series		mm	Nm	Nm	Nm	Nm	Nm	Nm	Nm	Nm	Nm	Nm	Nm	Nm	Nm	Nm
EO L Triple-Lok®	6	M 10x1.0	9	18	18	15	18	18	18	25	30	18	15	12	18	
	8	M 12x1.5	20	30	25	25	35	25	45	40	40	25	25	25	30	
	10	M 14x1.5	35	45	45	35	45	35	55	55	50	40	35	35	40	
	12	M 16x1.5	45	65	55	40	55	50	80	65	65	55	40	50	50	
	15	M 18x1.5	55	80	70	45	70	70	100	90	85	70	45	65	70	
	18	M 22x1.5	65	140	125	60	160	125	140	130	130	90	60	90	100	
	22	M 26x1.5	90	190	180	100*	250	145	320	140	190	180	100	135		
	28	M 33x2.0	150	340	310	160	310	210	360		245	310	160	225	310	
	35	M 42x2.0	240	500	450	210	450	360	540		305	450	210	360	330	
42	M 48x2.0	290	630	540	260	540	540	700		365	540	260	360	420		
EO S O-Lok®	6	M 12x1.5	20	35	35	35		35	45	40	40	35	35	25	35	
	8	M 14x1.5	35	55	45	45		45	55	55	50	45	45	35	45	
	10	M 16x1.5	45	70	70	55		55	80	65	65	55	55	50	55	
	12	M 18x1.5	55	110	90	70		70	100	90	85	70	70	65	70	
	14	M 20x1.5	55	150	125	80		100	125	120	105	90	90	80	80	
	16	M 22x1.5	65	170	135	100		125	135	130	130	90	100	90	100	
	20	M 27x2.0	90	270	180	170		135	320	150	200	190	170	120	170	
	25	M 33x2.0	150	410	310	310		210	360		245	310	310	225	310	
	30	M 42x2.0	240	540	450	330		360	540		305	450	330	360	330	
	38	M 48x2.0	290	700	540	420		540	700		365	540	420	360	420	

Tolerance of tightening torques listed in above table: +10 %
Note: Lubricate stud with hydraulic oil before screwing in! *Thread M 27.0

⚠ Assembly in ports made of materials, which are strongly differing in strength and friction from steel, usually requires modified torques.

A reduction of torque is always required, when the turning angle from fingertight to the recommended torque is more than 30°!

In this case it is recommended to reduce the torque:

Port material	Hardness	Torque reduction by
Steel, with use of high performance lubrication (e.g. additive to hydraulic oil)	All	10 %
Ductile cast iron (e.g. GGG 50)	All	10 %
Aluminium	HB 150	15 %
	HB 125	20 %
	HB 100	30 %
	< HB 100	35 %

Port connections

Assembly of BSPP straight port connections



- BSPP Thread G
ISO 1179-1
DIN 3859-T2

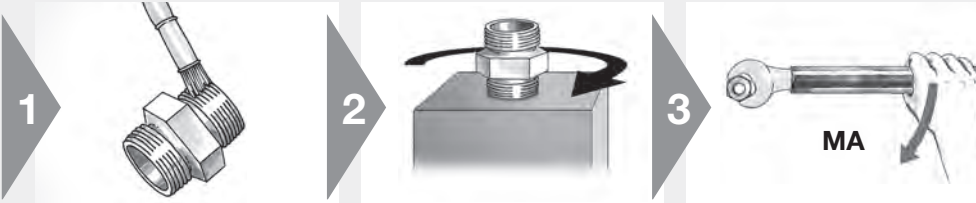

- ⚠ Threads of stainless steel fittings must be lubricated
- EO-NIROMONT is a special high-performance lubricant for stainless steel fittings
- Screw in until handtight
- Then tighten according to chart

Assembly torques for zinc plated steel fittings with BSPP thread in ports according to ISO 1179 made of steel

Product Series	Tube O.D.	Thread size T	Straight male stud fittings with port tapping				Non-return valves RHV/RHZ Form E with ED-sealing Nm	EO Banjo fittings			Adjustable ends ISO 1179-3 O-Ring and retaining-ring Nm	Blanking plugs oiled VSTI-ED Form E with ED-sealing Nm ⚠
			Form A for sealing washer Nm	Form B with cutting-face Nm	Form E with ED-sealing Nm	Form G with O-Ring and retaining ring Nm		WH/TH Nm	SWVE Nm	DSWW Nm		
EO L Triple-Lok®	6	G 1/8 A	9	18	18	18	18	18	20	25	18	13
	8	G 1/4 A	35	35	35	35	35	45	45	50	35	30
	10	G 1/4 A	35	35	35	35	35	45	45	50	35	(30)
	12	G 3/8 A	45	70	70	70	50	70	70	70	60	60
	15	G 1/2 A	55	140	90	90	85	120	100	110	90	80
	18	G 1/2 A	65	100	90	90	65	120	100	110	90	(80)
	22	G 3/4 A	90	180	180	180	140	230	140	185	180	140
	28	G 1 A	150	330	310	310	190	320		255	310	200
	35	G 1 1/4 A	240	540	450	450	360	540		315	450	400
	42	G 1 1/2 A	290	630	540	540	540	700		365	540	450
EO S O-Lok®	6	G 1/8 A	35	55	40		45	45	45	50	25	13
	6	G 1/4 A	35	55	40		45	45	45	50	40	30
	8	G 1/4 A	35	55	40		45	45	45	50	40	(30)
	10	G 3/8 A	45	90	80		60	70	70	70	60	60
	12	G 3/8 A	45	90	80		60	70	70	70	60	(60)
	14	G 1/2 A	65	150	115		145	120	100	110	90	80
	16	G 1/2 A	65	130	115		100	120	100	110	90	(80)
	20	G 3/4 A	90	270	180		145	230	145	185	180	140
	25	G 1 A	150	340	310		260	320		255	310	200
	30	G 1 1/4 A	240	540	450		360	540		315	450	400
38	G 1 1/2 A	290	700	540		540	700		365	540	450	

Tolerance of tightening torques listed in above table: +10 %
Note: Lubricate stud with hydraulic oil before screwing in.

⚠ Assembly in ports made of materials, which are strongly differing in strength and friction from steel, usually requires modified torques.

A reduction of torque is always required, when the turning angle from fingertight to the recommended torque is more than 30°!

In this case it is recommended to reduce the torque:

Port material	Hardness	Torque reduction by
Steel, with use of high performance lubrication (e.g. additive to hydraulic oil)	All	10 %
Ductile cast iron (e.g. GGG 50)	All	10 %
Aluminium	HB 150	15 %
	HB 125	20 %
	HB 100	30 %
	< HB 100	35 %

Port connections

Assembly of SAE straight port connections

- UN/UNF thread
ISO 11926-2/3

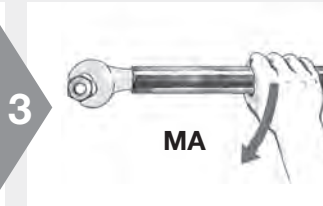
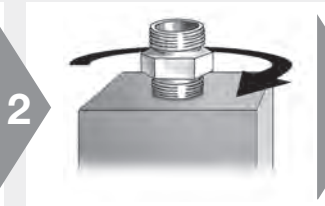
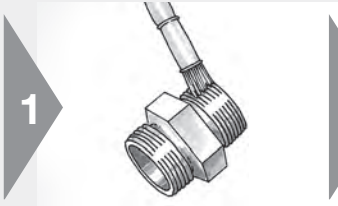
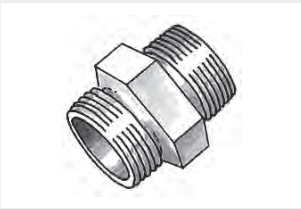

- ⚠ Threads of stainless steel fittings must be lubricated
- EO-NIROMONT is a special high-performance lubricant for stainless steel fittings

- Screw in until handtight

- Then tighten according to chart

Assembly torques for zinc plated steel fittings with UNF thread in ports according to ISO 11926 made of steel

Product	Thread size T ISO 11926	Series	
		EO / Triple-Lok® and O-Lok® Assembly torque non-adjustable end with O-ring sealing Nm	Assembly torque adjustable end with O-ring sealing Nm
Series	inch	Nm	Nm
EO L Triple-Lok®	7/16-20 UN(F)	23	18
	1/2-20 UN(F)	28	28
	9/16-18 UN(F)	34	34
	3/4-16 UN(F)	60	55
	7/8-14 UN(F)	115	80
	1 1/16-12 UN(F)	140	100
	1 5/16-12 UN(F)	210	150
	1 5/8-12 UN(F)	290	290
	1 7/8-12 UN(F)	325	325
EO S O-Lok®	7/16-20 UN(F)	35	20
	1/2-20 UN(F)	40	40
	9/16-18 UN(F)	46	46
	3/4-16 UN(F)	80	80
	7/8-14 UN(F)	135	135
	1 1/16-12 UN(F)	185	185
	1 5/16-12 UN(F)	270	270
	1 5/8-12 UN(F)	340	340
	1 7/8-12 UN(F)	415	415

Tolerance of tightening torques listed in above table: + 10 %
Note: Lubricate stud with hydraulic oil before screwing in!

- ⚠ Assembly in ports made of materials, which are strongly differing in strength and friction from steel, usually requires modified torques.

A reduction of torque is always required, when the turning angle from fingertight to the recommended torque is more than 30°!

In this case it is recommended to reduce the torque:

Port material	Hardness	Torque reduction by
Steel, with use of high performance lubrication (e.g. additive to hydraulic oil)	All	10 %
Ductile cast iron (e.g. GGG 50)	All	10 %
Aluminium	HB 150	15 %
	HB 125	20 %
	HB 100	30 %
	< HB 100	35 %

Port connections



Assembly of tapered thread port connections

- NPT / NPTF thread
ANSI / ASME B 1.20.1 – 1983

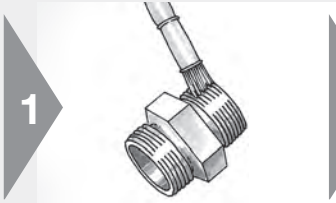

1

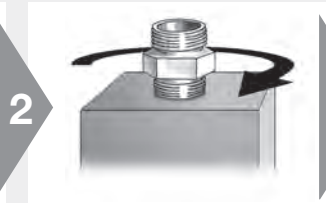

2



3

- ⚠ Threads of stainless steel fittings must be lubricated
- EO-NIROMONT is a special high-performance lubricant for stainless steel fittings

- Apply teflon tape (1.5 layer) to the taper stud end and screw in handtight

- Then tighten according to chart

Tightening of NPT / NPTF thread

Größe	Thread T NPT/F	Assembly TFFT Turns
4	1/8-27 NPT/F	2.0-3.0
6	1/4-18 NPT/F	2.0-3.0
8	3/8-18 NPT/F	2.0-3.0
10	1/2-14 NPT/F	2.0-3.0
12	3/4-14 NPT/F	2.0-3.0
16	1-11.5 NPT/F	1.5-2.5
20	1 1/4 -11.5 NPT/F	1.5-2.5
24	1 1/2-11.5 NPT/F	1.5-2.5

In the EO fitting range only **NPT** threads are manufactured.
In the **Triple-Lok®** and **O-Lok®** fitting range for **steel**
NPTF threads are used, and NPT for stainless steel components.estellt.

F

Adjustable fittings with locknut

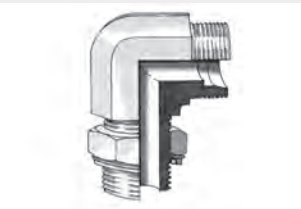

Assembly of the orientable joint

(EO: e.g. WEE, VEE, TEE, LEE - Triple-Lok® / O-Lok®: C4, V4, S4, R4)

⚠ Assembly steps must be done in right order

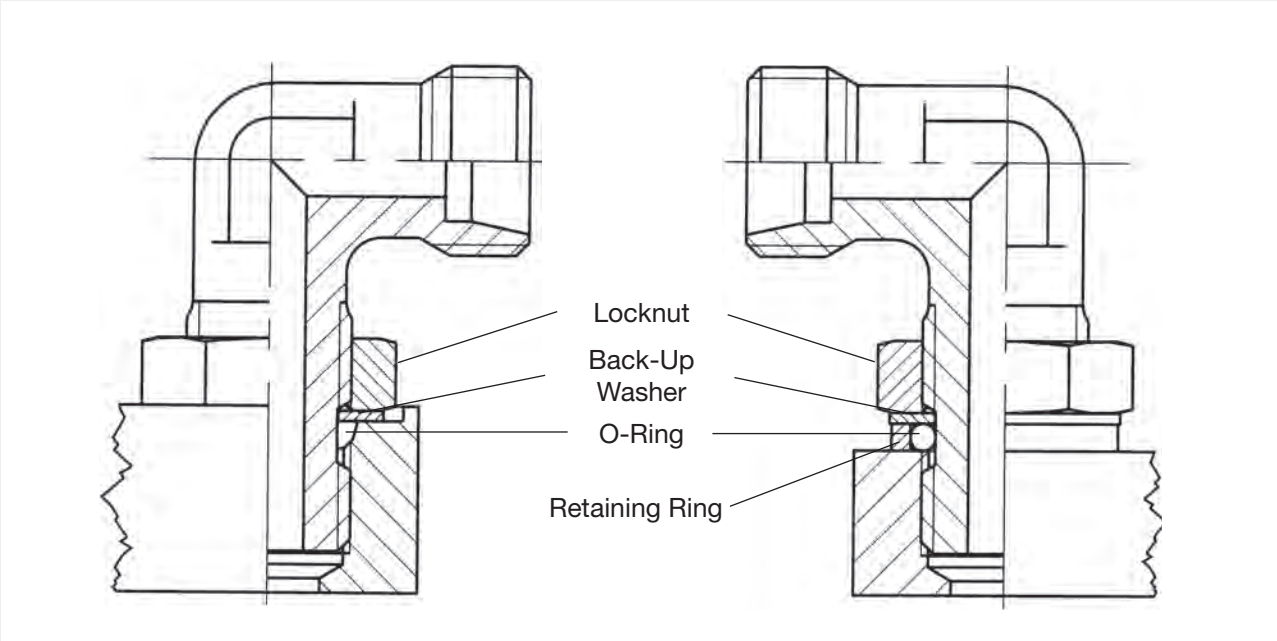

● Fitting *without* Retaining Ring for ISO 6149 or UN/UNF ports

● Fitting *with* Retaining Ring for BSPP or Metric Parallel ports with wide or SMALL spot faces

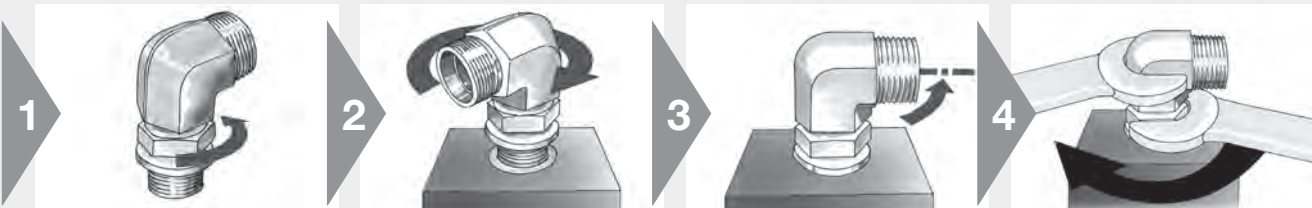

● Screw back locknut as far as possible

⚠ O-ring and back-up washer in the non-threaded section should be placed nearest to the locknut

● Lubricate the O-ring
● With BSPP and metric parallel version slip retaining ring over the O-ring



● Screw the fitting in the port by hand until retaining ring or back-up washers bottom



● To adjust direction, turn back to a maximum of one full turn

● Screw locknut handtight
● Assemble locknut until wrenchtight
● Hold body in desired position and tighten locknut



EO swivels

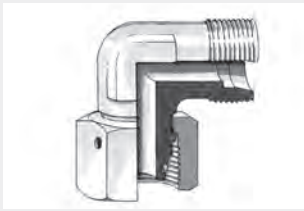

Assembly of EO swivel nut fittings

(e.g. EW, ET, EL, EGE, RED, VKA, SKA)

- Final assembly of swivel nut fittings must be made in appropriate fittings

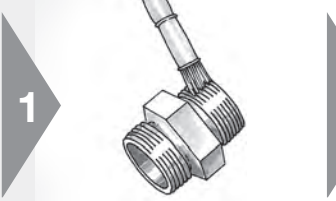

1

- ⚠ Threads of stainless steel fittings must be lubricated
- EO-NIROMONT is a special high-performance lubricant for stainless steel fittings



2

- Screw on nut by hand until handtight

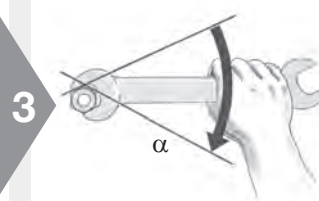

3

- ⚠ Then tighten fitting firmly by 1/4 turn (1 1/2 flats)

F

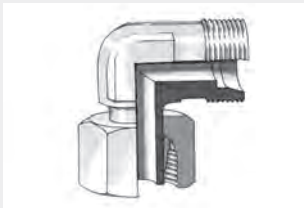

Final assembly of factory pre-assembled EO-standpipe fittings

(e.g. EVW, EVT, EVL, EVGE, KOR)

- For all fittings delivered pre-assembled from the factory the final assembly is performed in the appropriate fitting body

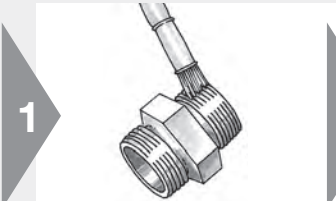

1

- ⚠ Threads of stainless steel fittings must be lubricated
- EO-NIROMONT is a special high-performance lubricant for stainless steel fittings

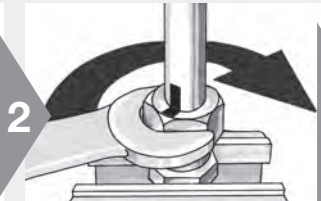

2

- Assemble fitting until wrench tight (without spanner extension)
- ⚠ Mark position of nut

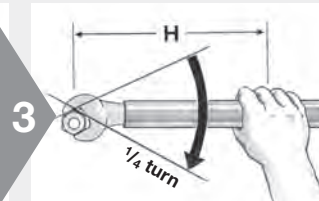

3

- ⚠ Then tighten fitting firmly by 1/4 turn (1 1/2 flats)
- ⚠ Recommended to use spanner extension for sizes over 20 mm O.D. (see chart)
- ⚠ The body must be hold rigid

Spanner length

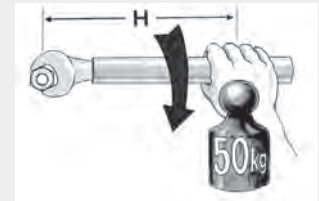

Size	Spanner length H [mm]
18-L 16-S	300
22-L 20-S	400
28-L 20-S	500
35-L 25-S	900
42-L 30-S	1200
38-S	1500

Triple-Lok® / O-Lok® swivels



Assembly of Triple-Lok® and O-Lok® swivel nut fittings

e.g.: Triple-Lok®: C6MX, V6MX, R6MX, S6MX, BBMTX
 O-Lok®: C6MLO, V6MLO, S6MLO, R6MLO, A0EL6

- Final assembly of swivel nut fittings must be made in appropriate fittings

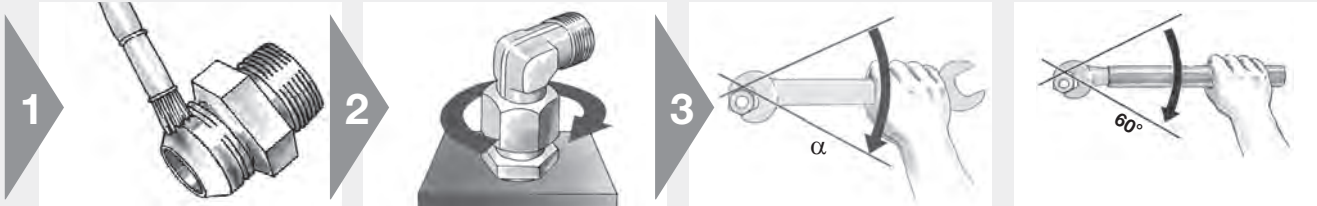

- ⚠ Threads of stainless steel fittings must be lubricated
- EO-NIROMONT is a special high-performance lubricant for stainless steel fittings

- Screw on nut by hand until handtight

- ⚠ Then tighten according to chart
- The body must be hold rigid

- one flat = 60°

Assembly torques for O-Lok® and Triple-Lok® swivel nut fittings

O-Lok®

Size	Metric tube mm	Inch tube inch	Thread UN/UNF	Nm ¹⁾	FFWR
4	6	1/4"	9/16-18	25	1/2
6	8	5/16"	11/16-16	40	1/2
6	10	5/16"	11/16-16	55	1/2
8	12	1/2"	13/16-16	55	1/2
10	14, 15, 16	5/8"	1-14	115	1/2
12	18, 20	3/4"	1 3/16-12	130	1/2
16	22, 25	1"	1 7/16-12	150	1/2
20	28, 30, 32	1 1/4"	1 11/16-12	190	1/2
24	35, 38	1 1/2"	2-12	245	1/2
32	50	2"	2 1/2-12	490	1/2

Triple-Lok®

Size	Metric tube mm	Inch tube inch	Thread UN/UNF	Nm ¹⁾	FFFT
4	6	1/4"	7/17-20	15	2
5	8	5/16"	1/2-20	20	2
6	10	3/8"	9/16-18	45	1 1/4
8	12	1/2"	3/4-16	60	1
10	14, 15, 16	5/8"	7/8-14	75	1
12	18, 20	3/4"	1 1/16-12	100	1
16	22, 25	7/8"	1 5/16-12	150	1
20	30, 32	1 1/4"	1 5/8-12	180	1
24	38	1 1/2"	1 7/8-12	200	1
28	42		2 1/4-12	220	1
32		2"	2 1/2-12	250	1

Assembly torques shown in chart are for **non-lubricated carbon steel zinc plated components**.
 For stainless steel fittings, lubricate all mating surfaces and tighten to upper end of torque tolerance.
 Recommended assembly torques are for connections consisting of all Parker manufactured components.

¹⁾ Tolerance of tightening torques max. +10 %

Flanges



Assembly of flanges

- SAE flange adapters
- SAE 4 bolt flanges
- Gear pump flanges
- ISO 6164 Square flanges

1



- Make sure sealing surfaces are free of burrs, nicks, scratches or any contamination
- Lubricate the O-ring with system fluid or compatible lubricant
- Parker recommends to lubricate the bolts on contact surface (head) and lower third of thread (MOLYKOTE G-RAPID PLUS) just before use to avoid any contamination

2



- Position flange or flange adapter with clamp halves
- Placement of the spring washer on the bolt and connect both to the flange (only for gear pump flanges)

3

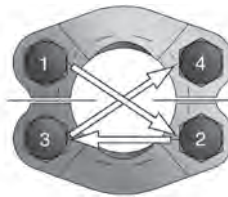

- Hand tighten bolts
- Torque bolts in diagonal sequence in small increments to the appropriate torque level listed in chart

4

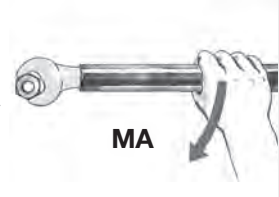

- Tighten bolts according to chart

Torques for bolts, see page N8!

F

Replacement of an EO Bite type connection

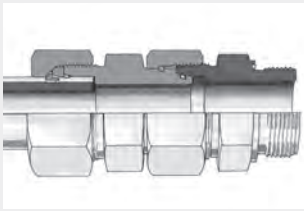

Distance piece adapter DA

- EO distance piece adapters allow replacement of bite type connections on existing pipework easily or retrofitting using EO-2
- The existing tubes can be re-used

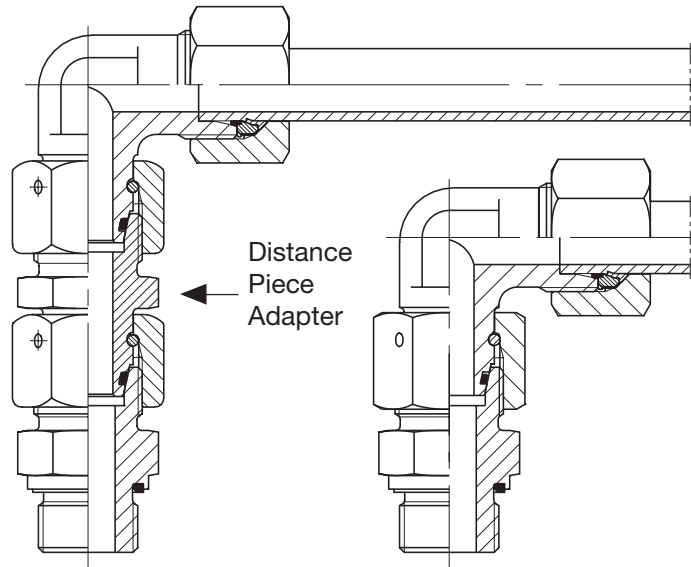

- Use as an extension for stacked assemblies

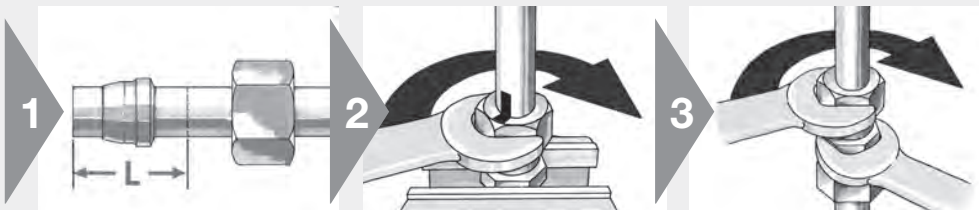

- Cut length L off tube-end (see "DA" chapter I)
- Scrap obsolete nut

- Assemble new EO-2 functional nut or EO PSR/DPR and nut

- Thread on
 - Then tighten distance piece adapter onto tube-end
- ⚠ The body must be hold rigid

Tube bending

Instructions for EO hand-bending equipment

- For on-site piping jobs
- Not for mass production

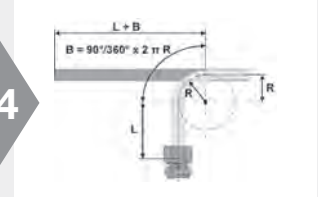
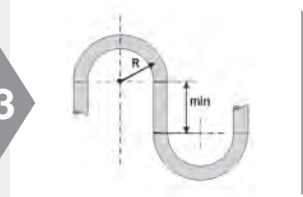
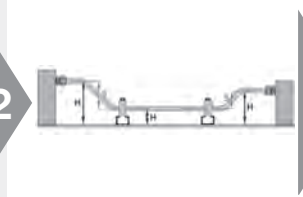

- ⚠ Think the whole process through and plan each individual step before starting
- ⚠ First bend and then cut ends to length
- Gather all dimensions like minimum straight lengths, extra length for flaring, bending radius, tube lengths for bows, etc.

- Consider steps
- Plan for clamping

- Check bending equipment specifications for limitations

- Start with first elbow
- Leave tube-end longer if in doubt

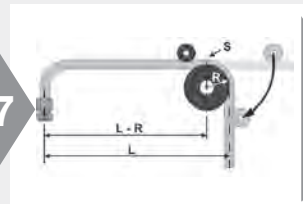
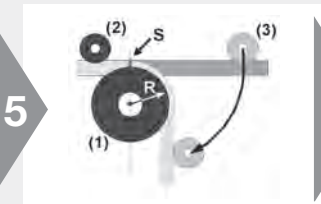

- ⚠ Mark start of bend on tube (S)
- Adjust tube between bending roll (1), clamping roll (2) and pressure roll (3)
- Bend tube by pulling lever

- Check bend angle
- Correct angle if necessary
- Gather all dimensions for next bending operation

- ⚠ Mark start of bend on tube
- Continue bending
- Check and correct each result before starting next bend

- After the last bend, check tube for angles and dimensions
- Now cut both tube-ends to correct length
- Make sure that tube fits without tension

F

Tube line fabrication guide for leak free systems

Every hydraulic, pneumatic and lubrication system requires some form of tube fabrication and fitting installation for completion. Proper fabrication and installation are essential for the overall efficiency, leak free performance, and general appearance of any system.

After sizing the tube lines and selecting the appropriate style of fitting, consider the following in the design of your system:

1. Accessibility of joints
2. Proper routing of lines
3. Adequate tube line supports
4. Available fabricating tools

- Keep tube lines away from components that require regular maintenance:

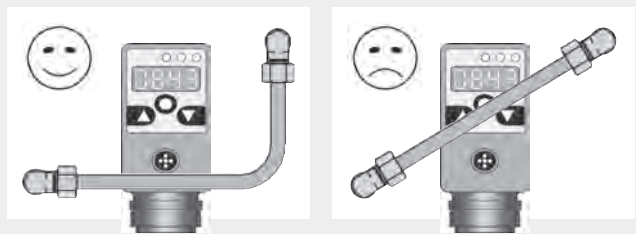

- Right-angled – parallel – clear
- Have a neat appearance and allow for easy trouble-shooting, maintenance and repair:

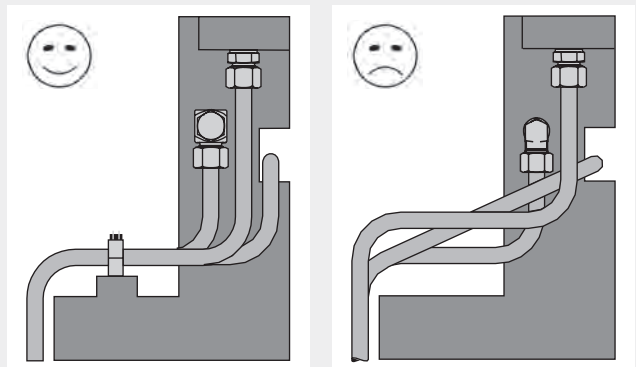

- Example for tube to hose connection:

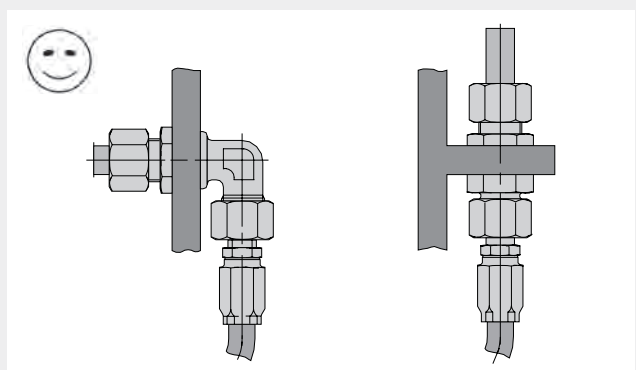

Tube line fabrication guide for leak free systems

- Do not use tube lines to support other tubes
- Always fix tubes onto a rigid point with tube clamps
- Do not use cable channels to support tubes

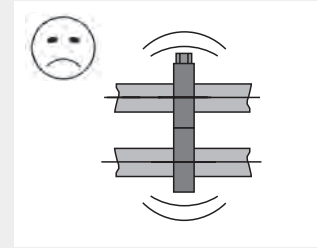
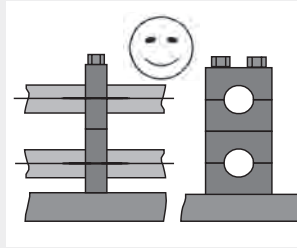

- Use appropriate tube clamps:

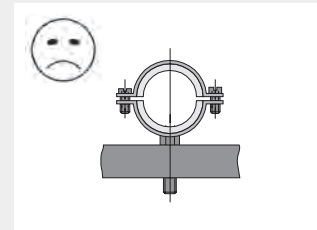
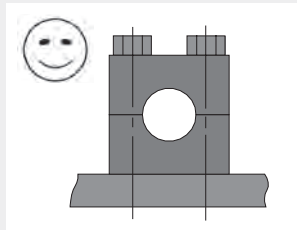

- Avoid excessive strain on joint:
A strained joint will eventually leak

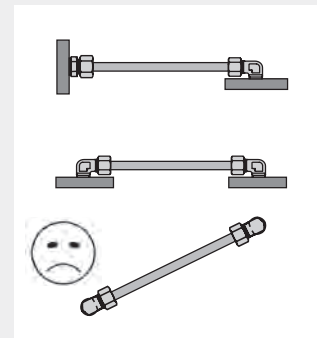
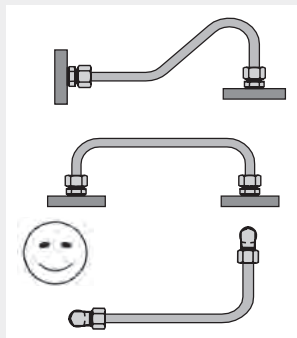

- Allow for expansion effects

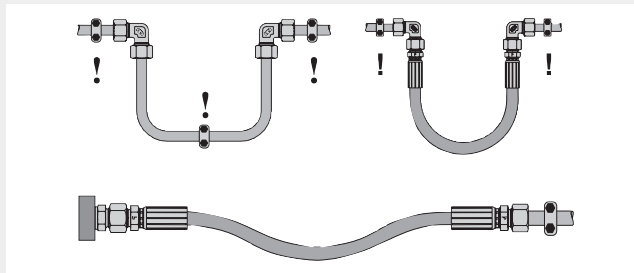

- Avoid short tube length:
⚠ Short tube lengths increase chance of fatigue fractures
- Use adapter GZR or swivel connector for swivel fittings instead of short tube lengths

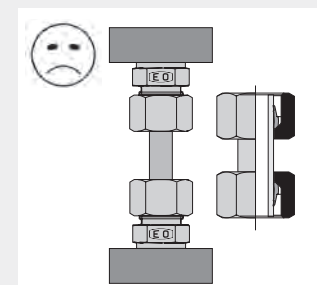
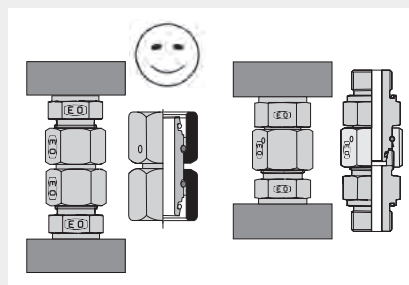

F

Tube line fabrication guide for leak free systems

- Support against actuating forces:

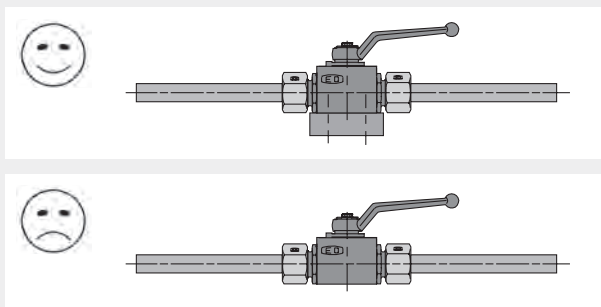

Recommended tools for tube line fabrication:

Cutting:

EO Tube cutting tool AV

EO Combined tube bending and cutting tool BAV

Tube cutters:

Steel: Type Kloskut;

Stainless Steel: Type 635 B-EX,

Type 218 B-SS Tru-Kut Sawing Vice

Deburring:

Parker deburring tool no. 226 DEBURR

Bending:

EO Combined tube bending and cutting tool BAV

EO Tube bending tool BV 6/18, BV 20/25

EO Tube bending tool BVP (programmable)

Tube lines have to be supported in certain distances:

Use sufficient tube clamps to support weight

Use sufficient tube clamps to protect joints from vibration

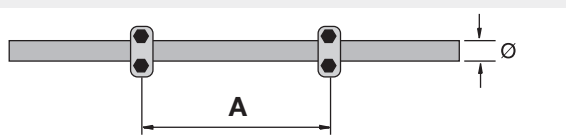

Ø [mm]	A [m]
6.0 – 12.7	1.0
12.7 – 22.0	1.2
22.0 – 32.0	1.5
32.0 – 38.0	2.0
38.0 – 57.0	2.7
57.0 – 75.0	3.0
75.0 – 76.1	3.5
76.1 – 88.9	3.7
88.9 – 102.0	4.0
102.0 – 114.0	4.5
114.0 – 168.0	5.0
168.0 – 219.0	6.0
219.0 – 324.0	6.7
324.0 – 356.0	7.0
356.0 – 406.0	7.5

The clamp pitches corresponding to respective outside pipe diameters are standard for static loads.

Vibration has to be eliminated near by the connectors:

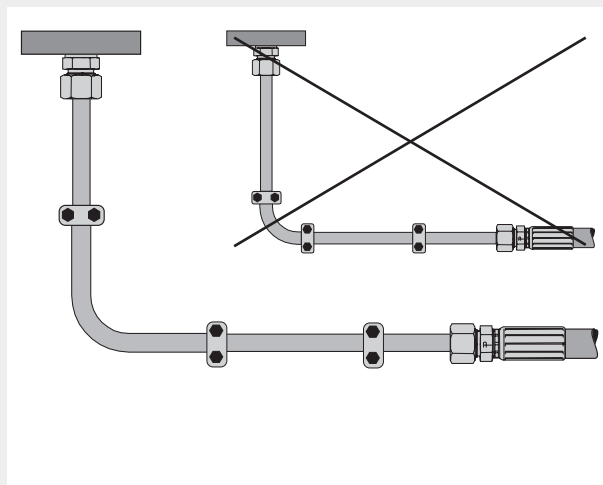

Allow expansion and contraction. Do not hamper expansion and contraction near by tube bends.

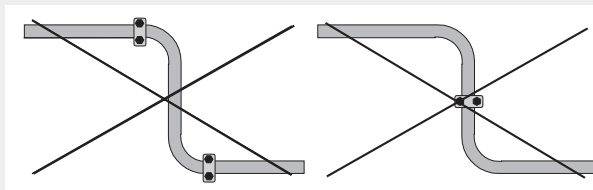
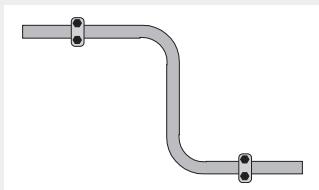



Trouble shooting guide

Trouble shooting

DPR/PSR Problem	Probable cause	Suggested solution
Leak	Insufficiently tightened, shallow bite	Tighten the nut according to correct number of turns, direct assembly only for maintenance/repair
		Use correct spanners and spanner extensions especially for larger sizes and stainless steel fittings, use of recommended pre-assembly machines
		Mark nut and body to indicate correct assembly
		Use recommended lubrication
		Use of pre-assembly machines e.g. EO-KARRYMAT, EOMAT ECO, EOMAT UNI
		Pre-assemble joints away from installation to ensure proper bite
		Check visible collar
	Tube not bottomed into fitting shoulder	Cut tube to correct length
		Observe min. straight length before tube bend
		Use hacksaw and guide not a plumbing – style tube cutter
		Carefully deburr tube end – no heavy chamfers
		Push tube firmly into cone
		Check visible collar
	Damaged fitting	Check for damage, replace damaged parts
		Handle all components carefully
	Contamination between sealing surfaces	Keep all components clean
	Hidden crack	Check for cracks, replace if necessary
	Mismatch of components	Select all components according to system application and product specification
		Use genuine Parker components
	Phantom leak, from assembly lubricant	Carefully identify proper source of leak
Don't over use lubricant		
Tube fractured behind the nut	Fatigue failure of tube under vibration	Review final tightening process, undertightening reduces vibration resistance
		Stress free installation
		Proper use of clamps
		Bulkhead connection and hose to isolate joints from vibration
		Make sure that operating conditions (pressure, corrosion, temperature, pressure peaks ...) do not exceed fitting performance
Crack	Insufficiently tightened, shallow bite	Tighten the nut according to correct number of turns
		Use correct spanners and spanner extensions especially for larger sizes and stainless steel fittings
		Mark nut and body to indicate correct assembly
		Use recommended lubrication
		Pre-assemble joints away from installation to ensure proper bite
		Check visible collar

DPR/PSR Problem	Probable cause	Suggested solution
Crack	Severe working conditions	Make sure that operating conditions (pressure, corrosion, temperature, pressure peaks, ...) do not exceed fitting performance
Tube blow out	Standpipe fitting, improper final assembly	Use swivel nut fitting
	Cold welded threads on stainless steel fittings	Use "EODUR" stainless steel fittings from Parker (with silver plated nut threads) and always lubricate threads with EO NiroMont fluid (not hydraulic oil)
	Use of worn or unsuitable pre-assembly tools	Check tools regularly and replace worn tools
		Keep tooling clean and oiled plus check cone regularly with "KONU" cone templates every 50 assemblies
	Tube not bottomed into fitting shoulder	Cut tube to correct length
		Observe min. straight length before tube bend
		Use hacksaw and guide not a plumbing – style tube cutter
		Carefully deburr tube end – no heavy chamfers
	Severe working conditions	Push tube firmly into cone
		Check visible collar
		Make sure that operating conditions (pressure, corrosion, temperature, pressure peaks, flow rate, ...) do not exceed fitting performance
	Ring installed in wrong direction	Check visible collar
		Install ring in proper orientation
Use pre-assembled fitting or EO-2		
Steel ring used on stainless steel tube	Always check assembly before final installation	
	Use stainless steel bite rings for stainless steel tube, preassembly necessary	
Stainless steel fitting not pre-assembled	Pre-assemble joint away from installation	
	Use specified preassembly tools/machines	
Fitting body used as preassembly tool	Use specified preassembly tools, machine preset preferred	
Short tube end fracture	Fatigue failure	Use swivel nut adapter (GZ ...)

EO-2 Problem	Probable cause	Suggested solution
Leak	Insufficiently tightened, shallow bite	Use of pre-assembly machines e.g. EO-KARRYMAT, EOMAT ECO, EOMAT UNI
		Insufficiently tightened
	Insufficiently tightened	Use correct spanners and spanner extensions especially for larger sizes and stainless steel fittings
		Use recommended lubrication
		Pre-assemble joints away from installation to ensure proper bite
		Use original EO pre-assembly tools
Tube not bottomed into fitting shoulder	Check closed gap	
	Cut tube to correct length	
	Observe min. straight length before tube bend	



Trouble shooting

EO-2 Problem	Probable cause	Suggested solution
Leak	Tube not bottomed into fitting shoulder	Use hacksaw and guide not a plumbing – style tube cutter
		Use EO-2 MOK for big sizes
		Carefully deburr tube end – no heavy chamfers
		Push tube firmly into cone
	Damaged fitting	Check for damage
		Handle all components carefully
	Damage to fitting cone	Make sure tube is bottomed at assembly
	Contamination between sealing surfaces	Keep all components clean
	Hidden crack	Check for cracks, replace if necessary
	Mismatch of components	Select all components) according to system application and product specification
Use genuine Parker components		
Phantom leak from assembly lubricant	Carefully identify proper source of leak	
	Don't over use lubricant	
Sealing ring (DOZ) missing	Use plugs for transport of preassembled tubes. Check assembly before final installation	
Tube fractured behind the nut	Fatigue failure of tube under vibration	Stress free installation
		Proper use of clamps
		Bulkhead connection and hose to isolate joints from vibration
Severe working conditions	Make sure that operating conditions (pressure, corrosion, temperature, pressure peaks ...) do not exceed fitting performance	
Crack	Insufficiently tightened	Use correct spanners and spanner extensions especially for larger sizes and stainless steel fittings
		Use recommended lubrication
		Pre-assemble joints away from installation to ensure proper bite
		Use original EO preassembly tools
		Check closed gap
Tube blow out	Cold welded threads on stainless steel fittings	Use "EODUR" stainless fittings from Parker (with silver plated nut threads) and always lubricate threads with EO Niromont fluid (not hydraulic oil)
	Tube not bottomed into fitting shoulder	Cut tube to correct length
		Observe min. straight length before tube bend
		Use hacksaw and guide not a plumbing – style tube cutter
		Carefully deburr tube end – no heavy chamfers
		Push tube firmly into cone
		Use EO-2 MOK for big sizes
	Severe working conditions	Make sure that operating conditions (pressure, corrosion, temperature, pressure peaks, flow rate ...) do not exceed fitting performance
	Fitting undertightened	Tighten the nut until cap between retaining and sealing ring is closed
		Use correct spanners and spanner extensions especially for larger sizes and stainless steel fittings

EO-2 Problem	Probable cause	Suggested solution
Tube blow out	Fitting undertightened	Mark nut and body to indicate correct assembly
		Use recommended lubrication
		Pre-assemble joints away from installation to assure proper bite
	FM ... steel is used	Use exclusively FM stainless steel with stainless steel on stainless steel tube, for combination of steel fitting/ stainless steel tube use FM ... SSA nut
Short tube end fracture	Fatigue failure	Use swivel nut adapter (GZ...)

EO-2-FORM Problem	Probable cause	Suggested solution
Leak	Insufficiently tightened, shallow bite	Use correct spanners and spanner extensions especially for larger sizes and stainless steel fittings
	Damaged fitting	Check for damage
		Handle all components carefully
	Damage of fitting cone	Make sure tube is bottomed at assembly
	Contamination between sealing surfaces	Keep all components clean
	Hidden crack	Check for cracks, replace if necessary
	Mismatch of components	Select all components according to system application and product specification
		Use genuine Parker components
	Phantom leak from assembly lubricant	Carefully identify proper source of leak
		Don't over use lubricant
Sealing ring (DOZ) missing	Use plugs for transport of preassembled tubes. Check assembly before final installation	
Incorrect tube forming	Check assembly before installation	
	Use correct tool according to tube diameter, wall thickness and material	
	Regularly check tools for wear and damage	
	Replace damaged tooling	
	Use specified lubricant LUBSS on forming process	
Misalignment	Stress free installation. Flanged tube end needs contact to stud ends before final tightening. Check length and bends of tubing to ensure this	
Crack	Fatigue failure of tube under vibration	Stress free installation
		Proper use of clamps
		Bulkhead connection and hose to isolate joints from vibration
	Severe working conditions	Make sure that operating conditions (pressure, corrosion, temperature, pressure peaks...) do not exceed fitting performance



Trouble shooting

O-Lok® Problem	Probable cause	Suggested solution	
Leak	Damaged Trap-Seal	Hold sealing surfaces together until nut is firmly tightened	
	Missing Trap-Seal	Use genuine Parker O-Lok® fittings with Trap-Seal groove (CORG)	
	Extruded Trap-Seal		Ensure proper alignment
			Tightened to proper torque
			Use genuine Parker O-Lok® fittings with Trap-Seal groove (CORG)
	Pinched Trap-Seal due to air bleeding	Use bleed valves (PNLOBA/FNLBA) or test points EMA and hose for bleeding	
	Phantom leak from assembly lubricant		Carefully identify proper source of leak
			Don't over use lubricant
	Uvertightening	Use correct spanners and spanner extensions especially for larger sizes and stainless steel fittings. Use recommended torque or FFFT method	
	Damaged fitting		Check for damage
		Handle all components carefully	
Poor surface quality of flange		Spiral marks can be avoided by proper deburring of tubes, particular the tube I.D.	
		Clean tools, remove metal particles from pin	
Hidden crack		Check for cracks, replace if necessary	
Tube fractured behind the nut	Fatigue failure of tube under vibration	Stress free installation	
		Proper use of clamps	
		Bulkhead connection and hose to isolate joints from vibration	
Severe working conditions	Make sure that operating conditions (pressure, corrosion, temperature, pressure peaks ...) do not exceed fitting performance		
Crack	Fatigue failure of tube under vibration	Stress free installation	
		Proper use of clamps	
		Bulkhead connection and hose to isolate joints from vibration	
	Severe working conditions	Make sure that operating conditions (pressure, corrosion, temperature, pressure peaks ...) do not exceed fitting performance	

Triple-Lok® Problem	Probable cause	Suggested solution
Leak	Damaged fitting	Check for damage
		Handle all components carefully
	Contamination between sealing surfaces	Keep all components clean
	Hidden crack	Check for cracks, replace if necessary
	Mismatch of components	Select all components according to system application and product specification
		Use genuine Parker components
	Phantom leak from assembly lubricant	Carefully identify proper source of leak
Don't over use lubricant		

Triple-Lok® Problem	Probable cause	Suggested solution
Leak	Undertightening	Use correct spanners and spanner extensions especially for larger sizes and stainless steel fittings. Use recommended torque or FFFT method
	Scratches in Tube ID and flare area	Use Parflange process to improve surface quality
Tube fractured behind the nut	Fatigue failure of tube under vibration	Stress free installation
		Proper use of clamps
		Bulkhead connection and hose to isolate joints from vibration
Crack	Fatigue failure of tube under vibration	Stress free installation
		Proper use of clamps
		Bulkhead connection and hose to isolate joints from vibration
	Severe working conditions	Make sure that operating conditions (pressure, corrosion, temperature, pressure peaks ...) do not exceed fitting performance



Weld nipples Problem	Probable cause	Suggested solution
Leak	Misalignment	Stress free installation
		Fix weld nipple to tube in application before finishing the welding
	Damaged O-ring	Inspect O-ring before final installation. Make sure that O-ring is not twisted at installation lubricate O-ring
	Missing O-ring	Assemble proper O-ring
	Extruded O-ring	Ensure proper alignment
	Pinched O-ring due to air bleeding	Use bleed valves (PNLOBA/FNLBA) or test points EMA and hose for bleeding
	Phantom leak from assembly lubricant	Carefully identify proper source of leak
		Don't over use lubricant
Undertightening	Use correct spanners and spanner extensions especially for larger sizes and stainless steel fittings	
Damaged fitting	Check for damage	
	Handle all components carefully	
Tube fractured behind the nut	Fatigue failure of tube under vibration	Stress free installation
		Proper use of clamps
		Bulkhead connection and hose to isolate joints from vibration
	Severe working conditions	Make sure that operating conditions (pressure, corrosion, temperature, pressure peaks ...) do not exceed fitting performance
Crack	Fatigue failure of tube under vibration	Stress free installation
		Proper use of clamps
		Bulkhead connection and hose to isolate joints from vibration
	Severe working conditions	Make sure that operating conditions (pressure, corrosion, temperature, pressure peaks ...) do not exceed fitting performance

Trouble shooting

Flanges connection			
Problem	Probable cause	Suggested solution	
Leak	Misalignment	Stress free installation	
	Damaged O-ring	Inspect O-ring before final installation. Make sure that O-ring is not twisted at installation lubricate O-ring	
	Missing O-ring	Assemble proper O-ring	
	Extruded O-ring		Ensure proper alignment
			Tightened bolts to recommended torque
	Pinched O-ring due to air bleeding	Use bleed valves (PNLOBA/FNLBA) or test points EMA and hose for bleeding	
	Phantom leak from assembly lubricant		Carefully identify proper source of leak
			Don't over use lubricant
	Undertightening	Use correct spanners and spanner extensions especially for larger sizes and stainless steel fittings	
Unequal tightening	For flanges with more than 2 screws: see assembly instruction in what order the screws need to be tightened		
Damaged fitting		Check for damage	
		Handle all components carefully	
Tube fractured behind the nut	Fatigue failure of tube under vibration	Stress free installation	
		Proper use of clamps	
		Bulkhead connection and hose to isolate joints from vibration	
	Severe working conditions	Make sure that operating conditions (pressure, corrosion, temperature, pressure peaks ...) do not exceed fitting performance	
Crack	Fatigue failure of tube under vibration	Stress free installation	
		Proper use of clamps	
		Bulkhead connection and hose to isolate joints from vibration	
		Severe working conditions	Make sure that operating conditions (pressure, corrosion, temperature, pressure peaks ...) do not exceed fitting performance

Leaks from ports			
Problem	Probable cause	Suggested solution	
Leak	O-ring sealing is missing/damaged	Replace with new O-ring	
	Fitting not tightened properly, Undertightening		Retighten to appropriate specification
			Use correct spanners and spanner extensions especially for larger sizes and stainless steel fittings
	Undertightened at initial assembly		Use recommended lubrication
			Repeat with appropriate assembly torque
	Adjustable stud not assembled properly		Proper assembly procedure
	O-ring pinched		Redesign system
	Fitting vibrates loose		Clamping/Check the assembly torque
			Stressed joints
Threads damaged		Replace fitting	
Use of tapered threads (NPT/BSPT/+++)		Use fittings with soft sealing O-ring/ED sealing	

Leaks from ports Problem	Probable cause	Suggested solution
Leak	Port stud end Form B	Sealing edge Form B is damaged replace fitting
	Sealing surface is damaged	Rework sealing surface
Fitting vibrates loose	Undertightened at initial assembly	Tighten the nut according to correct torque Use correct spanners and spanner extensions especially for larger sizes and stainless steel fittings
	Torsion forces on assembly	Use clamps or bulkhead fittings to isolate twisting hose
		Avoid stress at initial assembly
Fractured stud	Severe overtightening	Do not exceed specified tightening instructions
	Fatigue failure of tube under vibration	Stress free installation
		Proper use of clamps
		Bulkhead connection and hose to isolate joints from vibration
Severe working conditions	Make sure that operating conditions (pressure, corrosion, temperature, pressure peaks...) do not exceed fitting performance	



Triple-Lok® 1025/50 Problem	Probable cause	Suggested solution
Tube slips in die during flanging or flaring	Tube undersized	Use tube within tolerance
	Die grip surface dirty	Clean with solvent
	Die grip surface worn	(do not use any wire brush) Replace Die
Flange/flare diameter too small	Tube slipped in die	See problem "Tube slips in die..."
	Incorrect pin	Use correct pin for tube size
	Die needs adjustment/incorrect die.	Contact Parker Rep./Use correct die
	Tube was not inserted to tube stop	Insert tube to tube stop
Flange/flare diameter too large	Tube forced against tube stop	Do not force tube against tube stop
	Die needs adjustment/incorrect die	Contact Parker Rep./Use correct die
	Incorrect pin and/or tube wall	Use correct pin for tube size
Flange/flare out of round	Tube not cut squarely	Cut tube squarely, within $\pm 1^\circ$
	Tube not supported properly	Support tube in line with dies
	Obstruction in die holder	Clean and remove debris
	Tube wall thickness varies	Use good quality tube
	Incorrect pin and/or tube wall	Use correct pin for tube size
Cracked flange/flare	Poor tube quality	Use recommended quality tube
	Too hard tube	Use recommended quality tube
	Heavy chatter during deburring	Eliminate chatter in deburring
Scored, pitted flange/ flare surface	Improper/lack of lubrication on pin	Use recommended lubricant
	Tube not properly deburred	Deburr and remove filings
	Tube not properly cleaned	Clean to remove filings
	Pin not cleaned	Keep pin clean but lubricated

Trouble shooting

O-Lok® 1025/50 Problem	Probable cause	Suggested solution
Flange/flare diameter too large	Tube forced against tube stop	Do not force tube against Tube stop
	Die needs adjustment/	Contact Parker
	Incorrect die	Use correct die
	Incorrect pin and/or tube wall	Use correct pin for tube size
	Sleeve not located properly in die	Locate sleeve in die cavity correctly
Flange/flare not round	Tube not cut squarely	Cut tube squarely, within $\pm 1^\circ$
	Tube not supported properly	Support tube in line with dies
	Obstruction in die holder	Clean and remove debris
	Tube wall thickness varies	Use good quality tube
	Incorrect pin and/or tube wall	Use correct pin for tube size
Cracked flange/flare	Poor tube quality	Use recommended quality tube
	Tube too hard	Use recommended quality tube
	Heavy chatter during deburring	Eliminate chatter in deburring
Scored, pitted flange/flare surface	Improper/lack of lubrication on pin	Use recommended lubricant
	Tube not properly deburred	Deburr tube and remove filings
	Tube not properly cleaned	Clean tube to remove filings
	Pin not cleaned	Keep pin clean and lubricated
Flange pin breaks during flanging	Incorrect pin and/or tube wall/ or wrong pin for tube material	Use correct pin for tube size/material













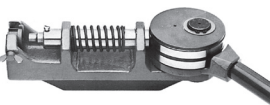

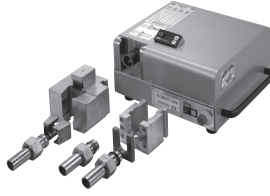

Assembly tooling

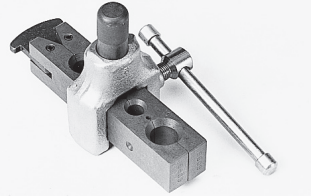
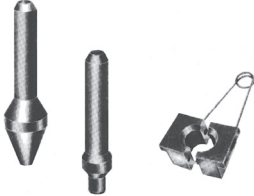















Assembly tooling

Index

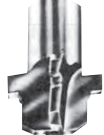
<p>Manual assembly tools for EO/EO-2</p>	 <p>VOMO p. H5</p>	 <p>KONU p. H6</p>	 <p>AKL p. H7</p>
<p>Manual assembly devices</p>	 <p>HVM-B p. H9</p>	 <p>EO-KARRYMAT p. H11</p>	
<p>Assembly machines for EO/EO-2, Triple-Lok®</p>	 <p>EOMAT ECO p. H13</p>	 <p>EOMAT UNI p. H15</p>	 <p>EOMAT PRO p. H21</p>
<p>Forming machines for EO2-FORM, EO-3®</p>	 <p>EO2-FORM F3 p. H24</p>	 <p>EO2-FORM PRO22 p. H24</p>	 <p>EO-KARRYFORM p. H25</p>
<p>Flaring tools for Triple-Lok®</p>	 <p>1004 p. H32</p>	 <p>Impact flarer p. H33</p>	 <p>KARRYFLARE p. H34</p>
<p>Parflange® Machines for O-Lok®/Triple-Lok®</p>	 <p>Parflare ECO p. H35</p>	 <p>Parflange® 1025 p. H39</p>	 <p>Parflange® 50 p. H41</p>
		 <p>Parflange® 50 PRO p. H43</p>	

Index

<p>Lubricants</p>	 <p>EO-NIROMONT p. H49</p>	 <p>LUBSS p. H49</p>	
<p>Cutting, bending and deburring tools</p>	 <p>AV 6/42 p. H50</p>	 <p>BAV 6/12 p. H51</p>	 <p>IN-EX 226 p. H51</p>
<p>Tube bending tools</p>	 <p>BV 6/18 p. H52</p>	 <p>BV 20/25 p. H53</p>	
<p>Hand-tools</p>	 <p>Par-Lok wrench p. H54</p>	 <p>WZK - Tool box p. H55</p>	
<p>O-Ring assembly tools for O-Lok®</p>	 <p>O-Lok® CORG p. H56</p>	 <p>O-Ring Pick p. H56</p>	
<p>Port manufacturing tools</p>	 <p>Counterbore p. H57</p>	 <p>Thread taps p. H57</p>	
<p>Thread identification</p>	 <p>Thread ID kit p. H59</p>	 <p>Portboard p. H59</p>	 <p>Sample case p. H60</p>



Parker tube fabricating equipment

Equipment described in this section is designed to make strong, accurate tubing systems easier and more dependable. Every time you make up a tubing circuit, you want to be sure you get strong dependable joints, accurate kink-free bends and a neat system that will stand up to years of hard service. You want to fabricate the system with the least effort and risk of errors.

Parker tube fabricating equipment is designed to help you get all these benefits. Parker has been leading the way in use of tubing and in fittings design for over 60 years. All this experience has shown Parker engineers a host of ways to make tube fabricating equipment more efficient and trouble free. You'll find them all in the equipment featured here – from improvements that help you make accurate concentric flares, to bender designs that make kink-free bending easier. They'll all help you get better tubing systems with less work and less risk of mistakes in fabrication.

Machine selection

Parker offers a variety of assembly devices and machines for different products and different applications. Refer to overview in chapter E for machine recommendation.

Disposal of old equipment

The HPCE electrically driven assembly machines are large stationary industrial tools within the meaning of the Electrical and Electronic Equipment Act (EC Directive 2002/96/EC/“WEEE Directive”). This equipment is not usually used in private households but in industry. Within the scope of the Electrical Act, industrial users are responsible for the professional disposal of old equipment.

Service

Assembly machines and standard tooling for HPCE connectors are available from stock for immediate service. Both purchasing and leasing are possible depending on machine type and volume of business. For limited projects, assembly equipment can be provided on a rental basis via our certified distributor network. Special “demo”-equipment is available for sales presentations and fairs.

Technical support

HPCE machine service procedures ensure that reliable machine function and fitting performance is achieved when using genuine Parker assembly equipment. All machines come with detailed operating manuals. Parker distributors and sales representatives are trained to give advice on operation and application. Experienced application engineers at HPCE are available when it comes to special application of HPCE assembly equipment. In case of machine malfunction, spare machines can be provided on short notice so that production can continue. In the meantime, damaged machinery is checked and repaired at the HPCE machine repair facility. Well trained and experienced engineers take personal care that the

machines return properly repaired and tested. HPCE also offers a machine maintenance and calibration service. Standard spare parts like oil filters can be ordered from stock.

Repair procedure

Please contact your Parker Service Center for problem solving/repair. Your correspondent will organise the repair and arrange a spare machine if required. Please do not send in machines without notice to your sales correspondent. To assure optimum service, all machine shipments must include a documentation with information about: Machine type, serial number, purchase data, problem description, contact name, phone number and complete address for return.



Experienced engineers support proper operation of HPCE assembly machinery

Tool lifetime

Assembly tools are subject of wear and must be regularly (max. 50 assemblies) cleaned and checked (Checking instructions see chapter E). Worn out tools can cause dangerous assembly failures and must be replaced in time. Maximum lifetime can be achieved by following factors:

- Regular cleaning and checking
- Clean and corrosion-protected storage
- Proper de-burring and cleaning of tube end
- Proper tool selection and operation
- Use of specified lubricant

Manual assembly tools for EO/EO-2

VOMO – Pre-assembly tools for EO/EO-2 tube connections

Simple but essential tool for the manual presetting of EO-fittings. The use of a VOMO assures that the bite ring securely cuts into the tube without damage on the inner fitting cone.

Pre-assembly using VOMO or EOMAT must be done for all connections of:

- EO-2 with large tube dimensions (Tube O.D. 30 mm and above)
- EO-Progressive Stop Ring/Progressive Ring with stainless steel tube or standpipe fittings (E.g.: "BE"-type hose fitting).

For proper use, see EO assembly instructions. VOMO tools wear out and then may cause assembly failures. VOMO's must be checked regularly with "KONU" cone-templates (max. after 50 assemblies) and replaced when damaged or worn out.

Specifications:

Material: hardened tool steel
 Sizes: 4 LL – 12 LL,
 6 L – 42 L,
 6 S – 38 S

Pre-assembly of: EO-2 and Progressive Stop Ring PSR/EO progressive Ring DPR

Economic production qty: Max. 10 assemblies per day.

Features, advantages and benefits of pre-assembly tools:

1. **Marking notch** – A special ridge engraves a circular mark onto the tube end to verify that it was properly bottomed at assembly. Failures caused by improper tube cutting or bottoming in VOMO can be recognised before final installation.
2. **Flexible** – A VOMO can be used anywhere to assure safe fitting assembly – even at assembly sites where EOMAT machines are not available.
3. **Safe** – Hazardous blowout of incorrect assembled standpipe hose fittings or stainless steel tube can be avoided by VOMO-assembly.



4. **Efficient** – There is no doubt that VOMO-presetting contributes to save time and effort in bite-type assembly. The small investment pays back immediately.
5. **Special** – VOMO tools are specifically designed and manufactured to match EO-fitting standards.
6. **Tool lifetime** – Assembly tools are subject of wear and must be regularly (max. 50 assemblies) cleaned and checked (Checking instructions see chapter E). Worn out tools can cause dangerous

assembly failures and must be replaced in time. Maximum lifetime can be achieved by following factors:

- Regular cleaning and checking
- Clean and corrosion-protected storage
- Proper de-burring and cleaning of tube end
- Proper tool selection and operation
- Use of specified lubricant

Series	Tube O.D. mm	Pre-assembly tools Order code	Cone-templates Order code
LL	04	VOMO04LLX	KONU04LL
	06	VOMO06LLX	KONU06LL
	08	VOMO08LLX	KONU08LL
	10	VOMO10LLX	KONU10LL
	12	VOMO12LLX	KONU12LL
L	06	VOMO06LX	KONU06L ¹⁾
	08	VOMO08LX	KONU08L ¹⁾
	10	VOMO10LX	KONU10L ¹⁾
	12	VOMO12LX	KONU12L ¹⁾
	15	VOMO15LX	KONU15L
	18	VOMO18LX	KONU18L
	22	VOMO22LX	KONU22L
	28	VOMO28LX	KONU28L
	35	VOMO35LX	KONU35L
	42	VOMO42LX	KONU42L
S	06	VOMO06SX	KONU06L ¹⁾
	08	VOMO08SX	KONU08L ¹⁾
	10	VOMO10SX	KONU10L ¹⁾
	12	VOMO12SX	KONU12L ¹⁾
	14	VOMO14SX	KONU14S
	16	VOMO16SX	KONU16S
	20	VOMO20SX	KONU20S
	25	VOMO25SX	KONU25S
	30	VOMO30SX	KONU30S
	38	VOMO38SX	KONU38S

1) Cone-templates for tube O.D.6 to 12 mm are identical in series L and S.

KONU – Cone-template for tools VOMO/MOK/MOSI

Cone-templates are essential for monitoring wear on pre-assembly tools like VOMO, MOK or MOS.

KONU must be regularly used to prevent fitting failures caused by worn out or damaged tools (DIN 3859-2: max. each 50th assembly).

For proper use see EO assembly instructions, Chapter E.

Specifications:

Material: hardened tool steel

Sizes: 4 LL – 12 LL,
6 L – 42 L,
6 S – 38 S
(Sizes 6 L – 12 L
are identical to 6 S – 12 S)



Features, advantages and benefits of cone-templates:

- 1. Special** – KONU are high precision cone-templates specifically designed and manufactured to match EO standards.
- 2. Maintenance tool** – A leaking fitting can be easily checked and replaced if worn-out.

Tube O.D. mm	Cone gauges Order code
04-LL	KONU04LL
06-LL	KONU06LL
08-LL	KONU08LL
10-LL	KONU10LL
12-LL	KONU12LL
06-L	KONU06L ¹⁾
08-L	KONU08L ¹⁾
10-L	KONU10L ¹⁾
12-L	KONU12L ¹⁾
15-L	KONU15L
18-L	KONU18L
22-L	KONU22L
28-L	KONU28L
35-L	KONU35L
42-L	KONU42L
06-S	KONU06L ¹⁾
08-S	KONU08L ¹⁾
10-S	KONU10L ¹⁾
12-S	KONU12L ¹⁾
14-S	KONU14S
16-S	KONU16S
20-S	KONU20S
25-S	KONU25S
30-S	KONU30S
38-S	KONU38S

¹⁾ Cone-templates for tube o.d. 6 to 12 are identical in series L and S.

Selection guide: Checking equipment for EO assembly

Performance of EO tube connections is depending on perfect condition of pre-assembly tools and proper assembly process.

Cone-templates KONU for monitoring MOK/VOMO tool wear and AKL gauges for checking result of PSR preassembly are available.

KONU – Cone-template for EO pre-assembly tools

Limitations

Cone-template KONU detect wear and deformation of pre-assembly tools like VOMO, MOK or MOS. But it does not indicate failures on completed assemblies.

Cone-template KONU will not detect all possible failures of pre-assembly tools. Pre-assembly tools must be scrapped when they show visual wear or cracks, even if KONU check is OK.

	KONU	AKL
Function	Checking of preassembly tools	Checking of PSR assemblies
Will detect: Deformed MOK/VOMO	Yes, compared to template	Yes, if relevant for PSR performance
Will detect: Visual damage and cracks of MOK/VOMO	No	Yes, if relevant for PSR performance
Will detect: Assembly failures like: tube end not bottomed, underassembly of PSR	No	Yes, if relevant for PSR performance
Will detect: Insufficient bite of PSR	No Visual check required	No Visual check required
Application	Expert template for trained and experienced engineers in workshop	Gauge for production of PSR assemblies

Application

KONU is expert tooling for trained and experienced engineers. For practical

monitoring of assembly result in production, distance gauge AKL are recommended.

Distance Gauge for Assembly AKL



Distance Gauges AKL

Distance gauges AKL are suitable for checking the pre-assembly result of Progressive Rings PSR. They are used on pre-assembled tubes before final installation. The green LED lights up, when none of the following failures is detected:

- Excessive wear of preassembly tools MOK
- Excessive assembly force / pressure setting
- Tube end by far not bottomed in assembly tool MOK.

Therefore, assembly check by cone-tem-plate KONU can be void. Use of distance gauges AKL does not replace the check of the bite (visible collar in front of Progressive Ring).

Specification

Function:	Distance gauge with LED indication
For checking of:	Machine pre-assembly of Parker EO Progressive Ring PSR
Series:	LL/L/S
Tube-OD:	4–38/42 mm
Dimensions:	Length: approx. 130–160 mm Front diameter: approx. 30–52 mm
Power:	2 × Battery AA – Mignon – LR6 (included)
Scope of supply:	Distance gauge with LED indication, batteries, master piece and instructions in a plastic case

Ordering

Size	Order code	Size	Order code	Size	Order code
04-LL	AKL04LL	10-L	AKL10L	10-S	AKL10S
06-LL	AKL06LL	12-L	AKL12L	12-S	AKL12S
08-LL	AKL08LL	15-L	AKL15L	14-S	AKL14S
10-LL	AKL10LL	18-L	AKL18L	16-S	AKL16S
12-LL	AKL12LL	22-L	AKL22L	20-S	AKL20S
06-L/S	AKL06LS	28-L	AKL28L	25-S	AKL25S
08-L/S	AKL08LS	35-L	AKL35L	30-S	AKL30S
		42-L	AKL42L	38-S	AKL38S

Features, Advantages & Benefits of distance gauge AKL

1. Clear – In contrast to the visual evaluation, the simple good/bad decision is obvious, even for less experienced operators.
2. Economical – The distance gauges AKL are fast in application. The production process is not slowed down noticeably compared with other testing methods.
3. Result-oriented – In the comparison to examining the tools with the AKL teachings the assembly result is examined. Thus also the failure opportunity “Tube by far not bottomed” is detected.
4. Practical – The gauges are light, handy, easy, and can be fastened with an eye. Standard batteries are used, so that a long life span is reached.
5. Safe – The measuring head consists of high-grade steel and is not adjustable or detachable. A master piece for regular functional testing is shipped with each AKL gauge.
6. Innovative – For customers of prefabricated hydraulic tubes, so far it was not easy to inspect the assembly quality of incoming goods. Thus incorrect assemblies, which are caused by use of worn pre-assembly tools, remained often undiscovered. With the distance gauges AKL an efficient and effective inspection of incoming goods can be accomplished, allowing pro-active quality management together with the tube supplier.

Limitations

- Distance gauges AKL are suitable only for the inspection of machine pre-assembly. After final tightening of the connection, a failure might be indicated, even if the Progressive Ring was properly assembled by the pre-assembly machine.
- Distance gauges AKL are designed for the use with Progressive Rings PSR. Parker does not take responsibility for the function with other bite type fittings. Distance gauges AKL are not suitable for

checking EO-2 and EO2-FORM connections.

- Use of distance gauges AKL does not replace the check of the bite (visible collar in front of Progressive Ring).

Function

Distance gauges AKL are suitable for checking the effect of worn tools on pre-assembly result of Progressive Rings PSR. They are used on pre-assembled tubes before final installation. The distance gauges AKL particularly detects the position of the Progressive Ring PSR in relation to the tube end. Shining of the green LED indicates that the assembly cone can be further used. Flicker of the green LED is quite possible, since the installed tube in the gauge can have some clearance. If the wear of the assembly tool reaches 0,1 mm on the cone, the LED shines no longer and indicates that the tool is worn. These defective tube assemblies must not be installed and the worn assembly tool must be replaced. The inspection has to take place regularly, at the latest after 50 assemblies. Then, assembly tool check by cone-tem-plate KONU can be void.

Operation

- Shining of the green LED indicates that the assembly cone can be further used
- If the LED doesn't shine, the assembly must not be used



Applications

- Mass production of hydraulic tube assemblies for mobile hydraulics, automotive and agricultural vehicles
- Commercial tube manipulators for hydraulic tube assemblies
- Inspection of incoming tube assemblies at the final installation plant

Manual assembly devices for EO/EO-2 tube connections

Machine selection guide

Manual assembly devices are available to reduce assembly time and effort. High assembly quality and consistency assures reliable fitting performance. EO assembly devices are manually operated and do not need any external power supply.

Due to the low weight, easy handling and simple but reliable design, the EO assembly devices are the ideal tool for tube preparation of small quantities.

For efficient mass production, manual devices are not suitable, therefore EOMAT machines are recommended.



Features, advantages and benefits

- 1. Flexible** – Manual assembly devices are portable and do not need any power supply. Therefore they are ideal for on-site tube assembly, repair and plant maintenance.
- 2. Economic** – Manual assembly devices close the gap in between manual fitting pre-assembly in a vice and the EOMAT technology. The devices contribute to save time and effort in bite type assembly. The little investment pays back immediately.
- 3. Controlled assembly** – After pre-assembly, the tube joint can be easily inspected before final installation. Therefore, this manda-

tory step in fitting assembly is less likely to be forgotten.

- 4. Special** – Each device has been especially developed for the efficient use in a certain application. The HVM-B is a handy tool for the quick pre-assembly of EO Progressive rings onto soft steel tube. The EO-KARRYMAT is a real problem solver when it comes to on-site assembly of medium to large EO-Progressive rings and EO-2 fittings onto steel and stainless steel tube.

How to select the ideal assembly device for your application:

	HVM-B 	EO-KARRYMAT 
Assembly method EO-2: PSR/DPR/D: Triple-Lok®:	not suitable Stroke controlled not suitable	Pressure controlled Pressure controlled not suitable
Tube specification Material: Outside diameter/mm: Min. U-bend: Wall thickness:	Steel 4–15 mm 25 mm no limitation	Steel, Stainless Steel 6–42 mm 66 mm no limitation
Tool specification	Special assembly cones MOSI and plates HL	Standard assembly cones MOK and plates GHP
Operation drive	Lever with eccentric cam	Handpump
Process control	Assembly stroke determined by tool geometry	Pressure control according to selection chart
Preassembly is equal to EO-2: PSR: D/DPR:	– 1 turn 1 turn	Gap closed 1½ turn 1¼ turn
Performance Overall cycle time: Economic production quantity:	10 secs. max. 20 assemblies per day	30–60 secs. max. 50 assemblies per day
Application	Simple tool for quick pre-assembly of small dimension EO-Progressive rings onto steel tubes	Most efficient for one-site assembly of medium to large DPR- and EO-2 connections onto any suitable tube material. Repair jobs and hydraulic services

HVM-B Pre-assembly tool

This pre-installation tool is a simple tool for a quick and safe pre-assembly of EO-Progressive Stop Ring/Progressive ring. The tool is very handy and can be used at any site provided a vice is available. Suitable for LL, L and S series and tube sizes from 4 to 15 mm O.D.

Attention:

- ⚠ **Not suitable for EO-2 assembly.**
- ⚠ **Not suitable for stainless steel progressive ring assembly.**
- ⚠ **Final assembly of ½ turn in fitting body required.**
- ⚠ **Not suitable for tube OD larger 15 mm**

Specifications:

For pre-assembly of: EO Progressive Stop Ring (PSR)/Progressive Ring (DPR)

Pre-assembly equals: 1 turn of nut

For assembly check and fitting installation see assembly instructions chapter E.

Tube O.D.: 4 to 15 mm

Min. U-bend: 25 mm

Series: LL, L and S

Tube and

fitting material: Steel

Weight: approx. 7.0 kg (without tools)

Economic production quantity: max. 20 ass./day

Features, advantages and benefits of pre-assembly tool:

1. **Special** – HVM-B is designed and manufactured to match EO-DPR standards.
2. **Vice mounted** – For easy workshop use, the HVM-B can be clamped into any vice.
3. **Flexible** – A HVM-B can be used anywhere to assure safe fitting assembly – even at assembly sites where EOMAT technology is not available.
4. **Efficient** – There is no doubt that HVM-B-presetting contributes to save time and effort in bite-type assembly. The small investment pays back immediately.

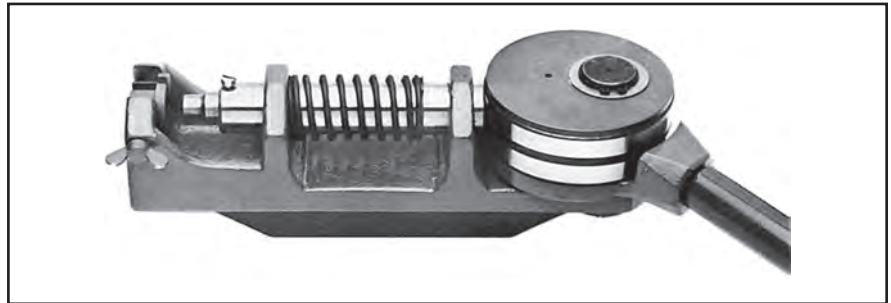

Type	Order code
HVM-B pre-assembly tool device for mount in vice, without tools	HVMBKPLX

Series	Tube O.D. mm	Tube location plate Order code	Assembly cone Order code	Cone-template Order code
LL	4	HL04X	MOSI04LLX	KONU04LL
	6	HL06X	MOSI06LLX	KONU06LL
	8	HL08X	MOSI08LLX	KONU08LL
	10	HL10X	MOSI10LLX	KONU10LL
	12	HL12X	MOSI12LLX	KONU12LL
L	6	HL06X	MOSI06LX	KONU06L ¹⁾
	8	HL08X	MOSI08LX	KONU08L ¹⁾
	10	HL10X	MOSI10LX	KONU10L ¹⁾
	12	HL12X	MOSI12LX	KONU12L ¹⁾
	15	HL15X	MOSI15LX	KONU15L
S	6	HL06X	MOSI06SX	KONU06L ¹⁾
	8	HL08X	MOSI08SX	KONU08L ¹⁾
	10	HL10X	MOSI10SX	KONU10L ¹⁾
	12	HL12X	MOSI12SX	KONU12L ¹⁾
	14	HL14X	MOSI14SX	KONU14S

1) Cone-templates for tube o.d. 6 to 12 are identical in series L and S.

HVM-B Pre-assembly tool

1



2



3

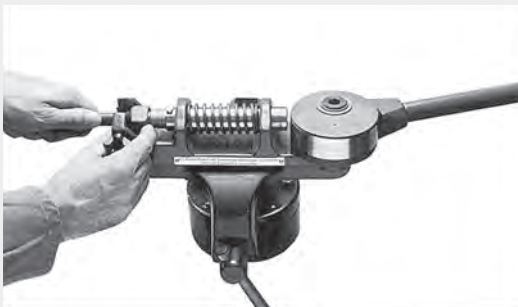

4



5



How to use

- Clamp HVM-B into vice.
- Select required assembly cone (MOSI) and insert.
- The assembly cones are marked with tube O.D. and series (e.g. 10-L).
- Insert the tube location plate – HL – of corresponding size and fasten with screw.
- The tube location plates are marked with tube O.D. (e.g. "10").
- Slip nut "M" and Progressive Stop Ring PSR/Progressive ring "DPR" (or cutting ring "D") over tube end and insert into pre-assembly tool.
- Nut position must be in front of tube location plate – HL – !
- Hold tube against stop in the assembly cone.
- Pull lever to turn the eccentric cam (Pre-assembly).

Attention

⚠ For assembly check and final assembly see PSR/DPR instructions.

Attention:

⚠ At final assembly nut must be tightened by ½ turn.

EO-KARRYMAT portable pre-assembly device for EO tube connections



Type	Order code
EO-KARRYMAT assembly device complete device including handpump and carrying case, including operation manual. Tools (assembly cone MOK and backing plate GHP) must be ordered separately.	EOKARRYMAT
Promotion leaflet UK/DE	4044-DE/UK
Spare parts	
Handpump	82C-2HP
Pressure gauge	EOKARRYMAT/MANO
Pressure chart sticker	EOKARRYMAT/CHART
Cover hinge	EOKARRYMAT/HINGE
Assembly head	EOKARRYMAT/BLOCK

The EO-KARRYMAT is a dependable device for safe and efficient bite-type presetting. It allows pre-assembly of even large dimension steel and stainless steel tube at assembly sites where EOMAT technology is not available.

The EO-KARRYMAT consists of a hydraulic drive and a handpump. The hydraulic assembly pressure can be read on a gauge. The EO-KARRYMAT comes as one unit with all components firmly attached to a practical carrying frame.

Specifications:

For pre-assembly of: EO PSR/DPR and EO-2

Pre-assembly equals:
 EO Progressive Stop Ring (PSR): 1½ turns of nut
 EO Progressive ring (DPR): 1¼ turns of nut
 EO-2 "Gap closed"

⚠ For assembly check and fitting installation see assembly instructions chapter E.

Tube O.D.: 6 to 42 mm
 Min. U-bend: 66 mm
 Series: L and S
 Tube and fitting material: Steel and stainless steel
 Total cycle time: approx 30–60 sec.
 Weight: approx. 28 kg
 Economic production quantity: max. 20 assemblies per day
 Oil: HLP23–1.22 (filled before delivery)







Features, advantages and benefits of EO-KARRYMAT:

- 1. Ideal** – Weighing 28 kg, the EO-KARRYMAT is portable and does not need any power supply. Therefore the EO-KARRYMAT is the ideal tool for on-site tube assembly, repair and plant maintenance.
- 2. Economic** – The EO-KARRYMAT closes the gap in between manual fitting pre-assembly in a vice and the EOMAT technology. EO-KARRYMAT assembly is far less hard work as manual assembly but it achieves the dependent assembly result of the EOMAT assembly machine.
- 3. "Must" for stainless steel** – As direct assembly of stainless steel tubes in bite type fittings results in failure, a special pre-assembly process is mandatory according to ISO 8483 / DIN 3859 and all manufacturers instructions. The EO-KARRYMAT fulfils this requirement.
- 4. Dependable** – The use of the EO-KARRYMAT is far less demanding than manual fitting assembly using wrenches. It helps to prevent failures caused by insufficient fitting assembly which is most critical on large dimension steel and stainless steel tube.
- 5. Controlled assembly** – After pre-assembly, the tube joint can be easily inspected before final assembly. Therefore, this mandatory step in fitting assembly is less likely to be forgotten.
- 6. Special** – The EO-KARRYMAT has been especially developed for the efficient on-site assembly of EO Progressive ring and EO-2 fittings.

The tools are designed to allow safe assembly of even large dimension steel and stainless steel tubes without excessive hard work.

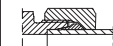
The applications:

- Repair workshops
- Mobile repair service
- Plant maintenance in process engineering, paper production, power plants, offshore exploration, industrial production
- On-site assembly of tubing systems

Tube O.D.	EO-2	PSR/DPR
		
Ø [mm]	P [bar]	P [bar]
6	45	30
8	55	40
10	65	50
12	75	60
14	95	70
15	95	70
16	110	90
18	110	90
20	160	120
22	120	110
25	210	160
28	160	140
30	300	200
35	250	180
38	350	280
42	300	230
		
Installation	min. 60° max. 90°	~ 30°

Assembly machines for EO/EO-2 and Triple-Lok®

Machine selection guide

EOMAT assembly is much more cost efficient than manual assembly of EO-fittings. Assembly time and effort are greatly reduced. Proper and consistent pre-assembly support safe and leakfree fitting performance.

EOMAT machines are specifically designed to match EO-2, EO PSR/DPR rings and Triple Lok® standards. Assembly is achieved with high precision and repeatability.

EOMAT machines are available in several versions to serve individual applications. All machines are designed for reliable workshop use even under severe construction site working conditions. Tool handling and machine operation are simple.

How to select the ideal EOMAT machine for your application:

Features, advantage and benefits:

- 1. Universal** – Assembly of EO-2, EO PSR/DPR rings and 37° flaring for Triple-Lok® can be done with just 1 machine.
- 2. Efficient** – With a cycle time of some 12 to 15 seconds the EOMAT machine greatly saves assembly time and effort. The investment pays back quickly.
- 3. Safe** – Proper pre-assembly greatly reduces the danger of leaking fittings or even hazardous tube blow out.

- 4. Strong** – Even 37° flaring of larger sized stainless steel tube is done within few seconds.
- 5. Flexible** – All tube dimensions from 6 to 42 mm can be used. All common tube materials are covered, even plastic tube (EO-2 and PSR/DPR only).
- 6. Marking notch** – A special ridge makes a circular mark onto the tube end to verify that it was properly bottomed at assembly. Failures caused by improper tube cutting or bottoming in MOK can be recognised before final installation.
- 7. Reliable** – For more than 20 years, hundreds of EOMAT machines have operated under heavy duty workshop conditions.

Selection chart EOMAT Pre assembly and Flaring machines

	EOMAT ECO	EOMAT UNI	EOMAT PRO
Assembly method: EO-2 D/PSR/DPR Triple-Lok®	Pressure controlled Pressure controlled –	Pressure controlled Pressure controlled Conventional 37° flaring	Pressure controlled Stroke controlled –
Tube specification: Material Outside diameter Min. U-bend	Steel, Stainless Steel 6–42 mm 75 mm	Steel, Stainless Steel 6–42 mm 65 mm	Steel, Stainless Steel, copper, nylon PRO22 / PRO42: 4–22/4–42 mm PRO22 / PRO42: approx. 35/70 mm
Wall thickness: EO-2/PSR/DPR Triple Lok®	No limitation not applicable	No limitation 6×1 to 38×4 or 42×3 mm (Tube O.D. × wall thickness)	No limitation –
Operation: Setting	Manual pressure adjustment according to selection chart Depending on: Assembly type; Tube dimension; Tube material	Manual pressure adjustment according to selection chart Depending on: Assembly type; Tube dimension; Tube material	Tool detection and automatic adjustment Manual adjustment of pressure is possible
Process control	Pressure gauge	Pressure gauge	PLC with display
Error detection:	No	No	Warning light and message displayed if deviations in assembly process occur
Memory function	No	No	Memory options for custom application on MOK transponderchip
Oil temperature control	No	No	Warning light and message displayed
Foot operating switch	Not available	Not available	Available
Performance	1 Phase/230 V	1 Phase/230 V	400 V, 50 Hz, 3-phase
Overall cycle time (sec.): EO-2 presetting PSR/DPR presetting 37° flaring	20 25 –	12 15 15	PRO22 / PRO42: approx. 8/10 seconds PRO22 / PRO42: approx. 10/12 seconds –
Economic production quantity:	max. 50 assemblies per day	max. 300 assemblies per day	100 or more assemblies per day
Continuous operating:	50 %	80 %	100 %
Weight	approx. 30 kg	approx. 66 kg	approx. 90 kg
Application	Portable machine for repair and workshops	Universal assembly machine for workshop	Cost-effective commercial production

EOMAT ECO Mobile assembly machine for EO-2 and PSR hydraulic fittings



The EOMAT ECO is a portable machine for the assembly of EO-2 and EO Progressive Ring fittings.

This electro-hydraulic unit is simple to operate; the assembly pressure is set on the digital display. The equipment is simple to use, robust and easy to move.

The EOMAT ECO is an ideal piece of equipment for hydraulic service engineers.

Technical data

Application: assembly of Parker EO-2 and PSR Progressive Ring fittings
assembly of cutting ring fittings to DIN EN ISO 8434-1

Process: pressure-controlled press operation through assembly tools

Drive: electro-hydraulic
Assembly EO-2: gap closed
corresponds to: PSR: 11/2 turns of the nut

Tube material: steel and stainless steel Tube

diameters: 6 to 42 mm
Series: L and S
Min. U-bend: 75 mm
Speed: working stroke 15 to 20 secs, total cycle time approx. 20 to 25 secs
Dimensions: L 750 x W 360 x H 300 mm
Weight: 30 kg
Electrical 230V 1-phase
power rating: 50 Hz 700 W

Operation:

for detailed assembly instructions, see our fittings technology technical handbook, chapter E. For safety information, see machine operating manual.

1. Install assembly cone and backing plate

2. Set the setting pressure on the display in accordance with the chart
3. Insert tube complete with nut and ring
4. Operate START button and keep pressed
5. Hold the tube firmly during the assembly operation and press against the stop
6. The assembly operation is complete when the cylinder has travelled back to its starting position
7. Assembly inspection and final assembly should proceed in accordance with the operating manual.

Performance:

Economic production quantity: max. 100 assemblies per day.

Type	Order code
EOMAT ECO basic machine Ready to operate, including operating manual Without tools, no separate assembly fixture required	EOMATECO230V
Bulletin	4046 via Parker catalogue service EMDC
Operating manual UK/DE/FR/IT/ES	EOMATECO/MANUAL
Pressure chart sticker	EOMATECO/CHART
Standard preventive maintenance	EOMATECO/INSPECTION

Setting pressures

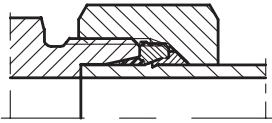
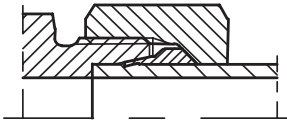
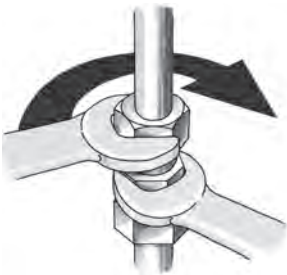
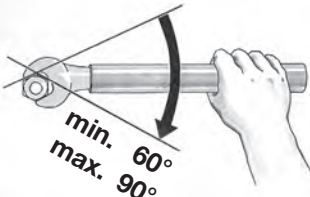
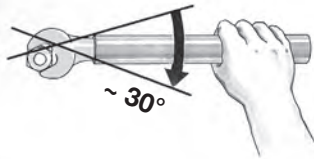
EO [®]	EOMAT ECO		Parker
Tube-O.D.	EO-2	PSR/DPR	
			
Ø (mm)	P (bar)	P (bar)	
6	25	20	
8	35	25	
10	40	35	
12	45	40	
14	60	45	
15	60	45	
16	70	60	
18	70	60	
20	105	75	
22	75	70	
25	135	105	
28	105	90	
30	190	130	
35	160	115	
38	210	180	
42	190	145	
	<p data-bbox="715 1599 871 1630">Installation</p>  <p data-bbox="671 1787 804 1877">min. 60° max. 90°</p>	<p data-bbox="1166 1599 1323 1630">Installation</p>  <p data-bbox="1177 1787 1246 1818">~ 30°</p>	

The stated values are guidelines. The results of pre-assembly should therefore be thoroughly checked.

EOMAT UNI assembly and flaring machine

General

The EOMAT UNI is an electro-hydraulic machine for the assembly of:

EO-2 EO PSR/DPR and Triple-Lok® 37° flared tube fittings.

Compared to manual assembly it greatly reduces assembly time, effort and cost and also guarantees leakfree performance of constant high-quality fitting assemblies.

Common tube materials such as steel (ST 37.4 NBK, ST 52.4 NBK), stainless steel (1.4571/1.4541/316Ti or similar) and copper can be pre-assembled.

The tool range covers all metric tube sizes from 4 to 42 mm outer diameter. The required operating pressure is variable and set at the LED-Display. The unit may therefore be used for a variety of different applications. The tooling for either EO-2/PSR/DPR pre-assembly or tube flaring may be manually replaced, without the use of tools.

Technical data

Tube diameters: 6–42 mm

Min. U-bend: 65 mm

Series: L and S

Oil:

Esso Nuto H 32 or equal, 3.5L (Reference oil change, see label on unit)

Operating pressure:

Variable from 15 to 200 bar

Dimensions:

L 515 mm, W 535 mm, H 285 mm

Performance:

Overall cycletime: 12–15 sec.

Economic production quantity:
max. 300 assemblies per day

Hydraulic pump:

1.2 kW – 3.7 l/min

Electrical connection:

220–240 V / 1~ / 50 Hz / 9.5 A

Connection cable:

5 m – Earth plug

Weight: 66 kg

We reserve the right to make modifications in the course of further technical development.

Features, advantages and benefits:

- Universal** – Assembly of EO-2, EO-PSR/DPR and 37° flaring for Triple-Lok® can be done with just 1 machine.
- Efficient** – With a cycle time of some 15 seconds the EOMAT UNI greatly saves assembly time and effort. The investment pays back quickly.
- Safe** – Proper pre-assembly greatly reduces the danger of leaking fittings or even hazardous tube blow out.
- Strong** – Even 37° flaring of larger sized stainless steel tube is done within few seconds.
- Flexible** – All tube dimensions from 4 to 42 mm can be pre-assembled. All common tube materials are covered.
- Workshop tool** – At 66 kg, the EOMAT UNI can be brought to an assembly site.
- Marking ridge** – All MOK tools feature a special ridge in the bottom surface which is designed to make a circular groove into the tube-end at assembly. No mark indicates that the tube-end has not been properly bottomed at assembly.
- Reliable** – For more than 20 years, hundreds of machines are operated under heavy duty workshop conditions.

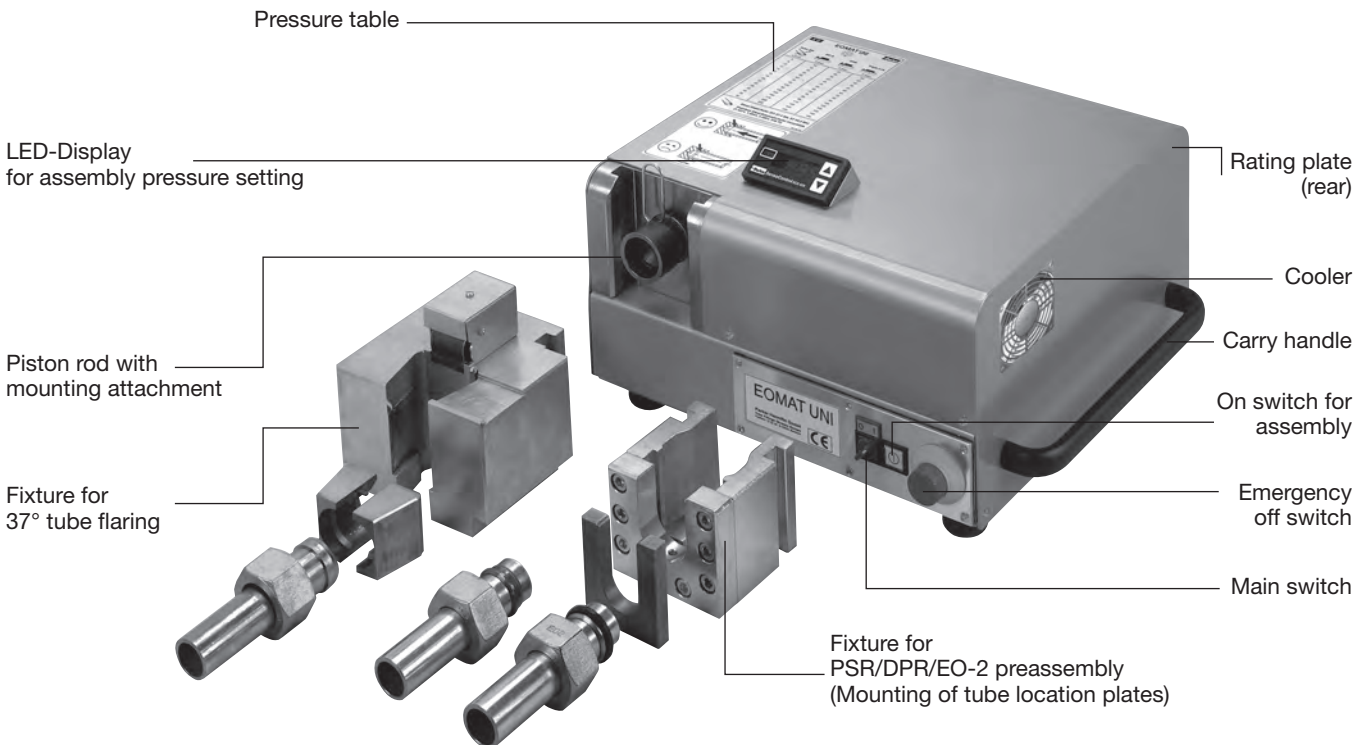

EOMAT UNI assembly and flaring machine

Basic operation for EO-2

Functional nuts

See EO-2 instructions for fitting assembly

1. Adjust EO-2 pressure according to chart (A)
2. Insert the pre-assembly fixture in the tool mounting (weight approx. 5.5 kg).
3. Select the assembly cone (MOK) and backing plate (GHP) in accordance with the tube size and type.
4. Place and lock the assembly cone in the tool holder. Place the backing plate in the slot in the fixture.
5. Slide the EO-2 functional nut onto the tube, which has been cut off square and deburred.
6. Place the tube with the EO-2 functional nut in the pre-assembly fixture between backing plate and assembly cone.
7. Press the tube against the stop in the assembly cone. Hold the tube in this position. Press and hold the start button until the pre-assembly process is complete.
8. Take the assembled tube connection out of the location plate. See EO-2 assembly instruction (chapter E) for assembly check and installation instructions.
9. Check assembly result before final installation.

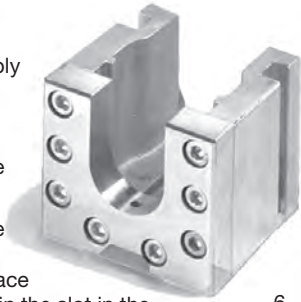

Basic operation for EO PSR/DPR ferrules

See PSR/DPR instructions for fitting assembly

1. Adjust PSR/DPR pressure according to chart (A)
2. Insert the pre-assembly fixture in the tool mounting (weight approx. 5.5 kg).
3. Select the assembly cone (MOK) and backing plate (GHP) in accordance with the tube size and type. Check the assembly cone using a cone-template.
4. Place the assembly cone in the tool holder. Place the backing plate in the slot in the fixture.
5. Oil the ring, nut and assembly cone.
6. Slide the nut and ring onto the tube, which has been cut off square and deburred.
7. Place the tube with nut and progressive ring or cutting ring in the pre-assembly fixture between backing plate and assembly cone.
8. Press the tube against the stop in the assembly cone. Hold the tube in this position. Press and hold the start button until the pre-assembly process is completed.
9. Take the pre-assembled tube out of the backing plate. See EO PSR/DPR assembly instruction (chapter E) for assembly check and installation instructions.
10. Check assembly result before final installation.

Basic operation for 37° tube flaring

See Triple-Lok® instructions for fitting assembly

1. Adjust Triple-Lok® pressure according to chart (A)
2. Insert the tube flaring fixture in the toolmounting (weight approx. 19.5 kg).



3. Lubricate the flaring pin.
4. Insert the flaring die set corresponding to the tube size.
5. Push the nut and support sleeve onto the tube.
6. Push the tube through the flaring die hole to the stop plate. To prevent misalignment, longer tubes are to be supported during the flaring process.
7. Press and hold START button until flaring process is completed.
8. Lift the tube with the flaring die upwards out of the fixture.
9. To release the tube, place the flaring die set in the opening provided in the fixture and tilt the tube to one side.
10. Check assembly result before final installation.

Important!

Only proceed with pre-assembly when a tube with nut and cutting ring has been placed in the fixture (failure to observe this can result in damage to the tools). Longer tubes are to be suitably supported during pre-assembly. The assembly cones are to be regularly checked for correct dimensions using the cone-template and should be replaced when necessary.

Caution: do not reach into the working area of the pre-assembly fixture while it is operating!







Important!

Do not drive the flaring pin into the flaring die without a tube in position. The roughened surface of the flaring die must be absolutely free of oil and grease to prevent the tube from slipping.

Caution: do not reach into the working area of the flaring fixture while it is operating!

EOMAT UNI assembly and flaring machine

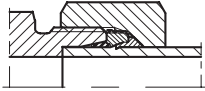
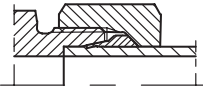
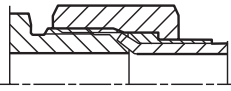
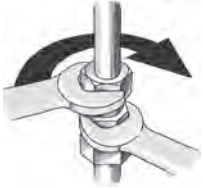
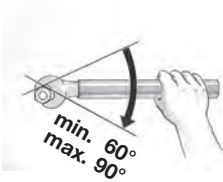
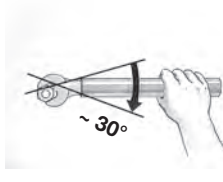
Pressure setting chart A

		<h1>EOMAT UNI</h1>			
					
Tube-O.D.	EO-2	PSR/DPR	Triple-Lok®		
 Ø (mm)	 P (bar)	 P (bar)	 P (bar)		
6	30	25	20		
8	35	30	25		
10	45	35	35		
12	50	40	35		
14	60	50	45		
15	60	50	60		
16	70	55	60		
18	70	55	70		
20	100	80	95		
22	80	75	95		
25	130	100	105		
28	100	90	125		
30	180	125	135		
35	150	110	155		
38	200	170	165		
42	180	140	185		
 Installation	 min. 60° max. 90°	 ~ 30°	 min. 60° max. 90°		
	Steel (ST 37.4 NBK, ST 52.4 NBK, ...)				
	Stainless Steel (ST 1.4571, 1.4541, 1.4301, 316 Ti, ...)				

The given values are a guide. The results of pre-assembly and/or tube flaring are therefore always to be checked. For detailed instructions on tube preparation, tool selection, assembly check and final installation see chapter E.

Assembly tooling

EOMAT UNI assembly and flaring machine

Ordering

Type	Order code
EOMAT UNI Basic machine Ready to use, including operation manual Filled with hydraulic oil Without EO assembly fixture/Flaring fixture Without tools for EO-assembly/37° flaring Basic machine 230 V, 1 Phase, 50 Hz Rental (monthly usage)	EOMATUNI230V EOMATRENTFEE
Fixture for PSR/DPR/EO-2 assembly	EOMATSCHNEIDRX
37° Flaring fixture for Triple-Lok® including flaring pin	EOMATBOERDELBX
EOMAT UNI promotion leaflet UK	4042/UK
EOMAT UNI promotion leaflet DE	4042/DE
EOMAT UNI operating manual UK/DE/FR/IT	EOMATUNI/MANUAL
Standard preventive maintenance	EOMATUNI/INSPECTION

Assembly fixtures, tools, cone-templates, and lubricant must be ordered separately

Assembly tools for PSR/DPR/EO-2 see page H19.

37° flaring tools for Triple-Lok® see page H37.

Spare parts

Type	Order code
Fixing clip for MOK	EOMAT/CLIP
37° flaring pin	EOMAT/FLAREPIN
O-ring for flaring pin	EOMAT/0212500
Tube stop assembly for flaring block	EOMAT/0213800
Pressure chart sticker	EOMATUNI/CHART
Spring for flaring block	EOMAT/0213500

EO PSR/DPR and EO-2 assembly tools for EO-KARRYMAT/EOMAT ECO/EOMAT UNI



Assembly cone MOK



Tube locating plate GHP



Cone-template KONU for MOK



Assembly fixture must be installed on EOMAT UNI II/III

Size		Order code				
Series	Tube-O.D.	Assembly cones for EO PSR/DPR MOK	Assembly cones for EO-2 ³⁾ MOK	Backing plates GHP	Distance control gauges AKL	Cone-templates KONU
LL	4	MOK04LLX	as MOK for PSR/DPR	GHP04X	AKL04LL	KONU04LL
	6	MOK06LLX		GHP06X	AKL06LL	KONU06LL
	8	MOK08LLX		GHP08X	AKL08LL	KONU08LL
	10	MOK10LLX		GHP10X	AKL10LL	KONU10LL
	12	MOK12LLX		GHP12X	AKL12LL	KONU12LL
L	6	MOK06LX	MOKEO206L	GHP06X ¹⁾	AKL06LS	KONU06L ¹⁾
	8	MOK08LX	MOKEO208L	GHP08X ¹⁾	AKL08LS	KONU08L ¹⁾
	10	MOK10LX	MOKEO210L	GHP10X ¹⁾	AKL10L	KONU10L ¹⁾
	12	MOK12LX	MOKEO212L	GHP12X ¹⁾	AKL12L	KONU12L ¹⁾
	15	MOK15LX	MOKEO215L	GHP15X	AKL15L	KONU15L
	18	MOK18LX	MOKEO218L	GHP18X	AKL18L	KONU18L
	22	MOK22LX	MOKEO222L	GHP22X	AKL22L	KONU22L
	28	MOK28LX	MOKEO228L	GHP28X	AKL28L	KONU28L
	35	MOK35LX	MOKEO235L	GHP35X ²⁾	AKL35L	KONU35L
	42	MOK42LX	MOKEO242L	GHP42X ²⁾	AKL42L	KONU42L
S	6	MOK06SX	MOKEO206S	GHP06X ¹⁾	AKL06LS	KONU06L ¹⁾
	8	MOK08SX	MOKEO208S	GHP08X ¹⁾	AKL08LS	KONU08L ¹⁾
	10	MOK10SX	MOKEO210S	GHP10X ¹⁾	AKL10S	KONU10L ¹⁾
	12	MOK12SX	MOKEO212S	GHP12X ¹⁾	AKL12S	KONU12L ¹⁾
	14	MOK14SX	MOKEO214S	GHP14X	AKL14S	KONU14S
	16	MOK16SX	MOKEO216S	GHP16X	AKL16S	KONU16S
	20	MOK20SX	MOKEO220S	GHP20X	AKL20S	KONU20S
	25	MOK25SX	MOKEO225S	GHP25X	AKL25S	KONU25S
	30	MOK30SX	MOKEO230S	GHP30X	AKL30S	KONU30S
	38	MOK38SX	MOKEO238S	GHP38X	AKL38S	KONU38S

Flaring tools see KARRYFLARE

1) Backing plates, cone-templates and flaring die sets for series L and S for tube outer diameter 6, 8, 10 and 12 are the same.

2) **Note:** Two-part backing plates for tube OD 35 and 42.

3) Special MOK for easy tube insertion. MOK for EO-2 are marked with groove.

Tool mounting rack

Practical rack for storing 10 pieces each assembly cone MOK and backing plate GHP.

Type	Order code
Tool mounting rack for GHP and MOK	EOMATWERKZGAUFN.X



Tool lifetime

Assembly tools are subject of wear and must be regularly (max. 50 assemblies) cleaned and checked (Checking instructions see chapter E). Worn out tools can cause dangerous assembly failures and must be replaced in time. Maximum lifetime can be achieved by following factors:

- Regular cleaning and checking
- Clean and corrosion-protected storage
- Proper de-burring and cleaning of tube end
- Proper tool selection and operation
- Use of specified lubricant
- MOK EO-2 don't wear out

Assembly tooling

Ferulok assembly tools for EO-KARRYMAT/EOMAT ECO/EOMAT UNI



Assembly cone



Back-up plate

Size		Order code	
Dash size	Tube-O.D. inch	Back-up plate	Assembly cone
4	1/4	975867-4	976521-4
6	3/8	975867-6	976521-6
8	1/2	975867-8	976521-8
10	5/8	975867-10	976521-10
12	3/4	975867-12	976521-12
14	7/8	975867-14	976521-14
16	1	975867-16	976521-16
20	1 1/4	975867-20	976521-20
24	1 1/2	975867-24	976521-24
32	2	975867-32	976521-32

Assembly tools for inch tube bite type FERULOK.
Machine setting according to correspondent size EO DPR.

EOMAT PRO – Economic assembly machine for EO-2 and progressive ring fittings



The EOMAT PRO is a powerful machine for economical and safe tube installations. The device is designed for installation of Parker EO-2 and progressive ring fittings to DIN EN ISO 8483-1 (DIN 2352) with common tube materials (steel, stainless steel, copper, nylon). The EOMAT PRO is fast and quiet. It permits the assembly of very tight and complex tube bends. Automatic tool detection guarantees short set-up times and prevents errors due to setting the device incorrectly. Unlike conventional cutting ring assembly devices, the EOMAT PRO is stroke-controlled and produces accurate and reproducible assembly results.

The EOMAT PRO can be used in automatic or manual mode. In automatic mode, the settings are read from a transponder chip in the tool. The operator cannot change the device settings in automatic mode.

In the display the tube diameter and the type of installation (EO-2 or progressive ring) will be shown.

There is also a useful piece counter which can be reset by the operator.

Other messages can appear about the assembly cones – for example, notifications about routine checks and tool lifetime. If there is a significant, implausible variation, the display will show an error message. If universal MOK tools are used with universal parameters, this means that only implausible gross deviations will be displayed.

Adaptive assembly cones (MOK-RW) permit the operator to control and set the installation parameters and limits in a few simple steps. In this way the tool is optimized for the specific installation. These individual parameters deliver the best results for the tube material, wall thickness and lubricant used. The device will show slight deviations from the nominal values with a red warning light and a prompt in the display to check the installation. It is therefore possible to detect connections that have been incorrectly installed, check them and remove from the process if needed (e.g. the ring was mounted the wrong way around).

Automatic tool detection, the stored installation values and the display of error messages (red warning light and display) cannot be deactivated in automatic mode by the operator.

In manual mode, different installation values can be set. Manual mode is activated using a key switch. The key is supplied with every device.

The device comes in two versions:

- The quick EOMAT PRO22 for tube sizes up to 20-S/22-L. It has a compact assembly head for tight tube bends.
- The powerful EOMAT PRO42 with a robust assembly head for all sizes up to 38-S/42-L.

Technical data

Application:	Economical mass production of Parker EO tube connections Installation of Parker EO-2 and progressive stop ring (PSR) fittings Installation of cutting ring fittings in accordance with DIN EN ISO 8434-1
Process:	Automatic mode PSR: Stroke-controlled assembly with plausibility check Manual mode and EO-2: Pressure-controlled assembly without error detection
Installation requires:	EO-2: Gap to be closed PSR: 1½ turns of the union nut Other products: See the manufacturer's documentation
Tube material:	Steel, stainless steel, copper, nylon
Tube specification:	All permitted tubes for use with Parker EO couplings
Tube diameter:	EOMAT PRO22: 4 to 22 mm (except for EO-2 – 20-S) EOMAT PRO42: 4 to 42 mm
Range:	LL, L and S
Min. U-bend:	EOMAT PRO22: approx. 35 mm EOMAT PRO42: approx. 70 mm
Tool Identification:	Uses RFID technology, the transponder is in the MOK assembly cone
Error detection:	Plausibility check of the installation parameters after installation
Display:	Text messages and warning light
Available languages:	German, English, French, Spanish, Italian
Display:	Automatic mode: Type of fitting, tube diameter and range Manual mode: Pressure set Piece counter (resettable)
Error messages:	“Check installation result” in the case of non-plausible installation parameters. Reminder to check the tool after every 50 uses. Reminder to change the tool when the end of its lifetime is reached. Warnings about critical hydraulic oil level and temperature.

Assembly tooling

Speed: EOMAT PRO 22: ca 1.0 s stroke distance, ca 8–10 s total cycle time
 EOMAT PRO 42: ca 2.0 s stroke distance, ca 10–12 s total cycle time

Economic production quantity: above 100 assemblies per day
 Operating duration: 100%
 Noise: Less than 75 dB (A)

Ambient temperature: 0 °C to +40 °C
 Storage temperature: –25 °C to +60 °C
 Parameters: No condensing humidity
 Dimensions: L 620 mm×W 735 mm×H 340 mm
 Weight: 90 kg

Operational resources: Esso Hydraulic Oil Nuto H32 or equivalent (filled for delivery)

Electrical power: 400 V 3-phase 50 Hz 1100 W
 Cable: 5 m cable with CEE 16 A phase-inverter plug

Tools: EOMAT PRO 22: MOK PRO assembly cones and MOS compact rear supports
 EOMAT PRO 42: MOK PRO assembly cones and GHP standard backing plates

Lubricant: EO-NIROMONT
 Test equipment: AKL distance gauges

3. Fit the tube with the union nut and ring
4. Press and hold the START button
5. Hold the tube securely through the whole assembly process and push it into the limit stop
6. The assembly process is finished when the cylinder moves back to the starting position
7. Assembly inspection and final assembly is done according to the assembly instructions (see chapter E)

Tool lifetime

Assembly tools are subject to wear, and must be periodically (at least every 50 assemblies) cleaned and inspected (inspection instructions, see chapter E) Worn tools can cause dangerous assembly failures, and need to be replaced in good time. High tool life can be achieved by:

- Regular cleaning and lubrication
- Store protected from dirt and corrosion
- Careful trimming and cleaning of the tube ends
- Proper tool selection and operation
- Use of the recommended lubricant

The MOK PRO assembly cones are made from wear-resistant tool steel, and are therefore suited to mass production. After this lifespan is reached, the display will show that a tool change is needed. The worn tool should be **replaced**, it will no longer work in automatic mode. Worn assembly cones can be used after the end of their expected lifespan in manual mode with care.

EOMAT PRO – features, advantages and benefits

- Low unit costs due to its fast and efficient hydraulic drive
- Compact assembly head for tight and complex bends
- Long lifespan of the assembly tools
- Settings are automatically read from the tool
- Stroke-control achieves a consistently good fitting result
- In automatic mode the operator cannot adjust the installation parameters
- A display showing the number of pieces processed and any error messages
- Adaptive tools for optimal installation parameters and the best possible error detection
- Oil volume and the heat capacity is designed to cope with mass assembly under continuous or shift working patterns
- The foot switch allows the operator a high degree of flexibility

Operation

Detailed installation instructions and safety information can be found in the operation manual

1. Insert the assembly cone and backing plate
2. In automatic mode, the display shows the mounting type and dimensions

Machine/Item	Order code
EOMAT PRO machine , ready to use, with key for selection switch Auto/Manual, with operation manual, filled with hydraulic oil, without tooling and accessories	
EOMAT PRO22 Tube-OD 4–22 mm 400 V, 50 Hz, 3 Phase Renting (monthly rate) Leasing (2 year hire purchase)	EOMATPRO22400V EOMATPRORENTFEE EOMATPROLEASEFEE
EOMAT PRO42 Tube-OD 4–42 mm 400 V, 50 Hz, 3 Phase Renting (monthly hire rate) Leasing (2 year hire purchase)	EOMATPRO42400V EOMATPRORENTFEE EOMATPROLEASEFEE
Accessoires/Item	
EO-NIROMONT Liquid lubricant in a brush-in-cap can (250 cc)	EONIROMONTAPPLICATOR
Foot switch	FOOTSWITCHSAFETYKIT
Fixing clamp for MOK	EOMATPRO/CLIP
Spare key for selection switch	EOMATPRO/KEY
EOMAT PRO promotion leaflet UK	4043 via Parker Catalogueservice EMDC
Operation manual UK/DE/FR/IT/ES	EOMATPRO/MANUAL
Standard preventive maintenance	EOMATPRO/INSPECTION

Assembly tools for EO fittings

Size		Tool order code						
Series	Pipe OD (mm)	Adaptive assembly cone for progressive ring	Standard assembly cone for progressive ring	Standard assembly cone for EO-2	Backing plate for EOMAT PRO42	Compact backing plate for EOMAT PRO22	Distance gauge only for progressive ring	Cone template for assembly cone
LL	04	MOK04LLPRORW	MOK04LLPRO	-	GHP04X	GHP04PRO	AKL04LL	KONU04LL
	06	MOK06LLPRORW	MOK06LLPRO	-	GHP06X	GHP06PRO	AKL06LL	KONU06LL
	08	MOK08LLPRORW	MOK08LLPRO	-	GHP08X	GHP08PRO	AKL08LL	KONU08LL
	10	MOK10LLPRORW	MOK10LLPRO	-	GHP10X	GHP10PRO	AKL10LL	KONU10LL
	12	MOK12LLPRORW	MOK12LLPRO	-	GHP12X	GHP12PRO	AKL12LL	KONU12LL
L	06	MOK06LPRORW	MOK06LPRO	MOKEO206LPRO	GHO06X	GHP06PRO	AKL06LS	KONU06L
	08	MOK08LPRORW	MOK08LPRO	MOKEO208LPRO	GHP08X	GHP08PRO	AKL08LS	KONU08L
	10	MOK10LPRORW	MOK10LPRO	MOKEO210LPRO	GHP10X	GHP10PRO	AKL10LL	KONU10L
	12	MOK12LPRORW	MOK12LPRO	MOKEO212LPRO	GHP12X	GHP12PRO	AKL12LL	KONU12L
	15	MOK15LPRORW	MOK15LPRO	MOKEO215LPRO	GHP15X	GHP15PRO	AKL15L	KONU15L
	18	MOK18LPRORW	MOK18LPRO	MOKEO218LPRO	GHP18X	GHP18PRO	AKL18L	KONU18L
	22	MOK22LPRORW	MOK22LPRO	MOKEO222LPRO	GHP22X	GHP22PRO	AKL22L	KONU22L
	28	MOK28LPRORW	MOK28LPRO	MOKEO228LPRO	GHP28X	-	AKL28L	KONU28L
	35	MOK35LPRORW	MOK35LPRO	MOKEO235LPRO	GHP35X	-	AKL35L	KONU35L
	42	MOK42LPRORW	MOK42LPRO	MOKEO242LPRO	GHP42X	-	AKL42L	KONU42L
S	06	MOK06SPRORW	MOK06SPRO	MOKEO206SPRO	GHP06X	GHP06PRO	AKL06LS	KONU06L
	08	MOK08SPRORW	MOK08SPRO	MOKEO208SPRO	GHP08X	GHP08PRO	AKL08LS	KONU08L
	10	MOK10SPRORW	MOK10SPRO	MOKEO210SPRO	GHP10X	GHP10PRO	AKL10S	KONU10L
	12	MOK12SPRORW	MOK12SPRO	MOKEO212SPRO	GHP12X	GHP12PRO	AKL12S	KONU12L
	14	MOK14SPRORW	MOK14SPRO	MOKEO214SPRO	GHP14X	GHP14PRO	AKL14S	KONU14S
	16	MOK16SPRORW	MOK16SPRO	MOKEO216SPRO	GHP16X	GHP16PRO	AKL16S	KONU16S
	20	MOK20SPRORW	MOK20SPRO	MOKEO220SPRO	GHP20X	GHP20PRO	AKL20S	KONU20S
	25	MOK25SPRORW	MOK25SPRO	MOKEO225SPRO	GHP25X	-	AKL25S	KONU25S
	30	MOK30SPRORW	MOK30SPRO	MOKEO230SPRO	GHP30X	-	AKL30S	KONU30S
38	MOK38SPRORW	MOK38SPRO	MOKEO238SPRO	GHP38X	-	AKL38S	KONU38S	
		Programmable with individual parameters for plausibility checks	Programmed with universal parameters without effective error detection	Programmed with universal parameters without effective error detection	Also suitable for EO-KARRYMAT and all EOMAT devices from Parker	Only suitable for the EOMAT PRO 22 device from Parker	To check the assembly result of Parker EO Progressive rings (not for EO-2)	To check wear of MOK assembly cones for progressive rings (not MOK EO-2)

The WorkCenter F3

All aboard

The WorkCenter F3 is completely automatic in operation and has been designed for practical workshop application. Opening

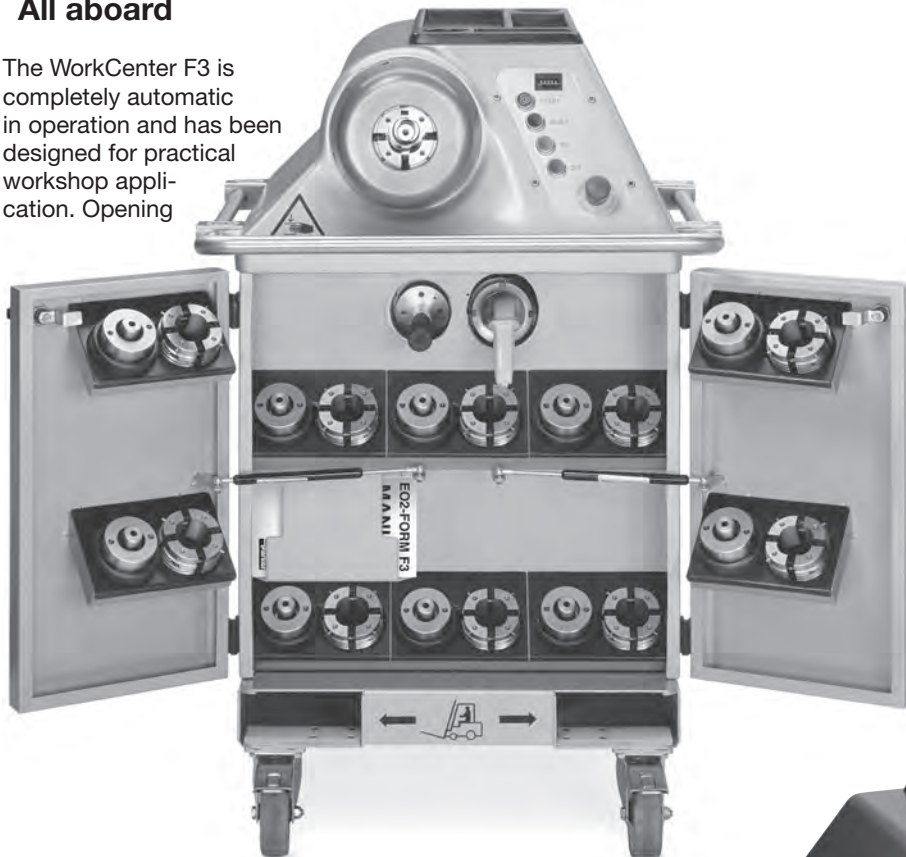

the doors turns the machine into a totally equipped WorkCenter. The tool storage area is located in the front – the tools are neatly laid out and easily viewed. No other workbenches or tool racks are required. Special convenient-to-handle tools make the machine set-ups and tool changes easier. Thanks to automatic tool recognition, the operator has only to press the start button, whereupon the tube is formed into the correct shape in one pass. This means that EO2-FORM connections are extremely simple to manufacture. The WorkCenter F3 is so reliable because of its powerful hydraulic drive and robust forming tools.

- Workshop machine for universal use
- 6 to 38/42 mm tube OD
- Cycle time approx. 20 seconds
- Especially advantageous for: Hydraulic presses, cranes and lifts, heavy machinery, shipbuilding, offshore and hydraulic steelworks

The WorkCenter PRO22

Mass production without tears

The WorkCenter PRO22 is based on proven EO2-FORM technology and was specially designed for the economic production of EO2-FORM tube fittings. Compared with the WorkCenter F3, the PRO22 production machine works considerably more efficiently and can machine tighter tube bends. Because of its powerful drive and efficient cooling, continuous mass production on a shift-work basis is provided for. In addition, the machine is especially quiet and vibration-free in operation. Small to

medium tubes from 6 to 22 mm can be accommodated on the new machine. The compact assembly head enables even tight tube bends to be machined.

- Production machine for economical and fail-safe manufacturing
- 6 to 22 mm tube OD
- Cycle time approx. 6 seconds
- Advantageous for applications such as: manufacturers of agricultural machinery, construction machines, trucks, fork lift trucks and other mass-produced hydraulic equipment



EO-KARRYFORM

Lightweight. Portable. Cost Saving.

With the portable EO-KARRYFORM forming machine tear-out resistant tube connectors in steel and stainless steel can be done directly at the point of installation.

The EO-KARRYFORM can produce tubes with outside diameters ranging from six to 42 mm. The EO-KARRYFORM consists of a hydraulic drive unit in a mobile trolley and a forming

cylinder, which can be safely connected by means of Parker hydraulic hoses and quick couplings. The tools, consisting of clamping dies and forming pins plus insertion tools, are transportable separately in a dedicated tool box. This lightweight machine, weighs approximately 135 kg, allowing it to be quickly and safely transported in, for example, a suitable van to the assembly point.

The EO-KARRYFORM concept is cost saving because F3 and PRO22

WorkCenter tools can also be used for forming processes. Cycle time is approximately 20 seconds and the smallest 180° elbow is 115 mm. This new machine can be easily deployed for both mobile service on-site directly at the assembly point, and also for conventional workshop operation.

- Portable machine for the production of tear-out tube connections
- 6 to 38/42 mm tube OD
- Cycle time approx. 20 seconds
- Beneficial for: Workshops, directly at the assembly point

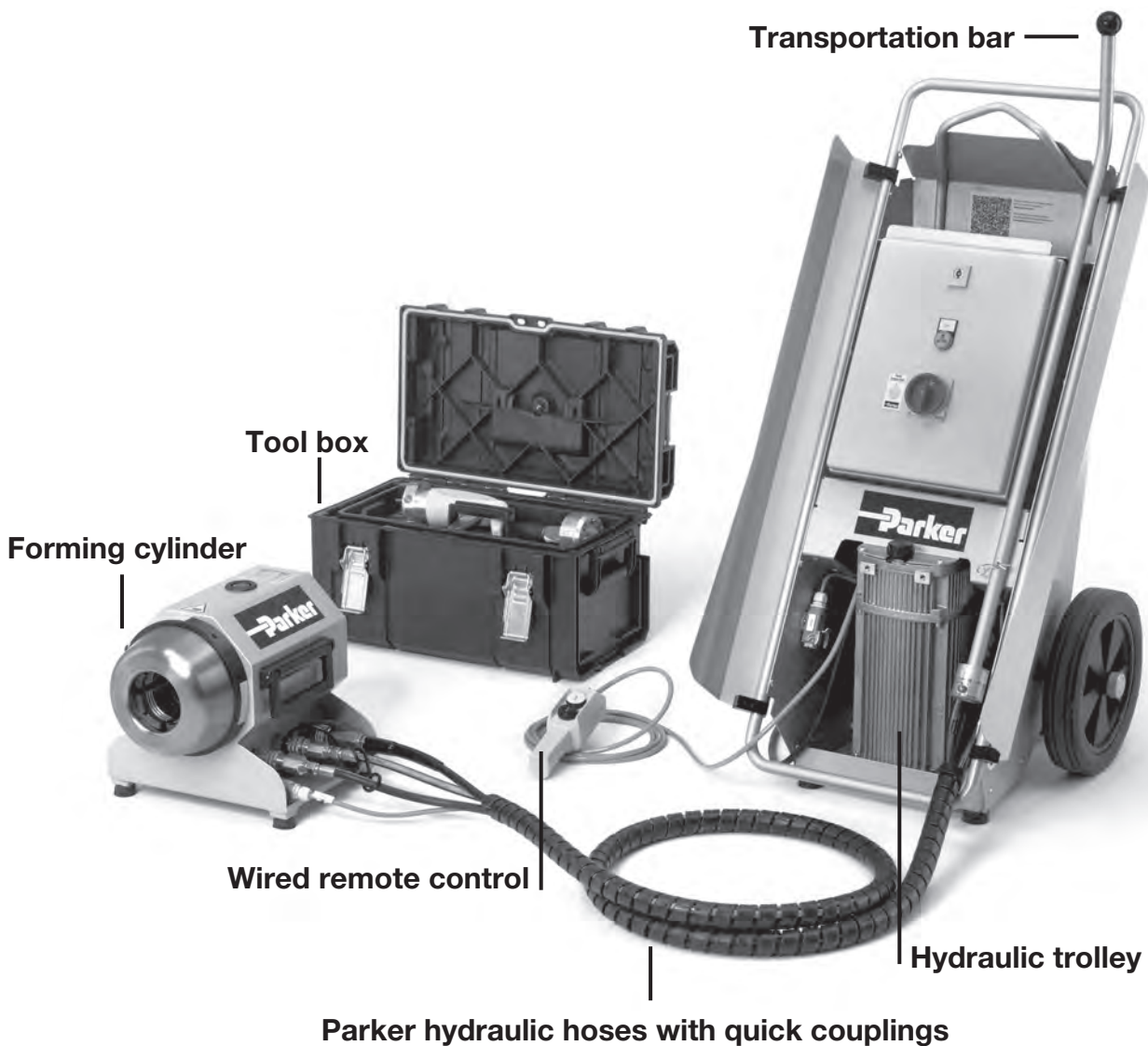

Assembly tooling

WorkCenter F3, PRO22 and EO-KARRYFORM

Technical Data	
Machine	WorkCenter F3, PRO22 and EO-KARRYFORM
Designated use	Cold forming of tube ends for tube connections
Method	Axial swaging
Suitable for	EO tube fittings to DIN EN ISO 8434-1 Hose Connections to DIN 71550
Tube specification	
Steel tubing	E235 / ST37.4; E355 / ST52.4
Stainless steel tubing	1.4571
Other materials	CuNiFe, duplex and others on request
Boiler tube	Tubes for turbine construction on request
Tools	Interchangeable
Forming die sets	"MF3" single part forming die sets, one type for each tube OD
Forming pin	"BF3" forming pin with inner mandrel, one type each per tube OD, wall thickness and material
Function	
Tool change	Manual
Setting	WorkCenter: Automatic tool recognition and pressure setting EO-KARRYFORM: Pressure setting acc. to pressure table
Tube clamping	Hydraulic
Forming	Hydraulic
Controls	Automatic sequence: after pressing START button: Clamp – form – withdraw – unclamp
Environmental conditions	
Working temperature	WorkCenter: +10 ... +50°C EO-KARRYFORM: +10 ... +40°C
Relative humidity	Msc. 90%, non-condensing

Type	WorkCenter F3	WorkCenter PRO22	EO-KARRYFORM
Specifications			
Type	Universal workshop machine	Powerful production machine	Portable forming machine
Design	WorkCenter	WorkCenter	Portable machine for repair and workshop tasks
Application	Alternative to welding	Efficient mass production	Alternative to welding
Weight	Approx. 330 kg	Approx. 375 kg	Hydraulic drive unit: 69 kg Forming cylinder: 67.5 kg Tool box: approx. 10 kg
Dimensions (LxBxH)	660 x 800 (open: 1,300)x1,150	660 x 800 (open: 1,300)x1,200	Drive Unit: 500 x 600 x 1200 Forming cylinder: 330 x 420 x 325 Tool box: 335 x 550 x 310 Length of hydraulic hoses: 3150
Electrical supply	400 V, 50 Hz, 3 phase 230 V, 50 Hz, 3 phase 440 V, 60 Hz, 3 phase	400 V, 50 Hz, 3 phase	230 V, 50 Hz, 1 phase
Electric motor drive rating	4 kW	4 kW	1.1 kW
Oil cooler	Optional	Standard	—
Performance data			
Steel tube	6x1 ... 38x7/42x4	6x1 ... 20x2/22x2	6x1 ... 38x5/42x4
Stainless steel tube	6x1 ... 38x5/42x3	6x1 ... 20x2/22x2	6x1 ... 38x4/42x3
Minimum width U-bend	Approx. 135 mm	Approx. 100 mm	Approx. 115 mm
Cycle time	15–20 sec.	Ca. 6 sec.	15–20 sec.
Economic production quantity	Max. 100 formings/hour Max. 200 forming/hour (with oil cooler)	Max. 600 formings/hour	Max. 100 formings/hour
Applications	Ideal for project and workshop tasks, small batches and on-site installations. Tubes of all sizes.	Economic mass production of small to medium tube dimensions	Ideal for repair, installation projects and workshop tasks for small batches. Tubes of all sizes.

Features, advantages and benefits

1. **Process / Product concept** – The EO2-FORM technology is not a stand-alone machine or a new fitting system. It is a product extension of the EO-2 range which has existed since 1993. Exactly the same, proven seal elements are used.
2. **Workcenter concept** – All tools, handling devices, lubricants and the operator manual are well organised inside the machine. Once the doors are opened, the machine turns into a stand-alone workcenter for tube preparation. On the top shelf, there are practical compartments for rules, pens, lubricant and standard EO-boxes with nuts and sealing rings. No additional workbenches or shelves for tooling are required.
3. **Easy operation** – One single START-button is all that needs to be operated to run a forming cycle completely. No “zero position” or “reset” activities have to be performed in-between two forming cycles. For efficient mass production, a foot switch is available. A label on the machine head shows all operation steps in pictograms and all important dimensions in charts.
4. **Easy tool change** – An ergonomic, pistol-like device allows quick and easy change of the one-piece clamping die set without opening the forming head or even touching the tools. Another handle speeds up the setup process of the forming pin in the bayonet mechanism.
5. **Easy handling** – Standard tools and one set of EO-2 sealing rings are suitable for all common hydraulic tube dimensions. No special sleeves are required for thin wall or small diameter tube.
6. **Well organised** – All tools and accessories are well organised in a practical compartment inside the machine housing. Nothing gets dirty, lost or confused.
7. **Easy transport** – The machine is equipped with heavy duty wheels so that it can be moved around by one person without hard work or additional equipment. Special attachments for crane and forklift truck transport are standard. A reeling serves as handle, protection and attachment for fixing belts when transported by truck. Tools and all accessories are safely and cleanly stored inside.
8. **Easy logistics** – EO2-FORM uses the same components as EO-2. Special sets of nuts and sealing rings can be ordered with one part number (FORM ...). This reduces ordering effort and contributes to achieve availability with optimum inventory.
9. **Stainless steel capabilities** – Forming pins for stainless steel tubes are specially designed for optimum forming results and surface coated for maximum lifetime. All forming pins for stainless steel tube are marked with a blue dot. Clamping dies can be used for both, steel and stainless steel tube.
10. **Approved functional system** – EO2-FORM has been on market for years. It is approved for use in shipbuilding, offshore industry, hydraulic water lock systems, press and crane manufacturing, heavy mobile equipment and general machine building. EO2-FORM is tested and approved from authorities like German Lloyd, DNV or from end-users like Daimler-Chrysler.
11. **Cost saving** – Compared to welding or brazing, EO2-FORM are much less time consuming. Special tube preparation and finishing are not necessary. Cold forming uses only a fraction of the energy needed for brazing or welding.
12. **Superior vibration resistance** – The process achieves a smooth structural transformation of the tube wall. There are no sharp edges or notches to reduce the vibration resistance.
13. **Superior mechanical strength** – The working contact area of the EO2-FORM connection is the flat front surface of the metal support ring which is made of heat-treated, high-strength steel or stainless steel. This provides superior mechanical strength without settling, loosening or need for re-tightening.
14. **Universal** – The WorkCenter can cold-form all common steel and stainless steel tube materials for hydraulic pipework. Even exotic materials such as Cu-NiFe or Duplex can be formed. The tools cover metric tube sizes from 6 to 42 mm OD.
15. **Short tube ends** – The compact clamping device and special dies are suitable for machining complex tube bends.
16. **Noise/energy loss reduction** – The process results in a smooth inner contour of the tube. Minimum pressure drop, heat and noise is created. No hidden corners allow the accumulation of air, dirt or other sources of trouble.
17. **Clean** – The process is environmental clean and safe. As no heat is used, hazards from fumes or heat do not occur.
18. **Zinc plated tubing** – The process allows the use of zinc-plated tubing. The costs of cleaning or painting are saved.
19. **Quality** – Tube clamping and tool functions are fully automated. Proper joint geometry and seal dimensions are achieved by using standard EO-2 sealing rings. Therefore high and consistent quality is achieved without manual adjustment.
20. **Proven Technology** – Since 1993, millions of EO-2 fittings have operated worldwide under heavy duty conditions, providing leak-free hydraulic systems.
21. **No restrictions** – The process allows to use EO-2 elastomeric sealing technology even for applications where bite-type connectors are not permitted by safety standards, for example hydraulic presses, cranes, lifts or ship canal systems locks.



Assembly tooling

WorkCenter for EO2-FORM high pressure tube connections

Machine Type	Order code F3	Order code PRO22	Order code EO-KARRYFORM
WorkCenter basic unit for forming tube ends, ready to operate with magnetic gripper, holder and operator's handbook, but without tools, packed in a special transportation box			
Universal F3 WorkCenter Tube OD 6–38/42 mm 400 V, 50 Hz, 3 phase 230 V, 50 Hz, 3 phase 440 V, 60 Hz, 3 phase Rental (monthly usage) Leasing (24 leasing rate)	EO2FORMF3400V EO2FORMF3230V EO2FORMF3440V EO2FORMF3RENTFEE EO2FORMF3LEASEFEE	EO2FORM400VPRO EO2FORMPRORENTFEE EO2FORMPROLEASEFEE	
Mobile transportable device Tube OD 6–38/42 mm 230 V, 50 Hz, 1 phase Rental (monthly usage) Leasing (24 leasing rate)			EOKARRYFORM230V EOKARRYFORMRENTFEE EOKARRYFORMLEASEFEE
Accessories Type	Order code F3	Order code PRO22	Order code EO-KARRYFORM
Lubrication for forming pin: EO-NIROMONT Liquid lubricant in a brush-in-cap (250 cc) 0.25 L bottle EO-NIROMONT 1L re-fill pack EO-NIROMONT	EONIROMONTAPPLICATOR EONIROMONTFLUCESSX LUBSS	EONIROMONTAPPLICATOR EONIROMONTFLUCESSX LUBSS	EONIROMONTAPPLICATOR EONIROMONTFLUCESSX LUBSS
Oil cooler kit	F3/COOLERKIT	included	—
Foot switch	F3/FOOTSWITCH	F3/FOOTSWITCH	F3/FOOTSWITCH
Magnetic gripper for forming pin	F3/PINHOLDER	F3/PINHOLDER	F3/PINHOLDER
Holder for forming die set	F3/DIEHOLDER	F3/DIEHOLDER	F3/DIEHOLDER
Clamping segments for die set	F3/DIECLAMP	F3/DIECLAMP	F3/DIECLAMP
Clamping segment spring Ø 8 mm	F3/DIECLAMPSPRING8	F3/DIECLAMPSPRING8	F3/DIECLAMPSPRING8
Clamping segment spring Ø 12 mm	F3/DIECLAMPSPRING12	F3/DIECLAMPSPRING12	F3/DIECLAMPSPRING12
Operation manual: UK, DE, FR, IT, SWE	4033	EO2FORMPRO/MANUAL	4034
Standard preventive maintenance	EO2FORMF3/INSPECTION	EO2FORMF3/INSPECTION	EOKARRYFORM/INSPECTION

WorkCenter are shipped in special containers which should be kept for future transports to avoid damage. Please don't dispose the transport boxes!

Machine housing Type	Order code F3	Order code PRO22	Order code EO-KARRYFORM
Top machine cover	F3/HEADCOVER	F3PRO/08836014	—
Top tray	F3/TOPTRAY	F3/TOPTRAY	—
Door lock for tool compartment	F3/DOORLOCK	F3/DOORLOCK	—
Door hinge	F3/DOORHINGE	F3/DOORHINGE	—
Shock absorber for doors	F3/DOORSRING	F3/DOORSRING	—
Tool tray for inner tool compartment (top), 6x	F3/TOOLTRAYIN	F3/TOOLTRAYIN	—
Tool tray for inner tool compartment (bottom), 6x	F3/0883611	F3/0883611	—
Tool tray for tool compartment in doors, 2x	F3/TOOLTRAYDOOR	F3/TOOLTRAYDOOR	—
Die insert for tool tray (use screw M6)	F3/TOOLTRAYPIN	F3/TOOLTRAYPIN	—
Holder for magnetic gripper	F3/PINHOLDERTRAY	F3/PINHOLDERTRAY	—
Holder for holder	F3/DIEHOLDERTRAY	F3/DIEHOLDERTRAY	—
Plastic guide for forklift (use screw M6)	F3/FORKGUIDE	F3/FORKGUIDE	—
Front wheel with lock	F3/FRONTWHEEL	F3/FRONTWHEEL	—
Rear wheel	F3/BACKWHEEL	F3/BACKWHEEL	—

Sticker Type	Order code F3	Order code PRO22	Order code EO-KARRYFORM
Door label	F3/STICKERPARKER	F3PRO/STICKERPARKER	—
Short instructions on side	F3/STICKERINSTRUC	F3PRO/STICKERINSTRUC	—
Lubrication on front	F3/STICKERLUB	F3/STICKERLUB	—
Crane attachment (1 piece)	F3/STICKERCRANE	F3/STICKERCRANE	—
Forklift on front	F3/STICKERFORK	F3/STICKERFORK	—

Operation panel Type	Order code F3	Order code PRO22	Order code EO-KARRYFORM
Front panel counter	F3/FRONTCOUNTER	F3/FRONTCOUNTER	—
“START” switch (black with symbol)	F3/STARTSWITCH	F3/STARTSWITCH	—
“RESET” switch (blue)	F3/RESETSWITCH	F3/RESETSWITCH	—
“ON” switch (green)	F3/ONSWITCH	F3/ONSWITCH	—
“OFF” switch (red)	F3/OFFSWITCH	F3/OFFSWITCH	—
Emergency stop switch (red)	F3/STOPSWITCH	F3/STOPSWITCH	—

Tool Components Type	Order code F3	Order code PRO22	Order code EO-KARRYFORM
Bayonet bolt for forming pin	F2/PINBOLT	F2/PINBOLT	F2/PINBOLT
Screw for clamping die segments	F3/DIESCREW	F3/DIESCREW	F3/DIESCREW
Spare part kit for clamping die set (4x Pin Ø4, 4x Spring Ø8, 4x Spring Ø12, 4x Screws)	F3/DIEKIT	F3/DIEKIT	F3/DIEKIT



WorkCenter for EO2-FORM high pressure tube connections

Clamping die set MF3EO2			Forming pin BF3EO2		
Tube O.D. Ø	Clamping dies for steel tubes Order code	Clamping dies for stainless steel tubes Order code	Ø x s	Forming pin for steel tubes Order code	Forming pin for stainless steel tubes Order code ¹⁾²⁾
06-L/S	MF3EO2P306	MF3EO2P306	06x1.0 06x1.5 06x2.0	BF3EO206X1S BF3EO206X1.5S BF3EO206X2S	BF3EO206X1SS BF3EO206X1.5SS
08-L/S	MF3EO2P308	MF3EO2P308	08x1.0 08x1.5 08x2.0 08x2.5	BF3EO208X1S BF3EO208X1.5S BF3EO208X2S BF3EO208X2.5S	BF3EO208X1SS BF3EO208X1.5SS
10-L	MF3EO2P310	MF3EO2P310	10x1.0 10x1.5 10x2.0	BF3EO210LX1S BF3EO210LX1.5S BF3EO210LX2S	BF3EO210LX1SS BF3EO210LX1.5SS BF3EO210LX2SS
10-S	MF3EO2P310	MF3EO2P310	10x1.5 10x2.0 10x3.0	BF3EO210SX1.5S BF3EO210SX2S BF3EO210SX3S	BF3EO210SX1.5SS BF3EO210SX2SS
12-L	MF3EO2P312	MF3EO2P312	12x1.5 12x2.0	BF3EO212LX1.5S BF3EO212LX2S	BF3EO212LX1.5SS BF3EO212LX2SS
12-S	MF3EO2P312	MF3EO2P312	12x1.5 12x2.0 12x3.0	BF3EO212SX1.5S BF3EO212SX2S BF3EO212SX3S	BF3EO212SX1.5SS BF3EO212SX2SS
15-L	MF3EO2P315	MF3EO2P315	15x1.0 15x1.5 15x2.0	BF3EO215X1S BF3EO215X1.5S BF3EO215X2S	BF3EO215X1.5SS BF3EO215X2SS
16-S	MF3EO2P316	MF3EO2P316SS	16x2.0 16x2.5 16x3.0	BF3EO216X2S BF3EO216X2.5S BF3EO216X3S	BF3EO216X2SS BF3EO216X2.5SS BF3EO216X3SS

Assembly tooling

WorkCenter for EO2-FORM high pressure tube connections

Tube O.D. Ø	Clamping dies for steel tubes Order code	Clamping dies for stainless steel tubes Order code	Ø × s	Forming pin for steel tubes Order code	Forming pin for stainless steel tubes Order code ¹⁾²⁾
18-L	MF3EO2P318	MF3EO2P318SS	18×1.5 18×2.0	BF3EO218X1.5S BF3EO218X2S	BF3EO218X1.5SS BF3EO218X2SS
20-S	MF3EO2P320	MF3EO2P320SS	20×2.0 20×2.5 20×3.0 20×3.5	BF3EO220X2S BF3EO220X2.5S BF3EO220X3S BF3EO220X3.5S	BF3EO220X2SS BF3EO220X2.5SS BF3EO220X3SS BF3EO220X3.5SS
22-L	MF3EO2P322	MF3EO2P322SS	22×1.5 22×2.0	BF3EO222X1.5S BF3EO222X2S	BF3EO222X1.5SS BF3EO222X2SS
25-S	MF3EO2P325	MF3EO2P325SS	25×2.0 25×2.5 25×3.0 25×4.0	BF3EO225X2S BF3EO225X2.5S BF3EO225X3S BF3EO225X4S	BF3EO225X2SS BF3EO225X2.5SS BF3EO225X3SS BF3EO225X3.5SS
28-L	MF3EO2P328	MF3EO2P328SS	28×2.0 28×2.5 28×3.0	BF3EO228X2S BF3EO228X2.5S BF3EO228X3S	BF3EO228X2SS BF3EO228X2.5SS
30-S	MF3EO2P330	MF3EO2P330SS	30×2.5 30×3.0 30×4.0 30×5.0	BF3EO230X3S BF3EO230X4S BF3EO230X5S	BF3EO230X3SS BF3EO230X4SS BF3EO230X5SS
35-L	MF3EO2P335	MF3EO2P335SS	35×2.0 35×2.5 35×3.0	BF3EO235X2S BF3EO235X3S	BF3EO235X2SS BF3EO235X2.5SS BF3EO235X3SS
38-S	MF3EO2P338	MF3EO2P338SS	38×3.0 38×4.0 38×5.0 38×6/7	BF3EO238X3S BF3EO238X4S BF3EO238X5S BF3EO238X6+7S	BF3EO238X3SS BF3EO238X4SS BF3EO238X5SS BF3EO238X6SS
42-L	MF3EO2P342	MF3EO2P342SS	42×2.0 42×3.0	BF3EO242X2S BF3EO242X3S	BF3EO242X2SS BF3EO242X3SS

Tools for hose connection DIN 71550

Tube O.D. Ø	Clamping dies for steel and stainless steel tubes Order code	Ø × s	Forming pin for steel tubes Order code	Forming pin for stainless steel tubes Order code ¹⁾²⁾
10	MF3EO2P310	10×1.5	BF3DIN7155010X1.5S	
12	MF3EO2P312	12×1.5	BF3DIN7155012X1.5S	BF3DIN7155012X1.5SS
15	MF3EO2P315	15×2.0	BF3DIN7155015X2S	
18	MF3EO2P318	18×1.5	BF3DIN7155018X1.5S	
20	MF3EO2P320	20×2.5	BF3DIN7155020X2.5S	
22	MF3EO2P322	22×1.5	BF3DIN7155022X1.5S	BF3DIN7155022X1.5SS
25	MF3EO2P325	25×2.0	BF3DIN7155025X2S	BF3DIN7155025X2SS
28	MF3EO2P328	28×1.5 28×2.0	BF3DIN7155028X1.5S	BF3DIN7155028X1.5SS BF3DIN7155028X2SS
30	MF3EO2P330	30×1.5		BF3DIN7155030X1.5SS
32	MF3EO2P332	32×1.5	BF3DIN7155032X1.5S	
35	MF3EO2P335	35×2.0		BF3DIN7155035X2SS

Tool compatibility:

Italic = Tools for EO2-FORM F3 WorkCenter

Regular = Tools for EO2-FORM F3 and PRO22 WorkCenter

Tool lifetime

Assembly tools are subject of wear and must be regularly (max. 50 assemblies) cleaned and checked (Checking instructions see chapter E). Worn out tools can cause dangerous assembly failures and must be replaced in time. Maximum lifetime can be achieved by following factors:

Please select clamping die and forming pin according to tube dimension and material.

- All forming pins for stainless steel tubing are marked with a blue dot on front surface.
 - Stainless steel tools are TiN coated.
Clamping die sets which are only used for stainless steel tubes should be marked with the blue dot sticker to avoid use with steel tube.
- Regular cleaning and checking
 - Clean and corrosion-protected storage
 - Proper de-burring and cleaning of tube end
 - Proper tool selection and operation
 - Use of specified lubricant

Flaring tools for Triple-Lok® tubes

Flaring tool selection guide





Manual flaring devices are available for on-site assembly and field repair of Triple-Lok® tube connections.

Manual flaring tools range from simple impact flarers to handpump-operated workshop devices. Flaring result and fitting performance depends strongly on the skill and effort of operator. Hand flaring tools are not recommended for efficient industrial production.

Features, advantages and benefits of hand flaring tools

- 1. Flexible** – Manual flaring tools are portable and do not need any power supply. Therefore they are ideal for on-site assembly and field repair.
- 2. Special** – Each device has been especially developed to match Parker Triple-Lok® standards. The tube connections will fit properly without rework.

How to select the ideal flaring device for your application:

	Hand flaring tools 1004/210A	Impact flaring tool	KARRYFLARE	Parflare ECO
				
Assembly method Triple-Lok® O-Lok®	impact flaring not suitable	impact flaring not suitable	conventional flaring not suitable	conventional flaring not suitable
Tube specification Material	copper, steel	copper, steel, stainless steel	steel, stainless steel	steel, stainless steel
Dimension metric tube	6 to 16 mm (1004)	6 to 38/42 mm	6 to 38/42 mm	6 to 38/42 mm
Dimension inch tube	1/8" to 5/8" (210A)	1/4" to 1 1/2"	1/4" to 1 1/2"	1/4" to 1 1/2"
Min. U-bend	depending on vice	depending on vice	65 mm	70 mm
Tools Clamping dies Flaring pin	one device integral part of device	vice block pin plus hammer	Flaring die M15 ... (same dies used EOMAT) integral part of device	Flaring die M15 ... (same dies used EOMAT) integral part of device
Operation Flaring Process control Tube clamping	hammer impact manual manual clamping	hammer impact manual manual	handpump pressure according to chart automatic clamping	electro-hydraulic pressure according to chart automatic clamping
Specifications Design Weight Dimension (WxLxH)	flaring device for use in vice approx. 1.5 kg –	Hand tools for use in vice – –	portable desktop approx. 29 kg 750x360x260 mm	portable desktop approx. 30 kg 750x360x300 mm
Performance Overall cycle time Economic production quantity: Quality	approx. 1–3 min 10 flarings per week dependant on operator	approx. 1–3 min 10 flarings per week dependant on operator	approx. 30–60 sec. max. 50 flarings per day controlled process	approx. 15–20 sec. max. 100 flarings per day controlled process
Application	on-site repair jobs only; Limited to small dimensions. Limited to single assemblies, not for industrial production, emergency repairs until industrial flared tube is available for replacement.		Efficient for on-site flaring of small quantities not for mass production	portable machine for repair and workshop



Manual flaring tools for Triple-Lok® tubes

These 37° flaring tools are for use with copper, aluminum alloy, and thin wall steel or stainless steel tubes. A vice block is clamped together with the tube end into a vice. Flaring pin is used with a hammer. Separate tooling sets for each tube size in metric and inch dimensions are available.

These hand tools are suitable for small on-site repair jobs. They are not suitable for thick-wall tubing and industrial production. A rigid vice must be available at the assembly site.

Features, advantages and benefits

1. **Light** – Hand flaring tools can be used at any assembly site where a proper workshop is not available
2. **Quick** – Hand flaring tools can be used for temporary repair until a proper spare tube has been made by machine

Applications

- Field repair of agricultural and construction vehicles
- Small, local repair workshops
- Mobile repair service

Combination impact flarer 1004 for small dimension metric tube

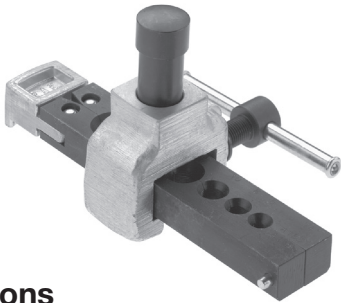

Specifications

- Design:** Hand flaring tool for small on-site repair jobs
- Operation:** Flaring pin Impact
- 37° Flaring: Triple-Lok® connection – ISO 8434-2/ SAE J514
- Tube material: copper, aluminum and low carbon steel
- Tube diameter: 6 to 16 mm metric tube
- Wall thickness: max 15% of tube O.D.
- Requirements: Rigid vice and hammer
- Performance: Overall cycle time 1–3 min
- Economic production quantity: 10 flarings per week

Operation

1. Clamp tube end flush in block halves
2. Clean and lubricate tube end and flaring pin
3. Form the flare by a few sharp hammer blows
4. Release vice and unclamp tube

See chapter E for detailed instructions on Triple-Lok® assembly

Ordering

Type	Order code
Combination impact flarer Complete device including Combination dies and pin	1004-74M
EO-NIROMONT Liquid lubricant in a brush-in-cap can (250 cc)	EONIROMONTAPPLICATOR

Impact flaring tools for metric and inch tube

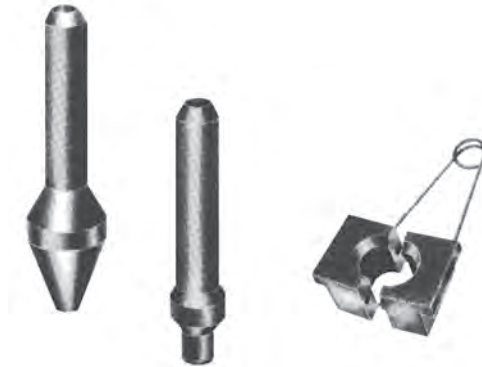

Specifications

- Design:** Hand flaring tools for small on-site repair jobs
- Operation:** Impact flaring pin
- 37° Flaring:** Triple-Lok® connection – ISO 8434-2/ SAE J514
- Tube material:** copper, aluminum, steel and stainless steel tube
- Tube diameter:** 6 to 38 mm/1/4" to 1 1/2"
- Wall thickness:** max 15% of tube-O.D., max 10% of tube O.D. for tubes larger 20 mm tube O.D.
- Requirements:** Rigid vice and hammer
- Performance:** Overall cycle time 1–3 min
- Economic production quantity:** 10 flarings per week

Operation

1. Clamp tube end flush in block halves
2. Clean and lubricate tube end and flaring pin
3. Form the flare by a few sharp hammer blows
4. Use pre-flaring pin for tube O.D. 20 mm/3/4" and larger
5. Release vice and unclamp tube

See chapter E for detailed instructions on Triple-Lok® assembly



Tools for metric tube			
Tube-O.D. mm	Pre-flaring pin Order code	Flaring Order code	Vice block Order code
06		P17408	M27406
08		P17408	M05742
10		P17408	M27410
12		P17414	M27412
14		P17414	M27414
15		P17414	M27415
16		P17414	M27416
18		P17418	M27418
20	P1E	P17418	M27420
22	P1E	P17422	M14742
25	P1E	P17422	M27425
30	P1E	P17432	M27430
32	P1E	P17432	M27432
38	P1E	P17438	M24742

Tools for inch tube			
Tube-O.D. inch	Pre-flaring pin Order code	Flaring Order code	Vice block Order code
1/4"		P17408	M04742
5/16"		P17408	M05742
3/8"		P17408	M06742
1/2"		P17414	M08742
5/8"		P17414	M10742
3/4"	P1E	P17418	M12742
7/8"	P1E	P17422	M14742
1"	P1E	P17422	M16742
1 1/4"	P1E	P17432	M20742
1 1/2"	P1E	P17438	M24742

Type	Order code
Tool lubricant 0.25L bottle	EONIROMONTFLUESSX

KARRYFLARE Portable flaring device for Triple-Lok®

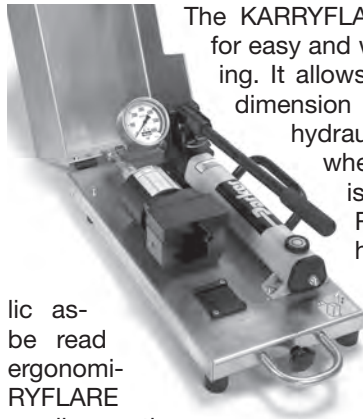

The KARRYFLARE is a portable device for easy and workmanlike 37° tube flaring. It allows the flaring of even large dimension steel and stainless steel hydraulic tube at assembly sites where Parflange® technology is not available. The KARRYFLARE consists of a hydraulic flaring unit and a hand pump. The hydraulic assembly pressure can be read on a gauge which is ergonomically located. The KARRYFLARE is ideal for tube flaring of small quantities and on-site tube installation.

lic as-
be read
ergonomi-
RYFLARE
small quanti-
stallation.

It is practical, simple to operate, reliable and easy to transport. The KARRYFLARE comes as one unit with all components firmly attached to a practical carrying frame.

Technical data

Application: 37° flaring of hydraulic tube
Flare dimensions and geometry according to ISO 8434 / SAE J514
For Parker Triple-Lok® hydraulic fittings
Tube outer diameter: 6 to 38 mm / ¼ to 1 ½"
Maximum capacity: 38 x 4 mm / 1 ½ x 0.120"
With special flaring pin up to 42 mm tube O.D.
Tube material: steel and stainless steel
Minimum width U-bend: 70 mm
Weight: approx. 29 kg
Dimensions: approx. L 750 mm x W 360 mm x H 260 mm
Hydraulic oil: H-LP32-1.2 liter

Ordering

KARRYFLARE device and accessories

Description	Order code
KARRYFLARE Manual flaring device KarryFlare including handpump, carrying case and manual tank filled with hydraulic oil, 37° flaring pin installed. Flaring dies "M15" must be ordered separately.	KARRYFLARE
Accessoires	
Tool lubricant 0.25L bottle	EONIROMONTFLUCESSX
EO-NIROMONT Liquid lubricant in a brush-in-cap can (250 cc)	EONIROMONTAPPLICATOR
Promotion leaflet	LEAF/4049-D1/UK/DE
Spare parts	
Flaring bloc, complete	KARRYFLARE/BLOC
Standard Flaring pin 6-38 mm, with O-ring	KARRYFLARE/FPIN
Special Flaring pin 42 mm, with O-ring	KARRYFLARE/FPIN42
Tube stop with guide	KARRYFLARE/TSTOPKPL
Pressure chart sticker	KARRYFLARE/CHART

Performance

Cycle time: 30-60 sec.
Economic production quantity: max 50 flarings per day

Features, advantages and benefits

1. Flexible on-site tube flaring
2. Simple operation
3. KARRYFLARE is portable and does not require any power supply
4. Flaring quality is comparable to EOMAT
5. Saves time and effort compared to manual impact flaring
6. Safe and consistent result
7. All elements are ergonomically located
8. Robust, light metal transport box
9. Telescopic handle and wheels for convenient trolley transport
10. Uses "M15" flaring dies (EOMAT/1015)

Applications

- Assembly of 37° flare fittings in small quantities
- On-site repair of agricultural vehicles and mobile construction equipment
- Repair workshops and plant maintenance
- Mobile repair service

KARRYFLARE		
 Tube-O.D. Ø [mm] - Ø [Inch]		 Triple-Lok®, P [bar]
6	1/4	35
8	5/16	45
10	3/8	60
12	1/2	60
14		80
15		100
16	5/8	100
18		120
20	3/4	160
22		160
25	1	180
28		215
30	1 1/4	230
35		270
38	1 1/2	280
42		320

Parflare ECO

Mobile flaring machine for Triple-Lok® hydraulic fittings



Parflare ECO
Economical – Simple – Safe

A full fledged Triple-Lok® fitting flaring machine at an economical price. The Parflare ECO is a mobile machine that flares tubes to 37° for Parker Triple-Lok® hydraulic fittings. This electro-hydraulic machine is simple to operate, with the flaring pressure being set via a digital display. The machine is simple to use, rugged and easy to transport. Because of these features, the Parflare ECO is the ideal machine for hydraulic service technicians.

Application areas:

For the repair and maintenance of hydraulic tubing systems in both workshop and field operations.

Advantages for the service technician:

- professional flaring
- energy and time savings due to the electric drive
- simple operation
- portable and light
- rugged and mobile

Purchasing advantages:

- inexpensive
- economical mode of operation
- existing tooling can be used
- unbeatable price-to-performance ratio

The machine is perfectly suited to regular use, but not to high volume production.

Technical Data	
Application:	Flaring tubes for Parker Triple-Lok® hydraulic connectors
Procedure:	Axial forming with flaring pin
Flaring:	37° to DIN EN ISO 8434-2
Tube material:	Steel and stainless steel tubing
Tube diameter:	6 to 42 mm / ¼" to 1 ½"
Minimum width U-bend:	70 mm
Speed:	15 to 20 sec. cycle time/approx. 20 to 30 sec. total cycle time
Economical production quantity:	max. 100 assemblies per day
Dimensions (LxWxH):	750x300x360 mm
Weight:	30 kg
Continuous operating	50 %
Electrical power rating:	EU Version: 230 V single phase 50 Hz 700 W US Version: 110 V single phase 60 Hz 700 W

Type	Order code
Parflare ECO basic machine, ready to operate, including operator's handbook, KARRYFLARE/FPIN installed, "M15" flaring dies must be ordered separately	EU Version: PARFLAREECO230V US Version: PARFLAREECO110V
Brochure	BUL/4048/DE via Parker catalogue Service EMDC
Operator's handbook UK/DE/FR/IT/ES	PARFLAREECO/MANUAL
Standard preventive maintenance	PARFLAREECO/INSP
Pressure chart sticker	PARFLAREECO/CHART
Standard flaring pin 6–38 mm, with O-ring	KARRYFLARE/FPIN
Special flaring pin 42 mm, with O-ring	KARRYFLARE/FPIN42

Operation:

For detailed assembly instructions, see our fittings technology handbook, chapter E. For safety information, see machine operating manual.

1. Insert die valves and close cover
2. Set the recommended flaring pressure in accordance with the chart on the display
3. Insert tube with retaining nut and sleeve
4. Push START button and keep depressed
5. Keep a firm hold of the tube throughout the complete flaring procedure
6. The flaring procedure is finished when the cylinder has returned back to its start position
7. Flaring inspection and final assembly should be in accordance with the assembly handbook





Tool lifetime

Assembly tools are subject to wear and must be regularly (max. 50 assemblies) cleaned and checked (Checking instructions see chapter E). Worn out tools can cause dangerous assembly failures and must be replaced in time. Maximum lifetime can be achieved by following factors:

- Regular cleaning and checking
- Clean and corrosion-protected storage
- Proper de-burring and cleaning of tube end
- Proper tool selection and operation
- Use of specified lubricant

Parflare ECO mobile flaring machine for Triple-Lok® hydraulic fittings

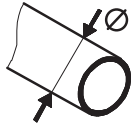
Pressure chart

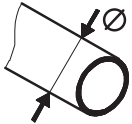
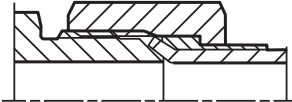
 Parflare ECO 		
 Tube-O.D.  Ø (mm)	 Tube-O.D.  Ø (inch)	Triple-Lok®  P (bar)
6	1/4	20
8	5/16	25
10	3/8	35
12	1/2	35
14		45
15		60
16	5/8	60
18	3/4	70
20		95
22	1	95
25	1 1/4	110
28		130
30	1 1/2	140
35		165
38		180
42		200

37° flaring tools for KARRYFLARE device and PARFLARE ECO, EOMAT UNI, II and III

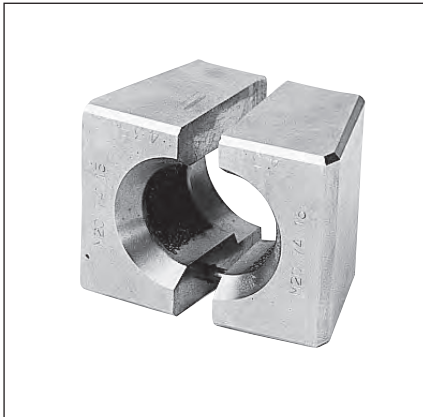

Flaring die set M1574

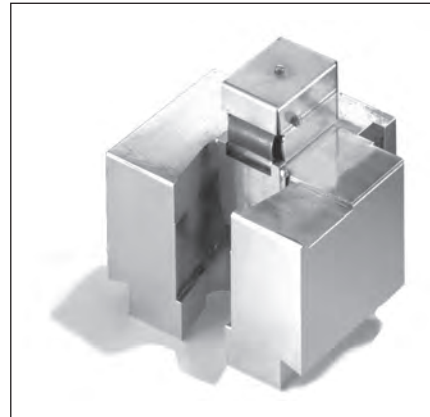

Flaring fixture must be installed on EOMAT UNI II/III

Flaring dies for metric tube	
Tube O.D. mm	Order code
6	M157406-1
8	M157408-1
10	M157410-1
12	M157412
14	M157414
15	M157415
16	M157416
18	M157418
20	M157420
22	M157422
25	M157425
28	M157428
30	M157430
32	M157432
35	M157435
38	M157438
38x6	
42	M157442

Flaring dies for inch tube	
Tube O.D. inch	Order code
3/16"	M037415-1
1/4"	M047415-1
5/16"	M157408-1
3/8"	M067415-1
1/2"	M087415
5/8"	M107415
3/4"	M127415
7/8"	M147415
1"	M167415
1 1/4"	M207415
1 1/2"	M157438

Flaring diameters acc. to ISO 8434-2/SAE J514 for Triple-Lok®. Not suitable for metric flare adapters.

The flaring pin for the KARRYFLARE and Parflare ECO is integrated in the device. For the EOMAT UNI the flaring pins are in the EOMAT flaring fixture (EOMATBOERDELBX).

Flaring dies are **not** interchangeable with Parflange® tools for 1025/1040/50-machines.

Tool lifetime

Assembly tools are subject of wear and must be regularly (max. 50 assemblies) cleaned and checked (Checking instructions see chapter E). Worn out tools can cause dangerous assembly failures and must be replaced in time. A Maximum lifetime can be achieved by following factors:

- Regular cleaning and checking
- Clean and corrosion-protected storage
- Proper de-burring and cleaning of tube end
- Proper tool selection and operation
- Use of specified lubricant

Assembly machines for O-Lok® and Triple-Lok®

Parflange® machine selection guide

Parflange® 1025 and Parflange® 50 are orbital flaring machines designed to cold-form high pressure tube connections. The unique feature of the Parflange® process is that the deformation of the tube end is achieved by rolling rather than by just pushing a tool into the tube end. The Parflange® machine smoothly compresses the tube material and achieves a high strength joint with a polished surface of the tube end. O-Lok® sleeves are firmly fixed onto the tube end, resulting in a very rigid high-pressure tube connection.



Features, advantages and benefits

- 1. Superior sealing performance** – The Parflange® process achieves a sealing surface of unique surface quality and mechanical strength.
- 2. Superior vibration resistance** – Unlike conventional flaring, the Parflange® process results in a rigid connection of the O-Lok® sleeve on the tube-end. Parflange®/O-Lok® connections perform much better under reversed bending stress conditions.
- 3. Easy to use** – No programming or adjustments necessary. High quality results are consistently achieved without manual adjustments.
- 4. Cost saving** – Compared to brazing or welding, orbital flanging is much less time consuming. Special tube preparation and finishing are not necessary. Flanging uses only a fraction

of the energy needed for brazing or welding.

- 5. Clean** – The Parflange® process is environmental clean and safe. As no heat or chemicals are used, hazards from fumes or heat do not occur.
- 6. Zinc plated tubing.** The Parflange® process allows the use of zinc-plated tubing. The cost for cleaning, post process plating or painting is saved.
- 7. Process/Product concept** – Parflange® machines are especially designed to match Parker O-Lok® and Triple-Lok® standards. Machine, tools and products are fine-tuned for reliable performance.
- 8. Proven technology** – For more than 10 years, hundreds of Parflange® machines have operated worldwide under heavy duty workshop conditions.

How to select the ideal Parflange® Machine for your application:

Machine selection chart	Parflange® 1025		Parflange® 50	
				
Assembly method Triple-Lok® O-Lok®	Orbital flaring 37° Orbital flanging 90°		Orbital flaring 37° Orbital flanging 90°	
Tube specification Material Dimension metric tube Dimension inch tube Min. U-bend	Steel, Stainless Steel 6 to 25x4 mm (Steel)/25x2,5 mm Stainless Steel O-Lok® ¹⁾ 1/4" to 1"x0.120 (Steel)/1"x0.095 Stainless Steel O-Lok® ¹⁾ 6 mm to 42 mm / 1/4" to 2" Triple-Lok® 140 mm		Steel, Stainless Steel 6 to 50 mm 1/4" to 2" 120 mm	
Tools Clamping dies Flaring/flanging pin	special Parflange® tools M40 ... (old: M30 ...) B30 ...		special Parflange® tools M40 ... B30 ...	
Operation Setting Standard sleeve feeding Optional sleeve feeding Tube clamping Flanging/Flaring Process control	automatic adjustment manual loading not available manual clamping automatic drive semi automatic		automatic adjustment manual loading (BASIC) O-Lok® sleeve feeder (PRO) hydraulic clamping automatic drive fully automatic	
Specifications Design Weight Dimension (LxWxH)	desktop approx. 85 kg 670x390x460 mm		BASIC stand-alone approx. 380 kg 840x700x1035 mm	PRO stand-alone approx. 410 kg 840x700x2030 mm
Performance Version Voltage Overall cycle time Continuous operating Economic production quantity	1.5 kW 400 V 3 Phase approx. 50 secs. 80 % max. 100 per day	1.1 kW 230 V 1 Phase approx. 60 secs. 80 % max. 50 per day	4.5 kW 400 V 3 Phase approx. 15 secs. 100 % max. 500 per day	4.5 kW 400 V 3 Phase approx. 15 secs. 100 % max. 1200 per day
Application	Ideal for projects and workshop use and maintenance High quality result No mass production	on-site repair jobs where 3phase power supply is not available	Efficient production machine for low-cost and high-quality assembly	Efficient mass production machine for low-cost and high-quality assembly

¹⁾ Other sizes on request.

Parflange® 1025 workshop machine for O-Lok® and Triple-Lok®

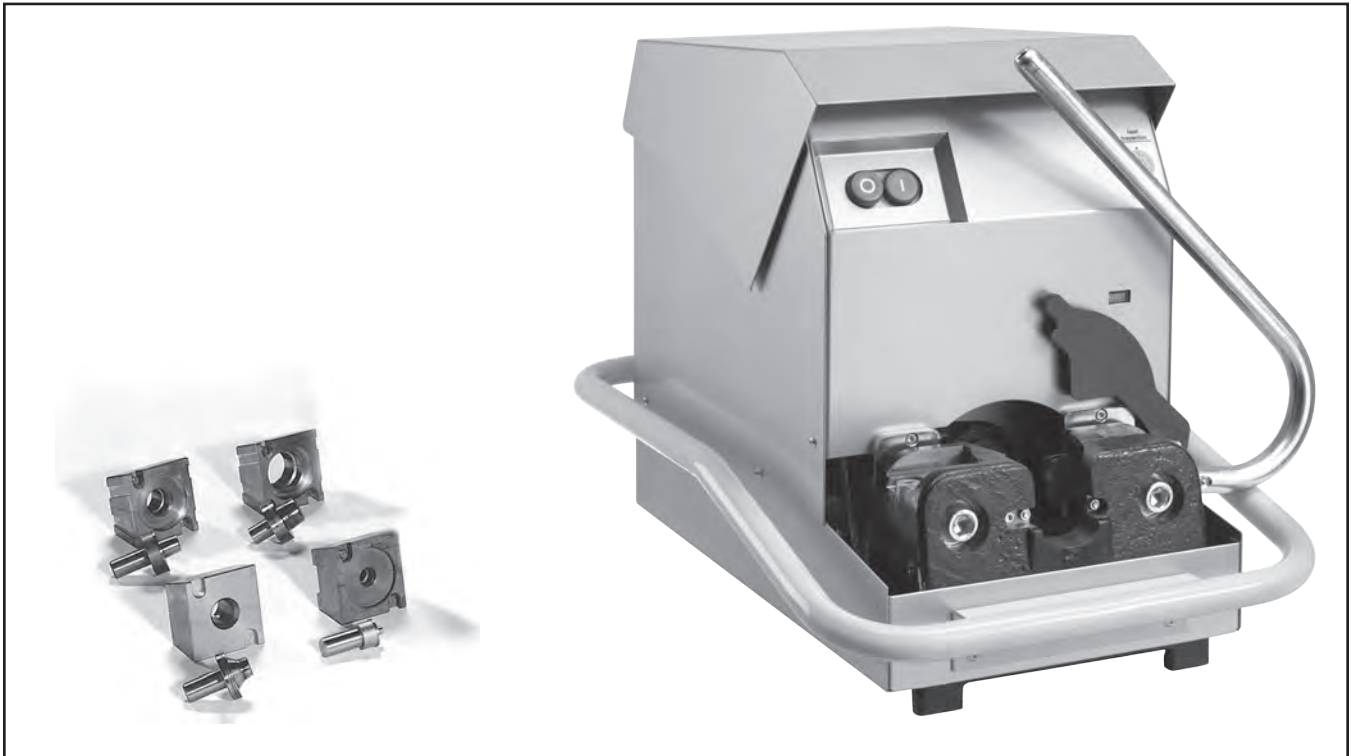

H

The Parflange® 1025 machine is designed to cold-form high pressure tube connections for O-Lok® and Triple-Lok® connection. It uses the Parflange® orbital flaring process. The Parflange® 1025 machine smoothly compresses the tube material and achieves a high strength joint with a polished surface of the tube end. O-Lok® and SAE flange sleeves are firmly fixed onto the tube end, resulting in a very rigid high-pressure tube connection.

The 1025 is the smallest machine of the Parflange® machine programme. It is recommended for low-volume assembly jobs of small to medium tube dimensions. Maximum tube capacity is 25 x 4 mm/1" (steel tube) and 25 x 2.5 mm/1" Parker tube 1.4571 (tube made from other material has to be checked). Its advantage is the quick and easy change of tooling and the simple operation without manual adjustments or programming. The machine is transportable so that it can be moved to any assembly site with electrical power supply.

The Parflange® 1025 comes ready to be used. Parflange® tools are purchased separately. For each tube dimension, special clamping dies and Parflange® pins are required.

Specifications

Purpose: 180° flanging for O-Lok® and 37° flaring for Triple-Lok®
Process: Orbital flaring and flanging according to Parflange® process
Design: Desktop machine for workshop use
Tube material: steel and stainless steel tube
Tube diameter: metric: 6 to 25 mm Inch: ¼ to 1"

Maximum capacity: 6 to 25x4 mm (Steel)/25x2,5 mm Stainless Steel O-Lok®¹⁾
 1/4" to 1"x0.120 (Steel)/1"x0.095 Stainless Steel O-Lok®¹⁾
 6 mm to 42 mm / 1/4" to 2" Triple-Lok®
Min. U-bend: 140 mm
Tube specification: fully annealed seamless cold drawn or welded precision tube
Performance:
Overall cycle time 1.5 kW: 50 sec; 1.1 kW: 60 sec
Economic production quantity 1.5 kW: max. 100; 1.1 kW: max. 50
Operation: Manual clamping, automatic flanging/flaring
Continuous operating: 80 %
Cycle time: approx. 15 to 20 secs.
Tools: Flaring pin B30 or B40 ... and clamping dies M40 ...
Tool clamping: Manual, by eccentric lever
Tool lubrication: Automatic lubrication device
Lubricant: EO-NIROMONT LUBSS (filled when delivered)
Hydraulic oil: HLP 23 0.5L (filled when delivered)
Installation: rigid workbench and electrical power supply required
Dimensions: 670x390x460 mm
Weight: 85 kg

¹⁾ Other sizes on request.

Assembly tooling

Features, advantages and benefits

1. **Superior sealing performance** – The Parflange® process achieves a sealing surface of unique surface quality and mechanical strength.
2. **Superior vibration resistance** – Unlike conventional flaring, the Parflange® process results in a rigid connection of the O-Lok® sleeve on the tube-end. Parflange®/O-Lok® connections perform much better under reversed bending stress conditions.
3. **Easy to use** – No programming or adjustments necessary. High quality results are consistently achieved without manual adjustments.
4. **Quality** – Machine setting, tool control and even lubrication are fully automated so that high and consistent quality results are achieved without manual adjustments.
5. **Small bending radii** – The compact clamping device and special dies are suitable for flanging short tube ends.
6. **Cost saving** – Compared to brazing or welding, orbital flanging is much less time consuming. Special tube preparation and finishing are not necessary. Flanging uses only a fraction of the energy needed for brazing or welding.
7. **Clean** – The Parflange® process is environmental clean and safe. As no heat or chemicals are used, hazards from fumes or heat do not occur.
8. **Zinc plated tubing** – The Parflange® process allows the use of zinc-plated tubing. The cost for cleaning or painting can be saved.
9. **High tool lifetime** – The Parflange® 1025 machine is equipped with an automatic lubrication device. The tools will not wear rapidly if the operator does not lubricate regularly.
10. **Process/Product concept** – Parflange® machines are especially designed to match Parker O-Lok® and Triple-Lok® standards. Machine, tools and products are fine-tuned for reliable performance.
11. **Proven technology** – Since more than 10 years, hundreds of Parflange® machines have operated worldwide under heavy duty workshop conditions.

Applications

Workshop use, project work, plant maintenance, on-site assembly.

Not for efficient mass production

Ordering

Type	Order code
Parflange® 1025 Basic machine Ready to use, Including operating manual, Filled with hydraulic oil and lubricant Without Parflange® tools	
Basic machine 400 V, 3 Phase, 50 Hz	1025-380VTRI50
Basic machine 230 V, 1 Phase, 50 Hz	1025-220VMONO50
Rental (monthly usage)	1025RENTFEE
1025 promotion leaflet UK	4390/UK
1025 promotion leaflet DE	4390/DE
1025 operating manual UK/DE/FR/IT	4390-B5
Standard preventive maintenance	1025/INSPECTION

Parflange® machines are shipped in a special container which should be kept for all transports to avoid damage.

Spare parts

Type	Order code
Tool lubricant qty: 1L EO-NIROMONT	LUBSS
Drive belt	1025/028Polyv
Came guide and with screw	1025/0281031
Hydraulic tank seal kit	1025/0281042
Lubrication kit	1025/0281200
Retrofit Kit: Oilsump for the Parflange 1025 to catch rest lubricant	1025/OILSUMP

Parflange® 50 WorkCenter



Bins can be stored on top platforms



Easy refill of tool lubricant

The Parflange® 50 WorkCenter is the top-of-the-range machine for orbital flaring & flanging of O-Lok® and Triple-Lok® tube assemblies. It combines the practical EO2-FORM F3 WorkCenter concept with the proven Parflange® technology.

Due to the robust design and the precise process control, the Parflange® 50 WorkCenter achieves consistent high quality results and high productivity. Machine housing, cycle programming and all operating elements are designed for good ergonomics, optimum workflow and highest security. The compact Parflange unit and the compact housing allow the forming of small and complex tube bends. Maximum tool lifetime is achieved by the automatic lubrication system as well as easy visibility and accessibility of the tooling area. The integrated tool compartments and designated space for bins for nuts and sleeves make it comfortable and efficient to work with the Parflange® 50.

Parflange® advantages over brazing or welding

Faster and lower cost – 9 to 12 times the speed of comparable induction brazing.

Flexibility – Small batch quantities are practical due to short tool change times.

Simple tube preparation – The Parflange® process does not require any special pre- or post-flange cleaning of the tube and sleeve.

Safety – Unlike brazing, the Parflange® process does not require any flux, braze alloy, post braze cleaner or rust inhibitor. An environmentally safe lubricant applied to the flanging pin is the only additive associated with the Parflange®.

Environment – The Parflange® process is environmentally clean and safe. It does not require open flame or any form of heating. Additionally, there is no emission of hazardous fumes, as is typical with welding and brazing.

Energy – The Parflange® process uses only a fraction of the energy needed for welding or brazing.

Corrosion resistance – The Parflange® process accommodates the use of plated or unplated components (i.e. tube and sleeve). Thus, the high costs of electro-plating assemblies after fabrication is eliminated by using pre-plated tube.

Excellent surface quality – The Parflange® process eliminates the potential leak path present at the braze or weld joint.

Features and benefits

- Cost saving** – Compared to welding or brazing, orbital flanging is much less time consuming. Special tube preparation and finishing are not necessary. Flanging uses only a fraction of the energy needed for brazing or welding.
- Zinc plated tubing** – The Parflange® process allows the use of zinc-plated tubing. The cost for cleaning post process plating, or painting can be saved.
- High tool lifetime** – The Parflange® 50 machine is equipped with an automatic lubrication device. The operator does not have to lubricate the tools ensure long pin life.
- Use of existing tools** – All existing Parflange® tools (M40 dies

and B30/B40 pins) fit into the new machine generation.

- WorkCenter concept** – When the doors are opened, the machine body turns into a WorkCenter for production of O-Lok® and Triple-Lok® tube assemblies. All tools are available for rapid and convenient machine setup and tool change.
- Low-cost mass production** – The machine can be ordered with an automated sleeve feeder. The Parflange® 50 then is the perfect solution for low-cost mass production.
- Universal** – The Parflange® 50 can do 37° flaring for Triple-Lok® connectors and flange tubes for O-Lok® fittings (ORFS). Parflange® tools cover metric tube from 6 to 50 mm O.D. and inch tube from 1/4 to 2" O.D.
- Flange Seal** – The Parflange® 50 is also capable for the innovative Flange Seal connection, which contributes to reduce component cost and assembly time.
- Heavy duty** – The rigid machine design allows use for mass production of even large stainless steel tube connections.
- Process/Product concept** – Parflange® machines are especially designed to match O-Lok®, Triple-Lok® and SAE-flange standards. Machine, tools and products are fine-tuned for reliable performance.
- Superior sealing performance** – The Parflange® process achieves a sealing surface of unique surface quality and mechanical strength.
- Superior vibration resistance** – Unlike conventional flaring, the Parflange® process results in a rigid connection of the O-Lok® sleeve on the tube-end. Parflange®/O-Lok® connections perform much better under reversed bending stress conditions.
- Efficient** – The short cycle time and the automatic process allow efficient mass production.
- Quality** – Tube clamping, tool control and even lubrication is fully automated so that high and consistent quality results are achieved without manual adjustments.
- Easy to use** – The clamping and flanging process is fully automated. Manual tool manipulation is not required. The process is initiated by pushing the tube end into the tooling.
- Bin holder** – The top surface is designed to store two standard bins for fitting nuts and Parflange® sleeves. Everything is easy to reach for the operator.
- Illuminated tooling area** – Insertion of Parflange® sleeves and condition monitoring of tools is easy.
- Practical lubricant refill** – The container for tool lubricant is easily accessible by a hatch on the machine side.
- Side drawer** – Chips, dirt and dropped components like Parflange® sleeves can be removed by a small drawer. This allows to keep the working area clear and avoid jamming of moving parts.
- Clean** – The Parflange® process is environmentally clean and safe. As no heat or chemicals are used, hazards from fumes or heat do not occur.
- Perfect for project work** – After finishing a piping project, the machine can be put aside. Tools don't get lost and dirty. For the next project, the machine just needs to be transported to the new side and unfolded into the WorkCenter. This is particularly useful for piping projects in shipyards, paper mills, offshore platforms or steel mills.
- Ready to go** – The Parflange® WorkCenter is delivered including all necessary details like electrical plug, operator manual, short instruction pictograms on machine housing and dimensional charts for tube preparation.
- New Generation** – The Parflange® 50 WorkCenter replaces the Parflange® 1040 machine, which has been successful in the market for more than 12 years.

Assembly tooling

Parflange® 50 BASIC WorkCenter

Technical description 50 BASIC WorkCenter:

The Parflange® 50 is a production WorkCenter for orbital flaring and flanging of high pressure tube connections. The unique feature of the Parflange® process is that the deformation of the tube end is achieved by rolling rather than by just pushing a tool into the tube end.

The Parflange® machine smoothly compresses the tube material and achieves a high strength joint with a polished surface of the tube end.

O-Lok® sleeves are firmly fixed onto the tube end, resulting in a robust and vibration-resistant tube connection.

The Parflange® 50 is the heavy-duty, mass production WorkCenter of the Parflange® machine programme.

It is recommended for industrial production of all sizes Triple-Lok® and O-Lok® tube connections.

Maximum tube capacity is 50 mm/2" tube O.D.

The powerful drive and the fast, automatic process allow short cycle times for efficient production. Its advantage is the quick and easy change of tooling and the simple operation without manual adjustments or programming. Tube clamping and tool lubrication are done automatically.

The Parflange® 50 comes ready to be used. Parflange® tools have to be purchased separately. For each tube dimension, special clamping dies and Parflange® pins are required. The machine can be moved on wheels, by forklift truck and crane. For basic use, just an electrical power supply is required.



Machine specification 50 BASIC WorkCenter:

Purpose:	90° Flanging for O-Lok® and 37° Flaring for Triple-Lok®	Speed:	5–8 sec. flanging time/15–20 sec. total cycle time
Process:	Orbital flaring and flanging according to Parflange® process	Economic production quantity:	max. 500 flarings per day
Design:	WorkCenter for industrial production	Tools:	Flaring pin B30 ... or B40 ... Clamping dies M40 ...
Tube material:	Steel and stainless steel tube	Tool compartments:	10 die sets, 10 pins
Tube diameter:	Metric: 6 to 50 mm Inch: 1/4" to 2"	Tool clamping:	Automatic
Min. U-bend:	120 mm	Tool lubrication:	Automatic lubrication device
Maximum capacity:	Steel tube (ST 37, ST 52, ...) Metric: 38x5/50x3 mm (tube O.D. x wall thickness) Inch: 2"x0.120 Stainless steel tube (1.4571, 316, ...) Metric: 38x4 mm Inch: 1 1/2"x0.156	Lubricant:	EO-NIROMONT (filled when delivered)
Tube specification:	Fully annealed seamless cold drawn or welded and redrawn precision tube	Hydraulic oil:	HLP 46 (filled when delivered)
Operation:	Automatic clamping, automatic flanging/flaring	Installation:	Electrical power
Continuous operating:	100 %	Dimensions (LxWxH):	840x700x1035 mm
		Platform for bins:	2 platforms, 300x500 mm, max. 5 kg each
		Weight:	380 kg
		Electrical power:	400 V, 3 Phase, 50 Hz, 4.5 kW
		Transport options:	On wheels, by forklift truck, lifting attachments

Parflange® 50 PRO WorkCenter

Technical description 50 Pro WorkCenter:

For industrial mass production of O-Lok® connections, special machines Parflange® 50 PRO with O-Lok® sleeve feeder are available. This sleeve feeding device increases the productivity, particularly of high volume – single tube dimension jobs.

In “Feeder ON – mode”, O-Lok® sleeves just need to be inserted into feeder rails. First cycle start is initiated by manually closing the safety cover. Then, all following cycles are started by pushing the tube into the pre-clamped dies. All other machine activities, like tube clamping, flanging, tube release, insertion of O-Lok® sleeves into dies, pre-clamping of dies and the operation of safety cover run fully automatic. The operator just is handling the tubes and refilling the sleeve-feeder from times to times with O-Lok® sleeves.

In “Feeder OFF – mode”, the Parflange® 50 PRO operates like the Parflange® 50 BASIC without O-Lok® sleeve feeder. This mode is useful for maximum size flexibility and Triple-Lok® assembly. For quick changeover and safety reasons, the O-Lok® sleeve feeder is just switched OFF but not be removed from the Parflange® 50 PRO WorkCenter.

For operation of O-Lok® PRO machines, compressed air supply is required, even when sleeve feeder is not used.



Machine specification 50 PRO WorkCenter:

Specific differences of Parflange® 50 Pro versus Parflange® 50 Basic

Design:	Parflange® 50 with additional O-Lok® sleeve feeder	Feeder:	Feeder is delivered in separate box and must be firmly attached to machine. Feeder can be switched ON and OFF but must not be removed.
Normal Operation:	Same as Parflange® 50 Basic when feeder is switched off	Feeder rails:	Feeder rail kits must be ordered separately for each O-Lok® sleeve size.
Feeder Operation:	Work-cycle is initiated by inserting tube end Automatic clamping, automatic flanging/flaring Automatic insertion of O-Lok® sleeves into dies Automatic operation of safety cover Automatic pre-clamping of dies	Feeder setup:	Installation of matching rail kit by knurled nuts and adjustment of scale wheel according to chart
Manual operation:	like Parflange® 50 Basic	Installation:	Electrical power, for feeder type machines: compressed air supply (6 bar)
Cycle time:	5–8 sec. flanging time/approx. 15 to 20 sec. total cycle time	Dimensions:	700×840×2030 mm
Economic production quantity:	max. 1200 flarings per day	Weight:	410 kg
Tools:	Same tools as Parflange® 50 BASIC		

Assembly tooling

Parflange® 50 Ordering

Type	Order code
Parflange® 50 Basic machine Ready to use, including operation manual, filled with hydraulic oil and lubricant Without Parflange® tools Basis machine Europe version (not prepared for O-Lok® sleeve feeder)	
Purchase: EU-Version US-Version	1050EU400VBASIC 1050US440V60HZBASIC
Leasing (2 year hire purchase)	1050BASICLEASEFEE
Rent (monthly)	1050BASICRENTFEE



Parflange®
50 BASIC

Type	Order code
Parflange® 50 Pro machine Europe version including O-Lok® sleeve feeder without feeder rails	
Purchase: EU-Version US-Version	1050EU400VPRO 1050US440V60HZPRO
Leasing (2 year hire purchase)	1050PROLEASEFEE
Rent (monthly)	not available



Parflange®
50 PRO for mass
production
of O-Lok®
assemblies

Sleeve feeder rails for Parflange® 50 Pro	Tube O.D.	Order code
O-Lok® sleeve feeding rail	6 mm/1/4"	1050/RAIL04
O-Lok® sleeve feeding rail	8, 10 mm/3/8"	1050/RAIL06
O-Lok® sleeve feeding rail	12 mm/1/2"	1050/RAIL08
O-Lok® sleeve feeding rail	14, 15, 16 mm/5/8"	1050/RAIL10
O-Lok® sleeve feeding rail	18, 20 mm/3/4"	1050/RAIL12
O-Lok® sleeve feeding rail	22, 25 mm/1"	1050/RAIL16
O-Lok® sleeve feeding rail	28, 30, 32 mm/1 1/4"	1050/RAIL20
O-Lok® sleeve feeding rail	35, 38 mm/1 1/2"	1050/RAIL24



Feeder rail kits are
available for each
O-Lok® size

50 promotion leaflet	4391-1 via Parker catalogue service EMDC
50 operating manual UK/DE/FR/IT/ES	1050/MANUAL
Standard preventive maintenance	1050/INSPECTION

Tool lubricant refill qty: 1L EO-NIROMONT	LUBSS
Replacement cartridge for spindle lubrication	1050/22900001801



High-Performance lubricant
for Parflange®

Parflange® machines and feeders are shipped in special containers which should be kept for future transports to avoid damage. Please don't dispose the transport boxes!!!

Tooling for Parflange® machines

Machine and tool selection



Parflange® 1025



Parflange® 50

Parflange® 1025 machines flanging capacity for O-Lok®

Tube material	220 V 1.1 kW	380 V 1.5 kW
	Max. tube size mm (inch)	
Steel ST37	25x4 (1"×0.120)	25x4 (1"×0.120)
Stainless steel 304L/316L*	25x2.5 (1"×0.95)	25x2.5 (1"×0.95)
Steel ST52	25x4 (1"×0.120)	25x4 (1"×0.120)

Parflange® 50 machines flanging capacity for O-Lok®

Tube material	Max. tube size mm (inch)
Steel ST37	38x5/50x3 (2×0.120)
Steel ST52	38x4 (1 1/2×0.156)
Stainless steel 304L/316L*	38x4 (1 1/2×0.156)

Parflange® 1025 machines flaring capacity for Triple-Lok®

Tube material	Elect. power of machine	
	220 V 1.1 kW	380 V 1.5 kW
Max. tube size mm (inch)		
Steel ST37	38x4/42x3 (1 1/2×0.120)	38x4/42x3 (1 1/2×0.120)
Steel ST52	38x4/42x3 (1 1/2×0.120)	38x4/42x3 (1 1/2×0.120)
Stainless steel 304L/316L*	38x4/42x3 (1 1/2×0.120)	38x4/42x3 (1 1/2×0.120)
Stainless steel Duplex (or PW 400)	38x3.6	38x3.6

Parflange® 50 machines flaring capacity for Triple-Lok®

Tube material	Elect. power of machine
	220/380 V 4.5 kW
Max. tube size mm (inch)	
Steel TU 37 B	38x4/42x3 (1 1/2×0.120)
Steel TU 52 B	38x4/42x3 (1 1/2×0.120)
Stainless steel 304L/316L*	38x4/42x3 (1 1/2×0.120)
Stainless steel Duplex (or PW 400)	38x3.6

* Parflange® tools for stainless steel tubes have different dimensions and are specially coated. These tools are marked with suffix "SS".

Parflange® tool identification

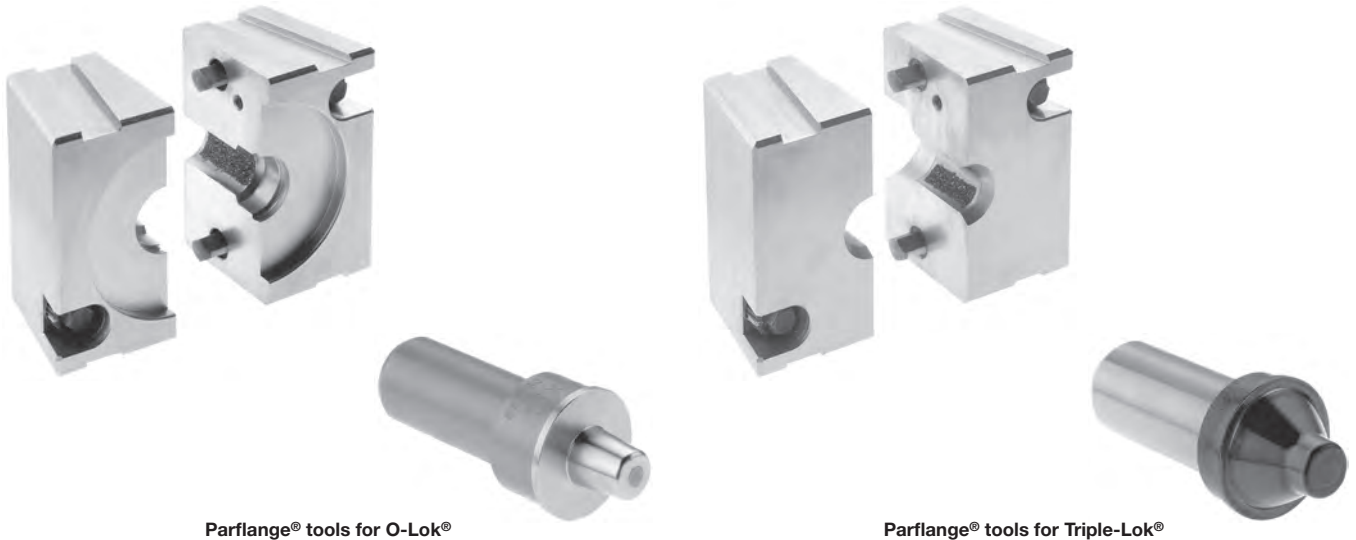

Parflange® tools for O-Lok®

Parflange® tools for Triple-Lok®

Tooling for metric tubing

Metric die numbering system

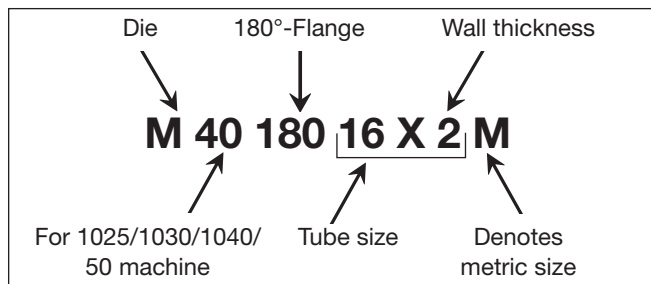

Metric pin numbering system

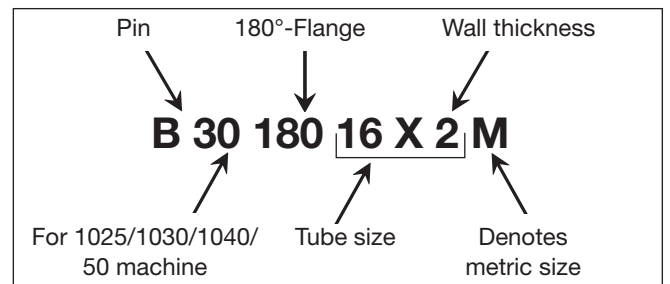

Tooling for inch tubing

Die numbering system

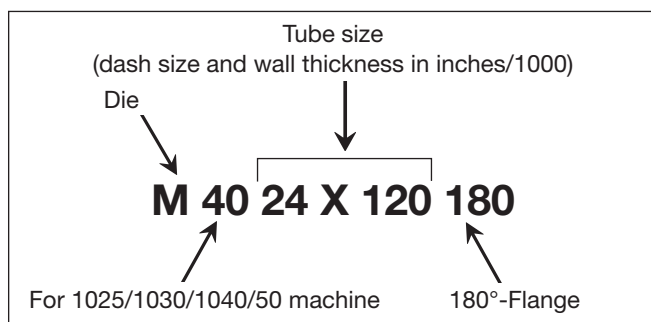

Pin numbering system

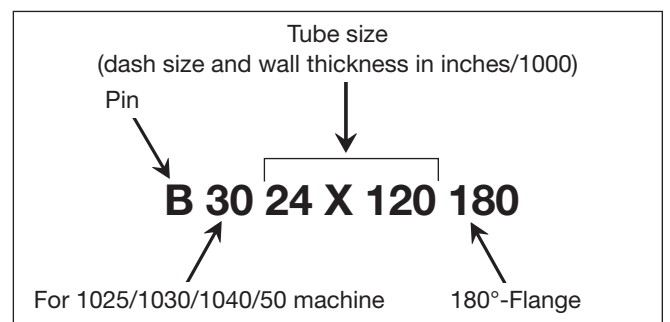

Parflange® tools for stainless steel tubes have different dimensions and are specially coated. These tools are marked with suffix “SS”.

Tool lifetime

Assembly tools are subject of wear and must be regularly (max. 50 assemblies) cleaned and checked (Checking instructions see chapter E). Worn out tools can cause dangerous assembly failures and must be replaced in time. Maximum lifetime can be achieved by following factors:

- Regular cleaning and checking

- Clean and corrosion-protected storage
- Proper de-burring and cleaning of tube end
- Proper tool selection and operation
- Use of specified lubricant

Parflange® tools for O-Lok®

Parflange® tooling – Order codes for Parflange® 50/1040/1030/1025

90°-Flange-tool-selection (Metric tube)

Tube size mm	Steel tube		Stainless steel tube	
	Flange pin Order code	Flange die Order code	Flange pin Order code	Flange die Order code
06×1.0	B3018006X1M	M4018006X1M		
06×1.5	B3018006X1.5M	M4018006X1.5M		
08×1.0	B3018008X1M	M4018008X1M	B3018008X1MSS	M4018008X1MSS
08×1.5	B3018008X1.5M	M4018008X1.5M	B3018008X1.5MSS	M4018008X1.5MSS
10×1.0	B3018010X1M	M4018010X1M	B3018010X1MSS	M4018010X1MSS
10×1.5	B3018010X1.5M	M4018010X1.5M	B3018010X1.5MSS	M4018010X1.5MSS
10×2.0	B3018010X2M	M4018010X2M		
12×1.0	B3018012X1M	M4018012X1M	B3018012X1MSS	M4018012X1MSS
12×1.5	B3018012X1.5M	M4018012X1.5M	B3018012X1.5MSS	M4018012X1.5MSS
12×2.0	B3018012X2M	M4018012X2M		
15×1.0			B3018015X1MSS	M4018015X1MSS
15×1.5	B3018015X1.5M	M4018015X1.5M		
15×2.0	B3018015X2M	M4018015X2M		
16×1.5	B3018016X1.5M	M4018016X1.5M	B3018016X1.5MSS	M4018016X1.5MSS
16×2.0	B3018016X2M	M4018016X2M	B3018016X2MSS	M4018016X2MSS
16×2.5	B3018016X2.5M	M4018016X2.5M		
18×1.5	B3018018X1.5M	M4018018X1.5M		
18×2.0	B3018018X2M	M4018018X2M		
20×2.0	B3018020X2M	M4018020X2M	B3018020X2MSS	M4018020X2MSS
20×2.5	B3018020X2.5M	M4018020X2.5M		
20×3.0	B3018020X3M	M4018020X3M		
22×2.0	B3018022X2M	M4018022X2M		
22×2.5	B3018022X2.5M	M4018022X2.5M		
25×2.5	B3018025X2.5M	M4018025X2.5M	B3018025X2.5MSS	M4018025X2.5MSS
25×3.0	B3018025X3M	M4018025X3M		
28×2.0	B3018028X2M	M4018028X2M		
28×2.5	B3018028X2.5M	M4018028X2.5M		
30×2.0	B3018030X2M	M4018030X2M		
30×3.0	B3018030X3M	M4018030X3M	B3018030X3MSS	M4018030X3MSS
30×4.0	B3018030X4M	M4018030X4M		
32×3.0	B3018032X3M	M4018032X3M		
32×4.0	B3018032X4M	M4018032X4M		
35×3.0	B3018035X3M	M4018035X3M		
38×3.0	B3018038X3M	M4018038X3M		
38×4.0	B3018038X4M	M4018038X4M		

Bold = Standard dimensions
 Regular = Non standard dimensions

Tools for tube dimensions which are not listed must be inquired at Parker.

90°-Flange-tool-selection (Inch tube)

Tube size inch	Steel tube	
	Flange pin Order code	Flange die Order code
1/4×0.035	B3004X035180	M4004X035180
1/4×0.049	B3004X049180	M4004X049180
3/8×0.035	B3006X035180	M4006X035180
3/8×0.049	B3006X049180	M4006X049180
3/8×0.065	B3006X065180	M4006X065180
1/2×0.035	B3008X035180	M4008X035180
1/2×0.049	B3008X049180	M4008X049180
1/2×0.065	B3008X065180	M4008X065180
5/8×0.065	B3010X065180	M4010X065180
5/8×0.083	B3010X083180	M4010X083180
3/4×0.065	B3012X065180	M4012X065180
3/4×0.083	B3012X083180	M4012X083180
3/4×0.095	B3012X095180	M4012X095180
3/4×0.120	B3012X120180	M4012X120180
1×0.065	B3016X065180	M4016X065180
1×0.095	B3016X095180	M4016X095180
1 1/4×0.120	B3020X120180	M4020X120180

Further tools for Inch tubing are available from Parker TFD Columbus!

Tool lifetime

Assembly tools are subject of wear and must be regularly (max. 50 assemblies) cleaned and checked (Checking instructions see chapter E). Worn out tools can cause dangerous assembly failures and must be replaced in time. Maximum lifetime can be achieved by following factors:

- Regular cleaning and checking
- Clean and corrosion-protected storage
- Proper de-burring and cleaning of tube end
- Proper tool selection and operation
- Use of specified lubricant

Assembly tooling

Parflange® tools for Triple-Lok®

Metric tube

Tube size mm	Steel tube		Stainless steel tube	
	Flare pin Order code	Flare die Order code	Flare pin Order code	Flare die Order code
06×1.0 06×1.5	B3007406X1M B3007406X1.5M	M4007406M M4007406M	B3007406X1MSS	M4007406M
08×1.0 08×1.5	B3007408X1M B3007408X1.5M	M4007408M M4007408M	B3007408X1MSS B3007408X1.5MSS	M4007408M M4007408M
10×1.0 10×1.5	B3007410X1M B3007410X1.5M	M4007410M M4007410M	B3007410X1MSS B3007410X1.5MSS	M4007410M M4007410M
12×1.0 12×1.5 12×2.0	B3007412X1M B3007412X1.5M B3007412X2M	M4007412M M4007412M M4007412M	B3007412X1.5MSS	M4007412M
15×1.5 15×2.0	B3007415X1.5M B3007415X2M	M4007415M M4007415M	B3007415X1.5MSS	M4007415M
16×1.5 16×2.0	B3007416X1.5M B3007416X2M	M4007416M M4007416M	B3007416X2MSS	M4007416M
18×1.5 18×2.0	B3007418X1.5M B3007418X2M	M4007418M M4007418M	B3007418X1.5MSS	M4007418M
20×2.0 20×2.5	B3007420X2M B3007420X2.5M	M4007420M M4007420M	B3007420X2MSS B3007420X2.5MSS	M4007420M M4007420M
22×1.5 22×2.0 22×2.5	B3007422X1.5M B3007422X2M B3007422X2.5M	M4007422M M4007422M M4007422M	B3007422X1.5MSS	M4007422M
25×2.5 25×3.0	B3007425X2M B3007425X3M	M4007425M M4007425M	B3007425X2.5MSS	M4007425M
28×2.0 28×2.5	B3007428X2M B3007428X2.5M	M4007428M M4007428M		
30×3.0	B3007430X3M	M4007430M	B3007430X3MSS	M4007430M
32×3.0	B3007432X3M	M4007432M		
35×3.0	B3007435X3M	M4007435M		
38×3.0 38×4.0	B3007438X3M B3007438X4M	M4007438M M4007438M	B3007438X4MSS	M4007438M
42×3.0 42×4.0	B3007442X3M B3007442X4M	M4007442M M4007442M		

Bold = Standard dimensions

Regular = Non standard dimensions

Tools for tube dimensions which are not listed must be inquired at Parker.

Inch tube

Tube size inch	Steel tube	
	Flange pin Order code	Flange die Order code
1/4×0.049	B3004X049074	M4004074
3/8×0.049	B3006X049074	M4006074
3/8×0.065	B3006X065074	M4006074
1/2×0.065	B3008X065074	M4008074
5/8×0.065	B3010X065074	M4010074
5/8×0.095	B3010X095074	M4010074
3/4×0.095	B3012X095074	M4012074
1×0.109	B3016X109074	M4016074
1 1/4×0.120	B3020X120074	M4020074

Further tools for Inch tubing are available from Parker TFD Columbus!

Tool lifetime

Assembly tools are subject of wear and must be regularly (max. 50 assemblies) cleaned and checked (Checking instructions see chapter E). Worn out tools can cause dangerous assembly failures and must be replaced in time. Maximum lifetime can be achieved by following factors:

- Regular cleaning and checking
- Clean and corrosion-protected storage
- Proper de-burring and cleaning of tube end
- Proper tool selection and operation
- Use of specified lubricant

Lubricants

EO-NIROMONT lubricant for fitting assembly

EO-NIROMONT lubricant for flaring and forming tools

EO-NIROMONT are high performance lubricants specifically designed for the assembly of tube connections. They facilitate tightening using a low-torque when assembling joints by hand. In machine assembly, the use of EO-NIROMONT ensures that maximum tool-life is achieved. In forming processes, such as Parflange® or EO2-FORM, smooth and error-free sealing surfaces can be produced. Special additives prevent cold welding when working with stainless steel.

As opposed to when using Parker high performance lubricants, experience shows that the use of standard commercially available lubricants tend to lead to problems such as cold welding of forming tools, particularly when processing stainless steel tube. Parker high performance lubricants – EO-NIROMONT – are offered in different containers and viscosities so that you can purchase the appropriate product in a suitable container to meet your needs:

Liquid lubricant, plastic bottle (item: EONIROMONTFLUOSSX)

Parker high performance lubricant for the lubrication of threads, progressive rings and for all cold forming processes like Parflange® or EO2-FORM. The handy plastic bottle means that it can be applied directly where the lubrication is needed. EO-NIROMONT liquid should always be available at every assembly point where hydraulic connections are being made.

Liquid lubricant, refill package (Item: LUBSS)

Parker high performance lubricant for all cold forming processes like Parflange® or EO2-FORM. Its viscosity means that it is for use in automatic lubrication devices installed in Parflange machines. Absolutely essential for mechanical cold forming of stainless steel tubes.

Paste lubricant, tin (Item: EONIROMONTPASTX)

Parker high performance lubricant for the lubrication of the threads of the pre-assembly tool VOMO. The paste is economical and provides durable thread lubrication. Not suited for use with forming tools, as dust and swarf will stick to it.

Liquid lubricant in a brush-in-cap can (item: EONIROMONTAPPLICATOR)

Thanks to a brush built into the screw cap, the practical EO-NIROMONT APPLICATOR enables the Parker high-performance lubricant to be applied accurately on the component. The plastic bottle can be used to refill the brush-in-cap can practically.

Features, advantages and benefits of NIROMONT lubricant:

- 1. Highly effective** – EO-NIROMONT dramatically reduces assembly effort. This helps to prevent fitting failure resulting from insufficient assembly.
- 2. Cost saving** – Tools in assembly machines will last much longer, resulting in high-quality tube forming with excellent sealing surface.
- 3. No cold welding** – Cold welding of stainless steel threads is impossible when EO-Niromont is properly applied.
- 4. Liquid** – Penetrates even small gaps.
- 5. Paste** – Stays in place for a while. Ideal for application on pre-assembly tools.
- 6. Compatible** – EO-NIROMONT and LUBSS do not effect fitting surfaces or seal materials.

Ordering

Type	Order code
EO-NIROMONT Assembly lubricant paste (100 g e)	EONIROMONTPASTX
EO-NIROMONT Assembly lubricant liquid (250 cc)	EONIROMONTFLUOSSX
EO-NIROMONT Liquid lubricant in a brush-in-cap can (250 cc)	EONIROMONTAPPLICATOR
EO-NIROMONT Forming tool lubricant refill (1 L)	LUBSS



EO-NIROMONT



EO-NIROMONT APPLICATOR



LUBSS



Cutting and bending tools

AV 6/42 – Tube saw square

Provides a neat and quick method of cutting tube at right angles. The exact cut is achieved by hardened guides. We recommend using deeper-section sawblades that cut in both directions for best results. The AV 6/42 can be used in a vice or just be clamped onto the tube for cutting.

Specifications:

Tube. O.D.: 6–42 mm
Weight: approx. 0.7 kg

Type	Order code
Tube cutting tool without saw	AV06/42KPLX
Spare hardened guides	AV06/4208X

Features, advantages and benefits of tube saw square:

1. **Square cut** – Exact tube preparation greatly reduces leakage caused by assembly failures.
2. **Contour clamping** – Tube is not distorted by clamping.
3. **No vice required** – For workshop application AV 6/42 can simply be clamped onto the tube without using a vice or other attachment.
4. **Replaceable guides** – Worn out guides can easily be replaced to maintain neat cutting result.
5. **Light** – At only 0.7 kg, the AV 6/42 should be carried in the toolbox of every hydraulic tube fitter.

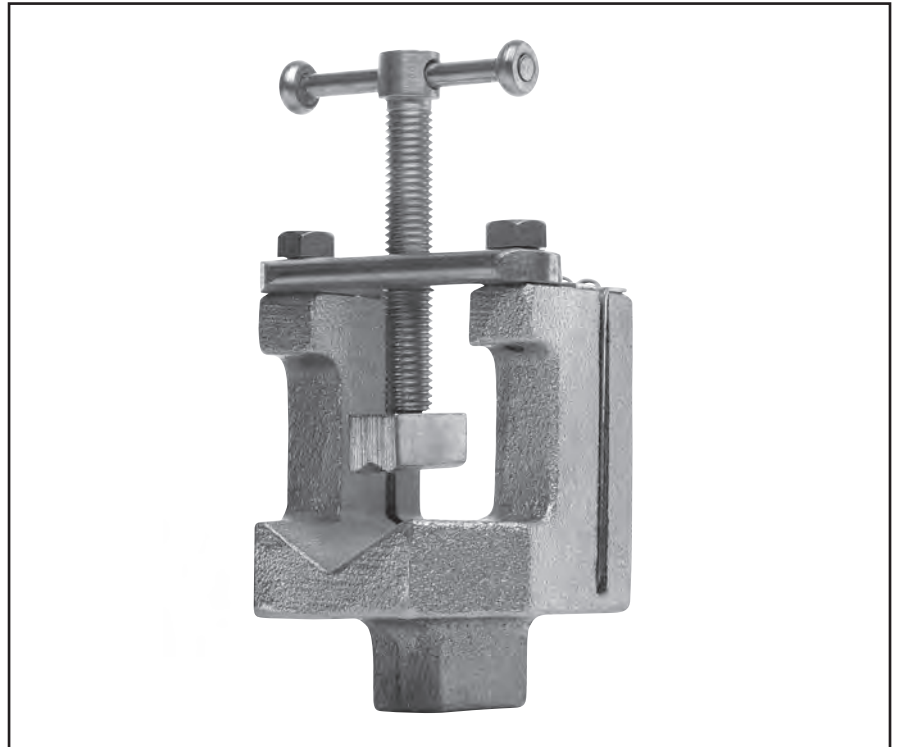

Cutting and bending tools

BAV 6/12 – Combined tube bending and cutting tool

The BAV 6/12 is a workshop device for neat tube cutting and simple but exact bending of small dimension EO-tube. Relatively small bending radii can be achieved.

The exact cut is achieved with hardened guides and using sawblades which are notched on both sides. The BAV 6/12 can be used in a vice or just be clamped onto a workbench.

Specifications:

Tube. OD: 6–12 mm
Weight: approx. 2 kg

Type	Order code
Combined tube bending and cutting tool including 3 bending rolls for 6 to 12 mm tube and bending lever	BAV06/12KPLX
Spare Parts	
Spare hardened guide	BAV06/1206X
Bending roll 6/8 mm	BAV06/1209X
Bending roll 10 mm	BAV06/1210X
Bending roll 12 mm	BAV06/1211X
Fixing roll	BAV06/1207X
Lever complete	BAV06/1220KPLX

Bending dimensions in mm			
Rolls for tube O.D.	6/8	10	12
Bending radius	19/20	25	26

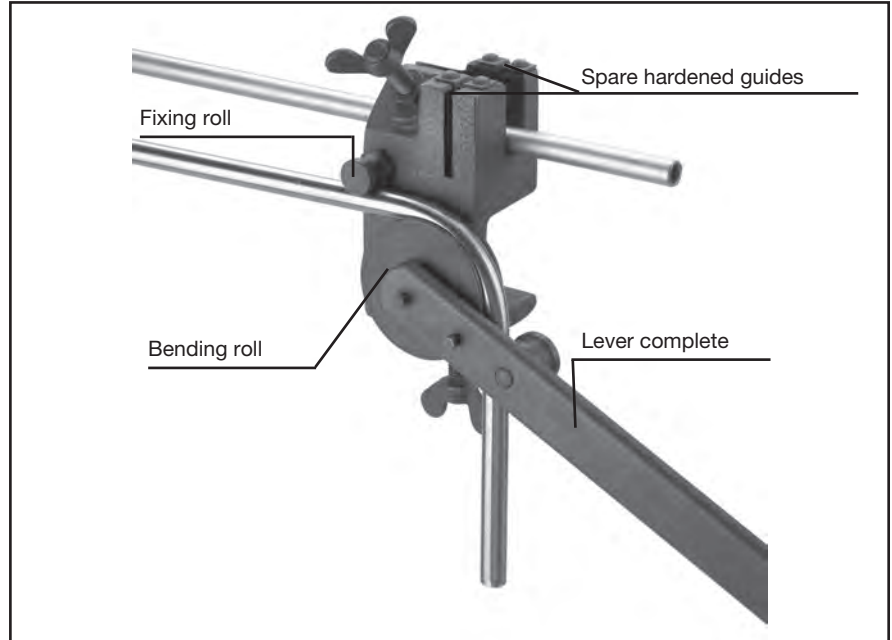

Features, advantages and benefits of combined tube bending and cutting tool:

- Bending and cutting** – The BAV 6/12 is a light multi-purpose tool for all small dimension tube assemblies.
- Square cut** – Exact tube preparation greatly reduces leakage caused by assembly failures.

- No vice required** – For workshop application BAV 6/12 can simply be clamped onto a workbench.
- Small bending radii** – Compact tube bends allow tight assemblies.
- Light** – At only 2 kg, the BAV 6/12 can be easily brought to the assembly site.
- Optimised bending roller contour** – Special shape of bending roller allows small bends without tube flattening.

In-Ex tube deburring tool 226

Material: Plastic, aluminum with hardened steel blades
Tube-O.D.: 4 to 42 mm

Type	Order code
Tube deburrer plastic, 4-38 mm, 3 blades	226B
Tube deburrer aluminium, 10-54 mm, many blades	226Z

Features, advantages and benefits of In-Ex tube deburring tool 226:

- Proper deburring** – Exact tube preparation greatly reduces leakage

caused by assembly failures.



Cutting and bending tools

BV 6/18 – Tube bending tool

The BV 6/18 is a flexible bending device for simple but exact bending of EO-tube up to 18 mm tube O.D. The high quality bending results are achieved by 6 interchangeable bending rollers.

The fixing roller can be individually adjusted to produce a precise bend transition.

Specifications:

Tube-O.D.: 6–18 mm
 Weight: approx. 4 kg

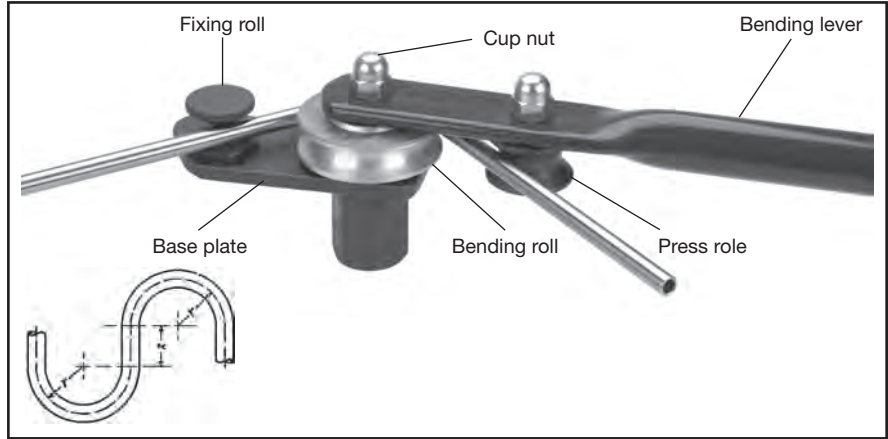

Type	Order code
Tube bending tool complete device including 6 bending rolls for 6 to 18 mm tube and bending lever	BV06/18KPLX
Spare Parts	
Bending roll 6/8 mm	BV06/1812X
Bending roll 10/12 mm	BV06/1803X
Bending roll 14 mm	BV06/1804X
Bending roll 15 mm	BV06/1805X
Bending roll 16 mm	BV06/1806X
Bending roll 18 mm	BV06/1807X
Fixing roll	BV06/1802X
Lever complete	BV06/1808KPLX

Bending dimensions in mm		
Rolls for tube O.D.	r	≈ X
6	33.0	35
8	34.0	35
10	35.5	35
12	36.5	35
14	36.5	35
15	44.0	38
16	44.0	38
18	51.5	42

Features, advantages and benefits of tube-bending tool:

- 1. Vice mounted** – For easy workshop use, the BV can be clamped into a vice.
- 2. Small bending radii** – Compact tube bends allow tight assemblies.
- 3. Light** – At only 4 kg, the BV 6/18 can be easily brought to each assembly site.
- 4. Optimised bending roller contour** – Special shape of bending roller allows small bends without tube flattening.

BV 20/25 – Tube bending tool

The BV 20/25 allows bending of medium size tube at the assembly site. The bending lever shows two universal studs. A bar extension can either be ordered or locally made.

Specifications:

Tube-O.D.: 20–25 mm
 3 bending segments: 20, 22, 25 mm
 Bending radius: $r = 86,5 \text{ mm}$
 $x = 52 \text{ mm}$
 Weight: approx. 15 kg (without bar extension)

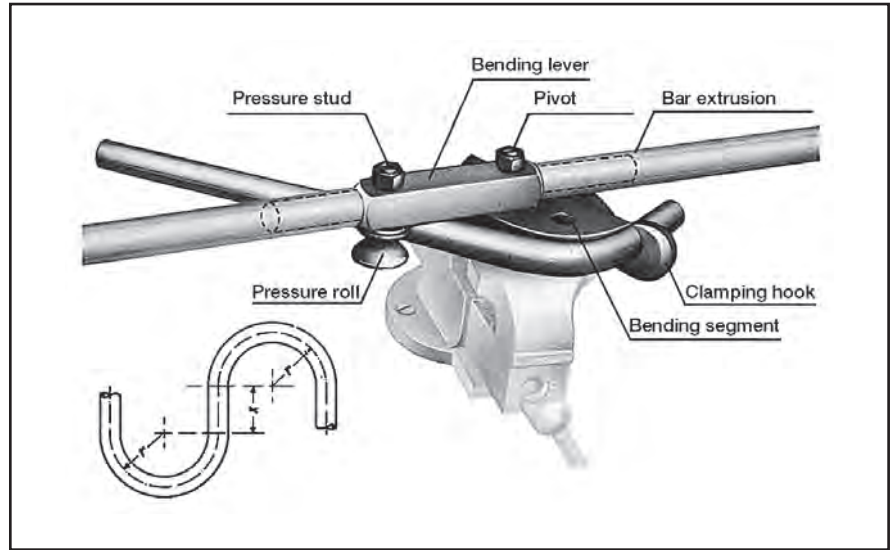

Type	Order code
BV 20/25 Tube bending tool bending device including 3 bending segments for tube O.D. 20 to 25 mm including bending lever without bar extension tube	BV20/25KPLX
Spare Parts	
Bending segment 20 mm	BV20/2501X
Bending segment 22 mm	BV20/2502X
Bending segment 25 mm	BV20/2503X
Fixing arm	BV20/2505X
Lever complete	BV20/2506KPLX
Bar extension tube	BV20/2510X

Features, advantages and benefits of tube-bending tool:

- Rigid design** – The solid design and the bar extension allow manual bending without heating the tube.
- Optimised bending roller contour** – Special shape of bending roller allows small bends without tube flattening.
- Shaped clamping** – Tube is not distorted by clamping.
- Small bending radii** – Compact tube bends allow for compact assemblies.
- Vice mounted** – For easy workshop use, the BV can be clamped into a vice.



Hand-tools

Par-Lok wrench

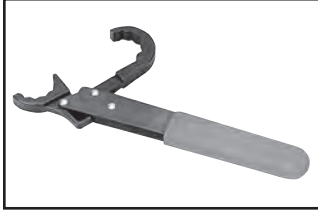

Par-Lok wrench

360° Snap-action ratchet wrench for inch sizes from 3/8" to 2 1/4" across flats. Inch sizes meet US government specifications and are listed as NSN-5120-00-474-7227.

Easy fitting assembly

Easy access ratchet wrench speeds fittings installation in tight locations. Rugged, snap-action jaws can be opened over tube lines, locked onto fitting hex and ratcheted within 1/8 turn. Full six point contact prevents fitting distortion common with wrench slippage. Ideal for tube line installations where compact runs required multiple fittings make-up, disassembly and remakes.

Specifications

Par-Lok wrenches are available individually. Par-Lok jaws are constructed from drop-forged, high carbon steel material with a black conversion coat finish. Par-Lok handles are made from heavy gauge steel material, heat treated and with a corrosion resistant black finish. Solid stainless steel rivets and tempered jaw springs are designed into every wrench for maximum strength.

Features, advantages and benefits of Par-Lok wrench:

1. **360°** – No slipping and hexagon damage.
2. **Snap-mechanism** – Ideal for tube fitting assembly.
3. **Light** – Par-Lok wrenches belong in the standard toolbox of each fitting engineer.

Inch Sizes			
Hex Size	Order code	Hex Size	Order code
3/8	860062-6	1 1/8	860062-18
7/16	860062-7	1 1/4	860062-20
1/2	860062-8	1 3/8	860062-22
9/16	860062-9	1 1/2	860062-24
5/8	860062-10	1 5/8	860062-26
1 1/16	860062-11	1 7/8	860062-30
3/4	860062-12	2	860062-32
1 3/16	860062-13	2 1/4	860062-36
7/8	860062-14		
1 5/16	860062-15		
1	860062-16		

WZK – Tool boxes

Tools which are regularly used for tube preparation and bending are available in organized tool boxes. Two sets are available:

Features, advantages and benefits:

1. **Well organised** – Nothing gets dirty, damaged, lost or forgotten.
2. **Practical** – In one box you take everything to the assembly site.
3. **Rigid** – The solid metal box is suitable for daily workshop use.



Type	Content	Order code
Toolbox WZK1	BV6/18 tube bending tool	WZK1KOMPLX
Toolbox WZK2	BV6/18 tube Bending tool, AV6/42 tube saw square, Hacksaw, Flat file, Deburring tool, fixture for assembly cones VOMO* and cone-template KONU*	WZK2KOMPLX

*VOMO/KONU are not part of the delivery.

O-ring assembly tools

CORG O-ring installation tool for O-Lok®

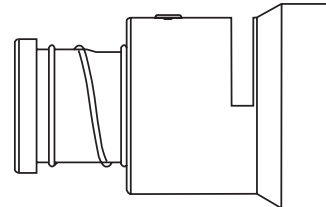

Parker's CORG Assembly Tools are designed to facilitate the installation of the O-ring into the half-dovetail groove of the O-ring face seal fitting. They are available in sizes –4 to –32 (6 mm to 50 mm/1/4" to 2" tube).

Ordering

CORG tool Order code	Fitting size	O-ring size
CORG-4	– 4	2-011
CORG-6	– 6	2-012
CORG-8	– 8	2-014
CORG-10	–10	2-016
CORG-12	–12	2-018
CORG-16	–16	2-021
CORG-20	–20	2-025
CORG-24	–24	2-029
CORG-32	–32	2-135

Operation

See chapter F “Fitting assembly” for detailed instructions

The CORG assembly tool is easy to use and can be operated in just a few steps:

1. Insert the O-ring into the slot located on the side of the tool.
2. Position the open end of the tool over the ORFS end of the fitting.
3. With the fitting end bottomed inside the tool, push the piston of the tool until the O-ring is released into the fitting groove.

O-ring pick for O-Lok®



O-ring pick

A plastic O-ring pick to allow easy removal of O-rings without causing damage to the fitting.

Ordering

Type	Order code
Plastic O-ring pick device	O-RINGPICK

Features, advantages and benefits of O-Ring installation tools

1. **Special** – O-ring installation tools are especially designed for O-Lok® fittings with CORG groove. O-rings are not torn or damaged at assembly.
2. **Cost saving** – O-ring installation tools are easy to use and save time and cost when O-rings need to be assembled.

Port cutting tools

Counterbore tools and thread taps for metric ports

For manufacturing metric ports to ISO 6149 (Details see chapter D).

These tools allow correct manufacturing of metric port connections. Counterbore tools are made of high speed tool steel (HSS).

Ordering counterbore tools

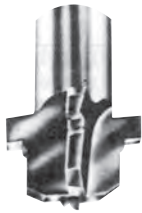

ISO 6149 Port size	Order code
	Large Spot face ¹⁾
M 08×1.0	R1449A
M 10×1.0	R1450A
M 12×1.5	R1451A
M 14×1.5	R1452A
M 16×1.5	R1453A
M 18×1.5	R1454A
M 22×1.5	R1455A
M 27×2.0	R1456A
M 33×2.0	R1457A
M 42×2.0	R1458A
M 48×2.0	R1459A

1) with ID-groove



Counterbore tools and thread taps for straight SAE thread ports

For manufacturing UNF ports to SAE J 1926-1 (details see chapter D)

These tools allow correct manufacturing of UNF port connections. Counterbore tools and thread taps are made of high speed tool steel (HSS).

counterbore tools

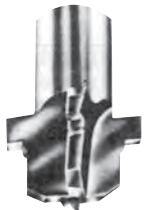

Use with UNF thread size	SAE dash size	Order code
5/16-24	2	Y-34730
3/8-24	3	Y-34731
7/16-20	4	Y-34732
1/2-20	5	Y-34733
9/16-18	6	Y-34734
3/4-16	8	Y-34735
7/8-14	10	Y-34736
1 1/16-12	12	Y-34737
1 3/16-12	14	Y-34738
1 5/16-12	16	Y-34739
1 5/8-12	29	Y-34740
1 7/8-12	24	Y-34741
2 1/2-12	32	Y-34743

thread taps



Use with UNF thread size	SAE dash size	Order code
5/16-24	2	5/16X24 UNF-2B
3/8-24	3	3/8X24 UNF-2B
7/16-20	4	7/16X20 UNF-2B
1/2-20	5	1/2X20 UNF-2B
9/16-18	6	9/16X18 UNF-2B
3/4-16	8	3/4X16 UNF-2B
7/8-14	10	7/8X14 UNF-2B
1 1/16-12	12	1 1/16X12 UNF-2B
1 3/16-12	14	1 3/16X12 UNF-2B
1 5/16-12	16	1 5/16X12 UNF-2B
1 5/8-12	29	1 5/8X12 UNF-2B
1 7/8-12	24	1 7/8X12 UNF-2B
2 1/2-12	32	2 1/2X12 UNF-2B

Operation of port cutting tools

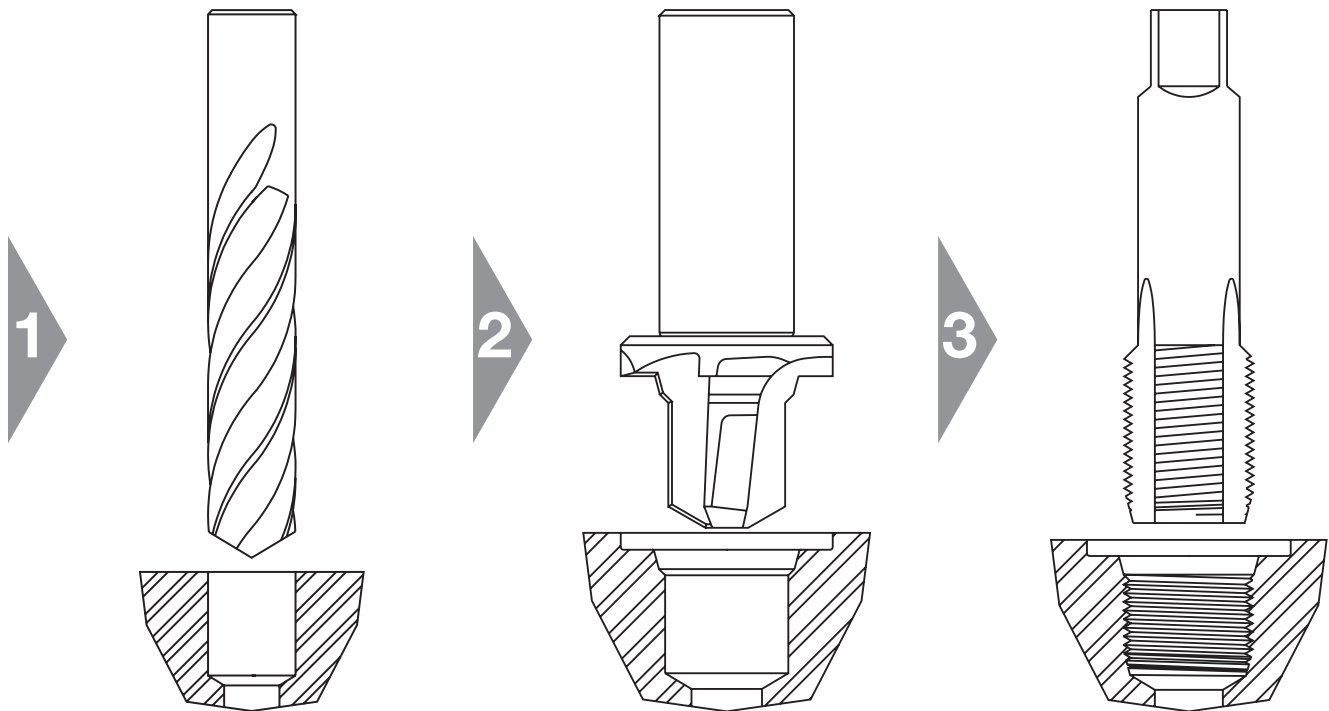

1. Pilot hole drilling

2. Port counterboring

3. Thread tapping

Note:

All dimensions must be according to relevant standards. See chapter D for details.

It is necessary to create a spotface surface which is flat and perpendicular to the port. Smooth finish to prevent leakage or O-ring extrusion.

Parker counterbore tools are made from high speed tool steel (HSS). Regular HSS port tapping tools are intended for workshop use and repair.

Maximum lifetime of Parker counterbores can be achieved by:

- use for cutting mild steel or aluminium only
- staying within recommended cutting speed for HSS / port material
- sufficient lubrication and cooling
- workshop use and repair only

For serial production of hydraulic ports, these Parker workshop tools are not suitable.

For production, Parker generally recommends to use hard carbide alloy.

Thread identification

Thread identification kit

The thread identification tools are beneficial in the assistance of the identification of international threads such as:

- European threads (Metric, BSPP, BSPT threads) and
- U.S. threads (NPT and SAE straight threads UNF)

The Thread Identification Kit is equipped with a set of calipers, thread profiles, and an instruction booklet.

The components of the thread ID Kit are no high precision gauges but simple instruments for workshop use.

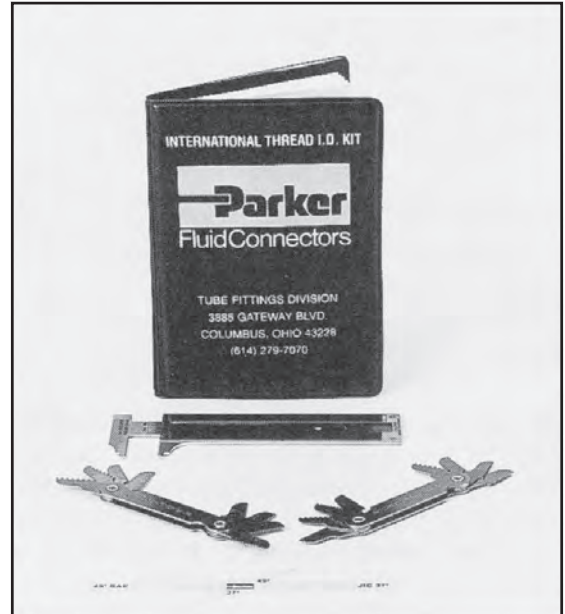

Ordering

Type	Order code
Thread identification kit	MIK-1

Attention: The kit is only available in english!

Portboard

Portboards are suitable for thread identification of male stud connectors. The two portboards are machined with female threads for quick and easy identification by simply screwing the appropriate male port end.

- European (Metric, BSPP/BSPT threads)
- U.S. (NPT and SAE straight threads UNF)

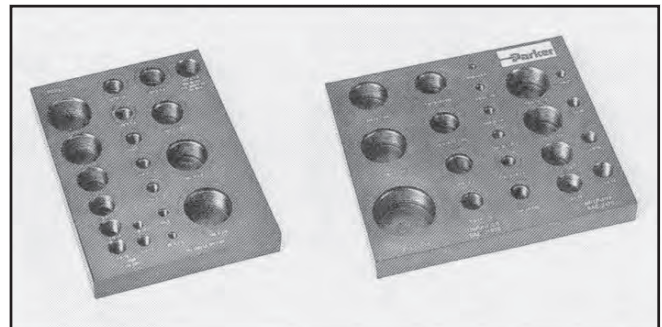

Ordering

Type	Order code
Portboard for NPT and SAE straight threads	PORTBOARD A
Portboard for Metric and BSPP/BSPT threads	PORTBOARD B

Assembly tooling

Sample case for product presentation

This sample case assists in product presentation. A sample of all HPCE tube fitting systems is included as part of the contents. Individual samples of necessary components such as nuts and rings are provided. All components are clearly arranged in stable, high-quality cases.

Features, advantages and benefits

- 1. **Valuable sales assistance** - with this sample case you can clearly demonstrate the function and the special features, advantages, and benefits of the Parker HPCE-fitting components.
- 2. **Practical** - the sample case is incredibly light and can easily be taken on any customer visit. Distributors use the case as a sales aid in stores.
- 3. **Efficient** - the case can be used quick and with little effort
- 4. **Durable** - the components in the case are made entirely of stainless steel, are robust, and shine just as much after years of use as they did when they were new.
- 5. **Dry Technology** - the sample case is a practical and powerful sales aid. The components of all fitting types- whether a cutting ring system or *Dry Technology* - are arranged clearly.



Ordering





Type	Order code
HPCE sample case	TFDE-SAMPLECASE

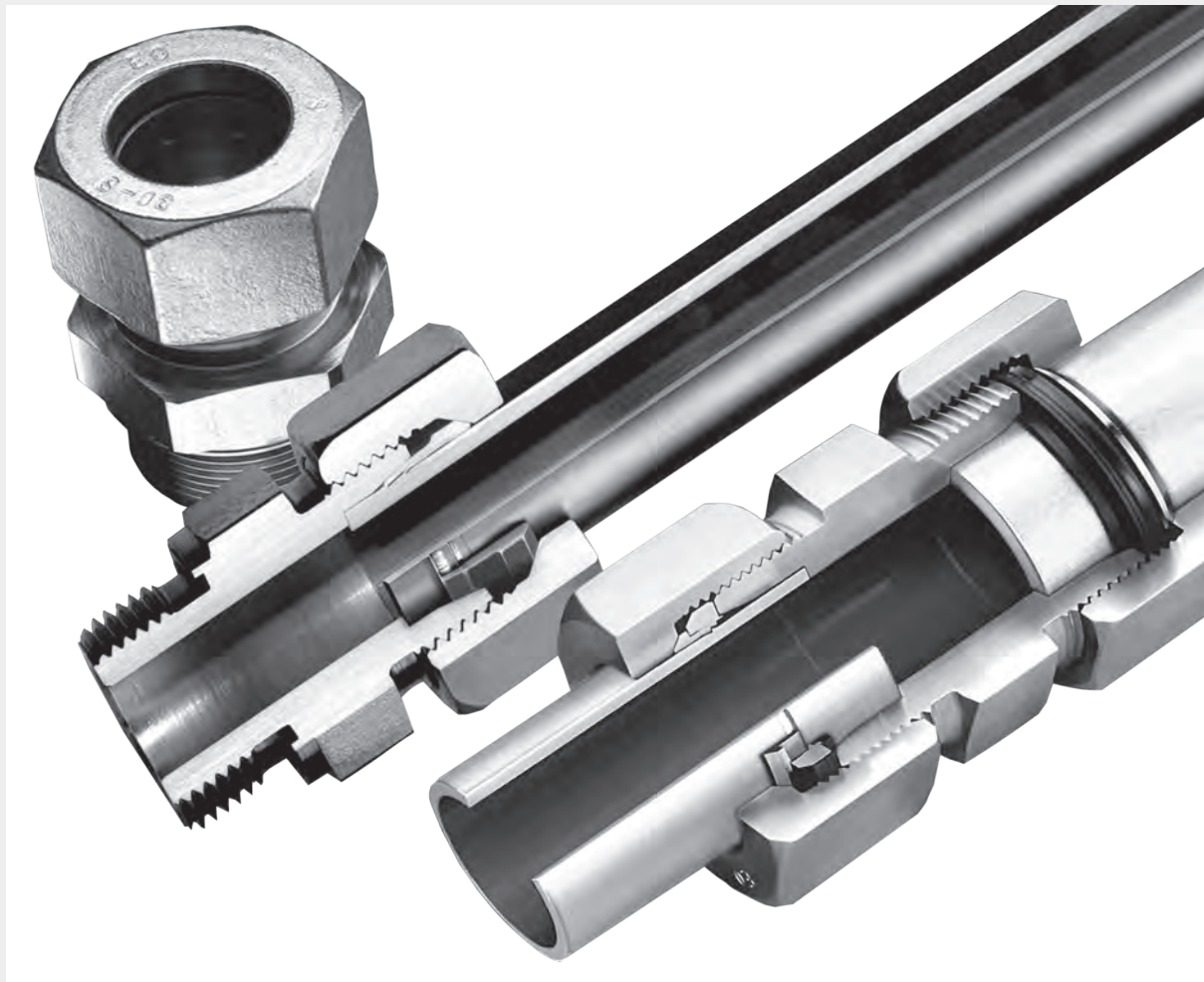

EO[®] Ermeto Original
DIN fittings

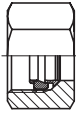
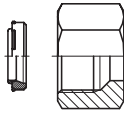

Visual index

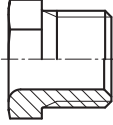
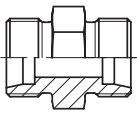
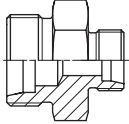
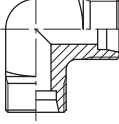
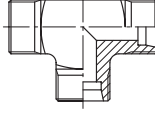
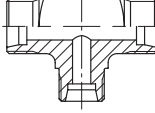
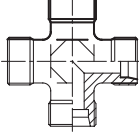
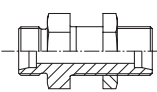
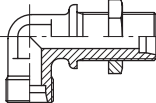
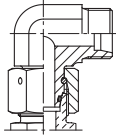
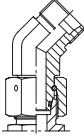
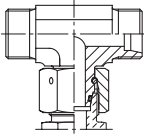
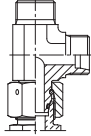
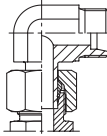
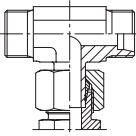
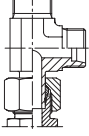
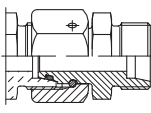
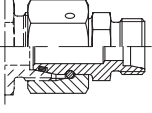
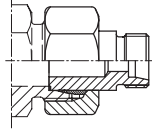
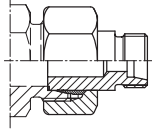
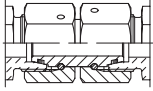
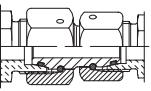
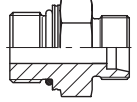
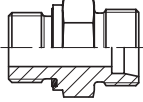
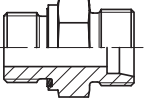
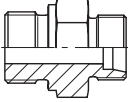
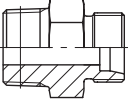
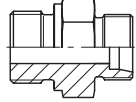
Fitting components	 <p>FM p. 110</p>	 <p>FORM p. 112</p>	 <p>M p. 114</p>	 <p>D p. 115</p>	 <p>PSR p. 115</p>	 <p>DPR p. 116</p>
	 <p>S p. 117</p>					
Tube to tube	 <p>G p. 118</p>	 <p>GR p. 119</p>	 <p>W p. 120</p>	 <p>T p. 121</p>	 <p>TR p. 122</p>	 <p>K p. 124</p>
	 <p>SV p. 125</p>		 <p>WSV p. 126</p>			
Tube to swivel	 <p>EW p. 127</p>	 <p>EV p. 128</p>	 <p>ET p. 129</p>	 <p>EL p. 130</p>	 <p>EVW p. 131</p>	 <p>EVT p. 132</p>
	 <p>EVL p. 133</p>	 <p>DA p. 134</p>	 <p>RED p. 135</p>	 <p>KOR (Steel/Brass) p. 139</p>	 <p>KOR (Stainless steel) p. 142</p>	
Swivel to swivel	 <p>GZ p. 144</p>		 <p>GZR p. 145</p>			
Male stud connector	 <p>GEO p. 147</p>	 <p>GE-M-ED p. 148</p>	 <p>GE-R-ED p. 149</p>	 <p>GE-R p. 151</p>	 <p>GE-R(KEG) p. 153</p>	 <p>GE-M p. 154</p>

Visual index

Male stud connector

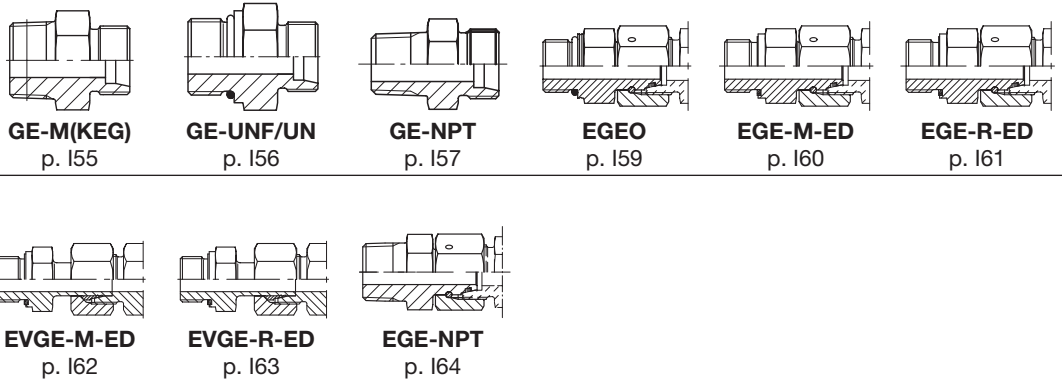

Swivel adjustable

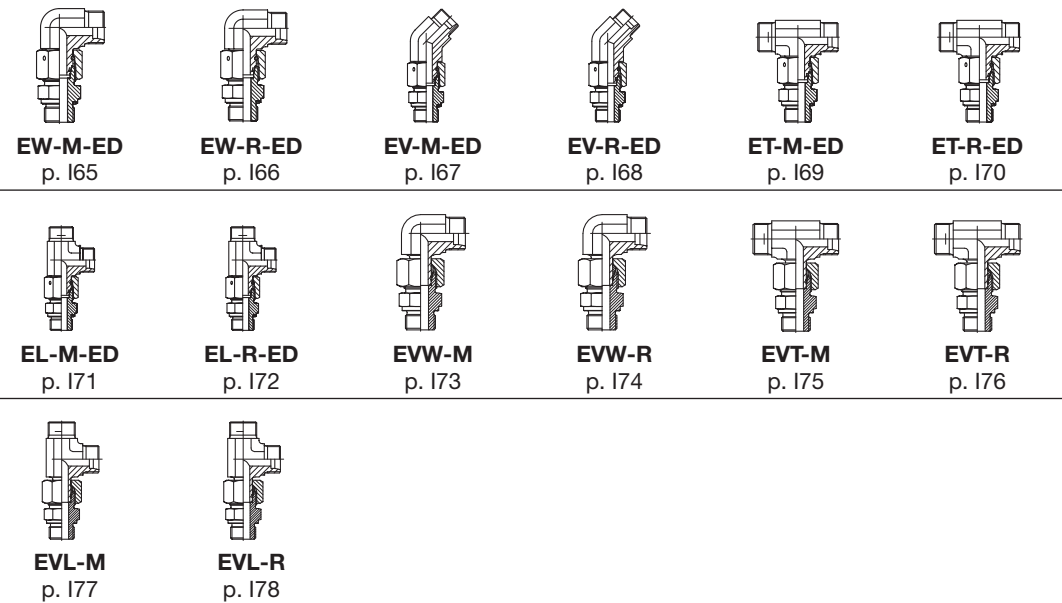



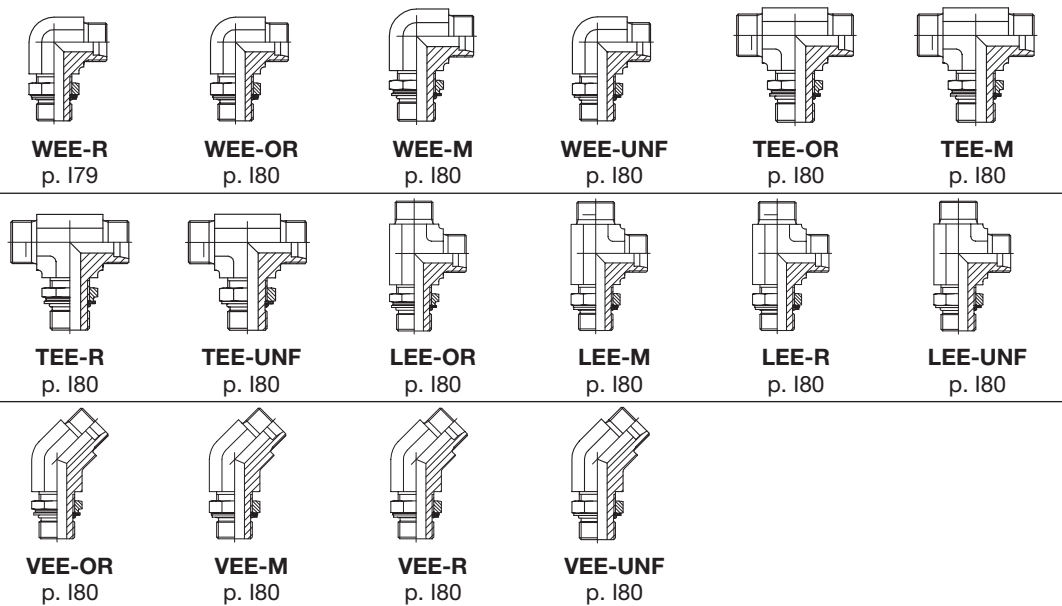





Locknut adjustable

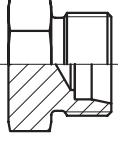
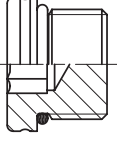
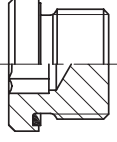
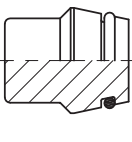
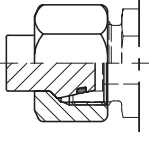
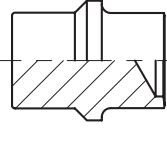
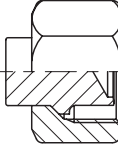

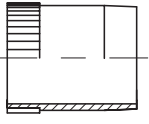
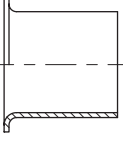
Visual index

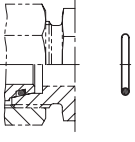
Banjo fittings	<p>WH-M-KDS p. 181</p>	<p>WH-M p. 182</p>	<p>WH-R-KDS p. 183</p>	<p>WH-R p. 184</p>	<p>TH-M-KDS p. 185</p>	<p>TH-M p. 186</p>
	<p>TH-R-KDS p. 187</p>	<p>TH-R p. 188</p>	<p>SWVE-M/KDS p. 189</p>	<p>SWVE-R/KDS p. 190</p>		
Non adjustable	<p>WE-NPT p. 191</p>	<p>WE-M(KEG) p. 192</p>	<p>WE-M p. 193</p>	<p>WE-R p. 194</p>	<p>WE-R (KEG) p. 195</p>	<p>TE-M p. 196</p>
	<p>TE-R p. 197</p>	<p>TE-R (KEG) p. 198</p>	<p>TE-M(KEG) p. 199</p>	<p>LE-M p. 1100</p>	<p>LE-R p. 1101</p>	<p>LE-R (KEG) p. 1102</p>
	<p>LE-M(KEG) p. 1103</p>					
Tube to female	<p>GAI-M p. 1104</p>	<p>GAI-R p. 1105</p>	<p>GAI-NPT p. 1106</p>			
Port reducers	<p>RI-ED p. 1107</p>	<p>RI p. 1108</p>				
Pressure gauge adapter	<p>MAV p. 1109</p>	<p>MAVE p. 1110</p>				

Visual index

Plugs	 <p>ROV p. I111</p>	 <p>VSTI M-OR p. I112</p>	 <p>VSTI M/R-ED p. I113</p>	 <p>VKA p. I114</p>	 <p>VKAM p. I115</p>	 <p>BUZ p. I116</p>
	 <p>BUZM p. I117</p>					
Components	 <p>GM p. I118</p>	 <p>VH p. I119</p>	 <p>E p. I120</p>	 <p>DOZ p. I121</p>	 <p>ED p. I122</p>	 <p>OR p. I123</p>
	 <p>DKI p. I125</p>	 <p>KDS p. I126</p>	 <p>KD p. I127</p>	 <p>DKA p. I128</p>		

How to order



DIN fittings

GE-R-ED Male stud connector

Male BSPB thread – ED-seal (ISO 1179) / EO 24° cone end

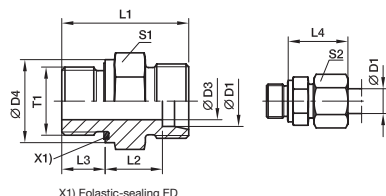

The right way to order made easy!

Step 1 Selecting order code

- 1.1 All fitting sizes available in our fitting program are clearly listed in the index at the front of this catalogue.
- 1.2 Open the catalogue at the corresponding page containing detailed information of the product of your choice.
- 1.3 Select the required fitting size! The basic order code is printed in bold type on the right-hand side of the table of dimensions.

Example: **GE16SREDOMD**

Step 2 Selecting material, surface and sealing-material

Now simply add the corresponding code for the surface and material variant of the product you require to the basic order code. This code is contained in the table printed at the bottom of every page.

2.1 Alternative sealing material

Example: Cr(VI)-free steel fitting with ED-seal in FKM material.
GE16SRED+OMD+VIT+CF
= GE16SREDVITOMDCF

Example: Stainless steel fitting with ED-seal in NBR material (e. g. Perbunan).
GE16SREDOMD+NBR+71
= GE16SREDNBROMD71

Step 3 When ordering fittings complete with nuts and rings

- 3.1. Metal sealed cutting rings PSR/DPR/D: For these types please delete the 'OMD' or 'X' suffixes.
 Example: **GE16SREDCF**
- 3.2. Soft sealed EO-2 functional nut: For these types please delete the 'OMD' or 'X' suffixes and add a 'Z' before the series suffix (LL, L, S)
 Example: **order with EO-2 functional nut**
GE16(+Z)SREDCF
= GE16ZSREDCF

Perbunan = registered trademark of Bayer

Series	D1	T1	D3	D4	L1	L2	L3	L4	S1	S2	Weight g/1 piece	Order code*	PN (bar ¹⁾)		
													CF	71	MS
LL ²⁾	04	G 1/8 A	3	14	20.0	9.5	6.5	19	14	10	10	GE04LLREDOMD	100	100	63
	06	G 1/8 A	4	14	20.0	8.0	6.5	20	14	12	11	GE06LLREDOMD	100	100	63
L ³⁾	06	G 1/8 A	4	14	23.5	8.5	8.0	23	14	14	13	GE06LREDOMD	500	315	200
	06	G 1/4 A	4	19	29.0	10.0	12.0	25	19	14	28	GE06LR1/4EDOMD	500	315	200
	06	G 3/8 A	4	22	30.5	11.5	12.0	26	22	14	44	GE06LR3/8EDOMD	420	315	200
	06	G 1/2 A	4	27	33.0	12.0	14.0	27	27	14	61	GE06LR1/2EDOMD	400	315	200
	08	G 1/4 A	6	19	29.0	10.0	12.0	25	19	17	27	GE08LREDOMD	500	315	200
	08	G 1/8 A	4	14	24.5	9.5	8.0	24	14	17	16	GE08LR1/8EDOMD	500	315	200
	08	G 3/8 A	6	22	30.5	11.5	12.0	26	22	17	45	GE08LR3/8EDOMD	420	315	200
	08	G 1/2 A	6	27	33.0	12.0	14.0	27	27	17	74	GE08LR1/2EDOMD	400	315	200
	10	G 1/4 A	6	19	30.0	11.0	12.0	26	19	19	29	GE10LREDOMD	500	315	200
	10	G 1/8 A	4	14	25.5	10.5	8.0	25	17	19	21	GE10LR1/8EDOMD	500	315	200
	10	G 3/8 A	8	22	31.5	12.5	12.0	27	22	19	43	GE10LR3/8EDOMD	420	315	200
	10	G 1/2 A	8	27	34.0	13.0	14.0	28	27	19	71	GE10LR1/2EDOMD	400	315	200
	12	G 3/8 A	9	22	31.5	12.5	12.0	27	22	22	41	GE12LR3/8EDOMD	420	315	200
	12	G 1/8 A	4	14	26.5	11.5	8.0	26	19	22	26	GE12LREDOMD	420	315	200
	12	G 1/4 A	6	19	31.0	12.0	12.0	27	19	22	39	GE12LR1/4EDOMD	420	315	200
	12	G 1/2 A	10	27	34.0	13.0	14.0	28	27	22	71	GE12LR1/2EDOMD	400	315	200
	12	G 3/4 A	10	32	37.0	14.0	16.0	29	32	22	101	GE12LR3/4EDOMD	420	315	200
	15	G 1/2 A	11	27	35.0	14.0	14.0	29	27	27	66	GE15LREDOMD	315	200	100
	15	G 3/8 A	9	22	32.5	13.5	12.0	29	24	27	59	GE15LR3/8EDOMD	315	200	100
	15	G 3/4 A	12	32	38.0	15.0	16.0	30	32	27	111	GE15LR3/4EDOMD	400	315	200
	18	G 1/2 A	14	27	36.0	14.5	14.0	31	27	32	74	GE18LREDOMD	250	160	100
	18	G 3/8 A	9	22	33.5	14.0	12.0	30	27	32	66	GE18LREDOMD	250	160	100
	18	G 3/4 A	15	32	38.0	14.5	16.0	31	32	32	110	GE18LREDOMD	250	160	100
	22	G 3/4 A	18	32	40.0	16.5	16.0	33	32	36	102	GE22LR1/2EDOMD	250	160	100
	22	G 1/2 A	14	27	38.0	16.5	14.0	33	32	36	91	GE22LR1/2EDOMD	250	160	100
	22	G 1 A	19	40	43.0	17.5	18.0	34	41	36	189	GE22LR1EDOMD	250	160	100
	28	G 1 A	23	40	43.0	17.5	18.0	34	41	41	170	GE28LREDOMD	250	160	100
	28	G 3/4 A	18	32	41.0	17.5	16.0	34	41	41	159	GE28LR3/4EDOMD	250	160	100
	28	G 1 1/4 A	24	50	46.0	18.5	20.0	35	50	41	316	GE28LR11/4EDOMD	250	160	100
	35	G 1 1/4 A	30	50	48.0	17.5	20.0	39	50	50	272	GE35LREDOMD	250	160	100
	35	G 1 A	23	40	46.0	17.5	18.0	39	46	50	226	GE35LR1EDOMD	250	160	100
	35	G 1 1/2 A	30	55	52.0	19.5	22.0	41	55	50	423	GE35LR11/2EDOMD	250	160	100
	42	G 1 1/2 A	36	55	52.0	19.0	22.0	42	55	60	343	GE42LREDOMD	250	160	100
	42	G 1 A	23	40	48.0	19.0	18.0	42	55	60	324	GE42LR1EDOMD	250	160	100
	42	G 1 1/4 A	30	50	50.0	19.0	20.0	42	55	60	348	GE42LR11/4EDOMD	250	160	100

¹⁾ Pressure shown = item deliverable
²⁾ LL = very light series; ³⁾ L = light series

PN (bar¹) = PN (MPa)
 10

Delivery without nut and ring. Information on ordering complete fittings or alternative sealing materials see page 17.

*Please add the suffixes below according to the material/surface required.

Material		Standard sealing material (no additional suffix needed)
Steel, zinc plated, Cr(VI)-free	GE18LREDOMDCF	
Steel, zinc plated, Cr(VI)-free	GE18LREDOMD71	NBR
Stainless Steel	GE18LREDOMDMS	VIT
Brass		NBR



I51

Catalogue 4100-10/UK

The corresponding order variant is contained in the table printed at the bottom of every DIN chapter.



How to order EO-Fittings:

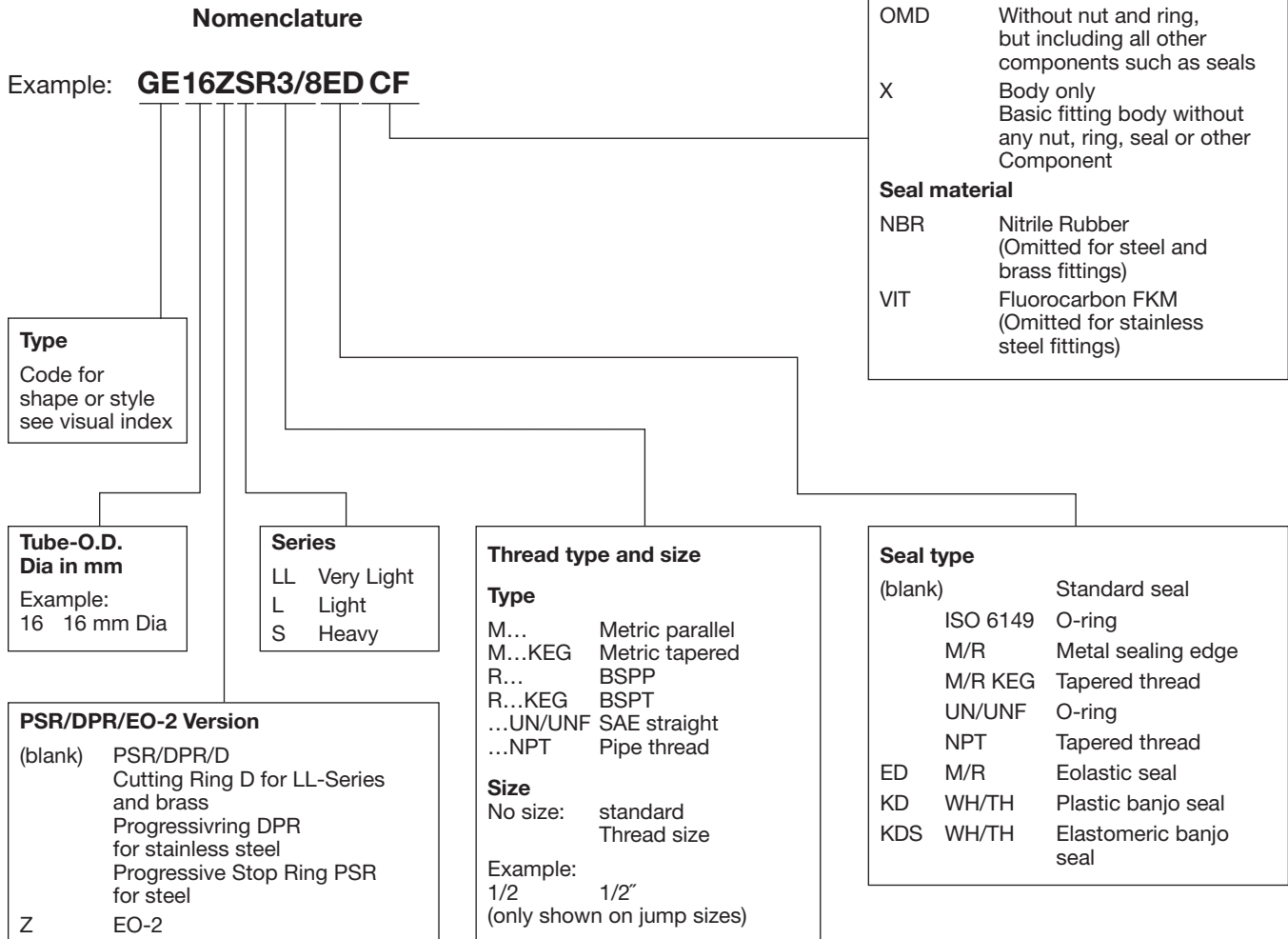

Examples

Order code	Description	Order code	Description
GE12ZSR1/2EDCF	Straight male stud, EO-2, 20 mm tube O.D., heavy series, G 1/2 BSPP, Eolastic seal, complete with nut and ring, Cr(VI)-free steel fitting, all seals NBR	EVT08LOMDMS	Adjustable standpipe branch tee, 8 mm tube O.D., light series, brass fitting without nut and ring, standpipe preassembled with nut and ring.
GE12LR71X	Straight male stud, 12 mm tube O.D., light series, G 3/8 BSPP, metal seal type B, stainless steel fitting, body only	EL38VITOMDCF	Adjustable swivel nut run tee 38 mm tube O.D., heavy series, zinc-plated steel fitting without nut and ring. Swivel nut end with FKM seal
		DOZ04LL	Spare seal for EO-2 joints, 4 mm O.D., very light series, steel with nitrile rubber seal

Perbunan = registered trademark of Bayer

Codes for fittings/styles shapes

BUZ	Blanking plug for cones
D	Cutting ring – EO 24° cone end
DA	Distance piece adapter – EO 24° DKO swivel/EO 24° cone end
DKA	Sealing ring for banjo fittings WH/TH and SWVE
DKI	Sealing ring for pressure gauge connectors
DOZ	EO-2 Soft sealing ring
DPR	Progressive ring – EO 24° cone end
E	Tube/hose insert for plastic tubing
ED	Eolastic soft seal (for BSPP and metric parallel threads)
EGE-M-ED	Swivel connector – Male metric thread – ED-seal (ISO 9974)/EO 24° DKO swivel
EGE-NPT	Swivel connector – Male NPT thread (SAE J476)/EO 24° DKO swivel
EGEO	Swivel connector – Male metric thread – O-ring (ISO 6149)/EO 24° DKO swivel
EGE-R-ED	Swivel connector – Male BSPP thread – ED-seal (ISO 1179)/EO 24° DKO swivel
EL	Swivel nut run tee – EO 24° cone end/EO 24° DKO swivel
EL-M-ED	Assembled adjustable swivel run tee – EO 24° cone end/Male metric thread – ED-seal (ISO 9974)
EL-R-ED	Assembled adjustable swivel run tee – EO 24° cone end/Male BSPP thread – ED-seal (ISO 1179)
ET	Swivel nut branch tee – EO 24° cone end/EO 24° DKO swivel
ET-M-ED	Assembled adjustable swivel branch tee – EO 24° cone end/Male metric thread – ED-seal (ISO 9974)
ET-R-ED	Assembled adjustable swivel branch tee – EO 24° cone end/Male BSPP thread – ED-seal (ISO 1179)
EV	Swivel nut 45° elbow – EO 24° cone end/EO 24° DKO swivel
EVGE-M-ED	Standpipe connector – Male metric thread – ED (ISO 9974)/EO standpipe adjustable
EVGE-R-ED	Standpipe connector – Male BSPP thread – ED-seal (ISO 1179)/EO standpipe adjustable
EVL	Standpipe run tee – EO 24° cone end/EO stand pipe adjustable
EVL-M	Assembled adjustable standpipe run tee – EO 24° cone end/Male metric thread – metal sealing edge (ISO 9974)
EVL-R	Assembled adjustable standpipe run tee – EO 24° cone end/Male BSPP thread – metal sealing edge (ISO 1179)
EV-M-ED	Assembled adjustable swivel 45° elbow – EO 24° cone end/Male metric thread – ED-seal (ISO 9974)
EV-R-ED	Assembled adjustable swivel 45° elbow – EO 24° cone end/Male BSPP thread – ED-seal (ISO 1179)
EVT	Standpipe branch tee – EO 24° cone end/EO stand pipe adjustable
EVT-M	Assembled adjustable standpipe branch tee – EO 24° cone end/Male metric thread – metal sealing edge (ISO 9974)
EVT-R	Assembled adjustable standpipe branch tee – EO 24° cone end/Male BSPP thread – metal sealing edge (ISO 1179)
EVW	Standpipe elbow – EO 24° cone end/EO stand pipe adjustable
EVW-M	Assembled adjustable standpipe elbow – EO 24° cone end/Male metric thread – metal sealing edge (ISO 9974)
EVW-R	Assembled adjustable standpipe elbow – EO 24° cone end/Male BSPP thread – metal sealing edge (ISO 1179)
EW	Swivel nut elbow – EO 24° cone end/EO 24° DKO swivel
EW-M-ED	Assembled adjustable swivel elbow – EO 24° cone end/Male metric thread – ED-seal (ISO 9974)
EW-R-ED	Assembled adjustable swivel elbow – EO 24° cone end/Male BSPP thread – ED-seal (ISO 1179)
FM	EO2 Functional nut
FORM	EO2-FORM Set
G	Union – EO 24° cone end
GAI-M	Female connector – Female metric thread (ISO 9974-1)/EO 24° cone end
GAI-NPT	Female connector – Female NPT thread (SAE 476)/EO 24° cone end
GAI-R	Female connector – Female BSPP thread (ISO 1179-1)/EO 24° cone end
GE-M	Male stud connector – Male metric thread – metal sealing edge (ISO 9974)/EO 24° cone end
GE-M (KEG)	Male stud connector – Male short metric taper thread (DIN 3852-1, type C)/EO 24° cone end
GE-M-ED	Male stud connector – Male metric thread – ED (ISO 9974)/EO 24° cone end
GE-NPT	Male stud connector – Male NPT thread (SAE J476)/EO 24° cone end
GEO	Male stud connector – Male metric thread – O-ring (ISO 6149)/EO 24° cone end
GE-R	Male stud connector – Male BSPP thread – metal sealing edge (ISO 1179)/EO 24° cone end
GE-R (KEG)	Male stud connector – Male short BSP taper thread (DIN 3852-2, type C)/EO 24° cone end
GE-R-ED	Male stud connector – Male BSPP thread – ED-seal (ISO 1179)/EO 24° cone end
GE-UNF/UN	Male stud connector – Male UNF/UN thread – O-ring (ISO 11926)/EO 24° cone end
GM	Locknut for bulkheads SV and WSV
GR	Straight reducer – EO 24° cone end
GZ	Swivel union – EO 24° DKO swivel
GZR	Swivel reducer – EO 24° DKO swivel
K	Union cross – EO 24° cone end

Codes for fittings/styles shapes

KD	Soft sealing ring for banjo fittings WH/TH from stainless steel
KDS	Soft sealing ring for banjo fittings SWVE, WH and TH from steel
KOR	Tube end reducer – Steel and Brass – EO stand pipe adjustable/EO 24° cone end
LEE	Adjustable locknut run tee – EO 24° cone end/Adjustable thread
LE-M	Male stud run tee – EO 24° cone end/Male metric thread – metal sealing edge (ISO 9974)
LE-M (KEG)	Male stud run tee – EO 24° cone end/Male short metric taper thread (DIN 3852-1, Form C)
LE-R	Male stud run tee – EO 24° cone end/Male BSPP thread – metal sealing edge (ISO 1179)
LE-R (KEG)	Male stud run tee – EO 24° cone end/Male short BSP taper thread (DIN 3852-2, type C)
M	Nut- EO 24° Cone end
MAV	Pressure gauge connector – Female BSPP thread/EO 24° cone end
MAVE	Pressure gauge swivel connector – Female BSPP thread/EO 24° DKO swivel
OR	O-ring
PSR	Progressive stop ring – EO 24° cone end
RED	Tube end reducer – EO 24° DKO swivel/EO 24° cone end
RI	Thread reducer/expander – Male BSPP thread – metal sealing edge (ISO 1179)/Female BSPP thread (ISO 1179-1)
RI-ED	Thread reducer/expander – Male BSPP thread – ED-seal (ISO 1179)/Female BSPP thread (ISO 1179-1)
ROV	Blanking plug for tube ends – EO 24° cone end
S	Sleeve screw – for threaded ports according to DIN 3854
SV	Bulkhead union – EO 24° cone end
SWVE-M	Metric male stud banjo elbow – EO 24° cone end/Metric male stud with metal seal ring
SWVE-M-KDS	Metric male stud banjo elbow – EO 24° cone end/Metric male stud with soft seal ring
SWVE-R	BSPP male stud banjo elbow – EO 24° cone end/BSPP male stud with metal seal ring
SWVE-R-KDS	BSPP male stud banjo elbow – EO 24° cone end/BSPP male stud with soft seal ring
T	Union T – EO 24° cone end
TEE	Adjustable locknut branch tee – EO 24° cone end/Adjustable thread
TE-M	Male stud branch tee – EO 24° cone end/Male metric thread – metal sealing edge (ISO 9974)
TE-M (KEG)	Male stud branch tee – EO 24° cone end/Male short metric taper thread (DIN 3852-1, type C)
TE-R	Male stud branch tee – EO 24° cone end/Male BSPP thread – metal sealing edge (ISO 1179)
TE-R (KEG)	Male stud branch tee – EO 24° cone end/Male short BSP taper thread (DIN 3852-2, type C)
TH-M	High pressure banjo tee – EO 24° cone end/Male metric thread with metal sealing ring
TH-M-KDS	High pressure banjo tee – EO 24° cone end/Male metric thread with soft seal ring
TH-R	High pressure banjo tee – EO 24° cone end/Male BSPP thread with metal sealing ring
TH-R-KDS	High pressure banjo tee – EO 24° cone end/Male BSPP thread with soft seal ring
TR	Tee Reducer – EO 24° cone end
VEE	Adjustable locknut 45° elbow – EO 24° cone end/Adjustable thread
VH	Support sleeve for thin-walled metal tubing
VKA	Blanking plug for cones – EO 24° DKO swivel
VKAM	Blanking plug with nut for cone – EO 24° DKO swivel
VSTI M/R-ED	Blanking plug for ports – Male metric thread – ED-seal (ISO 9974) – Male BSPP thread – ED-seal (ISO 1179)
VSTI M-OR	Blanking plug for ports – Male metric thread – O-ring (ISO 6149)
W	Union elbow – EO 24° cone end
WEE	Adjustable locknut elbow – EO 24° cone end/Adjustable thread
WE-M	Male stud elbow – EO 24° cone end/Male metric thread – metal sealing edge (ISO 9974)
WE-M (KEG)	Male stud elbow – EO 24° cone end/Male short metric taper thread (DIN 3852-1, type C)
WE-NPT	Male stud elbow – EO 24° cone end/Male NPT thread (SAE J476)
WE-R	Male stud elbow – EO 24° cone end/Male BSPP thread – metal sealing edge (ISO 1179)
WE-R (KEG)	Male stud elbow – EO 24° cone end/Male short BSP taper thread (DIN 3852-2, type C)
WH-M	High pressure banjo elbow – EO 24° cone end/Male metric thread with metal sealing ring
WH-M-KDS	High pressure banjo elbow – EO 24° cone end/Male metric thread with soft seal ring
WH-R	High pressure banjo elbow – EO 24° cone end/Male BSPP thread with metal sealing ring
WH-R-KDS	High pressure banjo elbow – EO 24° cone end/Male BSPP thread with soft seal ring
WSV	Bulkhead elbow – EO 24° cone end

FM EO2-Functional nut

for steel tubes

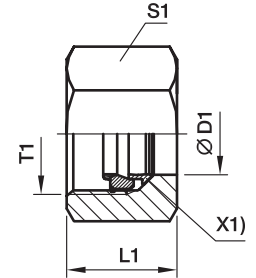

X1) Retaining ring

Series	D1 	T1	L1	S1	Order code				Weight g/1 piece
					FM...CF Steel, zinc plated Cr(VI) free passiv. +Sealing Sealing NBR	PN (bar)	FM...VITCF Steel, zinc plated Cr(VI) free passiv. +Sealing Sealing FKM	PN (bar)	
LL	04	M 08×1.0	11.0	10	FM04LLCF	100	—	100	5
	06	M 10×1.0	11.5	12	—	—	—	—	6
L	06	M 12×1.5	14.5	14	FM06LCF	500	FM06LVITCF	500	12
	08	M 14×1.5	14.5	17	FM08LCF	500	FM08LVITCF	500	17
	10	M 16×1.5	15.5	19	FM10LCF	500	FM10LVITCF	500	22
	12	M 18×1.5	15.5	22	FM12LCF	400	FM12LVITCF	400	30
	15	M 22×1.5	17.0	27	FM15LCF	400	FM15LVITCF	400	48
	18	M 26×1.5	18.0	32	FM18LCF	400	FM18LVITCF	400	70
	22	M 30×2.0	20.0	36	FM22LCF	250	FM22LVITCF	250	94
	28	M 36×2.0	21.0	41	FM28LCF	250	FM28LVITCF	250	106
	35	M 45×2.0	24.0	50	FM35LCF	250	FM35LVITCF	250	160
	42	M 52×2.0	24.0	60	FM42LCF	250	FM42LVITCF	250	244
S	06	M 14×1.5	16.5	17	FM06SCF	800	FM06SVITCF	800	20
	08	M 16×1.5	16.5	19	FM08SCF	800	FM08SVITCF	800	23
	10	M 18×1.5	17.5	22	FM10SCF	800	FM10SVITCF	800	37
	12	M 20×1.5	17.5	24	FM12SCF	630	FM12SVITCF	630	39
	16	M 24×1.5	20.5	30	FM16SCF	630	FM16SVITCF	630	72
	20	M 30×2.0	24.0	36	FM20SCF	420	FM20SVITCF	420	121
	25	M 36×2.0	27.0	46	FM25SCF	420	FM25SVITCF	420	221
	30	M 42×2.0	29.0	50	FM30SCF	420	FM30SVITCF	420	248
38	M 52×2.0	32.5	60	FM38SCF	420	FM38SVITCF	420	367	

$$\frac{\text{PN (bar)}}{10} = \text{PN (MPa)}$$

FM EO2-Functional nut

for stainless steel tubes

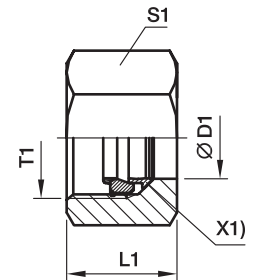

X1) Retaining ring

Series	D1 	T1	L1	S1	Order code								Weight g/1 piece	
					FM...71 Stainless Steel		FM...NBR71 Stainless Steel		FM...SSA Steel, zinc plated Cr(VI) free passiv. +Sealing, Retaining ring: Stainless Steel		FM...VITSSA Steel, zinc plated Cr(VI) free passiv. +Sealing, Retaining ring: Stainless Steel			
					Sealing FKM	PN (bar)	Sealing NBR	PN (bar)	Sealing NBR	PN (bar)	Sealing FKM	PN (bar)		
LL	04	M 08×1.0	11.0	10	—	—	—	—	FM04LLSSA	100	—	—	5	
	06	M 10×1.0	11.5	12	—	—	—	—	FM06LLSSA	100	—	—	6	
L	06	M 12×1.5	14.5	14	FM06L71	315	FM06LNBR71	315	FM06LSSA	315	FM06LVITSSA	315	12	
	08	M 14×1.5	14.5	17	FM08L71	315	FM08LNBR71	315	FM08LSSA	315	FM08LVITSSA	315	17	
	10	M 16×1.5	15.5	19	FM10L71	315	FM10LNBR71	315	FM10LSSA	315	FM10LVITSSA	315	22	
	12	M 18×1.5	15.5	22	FM12L71	315	FM12LNBR71	315	FM12LSSA	315	FM12LVITSSA	315	30	
	15	M 22×1.5	17.0	27	FM15L71	315	FM15LNBR71	315	FM15LSSA	315	FM15LVITSSA	315	48	
	18	M 26×1.5	18.0	32	FM18L71	315	FM18LNBR71	315	FM18LSSA	315	FM18LVITSSA	315	70	
	22	M 30×2.0	20.0	36	FM22L71	160	FM22LNBR71	160	FM22LSSA	160	FM22LVITSSA	160	94	
	28	M 36×2.0	21.0	41	FM28L71	160	FM28LNBR71	160	FM28LSSA	160	FM28LVITSSA	160	106	
	35	M 45×2.0	24.0	50	FM35L71	160	FM35LNBR71	160	FM35LSSA	160	FM35LVITSSA	160	160	
	42	M 52×2.0	24.0	60	FM42L71	160	FM42LNBR71	160	FM42LSSA	160	FM42LVITSSA	160	244	
	S	06	M 14×1.5	16.5	17	FM06S71	630	FM06SNBR71	630	FM06SSSA	630	FM06SVITSSA	630	20
		08	M 16×1.5	16.5	19	FM08S71	630	FM08SNBR71	630	FM08SSSA	630	FM08SVITSSA	630	23
10		M 18×1.5	17.5	22	FM10S71	630	FM10SNBR71	630	FM10SSSA	630	FM10SVITSSA	630	37	
12		M 20×1.5	17.5	24	FM12S71	630	FM12SNBR71	630	FM12SSSA	630	FM12SVITSSA	630	39	
16		M 24×1.5	20.5	30	FM16S71	400	FM16SNBR71	400	FM16SSSA	400	FM16SVITSSA	400	72	
20		M 30×2.0	24.0	36	FM20S71	400	FM20SNBR71	400	FM20SSSA	400	FM20SVITSSA	400	121	
25		M 36×2.0	27.0	46	FM25S71	400	FM25SNBR71	400	FM25SSSA	400	FM25SVITSSA	400	221	
30		M 42×2.0	29.0	50	FM30S71	400	FM30SNBR71	400	FM30SSSA	400	FM30SVITSSA	400	248	
38	M 52×2.0	32.5	60	FM38S71	315	FM38SNBR71	315	FM38SSSA	315	FM38SVITSSA	315	367		

$\frac{\text{PN (bar)}}{10} = \text{PN (MPa)}$

EO2-FORM Set

for steel tubes

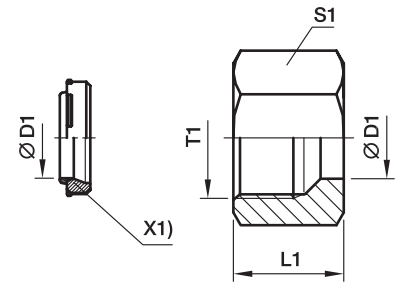

X1) Sealing (DOZ)

Series	D1 	T1	L1	S1	Order code		PN (bar)	Weight g/1 piece
					FORM...CF Steel, zinc plated Cr(VI) free +Seal NBR	FORM...VITCF Steel, zinc plated Cr(VI) free +Seal FKM		
L	06	M 12×1.5	14.5	14	FORM06LCF	FORM06LVITCF	500	11
	08	M 14×1.5	14.5	17	FORM08LCF	FORM08LVITCF	500	16
	10	M 16×1.5	15.5	19	FORM10LCF	FORM10LVITCF	500	20
	12	M 18×1.5	15.5	22	FORM12LCF	FORM12LVITCF	400	27
	15	M 22×1.5	17.0	27	FORM15LCF	FORM15LVITCF	400	45
	18	M 26×1.5	18.0	32	FORM18LCF	FORM18LVITCF	400	67
	22	M 30×2.0	20.0	36	FORM22LCF	FORM22LVITCF	250	88
	28	M 36×2.0	21.0	41	FORM28LCF	FORM28LVITCF	250	99
	35	M 45×2.0	24.0	50	FORM35LCF	FORM35LVITCF	250	162
	42	M 52×2.0	24.0	60	FORM42LCF	FORM42LVITCF	250	233
S	06	M 14×1.5	16.5	17	FORM06SCF	FORM06SVITCF	800	19
	08	M 16×1.5	16.5	19	FORM08SCF	FORM08SVITCF	800	22
	10	M 18×1.5	17.5	22	FORM10SCF	FORM10SVITCF	800	34
	12	M 20×1.5	17.5	24	FORM12SCF	FORM12SVITCF	630	38
	16	M 24×1.5	20.5	30	FORM16SCF	FORM16SVITCF	630	71
	20	M 30×2.0	24.0	36	FORM20SCF	FORM20SVITCF	420	115
	25	M 36×2.0	27.0	46	FORM25SCF	FORM25SVITCF	420	216
	30	M 42×2.0	29.0	50	FORM30SCF	FORM30SVITCF	420	242
38	M 52×2.0	32.5	60	FORM38SCF	FORM38SVITCF	420	366	

EO2-FORM Set

for stainless steel tubes

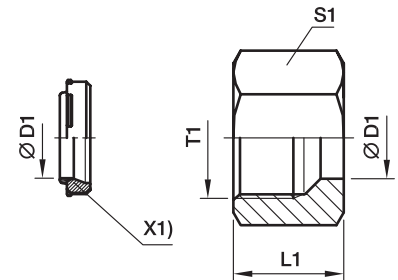

X1) Sealing (DOZ)

Series	D1 	T1	L1	S1	Order code				PN (bar)	Weight g/1 piece
					FORM...71 Stainless Steel Sealing FKM	FORM...NBR71 Stainless Steel Sealing NBR	FORM...CF Steel, zinc plated Cr(VI) free +Seal NBR	FORM...VITCF Steel, zinc Cr(VI) free +Seal FKM		
L	06	M 12×1.5	14.5	14	FORM06L71	FORM06LNBR71	FORM06LCF	FORM06LVITCF	315	11
	08	M 14×1.5	14.5	17	FORM08L71	FORM08LNBR71	FORM08LCF	FORM08LVITCF	315	16
	10	M 16×1.5	15.5	19	FORM10L71	FORM10LNBR71	FORM10LCF	FORM10LVITCF	315	21
	12	M 18×1.5	15.5	22	FORM12L71	FORM12LNBR71	FORM12LCF	FORM12LVITCF	315	27
	15	M 22×1.5	17.0	27	FORM15L71	FORM15LNBR71	FORM15LCF	FORM15LVITCF	315	46
	18	M 26×1.5	18.0	32	FORM18L71	FORM18LNBR71	FORM18LCF	FORM18LVITCF	315	68
	22	M 30×2.0	20.0	36	FORM22L71	FORM22LNBR71	FORM22LCF	FORM22LVITCF	160	89
	28	M 36×2.0	21.0	41	FORM28L71	FORM28LNBR71	FORM28LCF	FORM28LVITCF	160	101
	35	M 45×2.0	24.0	50	FORM35L71	FORM35LNBR71	FORM35LCF	FORM35LVITCF	160	165
	42	M 52×2.0	24.0	60	FORM42L71	FORM42LNBR71	FORM42LCF	FORM42LVITCF	160	237
S	06	M 14×1.5	16.5	17	FORM06S71	FORM06SNBR71	FORM06SCF	FORM06SVITCF	630	19
	08	M 16×1.5	16.5	19	FORM08S71	FORM08SNBR71	FORM08SCF	FORM08SVITCF	630	22
	10	M 18×1.5	17.5	22	FORM10S71	FORM10SNBR71	FORM10SCF	FORM10SVITCF	630	35
	12	M 20×1.5	17.5	24	FORM12S71	FORM12SNBR71	FORM12SCF	FORM12SVITCF	630	39
	16	M 24×1.5	20.5	30	FORM16S71	FORM16SNBR71	FORM16SCF	FORM16SVITCF	400	71
	20	M 30×2.0	24.0	36	FORM20S71	FORM20SNBR71	FORM20SCF	FORM20SVITCF	400	117
	25	M 36×2.0	27.0	46	FORM25S71	FORM25SNBR71	FORM25SCF	FORM25SVITCF	400	219
	30	M 42×2.0	29.0	50	FORM30S71	FORM30SNBR71	FORM30SCF	FORM30SVITCF	400	246
38	M 52×2.0	32.5	60	FORM38S71	FORM38SNBR71	FORM38SCF	FORM38SVITCF	315	372	

M Nut · EO 24° Cone end

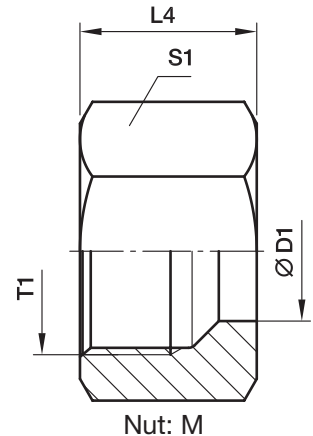

Series	D1 	T1	L4	S1	Weight g/1 piece	Order code*	PN (bar) ¹⁾		
							CF	71	MS
LL ²⁾	04	M 08×1.0	11.0	10	4	M04LL	100	100	63
	06	M 10×1.0	11.5	12	6	M06LL	100	100	63
	08	M 12×1.0	12.0	14	7	M08LL	100	100	63
	10	M 14×1.0	12.5	17	11	M10LL	100	100	63
	12	M 16×1.0	13.0	19	13	M12LL	100	100	63
L ³⁾	06	M 12×1.5	14.5	14	10	M06L	500	315	200
	08	M 14×1.5	14.5	17	15	M08L	500	315	200
	10	M 16×1.5	15.5	19	18	M10L	500	315	200
	12	M 18×1.5	15.5	22	25	M12L	400	315	200
	15	M 22×1.5	17.0	27	42	M15L	400	315	200
	18	M 26×1.5	18.0	32	62	M18L	400	315	200
	22	M 30×2.0	20.0	36	82	M22L	250	160	100
	28	M 36×2.0	21.0	41	89	M28L	250	160	100
	35	M 45×2.0	24.0	50	137	M35L	250	160	100
	42	M 52×2.0	24.0	60	216	M42L	250	160	100
S ⁴⁾	06	M 14×1.5	16.5	17	17	M06S	800	630	400
	08	M 16×1.5	16.5	19	20	M08S	800	630	400
	10	M 18×1.5	17.5	22	31	M10S	800	630	400
	12	M 20×1.5	17.5	24	34	M12S	630	630	400
	16	M 24×1.5	20.5	30	66	M16S	630	400	250
	20	M 30×2.0	24.0	36	102	M20S	420	400	250
	25	M 36×2.0	27.0	46	202	M25S	420	400	250
	30	M 42×2.0	29.0	50	219	M30S	420	400	250
38	M 52×2.0	32.5	60	339	M38S	420	315	200	

¹⁾ Pressure shown = item deliverable

²⁾ LL = very light series; ³⁾ L = light series; ⁴⁾ S = heavy series

$$\frac{\text{PN (bar)}}{10} = \text{PN (MPa)}$$

*Please add the **suffixes** below according to the material/surface required.

Order code suffixes		
Material	Suffix surface and material	Example
Steel, zinc plated, Cr(VI)-free	CFX	M16SCFX
Stainless Steel	EODURX	M16SEODURX
Brass	MSX	M16SMSX

D Cutting ring · PSR Progressive stop ring

for EO 24° cone end

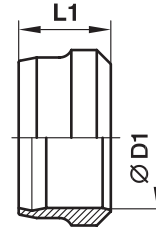

Cutting ring:
D

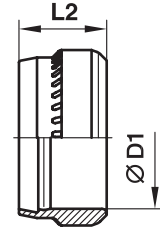

Progressive stop ring:
PSR

Series	D1	Cutting ring D Order code						Progressive stop ring PSR Order code				Weight g/1 pc.
		L1	Steel, zinc plated Cr(VI) free	PN (bar)	Stainless Steel	PN (bar)	Brass	PN (bar)	L2	Steel, zinc plated Cr(VI) free	PN (bar)	
LL	04	6.0	D04LLX	100	D04LL71X	100	D04LLMSX	63	—	—	—	0.3
	06	7.0	D06LLX	100	D06LL71X	100	D06LLMSX	63	—	—	—	0.8
	08	7.0	D08LLX	100	D08LL71X	100	D08LLMSX	63	—	—	—	1.0
	10	7.0	D10LLX	100	D10LL71X	100	D10LLMSX	63	—	—	—	1.3
	12	7.5	D12LLX	100	D12LL71X	100	D12LLMSX	63	—	—	—	1.6
	L	06	9.5	—	—	—	—	D06LMSX	200	9.5	PSR06LX	500
08		9.0	—	—	—	—	D08LMSX	200	9.5	PSR08LX	500	2.2
10		10.0	—	—	—	—	D10LMSX	200	10.0	PSR10LX	500	3.1
12		10.0	—	—	—	—	D12LMSX	200	10.0	PSR12LX	400	3.5
15		10.0	—	—	—	—	D15LMSX	200	10.0	PSR15LX	400	4.5
18		10.0	—	—	—	—	D18LMSX	200	10.0	PSR18LX	400	5.5
22		10.5	—	—	—	—	D22LMSX	100	10.5	PSR22LX	250	7.3
28		10.5	—	—	—	—	D28LMSX	100	10.5	PSR28LX	250	9.4
35		13.0	—	—	—	—	D35LMSX	100	13.0	PSR35LX	250	20.0
42		13.5	—	—	—	—	D42LMSX	100	13.0	PSR42LX	250	23.0
S	06	9.5	—	—	—	—	D06SMSX	400	9.5	PSR06SX	800	1.7
	08	9.0	—	—	—	—	D08SMSX	400	9.5	PSR08SX	800	3.2
	10	10.0	—	—	—	—	D10SMSX	400	10.0	PSR10SX	800	3.1
	12	10.0	—	—	—	—	D12SMSX	400	10.0	PSR12SX	630	3.5
	16	10.5	—	—	—	—	D16SMSX	250	10.0	PSR16SX	630	5.6
	20	12.5	—	—	—	—	D20SMSX	250	13.0	PSR20SX	420	11.4
	25	12.5	—	—	—	—	D25SMSX	250	13.0	PSR25SX	420	13.3
	30	13.0	—	—	—	—	D30SMSX	250	13.0	PSR30SX	420	19.3
38	13.5	—	—	—	—	D38SMSX	200	13.0	PSR38SX	420	22.5	

$\frac{\text{PN (bar)}}{10} = \text{PN (MPa)}$

DPR Progressive ring

for EO 24° cone end

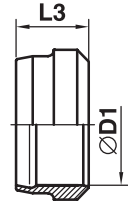

Progressive ring: DPR

Series	D1 	L3	Progressive ring DPR Order code		PN (bar)	Weight g/1 piece
			Stainless Steel	Stainless Steel SPH		
			L	06 08 10 12 15 18 22 28 35 42		
S	06 08 10 12 16 20 25 30 38	9.0 9.0 9.5 9.8 9.5 12.5 12.5 12.5 13.0	DPR06L71X DPR08L71X DPR10L71X DPR12L71X DPR16S71X DPR20S71X DPR25S71X DPR30S71X DPR38S71X	DPR06LSPH71X DPR08LSPH71X DPR10LSPH71X DPR12LSPH71X DPR16SSPH71X DPR20SSPH71X DPR25SSPH71X DPR30SSPH71X DPR38SSPH71X	630 630 630 630 400 400 400 400 315	1.7 3.2 3.1 3.5 5.6 11.4 13.3 19.3 22.5

$$\frac{PN \text{ (bar)}}{10} = PN \text{ (MPa)}$$

S Sleeve screw

for threaded ports according to DIN 3854

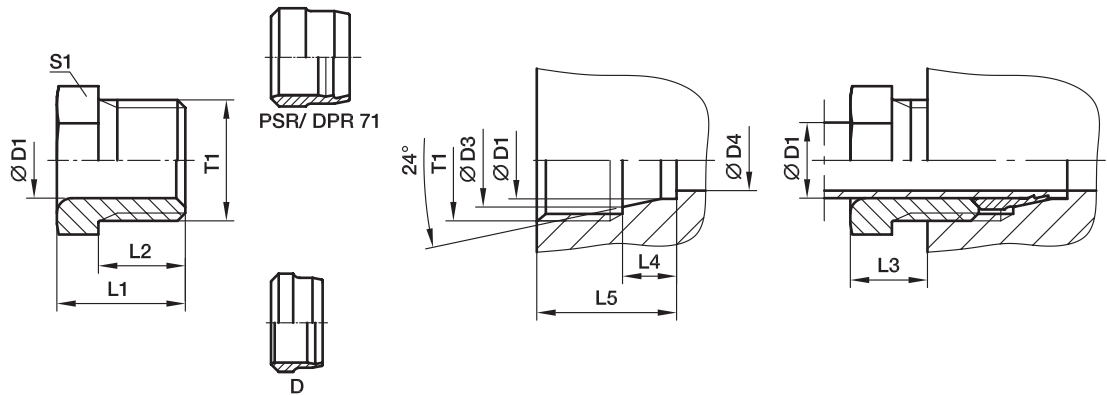

Series	D1 	T1	D3	D4	L1	L2	L3	L4	L5	S1	Weight g/1 piece	Order code*	PN (bar) ¹⁾	
													CF	71
LL ²⁾	04	M 08×1.0	5.0	3.0	12	8.0	6	4.0	12.5	8	3	S04LL	100	100
	06	M 10×1.0	7.5	4.5	13	9.0	7	5.5	14.5	10	4	S06LL	100	100
	08	M 12×1.0	9.5	6.0	14	9.5	7	5.5	14.5	12	6	S08LL	100	100
L ³⁾	06	M 12×1.5	8.1	4.0	16	11.5	10	7.0	18.5	12	9	S06L	315	315
	08	M 14×1.5	10.1	6.0	16	11.5	10	7.0	18.5	14	11	S08L	315	315
	10	M 16×1.5	12.3	8.0	17	11.5	10	7.0	18.5	17	15	S10L	315	315
	12	M 18×1.5	14.3	10.0	18	12.0	10	7.0	19.0	19	19	S12L	315	315

¹⁾ Pressure shown = item deliverable

²⁾ LL = very light series; ³⁾ L = light series

$\frac{\text{PN (bar)}}{10} = \text{PN (MPa)}$

*Please add the **suffixes** below according to the material/surface required.

Order code suffixes		
Material	Suffix surface and material	Example
Steel, zinc plated, Cr(VI)-free	CFX	S10LCFX
Stainless Steel	71X	S10L71X

G Union

EO 24° cone end

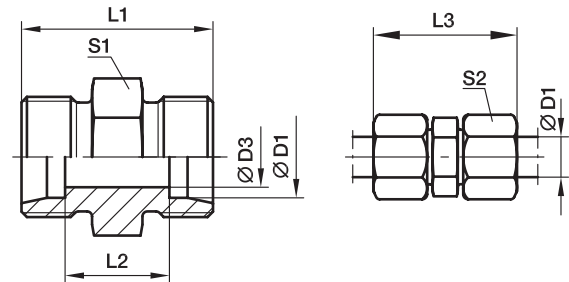

Series	D1 	D3	L1	L2	L3	S1	S2	Weight g/1 piece	Order code*	PN (bar) ¹⁾		
										CF	71	MS
LL ²⁾	04	3.0	20	12	31	9	10	5	G04LL	100	100	63
	06	4.5	20	9	32	11	12	7	G06LL	100	100	63
	08	6.0	23	12	35	12	14	10	G08LL	100	100	63
	10	8.0	23	12	35	14	17	13	G10LL	100	100	63
	12	10.0	23	11	35	17	19	16	G12LL	100	100	63
L ³⁾	06	4.0	24	10	39	12	14	12	G06L	500	315	200
	08	6.0	25	11	40	14	17	16	G08L	500	315	200
	10	8.0	27	13	42	17	19	23	G10L	500	315	200
	12	10.0	28	14	43	19	22	28	G12L	400	315	200
	15	12.0	30	16	46	24	27	51	G15L	400	315	200
	18	15.0	31	16	48	27	32	69	G18L	400	315	200
	22	19.0	35	20	52	32	36	90	G22L	250	160	100
	28	24.0	36	21	54	41	41	137	G28L	250	160	100
	35	30.0	41	20	63	46	50	214	G35L	250	160	100
	42	36.0	43	21	66	55	60	296	G42L	250	160	100
S ⁴⁾	06	4.0	30	16	45	14	17	26	G06S	800	630	400
	08	5.0	32	18	47	17	19	37	G08S	800	630	400
	10	7.0	32	17	49	19	22	44	G10S	800	630	400
	12	8.0	34	19	51	22	24	60	G12S	630	630	400
	16	12.0	38	21	57	27	30	90	G16S	630	400	250
	20	16.0	44	23	66	32	36	143	G20S	420	400	250
	25	20.0	50	26	74	41	46	251	G25S	420	400	250
	30	25.0	54	27	80	46	50	330	G30S	420	400	250
	38	32.0	61	29	90	55	60	545	G38S	420	315	200

1) Pressure shown = item deliverable

2) LL = very light series; 3) L = light series; 4) S = heavy series

$$\frac{\text{PN (bar)}}{10} = \text{PN (MPa)}$$

Delivery without nut and ring. Information on ordering complete fittings see page I7.

*Please add the **suffixes** below according to the material/surface required.

Order code suffixes		
Material	Suffix surface and material	Example
Steel, zinc plated, Cr(VI)-free	CFX	G16SCFX
Stainless Steel	71X	G16S71X
Brass	MSX	G16SMSX

GR Straight reducer

EO 24° cone end

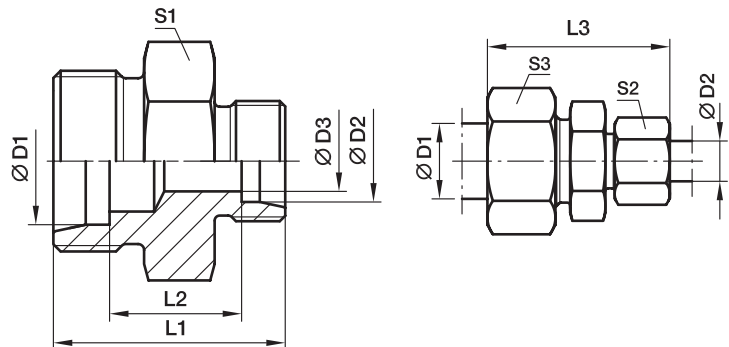

Series	D1	D2	D3	L1	L2	L3	S1	S2	S3	Weight g/1 piece	Order code*	PN (bar) ¹⁾		
												CF	71	MS
LL ²⁾	06	04	3.0	20	10.5	32	11	10	12	7	GR06/04LL	100	100	63
	08	04	3.0	22	12.5	34	12	10	14	9	GR08/04LL	100	100	63
	08	06	4.5	22	11.0	34	12	12	14	11	GR08/06LL	100	100	63
L ³⁾	08	06	4.0	25	11.0	40	14	14	17	16	GR08/06L	500	315	200
	10	06	4.0	26	12.0	41	17	14	19	21	GR10/06L	500	315	200
	10	08	6.0	26	12.0	41	17	17	19	21	GR10/08L	500	315	200
	12	06	4.0	27	13.0	42	19	14	22	26	GR12/06L	400	315	200
	12	08	6.0	27	13.0	42	19	17	22	26	GR12/08L	400	315	200
	12	10	8.0	28	14.0	43	19	19	22	29	GR12/10L	400	315	200
	15	10	8.0	29	15.0	45	24	19	27	46	GR15/10L	400	315	200
	15	12	10.0	29	15.0	45	24	22	27	45	GR15/12L	400	315	200
	18	10	8.0	30	15.5	46	27	19	32	65	GR18/10L	400	315	200
	18	12	10.0	30	15.5	46	27	22	32	64	GR18/12L	400	315	200
	18	15	12.0	31	16.5	48	27	27	32	65	GR18/15L	400	315	200
	22	12	10.0	32	17.5	48	32	22	36	80	GR22/12L	250	160	100
	22	15	12.0	33	18.5	50	32	27	36	89	GR22/15L	250	160	100
	22	18	15.0	33	18.0	50	32	32	36	89	GR22/18L	250	160	100
	28	18	15.0	34	19.0	52	41	32	41	142	GR28/18L	250	160	100
	28	22	19.0	36	21.0	54	41	36	41	139	GR28/22L	250	160	100
	35	22	19.0	39	21.0	59	46	36	50	202	GR35/22L	250	160	100
	35	28	24.0	39	21.0	59	46	41	50	206	GR35/28L	250	160	100
	42	35	30.0	43	21.5	66	55	50	60	330	GR42/35L	250	160	100
	S ⁴⁾	08	06	4.0	32	18.0	47	17	17	19	35	GR08/06S	800	630
10		06	4.0	32	17.5	48	19	17	22	41	GR10/06S	800	630	400
10		08	5.0	32	17.5	48	19	19	22	42	GR10/08S	800	630	400
12		06	4.0	34	19.5	50	22	17	24	56	GR12/06S	630	630	400
12		08	5.0	34	19.5	50	22	19	24	57	GR12/08S	630	630	400
12		10	7.0	34	19.0	51	22	22	24	59	GR12/10S	630	630	400
16		10	7.0	36	20.0	54	27	22	30	80	GR16/10S	630	400	250
16		12	8.0	36	20.0	54	27	24	30	87	GR16/12S	630	400	250
16		14	10.0	36	21.5	57	27	27	30	79	GR16/14S	630	400	250
20		10	7.0	40	22.0	60	32	22	36	129	GR20/10S	420	400	250
20		12	8.0	40	22.0	60	32	24	36	131	GR20/12S	420	400	250
20		16	12.0	42	23.0	63	32	30	36	134	GR20/16S	420	400	250
25		16	12.0	46	25.5	68	41	30	46	236	GR25/16S	420	400	250
25		20	16.0	48	25.5	71	41	36	46	235	GR25/20S	420	400	250
30		20	16.0	50	26.0	74	46	36	50	299	GR30/20S	420	400	250
30		25	20.0	52	26.5	77	46	46	50	317	GR30/25S	420	400	250
38		30	25.0	59	29.5	87	55	50	60	522	GR38/30S	420	315	200

1) Pressure shown = item deliverable

2) LL = very light series; 3) L = light series; 4) S = heavy series

$$\frac{\text{PN (bar)}}{10} = \text{PN (MPa)}$$

Delivery without nut and ring. Information on ordering complete fittings see page 17.

 *Please add the **suffixes** below according to the material/surface required.

Order code suffixes		
Material	Suffix surface and material	Example
Steel, zinc plated, Cr(VI)-free	CFX	GR16/12SCFX
Stainless Steel	71X	GR16/12S71X
Brass	MSX	GR16/12SMSX

W Union elbow

EO 24° cone end

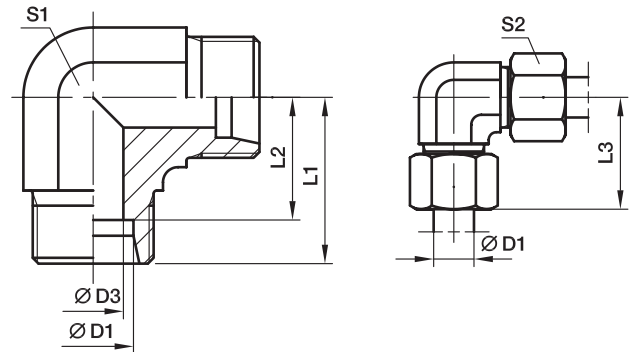

Series	D1	D3	L1	L2	L3	S1	S2	Weight g/1 piece	Order code*	PN (bar) ¹⁾		
										CF	71	MS
LL ²⁾	04	3.0	15	11.0	21	9	10	13	W04LL	100	100	63
	06	4.5	15	9.5	21	9	12	15	W06LL	100	100	63
	08	6.0	17	11.5	23	12	14	23	W08LL	100	100	63
	10	8.0	18	12.5	24	12	17	32	W10LL	100	100	63
	12	10.0	19	13.0	25	14	19	41	W12LL	100	100	63
L ³⁾	06	4.0	19	12.0	27	12	14	29	W06L	500	315	200
	08	6.0	21	14.0	29	12	17	43	W08L	500	315	200
	10	8.0	22	15.0	30	14	19	54	W10L	500	315	200
	12	10.0	24	17.0	32	19	22	80	W12L	400	315	200
	15	12.0	28	21.0	36	19	27	81	W15L	400	315	200
	18	15.0	31	23.5	40	24	32	140	W18L	400	315	200
	22	19.0	35	27.5	44	27	36	178	W22L	250	160	100
	28	24.0	38	30.5	47	36	41	340	W28L	250	160	100
	35	30.0	45	34.5	56	41	50	458	W35L	250	160	100
	42	36.0	51	40.0	63	50	60	776	W42L	250	160	100
S ⁴⁾	06	4.0	23	16.0	31	12	17	52	W06S	800	630	400
	08	5.0	24	17.0	32	14	19	74	W08S	800	630	400
	10	7.0	25	17.5	34	19	22	97	W10S	800	630	400
	12	8.0	29	21.5	38	19*	24	137	W12S	630	630	400
	16	12.0	33	24.5	43	24	30	162	W16S	630	400	250
	20	16.0	37	26.5	48	27	36	221	W20S	420	400	250
	25	20.0	42	30.0	54	36	46	424	W25S	420	400	250
	30	25.0	49	35.5	62	41	50	603	W30S	420	400	250
	38	32.0	57	41.0	72	50	60	1010	W38S	420	315	200

¹⁾ Pressure shown = item deliverable

²⁾ LL = very light series; ³⁾ L = light series; ⁴⁾ S = heavy series

*S1 = 17 in 1.4571

$$\frac{\text{PN (bar)}}{10} = \text{PN (MPa)}$$

Delivery without nut and ring. Information on ordering complete fittings see page 17.

Order code suffixes		
Material	Suffix surface and material	Example
Steel, zinc plated, Cr(VI)-free	CFX	W16SCFX
Stainless Steel	71X	W16S71X
Brass	MSX	W16SMSX

*Please add the **suffixes** below according to the material/surface required.

T Union tee

EO 24° cone end

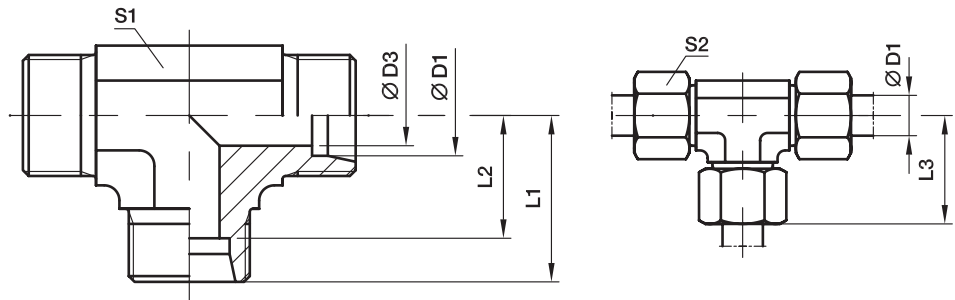

Series	D1	D3	L1	L2	L3	S1	S2	Weight g/1 piece	Order code*	PN (bar) ¹⁾			
										CF	71	MS	
LL ²⁾	04	3.0	15	11.0	21	9	10	19	T04LL	100	100	63	
	06	4.5	15	9.5	21	9	12	20	T06LL	100	100	63	
	08	6.0	17	11.5	23	12	14	27	T08LL	100	100	63	
	10	8.0	18	12.5	24	12	17	39	T10LL	100	100	63	
	12	10.0	21	15.0	27	14	19	45	T12LL	100	100	63	
L ³⁾	06	4.0	19	12.0	27	12	14	37	T06L	500	315	200	
	08	6.0	21	14.0	29	12	17	53	T08L	500	315	200	
	10	8.0	22	15.0	30	14	19	48	T10L	500	315	200	
	12	10.0	24	17.0	32	17	22	65	T12L	400	315	200	
	15	12.0	28	21.0	36	19	27	106	T15L	400	315	200	
	18	15.0	31	23.5	40	24	32	179	T18L	400	315	200	
	22	19.0	35	27.5	44	27	36	225	T22L	250	160	100	
	28	24.0	38	30.5	47	36	41	396	T28L	250	160	100	
	35	30.0	45	34.5	56	41	50	567	T35L	250	160	100	
	42	36.0	51	40.0	63	50	60	905	T42L	250	160	100	
	S ⁴⁾	06	4.0	23	16.0	31	12	17	68	T06S	800	630	400
		08	5.0	24	17.0	32	14	19	70	T08S	800	630	400
10		7.0	25	17.5	34	17	22	91	T10S	800	630	400	
12		8.0	29	21.5	38	19*	24	117	T12S	630	630	400	
16		12.0	33	24.5	43	24	30	202	T16S	630	400	250	
20		16.0	37	26.5	48	27	36	289	T20S	420	400	250	
25		20.0	42	30.0	54	36	46	545	T25S	420	400	250	
30		25.0	49	35.5	62	41	50	758	T30S	420	400	250	
38		32.0	57	41.0	72	50	60	1264	T38S	420	315	200	

1) Pressure shown = item deliverable

2) LL = very light series; 3) L = light series; 4) S = heavy series

*S1 = 17 in 1.4571

$\frac{\text{PN (bar)}}{10} = \text{PN (MPa)}$

Delivery without nut and ring. Information on ordering complete fittings see page 17.

Order code suffixes		
Material	Suffix surface and material	Example
Steel, zinc plated, Cr(VI)-free	CFX	T16SCFX
Stainless Steel	71X	T16S71X
Brass	MSX	T16SMSX

*Please add the **suffixes** below according to the material/surface required.

TR Tee Reducer

EO 24° cone end

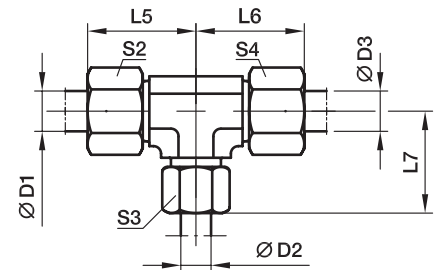
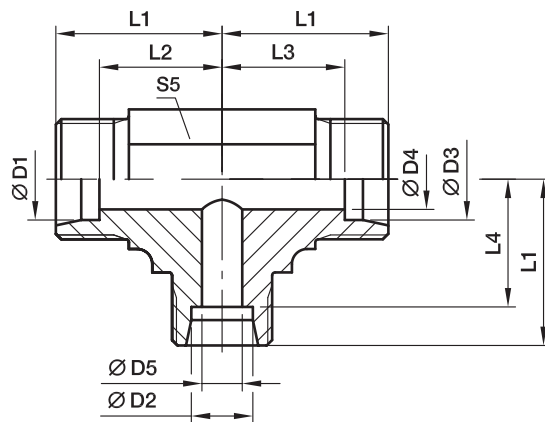
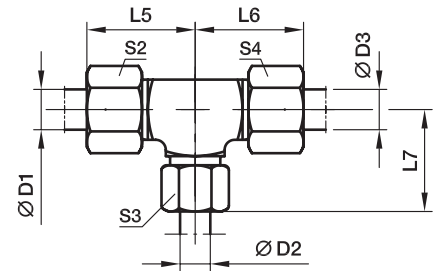

Series	D1	D2	D3	D4	D5	L1	L2	L3	L4	L5	L6	L7	S2	S3	S4	S5	Weight g/1 piece	Order code*	PN (bar ¹)		
																			CF	71	MS
LL ²⁾	04	08	04	3.0	6	17	13.0	13.0	11.5	23	23	23	10	14	10	12	27	TR04/08/04LL	100	100	63
	06	04	06	4.5	3	15	9.5	9.5	11.0	21	21	21	12	10	12	9	18	TR06/04/06LL	100	100	63
L ³⁾	06	08	06	4.0	6	21	14.0	14.0	14.0	29	29	29	14	17	14	12	54	TR06/08/06L	500	315	200
	08	06	08	6.0	4	21	14.0	14.0	14.0	29	29	29	17	14	17	12	53	TR08/06/08L	500	315	200
	06	10	06	4.0	8	22	15.0	15.0	15.0	30	30	30	14	19	14	14	53	TR06/10/06L	500	315	200
	08	10	08	6.0	8	22	15.0	15.0	15.0	30	30	30	17	19	17	14	50	TR08/10/08L	500	315	200
	10	06	10	8.0	4	22	15.0	15.0	15.0	30	30	30	19	14	19	14	46	TR10/06/10L	500	315	200
	10	08	10	8.0	6	22	15.0	15.0	15.0	30	30	30	19	17	19	14	43	TR10/08/10L	500	315	200
	10	10	06	4.0	8	22	15.0	15.0	15.0	30	30	30	19	19	14	14	49	TR10/10/06L	500	315	200
	08	12	08	6.0	10	24	17.0	17.0	17.0	32	32	32	17	22	17	17	67	TR08/12/08L	400	315	200
	12	06	12	10.0	4	24	17.0	17.0	17.0	32	32	32	22	14	22	17	66	TR12/06/12L	400	315	200
	12	08	08	6.0	6	24	17.0	17.0	17.0	32	32	32	22	17	17	17	66	TR12/08/08L	400	315	200
	12	08	12	10.0	6	24	17.0	17.0	17.0	32	32	32	22	17	22	17	68	TR12/08/12L	400	315	200
	12	10	10	8.0	8	24	17.0	17.0	17.0	32	32	32	22	19	19	17	67	TR12/10/10L	400	315	200
	12	10	12	10.0	8	24	17.0	17.0	17.0	32	32	32	22	19	22	17	67	TR12/10/12L	400	315	200
	12	12	10	8.0	10	24	17.0	17.0	17.0	32	32	32	22	22	19	17	64	TR12/12/10L	400	315	200
	10	15	10	8.0	12	28	21.0	21.0	21.0	36	36	36	19	27	19	19	105	TR10/15/10L	400	315	200
	12	15	12	10.0	12	28	21.0	21.0	21.0	36	36	36	22	27	22	19	102	TR12/15/12L	400	315	200
	15	06	15	12.0	4	28	21.0	21.0	21.0	36	36	36	27	14	27	19	107	TR15/06/15L	400	315	200
	15	10	15	12.0	8	28	21.0	21.0	21.0	36	36	36	27	19	27	19	105	TR15/10/15L	400	315	200
	15	12	12	10.0	10	28	21.0	21.0	21.0	36	36	36	27	22	22	19	101	TR15/12/12L	400	315	200
	15	12	15	12.0	10	28	21.0	21.0	21.0	36	36	36	27	22	27	19	105	TR15/12/15L	400	315	200
15	15	12	10.0	12	28	21.0	21.0	21.0	36	36	36	27	27	22	19	103	TR15/15/12L	400	315	200	
12	18	12	10.0	15	31	24.0	24.0	23.5	39	39	40	22	32	22	24	177	TR12/18/12L	400	315	200	
18	10	10	8.0	8	31	23.5	24.0	24.0	40	39	39	32	19	19	24	173	TR18/10/10L	400	315	200	
18	10	18	15.0	8	31	23.5	23.5	24.0	40	40	39	32	19	32	24	182	TR18/10/18L	400	315	200	
18	12	18	15.0	10	31	23.5	23.5	24.0	40	40	39	32	22	32	24	174	TR18/12/18L	400	315	200	

TR Tee Reducer

EO 24° cone end

Series	D1	D2	D3	D4	D5	L1	L2	L3	L4	L5	L6	L7	S2	S3	S4	S5	Weight g/1 piece	Order code*	PN (bar) ¹⁾			
																			CF	71	MS	
L ³⁾	18	15	18	15.0	12	31	23.5	23.5	24.0	40	40	39	32	27	32	24	179	TR18/15/18L	400	315	200	
	18	18	10	8.0	15	31	23.5	24.0	23.5	40	39	40	32	32	19	24	171	TR18/18/10L	400	315	200	
	22	10	22	19.0	8	35	27.5	27.5	28.0	44	44	43	36	19	36	27	232	TR22/10/22L	250	160	100	
	22	12	22	19.0	10	35	27.5	27.5	28.0	44	44	43	36	22	36	27	229	TR22/12/22L	250	160	100	
	22	15	15	12.0	12	35	27.5	28.0	28.0	44	43	43	36	27	27	27	240	TR22/15/15L	250	160	100	
	22	15	22	19.0	12	35	27.5	27.5	28.0	44	44	43	36	27	36	27	233	TR22/15/22L	250	160	100	
	22	18	18	15.0	15	35	27.5	27.5	27.5	44	44	44	36	32	32	27	236	TR22/18/18L	250	160	100	
	22	18	22	19.0	15	35	27.5	27.5	27.5	44	44	44	36	32	36	27	239	TR22/18/22L	250	160	100	
	22	22	18	15.0	19	35	27.5	27.5	27.5	44	44	44	36	36	32	27	228	TR22/22/18L	250	160	100	
	28	10	28	24.0	8	38	30.5	30.5	31.0	47	47	46	41	19	41	36	412	TR28/10/28L	250	160	100	
	28	12	28	24.0	10	38	30.5	30.5	31.0	47	47	46	41	22	41	36	408	TR28/12/28L	250	160	100	
	28	15	28	24.0	12	38	30.5	30.5	31.0	47	47	46	41	27	41	36	423	TR28/15/28L	250	160	100	
	28	18	28	24.0	15	38	30.5	30.5	30.5	47	47	47	41	32	41	36	421	TR28/18/28L	250	160	100	
	28	22	22	19.0	19	38	30.5	30.5	30.5	47	47	47	41	36	36	36	412	TR28/22/22L	250	160	100	
	28	22	28	24.0	19	38	30.5	30.5	30.5	47	47	47	41	36	41	36	415	TR28/22/28L	250	160	100	
	S ⁴⁾	10	06	10	7.0	4	25	17.5	17.5	18.0	34	34	33	22	17	22	17	103	TR10/06/10S	800	630	400
		12	08	08	5.0	5	29	21.5	22.0	22.0	38	37	37	24	19	19	19*	107	TR12/08/08S	630	630	400
		12	08	12	8.0	5	29	21.5	21.5	22.0	38	38	37	24	19	24	19*	105	TR12/08/12S	630	630	400
12		10	12	8.0	7	29	21.5	21.5	21.5	38	38	38	24	22	24	19*	114	TR12/10/12S	630	630	400	
12		16	12	8.0	12	33	25.5	25.5	24.5	42	42	43	24	30	24	24	190	TR12/16/12S	630	400	250	
16		06	16	12.0	4	33	24.5	24.5	26.0	43	43	41	30	17	30	24	176	TR16/06/16S	630	400	250	
16		08	16	12.0	5	33	24.5	24.5	26.0	43	43	41	30	19	30	24	208	TR16/08/16S	630	400	250	
16		10	16	12.0	7	33	24.5	24.5	25.5	43	43	42	30	22	30	24	210	TR16/10/16S	630	400	250	
16		12	16	12.0	8	33	24.5	24.5	25.5	43	43	42	30	24	30	24	386	TR16/12/16S	630	400	250	
16		20	16	12.0	16	37	28.5	28.5	26.5	47	47	48	30	36	30	27	296	TR16/20/16S	420	400	250	
20		10	20	16.0	7	37	26.5	26.5	29.5	48	48	46	36	22	36	27	553	TR20/10/20S	420	400	250	
20		12	20	16.0	8	37	26.5	26.5	29.5	48	48	46	36	24	36	27	306	TR20/12/20S	420	400	250	
20		16	20	16.0	12	37	26.5	26.5	28.5	48	48	47	36	30	36	27	285	TR20/16/20S	420	400	250	
20		25	20	16.0	20	42	31.5	31.5	30.0	53	53	54	36	46	36	36	544	TR20/25/20S	420	400	250	
25		16	25	20.0	12	42	30.0	30.0	33.5	54	54	52	46	30	46	36	556	TR25/16/25S	420	400	250	
25		20	25	20.0	16	42	30.0	30.0	31.5	54	54	53	46	36	46	36	544	TR25/20/25S	420	400	250	
25		30	25	20.0	25	49	37.0	37.0	35.5	61	61	62	46	50	46	41	791	TR25/30/25S	420	400	250	

¹⁾ Pressure shown = item deliverable

²⁾ LL = very light series; ³⁾ L = light series; ⁴⁾ S = heavy series

*S5 = 17 in 1.4571

PN (bar) = PN (MPa) / 10

Delivery without nut and ring. Information on ordering complete fittings see page I7.

Order code suffixes		
Material	Suffix surface and material	Example
Steel, zinc plated, Cr(VI)-free	CFX	TR16/12/16SCFX
Stainless Steel	71X	TR16/12/16S71X
Brass	MSX	TR16/12/16SMSX

*Please add the **suffixes** below according to the material/surface required.

K Union cross

EO 24° cone end

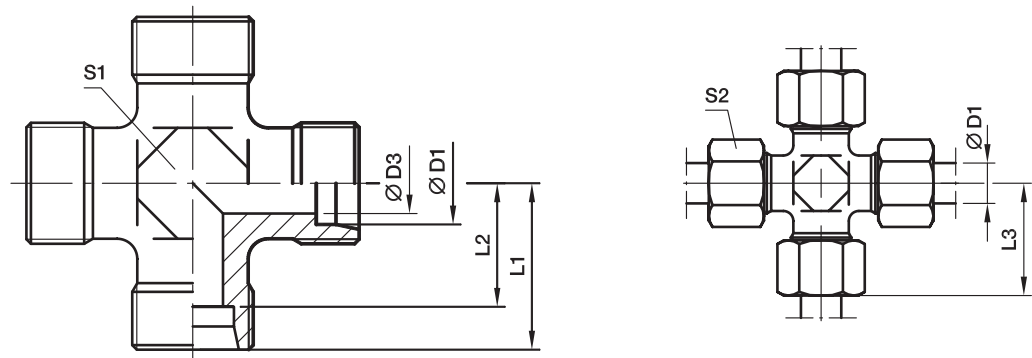

Series	D1	D3	L1	L2	L3	S1	S2	Weight g/1 piece	Order code*	PN (bar) ¹⁾		
										CF	71	MS
LL ²⁾	04	3.0	15	11.0	21	9	10	13	K04LL	100	100	63
	06	4.5	15	9.5	21	9	12	14	K06LL	100	100	63
	08	6.0	17	11.5	23	12	14	24	K08LL	100	100	63
L ³⁾	06	4.0	19	12.0	27	12	14	35	K06L	315	315	200
	08	6.0	21	14.0	29	12	17	40	K08L	315	315	200
	10	8.0	22	15.0	30	14	19	52	K10L	315	315	200
	12	10.0	24	17.0	32	17	22	69	K12L	315	315	200
	15	12.0	28	21.0	36	19	27	130	K15L	315	315	200
	18	15.0	31	23.5	40	24	32	188	K18L	315	315	200
	22	19.0	35	27.5	44	27	36	251	K22L	160	160	100
	28	24.0	38	30.5	47	36	41	392	K28L	160	160	100
	35	30.0	45	34.5	56	41	50	618	K35L	160	160	100
	42	36.0	51	40.0	63	50	60	905	K42L	160	160	100
S ⁴⁾	06	4.0	23	16.0	31	12	17	58	K06S	630	630	400
	08	5.0	24	17.0	32	14	19	82	K08S	630	630	400
	10	7.0	25	17.5	34	17	22	97	K10S	630	630	400
	12	8.0	29	21.5	38	17	24	146	K12S	630	630	400
	16	12.0	33	24.5	43	24	30	220	K16S	400	400	250
	20	16.0	37	26.5	48	27	36	339	K20S	315	315	200
	25	20.0	42	30.0	54	36	46	576	K25S	315	315	200
	30	25.0	49	35.5	62	41	50	843	K30S	315	315	200
38	32.0	57	41.0	72	50	60	1350	K38S	315	315	200	

¹⁾ Pressure shown = item deliverable

²⁾ LL = very light series; ³⁾ L = light series; ⁴⁾ S = heavy series

$$\frac{\text{PN (bar)}}{10} = \text{PN (MPa)}$$

Delivery without nut and ring. Information on ordering complete fittings see page 17.

*Please add the **suffixes** below according to the material/surface required.

Order code suffixes		
Material	Suffix surface and material	Example
Steel, zinc plated, Cr(VI)-free	CFX	K16SCFX
Stainless Steel	71X	K16S71X
Brass	MSX	K16SMSX

SV Bulkhead union

EO 24° cone end

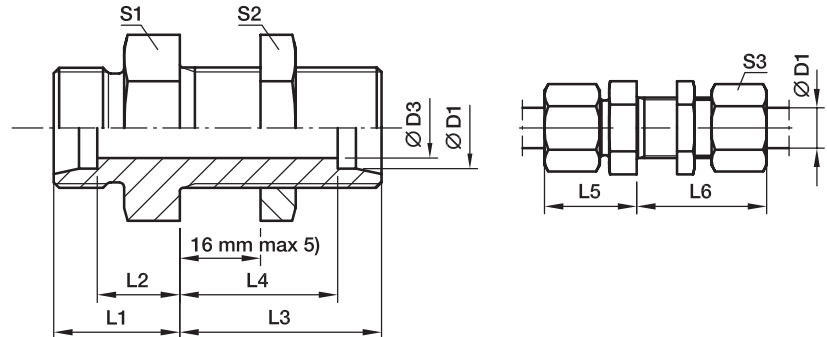

Series	D1	D3	L1	L2	L3	L4	L5	L6	S1	S2	S3	Weight g/1 piece	Order code*	PN (bar) ¹⁾		
														CF	71	MS
L ³⁾	06	4	14	7.0	34	27.0	22	42	17	17	14	39	SV06LOMD	500	315	200
	08	6	15	8.0	34	27.0	23	42	19	19	17	50	SV08LOMD	500	315	200
	10	8	17	10.0	35	28.0	25	43	22	22	19	67	SV10LOMD	500	315	200
	12	10	17	10.0	36	29.0	25	44	24	24	22	78	SV12LOMD	400	315	200
	15	12	19	12.0	38	31.0	27	46	27	30	27	128	SV15LOMD	400	315	200
	18	15	21	13.5	40	32.5	30	49	32	36	32	198	SV18LOMD	400	315	200
	22	19	24	16.5	42	34.5	33	51	36	41	36	254	SV22LOMD	250	160	100
	28	24	26	18.5	43	35.5	35	52	41	46	41	335	SV28LOMD	250	160	100
	35	30	29	18.5	47	36.5	40	58	50	55	50	546	SV35LOMD	250	160	160
	42	36	30	19.0	47	36.0	42	59	60	65	60	758	SV42LOMD	250	160	160
S ⁴⁾	06	4	19	12.0	36	29.0	27	44	19	19	17	65	SV06SOMD	800	630	400
	08	5	20	13.0	36	29.0	28	44	22	22	19	87	SV08SOMD	800	630	400
	10	7	22	14.5	37	29.5	31	46	24	24	22	112	SV10SOMD	800	630	400
	12	8	22	14.5	38	30.5	31	47	27	27	24	141	SV12SOMD	630	630	400
	16	12	25	16.5	40	31.5	35	50	32	32	30	201	SV16SOMD	630	400	250
	20	16	28	17.5	44	33.5	39	55	41	41	36	462	SV20SOMD	420	400	250
	25	20	32	20.0	47	35.0	44	59	46	46	46	492	SV25SOMD	420	400	250
	30	25	35	21.5	51	37.5	48	64	50	50	50	631	SV30SOMD	420	400	250
	38	32	38	22.0	53	37.0	53	68	65	65	60	1083	SV38SOMD	420	315	

¹⁾ Pressure shown = item deliverable

³⁾ L = light series; ⁴⁾ S = heavy series

⁵⁾ Bulkhead thickness min.

06–18 L and 06–16 S = 3 mm

22–42 L and 20–38 S = 4 mm

$\frac{\text{PN (bar)}}{10} = \text{PN (MPa)}$

Delivery without nut and ring. Information on ordering complete fittings see page 17.

Order code suffixes		
Material	Suffix surface and material	Example
Steel, zinc plated, Cr(VI)-free	CF	SV16SOMDCF
Stainless Steel	71	SV16SOMD71
Brass	MS	SV16SOMDMS

*Please add the **suffixes** below according to the material/surface required.

WSV Bulkhead elbow

EO 24° cone end

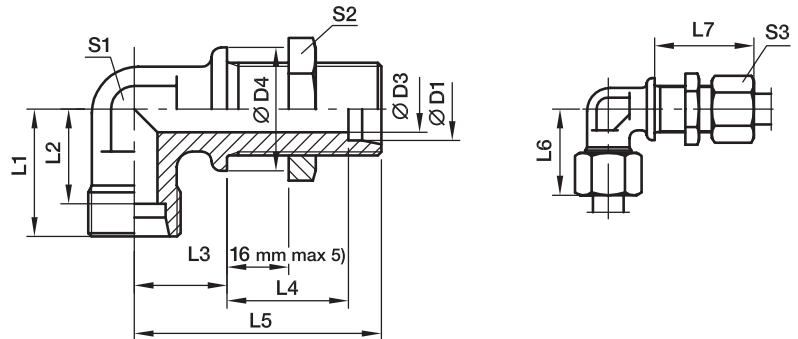

Series	D1	D3	D4	L1	L2	L3	L4	L5	L6	L7	S1	S2	S3	Weight g/1 piece	Order code*	PN (bar) ¹⁾		
																CF	71	MS
L ³⁾	06	4	17	19	12.0	14	27.0	48	27	42	12	17	14	51	WSV06LOMD	315	315	200
	08	6	19	21	14.0	17	27.0	51	29	42	12	19	17	61	WSV08LOMD	315	315	200
	10	8	22	22	15.0	18	28.0	53	30	43	14	22	19	78	WSV10LOMD	315	315	200
	12	10	24	24	17.0	20	29.0	56	32	44	17	24	22	85	WSV12LOMD	315	315	200
	15	12	27	28	21.0	23	31.0	61	36	46	19	30	27	150	WSV15LOMD	315	315	200
	18	15	32	31	23.5	24	32.5	64	40	49	24	36	32	238	WSV18LOMD	315	315	200
	22	19	36	35	27.5	30	34.5	72	44	51	27	41	36	327	WSV22LOMD	160	160	
	28	24	42	38	30.5	34	35.5	77	47	52	36	46	41	482	WSV28LOMD	160	160	
	35	30	50	45	34.5	39	36.5	86	56	58	41	55	50	729	WSV35LOMD	160	160	
	42	36	60	51	40.0	43	36.0	90	63	59	50	65	60	1091	WSV42LOMD	160	160	
S ⁴⁾	06	4	19	23	16.0	17	29.0	53	31	44	12	19	17	72	WSV06SOMD	630	630	
	08	5	22	24	17.0	18	29.0	54	32	44	14	22	19	99	WSV08SOMD	630	630	
	10	7	24	25	17.5	20	29.5	57	34	46	17	24	22	128	WSV10SOMD	630	630	
	12	8	27	29	21.5	21	30.5	59	38	47	17	27	24	168	WSV12SOMD	630	630	
	16	12	30	33	24.5	24	31.5	64	43	50	24	32	30	249	WSV16SOMD	400	400	
	20	16	36	37	26.5	30	33.5	74	48	55	27	41	36	390	WSV20SOMD	400	400	
	25	20	42	42	30.0	34	35.0	81	54	59	36	46	46	618	WSV25SOMD	400	400	
	30	25	50	49	35.5	39	37.5	90	62	64	41	50	50	889	WSV30SOMD	400	400	
	38	32	60	57	41.0	43	37.0	96	72	68	50	65	60	1337	WSV38SOMD	315	315	

¹⁾ Pressure shown = item deliverable

³⁾ L = light series; ⁴⁾ S = heavy series

⁵⁾ Bulkhead thickness min.

06-18 L and 06-16 S = 3 mm

22-42 L and 20-38 S = 4 mm

$$\frac{\text{PN (bar)}}{10} = \text{PN (MPa)}$$

Delivery without nut and ring. Information on ordering complete fittings see page I7.

*Please add the **suffixes** below according to the material/surface required.

Order code suffixes		
Material	Suffix surface and material	Example
Steel, zinc plated, Cr(VI)-free	CF	WSV16SOMDCF
Stainless Steel	71	WSV16SOMD71
Brass	MS	WSV18LOMDMS

EW Swivel nut elbow

EO 24° cone end / EO 24° DKO swivel

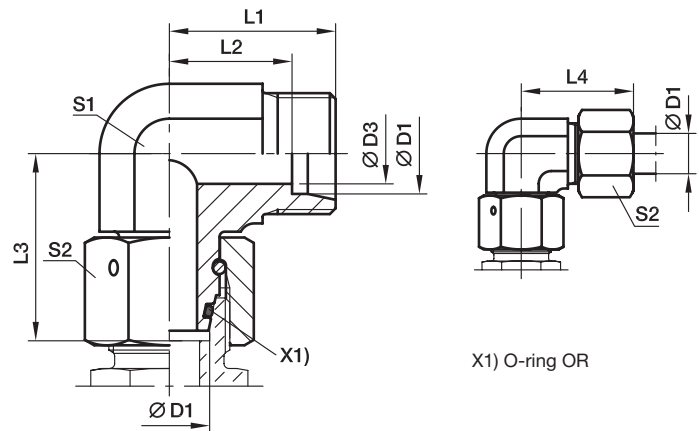

X1) O-ring OR

Series	D1	D3	L1	L2	L3	L4	S1	S2	Weight g/1 piece	Order code*	PN (bar) ¹⁾	
											CF	71
L ³⁾	06	4	19	12.0	26.0	27	12	14	34	EW06LOMD	500	315
	08	6	21	14.0	27.5	29	12	17	43	EW08LOMD	500	315
	10	8	22	15.0	29.0	30	14	19	58	EW10LOMD	500	315
	12	10	24	17.0	29.5	32	17	22	81	EW12LOMD	400	315
	15	12	28	21.0	32.5	36	19	27	128	EW15LOMD	400	315
	18	15	31	23.5	35.5	40	24	32	197	EW18LOMD	400	315
	22	19	35	27.5	38.5	44	27	36	258	EW22LOMD	250	160
	28	24	38	30.5	41.5	47	36	41	370	EW28LOMD	250	160
	35	30	45	34.5	51.0	56	41	50	593	EW35LOMD	250	160
	42	36	51	40.0	56.0	63	50	60	993	EW42LOMD	250	160
S ⁴⁾	06	4	23	16.0	27.0	31	12	17	48	EW06SOMD	800	630
	08	5	24	17.0	27.5	32	14	19	65	EW08SOMD	800	630
	10	6	25	17.5	30.0	34	17	22	92	EW10SOMD	800	630
	12	8	29	21.5	31.0	38	17	24	107	EW12SOMD	630	630
	16	12	33	24.5	36.5	43	24	30	212	EW16SOMD	630	400
	20	16	37	26.5	44.5	48	27	36	309	EW20SOMD	420	400
	25	20	42	30.0	50.0	54	36	46	547	EW25SOMD	420	400
	30	25	49	35.5	55.0	62	41	50	744	EW30SOMD	420	400
	38	32	57	41.0	63.0	72	50	60	1222	EW38SOMD	420	315

¹⁾ Pressure shown = item deliverable

³⁾ L = light series; ⁴⁾ S = heavy series

$\frac{PN \text{ (bar)}}{10} = PN \text{ (MPa)}$

Delivery without nut and ring. Information on ordering complete fittings or alternative sealing materials see page 17.

*Please add the **suffixes** below according to the material/surface required.

Order code suffixes			
Material	Suffix surface and material	Example	Standard sealing material (no additional suffix needed)
Steel, zinc plated, Cr(VI)-free	CF	EW16SOMDCF	NBR
Stainless Steel	71	EW16SOMD71	VIT

EV Swivel nut 45° elbow

EO 24° cone end / EO 24° DKO swivel

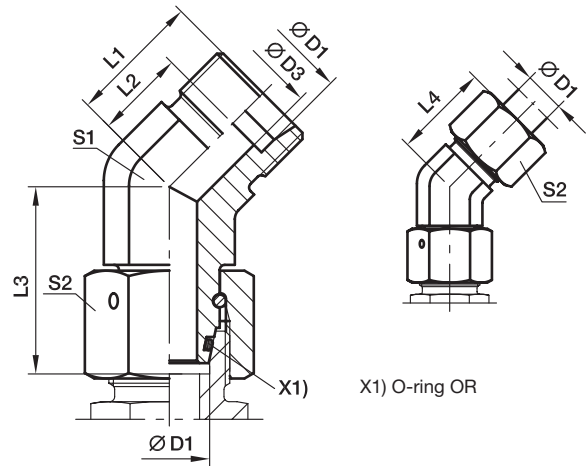

Series	D1 	D3	L1	L2	L3	L4	S1	S2	Weight g/1 piece	Order code*	PN (bar) ¹⁾	
											CF	71
L ³⁾	06	4	16.0	9.0	26.0	24	14	14	37	EV06LOMD	315	315
	08	6	19.0	12.0	27.5	27	14	17	49	EV08LOMD	315	315
	10	8	19.0	12.0	29.0	27	19	19	77	EV10LOMD	315	315
	12	10	21.0	14.0	29.5	29	19	22	86	EV12LOMD	315	315
	15	12	24.0	17.0	32.5	32	22	27	144	EV15LOMD	315	315
	18	15	24.0	16.5	35.5	33	27	32	210	EV18LOMD	315	315
	22	19	26.0	18.5	38.5	35	30	36	270	EV22LOMD	160	160
	28	24	30.5	23.0	41.5	40	36	41	385	EV28LOMD	160	160
	35	30	37.0	26.5	51.0	48	50	50	805	EV35LOMD	160	160
	42	36	37.0	26.0	56.0	49	50	60	887	EV42LOMD	160	160
S ⁴⁾	06	4	16.0	9.0	27.0	24	14	17	50	EV06SOMD	630	630
	08	5	19.0	12.0	27.5	27	19	19	80	EV08SOMD	630	630
	10	7	21.0	13.5	30.0	30	19	22	95	EV10SOMD	630	630
	12	8	24.0	16.5	31.0	33	22	24	137	EV12SOMD	630	630
	16	12	24.0	15.5	36.5	34	27	30	217	EV16SOMD	400	400
	20	16	26.5	16.0	44.5	38	30	36	313	EV20SOMD	400	400
	25	20	30.5	18.5	50.0	43	36	46	529	EV25SOMD	400	400
	30	25	37.0	23.5	55.0	50	50	50	940	EV30SOMD	400	400
	38	32	37.0	21.0	63.0	52	50	60	1055	EV38SOMD	315	315

¹⁾ Pressure shown = item deliverable

³⁾ L = light series; ⁴⁾ S = heavy series

$$\frac{\text{PN (bar)}}{10} = \text{PN (MPa)}$$

Delivery without nut and ring. Information on ordering complete fittings or alternative sealing materials see page 17.

*Please add the **suffixes** below according to the material/surface required.

Order code suffixes			
Material	Suffix surface and material	Example	Standard sealing material (no additional suffix needed)
Steel, zinc plated, Cr(VI)-free	CF	EV16SOMDCF	NBR
Stainless Steel	71	EV16SOMD71	VIT

ET Swivel nut branch tee

EO 24° cone end / EO 24° DKO swivel

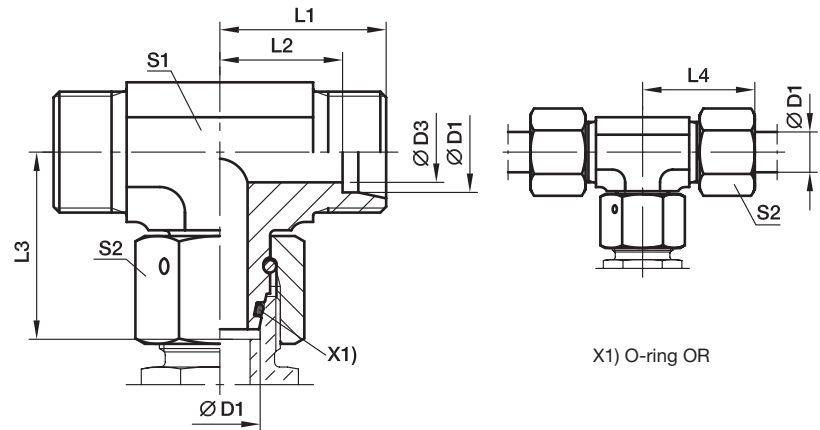

Series	D1	D3	L1	L2	L3	L4	S1	S2	Weight g/1 piece	Order code*	PN (bar) ¹⁾	
											CF	71
L ³⁾	06	4	19	12.0	26.0	27	12	14	42	ET06LOMD	500	315
	08	6	21	14.0	27.5	29	12	17	53	ET08LOMD	500	315
	10	8	22	15.0	29.0	30	14	19	71	ET10LOMD	500	315
	12	10	24	17.0	29.5	32	17	22	97	ET12LOMD	400	315
	15	12	28	21.0	32.5	36	19	27	159	ET15LOMD	400	315
	18	15	31	23.5	35.5	40	24	32	239	ET18LOMD	400	315
	22	19	35	27.5	38.5	44	27	36	308	ET22LOMD	250	160
	28	24	38	30.5	41.5	47	36	41	449	ET28LOMD	250	160
	35	30	45	34.5	51.0	56	41	50	679	ET35LOMD	250	160
	42	36	51	40.0	56.0	63	50	60	1131	ET42LOMD	250	160
S ⁴⁾	06	4	23	16.0	27.0	31	12	17	63	ET06SOMD	800	630
	08	5	24	17.0	27.5	32	14	19	79	ET08SOMD	800	630
	10	6	25	17.5	30.0	34	17	22	113	ET10SOMD	800	630
	12	8	29	21.5	31.0	38	17	24	136	ET12SOMD	630	630
	16	12	33	24.5	36.5	43	24	30	239	ET16SOMD	630	400
	20	16	37	26.5	44.5	48	27	36	388	ET20SOMD	420	400
	25	20	42	30.0	50.0	54	36	46	652	ET25SOMD	420	400
	30	25	49	35.5	55.0	62	41	50	905	ET30SOMD	420	400
	38	32	57	41.0	63.0	72	50	60	1462	ET38SOMD	420	315

¹⁾ Pressure shown = item deliverable

³⁾ L = light series; ⁴⁾ S = heavy series

$\frac{PN(\text{bar})}{10} = PN(\text{MPa})$

Delivery without nut and ring. Information on ordering complete fittings or alternative sealing materials see page 17.

*Please add the **suffixes** below according to the material/surface required.

Order code suffixes			
Material	Suffix surface and material	Example	Standard sealing material (no additional suffix needed)
Steel, zinc plated, Cr(VI)-free	CF	ET16SOMDCF	NBR
Stainless Steel	71	ET16SOMD71	VIT

EL Swivel nut run tee

EO 24° cone end / EO 24° DKO swivel

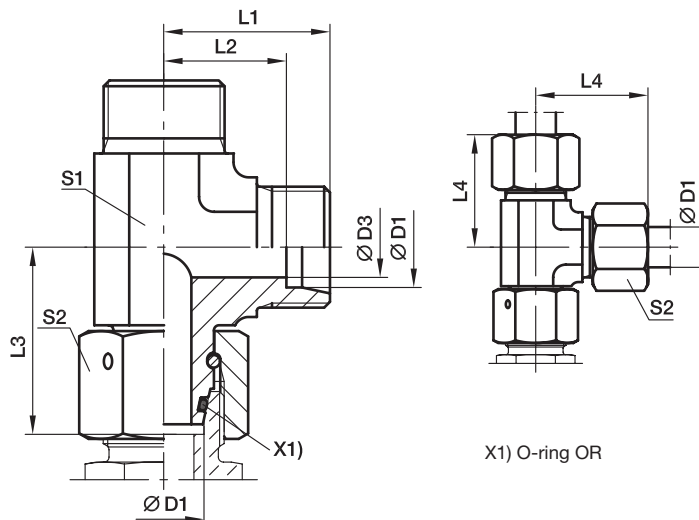

Series	D1	D3	L1	L2	L3	L4	S1	S2	Weight g/1 piece	Order code*	PN (bar) ¹⁾	
											CF	71
L ³⁾	06	4	19	12.0	26.0	27	12	14	44	EL06LOMD	500	315
	08	6	21	14.0	27.5	29	12	17	53	EL08LOMD	500	315
	10	8	22	15.0	29.0	30	14	19	68	EL10LOMD	500	315
	12	10	24	17.0	29.5	32	17	22	95	EL12LOMD	400	315
	15	12	28	21.0	32.5	36	19	27	151	EL15LOMD	400	315
	18	15	31	23.5	35.5	40	24	32	233	EL18LOMD	400	315
	22	19	35	27.5	38.5	44	27	36	309	EL22LOMD	250	160
	28	24	38	30.5	41.5	47	36	41	436	EL28LOMD	250	160
	35	30	45	34.5	51.0	56	41	50	666	EL35LOMD	250	160
	42	36	51	40.0	56.0	63	50	60	1163	EL42LOMD	250	160
S ⁴⁾	06	4	23	16.0	27.0	31	12	17	65	EL06SOMD	800	630
	08	5	24	17.0	27.5	32	14	19	84	EL08SOMD	800	630
	10	6	25	17.5	30.0	34	17	22	118	EL10SOMD	800	630
	12	8	29	21.5	31.0	38	17	24	136	EL12SOMD	630	630
	16	12	33	24.5	36.5	43	24	30	260	EL16SOMD	630	400
	20	16	37	26.5	44.5	48	27	36	375	EL20SOMD	420	400
	25	20	42	30.0	50.0	54	36	46	655	EL25SOMD	420	400
	30	25	49	35.5	55.0	62	41	50	906	EL30SOMD	420	400
	38	32	57	41.0	63.0	72	50	60	1472	EL38SOMD	420	315

¹⁾ Pressure shown = item deliverable

³⁾ L = light series; ⁴⁾ S = heavy series

$$\frac{PN \text{ (bar)}}{10} = PN \text{ (MPa)}$$

Delivery without nut and ring. Information on ordering complete fittings or alternative sealing materials see page 17.

*Please add the **suffixes** below according to the material/surface required.

Order code suffixes			
Material	Suffix surface and material	Example	Standard sealing material (no additional suffix needed)
Steel, zinc plated, Cr(VI)-free	CF	EL16SOMDCF	NBR
Stainless Steel	71	EL16SOMD71	VIT

EVW Standpipe elbow

EO 24° cone end / EO stand pipe adjustable

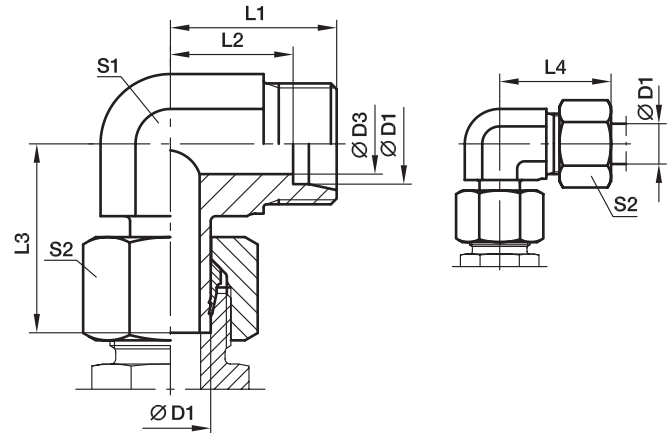

With pre-assembled nut and progressive ring for connection.
Final assembly (in appropriate body) at least 1/4 turn beyond the point of clearly perceptible resistance.

Series	D1	D3	L1	L2	L3	L4	S1	S2	Weight g/1 piece	Order code*	PN (bar) ¹⁾		
											CF	71	MS
L ³⁾	06	4	19	12.0	26.0	27	12	14	32	EVW06LOMD	315	315	200
	08	6	21	14.0	27.5	29	12	17	40	EVW08LOMD	315	315	200
	10	8	22	15.0	29.0	30	14	19	54	EVW10LOMD	315	315	200
	12	10	24	17.0	29.5	32	17	22	76	EVW12LOMD	315	315	200
	15	12	28	21.0	32.5	36	19	27	119	EVW15LOMD	315	315	200
	18	15	31	23.5	35.5	40	24	32	192	EVW18LOMD	315	315	200
	22	19	35	27.5	38.5	44	27	36	355	EVW22LOMD	160	160	100
	28	24	38	30.5	42.0	47	36	41	514	EVW28LOMD	160	160	100
	35	30	45	34.5	51.0	56	41	50	536	EVW35LOMD	160	160	100
	42	36	51	40.0	60.0	63	50	60	977	EVW42LOMD	160	160	100
S ⁴⁾	06	4	23	16.0	27.0	31	12	17	44	EVW06SOMD	630	630	400
	08	5	24	17.0	27.5	32	14	19	63	EVW08SOMD	630	630	400
	10	7	25	17.5	31.0	34	17	22	95	EVW10SOMD	630	630	400
	12	8	29	21.5	31.0	38	17	24	110	EVW12SOMD	630	630	400
	16	12	33	24.5	37.5	43	24	30	211	EVW16SOMD	400	400	250
	20	16	37	26.5	44.5	48	27	36	306	EVW20SOMD	400	400	250
	25	20	42	30.0	50.0	54	36	46	558	EVW25SOMD	400	400	250
	30	25	49	35.5	55.0	62	41	50	724	EVW30SOMD	400	400	250
	38	32	57	41.0	66.5	72	50	60	1307	EVW38SOMD	315	315	200

¹⁾ Pressure shown = item deliverable

³⁾ L = light series; ⁴⁾ S = heavy series

$\frac{PN(\text{bar})}{10} = PN(\text{MPa})$

The use of the swivel nut fitting EW is to be preferred (see page I27).

Delivery without nut and ring. Information on ordering complete fittings see page I7.

*Please add the **suffixes** below according to the material/surface required.

Order code suffixes		
Material	Suffix surface and material	Example
Steel, zinc plated, Cr(VI)-free	CF	EVW16SOMDCF
Stainless Steel	71	EVW16SOMD71
Brass	MS	EVW16SOMDMS

EVT Standpipe branch tee

EO 24° cone end / EO stand pipe adjustable

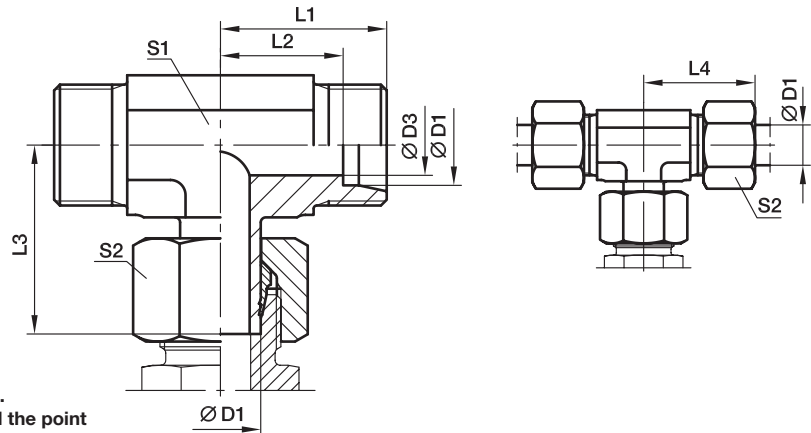

With pre-assembled nut and progressive ring for connection.
Final assembly (in appropriate body) at least 1/4 turn beyond the point of clearly perceptible resistance.

Series	D1	D3	L1	L2	L3	L4	S1	S2	Weight g/1 piece	Order code*	PN (bar) ¹⁾		
											CF	71	MS
L ³⁾	06	4	19	12.0	26.0	27	12	14	37	EVT06LOMD	315	315	200
	08	6	21	14.0	27.5	29	12	17	49	EVT08LOMD	315	315	200
	10	8	22	15.0	29.0	30	14	19	66	EVT10LOMD	315	315	200
	12	10	24	17.0	30.5	32	17	22	93	EVT12LOMD	315	315	200
	15	12	28	21.0	32.5	36	19	27	146	EVT15LOMD	315	315	200
	18	15	31	23.5	35.5	40	24	32	201	EVT18LOMD	315	315	200
	22	19	35	27.5	38.5	44	27	36	274	EVT22LOMD	160	160	
	28	24	38	30.5	43.5	47	36	41	441	EVT28LOMD	160	160	
	35	30	45	34.5	54.5	56	41	50	633	EVT35LOMD	160	160	
	42	36	51	40.0	60.0	63	50	60	1129	EVT42LOMD	160	160	
S ⁴⁾	06	4	23	16.0	27.0	31	12	17	61	EVT06SOMD	630	630	
	08	5	24	17.0	29.0	32	14	19	44	EVT08SOMD	630	630	
	10	7	25	17.5	31.0	34	17	22	84	EVT10SOMD	630	630	
	12	8	29	21.5	33.0	38	17	24	131	EVT12SOMD	630	630	
	16	12	33	24.5	37.5	43	24	30	240	EVT16SOMD	400	400	
	20	16	37	26.5	44.5	48	27	36	345	EVT20SOMD	400	400	
	25	20	42	30.0	50.5	54	36	46	647	EVT25SOMD	400	400	
	30	25	49	35.5	56.5	62	41	50	873	EVT30SOMD	400	400	
	38	32	57	41.0	66.5	72	50	60	1361	EVT38SOMD	315	315	

¹⁾ Pressure shown = item deliverable

³⁾ L = light series; ⁴⁾ S = heavy series

$$\frac{\text{PN (bar)}}{10} = \text{PN (MPa)}$$

The use of the swivel nut fitting ET is to be preferred (see page I29).

Delivery without nut and ring. Information on ordering complete fittings see page I7.

*Please add the **suffixes** below according to the material/surface required.

Order code suffixes		
Material	Suffix surface and material	Example
Steel, zinc plated, Cr(VI)-free	CF	EVT16SOMDCF
Stainless Steel	71	EVT16SOMD71
Brass	MS	EVT18LOMDMS

EVL standpipe run tee

EO 24° cone end / EO stand pipe adjustable

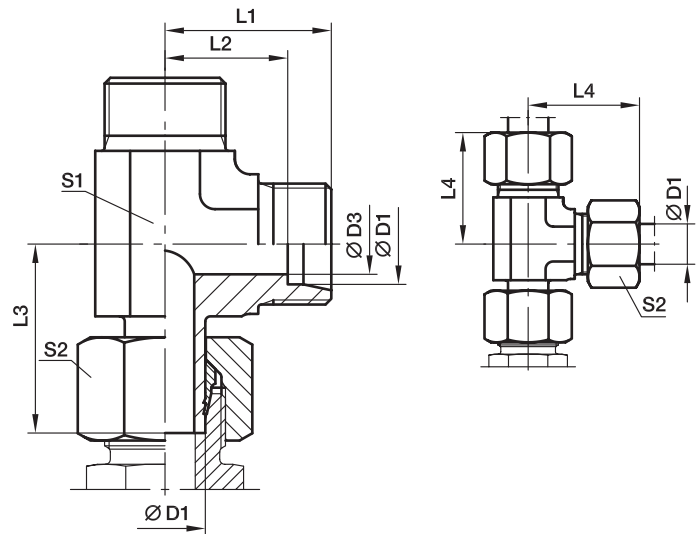

With pre-assembled nut and progressive ring for connection.
Final assembly (in appropriate body) at least 1/4 turn beyond the point of clearly perceptible resistance.

Series	D1	D3	L1	L2	L3	L4	S1	S2	Weight g/1 piece	Order code*	PN (bar) ¹⁾		
											CF	71	MS
L ³⁾	06	4	19	12.0	26.0	27	12	14	40	EVL06LOMD	315	315	200
	08	6	21	14.0	27.5	29	12	17	50	EVL08LOMD	315	315	200
	10	8	22	15.0	29.0	30	14	19	64	EVL10LOMD	315	315	200
	12	10	24	17.0	30.5	32	17	22	93	EVL12LOMD	315	315	200
	15	12	28	21.0	32.5	36	19	27	147	EVL15LOMD	315	315	200
	18	15	31	23.5	35.5	40	24	32	229	EVL18LOMD	315	315	200
	22	19	35	27.5	39.0	44	27	36	296	EVL22LOMD	160	160	
	28	24	38	30.5	43.5	47	36	41	416	EVL28LOMD	160	160	
	35	30	45	34.5	54.5	56	41	50	661	EVL35LOMD	160	160	
	42	36	51	40.0	60.0	63	50	60	1105	EVL42LOMD	160	160	
S ⁴⁾	06	4	23	16.0	27.0	31	12	17	57	EVL06SOMD	630	630	
	08	5	24	17.0	29.0	32	14	19	84	EVL08SOMD	630	630	
	10	7	25	17.5	32.0	34	17	22	116	EVL10SOMD	630	630	
	12	8	29	21.5	33.0	38	17	24	137	EVL12SOMD	630	630	
	16	12	33	24.5	37.5	43	24	30	259	EVL16SOMD	400	400	
	20	16	37	26.5	44.5	48	27	36	371	EVL20SOMD	400	400	
	25	20	42	30.0	50.5	54	36	46	647	EVL25SOMD	400	400	
	30	25	49	35.5	56.5	62	41	50	906	EVL30SOMD	400	400	
38	32	57	41.0	66.5	72	50	60	1549	EVL38SOMD	315	315		

¹⁾ Pressure shown = item deliverable

³⁾ L = light series; ⁴⁾ S = heavy series

$\frac{\text{PN (bar)}}{10} = \text{PN (MPa)}$

The use of the swivel nut fitting EL is to be preferred (see page I30).

Delivery without nut and ring. Information on ordering complete fittings see page I7.

*Please add the **suffixes** below according to the material/surface required.

Order code suffixes		
Material	Suffix surface and material	Example
Steel, zinc plated, Cr(VI)-free	CF	EVL16SOMDCF
Stainless Steel	71	EVL16SOMD71
Brass	MS	EVL18LOMDMS

DA Distance piece adapter

EO 24° DKO swivel / EO 24° cone end

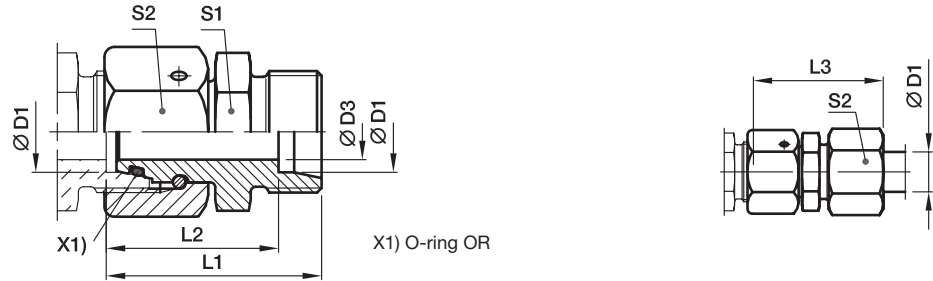

Series	D1	D3	L1	L2	L3	S1	S2	Weight g/1 piece	Order code*	PN (bar) ¹⁾		
										CF	71	MS
L ³⁾	06	2.5	43.0	36	51	12	14	33	DA06LOMD	500	315	200
	08	4.0	43.0	36	51	14	17	46	DA08LOMD	500	315	200
	10	6.0	43.0	36	51	17	19	60	DA10LOMD	500	315	200
	12	8.0	43.0	36	51	19	22	75	DA12LOMD	400	315	200
	15	10.0	43.0	36	51	24	27	118	DA15LOMD	400	315	200
	18	13.0	43.5	36	52	27	32	153	DA18LOMD	400	315	200
	22	17.0	47.5	40	56	32	36	210	DA22LOMD	250	160	100
	28	22.0	47.5	40	57	41	41	279	DA28LOMD	250	160	100
	35	28.0	60.5	50	72	46	50	468	DA35LOMD	250	160	100
	42	34.0	71.0	60	83	55	60	802	DA42LOMD	250	160	100
S ⁴⁾	06	2.5	43.0	36	51	14	17	48	DA06SOMD	800	630	400
	08	4.0	43.0	36	51	17	19	64	DA08SOMD	800	630	400
	10	6.0	43.5	36	52	19	22	81	DA10SOMD	800	630	400
	12	8.0	43.5	36	52	22	24	97	DA12SOMD	630	630	400
	16	11.0	48.5	40	58	27	30	166	DA16SOMD	630	400	250
	20	14.0	56.5	46	68	32	36	265	DA20SOMD	420	400	250
	25	18.0	62.0	50	74	41	46	466	DA25SOMD	420	400	250
	30	23.0	69.5	56	83	46	50	601	DA30SOMD	420	400	250
38	30.0	76.0	60	91	55	60	871	DA38SOMD	420	315	200	

¹⁾ Pressure shown = item deliverable

³⁾ L = light series; ⁴⁾ S = heavy series

$$\frac{\text{PN (bar)}}{10} = \text{PN (MPa)}$$

Delivery without nut and ring. Information on ordering complete fittings or alternative sealing materials see page 17.

*Please add the **suffixes** below according to the material/surface required.

Order code suffixes			
Material	Suffix surface and material	Example	Standard sealing material (no additional suffix needed)
Steel, zinc plated, Cr(VI)-free	CF	DA16SOMDCF	NBR
Stainless Steel	71	DA16SOMD71	VIT
Brass	MS	DA16SOMDMS	NBR

RED Tube end reducer

EO 24° DKO swivel / EO 24° cone end

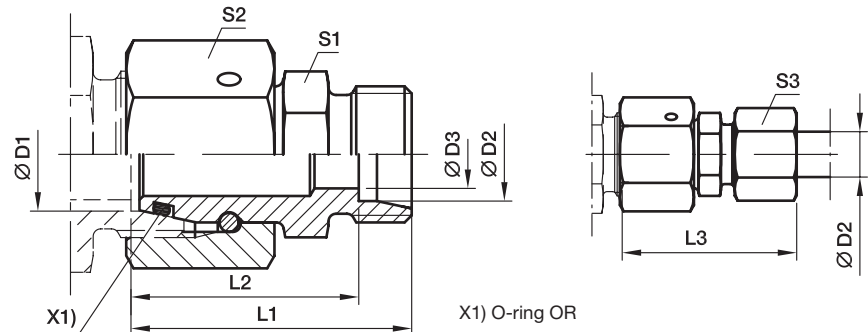

Series 2) 3) 4)	D1	D2	D3	L1	L2	L3	S1	S2	S3	Weight g/1 piece	Order code*	PN (bar) ¹⁾	
												CF	71
L/LL	06	04	2.5	28.5	24.5	34.0	9	14	10	17	RED06L/04LLOMD	100	100
L	08	06	4.0	30.5	23.5	38.0	12	17	14	29	RED08/06LOMD	500	315
L	10	06	4.0	32.0	25.0	40.0	14	19	14	36	RED10/06LOMD	500	315
L	10	08	6.0	32.0	25.0	40.0	14	19	17	38	RED10/08LOMD	500	315
L	12	06	4.0	32.0	25.0	40.0	17	22	14	49	RED12/06LOMD	400	315
L	12	08	6.0	32.0	25.0	40.0	17	22	17	49	RED12/08LOMD	400	315
L	12	10	8.0	33.0	26.0	41.0	17	22	19	51	RED12/10LOMD	400	315
L	15	06	4.0	35.5	28.5	43.0	19	27	14	81	RED15/06LOMD	400	315
L	15	08	6.0	35.5	28.5	43.0	19	27	17	85	RED15/08LOMD	400	315
L	15	10	8.0	36.5	29.5	44.0	19	27	19	83	RED15/10LOMD	400	315
L	15	12	10.0	36.5	29.5	44.0	19	27	22	83	RED15/12LOMD	400	315
L	18	06	4.0	35.0	28.0	43.0	24	32	14	109	RED18/06LOMD	400	315
L	18	08	6.0	35.0	28.0	43.0	24	32	17	111	RED18/08LOMD	400	315
L	18	10	8.0	36.0	29.0	44.0	24	32	19	110	RED18/10LOMD	400	315
L	18	12	10.0	36.0	29.0	44.0	24	32	22	110	RED18/12LOMD	400	315
L	18	15	12.0	37.0	30.0	45.0	24	32	27	115	RED18/15LOMD	400	315
L/S	18	16	12.0	40.0	31.5	49.5	27	32	30	138	RED18L/16SOMD	400	315
L	22	06	4.0	39.0	32.0	47.0	27	36	14	158	RED22/06LOMD	250	160
L	22	08	6.0	39.0	32.0	47.0	27	36	17	158	RED22/08LOMD	250	160
L	22	10	8.0	40.0	33.0	48.0	27	36	19	159	RED22/10LOMD	250	160
L	22	12	10.0	40.0	33.0	48.0	27	36	22	157	RED22/12LOMD	250	160
L	22	15	12.0	41.0	34.0	49.0	27	36	27	164	RED22/15LOMD	250	160
L/S	22	16	12.0	43.0	34.5	52.5	27	36	30	173	RED22L/16SOMD	250	160
L	22	18	15.0	41.0	33.5	50.0	27	36	32	167	RED22/18LOMD	250	160
L/S	22	20	16.0	45.0	34.5	56.0	32	36	36	203	RED22L/20SOMD	250	160
L	28	06	4.0	41.0	34.0	49.0	32	41	14	219	RED28/06LOMD	250	160
L	28	08	6.0	41.0	34.0	49.0	32	41	17	221	RED28/08LOMD	250	160
L	28	10	8.0	42.0	35.0	50.0	32	41	19	213	RED28/10LOMD	250	160
L	28	12	10.0	42.0	35.0	50.0	32	41	22	213	RED28/12LOMD	250	160
L	28	15	12.0	43.0	36.0	51.0	32	41	27	218	RED28/15LOMD	250	160
L/S	28	16	12.0	45.0	36.5	54.5	32	41	30	227	RED28L/16SOMD	250	160
L	28	18	15.0	43.0	35.5	52.0	32	41	32	220	RED28/18LOMD	250	160
L	28	22	19.0	45.0	37.5	54.0	32	41	36	222	RED28/22LOMD	250	160
L/S	28	25	20.0	50.0	38.0	62.0	41	41	46	300	RED28L/25SOMD	250	160
L	35	06	4.0	44.0	37.0	52.0	41	50	14	318	RED35/06LOMD	250	160
L	35	08	6.0	44.0	37.0	52.0	41	50	17	318	RED35/08LOMD	250	160
L	35	10	8.0	45.0	38.0	53.0	41	50	19	318	RED35/10LOMD	250	160
L	35	12	10.0	45.0	38.0	53.0	41	50	22	324	RED35/12LOMD	250	160
L	35	15	12.0	46.0	39.0	54.0	41	50	27	328	RED35/15LOMD	250	160
L	35	18	15.0	46.0	38.5	55.0	41	50	32	328	RED35/18LOMD	250	160
L	35	22	19.0	48.0	40.5	57.0	41	50	36	331	RED35/22LOMD	250	160

RED Tube end reducer

EO 24° DKO swivel / EO 24° cone end

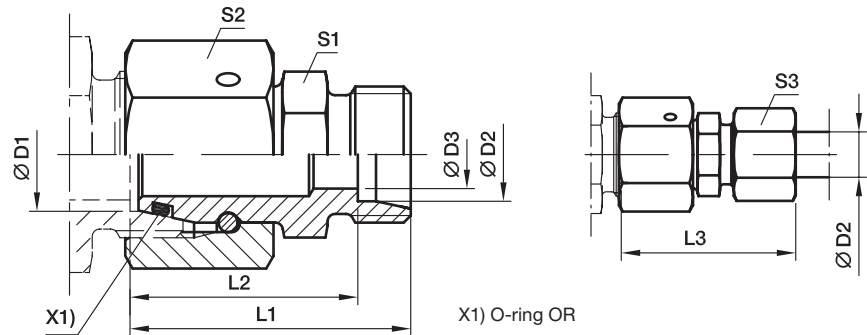

Series ²⁾ ³⁾ ⁴⁾	D1	D2	D3	L1	L2	L3	S1	S2	S3	Weight g/1 piece	Order code*	PN (bar) ¹⁾	
												CF	71
L/S	35	25	20.0	52.0	40.0	64.0	41	50	46	366	RED35L/25SOMD	250	160
L	35	28	24.0	48.0	40.5	57.0	41	50	41	327	RED35/28LOMD	250	160
L/S	35	30	25.0	55.0	41.5	68.0	46	50	50	435	RED35L/30SOMD	250	160
L	42	10	8.0	48.5	41.5	56.0	50	60	19	537	RED42/10LOMD	250	160
L	42	12	10.0	48.5	41.5	56.0	50	60	22	538	RED42/12LOMD	250	160
L	42	15	12.0	49.5	42.5	58.0	50	60	27	534	RED42/15LOMD	250	160
L	42	18	15.0	49.5	42.0	58.0	50	60	32	544	RED42/18LOMD	250	160
L	42	22	19.0	51.5	44.0	60.0	50	60	36	543	RED42/22LOMD	250	160
L	42	28	24.0	51.5	44.0	61.0	50	60	41	539	RED42/28LOMD	250	160
L/S	42	30	25.0	57.5	44.0	70.5	50	60	50	588	RED42L/30SOMD	250	160
L	42	35	30.0	53.5	43.0	65.0	50	60	50	541	RED42/35LOMD	250	160
L/S	42	38	32.0	61.5	45.5	76.0	55	60	60	701	RED42L/38SOMD	250	160

¹⁾ Pressure shown = item deliverable

²⁾ LL = very light series; ³⁾ L = light series; ⁴⁾ S = heavy series

$$\frac{\text{PN (bar)}}{10} = \text{PN (MPa)}$$

Delivery without nut and ring. Information on ordering complete fittings or alternative sealing materials see page 17.

*Please add the **suffixes** below according to the material/surface required.

Order code suffixes			
Material	Suffix surface and material	Example	Standard sealing material (no additional suffix needed)
Steel, zinc plated, Cr(VI)-free	CF	RED18/15LOMDCF	NBR
Stainless Steel	71	RED18/15LOMD71	VIT

RED Tube end reducer

EO 24° DKO swivel / EO 24° cone end

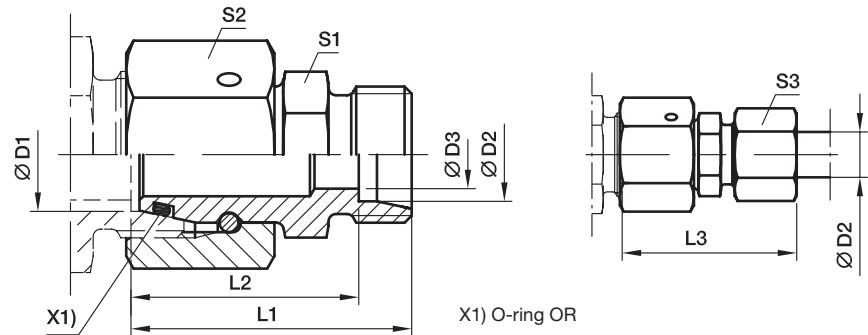

Series ^{3) 4)}	D1	D2	D3	L1	L2	L3	S1	S2	S3	Weight g/1 piece	Order code*	PN (bar) ¹⁾	
												CF	71
S	08	06	4	34.0	27.0	42	14	19	17	42	RED08/06SOMD	800	630
S	10	06	4	34.5	27.5	42	17	22	17	55	RED10/06SOMD	800	630
S	10	08	5	34.5	27.5	42	17	22	19	58	RED10/08SOMD	800	630
S	12	06	4	36.0	29.0	44	17	24	17	66	RED12/06SOMD	630	630
S	12	08	5	36.0	29.0	44	17	24	19	68	RED12/08SOMD	630	630
S	12	10	7	37.0	29.5	46	19	24	22	75	RED12/10SOMD	630	630
S	16	06	4	39.0	32.0	47	22	30	17	112	RED16/06SOMD	630	400
S	16	08	5	39.0	32.0	47	22	30	19	114	RED16/08SOMD	630	400
S	16	10	7	39.0	31.5	48	22	30	22	115	RED16/10SOMD	630	400
S	16	12	8	39.0	31.5	48	22	30	24	118	RED16/12SOMD	630	400
S/L	16	15	11	39.0	32.0	47	24	30	27	120	RED16S/15LOMD	400	315
S	20	06	4	43.0	36.0	51	27	36	17	172	RED20/06SOMD	420	400
S	20	08	5	43.0	36.0	51	27	36	19	174	RED20/08SOMD	420	400
S	20	10	7	43.0	35.5	52	27	36	22	174	RED20/10SOMD	420	400
S	20	12	8	43.0	35.5	52	27	36	24	177	RED20/12SOMD	420	400
S/L	20	15	12	43.0	36.0	51	27	36	27	173	RED20S/15LOMD	400	315
S	20	16	12	45.0	36.5	55	27	36	30	182	RED20/16SOMD	420	400
S/L	20	18	14	43.0	35.5	51	27	36	32	178	RED20S/18LOMD	400	315
S	25	06	4	45.5	38.5	53	32	46	17	294	RED25/06SOMD	420	400
S	25	08	5	45.5	38.5	53	32	46	19	295	RED25/08SOMD	420	400
S	25	10	7	45.5	38.0	54	32	46	22	296	RED25/10SOMD	420	400
S	25	12	8	45.5	38.0	54	32	46	24	299	RED25/12SOMD	420	400
S	25	16	12	47.5	39.0	57	32	46	30	304	RED25/16SOMD	420	400
S/L	25	18	15	45.5	38.0	54	32	46	32	299	RED25S/18LOMD	400	315
S	25	20	16	49.5	39.0	61	32	46	36	315	RED25/20SOMD	420	400
S/L	25	22	18	47.5	40.0	56	32	46	36	304	RED25S/22LOMD	250	160
S	30	06	4	51.0	44.0	59	41	50	17	412	RED30/06SOMD	420	400
S	30	08	5	51.0	44.0	59	41	50	19	404	RED30/08SOMD	420	400
S	30	10	7	51.0	43.5	60	41	50	22	405	RED30/10SOMD	420	400
S	30	12	8	51.0	43.5	60	41	50	24	405	RED30/12SOMD	420	400
S	30	16	12	53.0	44.5	63	41	50	30	412	RED30/16SOMD	420	400
S	30	20	16	55.0	44.5	66	41	50	36	421	RED30/20SOMD	420	400
S/L	30	22	19	53.0	45.5	61	41	50	36	406	RED30S/22LOMD	250	160
S	30	25	20	57.0	45.0	69	41	50	46	439	RED30/25SOMD	420	400
S/L	30	28	23	53.0	45.5	62	41	50	41	406	RED30S/28LOMD	250	160
S	38	06	4	54.5	47.5	62	50	60	17	556	RED38/06SOMD	420	315
S	38	08	5	54.5	47.5	62	50	60	19	581	RED38/08SOMD	420	315
S	38	10	7	54.5	47.0	63	50	60	22	579	RED38/10SOMD	420	315
S	38	12	8	54.5	47.0	63	50	60	24	577	RED38/12SOMD	420	315
S	38	16	12	56.5	48.0	66	50	60	30	580	RED38/16SOMD	420	315

RED Tube end reducer

EO 24° DKO swivel / EO 24° cone end

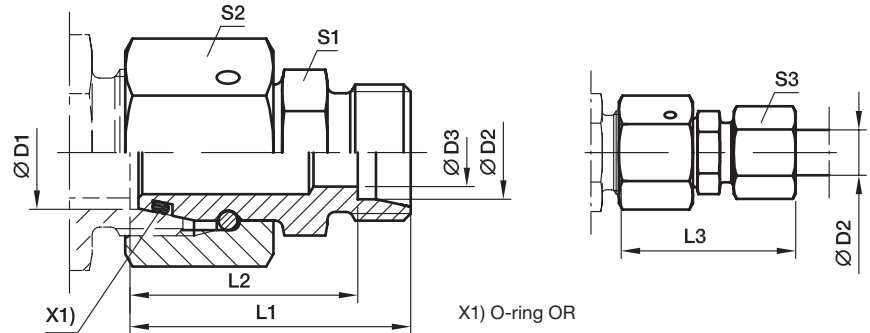

Series ^{3) 4)}	D1	D2	D3	L1	L2	L3	S1	S2	S3	Weight g/1 piece	Order code*	PN (bar) ¹⁾	
												CF	71
S	38	20	16	58.5	48.0	70	50	60	36	601	RED38/20SOMD	420	315
S	38	25	20	60.5	48.5	73	50	60	46	615	RED38/25SOMD	420	315
S/L	38	28	24	56.5	49.0	65	50	60	41	573	RED38S/28LOMD	250	160
S	38	30	25	62.5	49.0	76	50	60	50	625	RED38/30SOMD	420	315
S/L	38	35	30	58.5	48.0	69	50	60	50	588	RED38S/35LOMD	250	160

¹⁾ Pressure shown = item deliverable

³⁾ L = light series; ⁴⁾ S = heavy series

$$\frac{\text{PN (bar)}}{10} = \text{PN (MPa)}$$

Delivery without nut and ring. Information on ordering complete fittings or alternative sealing materials see page 17.

*Please add the **suffixes** below according to the material/surface required.

Order code suffixes			
Material	Suffix surface and material	Example	Standard sealing material (no additional suffix needed)
Steel, zinc plated, Cr(VI)-free	CF	RED16/12SOMDCF	NBR
Stainless Steel	71	RED16/12SOMD71	VIT

KOR Tube end reducer – Steel and Brass

EO stand pipe adjustable / EO 24° cone end

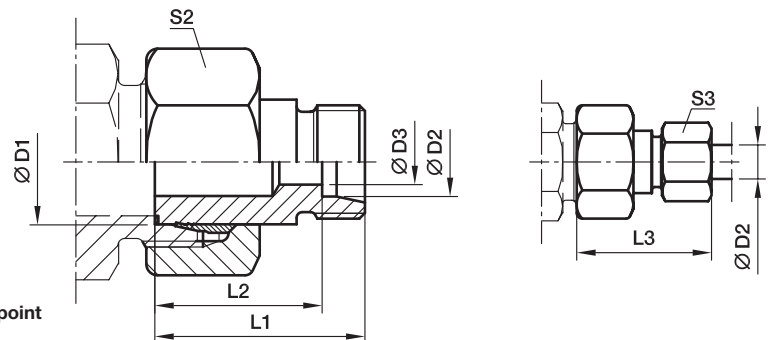

With pre-assembled nut and progressive ring for connection.
Final assembly (in appropriate body) at least 1/4 turn beyond the point of clearly perceptible resistance.

Series ^{2) 3)}	D1	D2	D3	L1	L2	L3	S2	S3	Weight g/1 piece	Order code*	PN (bar) ¹⁾	
											CF	MS
LL	06	04	3.0	28.5	24.5	34	12	10	16	KOR06/04LLOMD	100	
LL	08	04	3.0	28.5	24.5	34	14	10	16	KOR08/04LLOMD	100	
LL	08	06	4.5	23.0	17.5	29	14	12	14	KOR08/06LLOMD	100	
L/LL	06	04	3.0	28.5	24.5	34	14	10	16	KOR06L/04LLOMD	100	
L/LL	08	04	3.0	28.5	24.5	34	17	10	16	KOR08L/04LLOMD	100	
L	08	06	4.0	30.5	23.5	38	17	14	27	KOR08/06LOMD	315	200
L/LL	10	04	3.0	28.5	24.5	34	19	10	32	KOR10L/04LLOMD	100	
L	10	06	4.0	30.5	23.5	38	19	14	34	KOR10/06LOMD	315	200
L	10	08	6.0	30.5	23.5	38	19	17	35	KOR10/08LOMD	315	200
L/LL	12	04	3.0	28.5	24.5	34	22	10	41	KOR12L/04LLOMD	100	
L	12	06	4.0	30.5	23.5	38	22	14	45	KOR12/06LOMD	315	200
L	12	08	6.0	30.5	23.5	38	22	17	45	KOR12/08LOMD	315	200
L	12	10	8.0	31.5	24.5	39	22	19	46	KOR12/10LOMD	315	200
L	15	06	4.0	30.5	23.5	38	27	14	68	KOR15/06LOMD	315	200
L	15	08	6.0	30.5	23.5	38	27	17	69	KOR15/08LOMD	315	200
L	15	10	8.0	31.5	24.5	39	27	19	70	KOR15/10LOMD	315	200
L	15	12	10.0	31.5	24.5	39	27	22	70	KOR15/12LOMD	315	200
L	18	06	4.0	31.5	24.5	39	32	14	100	KOR18/06LOMD	315	200
L	18	08	6.0	31.5	24.5	39	32	17	102	KOR18/08LOMD	315	200
L	18	10	8.0	32.5	25.5	40	32	19	102	KOR18/10LOMD	315	200
L	18	12	10.0	32.5	25.5	40	32	22	101	KOR18/12LOMD	315	200
L	18	15	12.0	33.5	26.5	42	32	27	106	KOR18/15LOMD	315	200
L	22	06	4.0	32.5	25.5	40	36	14	137	KOR22/06LOMD	160	100
L	22	08	6.0	32.5	25.5	40	36	17	136	KOR22/08LOMD	160	100
L	22	10	8.0	33.5	26.5	41	36	19	138	KOR22/10LOMD	160	100
L	22	12	10.0	33.5	26.5	41	36	22	138	KOR22/12LOMD	160	100
L	22	15	12.0	34.5	27.5	43	36	27	143	KOR22/15LOMD	160	100
L	22	18	15.0	34.5	27.0	43	36	32	143	KOR22/18LOMD	160	100
L	28	06	4.0	33.5	26.5	41	41	14	177	KOR28/06LOMD	160	100
L	28	08	6.0	33.5	26.5	41	41	17	179	KOR28/08LOMD	160	100
L	28	10	8.0	34.5	27.5	42	41	19	180	KOR28/10LOMD	160	100
L	28	12	10.0	34.5	27.5	42	41	22	180	KOR28/12LOMD	160	100
L	28	15	12.0	35.5	28.5	44	41	27	185	KOR28/15LOMD	160	100
L	28	18	15.0	35.5	28.0	44	41	32	184	KOR28/18LOMD	160	100
L	28	22	19.0	37.5	30.0	46	41	36	188	KOR28/22LOMD	160	100
L	35	06	4.0	38.5	31.5	46	50	14	302	KOR35/06LOMD	160	
L	35	08	6.0	38.5	31.5	46	50	17	306	KOR35/08LOMD	160	
L	35	10	8.0	39.5	32.5	47	50	19	305	KOR35/10LOMD	160	100
L	35	12	10.0	39.5	32.5	47	50	22	304	KOR35/12LOMD	160	100
L	35	15	12.0	40.5	33.5	49	50	27	308	KOR35/15LOMD	160	100
L	35	18	15.0	40.5	33.0	49	50	32	316	KOR35/18LOMD	160	100
L	35	22	19.0	42.5	35.0	51	50	36	310	KOR35/22LOMD	160	100
L	35	28	24.0	42.5	35.0	52	50	41	305	KOR35/28LOMD	160	100

KOR Tube end reducer – Steel and Brass

EO stand pipe adjustable / EO 24° cone end

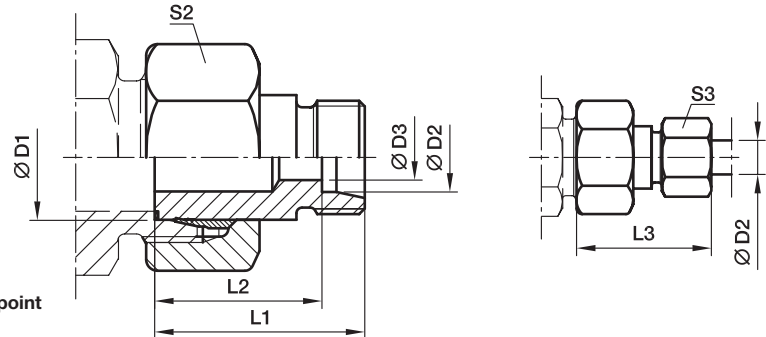

With pre-assembled nut and progressive ring for connection.
Final assembly (in appropriate body) at least 1/4 turn beyond the point of clearly perceptible resistance.

Series ^{2) 3)}	D1	D2	D3	L1	L2	L3	S2	S3	Weight g/1 piece	Order code*	PN (bar) ¹⁾	
											CF	MS
L	42	10	8.0	40.5	33.5	48	60	19	455	KOR42/10LOMD	160	
L	42	12	10.0	40.5	33.5	48	60	22	438	KOR42/12LOMD	160	
L	42	15	12.0	41.5	34.5	50	60	27	438	KOR42/15LOMD	160	100
L	42	18	15.0	41.5	34.0	50	60	32	449	KOR42/18LOMD	160	100
L	42	22	19.0	43.5	36.0	52	60	36	461	KOR42/22LOMD	160	100
L	42	28	24.0	43.5	36.0	53	60	41	443	KOR42/28LOMD	160	100
L	42	35	30.0	45.5	35.0	57	60	50	444	KOR42/35LOMD	160	100

¹⁾ Pressure shown = item deliverable

²⁾ LL = very light series; ³⁾ L = light series

$$\frac{\text{PN (bar)}}{10} = \text{PN (MPa)}$$

The use of the swivel nut fitting RED is to be preferred (see page I35).

Delivery without nut and ring. Information on ordering complete fittings see page I7.

*Please add the **suffixes** below according to the material/surface required.

Order code suffixes		
Material	Suffix surface and material	Example
Steel, zinc plated, Cr(VI)-free	CF	KOR18/15LOMDCF
Brass	MS	KOR18/15LOMDMS

KOR Tube end reducer – Steel and Brass

EO stand pipe adjustable / EO 24° cone end

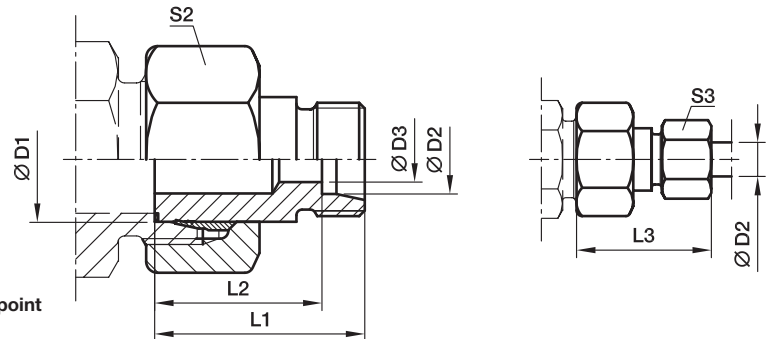

With pre-assembled nut and progressive ring for connection.
Final assembly (in appropriate body) at least 1/4 turn beyond the point of clearly perceptible resistance.

Series	D1	D2	D3	L1	L2	L3	S2	S3	Weight g/1 piece	Order code*	PN (bar) ¹⁾	
											CF	MS
S ⁴⁾	08	06	4	32	25.0	40	19	17	37	KOR08/06SOMD	630	400
	10	06	4	33	26.0	41	22	17	53	KOR10/06SOMD	630	400
	10	08	5	33	26.0	41	22	19	55	KOR10/08SOMD	630	400
	12	06	4	34	27.0	42	24	17	61	KOR12/06SOMD	630	400
	12	08	5	34	27.0	42	24	19	63	KOR12/08SOMD	630	400
	12	10	7	34	26.5	43	24	22	64	KOR12/10SOMD	630	400
	16	06	4	36	29.0	44	30	17	106	KOR16/06SOMD	400	250
	16	08	5	36	29.0	44	30	19	108	KOR16/08SOMD	400	250
	16	10	7	36	28.5	45	30	22	114	KOR16/10SOMD	400	250
	16	12	8	36	28.5	45	30	24	115	KOR16/12SOMD	400	250
	20	06	4	41	34.0	49	36	17	175	KOR20/06SOMD	400	250
	20	08	5	41	34.0	49	36	19	177	KOR20/08SOMD	400	250
	20	10	7	41	33.5	50	36	22	178	KOR20/10SOMD	400	250
	20	12	8	41	33.5	50	36	24	180	KOR20/12SOMD	400	250
	20	16	12	43	34.5	53	36	30	182	KOR20/16SOMD	400	250
	25	06	4	44	37.0	52	46	17	306	KOR25/06SOMD	400	
	25	08	5	44	37.0	52	46	19	311	KOR25/08SOMD	400	250
	25	10	7	44	36.5	53	46	22	313	KOR25/10SOMD	400	250
	25	12	8	44	36.5	53	46	24	317	KOR25/12SOMD	400	250
	25	16	12	45	36.5	55	46	30	315	KOR25/16SOMD	400	250
	25	20	16	48	37.5	59	46	36	328	KOR25/20SOMD	400	250
	30	06	4	46	39.0	54	50	17	373	KOR30/06SOMD	400	
	30	08	5	46	39.0	54	50	19	376	KOR30/08SOMD	400	
	30	10	7	46	38.5	55	50	22	376	KOR30/10SOMD	400	250
	30	12	8	46	38.5	55	50	24	377	KOR30/12SOMD	400	250
	30	16	12	48	39.5	58	50	30	381	KOR30/16SOMD	400	250
	30	20	16	50	39.5	61	50	36	386	KOR30/20SOMD	400	250
	30	25	20	52	40.0	64	50	46	406	KOR30/25SOMD	400	250
	38	06	4	50	43.0	58	60	17	571	KOR38/06SOMD	315	
	38	08	5	50	43.0	58	60	19	567	KOR38/08SOMD	315	
	38	10	7	50	42.5	59	60	22	571	KOR38/10SOMD	315	200
	38	12	8	50	42.5	59	60	24	571	KOR38/12SOMD	315	200
	38	16	12	52	43.5	62	60	30	580	KOR38/16SOMD	315	200
	38	20	16	54	43.5	65	60	36	593	KOR38/20SOMD	315	200
	38	25	20	56	44.0	68	60	46	605	KOR38/25SOMD	315	200
	38	30	25	58	44.5	71	60	50	614	KOR38/30SOMD	315	200

¹⁾ Pressure shown = item deliverable

⁴⁾ S = heavy series

$\frac{\text{PN (bar)}}{10} = \text{PN (MPa)}$

The use of the swivel nut fitting RED is to be preferred (see page I35).

Delivery without nut and ring. Information on ordering complete fittings see page I7.

*Please add the suffixes below according to the material/surface required.

Order code suffixes		
Material	Suffix surface and material	Example
Steel, zinc plated, Cr(VI)-free	CF	KOR16/10SOMDCF
Brass	MS	KOR16/10SOMDMS

KOR Tube end reducer – Stainless steel

EO stand pipe adjustable / EO 24° cone end

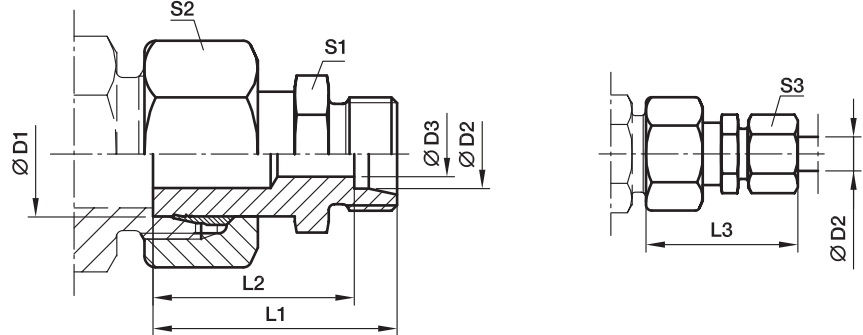

With pre-assembled nut and progressive ring for connection.
Final assembly (in appropriate body) at least 1/4 turn beyond the point of clearly perceptible resistance.

Series	D1	D2	D3	L1	L2	L3	S1	S2	S3	Weight g/1 piece	Order code*	PN (bar) ¹⁾
												71
L ³⁾	08	06	4	33.5	26.5	41	12	17	14	32	KOR08/06LOMD71	315
	10	06	4	34.5	27.5	42	12	19	14	39	KOR10/06LOMD71	315
	10	08	6	35.5	28.5	43	14	19	17	40	KOR10/08LOMD71	315
	12	06	4	36.5	29.5	44	14	22	14	49	KOR12/06LOMD71	315
	12	08	6	36.5	29.5	44	14	22	17	53	KOR12/08LOMD71	315
	12	10	8	37.5	30.5	45	17	22	19	55	KOR12/10LOMD71	315
	15	06	4	37.0	30.0	45	17	27	14	79	KOR15/06LOMD71	315
	15	08	6	37.0	30.0	45	17	27	17	78	KOR15/08LOMD71	315
	15	10	8	38.0	31.0	46	17	27	19	85	KOR15/10LOMD71	315
	15	12	10	39.0	32.0	47	19	27	22	84	KOR15/12LOMD71	315
	18	06	4	37.5	30.5	45	19	32	14	112	KOR18/06LOMD71	315
	18	08	6	37.5	30.5	45	19	32	17	113	KOR18/08LOMD71	315
	18	10	8	38.5	31.5	46	19	32	19	113	KOR18/10LOMD71	315
	18	12	10	38.5	31.5	46	19	32	22	122	KOR18/12LOMD71	315
	18	15	12	39.5	32.5	48	24	32	27	131	KOR18/15LOMD71	315
	22	06	4	38.5	31.5	46	24	36	14	154	KOR22/06LOMD71	160
	22	08	6	38.5	31.5	46	24	36	17	155	KOR22/08LOMD71	160
	22	10	8	39.5	32.5	47	24	36	19	156	KOR22/10LOMD71	160
	22	12	10	39.5	32.5	47	24	36	22	157	KOR22/12LOMD71	160
	22	15	12	40.5	33.5	49	24	36	27	160	KOR22/15LOMD71	160
	22	18	15	41.5	34.0	50	27	36	32	173	KOR22/18LOMD71	160
	28	06	4	41.0	34.0	49	30	41	14	220	KOR28/06LOMD71	160
	28	08	6	41.0	34.0	49	30	41	17	217	KOR28/08LOMD71	160
	28	10	8	42.0	35.0	50	30	41	19	211	KOR28/10LOMD71	160
	28	12	10	42.0	35.0	50	30	41	22	219	KOR28/12LOMD71	160
	28	15	12	43.0	36.0	51	30	41	27	188	KOR28/15LOMD71	160
	28	18	15	43.0	35.5	52	30	41	32	218	KOR28/18LOMD71	160
	28	22	19	45.0	37.5	54	32	41	36	228	KOR28/22LOMD71	160
35	06	4	48.5	41.5	56	36	50	14	307	KOR35/06LOMD71	160	
35	08	6	48.5	41.5	56	36	50	17	313	KOR35/08LOMD71	160	
35	10	8	49.5	42.5	57	36	50	19	370	KOR35/10LOMD71	160	
35	12	10	49.5	42.5	57	36	50	22	371	KOR35/12LOMD71	160	
35	15	12	50.5	43.5	59	36	50	27	380	KOR35/15LOMD71	160	
35	18	15	50.5	43.0	59	36	50	32	382	KOR35/18LOMD71	160	
35	22	19	52.5	45.0	61	36	50	36	380	KOR35/22LOMD71	160	
35	28	24	52.5	45.0	62	41	50	41	400	KOR35/28LOMD71	160	
42	10	8	52.5	45.5	60	46	60	19	551	KOR42/10LOMD71	160	
42	12	10	52.5	45.5	60	46	60	22	551	KOR42/12LOMD71	160	
42	15	12	53.5	46.5	62	46	60	27	687	KOR42/15LOMD71	160	
42	18	15	53.5	46.0	62	46	60	32	555	KOR42/18LOMD71	160	
42	22	19	55.5	48.0	64	46	60	36	568	KOR42/22LOMD71	160	
42	28	24	55.5	48.0	65	46	60	41	559	KOR42/28LOMD71	160	
42	35	30	57.5	47.0	69	46	60	50	588	KOR42/35LOMD71	160	

¹⁾ Pressure shown = item deliverable

³⁾ L = light series

$$\frac{\text{PN (bar)}}{10} = \text{PN (MPa)}$$

The use of the swivel nut fitting RED is to be preferred (see page I35).

Delivery without nut and ring. Information on ordering complete fittings see page I7.

KOR Tube end reducer – Stainless steel

EO stand pipe adjustable / EO 24° cone end

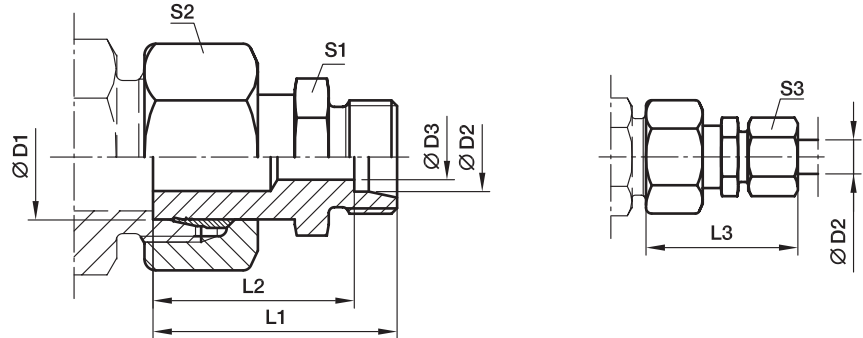

With pre-assembled nut and progressive ring for connection.
Final assembly (in appropriate body) at least 1/4 turn beyond the point of clearly perceptible resistance.

Series	D1	D2	D3	L1	L2	L3	S1	S2	S3	Weight g/1 piece	Order code*	PN (bar) ¹⁾
												71
S ⁴⁾	08	06	4	36.5	29.5	44	14	19	17	16	KOR08/06SOMD71	630
	10	06	4	38.5	31.5	46	14	22	17	16	KOR10/06SOMD71	630
	10	08	5	38.5	31.5	46	17	22	19	14	KOR10/08SOMD71	630
	12	06	4	38.5	31.5	46	14	24	17	16	KOR12/06SOMD71	630
	12	08	5	38.5	31.5	46	17	24	19	16	KOR12/08SOMD71	630
	12	10	7	39.5	32.0	48	19	24	22	27	KOR12/10SOMD71	630
	16	06	4	41.0	34.0	49	17	30	17	44	KOR16/06SOMD71	400
	16	08	5	41.0	34.0	49	17	30	19	45	KOR16/08SOMD71	400
	16	10	7	42.0	34.5	51	19	30	22	46	KOR16/10SOMD71	400
	16	12	8	42.0	34.5	51	22	30	24	68	KOR16/12SOMD71	400
	20	06	4	46.0	39.0	54	22	36	17	70	KOR20/06SOMD71	400
	20	08	5	46.0	39.0	54	22	36	19	70	KOR20/08SOMD71	400
	20	10	7	46.0	38.5	55	22	36	22	100	KOR20/10SOMD71	400
	20	12	8	46.0	38.5	55	22	36	24	101	KOR20/12SOMD71	400
	20	16	12	49.0	40.5	59	27	36	30	101	KOR20/16SOMD71	400
	25	06	4	50.5	43.5	58	27	46	17	106	KOR25/06SOMD71	400
	25	08	5	50.5	43.5	58	27	46	19	136	KOR25/08SOMD71	400
	25	10	7	50.5	43.0	59	27	46	22	136	KOR25/10SOMD71	400
	25	12	8	50.5	43.0	59	27	46	24	138	KOR25/12SOMD71	400
	25	16	12	52.5	44.0	62	27	46	30	143	KOR25/16SOMD71	400
25	20	16	54.5	44.0	66	32	46	36	143	KOR25/20SOMD71	400	
30	06	4	53.0	46.0	61	32	50	17	177	KOR30/06SOMD71	400	
30	08	5	53.0	46.0	61	32	50	19	179	KOR30/08SOMD71	400	
30	10	7	53.0	45.5	62	32	50	22	180	KOR30/10SOMD71	400	
30	12	8	53.0	45.5	62	32	50	24	180	KOR30/12SOMD71	400	
30	16	12	55.0	46.5	65	32	50	30	184	KOR30/16SOMD71	400	
30	20	16	57.0	46.5	68	32	50	36	188	KOR30/20SOMD71	400	
30	25	20	60.0	48.0	72	41	50	46	302	KOR30/25SOMD71	400	
38	06	4	60.0	53.0	68	41	60	17	306	KOR38/06SOMD71	315	
38	08	5	60.0	53.0	68	41	60	19	305	KOR38/08SOMD71	315	
38	10	7	60.0	52.5	69	41	60	22	304	KOR38/10SOMD71	315	
38	12	8	60.0	52.5	69	41	60	24	308	KOR38/12SOMD71	315	
38	16	12	62.0	53.5	72	41	60	30	310	KOR38/16SOMD71	315	
38	20	16	64.0	53.5	75	41	60	36	305	KOR38/20SOMD71	315	
38	25	20	66.0	54.0	78	41	60	46	455	KOR38/25SOMD71	315	
38	30	25	69.0	55.5	82	46	60	50	438	KOR38/30SOMD71	315	

¹⁾ Pressure shown = item deliverable

⁴⁾ S = heavy series

$\frac{\text{PN (bar)}}{10} = \text{PN (MPa)}$

The use of the swivel nut fitting RED is to be preferred (see page I35).

Delivery without nut and ring. Information on ordering complete fittings see page I7.

GZ Swivel union

EO 24° DKO swivel

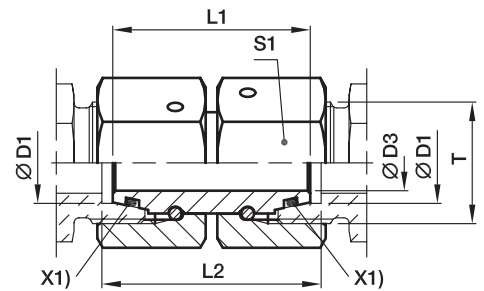

X1) O-ring OR

Series	D1 	T	D3	L1	L2	S1	Weight g/1 piece	Order code*	PN (bar) ¹⁾	
									CF	71
L ³⁾	06	M 12×1.5	2.5	33	33	14	28	GZ06L	500	315
	08	M 14×1.5	4.0	33	33	17	41	GZ08L	500	315
	10	M 16×1.5	6.0	34	34	19	53	GZ10L	500	315
	12	M 18×1.5	8.0	34	34	22	71	GZ12L	400	315
	15	M 22×1.5	10.0	39	39	27	129	GZ15L	400	315
	18	M 26×1.5	13.0	36	38	32	165	GZ18L	400	315
	22	M 30×2.0	17.0	42	44	36	243	GZ22L	250	160
	28	M 36×2.0	22.0	46	48	41	319	GZ28L	250	160
	35	M 45×2.0	28.0	48	52	50	449	GZ35L	250	160
	42	M 52×2.0	34.0	52	57	60	737	GZ42L	250	160
S ⁴⁾	06	M 14×1.5	2.5	32	33	17	41	GZ06S	800	630
	08	M 16×1.5	4.0	33	34	19	54	GZ08S	800	630
	10	M 18×1.5	6.0	33	35	22	74	GZ10S	800	630
	12	M 20×1.5	8.0	36	38	24	95	GZ12S	630	630
	16	M 24×1.5	11.0	39	42	30	172	GZ16S	630	400
	20	M 30×2.0	14.0	44	48	36	261	GZ20S	420	400
	25	M 36×2.0	18.0	46	53	46	477	GZ25S	420	400
	30	M 42×2.0	23.0	52	62	50	605	GZ30S	420	400
	38	M 52×2.0	30.0	52	67	60	826	GZ38S	420	315

¹⁾ Pressure shown = item deliverable

³⁾ L = light series; ⁴⁾ S = heavy series

$$\frac{\text{PN (bar)}}{10} = \text{PN (MPa)}$$

Information on ordering complete fittings or alternative sealing materials see page 17.

*Please add the **suffixes** below according to the material/surface required.

Order code suffixes			
Material	Suffix surface and material	Example	Standard sealing material (no additional suffix needed)
Steel, zinc plated, Cr(VI)-free	CF	GZ16SCF	NBR
Stainless Steel	71	GZ16S71	VIT

GZR Swivel reducer

EO 24° DKO swivel

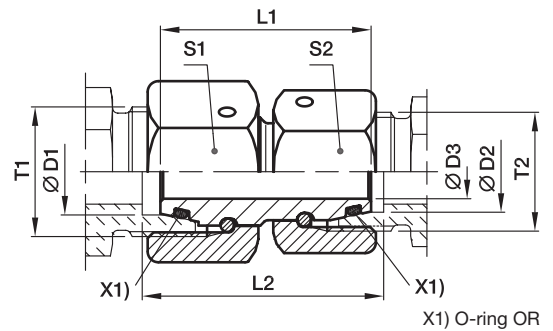

Series 3) 4)	D1 	D2 	T1	T2	D3	L1	L2	S1	S2	Weight g/1 piece	Order code*	PN (bar) ¹⁾	
												CF	71
L/S	06	06	M 14×1.5	M 12×1.5	2.5	32.5	33.0	17	14	34	GZR06L/06S	500	500
L	08	06	M 14×1.5	M 12×1.5	2.5	33.0	33.0	17	14	36	GZR08/06L	500	500
L/S	08	08	M 16×1.5	M 14×1.5	4.0	32.5	34.0	19	17	48	GZR08L/08S	500	500
L	10	06	M 16×1.5	M 12×1.5	2.5	34.0	34.0	19	14	44	GZR10/06L	500	500
L	10	08	M 16×1.5	M 14×1.5	4.0	34.0	34.0	19	17	50	GZR10/08L	500	500
L/S	10	10	M 18×1.5	M 16×1.5	6.0	34.0	34.5	22	19	63	GZR10L/10S	500	500
L	12	06	M 18×1.5	M 12×1.5	2.5	34.0	34.0	22	14	56	GZR12/06L	400	400
L	12	08	M 18×1.5	M 14×1.5	4.0	34.0	34.0	22	17	62	GZR12/08L	400	400
L	12	10	M 18×1.5	M 16×1.5	6.0	34.0	34.0	22	19	65	GZR12/10L	400	400
L/S	12	12	M 20×1.5	M 18×1.5	8.0	36.5	37.5	24	22	85	GZR12L/12S	400	400
L	15	08	M 22×1.5	M 14×1.5	4.0	39.0	39.0	27	17	98	GZR15/08L	400	400
L	15	10	M 22×1.5	M 16×1.5	6.0	39.0	39.0	27	19	101	GZR15/10L	400	400
L	15	12	M 22×1.5	M 18×1.5	8.0	39.0	39.0	27	22	108	GZR15/12L	400	400
L	18	10	M 26×1.5	M 16×1.5	6.0	37.0	37.5	32	19	125	GZR18/10L	400	400
L	18	12	M 26×1.5	M 18×1.5	8.0	36.5	37.5	32	22	132	GZR18/12L	400	400
L	18	15	M 26×1.5	M 22×1.5	10.0	38.5	38.5	32	27	155	GZR18/15L	400	400
L/S	18	16	M 26×1.5	M 24×1.5	11.0	39.0	39.0	32	30	177	GZR18L/16S	400	400
L	22	12	M 30×2.0	M 18×1.5	8.0	42.5	43.5	36	22	195	GZR22/12L	250	250
L	22	15	M 30×2.0	M 22×1.5	10.0	42.5	43.5	36	27	215	GZR22/15L	250	250
L	22	18	M 30×2.0	M 26×1.5	13.0	42.0	44.0	36	32	228	GZR22/18L	250	250
L/S	22	20	M 30×2.0	M 30×2.0	14.0	44.0	47.0	36	36	266	GZR22L/20S	250	250
L	28	15	M 36×2.0	M 22×1.5	10.0	46.5	47.5	41	27	143	GZR28/15L	250	250
L	28	18	M 36×2.0	M 26×1.5	13.0	39.5	48.0	41	32	311	GZR28/18L	250	250
L	28	22	M 36×2.0	M 30×2.0	17.0	46.0	46.0	41	36	309	GZR28/22L	250	250
L/S	28	25	M 36×2.0	M 36×2.0	18.0	46.0	50.5	41	46	419	GZR28L/25S	250	250
L	35	18	M 45×2.0	M 26×1.5	13.0	48.0	51.0	50	32	430	GZR35/18L	250	250
L	35	22	M 45×2.0	M 30×2.0	17.0	48.0	51.0	50	36	429	GZR35/22L	250	250
L	35	28	M 45×2.0	M 36×2.0	22.0	48.0	51.0	50	41	415	GZR35/28L	250	250
L/S	35	30	M 45×2.0	M 42×2.0	23.0	52.0	59.0	50	50	577	GZR35L/30S	250	250
L	42	22	M 52×2.0	M 30×2.0	17.0	52.0	55.5	60	36	653	GZR42/22L	250	250
L	42	28	M 52×2.0	M 36×2.0	22.0	52.0	55.5	60	41	648	GZR42/28L	250	250
L	42	35	M 52×2.0	M 45×2.0	28.0	52.0	56.5	60	50	662	GZR42/35L	250	250
L/S	42	38	M 52×2.0	M 52×2.0	30.0	52.0	62.0	60	60	822	GZR42L/38S	250	250
S	08	06	M 16×1.5	M 14×1.5	2.5	33.0	34.0	19	17	49	GZR08/06S	800	800
S	10	06	M 18×1.5	M 14×1.5	2.5	33.0	34.5	22	17	60	GZR10/06S	800	800
S	10	08	M 18×1.5	M 16×1.5	4.0	33.0	34.5	22	19	66	GZR10/08S	800	800
S	12	06	M 20×1.5	M 14×1.5	2.5	36.0	37.5	24	17	77	GZR12/06S	630	630
S	12	08	M 20×1.5	M 16×1.5	4.0	36.0	37.5	24	19	82	GZR12/08S	630	630
S	12	10	M 20×1.5	M 18×1.5	6.0	36.0	38.0	24	22	89	GZR12/10S	630	630
S	16	10	M 24×1.5	M 18×1.5	6.0	39.0	41.5	30	22	138	GZR16/10S	630	630
S	16	12	M 24×1.5	M 20×1.5	8.0	39.0	41.5	30	24	143	GZR16/12S	630	630
S/L	16	15	M 24×1.5	M 22×1.5	10.0	39.5	41.5	30	27	153	GZR16S/15L	400	400
S	20	12	M 30×2.0	M 20×1.5	8.0	44.0	47.0	36	24	204	GZR20/12S	420	420

GZR Swivel reducer

EO 24° DKO swivel

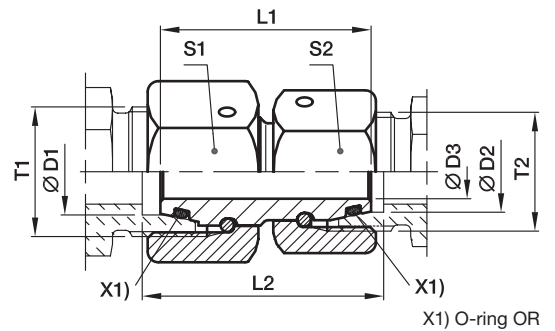

Series 3) 4)	D1	D2	T1	T2	D3	L1	L2	S1	S2	Weight g/1 piece	Order code*	PN (bar) ¹⁾	
												CF	71
S	20	16	M 30×2.0	M 24×1.5	11.0	44	47.5	36	30	232	GZR20/16S	420	420
S/L	20	18	M 30×2.0	M 26×1.5	13.0	44	47.0	36	32	224	GZR20S/18L	400	400
S	25	16	M 36×2.0	M 24×1.5	11.0	46	51.0	46	30	224	GZR25/16S	420	420
S	25	20	M 36×2.0	M 30×2.0	14.0	46	51.5	46	36	364	GZR25/20S	420	420
S/L	25	22	M 36×2.0	M 30×2.0	17.0	46	50.5	46	36	475	GZR25S/22L	250	250
S	30	16	M 42×2.0	M 24×1.5	11.0	52	58.5	50	30	475	GZR30/16S	420	420
S	30	20	M 42×2.0	M 30×2.0	14.0	52	59.0	50	36	500	GZR30/20S	420	420
S	30	25	M 42×2.0	M 36×2.0	18.0	52	60.5	50	46	589	GZR30/25S	420	420
S/L	30	28	M 42×2.0	M 36×2.0	22.0	52	58.0	50	41	476	GZR30S/28L	250	250
S	38	20	M 52×2.0	M 30×2.0	14.0	52	61.5	60	36	671	GZR38/20S	420	420
S	38	25	M 52×2.0	M 36×2.0	18.0	52	63.0	60	46	759	GZR38/25S	420	420
S	38	30	M 52×2.0	M 42×2.0	23.0	52	64.5	60	50	767	GZR38/30S	420	420
S/L	38	35	M 52×2.0	M 45×2.0	28.0	52	61.5	60	50	662	GZR38S/35L	250	250

1) Pressure shown = item deliverable

3) L = light series; 4) S = heavy series

$$\frac{PN \text{ (bar)}}{10} = PN \text{ (MPa)}$$

Information on ordering complete fittings or alternative sealing materials see page 17.

*Please add the **suffixes** below according to the material/surface required.

Order code suffixes			
Material	Suffix surface and material	Example	Standard sealing material (no additional suffix needed)
Steel, zinc plated, Cr(VI)-free	CF	GZR16/12SCF	NBR
Stainless steel	71	GZR16/12S71	VIT

GEO Male stud connector

Male metric thread – O-ring (ISO 6149) / EO 24° cone end

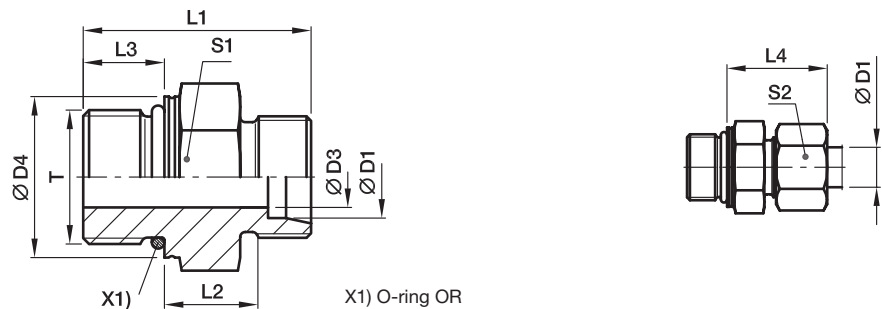

Series	D1	T	D3	D4	L1	L2	L3	L4	S1	S2	Weight g/1 piece	Order code*	PN (bar) ¹⁾	
													CF	71
LL ²⁾	04	M 08×1.0	3.0	10.8	20.0	9.5	6.5	19.0	11*	10	8	GEO04LLMOMD	100	100
	04	M 10×1.0	3.0	12.8	20.0	9.5	6.5	19.0	13	10	11	GEO04LLM10X1OMD	100	
	06	M 10×1.0	4.5	12.8	20.0	8.0	6.5	19.5	13	12	10	GEO06LLMOMD	100	
L ³⁾	06	M 10×1.0	4.5	14.0	25.0	8.5	8.5	23.0	14	14	15	GEO06LMOMD	500	315
	08	M 12×1.5	6.0	17.0	28.0	10.0	11.0	25.0	17	17	23	GEO08LMOMD	500	315
	10	M 14×1.5	7.5	19.0	29.0	11.0	11.0	26.0	19	19	28	GEO10LMOMD	500	315
	12	M 16×1.5	9.0	22.0	31.0	12.5	11.5	27.0	22	22	40	GEO12LMOMD	400	315
	15	M 18×1.5	11.0	24.0	33.0	13.5	12.5	29.0	24	27	56	GEO15LMOMD	400	315
	18	M 22×1.5	14.0	27.0	35.0	14.5	13.0	31.0	27	32	80	GEO18LMOMD	400	315
	22	M 27×2.0	18.0	32.0	40.0	16.5	16.0	33.0	32	36	104	GEO22LM27X2OMD	250	160
	28	M 33×2.0	23.0	41.0	41.0	17.5	16.0	34.0	41	41	171	GEO28LMOMD	250	160
	35	M 42×2.0	30.0	50.0	44.0	17.5	16.0	39.0	50	50	278	GEO35LMOMD	250	160
	42	M 48×2.0	36.0	55.0	47.5	19.0	17.5	42.0	55	60	340	GEO42LMOMD	250	160
S ⁴⁾	06	M 12×1.5	4.0	17.0	31.0	13.0	11.0	28.0	17	17	29	GEO06SMOMD	800	630
	08	M 14×1.5	6.0	19.0	33.0	15.0	11.0	30.0	19	19	41	GEO08SMOMD	800	630
	10	M 16×1.5	7.0	22.0	35.0	15.0	12.5	31.0	22	22	55	GEO10SMOMD	800	630
	12	M 18×1.5	9.0	24.0	38.5	17.0	14.0	33.0	24	24	73	GEO12SMOMD	630	630
	16	M 22×1.5	12.0	27.0	42.0	18.5	15.0	37.0	27	30	102	GEO16SMOMD	630	400
	20	M 27×2.0	15.0	32.0	49.5	20.5	18.5	42.0	32	36	169	GEO20SMOMD	420	400
	25	M 33×2.0	20.0	41.0	53.5	23.0	18.5	47.0	41	46	274	GEO25SMOMD	420	400
	30	M 42×2.0	26.0	50.0	56.0	23.5	19.0	50.0	50	50	412	GEO30SMOMD	420	400
	38	M 48×2.0	32.0	55.0	63.5	26.0	21.5	57.0	55	60	580	GEO38SMOMD	420	315

¹⁾ Pressure shown = item deliverable

²⁾ LL = very light series; ³⁾ L = light series; ⁴⁾ S = heavy series

$\frac{\text{PN (bar)}}{10} = \text{PN (MPa)}$

Delivery without nut and ring. Information on ordering complete fittings see page 17.

*S1=SW12 in 1.4571

*Please add the **suffixes** below according to the material/surface required.

Order code suffixes			
Material	Suffix surface and material	Example	Standard sealing material (no additional suffix needed)
Steel, zinc plated, Cr(VI)-free	CF	GEO16SMOMDCF	NBR
Stainless Steel	71	GEO16SMOMD71	VIT

GE-M-ED Male stud connector

Male metric thread – ED (ISO 9974) / EO 24° cone end

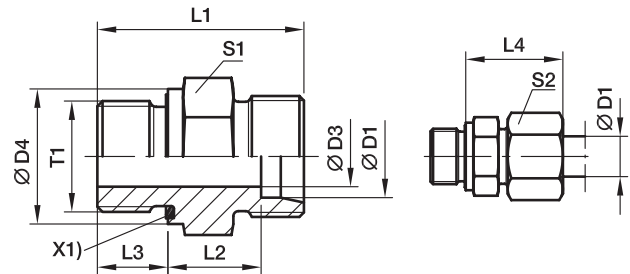

X1) Eolastic-sealing ED

Series	D1	T1	D3	D4	L1	L2	L3	L4	S1	S2	Weight g/1 piece	Order code*	PN (bar) ¹⁾	
													CF	71
L ³⁾	06	M 10×1.0	4	14	23.5	8.5	8	23	14	14	13	GE06LMEDOMD	500	315
	08	M 12×1.5	6	17	29.0	10.0	12	25	17	17	22	GE08LMEDOMD	500	315
	10	M 14×1.5	7	19	30.0	11.0	12	26	19	19	29	GE10LMEDOMD	500	315
	10	M 12×1.5	6	17	30.0	11.0	12	26	17	19	23	GE10LM12X1.5EDOMD	315	315
	10	M 16×1.5	8	22	31.5	12.5	12	27	22	19	40	GE10LM16X1.5EDOMD	420	315
	10	M 18×1.5	8	24	31.5	12.5	12	27	24	19	50	GE10LM18X1.5EDOMD	400	315
	10	M 22×1.5	8	27	35.0	14.0	14	29	27	19	80	GE10LM22X1.5EDOMD	400	315
	12	M 16×1.5	9	22	31.5	12.5	12	27	22	22	40	GE12LMEDOMD	400	315
	12	M 14×1.5	7	19	30.0	11.0	12	26	19	22	30	GE12LM14X1.5EDOMD	400	315
	12	M 18×1.5	10	24	31.5	12.5	12	27	24	22	47	GE12LM18X1.5EDOMD	400	315
	12	M 22×1.5	10	27	35.0	14.0	14	29	27	22	75	GE12LM22X1.5EDOMD	400	315
	15	M 18×1.5	11	24	32.5	13.5	12	29	24	27	51	GE15LMEDOMD	400	315
	15	M 16×1.5	9	22	32.0	13.0	12	28	24	27	64	GE15LM16X1.5EDOMD	400	315
	15	M 22×1.5	12	27	36.0	15.0	14	30	27	27	77	GE15LM22X1.5EDOMD	400	315
	18	M 22×1.5	14	27	36.0	14.5	14	31	27	32	74	GE18LMEDOMD	400	315
	18	M 18×1.5	11	24	33.5	14.0	12	30	27	32	68	GE18LM18X1.5EDOMD	400	315
	22	M 26×1.5	18	32	40.0	16.5	16	33	32	36	103	GE22LMEDOMD	250	160
	22	M 22×1.5	14	32	38.0	16.5	14	33	32	36	97	GE22LM22X1.5EDOMD	250	160
	28	M 33×2.0	23	40	43.0	17.5	18	34	41	41	168	GE28LMEDOMD	250	160
	35	M 42×2.0	30	50	48.0	17.5	20	39	50	50	281	GE35LMEDOMD	250	160
42	M 48×2.0	36	55	52.0	19.0	22	42	55	60	356	GE42LMEDOMD	250	160	
S ⁴⁾	06	M 12×1.5	4	17	32.0	13.0	12	28	17	17	30	GE06SMEDOMD	800	630
	08	M 14×1.5	5	19	34.0	15.0	12	30	19	19	42	GE08SMEDOMD	800	630
	10	M 16×1.5	7	22	34.5	15.0	12	31	22	22	54	GE10SMEDOMD	800	630
	12	M 18×1.5	8	24	36.5	17.0	12	33	24	24	71	GE12SMEDOMD	630	630
	12	M 14×1.5	5	19	36.0	16.5	12	33	22	24	60	GE12SM14X1.5EDOMD	630	630
	12	M 22×1.5	8	27	39.0	17.5	14	34	27	24	102	GE12SM22X1.5EDOMD	630	400
	16	M 22×1.5	12	27	41.0	18.5	14	37	27	30	95	GE16SMEDOMD	630	400
	16	M 18×1.5	8	24	38.5	18.0	12	36	27	30	88	GE16SM18X1.5EDOMD	630	400
	20	M 27×2.0	16	32	47.0	20.5	16	42	32	36	150	GE20SMEDOMD	420	400
	25	M 33×2.0	20	40	53.0	23.0	18	47	41	46	264	GE25SMEDOMD	420	400
	30	M 42×2.0	25	50	57.0	23.5	20	50	50	50	422	GE30SMEDOMD	420	400
	38	M 48×2.0	32	55	64.0	26.0	22	57	55	60	569	GE38SMEDOMD	420	315

¹⁾ Pressure shown = item deliverable

³⁾ L = light series; ⁴⁾ S = heavy series

$$\frac{\text{PN (bar)}}{10} = \text{PN (MPa)}$$

Delivery without nut and ring. Information on ordering complete fittings or alternative sealing materials see page 17.

*Please add the below according to the material/surface required.

Order code suffixes			
Material	Suffix surface and material	Example	Standard sealing material (no additional suffix needed)
Steel, zinc plated, Cr(VI)-free	CF	GE16SMEDOMDCF	NBR
Stainless Steel	71	GE16SMEDOMD71	VIT

GE-R-ED Male stud connector

Male BSPP thread – ED-seal (ISO 1179) / EO 24° cone end

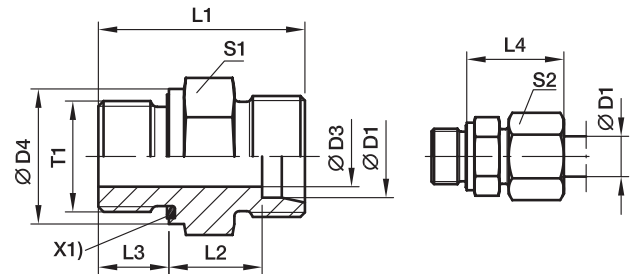

X1) Elastic-sealing ED

Series	D1	T1	D3	D4	L1	L2	L3	L4	S1	S2	Weight g/1 piece	Order code*	PN (bar) ¹⁾		
													CF	71	MS
LL ²⁾	04	G 1/8 A	3	14	20.0	9.5	6.5	19	14	10	10	GE04LLREDOMD	100	100	63
	06	G 1/8 A	4	14	20.0	8.0	6.5	20	14	12	11	GE06LLREDOMD	100	100	63
L ³⁾	06	G 1/8 A	4	14	23.5	8.5	8.0	23	14	14	13	GE06LREDOMD	500	315	200
	06	G 1/4 A	4	19	29.0	10.0	12.0	25	19	14	28	GE06LR1/4EDOMD	500	315	200
	06	G 3/8 A	4	22	30.5	11.5	12.0	26	22	14	44	GE06LR3/8EDOMD	420	315	200
	06	G 1/2 A	4	27	33.0	12.0	14.0	27	27	14	61	GE06LR1/2EDOMD	400	315	200
	08	G 1/4 A	6	19	29.0	10.0	12.0	25	19	17	27	GE08LREDOMD	500	315	200
	08	G 1/8 A	4	14	24.5	9.5	8.0	24	14	17	16	GE08LR1/8EDOMD	500	315	200
	08	G 3/8 A	6	22	30.5	11.5	12.0	26	22	17	45	GE08LR3/8EDOMD	420	315	200
	08	G 1/2 A	6	27	33.0	12.0	14.0	27	27	17	74	GE08LR1/2EDOMD	400	315	200
	10	G 1/4 A	6	19	30.0	11.0	12.0	26	19	19	29	GE10LREDOMD	500	315	200
	10	G 1/8 A	4	14	25.5	10.5	8.0	25	17	19	21	GE10LR1/8EDOMD	500	315	200
	10	G 3/8 A	8	22	31.5	12.5	12.0	27	22	19	43	GE10LR3/8EDOMD	420	315	200
	10	G 1/2 A	8	27	34.0	13.0	14.0	28	27	19	71	GE10LR1/2EDOMD	400	315	200
	12	G 3/8 A	9	22	31.5	12.5	12.0	27	22	22	41	GE12LREDOMD	420	315	200
	12	G 1/8 A	4	14	26.5	11.5	8.0	26	19	22	26	GE12LR1/8EDOMD	420	315	200
	12	G 1/4 A	6	19	31.0	12.0	12.0	27	19	22	31	GE12LR1/4EDOMD	400	315	200
	12	G 1/2 A	10	27	34.0	13.0	14.0	28	27	22	67	GE12LR1/2EDOMD	400	315	200
	12	G 3/4 A	10	32	37.0	14.0	16.0	29	32	22	118	GE12LR3/4EDOMD	250	160	100
	15	G 1/2 A	11	27	35.0	14.0	14.0	29	27	27	72	GE15LREDOMD	400	315	200
	15	G 3/8 A	9	22	32.5	13.5	12.0	29	24	27	54	GE15LR3/8EDOMD	400	315	200
	15	G 3/4 A	12	32	38.0	15.0	16.0	30	32	27	116	GE15LR3/4EDOMD	250	160	100
	18	G 1/2 A	14	27	36.0	14.5	14.0	31	27	32	71	GE18LREDOMD	400	315	200
	18	G 3/8 A	9	22	33.5	14.0	12.0	30	27	32	66	GE18LR3/8EDOMD	400	315	200
	18	G 3/4 A	15	32	38.0	14.5	16.0	31	32	32	110	GE18LR3/4EDOMD	250	160	100
	22	G 3/4 A	18	32	40.0	16.5	16.0	33	32	36	102	GE22LREDOMD	250	160	100
	22	G 1/2 A	14	27	38.0	16.5	14.0	33	32	36	91	GE22LR1/2EDOMD	250	160	100
	22	G 1 A	19	40	43.0	17.5	18.0	34	41	36	189	GE22LR1EDOMD	250	160	100
	28	G 1 A	23	40	43.0	17.5	18.0	34	41	41	170	GE28LREDOMD	250	160	100
	28	G 3/4 A	18	32	41.0	17.5	16.0	34	41	41	159	GE28LR3/4EDOMD	250	160	100
	28	G 1 1/4 A	24	50	46.0	18.5	20.0	35	50	41	316	GE28LR11/4EDOMD	250	160	100
	35	G 1 1/4 A	30	50	48.0	17.5	20.0	39	50	50	272	GE35LREDOMD	250	160	100
	35	G 1 A	23	40	46.0	17.5	18.0	39	46	50	226	GE35LR1EDOMD	250	160	100
	35	G 1 1/2 A	30	55	52.0	19.5	22.0	41	55	50	423	GE35LR11/2EDOMD	250	160	100
	42	G 1 1/2 A	36	55	52.0	19.0	22.0	42	55	60	343	GE42LREDOMD	250	160	100
	42	G 1 A	23	40	48.0	19.0	18.0	42	55	60	324	GE42LR1EDOMD	250	160	100
	42	G 1 1/4 A	30	50	50.0	19.0	20.0	42	55	60	348	GE42LR11/4EDOMD	250	160	100

¹⁾ Pressure shown = item deliverable

²⁾ LL = very light series; ³⁾ L = light series

$$\frac{\text{PN (bar)}}{10} = \text{PN (MPa)}$$

Delivery without nut and ring. Information on ordering complete fittings or alternative sealing materials see page I7.

*Please add the suffixes below according to the material/surface required.

Order code suffixes			
Material	Suffix surface and material	Example	Standard sealing material (no additional suffix needed)
Steel, zinc plated, Cr(VI)-free	CF	GE18LREDOMDCF	NBR
Stainless Steel	71	GE18LREDOMD71	VIT
Brass	MS	GE18LREDOMDMS	NBR

GE-R-ED Male stud connector

Male BSPP thread – ED-seal (ISO 1179) / EO 24° cone end

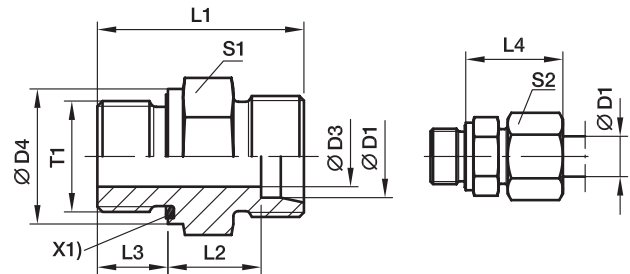

X1) Elastic-sealing ED

Series	D1	T1	D3	D4	L1	L2	L3	L4	S1	S2	Weight g/1 piece	Order code*	PN (bar) ¹⁾		
													CF	71	MS
S ⁴⁾	06	G 1/4 A	4	19	32.0	13.0	12	28	19	17	35	GE06SREDOMD	800	630	400
	06	G 1/8 A	4	14	27.5	12.5	8	27	14	17	21	GE06SR1/8EDOMD	500	315	
	06	G 3/8 A	4	22	34.5	15.5	12	30	22	17	52	GE06SR3/8EDOMD	630	630	
	06	G 1/2 A	4	27	39.0	18.0	14	33	27	17	83	GE06SR1/2EDOMD	630	400	
	08	G 1/4 A	5	19	34.0	15.0	12	30	19	19	41	GE08SREDOMD	800	630	400
	08	G 3/8 A	5	22	34.5	15.5	12	30	22	19	57	GE08SR3/8EDOMD	800	630	
	08	G 1/2 A	5	27	39.0	18.0	14	33	27	19	89	GE08SR1/2EDOMD	630	400	
	10	G 3/8 A	7	22	34.5	15.0	12	31	22	22	55	GE10SREDOMD	800	630	400
	10	G 1/4 A	5	19	34.0	14.5	12	31	19	22	42	GE10SR1/4EDOMD	800	630	
	10	G 1/2 A	7	27	39.0	17.5	14	34	27	22	97	GE10SR1/2EDOMD	630	630	
	12	G 3/8 A	8	22	36.5	17.0	12	33	22	24	62	GE12SREDOMD	630	630	400
	12	G 1/4 A	5	19	36.0	16.5	12	33	22	24	61	GE12SR1/4EDOMD	630	630	
12	G 1/2 A	8	27	39.0	17.5	14	34	27	24	99	GE12SR1/2EDOMD	630	630		
16	G 1/2 A	12	27	41.0	18.5	14	37	27	30	91	GE16SREDOMD	630	400	250	
16	G 3/8 A	8	22	38.5	18.0	12	36	27	30	83	GE16SR3/8EDOMD	630	400		
16	G 3/4 A	12	32	45.0	20.5	16	39	32	30	152	GE16SR3/4EDOMD	420	400		
20	G 3/4 A	16	32	47.0	20.5	16	42	32	36	149	GE20SREDOMD	420	400	250	
20	G 1/2 A	12	27	45.0	20.5	14	42	32	36	142	GE20SR1/2EDOMD	420	400		
20	G 1 A	16	40	51.0	22.5	18	44	41	36	265	GE20SR1EDOMD	420	400		
20	G 1 1/4 A	16	50	53.0	22.5	20	44	50	36	404	GE20SR11/4EDOMD	420	400		
25	G 1 A	20	40	53.0	23.0	18	47	41	46	266	GE25SREDOMD	420	400	250	
25	G 1/2 A	12	27	49.0	23.0	14	47	41	46	228	GE25SR1/2EDOMD	420	400		
25	G 3/4 A	16	32	51.0	23.0	16	47	41	46	255	GE25SR3/4EDOMD	420	400		
25	G 1 1/4 A	20	50	55.0	23.0	20	47	50	46	411	GE25SR11/4EDOMD	420	400		
25	G 1 1/2 A	20	55	60.0	26.0	22	50	55	46	549	GE25SR11/2EDOMD	315	315		
30	G 1 1/4 A	25	50	57.0	23.5	20	50	50	50	418	GE30SREDOMD	420	400	250	
30	G 1 A	20	40	55.0	23.5	18	50	46	50	344	GE30SR1EDOMD	420	400		
30	G 1 1/2 A	25	55	62.0	26.5	22	53	55	50	530	GE30SR11/2EDOMD	315	315		
38	G 1 1/2 A	32	55	64.0	26.0	22	57	55	60	563	GE38SREDOMD	420	315	200	
38	G 1 1/4 A	25	50	62.0	26.0	20	57	55	60	575	GE38SR11/4EDOMD	420	315		

1) Pressure shown = item deliverable

4) S = heavy series

$$\frac{\text{PN (bar)}}{10} = \text{PN (MPa)}$$

Delivery without nut and ring. Information on ordering complete fittings or alternative sealing materials see page 17.

*Please add the **suffixes** below according to the material/surface required

Order code suffixes			
Material	Suffix surface and material	Example	Standard sealing material (no additional suffix needed)
Steel, zinc plated, Cr(VI)-free	CF	GE16SREDOMDCF	NBR
Stainless Steel	71	GE16SREDOMD71	VIT
Brass	MS	GE16SREDOMDMS	NBR

GE-R Male stud connector

Male BSPP thread – metal sealing edge (ISO 1179) / EO 24° cone end

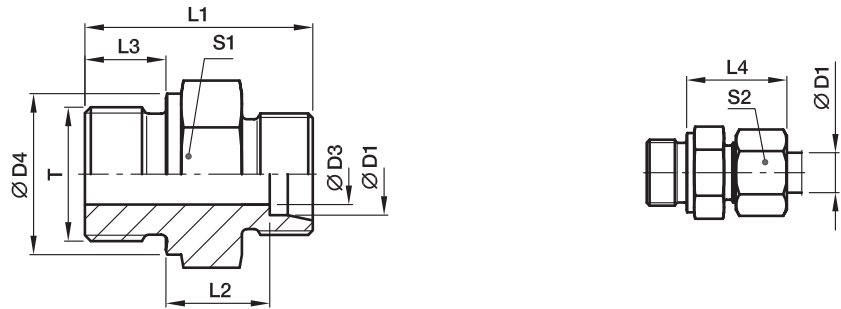

Series	D1	T	D3	D4	L1	L2	L3	L4	S1	S2	Weight g/1 piece	Order code*	PN (bar) ¹⁾		
													CF	71	MS
L ³⁾	06	G 1/8 A	4	14	23.5	8.5	8	23.0	14	14	14	GE06LR	315	315	200
	06	G 1/4 A	4	18	29.0	10.0	12	25.0	19	14	60	GE06LR1/4	315	315	200
	06	G 3/8 A	4	22	30.5	11.5	12	26.0	22	14	45	GE06LR3/8	315	315	200
	06	G 1/2 A	4	26	33.0	12.0	14	27.0	27	14	60	GE06LR1/2	315	315	
	08	G 1/4 A	6	18	29.0	10.0	12	25.0	19	17	26	GE08LR	315	315	200
	08	G 1/8 A	4	14	24.5	8.5	8	23.0	14	17	16	GE08LR1/8	315	315	
	08	G 3/8 A	6	22	30.5	11.5	12	26.0	22	17	44	GE08LR3/8	315	315	200
	08	G 1/2 A	6	26	33.0	12.0	14	27.0	27	17	74	GE08LR1/2	315	315	200
	10	G 1/4 A	6	18	30.0	11.0	12	26.0	19	19	31	GE10LR	315	315	200
	10	G 1/8 A	4	14	25.5	10.5	8	25.0	17	19	21	GE10LR1/8	315	315	
	10	G 3/8 A	8	22	31.5	12.5	12	27.0	22	19	44	GE10LR3/8	315	315	200
	10	G 1/2 A	8	26	34.0	13.0	14	28.0	27	19	72	GE10LR1/2	315	315	200
12	G 3/8 A	9	22	31.5	12.5	12	27.0	22	22	43	GE12LR	315	315	200	
12	G 1/8 A	4	14	26.5	11.5	8	26.0	19	22	27	GE12LR1/8	315	315		
12	G 1/4 A	6	18	31.0	12.0	12	27.0	19	22	32	GE12LR1/4	315	315	200	
12	G 1/2 A	10	26	34.0	13.0	14	28.0	27	22	67	GE12LR1/2	315	315	200	
12	G 3/4 A	10	32	37.0	14.0	16	29.0	32	22	120	GE12LR3/4	315	315		
15	G 1/2 A	11	26	35.0	14.0	14	29.0	27	27	72	GE15LR	250	250	160	
15	G 3/8 A	9	22	32.5	13.5	12	29.0	24	27	56	GE15LR3/8	250	250	160	
15	G 3/4 A	12	32	38.0	15.0	16	30.0	32	27	118	GE15LR3/4	250	250		
18	G 1/2 A	14	26	36.0	14.5	14	31.0	27	32	72	GE18LR	250	250	160	
18	G 3/8 A	9	22	33.5	14.0	12	29.5	27	32	69	GE18LR3/8	250	250		
18	G 3/4 A	15	32	38.0	14.5	16	30.0	32	32	112	GE18LR3/4	250	250		
22	G 3/4 A	18	32	40.0	16.5	16	33.0	32	36	103	GE22LR	160	160	100	
22	G 1/2 A	14	26	38.0	16.5	14	33.0	32	36	91	GE22LR1/2	160	160	100	
22	G 1 A	19	39	43.0	17.5	18	33.5	41	36	184	GE22LR1	160	160		
28	G 1 A	23	39	43.0	17.5	18	34.0	41	41	168	GE28LR	160	160	100	
28	G 1/2 A	14	26	39.0	17.5	14	34.0	41	41	141	GE28LR1/2	160	160		
28	G 3/4 A	18	32	41.0	17.5	16	34.0	41	41	156	GE28LR3/4	160	160		
28	G 1 1/4 A	24	50	46.0	18.3	20	35.0	50	41	314	GE28LR11/4	160	160		
35	G 1 1/4 A	30	49	48.0	17.5	20	39.0	50	50	276	GE35LR	160	160	100	
35	G 1/2 A	14	26	42.0	17.5	14	39.0	46	50	194	GE35LR1/2	160	160		
35	G 3/4 A	18	32	44.0	17.5	16	39.0	46	50	202	GE35LR3/4	160	160		
35	G 1 A	23	39	46.0	17.5	18	39.0	46	50	234	GE35LR1	160	160		
35	G 1 1/2 A	30	55	52.0	19.5	22	41.0	55	50	355	GE35LR11/2	160	160		
42	G 1 1/2 A	36	55	52.0	19.0	22	42.0	55	60	349	GE42LR	160	160	100	
42	G 1 A	23	39	48.0	19.0	18	42.0	55	60	327	GE42LR1	160	160		
42	G 1 1/4 A	30	49	50.0	19.0	20	42.0	55	60	336	GE42LR11/4	160	160		

¹⁾ Pressure shown = item deliverable

³⁾ L = light series

$\frac{\text{PN (bar)}}{10} = \text{PN (MPa)}$

Delivery without nut and ring. Information on ordering complete fittings see page I7.

*Please add the **suffixes** below according to the material/surface required.

Order code suffixes		
Material	Suffix surface and material	Example
Steel, zinc plated, Cr(VI)-free	CFX	GE18LR CFX
Stainless Steel	71X	GE18LR71X
Brass	MSX	GE18LRMSX

GE-R Male stud connector

Male BSPP thread – metal sealing edge (ISO 1179) / EO 24° cone end

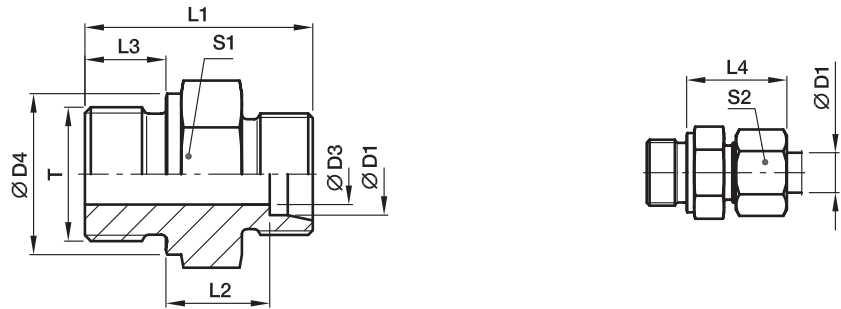

Series	D1	T	D3	D4	L1	L2	L3	L4	S1	S2	Weight g/1 piece	Order code*	PN (bar) ¹⁾		
													CF	71	MS
S ⁴⁾	06	G 1/4 A	4	18	32.0	13.0	12	28	19	17	35	GE06SR	400	400	250
	06	G 1/8 A	3	14	27.5	12.5	8	27	14	17	22	GE06SR1/8	400	400	
	06	G 3/8 A	4	22	34.5	15.5	12	30	22	17	57	GE06SR3/8	400	400	
	06	G 1/2 A	4	26	39.0	18.0	14	33	27	17	83	GE06SR1/2	400	400	
	08	G 1/4 A	5	18	34.0	15.0	12	30	19	19	41	GE08SR	400	400	250
	08	G 3/8 A	5	22	34.5	15.5	12	30	22	19	59	GE08SR3/8	400	400	
	08	G 1/2 A	5	26	39.0	18.0	14	33	27	19	100	GE08SR1/2	400	400	
	10	G 3/8 A	7	22	34.5	15.0	12	31	22	22	56	GE10SR	400	400	250
	10	G 1/4 A	5	18	34.0	14.5	12	31	19	22	43	GE10SR1/4	400	400	
	10	G 1/2 A	7	26	39.0	17.5	14	34	27	22	97	GE10SR1/2	400	400	
	12	G 3/8 A	8	22	36.5	17.0	12	33	22	24	62	GE12SR	400	400	250
	12	G 1/4 A	5	18	36.0	16.5	12	33	22	24	57	GE12SR1/4	400	400	
12	G 1/2 A	8	26	39.0	17.5	14	34	27	24	57	GE12SR1/2	400	400		
16	G 1/2 A	12	26	41.0	18.5	14	37	27	30	92	GE16SR	400	400	250	
16	G 3/8 A	8	22	38.5	18.0	12	36	27	30	83	GE16SR3/8	400	400		
16	G 3/4 A	12	32	45.0	20.5	16	39	32	30	157	GE16SR3/4	400	400		
20	G 3/4 A	16	32	47.0	20.5	16	42	32	36	151	GE20SR	400	400	250	
20	G 1/2 A	12	26	45.0	20.5	14	42	32	36	142	GE20SR1/2	400	400		
20	G 1 A	16	39	51.0	22.5	18	44	41	36	273	GE20SR1	250	250		
20	G 1 1/4 A	16	49	53.0	22.5	20	44	50	36	387	GE20SR11/4	160	160		
25	G 1 A	20	39	53.0	23.0	18	47	41	46	267	GE25SR	250	250	160	
25	G 3/4 A	16	32	51.0	23.0	16	47	41	46	245	GE25SR3/4	250	250		
25	G 1 1/4 A	20	49	55.0	23.0	20	47	50	46	422	GE25SR11/4	160	160		
30	G 1 1/4 A	25	49	57.0	23.5	20	50	50	50	422	GE30SR	160	160	100	
30	G 1 A	20	39	55.0	23.5	18	50	46	50	337	GE30SR1	160	160		
38	G 1 1/2 A	32	55	64.0	26.0	22	57	55	60	560	GE38SR	160	160	100	
38	G 1 1/4 A	25	49	62.0	26.0	20	57	55	60	578	GE38SR11/4	160	160		

1) Pressure shown = item deliverable

4) S = heavy series

$$\frac{\text{PN (bar)}}{10} = \text{PN (MPa)}$$

Delivery without nut and ring. Information on ordering complete fittings see page I7.

*Please add the **suffixes** below according to the material/surface required.

Order code suffixes		
Material	Suffix surface and material	Example
Steel, zinc plated, Cr(VI)-free	CFX	GE16SRCFX
Stainless Steel	71X	GE16SR71X
Brass	MSX	GE16SRMSX

GE-R(KEG) Male stud connector

Male short BSPT taper thread (DIN 3852-2, type C) / EO 24° cone end

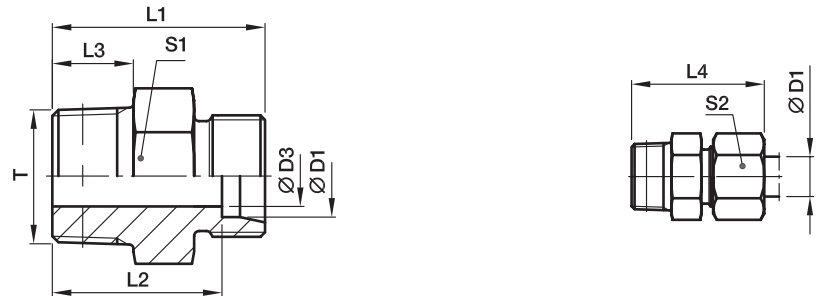

Series	D1	T	D3	L1	L2	L3	L4	S1	S2	Weight g/1 piece	Order code*	PN (bar) ¹⁾		
												CF	71	MS
LL ²⁾	04	R 1/8 tap.	3.0	20	16.0	8	26	11*	10	8	GE04LLR	100	100	63
	06	R 1/8 tap.	4.5	20	14.5	8	26	11*	12	8	GE06LLR	100	100	63
	08	R 1/8 tap.	6.0	22	16.5	8	28	12	14	10	GE08LLR	100	100	63
	08	R 1/4 tap.	6.0	26	20.5	12	32	14	14	18	GE08LLR1/4	100	100	63
	10	R 1/4 tap.	8.0	26	20.5	12	32	14	17	15	GE10LLR	100		63
	12	R 1/4 tap.	8.0	26	20.0	12	32	17	19	18	GE12LLR	100		63
	12	R 3/8 tap.	10.0	26	20.0	12	32	17	19	23	GE12LLR3/8	100		63
L ³⁾	06	R 1/8 tap.	4.0	22	15.0	8	30	12	14	11	GE06LR1/8KEG	315	315	
	06	R 1/4 tap.	4.0	27	20.0	12	35	17	14	24	GE06LR1/4KEG	315	315	200
	08	R 1/8 tap.	4.0	23	16.0	8	31	14	17	15	GE08LR1/8KEG	315	315	200
	08	R 1/4 tap.	6.0	27	20.0	12	35	17	17	22	GE08LR1/4KEG	315	315	
	10	R 1/4 tap.	7.0	28	21.0	12	36	17	19	24	GE10LR1/4KEG	315	315	
	12	R 1/4 tap.	7.0	29	22.0	12	37	19	22	53	GE12LR1/4KEG	315	315	200
	12	R 3/8 tap.	9.0	29	22.0	12	37	19	22	33	GE12LR3/8KEG	315	315	
	12	R 1/2 tap.	10.0	31	24.0	14	39	24	22	53	GE12LR1/2KEG	315	315	200
	15	R 3/8 tap.	9.0	30	23.0	12	38	24	27	49	GE15LR3/8KEG	315	315	200
	15	R 1/2 tap.	11.0	32	25.0	14	40	24	27	59	GE15LR1/2KEG	315	315	
	18	R 1/2 tap.	14.0	33	25.5	14	42	27	32	64	GE18LR1/2KEG	315	315	
	22	R 3/4 tap.	17.0	37	29.5	16	46	32	36	99	GE22LR3/4KEG	160	160	
	28	R 1 tap.	23.0	40	32.5	18	49	41	41	154	GE28LR1KEG	160	160	
	35	R 1 1/4 tap.	30.0	45	34.5	20	56	46	50	238	GE35LR11/4KEG	160	160	
42	R 1 1/2 tap.	36.0	49	38.0	22	61	55	60	335	GE42LR11/2KEG	160	160		

¹⁾ Pressure shown = item deliverable

²⁾ LL = very light series; ³⁾ L = light series

$\frac{PN \text{ (bar)}}{10} = PN \text{ (MPa)}$

Delivery without nut and ring. Information on ordering complete fittings see page I7.

^{*)} S1 = 12 for 1.4571

*Please add the **suffixes** below according to the material/surface required.

Order code suffixes		
Material	Suffix surface and material	Example
Steel, zinc plated, Cr(VI)-free	CFX	GE06LR1/4KEGCFX
Stainless Steel	71X	GE06LR1/4KEG71X
Brass	MSX	GE06LR1/4KEGMSX

GE-M Male stud connector

Male metric thread – metal sealing edge (ISO 9974) / EO 24° cone end

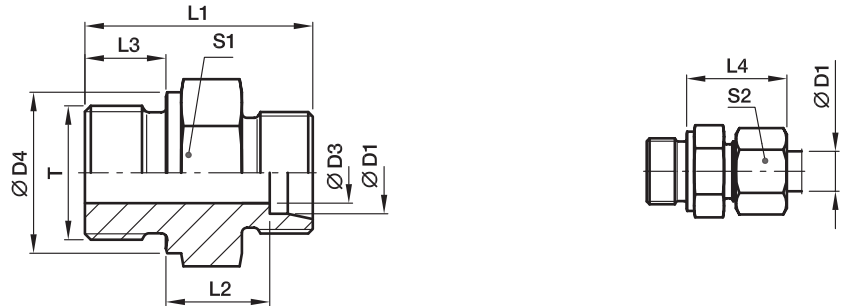

Series	D1	T	D3	D4	L1	L2	L3	L4	S1	S2	Weight g/1 piece	Order code*	PN (bar) ¹⁾		
													CF	71	MS
L ³⁾	06	M 10×1.0	4	14	23.5	8.5	8	23	14	14	13	GE06LM	315	315	200
	08	M 12×1.5	6	17	29.0	10.0	12	25	17	17	22	GE08LM	315	315	200
	10	M 14×1.5	7	19	30.0	11.0	12	26	19	19	31	GE10LM	315	315	200
	10	M 10×1.0	4	14	25.5	10.5	8	25	17	19	20	GE10LM10X1	315	315	
	10	M 12×1.5	6	17	30.0	11.0	12	26	17	19	25	GE10LM12X1.5	315	315	
	10	M 16×1.5	8	21	31.5	12.0	12	27	22	19	41	GE10LM16X1.5	315	315	
	10	M 18×1.5	8	23	31.5	12.5	12	27	24	19	50	GE10LM18X1.5	315	315	
	10	M 22×1.5	8	27	35.0	14.0	14	29	27	19	72	GE10LM22X1.5	315	315	
	12	M 14×1.5	7	19	30.0	11.0	12	26	19	22	30	GE12LM14X1.5	315	315	
	12	M 16×1.5	9	21	31.5	12.5	12	27	22	22	40	GE12LM	315	315	
	12	M 18×1.5	10	23	31.5	12.5	12	27	24	22	47	GE12LM18X1.5	315	315	
	12	M 22×1.5	10	27	35.0	14.0	14	29	27	22	76	GE12LM22X1.5	315	315	
	15	M 16×1.5	9	21	32.0	13.0	12	28	24	27	50	GE15LM16X1.5	250	250	
	15	M 18×1.5	11	23	32.5	13.5	12	29	24	27	52	GE15LM	250	250	160
	15	M 22×1.5	12	27	36.0	15.0	14	30	27	27	77	GE15LM22X1.5	250	250	
	18	M 18×1.5	11	23	33.5	14.0	12	30	27	32	68	GE18LM18X1.5	250	250	
	18	M 22×1.5	14	27	36.0	14.5	14	31	27	32	77	GE18LM	250	250	160
	22	M 22×1.5	14	27	38.0	16.5	14	33	32	36	92	GE22LM22X1.5	160	160	
	22	M 26×1.5	18	31	40.0	16.5	16	33	32	36	102	GE22LM	160	160	100
	28	M 33×2.0	23	39	43.0	17.5	18	34	41	41	168	GE28LM	160	160	100
35	M 42×2.0	30	49	48.0	17.5	20	39	50	50	280	GE35LM	160	160	100	
42	M 48×2.0	36	55	52.0	19.0	22	42	55	60	354	GE42LM	160	160	100	
S ⁴⁾	06	M 12×1.5	4	17	32.0	13.0	12	28	17	17	30	GE06SM	400	400	250
	06	M 14×1.5	4	19	34.0	15.0	12	30	19	17	42	GE06SM14X1.5	400	400	
	08	M 14×1.5	5	19	34.0	15.0	12	30	19	19	43	GE08SM	400	400	250
	10	M 16×1.5	7	21	34.5	15.0	12	31	22	22	54	GE10SM	400	400	250
	12	M 18×1.5	8	23	36.5	17.0	12	33	24	24	72	GE12SM	400	400	250
	12	M 14×1.5	5	19	36.0	16.5	12	33	22	24	60	GE12SM14X1.5	400	400	
	12	M 22×1.5	8	27	39.0	17.5	14	34	27	24	103	GE12SM22X1.5	400	400	
	16	M 18×1.5	8	23	38.5	18.0	12	36	27	30	88	GE16SM18X1.5	400	400	
	16	M 22×1.5	12	27	41.0	18.5	14	37	27	30	97	GE16SM	400	400	250
	20	M 27×2.0	16	32	47.0	20.5	16	42	32	36	155	GE20SM	400	400	250
	25	M 33×2.0	20	39	53.0	23.0	18	47	41	46	268	GE25SM	250	250	160
	30	M 42×2.0	25	49	57.0	23.5	20	50	50	50	421	GE30SM	160	160	100
	38	M 48×2.0	32	55	64.0	26.0	22	57	55	60	568	GE38SM	160	160	100

1) Pressure shown = item deliverable

3) L = light series; 4) S = heavy series

$$PN \text{ (bar)} = \frac{PN \text{ (MPa)}}{10}$$

Delivery without nut and ring. Information on ordering complete fittings see page I7.

*Please add the **suffixes** below according to the material/surface required.

Order code suffixes		
Material	Suffix surface and material	Example
Steel, zinc plated, Cr(VI)-free	CFX	GE16SMCFX
Stainless Steel	71X	GE16SM71X
Brass	MSX	GE16SMMSX

GE-M(KEG) Male stud connector

Male short metric taper thread (DIN 3852-1, type C) / EO 24° cone end

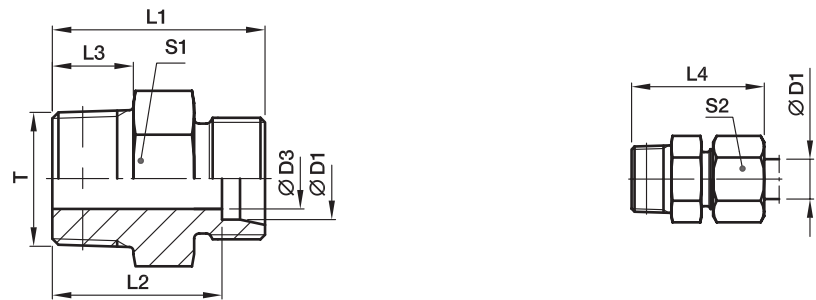

Series	D1	T	D3	L1	L2	L3	L4	S1	S2	Weight g/1 piece	Order code*	PN (bar) ¹⁾		
												CF	71	MS
LL ²⁾	04	M 06×1.0 tap.	2.0	20	16.0	8	26	9*	10	5	GE04LLM6X1KEG	100		
	04	M 08×1.0 tap.	3.0	20	16.0	8	26	10*	10	7	GE04LLM	100	100	63
	06	M 10×1.0 tap.	4.5	20	14.5	8	26	11*	12	9	GE06LLM	100	100	63
	06	M 08×1.0 tap.	3.5	20	14.5	8	26	11*	12	9	GE06LLM8X1KEG	100		
	08	M 10×1.0 tap.	6.0	22	16.5	8	28	12*	14	10	GE08LLM	100	100	63

¹⁾ Pressure shown = item deliverable

²⁾ LL = very light series

$$\frac{PN \text{ (bar)}}{10} = PN \text{ (MPa)}$$

Delivery without nut and ring. Information on ordering complete fittings see page 17.

*S1=SW12 in 1.4571

Order code suffixes		
Material	Suffix surface and material	Example
Steel, zinc plated, Cr(VI)-free	CFX	GE06LLMCFX
Stainless Steel	71X	GE06LLM71X
Brass	MSX	GE06LLMMSX

*Please add the **suffixes** below according to the material/surface required.

GE-UNF/UN Male stud connector

Male UNF/UN thread – O-ring (ISO 11926) / EO 24° cone end

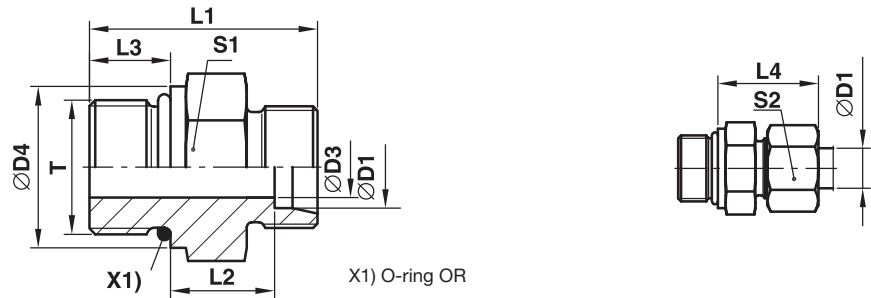

Series	D1	T	D3	D4	L1	L2	L3	L4	S1	S2	Weight g/1 piece	Order code*	PN (bar) ¹⁾	
													CF	71
L ³⁾	08	7/16-20UNF-2A	5.0	–	26	10.0	9.0	25	17	17	21	GE08L7/16UNFOMD	315	315
	10	7/16-20UNF-2A	5.0	–	27	11.0	9.0	26	17	19	23	GE10L7/16UNFOMD	315	315
	12	9/16-18UNF-2A	7.0	–	28	11.0	10.0	26	19	22	32	GE12L9/16UNFOMD	315	315
	12	3/4-16UNF-2A	10.0	–	31	13.0	11.0	28	24	22	52	GE12L3/4UNFOMD	315	315
	12	7/8-14UNF-2A	10.0	–	34	14.3	12.7	29	27	22	77	GE12L7/8UNFOMD	315	315
	15	3/4-16UNF-2A	11.0	–	32	14.0	11.0	29	24	27	57	GE15L3/4UNFOMD	315	315
	15	7/8-14UNF-2A	12.0	–	35	15.3	12.7	30	27	27	81	GE15L7/8UNFOMD	315	315
	18	3/4-16UNF-2A	11.0	23.9	33	14.5	11.0	31	27	32	68	GE18L3/4UNFOMD	315	315
	18	7/8-14UNF-2A	14.0	–	35	14.8	12.7	31	27	32	72	GE18L7/8UNFOMD	315	315
	22	7/8-14UNF-2A	14.0	26.9	37	16.8	12.7	33	32	36	94	GE22L7/8UNFOMD	160	160
	22	1 1/16-12UN-2A	18.0	–	39	16.5	15.0	33	32	36	103	GE22L11/16UNOMD	160	160
	22	1 5/16-12UN-2A	19.0	–	40	17.5	15.0	34	41	36	163	GE22L15/16UNOMD	160	160
	28	1 1/16-12UN-2A	18.0	33.3	40	17.5	15.0	34	41	41	152	GE28L11/16UNOMD	160	160
	28	1 5/16-12UN-2A	23.0	–	40	17.5	15.0	34	41	41	163	GE28L15/16UNOMD	160	160
	35	1 5/16-12UN-2A	23.0	39.6	43	17.5	15.0	39	46	50	222	GE35L15/16UNOMD	160	160
	35	1 5/8-12UN-2A	29.0	–	43	17.5	15.0	39	50	50	257	GE35L15/8UNOMD	160	160
42	1 5/8-12UN-2A	29.0	47.7	45	19.0	15.0	42	55	60	339	GE42L15/8UNOMD	160	160	
S ⁴⁾	08	7/16-20UNF-2A	4.0	–	31	13.0	11.0	30	17	19	33	GE08S7/16UNFOMD	630	630
	10	9/16-18UNF-2A	6.0	–	32	12.5	12.0	31	19	22	42	GE10S9/16UNFOMD	630	630
	12	9/16-18UNF-2A	6.0	19.0	32	12.5	12.0	31	22	24	50	GE12S9/16UNFOMD	630	630
	12	3/4-16UNF-2A	8.0	–	36	14.5	14.0	34	24	24	73	GE12S3/4UNFOMD	630	630
	16	3/4-16UNF-2A	10.0	–	35	12.5	14.0	34	24	30	90	GE16S3/4UNFOMD	400	400
	16	7/8-14UNF-2A	12.0	–	40	15.5	16.0	37	27	30	95	GE16S7/8UNFOMD	400	400
	20	3/4-16UNF-2A	10.0	23.9	42	17.5	14.0	42	32	36	132	GE20S3/4UNFOMD	400	400
	20	7/8-14UNF-2A	12.0	26.9	44	17.5	16.0	42	32	36	141	GE20S7/8UNFOMD	400	400
	20	1 1/16-12UN-2A	16.0	–	46	17.0	18.5	42	32	36	163	GE20S11/16UNOMD	400	400
	25	1 1/16-12UN-2A	16.0	33.3	50	19.5	18.5	47	36	46	206	GE25S11/16UNOMD	400	400
	25	1 5/16-12UN-2A	20.0	–	50	19.5	18.5	47	41	46	258	GE25S15/16UNOMD	400	400
	30	1 5/16-12UN-2A	20.0	39.6	52	20.0	18.5	50	46	50	327	GE30S15/16UNOMD	400	400
	30	1 5/8-12UN-2A	24.0	–	52	20.0	18.5	50	50	50	422	GE30S15/8UNOMD	400	400
	38	1 5/8-12UN-2A	24.0	47.7	57	22.5	18.5	57	55	60	554	GE38S15/8UNOMD	315	315

1) Pressure shown = item deliverable

3) L = light series; 4) S = heavy series

$$\frac{PN \text{ (bar)}}{10} = PN \text{ (MPa)}$$

Delivery without nut and ring. Information on ordering complete fittings or alternative sealing materials see page 17.

*Please add the suffixes below according to the material/surface required.

Order code suffixes			
Material	Suffix surface and material	Example	Standard sealing material (no additional suffix needed)
Steel, zinc plated, Cr(VI)-free	CF	GE16S3/4UNFOMDCF	NBR
Stainless Steel	71	GE16S3/4UNFOMD71	VIT

GE-NPT Male stud connector

Male NPT thread (SAE J476) / EO 24° cone end

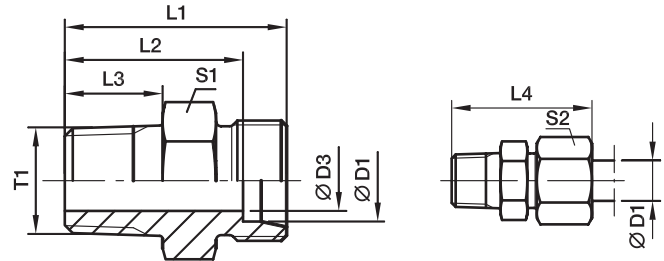

Series	D1	T1	D3	L1	L2	L3	L4	S1	S2	Weight g/1 piece	Order code*	PN (bar) ¹⁾		
												CF	71	MS
LL ²⁾	04	1/8-27 NPT	3.0	22.0	18.0	10.0	28	11*	10	9	GE04LL1/8NPT	100	100	
	06	1/8-27 NPT	4.5	22.0	16.5	10.0	28	11*	12	9	GE06LL1/8NPT	100	100	63
	08	1/8-27 NPT	5.0	24.0	18.5	10.0	30	12	14	11	GE08LL1/8NPT	100	100	63
L ³⁾	06	1/8-27 NPT	4.0	24.0	17.0	10.0	32	12	14	12	GE06L1/8NPT	315	315	200
	06	1/4-18 NPT	4.0	30.0	23.0	14.5	38	17	14	27	GE06L1/4NPT	315	315	200
	06	3/8-18 NPT	4.0	30.0	23.0	14.5	38	19	14	32	GE06L3/8NPT	315	315	
	06	1/2-14 NPT	4.0	36.0	29.0	19.5	44	22	14	53	GE06L1/2NPT	315	315	
	08	1/8-27 NPT	4.0	25.0	18.0	10.0	33	14	17	16	GE08L1/8NPT	315	315	
	08	1/4-18 NPT	6.0	30.0	23.0	14.5	38	17	17	25	GE08L1/4NPT	315	315	200
	08	3/8-18 NPT	6.0	30.0	23.0	14.5	38	19	17	34	GE08L3/8NPT	315	315	
	08	1/2-14 NPT	6.0	36.0	29.0	19.5	44	22	17	54	GE08L1/2NPT	315	315	
	10	1/8-27 NPT	4.0	25.0	18.0	10.0	33	17	19	19	GE10L1/8NPT	315	315	
	10	1/4-18 NPT	7.0	31.0	24.0	14.5	39	17	19	25	GE10L1/4NPT	315	315	200
	10	3/8-18 NPT	7.0	32.0	25.0	14.5	40	19	19	40	GE10L3/8NPT	315	315	
	10	1/2-14 NPT	8.0	37.0	30.0	19.5	45	22	19	54	GE10L1/2NPT	315	315	
	10	3/4-14 NPT	8.0	38.0	31.0	19.5	46	30	19	93	GE10L3/4NPT	315	315	
	12	1/8-27 NPT	4.0	26.0	19.0	10.0	34	19	22	52	GE12L1/8NPT	315	315	
	12	1/4-18 NPT	7.0	32.0	25.0	14.5	40	19	22	31	GE12L1/4NPT	315	315	200
	12	3/8-18 NPT	8.0	32.0	25.0	14.5	40	19	22	37	GE12L3/8NPT	315	315	200
	12	1/2-14 NPT	10.0	37.0	30.0	19.5	45	22	22	62	GE12L1/2NPT	315	315	200
	15	3/8-18 NPT	8.0	33.0	26.0	14.5	41	24	27	53	GE15L3/8NPT	315	315	
	15	1/2-14 NPT	12.0	38.0	31.0	19.5	46	24	27	63	GE15L1/2NPT	315	315	200
	15	3/4-14 NPT	12.0	39.0	32.0	19.5	47	30	27	112	GE15L3/4NPT	315	315	
	15	1-11.5 NPT	12.0	45.0	38.0	24.5	53	36	27	158	GE15L1NPT	315	315	
	18	3/8-18 NPT	8.0	34.0	26.5	14.5	43	27	32	69	GE18L3/8NPT	315	315	
	18	1/2-14 NPT	12.0	39.0	31.5	19.5	48	27	32	79	GE18L1/2NPT	315	315	200
	18	3/4-14 NPT	15.0	39.0	31.5	19.5	48	30	32	104	GE18L3/4NPT	315	315	
	18	1-11.5 NPT	15.0	45.0	37.5	24.5	54	36	32	159	GE18L1NPT	315	315	
	22	3/8-18 NPT	8.0	36.5	29.0	14.5	45	32	36	91	GE22L3/8NPT	160	160	
	22	1/2-14 NPT	12.0	41.0	33.5	19.5	50	32	36	96	GE22L1/2NPT	160	160	
	22	3/4-14 NPT	16.0	41.0	33.5	19.5	50	32	36	108	GE22L3/4NPT	160	160	100
	22	1-11.5 NPT	19.0	47.0	39.5	24.5	56	36	36	174	GE22L1NPT	160	160	
	28	3/4-14 NPT	16.0	42.0	34.5	19.5	51	41	41	157	GE28L3/4NPT	160	160	
	28	1-11.5 NPT	21.0	47.0	39.5	24.5	56	41	41	197	GE28L1NPT	160	160	100
	28	1 1/4-11.5 NPT	24.0	49.0	41.5	25.0	58	46	41	266	GE28L11/4NPT	160	160	
	35	1-11.5 NPT	22.0	50.0	39.5	24.5	61	46	50	280	GE35L1NPT	160	160	
	35	1 1/4-11.5 NPT	28.0	51.0	40.5	25.0	62	46	50	285	GE35L11/4NPT	160	160	
	42	1 1/4-11.5 NPT	28.0	53.0	42.0	25.0	65	55	60	382	GE42L11/4NPT	160	160	
	42	1 1/2-11.5 NPT	36.0	53.0	42.0	26.0	65	55	60	377	GE42L11/2NPT	160	160	

¹⁾ Pressure shown = item deliverable

²⁾ LL = very light series; ³⁾ L = light series

PN (bar)
10 = PN (MPa)

Delivery without nut and ring. Information on ordering complete fittings see page I7.

*S1=SW12 in 1.4571

*Please add the suffixes below according to the material/surface required.

Order code suffixes		
Material	Suffix surface and material	Example
Steel, zinc plated, Cr(VI)-free	CFX	GE18L1/2NPTCFX
Stainless Steel	71X	GE18L1/2NPT71X
Brass	MSX	GE18L1/2NPTMSX

GE-NPT Male stud connector

Male NPT thread (SAE J476) / EO 24° cone end

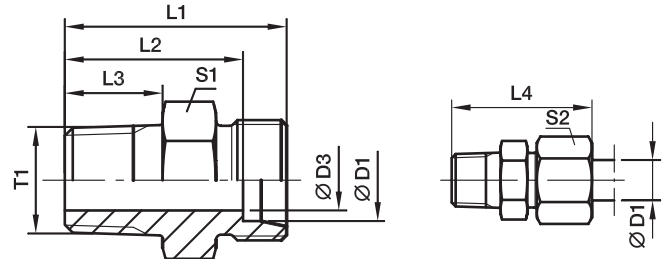

Series	D1	T1	D3	L1	L2	L3	L4	S1	S2	Weight g/1 piece	Order code*	PN (bar) ¹⁾			
												CF	71	MS	
S ⁴⁾	06	1/8-27 NPT	4	28	21.0	10.0	36	14	17	21	GE06S1/8NPT	630	630		
	06	1/4-18 NPT	4	35	28.0	14.5	43	17	17	37	GE06S1/4NPT	630	630	400	
	06	3/8-18 NPT	4	33	26.0	14.5	41	19	17	40	GE06S3/8NPT	630	630		
	06	1/2-14 NPT	4	42	35.0	19.5	50	22	17	71	GE06S1/2NPT	630	630		
	08	1/4-18 NPT	5	35	28.0	14.5	43	17	19	38	GE08S1/4NPT	630	630	400	
	08	3/8-18 NPT	5	35	28.0	14.5	43	19	19	46	GE08S3/8NPT	630	630		
	08	1/2-14 NPT	5	42	35.0	19.5	50	22	19	73	GE08S1/2NPT	630	630	400	
	10	1/4-18 NPT	5	35	27.5	14.5	44	19	22	45	GE10S1/4NPT	630	630		
	10	3/8-18 NPT	7	35	27.5	14.5	44	19	22	49	GE10S3/8NPT	630	630	400	
	10	1/2-14 NPT	7	42	34.5	19.5	51	22	22	73	GE10S1/2NPT	630	630	400	
	10	3/4-14 NPT	7	44	36.5	19.5	53	30	22	125	GE10S3/4NPT	630	630		
	12	1/4-18 NPT	5	37	29.5	14.5	46	22	24	57	GE12S1/4NPT	630	630		
	12	3/8-18 NPT	8	37	29.5	14.5	46	22	24	62	GE12S3/8NPT	630	630	400	
	12	1/2-14 NPT	8	42	34.5	19.5	51	22	24	83	GE12S1/2NPT	630	630	400	
	12	3/4-14 NPT	8	44	36.5	19.5	53	30	24	126	GE12S3/4NPT	630	630		
		16	3/8-18 NPT	8	39	30.5	14.5	49	27	30	84	GE16S3/8NPT	400	400	
		16	1/2-14 NPT	12	44	39.5	19.5	58	27	30	97	GE16S1/2NPT	400	400	250
		16	3/4-14 NPT	12	46	37.5	19.5	56	30	30	130	GE16S3/4NPT	400	400	
16		1-11.5 NPT	12	51	42.5	24.5	61	36	30	178	GE16S1NPT	400	400		
20		1/2-14 NPT	12	48	37.5	19.5	59	32	36	144	GE20S1/2NPT	400	400		
20		3/4-14 NPT	16	48	37.5	19.5	59	32	36	149	GE20S3/4NPT	400	400	250	
20		1-11.5 NPT	16	55	44.5	24.5	66	36	36	243	GE20S1NPT	400	400		
25		3/4-14 NPT	16	52	40.0	19.5	64	41	46	240	GE25S3/4NPT	400	400		
25		1-11.5 NPT	20	57	45.0	24.5	69	41	46	278	GE25S1NPT	400	400		
25		1 1/4-11.5 NPT	20	58	46.0	25.0	70	46	46	396	GE25S11/4NPT	400	400		
25		1 1/2-11.5 NPT	20	61	49.0	26.0	73	50	46	469	GE25S11/2NPT	400	400		
30		3/4-14 NPT	16	54	40.5	19.5	67	46	50	307	GE30S3/4NPT	400	400		
30		1-11.5 NPT	20	59	45.5	24.5	72	46	50	343	GE30S1NPT	400	400	100	
30		1 1/4-11.5 NPT	25	60	46.5	25.0	73	46	50	397	GE30S11/4NPT	400	400		
30		1 1/2-11.5 NPT	25	60	46.5	26.0	73	50	50	440	GE30S11/2NPT	400	400		
38		1-11.5 NPT	22	64	48.0	24.5	79	55	60	510	GE38S1NPT	315	315		
38		1 1/4-11.5 NPT	25	65	49.0	25.0	80	55	60	535	GE38S11/4NPT	315	315		
38		1 1/2-11.5 NPT	32	65	49.0	26.0	80	55	60	571	GE38S11/2NPT	315	315		

¹⁾ Pressure shown = item deliverable

⁴⁾ S = heavy series

$$\frac{\text{PN (bar)}}{10} = \text{PN (MPa)}$$

Delivery without nut and ring. Information on ordering complete fittings see page 17.

*Please add the **suffixes** below according to the material/surface required.

Order code suffixes		
Material	Suffix surface and material	Example
Steel, zinc plated, Cr(VI)-free	CFX	GE16S1/2NPTCFX
Stainless Steel	71X	GE16S1/2NPT71X
Brass	MSX	GE16S1/2NPTMSX

EGEO Swivel connector

Male metric thread – O-ring (ISO 6149) / EO 24° DKO swivel

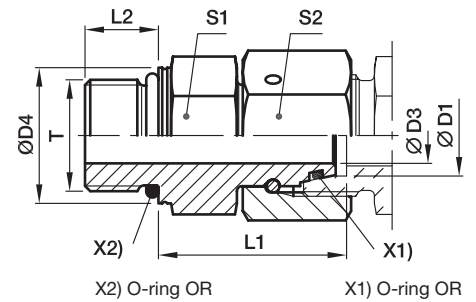

Series	D1	T	D3	D4	L1	L2	S1	S2	Weight g/1 piece	Order code*	PN (bar) ¹⁾ CF
L ³⁾	06	M 10×1.0	2.5	13.8	24.5	8.5	14	14	29	EGEO06LM	500
	08	M 12×1.5	4.0	16.8	26.5	11.0	17	17	43	EGEO08LM	500
	10	M 14×1.5	6.0	18.8	27.5	11.0	19	19	57	EGEO10LM	500
	12	M 16×1.5	8.0	21.8	30.5	11.5	22	22	85	EGEO12LM	400
	15	M 18×1.5	10.0	23.8	31.5	12.5	24	27	115	EGEO15LM	400
	18	M 22×1.5	13.0	26.8	31.5	13.0	27	32	152	EGEO18LM	400
	22	M 27×2.0	17.0	31.8	32.5	16.0	32	36	207	EGEO22LM27X2	250
	28	M 33×2.0	22.0	40.8	35.0	16.0	41	41	294	EGEO28LM	250
	35	M 42×2.0	28.0	49.8	42.5	16.0	50	50	516	EGEO35LM	250
	42	M 48×2.0	34.0	54.8	46.5	17.5	55	60	718	EGEO42LM	250
S ⁴⁾	06	M 12×1.5	2.5	16.8	27.0	11.0	17	17	49	EGEO06SM	800
	08	M 14×1.5	4.0	18.8	29.5	11.0	19	19	69	EGEO08SM	800
	10	M 16×1.5	6.0	21.8	32.0	12.5	22	22	96	EGEO10SM	800
	12	M 18×1.5	8.0	23.8	34.0	14.0	24	24	116	EGEO12SM	630
	16	M 22×1.5	11.0	26.8	37.0	15.0	27	30	179	EGEO16SM	630
	20	M 27×2.0	14.0	31.8	43.0	18.5	32	36	280	EGEO20SM	420
	25	M 33×2.0	18.0	40.8	48.0	18.5	41	46	502	EGEO25SM	420
	30	M 42×2.0	23.0	49.8	51.0	19.0	50	50	697	EGEO30SM	420
	38	M 48×2.0	30.0	54.8	60.0	21.5	55	60	965	EGEO38SM	420

1) Pressure shown = item deliverable

3) L = light series; 4) S = heavy series

$$\frac{\text{PN (bar)}}{10} = \text{PN (MPa)}$$

Information on ordering alternative sealing materials see page 17.

*Please add the **suffixes** below according to the material/surface required.

Order code suffixes			
Material	Suffix surface and material	Example	Standard sealing material (no additional suffix needed)
Steel, zinc plated, Cr(VI)-free	CF	EGEO16SMCF	NBR

EGE-M-ED Swivel connector

Male metric thread – ED-seal (ISO 9974) / EO 24° DKO swivel

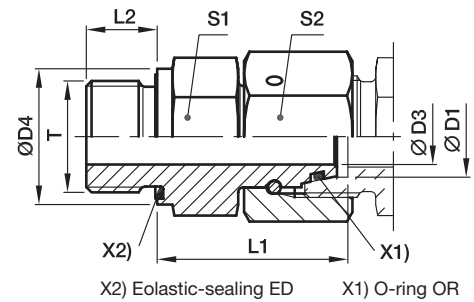

Series	D1 	T	D3	D4	L1	L2	S1	S2	Weight g/1 piece	Order code*	PN (bar) ¹⁾	
											CF	71
L ³⁾	06	M 10×1.0	2.5	14	24.5	8	14	14	27	EGE06LMED	500	315
	08	M 12×1.5	4.0	17	26.5	12	17	17	45	EGE08LMED	500	315
	10	M 14×1.5	6.0	19	27.5	12	19	19	57	EGE10LMED	500	315
	12	M 16×1.5	8.0	22	30.5	12	22	22	82	EGE12LMED	400	315
	12	M 22×1.5	8.0	27	27.0	14	27	22	92	EGE12LM22X1.5ED	400	315
	15	M 18×1.5	10.0	24	31.5	12	24	27	113	EGE15LMED	400	315
	15	M 22×1.5	10.0	27	32.0	14	27	27	142	EGE15LM22X1.5ED	400	315
	18	M 22×1.5	13.0	27	31.5	14	27	32	148	EGE18LMED	400	315
	22	M 26×1.5	17.0	32	32.5	16	32	36	203	EGE22LMED	250	160
	28	M 33×2.0	22.0	40	35.0	18	41	41	289	EGE28LMED	250	160
S ⁴⁾	35	M 42×2.0	28.0	50	42.5	20	50	50	511	EGE35LMED	250	160
	42	M 48×2.0	34.0	55	46.5	22	55	60	711	EGE42LMED	250	160
	06	M 12×1.5	2.5	17	27.0	12	17	17	47	EGE06SMED	800	630
	08	M 14×1.5	4.0	19	29.5	12	19	19	65	EGE08SMED	800	630
	10	M 16×1.5	6.0	22	32.0	12	22	22	91	EGE10SMED	800	630
	12	M 18×1.5	8.0	24	34.0	12	24	24	112	EGE12SMED	630	630
	16	M 22×1.5	11.0	27	37.0	14	27	30	174	EGE16SMED	630	400
	20	M 27×2.0	14.0	32	43.0	16	32	36	274	EGE20SMED	420	400
	25	M 33×2.0	18.0	40	48.0	18	41	46	497	EGE25SMED	420	400
	30	M 42×2.0	23.0	50	51.0	20	50	50	691	EGE30SMED	420	400
38	M 48×2.0	30.0	55	60.0	22	55	60	957	EGE38SMED	420	315	

¹⁾ Pressure shown = item deliverable

³⁾ L = light series; ⁴⁾ S = heavy series

$$\frac{\text{PN (bar)}}{10} = \text{PN (MPa)}$$

Information on ordering alternative sealing materials see page 17.

*Please add the **suffixes** below according to the material/surface required

Order code suffixes			
Material	Suffix surface and material	Example	Standard sealing material (no additional suffix needed)
Steel, zinc plated, Cr(VI)-free	CF	EGE16SMEDCF	NBR
Stainless Steel	71	EGE16SMED71	VIT

EGE-R-ED Swivel connector

Male BSPP thread – ED-seal (ISO 1179) / EO 24° DKO swivel

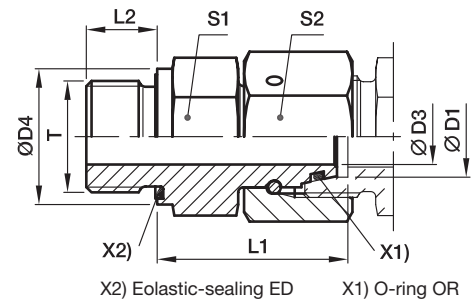

Series	D1 	T	D3	D4	L1	L2	S1	S2	Weight g/1 piece	Order code*	PN (bar) ¹⁾		
											CF	71	
L ³⁾	06	G 1/8 A	2.5	14	24.5	8	14	14	27	EGE06LRED	500	315	
	08	G 1/4 A	4.0	19	29.5	12	19	17	28	EGE08LRED	500	315	
	10	G 1/4 A	6.0	19	27.5	12	19	19	54	EGE10LRED	500	315	
	10	G 3/8 A	6.0	22	29.0	12	22	19	70	EGE10LR3/8ED	400	315	
	12	G 3/8 A	8.0	22	34.0	12	22	22	95	EGE12LRED	400	315	
	12	G 1/4 A	6.0	19	27.5	12	19	22	65	EGE12LR1/4ED	400	315	
	12	G 1/2 A	8.0	27	29.5	14	27	22	114	EGE12LR1/2ED	400	315	
	15	G 1/2 A	10.0	27	32.0	14	27	27	137	EGE15LRED	400	315	
	18	G 1/2 A	13.0	27	31.5	14	27	32	143	EGE18LRED	400	315	
	18	G 3/4 A	13.0	32	29.5	16	32	32	182	EGE18LR3/4ED	250	160	
	22	G 3/4 A	17.0	32	32.5	16	32	36	200	EGE22LRED	250	160	
	28	G 1 A	22.0	40	35.0	18	41	41	289	EGE28LRED	250	160	
	35	G 1 1/4 A	28.0	50	42.5	20	50	50	500	EGE35LRED	250	160	
	42	G 1 1/2 A	34.0	55	46.5	22	55	60	718	EGE42LRED	250	160	
	S ⁴⁾	06	G 1/4 A	2.5	19	27.0	12	19	17	53	EGE06SRED	800	630
		08	G 1/4 A	4.0	19	29.5	12	19	19	64	EGE08SRED	800	630
		10	G 3/8 A	6.0	22	32.0	12	22	22	93	EGE10SRED	800	630
		12	G 3/8 A	8.0	22	34.0	12	22	24	100	EGE12SRED	630	630
12		G 1/4 A	5.0	19	31.5	12	19	24	140	EGE12SR1/4ED	630	630	
12		G 1/2 A	8.0	27	35.0	14	27	24	140	EGE12SR1/2ED	630	630	
16		G 1/2 A	11.0	27	37.0	14	27	30	170	EGE16SRED	630	400	
20		G 3/4 A	14.0	32	43.0	16	32	36	273	EGE20SRED	420	400	
25		G 1 A	18.0	40	48.0	18	41	46	493	EGE25SRED	420	400	
30		G 1 1/4 A	23.0	50	51.0	20	50	50	691	EGE30SRED	420	400	
38		G 1 1/2 A	30.0	55	60.0	22	55	60	934	EGE38SRED	420	315	

¹⁾ Pressure shown = item deliverable

³⁾ L = light series; ⁴⁾ S = heavy series

$$\frac{\text{PN (bar)}}{10} = \text{PN (MPa)}$$

Information on ordering alternative sealing materials see page 17.

*Please add the **suffixes** below according to the material/surface required.

Order code suffixes			
Material	Suffix surface and material	Example	Standard sealing material (no additional suffix needed)
Steel, zinc plated, Cr(VI)-free	CF	EGE16SREDCF	NBR
Stainless Steel	71	EGE16SRED71	VIT

EVGE-M-ED Standpipe connector

Male metric thread – ED (ISO 9974) / EO standpipe adjustable

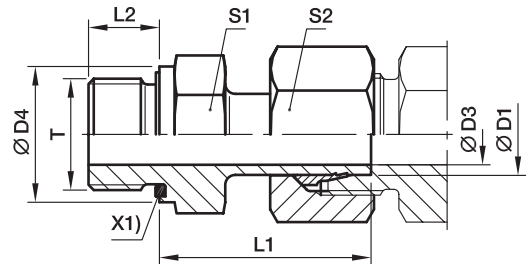

Pre-assembled nut and ring.
Final assembly (in appropriate body) at least 1/4 turn beyond the point of clearly perceptible resistance.

X1) Eolastic-sealing ED

Series	D1	T	D3	D4	L1	L2	S1	S2	Weight g/1 piece	Order code*	PN (bar) ¹⁾	
											CF	71
L ³⁾	06	M 10×1.0	3.5	14	24.5	8	14	14	24	EVGE06LMED	315	315
	08	M 12×1.5	5.5	17	26.5	12	17	17	38	EVGE08LMED	315	315
	10	M 14×1.5	7.0	19	27.5	12	19	19	49	EVGE10LMED	315	315
	12	M 16×1.5	9.0	22	30.0	12	22	22	67	EVGE12LMED	315	315
	15	M 18×1.5	11.0	24	30.5	12	24	27	95	EVGE15LMED	315	315
	18	M 22×1.5	14.0	27	31.5	14	27	32	137	EVGE18LMED	315	315
	22	M 26×1.5	18.0	32	32.5	16	32	36	183	EVGE22LMED	160	160
	28	M 33×2.0	23.0	40	35.0	18	41	41	264	EVGE28LMED	160	160
	35	M 42×2.0	29.5	50	42.5	20	50	50	444	EVGE35LMED	160	160
	42	M 48×2.0	35.5	55	46.5	22	55	60	614	EVGE42LMED	160	160
S ⁴⁾	06	M 12×1.5	3.5	17	27.0	12	17	17	43	EVGE06SMED	630	630
	08	M 14×1.5	4.5	19	29.5	12	19	19	59	EVGE08SMED	630	630
	10	M 16×1.5	6.5	22	32.0	12	22	22	82	EVGE10SMED	630	630
	12	M 18×1.5	7.5	24	34.0	12	24	24	104	EVGE12SMED	630	630
	16	M 22×1.5	11.5	27	37.0	14	27	30	162	EVGE16SMED	400	400
	20	M 27×2.0	15.5	32	43.0	16	32	36	254	EVGE20SMED	400	400
	25	M 33×2.0	18.0	40	48.0	18	41	46	493	EVGE25SMED	400	400
	30	M 42×2.0	23.5	50	51.0	20	50	50	654	EVGE30SMED	400	400
	38	M 48×2.0	29.0	55	60.0	22	55	60	962	EVGE38SMED	315	315

1) Pressure shown = item deliverable

3) L = light series; 4) S = heavy series

$$\frac{PN(\text{bar})}{10} = PN(\text{MPa})$$

The use of the swivel nut fitting EGE is to be preferred (see page I60).

Information on ordering alternative sealing materials see page 17.

*Please add the **suffixes** below according to the material/surface required.

Order code suffixes			
Material	Suffix surface and material	Example	Standard sealing material (no additional suffix needed)
Steel, zinc plated, Cr(VI)-free	CF	EVGE16SMEDCF	NBR
Stainless Steel	71	EVGE16SMED71	VIT

EVGE-R-ED Standpipe connector

Male BSPP thread – ED-seal (ISO 1179) / EO standpipe adjustable

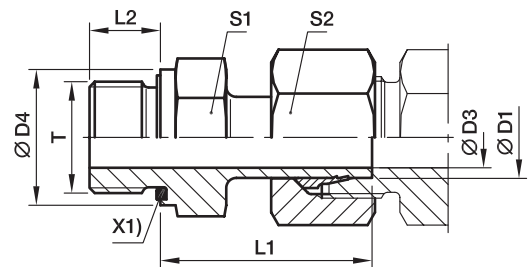

X1) Eolastic-sealing ED

Pre-assembled nut and ring.
Final assembly (in appropriate body) at least 1/4 turn beyond the point of clearly perceptible resistance.

Series	D1	T	D3	D4	L1	L2	S1	S2	Weight g/1 piece	Order code*	PN (bar) ¹⁾		
											CF	71	MS
L ³⁾	06	G 1/8 A	3.5	14	24.5	8	14	14	24	EVGE06LRED	315	315	200
	08	G 1/4 A	4.5	19	29.5	12	19	17	52	EVGE08LRED	315	315	200
	10	G 1/4 A	7.0	19	27.5	12	19	19	47	EVGE10LRED	315	315	200
	12	G 3/8 A	7.5	22	34.0	12	22	22	87	EVGE12LRED	315	315	200
	12	G 1/4 A	7.0	19	28.5	12	19	22	61	EVGE12LR1/4ED	315		
	12	G 1/2 A	7.5	27	34.5	14	27	22	121	EVGE12LR1/2ED	315	315	
	15	G 1/2 A	11.0	27	31.0	14	27	27	114	EVGE15LRED	315	315	200
	18	G 1/2 A	14.0	27	31.5	14	27	32	132	EVGE18LRED	315	315	200
	22	G 3/4 A	18.0	32	32.5	16	32	36	183	EVGE22LRED	160	160	100
	28	G 1 A	23.0	40	35.0	18	41	41	262	EVGE28LRED	160	160	
S ⁴⁾	35	G 1 1/4 A	29.5	50	42.5	20	50	50	436	EVGE35LRED	160	160	
	42	G 1 1/2 A	35.5	55	46.5	22	55	60	615	EVGE42LRED	160	160	
	06	G 1/4 A	3.5	19	27.0	12	19	17	48	EVGE06SRED	630	630	
	08	G 1/4 A	4.5	19	29.5	12	19	19	57	EVGE08SRED	630	630	
	10	G 3/8 A	6.5	22	32.0	12	22	22	84	EVGE10SRED	630	630	
	12	G 3/8 A	7.5	22	34.0	12	22	24	95	EVGE12SRED	630	630	
	12	G 1/2 A	7.5	27	34.5	14	27	24	130	EVGE12SR1/2ED	630	630	
	16	G 1/2 A	11.5	27	37.0	14	27	30	158	EVGE16SRED	400	400	
	16	G 3/4 A	11.5	32	39.0	16	32	30	222	EVGE16SR3/4ED	400		
	20	G 3/4 A	15.5	32	43.0	16	32	36	254	EVGE20SRED	400	400	
25	G 1 A	18.0	40	48.0	18	41	46	485	EVGE25SRED	400	400		
30	G 1 1/4 A	23.5	50	51.0	20	50	50	661	EVGE30SRED	400	400		
38	G 1 1/2 A	29.0	55	60.0	22	55	60	962	EVGE38SRED	315	315		

¹⁾ Pressure shown = item deliverable

³⁾ L = light series; ⁴⁾ S = heavy series

$$\frac{\text{PN (bar)}}{10} = \text{PN (MPa)}$$

The use of the swivel nut fitting EGE is to be preferred (see page I61).

Information on ordering alternative sealing materials see page I7.

Order code suffixes			
Material	Suffix surface and material	Example	Standard sealing material (no additional suffix needed)
Steel, zinc plated, Cr(VI)-free	CF	EVGE16SREDCF	NBR
Stainless Steel	71	EVGE16SRED71	VIT
Brass	MS	EVGE16SREDMS	NBR

*Please add the **suffixes** below according to the material/surface required.

EGE-NPT Swivel connector

Male NPT thread (SAE J476) / EO 24° DKO swivel

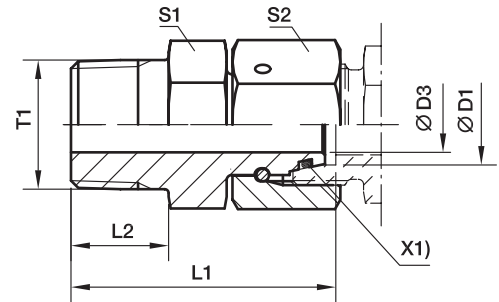

X1) O-ring OR

Series	D1 	T1	D3	L1	L2	S1	S2	Weight g/1 piece	Order code*	PN (bar) ¹⁾ CF
L ³⁾	06	1/8-27 NPT	2.5	31.5	10.0	11	14	23	EGE06L1/8NPT	315
	08	1/4-18 NPT	4.0	37.5	14.5	14	17	41	EGE08L1/4NPT	315
	10	1/4-18 NPT	6.0	38.0	14.5	14	19	44	EGE10L1/4NPT	315
	12	3/8-18 NPT	8.0	40.0	14.5	19	22	69	EGE12L3/8NPT	315
	15	1/2-14 NPT	10.0	49.5	19.5	22	27	127	EGE15L1/2NPT	315
	18	1/2-14 NPT	12.0	49.0	19.5	24	32	142	EGE18L1/2NPT	315
	22	3/4-14 NPT	16.0	52.0	19.5	27	36	200	EGE22L3/4NPT	160
	28	1-11.5 NPT	22.0	61.0	24.5	36	41	306	EGE28L1NPT	160
	35	1 1/4-11.5 NPT	28.0	65.5	25.0	46	50	486	EGE35L11/4NPT	160
	42	1 1/2-11.5 NPT	34.0	68.5	26.0	50	60	662	EGE42L11/2NPT	160
S ⁴⁾	06	1/4-18 NPT	2.5	37.5	14.5	14	17	42	EGE06S1/4NPT	630
	08	1/4-18 NPT	4.0	38.0	14.5	14	19	47	EGE08S1/4NPT	630
	10	3/8-18 NPT	6.0	40.5	14.5	19	22	75	EGE10S3/8NPT	630
	12	3/8-18 NPT	8.0	42.0	14.5	19	24	81	EGE12S3/8NPT	630
	16	1/2-14 NPT	11.0	51.0	19.5	22	30	145	EGE16S1/2NPT	400
	20	3/4-14 NPT	14.0	54.0	19.5	27	36	221	EGE20S3/4NPT	400
	25	1-11.5 NPT	18.0	63.5	24.5	36	46	422	EGE25S1NPT	400
	30	1 1/4-11.5 NPT	23.0	70.5	25.0	46	50	628	EGE30S11/4NPT	400
	38	1 1/2-11.5 NPT	30.0	73.5	26.0	50	60	770	EGE38S11/2NPT	315

1) Pressure shown = item deliverable

3) L = light series; 4) S = heavy series

$$\frac{PN(\text{bar})}{10} = PN(\text{MPa})$$

Information on ordering alternative sealing materials see page 17.

*Please add the **suffixes** below according to the material/surface required.

Order code suffixes			
Material	Suffix surface and material	Example	Standard sealing material (no additional suffix needed)
Steel, zinc plated, Cr(VI)-free	CF	EGE16S1/2NPTCF	NBR

EW-M-ED Assembled adjustable swivel elbow

EO 24° cone end / Male metric thread – ED-seal (ISO 9974)

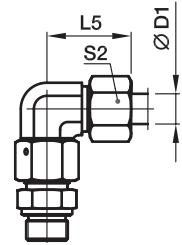
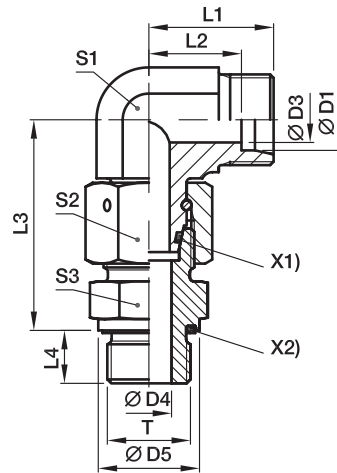

X1) O-ring OR
X2) Eolastic-sealing ED

Series	D1	T	D3	D4	D5	L1	L2	L3	L4	L5	S1	S2	S3	Weight g/1 piece	Order code*	PN (bar) ¹⁾	
																CF	71
L ³⁾	06	M 10×1.0	4	4	14	19	12.0	34.5	8	27	12	14	14	47	EW06LMEDOMD	500	315
	08	M 12×1.5	6	6	17	21	14.0	37.5	12	29	12	17	17	69	EW08LMEDOMD	500	315
	10	M 14×1.5	8	7	19	22	15.0	40.0	12	30	14	19	19	87	EW10LMEDOMD	500	315
	12	M 16×1.5	10	9	22	24	17.0	42.0	12	32	17	22	22	111	EW12LMEDOMD	400	315
	15	M 18×1.5	12	11	24	28	21.0	46.0	12	36	19	27	24	179	EW15LMEDOMD	400	315
	18	M 22×1.5	15	14	27	31	23.5	50.0	14	40	24	32	27	272	EW18LMEDOMD	400	315
	22	M 26×1.5	19	18	32	35	27.5	55.0	16	44	27	36	32	360	EW22LMEDOMD	250	160
	28	M 33×2.0	24	23	40	38	30.5	59.0	18	47	36	41	41	538	EW28LMEDOMD	250	160
	35	M 42×2.0	30	30	50	45	34.5	68.5	20	56	41	50	50	843	EW35LMEDOMD	250	160
	42	M 48×2.0	36	36	55	51	40.0	75.0	22	63	50	60	55	1353	EW42LMEDOMD	250	160
S ⁴⁾	06	M 12×1.5	4	4	17	23	16.0	40.0	12	31	12	17	17	77	EW06SMEDOMD	800	630
	08	M 14×1.5	5	5	19	24	17.0	42.5	12	32	14	19	19	107	EW08SMEDOMD	800	630
	10	M 16×1.5	6	7	22	25	17.5	45.0	12	34	17	22	22	146	EW10SMEDOMD	800	630
	12	M 18×1.5	8	8	24	29	21.5	48.0	12	38	17	24	24	178	EW12SMEDOMD	630	630
	16	M 22×1.5	12	12	27	33	24.5	55.0	14	43	24	30	27	307	EW16SMEDOMD	630	400
	20	M 27×2.0	16	16	32	37	26.5	65.0	16	48	27	36	32	459	EW20SMEDOMD	420	400
	25	M 33×2.0	20	20	40	42	30.0	73.0	18	54	36	46	41	812	EW25SMEDOMD	420	400
	30	M 42×2.0	25	25	50	49	35.5	78.5	20	62	41	50	50	1167	EW30SMEDOMD	420	400
	38	M 48×2.0	32	32	55	57	41.0	89.0	22	72	50	60	55	1790	EW38SMEDOMD	420	315

¹⁾ Pressure shown = item deliverable

³⁾ L = light series; ⁴⁾ S = heavy series

$\frac{PN(\text{bar})}{10} = PN(\text{MPa})$

Delivery without nut and ring. Information on ordering complete fittings or alternative sealing materials see page 17.

*Please add the **suffixes** below according to the material/surface required.

Order code suffixes			
Material	Suffix surface and material	Example	Standard sealing material (no additional suffix needed)
Steel, zinc plated, Cr(VI)-free	CF	EW16SMEDOMDCF	NBR
Stainless Steel	71	EW16SMEDOMD71	VIT

EW-R-ED Assembled adjustable swivel elbow

EO 24° cone end / Male BSPP thread – ED-seal (ISO 1179)

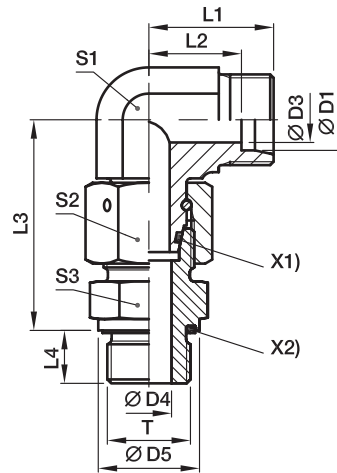

X1) O-ring OR
X2) Eolastic-sealing ED

Series	D1	T	D3	D4	D5	L1	L2	L3	L4	L5	S1	S2	S3	Weight g/1 piece	Order code*	PN (bar) ¹⁾	
																CF	71
L ³⁾	06	G 1/8 A	4	4	14	19	12.0	34.5	8	27	12	14	14	47	EW06LREDOMD	500	315
	08	G 1/4 A	6	6	19	21	14.0	37.5	12	29	12	17	19	69	EW08LREDOMD	500	315
	10	G 1/4 A	8	6	19	22	15.0	40.0	12	30	14	19	19	87	EW10LREDOMD	500	315
	12	G 3/8 A	10	9	22	24	17.0	42.0	12	32	17	22	22	122	EW12LREDOMD	400	315
	15	G 1/2 A	12	11	27	28	21.0	46.5	14	36	19	27	27	199	EW15LREDOMD	400	315
	18	G 1/2 A	15	14	27	31	23.5	50.0	14	40	24	32	27	268	EW18LREDOMD	400	315
	22	G 3/4 A	19	18	32	35	27.5	55.0	16	44	27	36	32	360	EW22LREDOMD	250	160
	28	G 1 A	24	23	40	38	30.5	59.0	18	47	36	41	41	539	EW28LREDOMD	250	160
	35	G 1 1/4 A	30	30	50	45	34.5	68.5	20	56	41	50	50	834	EW35LREDOMD	250	160
	42	G 1 1/2 A	36	36	55	51	40.0	75.0	22	63	50	60	55	1341	EW42LREDOMD	250	160
S ⁴⁾	06	G 1/4 A	4	4	19	23	16.0	40.0	12	31	12	17	19	83	EW06SREDOMD	800	630
	08	G 1/4 A	5	5	19	24	17.0	42.5	12	32	14	19	19	106	EW08SREDOMD	800	630
	10	G 3/8 A	6	7	22	25	17.5	45.0	12	34	17	22	22	148	EW10SREDOMD	800	630
	12	G 3/8 A	8	8	22	29	21.5	48.0	12	38	17	24	22	170	EW12SREDOMD	630	630
	16	G 1/2 A	12	12	27	33	24.5	55.0	14	43	24	30	27	303	EW16SREDOMD	630	400
	20	G 3/4 A	16	16	32	37	26.5	65.0	16	48	27	36	32	458	EW20SREDOMD	420	400
	25	G 1 A	20	20	40	42	30.0	73.0	18	54	36	46	41	813	EW25SREDOMD	420	400
	30	G 1 1/4 A	25	25	50	49	35.5	78.5	20	62	41	50	50	1163	EW30SREDOMD	420	400
	38	G 1 1/2 A	32	32	55	57	41.0	89.0	22	72	50	60	55	1784	EW38SREDOMD	420	315

¹⁾ Pressure shown = item deliverable

³⁾ L = light series; ⁴⁾ S = heavy series

$$\frac{\text{PN (bar)}}{10} = \text{PN (MPa)}$$

Delivery without nut and ring. Information on ordering complete fittings or alternative sealing materials see page 17.

*Please add the **suffixes** below according to the material/surface required.

Order code suffixes			
Material	Suffix surface and material	Example	Standard sealing material (no additional suffix needed)
Steel, zinc plated, Cr(VI)-free	CF	EW16SREDOMDCF	NBR
Stainless Steel	71	EW16SREDOMD71	VIT

EV-M-ED Assembled adjustable swivel 45° elbow

EO 24° cone end / Male metric thread – ED-seal (ISO 9974)

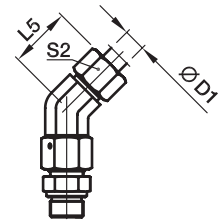
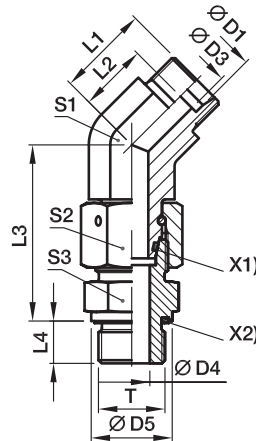

X1) O-ring OR
X2) Eolastic-sealing ED

Series	D1 	T	D3	D4	D5	L1	L2	L3	L4	L5	S1	S2	S3	Weight g/1 piece	Order code*	PN (bar) ¹⁾	
																CF	71
L ³⁾	06	M 10×1.0	4	4	14	16.0	9.0	34.5	8	24	14	14	14	44	EV06LMEDOMD	315	315
	08	M 12×1.5	6	6	17	19.0	12.0	37.5	12	27	14	17	17	62	EV08LMEDOMD	315	315
	10	M 14×1.5	8	7	19	19.0	12.0	40.0	12	27	19	19	19	80	EV10LMEDOMD	315	315
	12	M 16×1.5	10	9	22	21.0	14.0	42.0	12	29	19	22	22	110	EV12LMEDOMD	315	315
	15	M 18×1.5	12	11	24	24.0	17.0	46.0	12	32	22	27	24	171	EV15LMEDOMD	315	315
	18	M 22×1.5	15	14	27	24.0	16.5	50.0	14	33	27	32	27	245	EV18LMEDOMD	315	315
	22	M 26×1.5	19	18	32	26.0	18.5	55.0	16	35	30	36	32	339	EV22LMEDOMD	160	160
	28	M 33×2.0	24	23	40	30.5	23.0	59.0	18	40	36	41	41	517	EV28LMEDOMD	160	160
	35	M 42×2.0	30	30	50	37.0	26.5	68.5	20	48	50	50	50	810	EV35LMEDOMD	160	160
	42	M 48×2.0	36	36	55	37.0	26.0	75.0	22	49	50	60	55	1193	EV42LMEDOMD	160	160
S ⁴⁾	06	M 12×1.5	4	4	17	16.0	9.0	40.0	12	24	14	17	17	72	EV06SMEDOMD	630	630
	08	M 14×1.5	5	5	19	19.0	12.0	42.5	12	27	19	19	19	102	EV08SMEDOMD	630	630
	10	M 16×1.5	7	7	22	21.0	13.5	45.0	12	30	19	22	22	132	EV10SMEDOMD	630	630
	12	M 18×1.5	8	8	24	24.0	16.5	48.0	12	33	22	24	24	173	EV12SMEDOMD	630	630
	16	M 22×1.5	12	12	27	24.0	15.5	55.0	14	34	27	30	27	284	EV16SMEDOMD	400	400
	20	M 27×2.0	16	16	32	26.5	16.0	65.0	16	38	30	36	32	435	EV20SMEDOMD	400	400
	25	M 33×2.0	20	20	40	30.5	18.5	73.0	18	43	36	46	41	790	EV25SMEDOMD	400	400
	30	M 42×2.0	25	25	50	37.0	23.5	78.5	20	50	50	50	50	1132	EV30SMEDOMD	400	400
	38	M 48×2.0	32	32	55	37.0	21.0	89.0	22	52	50	60	55	1631	EV38SMEDOMD	315	315

¹⁾ Pressure shown = item deliverable

³⁾ L = light series; ⁴⁾ S = heavy series

$\frac{PN \text{ (bar)}}{10} = PN \text{ (MPa)}$

Delivery without nut and ring. Information on ordering complete fittings or alternative sealing materials see page 17.

*Please add the **suffixes** below according to the material/surface required.

Order code suffixes			
Material	Suffix surface and material	Example	Standard sealing material (no additional suffix needed)
Steel, zinc plated, Cr(VI)-free	CF	EV16SMEDOMDCF	NBR
Stainless Steel	71	EV16SMEDOMD71	VIT

EV-R-ED Assembled adjustable swivel 45° elbow

EO 24° cone end / Male BSPP thread – ED-seal (ISO 1179)

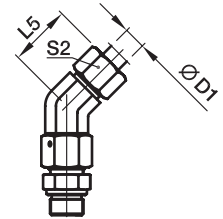
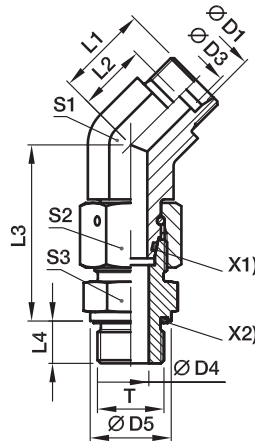

X1) O-ring OR
X2) Eolastic-sealing ED

Series	D1	T	D3	D4	D5	L1	L2	L3	L4	L5	S1	S2	S3	Weight g/1 piece	Order code*	PN (bar) ¹⁾	
																CF	71
L ³⁾	06	G 1/8 A	4	4	14	16.0	9.0	34.5	8	24	14	14	14	44	EV06LREDOMD	315	315
	08	G 1/4 A	6	6	19	19.0	12.0	37.5	12	27	14	17	19	67	EV08LREDOMD	315	315
	10	G 1/4 A	8	6	19	19.0	12.0	40.0	12	27	19	19	19	78	EV10LREDOMD	315	315
	12	G 3/8 A	10	9	22	21.0	14.0	42.0	12	29	19	22	22	112	EV12LREDOMD	315	315
	15	G 1/2 A	12	11	27	24.0	17.0	46.5	14	32	22	27	27	192	EV15LREDOMD	315	315
	18	G 1/2 A	15	14	27	24.0	16.5	50.0	14	33	27	32	27	242	EV18LREDOMD	315	315
	22	G 3/4 A	19	18	32	26.0	18.5	55.0	16	35	30	36	32	338	EV22LREDOMD	160	160
	28	G 1 A	24	23	40	30.5	23.0	59.0	18	40	36	41	41	518	EV28LREDOMD	160	160
	35	G 1 1/4 A	30	30	50	37.0	26.5	68.5	20	48	50	50	50	801	EV35LREDOMD	160	160
	42	G 1 1/2 A	36	36	55	37.0	26.0	75.0	22	49	50	60	55	1181	EV42LREDOMD	160	160
S ⁴⁾	06	G 1/4 A	4	4	19	16.0	9.0	40.0	12	24	14	17	19	78	EV06SREDOMD	630	630
	08	G 1/4 A	5	5	19	19.0	12.0	42.5	12	27	19	19	19	101	EV08SREDOMD	630	630
	10	G 3/8 A	7	7	22	21.0	13.5	45.0	12	30	19	22	22	134	EV10SREDOMD	630	630
	12	G 3/8 A	8	8	22	24.0	16.5	48.0	12	33	22	24	22	165	EV12SREDOMD	630	630
	16	G 1/2 A	12	12	27	24.0	15.5	55.0	14	34	27	30	27	280	EV16SREDOMD	400	400
	20	G 3/4 A	16	16	32	26.5	16.0	65.0	16	38	30	36	32	434	EV20SREDOMD	400	400
	25	G 1 A	20	20	40	30.5	18.5	73.0	18	43	36	46	41	792	EV25SREDOMD	400	400
	30	G 1 1/4 A	25	25	50	37.0	23.5	78.5	20	50	50	50	50	1128	EV30SREDOMD	400	400
	38	G 1 1/2 A	32	32	55	37.0	21.0	89.0	22	52	50	60	55	1625	EV38SREDOMD	315	315

¹⁾ Pressure shown = item deliverable

³⁾ L = light series; ⁴⁾ S = heavy series

$$\frac{PN \text{ (bar)}}{10} = PN \text{ (MPa)}$$

Delivery without nut and ring. Information on ordering complete fittings or alternative sealing materials see page 17.

*Please add the **suffixes** below according to the material/surface required.

Order code suffixes			
Material	Suffix surface and material	Example	Standard sealing material (no additional suffix needed)
Steel, zinc plated, Cr(VI)-free	CF	EV16SREDOMDCF	NBR
Stainless Steel	71	EV16SREDOMD71	VIT

ET-M-ED Assembled adjustable swivel branch tee

EO 24° cone end / Male metric thread – ED-seal (ISO 9974)

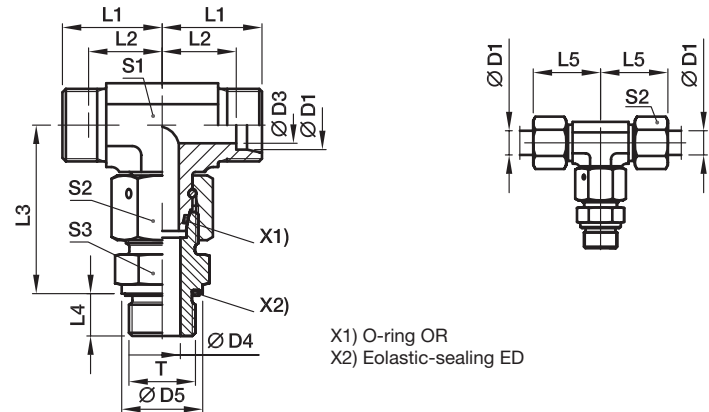

Series	D1	T	D3	D4	D5	L1	L2	L3	L4	L5	S1	S2	S3	Weight g/1 piece	Order code*	PN (bar) ¹⁾	
																CF	71
L ³⁾	06	M 10×1.0	4	4	14	19	12.0	34.5	8	27	12	14	14	55	ET06LMEDOMD	500	315
	08	M 12×1.5	6	6	17	21	14.0	37.5	12	29	12	17	17	75	ET08LMEDOMD	500	315
	10	M 14×1.5	8	7	19	22	15.0	40.0	12	30	14	19	19	98	ET10LMEDOMD	500	315
	12	M 16×1.5	10	9	22	24	17.0	42.0	12	32	17	22	22	135	ET12LMEDOMD	400	315
	15	M 18×1.5	12	11	24	28	21.0	46.0	12	36	19	27	24	203	ET15LMEDOMD	400	315
	18	M 22×1.5	15	14	27	31	23.5	50.0	14	40	24	32	27	310	ET18LMEDOMD	400	315
	22	M 26×1.5	19	18	32	35	27.5	55.0	16	44	27	36	32	377	ET22LMEDOMD	250	160
	28	M 33×2.0	24	23	40	38	30.5	59.0	18	47	36	41	41	607	ET28LMEDOMD	250	160
	35	M 42×2.0	30	30	50	45	34.5	68.5	20	56	41	50	50	929	ET35LMEDOMD	250	160
	42	M 48×2.0	36	36	55	51	40.0	75.0	22	63	50	60	55	1478	ET42LMEDOMD	250	160
S ⁴⁾	06	M 12×1.5	4	4	17	23	16.0	40.0	12	31	12	17	17	92	ET06SMEDOMD	800	630
	08	M 14×1.5	5	5	19	24	17.0	42.5	12	32	14	19	19	126	ET08SMEDOMD	800	630
	10	M 16×1.5	6	7	22	25	17.5	45.0	12	34	17	22	22	167	ET10SMEDOMD	800	630
	12	M 18×1.5	8	8	24	29	21.5	48.0	12	38	17	24	24	207	ET12SMEDOMD	630	630
	16	M 22×1.5	12	12	27	33	24.5	55.0	14	43	24	30	27	352	ET16SMEDOMD	630	400
	20	M 27×2.0	16	16	32	37	26.5	65.0	16	48	27	36	32	498	ET20SMEDOMD	420	400
	25	M 33×2.0	20	20	40	42	30.0	73.0	18	54	36	46	41	916	ET25SMEDOMD	420	400
	30	M 42×2.0	25	25	50	49	35.5	78.5	20	62	41	50	50	1328	ET30SMEDOMD	420	400
	38	M 48×2.0	32	32	55	57	41.0	89.0	22	72	50	60	55	2031	ET38SMEDOMD	420	315

¹⁾ Pressure shown = item deliverable

³⁾ L = light series; ⁴⁾ S = heavy series

$$\frac{\text{PN (bar)}}{10} = \text{PN (MPa)}$$

Delivery without nut and ring. Information on ordering complete fittings or alternative sealing materials see page 17.

*Please add the **suffixes** below according to the material/surface required.

Order code suffixes			
Material	Suffix surface and material	Example	Standard sealing material (no additional suffix needed)
Steel, zinc plated, Cr(VI)-free	CF	ET16SMEDOMDCF	NBR
Stainless Steel	71	ET16SMEDOMD71	VIT

ET-R-ED Assembled adjustable swivel branch tee

EO 24° cone end / Male BSPP thread – ED-seal (ISO 1179)

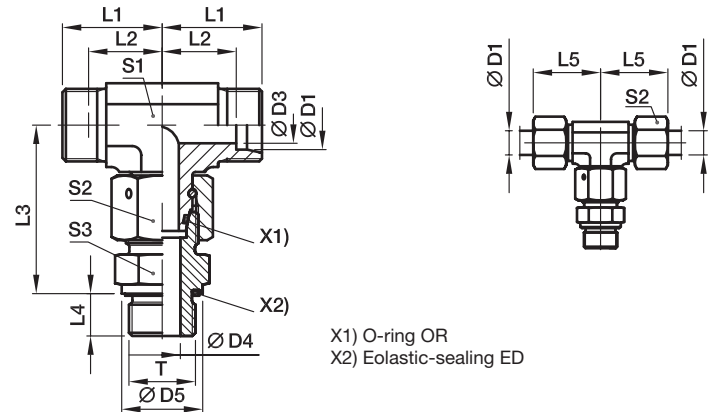

Series	D1	T	D3	D4	D5	L1	L2	L3	L4	L5	S1	S2	S3	Weight g/1 piece	Order code*	PN (bar) ¹⁾	
																CF	71
L ³⁾	06	G 1/8 A	4	4	14	19	12.0	34.5	8	27	12	14	14	55	ET06LREDDMD	500	315
	08	G 1/4 A	6	6	19	21	14.0	37.5	12	29	12	17	19	80	ET08LREDDMD	500	315
	10	G 1/4 A	8	6	19	22	15.0	40.0	12	30	14	19	19	98	ET10LREDDMD	500	315
	12	G 3/8 A	10	9	22	24	17.0	42.0	12	32	17	22	22	136	ET12LREDDMD	400	315
	15	G 1/2 A	12	11	27	28	21.0	46.5	14	36	19	27	27	224	ET15LREDDMD	400	315
	18	G 1/2 A	15	14	27	31	23.5	50.0	14	40	24	32	27	306	ET18LREDDMD	400	315
	22	G 3/4 A	19	18	32	35	27.5	55.0	16	44	27	36	32	423	ET22LREDDMD	250	160
	28	G 1 A	24	23	40	38	30.5	59.0	18	47	36	41	41	608	ET28LREDDMD	250	160
	35	G 1 1/4 A	30	30	50	45	34.5	68.5	20	56	41	50	50	920	ET35LREDDMD	250	160
	42	G 1 1/2 A	36	36	55	51	40.0	75.0	22	63	50	60	55	1466	ET42LREDDMD	250	160
S ⁴⁾	06	G 1/4 A	4	4	19	23	16.0	40.0	12	31	12	17	19	98	ET06SREDDMD	800	630
	08	G 1/4 A	5	5	19	24	17.0	42.5	12	32	14	19	19	125	ET08SREDDMD	800	630
	10	G 3/8 A	6	7	22	25	17.5	45.0	12	34	17	22	22	169	ET10SREDDMD	800	630
	12	G 3/8 A	8	8	22	29	21.5	48.0	12	38	17	24	22	198	ET12SREDDMD	630	630
	16	G 1/2 A	12	12	27	33	24.5	55.0	14	43	24	30	27	348	ET16SREDDMD	630	400
	20	G 3/4 A	16	16	32	37	26.5	65.0	16	48	27	36	32	498	ET20SREDDMD	420	400
	25	G 1 A	20	20	40	42	30.0	73.0	18	54	36	46	41	918	ET25SREDDMD	420	400
	30	G 1 1/4 A	25	25	50	49	35.5	78.5	20	62	41	50	50	1324	ET30SREDDMD	420	400
	38	G 1 1/2 A	32	32	55	57	41.0	89.0	22	72	50	60	55	2025	ET38SREDDMD	420	315

¹⁾ Pressure shown = item deliverable

³⁾ L = light series; ⁴⁾ S = heavy series

$$\frac{PN(\text{bar})}{10} = PN(\text{MPa})$$

Delivery without nut and ring. Information on ordering complete fittings or alternative sealing materials see page 17.

*Please add the **suffixes** below according to the material/surface required

Order code suffixes			
Material	Suffix surface and material	Example	Standard sealing material (no additional suffix needed)
Steel, zinc plated, Cr(VI)-free	CF	ET16SREDDMDCF	NBR
Stainless Steel	71	ET16SREDDMD71	VIT

EL-M-ED Assembled adjustable swivel run tee

EO 24° cone end / Male metric thread – ED-seal (ISO 9974)

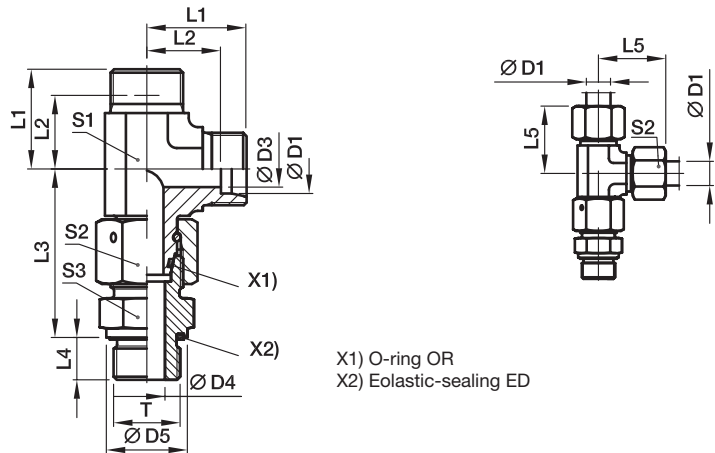

X1) O-ring OR
X2) Elastic-sealing ED

Series	D1	T	D3	D4	D5	L1	L2	L3	L4	L5	S1	S2	S3	Weight g/1 piece	Order code*	PN (bar) ¹⁾	
																CF	71
L ³⁾	06	M 10×1.0	4	4	14	19	12.0	34.5	8	27	12	14	14	55	EL06LMEDOMD	500	315
	08	M 12×1.5	6	6	17	21	14.0	37.5	12	29	12	17	17	75	EL08LMEDOMD	500	315
	10	M 14×1.5	8	7	19	22	15.0	40.0	12	30	14	19	19	97	EL10LMEDOMD	500	315
	12	M 16×1.5	10	9	22	24	17.0	42.0	12	32	17	22	22	135	EL12LMEDOMD	400	315
	15	M 18×1.5	12	11	24	28	21.0	46.0	12	36	19	27	24	201	EL15LMEDOMD	400	315
	18	M 22×1.5	15	14	27	31	23.5	50.0	14	40	24	32	27	308	EL18LMEDOMD	400	315
	22	M 26×1.5	19	18	32	35	27.5	55.0	16	44	27	36	32	404	EL22LMEDOMD	250	160
	28	M 33×2.0	24	23	40	38	30.5	59.0	18	47	36	41	41	605	EL28LMEDOMD	250	160
	35	M 42×2.0	30	30	50	45	34.5	68.5	20	56	41	50	50	947	EL35LMEDOMD	250	160
	42	M 48×2.0	36	36	55	51	40.0	75.0	22	63	50	60	55	1497	EL42LMEDOMD	250	160
S ⁴⁾	06	M 12×1.5	4	4	17	23	16.0	40.0	12	31	12	17	17	91	EL06SMEDOMD	800	630
	08	M 14×1.5	5	5	19	24	17.0	42.5	12	32	14	19	19	126	EL08SMEDOMD	800	630
	10	M 16×1.5	6	7	22	25	17.5	45.0	12	34	17	22	22	169	EL10SMEDOMD	800	630
	12	M 18×1.5	8	8	24	29	21.5	48.0	12	38	17	24	24	206	EL12SMEDOMD	630	630
	16	M 22×1.5	12	12	27	33	24.5	55.0	14	43	24	30	27	354	EL16SMEDOMD	630	400
	20	M 27×2.0	16	16	32	37	26.5	65.0	16	48	27	36	32	526	EL20SMEDOMD	420	400
	25	M 33×2.0	20	20	40	42	30.0	73.0	18	54	36	46	41	919	EL25SMEDOMD	420	400
	30	M 42×2.0	25	25	50	49	35.5	78.5	20	62	41	50	50	1328	EL30SMEDOMD	420	400
	38	M 48×2.0	32	32	55	57	41.0	89.0	22	72	50	60	55	2039	EL38SMEDOMD	420	315

¹⁾ Pressure shown = item deliverable

³⁾ L = light series; ⁴⁾ S = heavy series

$$\frac{\text{PN (bar)}}{10} = \text{PN (MPa)}$$

Delivery without nut and ring. Information on ordering complete fittings or alternative sealing materials see page 17.

*Please add the **suffixes** below according to the material/surface required.

Order code suffixes			
Material	Suffix surface and material	Example	Standard sealing material (no additional suffix needed)
Steel, zinc plated, Cr(VI)-free	CF	EL16SMEDOMDCF	NBR
Stainless Steel	71	EL16SMEDOMD71	VIT

EL-R-ED Assembled adjustable swivel run tee

EO 24° cone end / Male BSPP thread – ED-seal (ISO 1179)

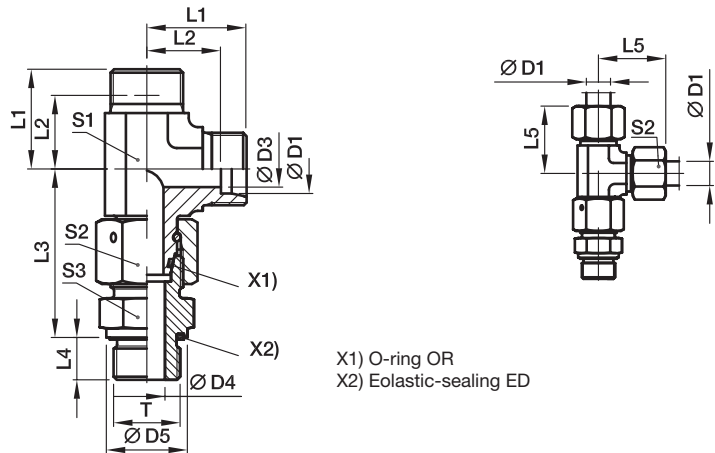

Series	D1	T	D3	D4	D5	L1	L2	L3	L4	L5	S1	S2	S3	Weight g/1 piece	Order code*	PN (bar) ¹⁾	
																CF	71
L ³⁾	06	G 1/8 A	4	4	14	19	12.0	34.5	8	27	12	14	14	55	EL06LREDOMD	500	315
	08	G 1/4 A	6	6	19	21	14.0	37.5	12	29	12	17	19	80	EL08LREDOMD	500	315
	10	G 1/4 A	8	6	19	22	15.0	40.0	12	30	14	19	19	97	EL10LREDOMD	500	315
	12	G 3/8 A	10	9	22	24	17.0	42.0	12	32	17	22	22	137	EL12LREDOMD	400	315
	15	G 1/2 A	12	11	27	28	21.0	46.5	14	36	19	27	27	222	EL15LREDOMD	400	315
	18	G 1/2 A	15	14	27	31	23.5	50.0	14	40	24	32	27	304	EL18LREDOMD	400	315
	22	G 3/4 A	19	18	32	35	27.5	55.0	16	44	27	36	32	404	EL22LREDOMD	250	160
	28	G 1 A	24	23	40	38	30.5	59.0	18	47	36	41	41	606	EL28LREDOMD	250	160
	35	G 1 1/4 A	30	30	50	45	34.5	68.5	20	56	41	50	50	938	EL35LREDOMD	250	160
	42	G 1 1/2 A	36	36	55	51	40.0	75.0	22	63	50	60	55	1485	EL42LREDOMD	250	160
S ⁴⁾	06	G 1/4 A	4	4	19	23	16.0	40.0	12	31	12	17	19	97	EL06SREDOMD	800	630
	08	G 1/4 A	5	5	19	24	17.0	42.5	12	32	14	19	19	125	EL08SREDOMD	800	630
	10	G 3/8 A	6	7	22	25	17.5	45.0	12	34	17	22	22	171	EL10SREDOMD	800	630
	12	G 3/8 A	8	8	22	29	21.5	48.0	12	38	17	24	22	198	EL12SREDOMD	630	630
	16	G 1/2 A	12	12	27	33	24.5	55.0	14	43	24	30	27	350	EL16SREDOMD	630	400
	20	G 3/4 A	16	16	32	37	26.5	65.0	16	48	27	36	32	524	EL20SREDOMD	420	400
	25	G 1 A	20	20	40	42	30.0	73.0	18	54	36	46	41	921	EL25SREDOMD	420	400
	30	G 1 1/4 A	25	25	50	49	35.5	78.5	20	62	41	50	50	1324	EL30SREDOMD	420	400
	38	G 1 1/2 A	32	32	55	57	41.0	89.0	22	72	50	60	55	2033	EL38SREDOMD	420	315

¹⁾ Pressure shown = item deliverable

³⁾ L = light series; ⁴⁾ S = heavy series

$$\frac{PN(\text{bar})}{10} = PN(\text{MPa})$$

Delivery without nut and ring. Information on ordering complete fittings or alternative sealing materials see page 17.

*Please add the **suffixes** below according to the material/surface required.

Order code suffixes			
Material	Suffix surface and material	Example	Standard sealing material (no additional suffix needed)
Steel, zinc plated, Cr(VI)-free	CF	EL16SREDOMDCF	NBR
Stainless Steel	71	EL16SREDOMD71	VIT

EVW-M Assembled adjustable standpipe elbow

EO 24° cone end / Male metric thread – metal sealing edge (ISO 9974)

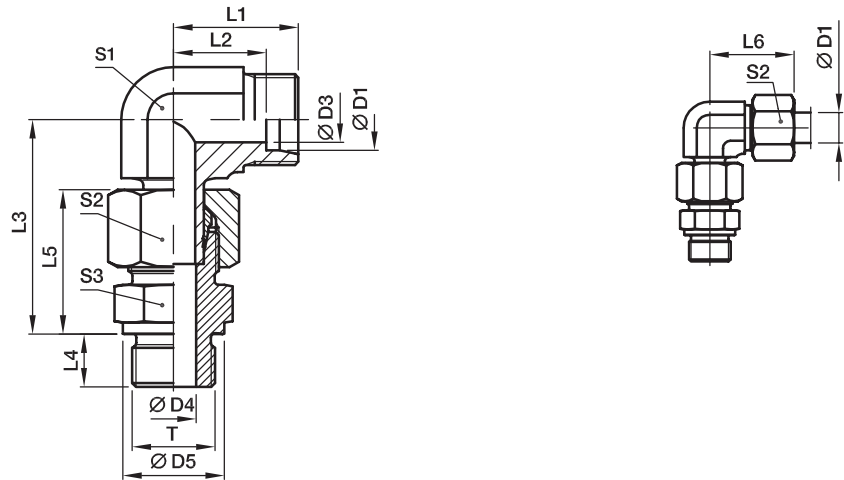

Pre-assembled, complete with straight male stud connector (with cutting face DIN 3852, type B). Final assembly (in appropriate body) at least 1/4 turn beyond the point of clearly perceptible resistance.

Series	D1	T	D3	D4	D5	L1	L2	L3	L4	L5	L6	S1	S2	S3	Weight g/1 piece	Order code*	PN (bar) ¹⁾	
																	CF	71
L ³⁾	06	M 10×1.0	4	4	14	19	12.0	34.5	8	23	27	12	14	14	41	EVW06LMOMD	315	315
	08	M 12×1.5	6	6	17	21	14.0	37.5	12	25	29	12	17	17	63	EVW08LMOMD	315	315
	10	M 14×1.5	8	7	19	22	15.0	40.0	12	26	30	14	19	19	83	EVW10LMOMD	315	315
	12	M 16×1.5	10	9	21	24	17.0	42.0	12	27	32	17	22	22	107	EVW12LMOMD	315	315
	15	M 18×1.5	12	11	23	28	21.0	46.0	12	29	36	19	27	24	170	EVW15LMOMD	250	250
	18	M 22×1.5	15	14	27	31	23.5	50.0	14	31	40	24	32	27	265	EVW18LMOMD	250	250
	22	M 26×1.5	19	18	31	35	27.5	55.0	16	33	44	27	36	32	355	EVW22LMOMD	160	160
	28	M 33×2.0	24	23	39	38	30.5	59.5	18	34	47	36	41	41	514	EVW28LMOMD	160	160
	35	M 42×2.0	30	30	49	45	34.5	68.5	20	39	56	41	50	50	791	EVW35LMOMD	160	160
	42	M 48×2.0	36	36	55	51	40.0	79.0	22	42	63	50	60	55	1153	EVW42LMOMD	160	160
S ⁴⁾	06	M 12×1.5	4	4	17	23	16.0	40.0	12	28	31	12	17	17	73	EVW06SMOMD	400	400
	08	M 14×1.5	5	5	19	24	17.0	42.5	12	30	32	14	19	19	100	EVW08SMOMD	400	400
	10	M 16×1.5	7	7	21	25	17.5	46.0	12	31	34	17	22	22	133	EVW10SMOMD	400	400
	12	M 18×1.5	8	8	23	29	21.5	48.0	12	33	38	17	24	24	174	EVW12SMOMD	400	400
	16	M 22×1.5	12	12	27	33	24.5	56.0	14	37	43	24	30	27	309	EVW16SMOMD	400	400
	20	M 27×2.0	16	16	32	37	26.5	65.0	16	42	48	27	36	32	429	EVW20SMOMD	400	400
	25	M 33×2.0	20	20	39	42	30.0	73.0	18	47	54	36	46	41	826	EVW25SMOMD	250	250
	30	M 42×2.0	25	25	49	49	35.5	78.5	20	50	62	41	50	50	1132	EVW30SMOMD	160	160
	38	M 48×2.0	32	32	55	57	41.0	92.5	22	57	72	50	60	55	1874	EVW38SMOMD	160	160

¹⁾ Pressure shown = item deliverable

³⁾ L = light series; ⁴⁾ S = heavy series

$$\frac{\text{PN (bar)}}{10} = \text{PN (MPa)}$$

Delivery without nut and ring. Information on ordering complete fittings see page 17.

*Please add the **suffixes** below according to the material/surface required.

Order code suffixes		
Material	Suffix surface and material	Example
Steel, zinc plated, Cr(VI)-free	CF	EVW16SMOMDCF
Stainless Steel	71	EVW16SMOMD71

EVW-R Assembled adjustable standpipe elbow

EO 24° cone end / Male BSPP thread – metal sealing edge (ISO 1179)

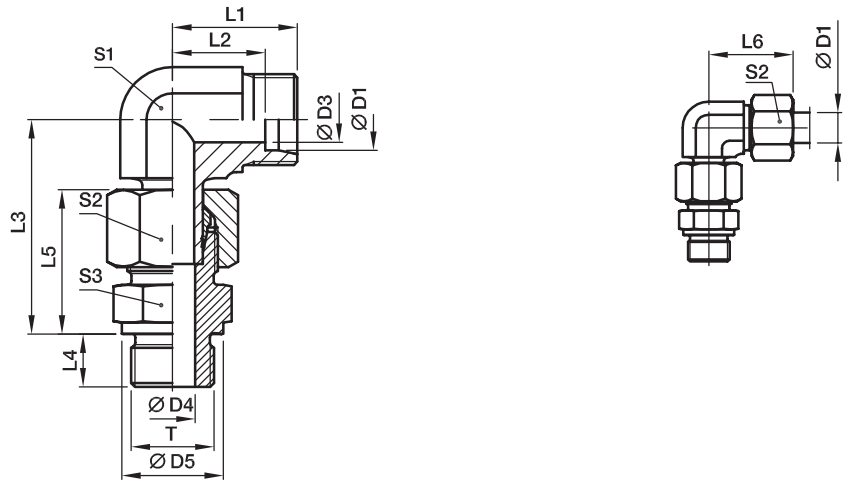

Pre-assembled, complete with straight male stud connector (with cutting face DIN 3852, type B). Final assembly (in appropriate body) at least 1/4 turn beyond the point of clearly perceptible resistance.

Series	D1	T	D3	D4	D5	L1	L2	L3	L4	L5	L6	S1	S2	S3	Weight g/1 piece	Order code*	PN (bar) ¹⁾	
																	CF	71
L ³⁾	06	G 1/8 A	4	4	14	19	12.0	34.5	8	23	27	12	14	14	47	EVW06LROMD	315	315
	08	G 1/4 A	6	6	18	21	14.0	37.5	12	25	29	12	17	19	68	EVW08LROMD	315	315
	10	G 1/4 A	8	6	18	22	15.0	40.0	12	26	30	14	19	19	84	EVW10LROMD	315	315
	12	G 3/8 A	10	9	22	24	17.0	42.0	12	27	32	17	22	22	118	EVW12LROMD	315	315
	15	G 1/2 A	12	11	26	28	21.0	46.5	14	29	36	19	27	27	191	EVW15LROMD	250	250
	18	G 1/2 A	15	14	26	31	23.5	50.0	14	31	40	24	32	27	260	EVW18LROMD	250	250
	22	G 3/4 A	19	18	32	35	27.5	55.0	16	33	44	27	36	32	355	EVW22LROMD	160	160
	28	G 1 A	24	23	39	38	30.5	59.5	18	34	47	36	41	41	542	EVW28LROMD	160	160
	35	G 1 1/4 A	30	30	49	45	34.5	68.5	20	39	56	41	50	50	832	EVW35LROMD	160	160
	42	G 1 1/2 A	36	36	55	51	40.0	79.0	22	42	63	50	60	55	1303	EVW42LROMD	160	160
S ⁴⁾	06	G 1/4 A	4	4	18	23	16.0	40.0	12	28	31	12	17	19	79	EVW06SROMD	400	400
	08	G 1/4 A	5	5	18	24	17.0	42.5	12	30	32	14	19	19	98	EVW08SROMD	400	400
	10	G 3/8 A	7	7	22	25	17.5	46.0	12	31	34	17	22	22	148	EVW10SROMD	400	400
	12	G 3/8 A	8	8	22	29	21.5	48.0	12	33	38	17	24	22	169	EVW12SROMD	400	400
	16	G 1/2 A	12	12	26	33	24.5	56.0	14	37	43	24	30	27	304	EVW16SROMD	400	400
	20	G 3/4 A	16	16	32	37	26.5	65.0	16	42	48	27	36	32	428	EVW20SROMD	400	400
	25	G 1 A	20	20	39	42	30.0	73.0	18	47	54	36	46	41	825	EVW25SROMD	250	250
	30	G 1 1/4 A	25	25	49	49	35.5	78.5	20	50	62	41	50	50	1134	EVW30SROMD	160	160
	38	G 1 1/2 A	32	32	55	57	41.0	92.5	22	57	72	50	60	55	1713	EVW38SROMD	160	160

¹⁾ Pressure shown = item deliverable

³⁾ L = light series; ⁴⁾ S = heavy series

$$\frac{\text{PN (bar)}}{10} = \text{PN (MPa)}$$

Delivery without nut and ring. Information on ordering complete fittings see page I7.

*Please add the **suffixes** below according to the material/surface required.

Order code suffixes		
Material	Suffix surface and material	Example
Steel, zinc plated, Cr(VI)-free	CF	EVW16SROMDCF
Stainless Steel	71	EVW16SROMD71

EVT-M Assembled adjustable standpipe branch tee

EO 24° cone end / Male metric thread – metal sealing edge (ISO 9974)

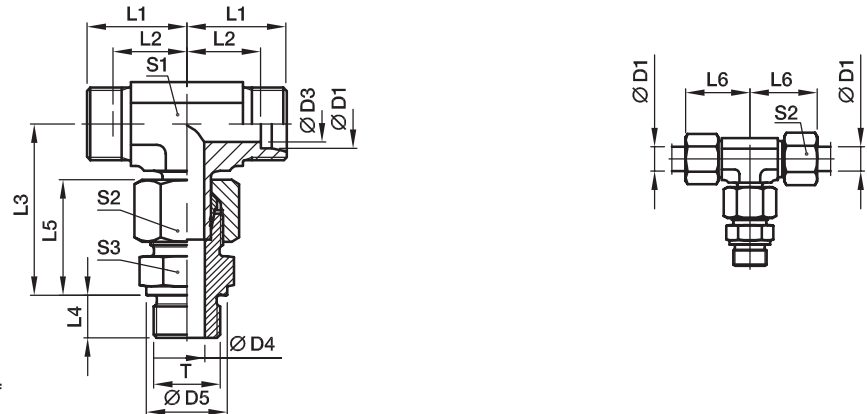

Pre-assembled, complete with straight male stud connector (with cutting face). Final assembly (in appropriate body) at least 1/4 turn beyond the point of clearly perceptible resistance.

Series	D1	T	D3	D4	D5	L1	L2	L3	L4	L5	L6	S1	S2	S3	Weight g/1 piece	Order code*	PN (bar) ¹⁾	
																	CF	71
L ³⁾	06	M 10×1.0	4	4	14	19	12.0	34.5	8	23	27	12	14	14	48	EVT06LMOMD	315	315
	08	M 12×1.5	6	6	17	21	14.0	37.5	12	25	29	12	17	17	68	EVT08LMOMD	315	315
	10	M 14×1.5	8	7	19	22	15.0	40.0	12	26	30	14	19	19	88	EVT10LMOMD	315	315
	12	M 16×1.5	10	9	21	24	17.0	43.0	12	27	32	17	22	22	116	EVT12LMOMD	315	315
	15	M 18×1.5	12	11	23	28	21.0	46.0	12	29	36	19	27	24	185	EVT15LMOMD	250	250
	18	M 22×1.5	15	14	27	31	23.5	50.0	14	31	40	24	32	27	272	EVT18LMOMD	250	250
	22	M 26×1.5	19	18	31	35	27.5	55.5	16	33	44	27	36	32	367	EVT22LMOMD	160	160
	28	M 33×2.0	24	23	39	38	30.5	61.0	18	34	47	36	41	41	565	EVT28LMOMD	160	160
	35	M 42×2.0	30	30	49	45	34.5	72.0	20	39	56	41	50	50	905	EVT35LMOMD	160	160
	42	M 48×2.0	36	36	55	51	40.0	79.0	22	42	63	50	60	55	1282	EVT42LMOMD	160	160
S ⁴⁾	06	M 12×1.5	4	4	17	23	16.0	40.0	12	28	31	12	17	17	85	EVT06SMOMD	400	400
	08	M 14×1.5	5	5	19	24	17.0	44.0	12	30	32	14	19	19	118	EVT08SMOMD	400	400
	10	M 16×1.5	7	7	21	25	17.5	47.0	12	31	34	17	22	22	149	EVT10SMOMD	400	400
	12	M 18×1.5	8	8	23	29	21.5	50.0	12	33	38	17	24	24	200	EVT12SMOMD	400	400
	16	M 22×1.5	12	12	27	33	24.5	55.0	14	37	43	24	30	27	327	EVT16SMOMD	400	400
	20	M 27×2.0	16	16	32	37	26.5	65.0	16	42	48	27	36	32	482	EVT20SMOMD	400	400
	25	M 33×2.0	20	20	39	42	30.0	73.5	18	47	54	36	46	41	906	EVT25SMOMD	250	250
	30	M 42×2.0	25	25	49	49	35.5	80.0	20	50	62	41	50	50	1274	EVT30SMOMD	160	160
	38	M 48×2.0	32	32	55	57	41.0	92.5	22	57	72	50	60	55	1928	EVT38SMOMD	160	160

¹⁾ Pressure shown = item deliverable

³⁾ L = light series; ⁴⁾ S = heavy series

$\frac{\text{PN (bar)}}{10} = \text{PN (MPa)}$

Delivery without nut and ring. Information on ordering complete fittings see page 17.

*Please add the **suffixes** below according to the material/surface required.

Order code suffixes		
Material	Suffix surface and material	Example
Steel, zinc plated, Cr(VI)-free	CF	EVT16SMOMDCF
Stainless Steel	71	EVT16SMOMD71

EVT-R Assembled adjustable standpipe branch tee

EO 24° cone end / Male BSPP thread – metal sealing edge (ISO 1179)

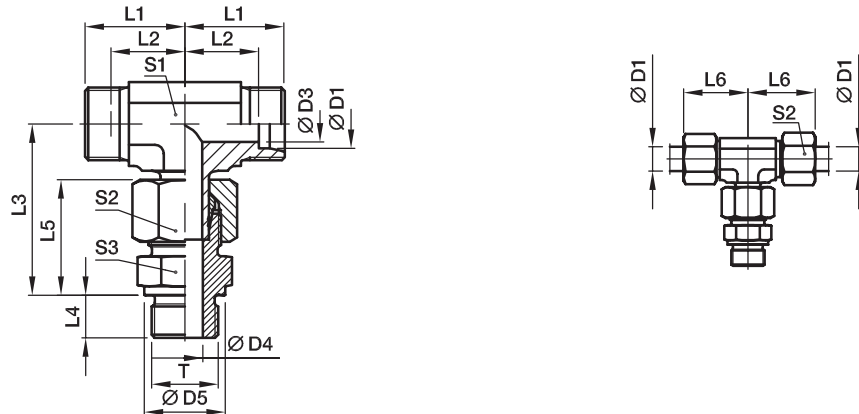

Pre-assembled, complete with straight male stud connector (with cutting face). Final assembly (in appropriate body) at least 1/4 turn beyond the point of clearly perceptible resistance.

Series	D1	T	D3	D4	D5	L1	L2	L3	L4	L5	L6	S1	S2	S3	Weight g/1 piece	Order code*	PN (bar) ¹⁾	
																	CF	71
L ³⁾	06	G 1/8 A	4	4	14	19	12.0	34.5	8	23	27	12	14	14	48	EVT06LROMD	315	315
	08	G 1/4 A	6	6	18	21	14.0	37.5	12	25	29	12	17	19	73	EVT08LROMD	315	315
	10	G 1/4 A	8	6	18	22	15.0	40.0	12	26	30	14	19	19	85	EVT10LROMD	315	315
	12	G 3/8 A	10	9	22	24	17.0	43.0	12	27	32	17	22	22	118	EVT12LROMD	315	315
	15	G 1/2 A	12	11	26	28	21.0	46.5	14	29	36	19	27	27	206	EVT15LROMD	250	250
	18	G 1/2 A	15	14	26	31	23.5	50.0	14	31	40	24	32	27	267	EVT18LROMD	250	250
	22	G 3/4 A	19	18	32	35	27.5	55.5	16	33	44	27	36	32	367	EVT22LROMD	160	160
	28	G 1 A	24	23	39	38	30.5	61.0	18	34	47	36	41	41	565	EVT28LROMD	160	160
	35	G 1 1/4 A	30	30	49	45	34.5	72.0	20	39	56	41	50	50	901	EVT35LROMD	160	160
	42	G 1 1/2 A	36	36	55	51	40.0	79.0	22	42	63	50	60	55	1277	EVT42LROMD	160	160
S ⁴⁾	06	G 1/4 A	4	4	18	23	16.0	40.0	12	28	31	12	17	19	90	EVT06SROMD	400	400
	08	G 1/4 A	5	5	18	24	17.0	44.0	12	30	32	14	19	19	116	EVT08SROMD	400	400
	10	G 3/8 A	7	7	22	25	17.5	47.0	12	31	34	17	22	22	151	EVT10SROMD	400	400
	12	G 3/8 A	8	8	22	29	21.5	50.0	12	33	38	17	24	22	190	EVT12SROMD	400	400
	16	G 1/2 A	12	12	26	33	24.5	55.0	14	37	43	24	30	27	322	EVT16SROMD	400	400
	20	G 3/4 A	16	16	32	37	26.5	65.0	16	42	48	27	36	32	500	EVT20SROMD	400	400
	25	G 1 A	20	20	39	42	30.0	73.5	18	47	54	36	46	41	905	EVT25SROMD	250	250
	30	G 1 1/4 A	25	25	49	49	35.5	80.0	20	50	62	41	50	50	1275	EVT30SROMD	160	160
	38	G 1 1/2 A	32	32	55	57	41.0	92.5	22	57	72	50	60	55	1920	EVT38SROMD	160	160

¹⁾ Pressure shown = item deliverable

³⁾ L = light series; ⁴⁾ S = heavy series

$$\frac{\text{PN (bar)}}{10} = \text{PN (MPa)}$$

Delivery without nut and ring. Information on ordering complete fittings see page I7.

*Please add the **suffixes** below according to the material/surface required.

Order code suffixes		
Material	Suffix surface and material	Example
Steel, zinc plated, Cr(VI)-free	CF	EVT16SROMDCF
Stainless Steel	71	EVT16SROMD71

EVL-M Assembled adjustable standpipe run tee

EO 24° cone end / Male metric thread – metal sealing edge (ISO 9974)

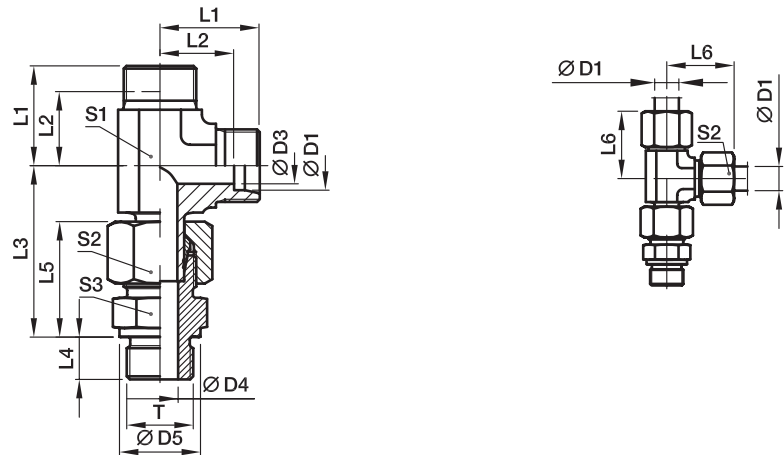

Pre-assembled, complete with straight male stud connector (with cutting face). Final assembly (in appropriate body) at least 1/4 turn beyond the point of clearly perceptible resistance.

Series	D1	T	D3	D4	D5	L1	L2	L3	L4	L5	L6	S1	S2	S3	Weight g/1 piece	Order code*	PN (bar) ¹⁾	
																	CF	71
L ³⁾	06	M 10×1.0	4	4	14	19	12.0	34.5	8	23	27	12	14	14	48	EVL06LMOMD	315	315
	08	M 12×1.5	6	6	17	21	14.0	37.5	12	25	29	12	17	17	73	EVL08LMOMD	315	315
	10	M 14×1.5	8	7	19	22	15.0	40.0	12	26	30	14	19	19	89	EVL10LMOMD	315	315
	12	M 16×1.5	10	9	21	24	17.0	43.0	12	27	32	17	22	22	118	EVL12LMOMD	315	315
	15	M 18×1.5	12	11	23	28	21.0	46.0	12	29	36	19	27	24	186	EVL15LMOMD	250	250
	18	M 22×1.5	15	14	27	31	23.5	50.0	14	31	40	24	32	27	269	EVL18LMOMD	250	250
	22	M 26×1.5	19	18	31	35	27.5	55.5	16	33	44	27	36	32	364	EVL22LMOMD	160	160
	28	M 33×2.0	24	23	39	38	30.5	61.0	18	34	47	36	41	41	556	EVL28LMOMD	160	160
	35	M 42×2.0	30	30	49	45	34.5	72.0	20	39	56	41	50	50	900	EVL35LMOMD	160	160
	42	M 48×2.0	36	36	55	51	40.0	79.0	22	42	63	50	60	55	1323	EVL42LMOMD	160	160
S ⁴⁾	06	M 12×1.5	4	4	17	23	16.0	40.0	12	28	31	12	17	17	85	EVL06SMOMD	400	400
	08	M 14×1.5	5	5	19	24	17.0	44.0	12	30	32	14	19	19	119	EVL08SMOMD	400	400
	10	M 16×1.5	7	7	21	25	17.5	47.0	12	31	34	17	22	22	151	EVL10SMOMD	400	400
	12	M 18×1.5	8	8	23	29	21.5	50.0	12	33	38	17	24	24	202	EVL12SMOMD	400	400
	16	M 22×1.5	12	12	27	33	24.5	56.0	14	37	43	24	30	27	326	EVL16SMOMD	400	400
	20	M 27×2.0	16	16	32	37	26.5	65.0	16	42	48	27	36	32	481	EVL20SMOMD	400	400
	25	M 33×2.0	20	20	39	42	30.0	73.5	18	47	54	36	46	41	904	EVL25SMOMD	250	250
	30	M 42×2.0	25	25	49	49	35.5	80.0	20	50	62	41	50	50	1263	EVL30SMOMD	160	160
	38	M 48×2.0	32	32	55	57	41.0	92.5	22	57	72	50	60	55	1936	EVL38SMOMD	160	160

¹⁾ Pressure shown = item deliverable

³⁾ L = light series; ⁴⁾ S = heavy series

$$\frac{\text{PN (bar)}}{10} = \text{PN (MPa)}$$

Delivery without nut and ring. Information on ordering complete fittings see page 17.

*Please add the **suffixes** below according to the material/surface required.

Order code suffixes		
Material	Suffix surface and material	Example
Steel, zinc plated, Cr(VI)-free	CF	EVL16SMOMDCF
Stainless Steel	71	EVL16SMOMD71

EVL-R Assembled adjustable standpipe run tee

EO 24° cone end / Male BSPP thread – metal sealing edge (ISO 1179)

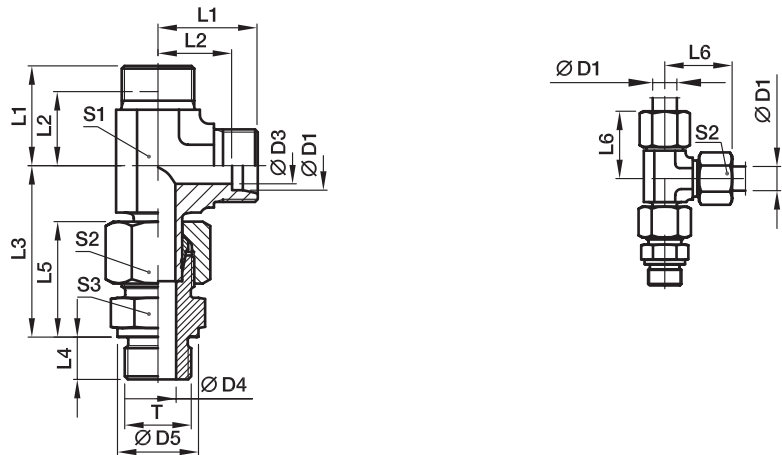

Pre-assembled, complete with straight male stud connector (with cutting face). Final assembly (in appropriate body) at least 1/4 turn beyond the point of clearly perceptible resistance.

Series	D1	T	D3	D4	D5	L1	L2	L3	L4	L5	L6	S1	S2	S3	Weight g/1 piece	Order code*	PN (bar) ¹⁾	
																	CF	71
L ³⁾	06	G 1/8 A	4	4	14	19	12.0	34.5	8	23	27	12	14	14	48	EVL06LROMD	315	315
	08	G 1/4 A	6	6	18	21	14.0	37.5	12	25	29	12	17	19	73	EVL08LROMD	315	315
	10	G 1/4 A	8	6	18	22	15.0	40.0	12	26	30	14	19	19	87	EVL10LROMD	315	315
	12	G 3/8 A	10	9	22	24	17.0	43.0	12	27	32	17	22	22	120	EVL12LROMD	315	315
	15	G 1/2 A	12	11	26	28	21.0	46.5	14	29	36	19	27	27	207	EVL15LROMD	250	250
	18	G 1/2 A	15	14	26	31	23.5	50.0	14	31	40	24	32	27	264	EVL18LROMD	250	250
	22	G 3/4 A	19	18	32	35	27.5	55.5	16	33	44	27	36	32	365	EVL22LROMD	160	160
	28	G 1 A	24	23	39	38	30.5	61.0	18	34	47	36	41	41	556	EVL28LROMD	160	160
	35	G 1 1/4 A	30	30	49	45	34.5	72.0	20	39	56	41	50	50	895	EVL35LROMD	160	160
	42	G 1 1/2 A	36	36	55	51	40.0	79.0	22	42	63	50	60	55	1318	EVL42LROMD	160	160
S ⁴⁾	06	G 1/4 A	4	4	18	23	16.0	40.0	12	28	31	12	17	19	90	EVL06SROMD	400	400
	08	G 1/4 A	5	5	18	24	17.0	44.0	12	30	32	14	19	19	117	EVL08SROMD	400	400
	10	G 3/8 A	7	7	22	25	17.5	47.0	12	31	34	17	22	22	153	EVL10SROMD	400	400
	12	G 3/8 A	8	8	22	29	21.5	50.0	12	33	38	17	24	22	192	EVL12SROMD	400	400
	16	G 1/2 A	12	12	26	33	24.5	56.0	14	37	43	24	30	27	321	EVL16SROMD	400	400
	20	G 3/4 A	16	16	32	37	26.5	65.0	16	42	48	27	36	32	480	EVL20SROMD	400	400
	25	G 1 A	20	20	39	42	30.0	73.5	18	47	54	36	46	41	903	EVL25SROMD	250	250
	30	G 1 1/4 A	25	25	49	49	35.5	80.0	20	50	62	41	50	50	1265	EVL30SROMD	160	160
	38	G 1 1/2 A	32	32	55	57	41.0	92.5	22	57	72	50	60	55	1928	EVL38SROMD	160	160

¹⁾ Pressure shown = item deliverable

³⁾ L = light series; ⁴⁾ S = heavy series

$$\frac{\text{PN (bar)}}{10} = \text{PN (MPa)}$$

Delivery without nut and ring. Information on ordering complete fittings see page I7.

*Please add the **suffixes** below according to the material/surface required.

Order code suffixes		
Material	Suffix surface and material	Example
Steel, zinc plated, Cr(VI)-free	CF	EVL16SROMDCF
Stainless Steel	71	EVL16SROMD71

WEE-R Adjustable locknut elbow

EO 24° cone end / Adjustable BSPP thread – O-ring + retaining ring (ISO 1179)
 for ports with small or wide spot face;
 differences in D5 in Stainless Steel are only for ports with wide spot face
 (e.g. WEE16SRBOMD71)

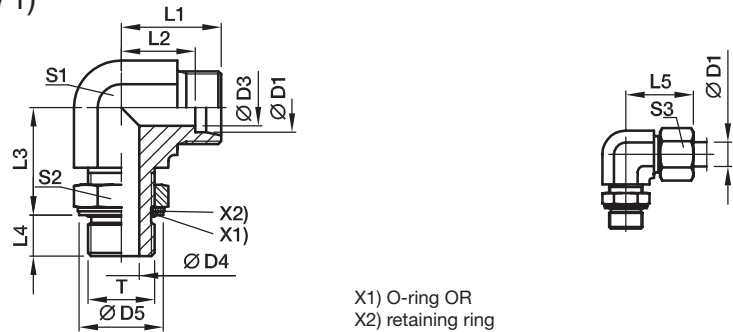

Series	D1	T	D3	D4	D5 ⁵⁾	D5 ⁶⁾	L1	L2	L3	L4	L5	S1	S2	S3	Weight g/1 piece	Order code*	PN (bar) ¹⁾	
																	CF	71
LL ²⁾	04	G 1/8 A	3.0	4.5	15		15	11.3	20	7.1	21	12	14	10	27	WEE04LLROMD	100	
	06	G 1/8 A	4.5	4.5	15		15	11.3	20	7.1	21	12	14	12	27	WEE06LLROMD	100	
L ³⁾	06	G 1/8 A	4.0	4.5	15	15.0	21	14.0	19	7.0	29	14	14	14	40	WEE06LROMD	315	315
	08	G 1/4 A	6.0	7.5	20	19.5	23	16.0	23	9.0	31	14	19	17	59	WEE08LROMD	315	315
	10	G 1/4 A	8.0	7.5	20	19.5	24	17.0	25	9.0	32	19	19	19	82	WEE10LROMD	315	315
	12	G 3/8 A	10.0	10.0	23	23.5	26	19.0	28	9.0	34	19	22	22	96	WEE12LROMD	250	250
	15	G 1/2 A	12.0	12.5	28	28.5	28	21.0	30	13.0	36	22	27	27	149	WEE15LROMD	250	250
	18	G 1/2 A	15.0	12.5	28	28.5	31	24.0	36	13.0	40	27	27	32	221	WEE18LROMD	250	250
	22	G 3/4 A	19.0	15.5	33	34.5	35	28.0	36	13.0	44	30	36	36	310	WEE22LROMD	160	160
	28	G 1 A	24.0	21.5	41	43.5	38	31.0	44	15.0	47	36	41	41	455	WEE28LROMD	160	160
	35	G 1 1/4 A	30.0	27.5	51	52.5	48	38.0	50	15.0	59	50	50	50	1043	WEE35LROMD	160	160
	42	G 1 1/2 A	36.0	33.0	56	60.0	49	38.0	52	15.0	61	50	55	60	994	WEE42LROMD	160	160
S ⁴⁾	06	G 1/4 A	4.0	7.5	20	19.5	22	15.0	23	9.0	30	14	19	17	56	WEE06SROMD	315	315
	08	G 1/4 A	5.0	7.5	20	19.5	24	17.0	27	9.0	32	19	19	19	88	WEE08SROMD	315	315
	10	G 3/8 A	7.0	10.0	23	23.5	25	18.0	29	9.0	34	19	22	22	98	WEE10SROMD	250	250
	12	G 3/8 A	8.0	10.0	23	23.5	29	22.0	29	9.0	38	22	22	24	128	WEE12SROMD	250	250
	16	G 1/2 A	12.0	12.5	28	28.5	33	25.0	36	13.0	43	27	27	30	234	WEE16SROMD	250	250
	20	G 3/4 A	16.0	15.5	33	34.5	38	28.0	39	12.0	49	30	36	36	344	WEE20SROMD	250	250
	25	G 1 A	20.0	21.5	41	43.5	42	30.0	44	14.0	54	36	41	46	533	WEE25SROMD	250	250
	30	G 1 1/4 A	25.0	27.5	51	52.5	49	36.0	49	15.0	62	50	50	50	1085	WEE30SROMD	160	160
	38	G 1 1/2 A	32.0	33.0	56	60.0	50	34.0	55	15.0	65	50	55	60	1116	WEE38SROMD	160	160

1) Pressure shown = item deliverable

2) LL = very light series; 3) L = light series; 4) S = heavy series

$$\frac{\text{PN (bar)}}{10} = \text{PN (MPa)}$$

Delivery without nut and ring. Information on ordering complete fittings or alternative sealing materials see page 17.

5) Steel; 6) Stainless Steel

*Please add the **suffixes** below according to the material/surface required.

Order code suffixes			
Material	Suffix surface and material	Example	Standard sealing material (no additional suffix needed)
Steel, zinc plated, Cr(VI)-free	CF	WEE16SROMDCF	NBR
Stainless Steel	71	WEE16SRBOMD71	VIT

Adjustable locknut elbow, branch tee, run tee or 45° elbow

On customer request!

WEE Adjustable locknut elbow EO 24° cone end/Adjustable thread

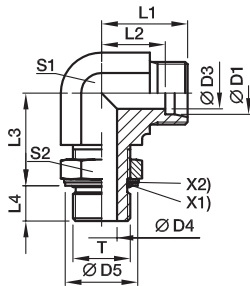

T	Order code	Surface
metric thread – O-ring + retaining ring	WEE...MOMD	CF
metric thread – O-ring (ISO 6149)	WEE...MOROMD	CF
UN/UNF thread – O-ring (ISO 11926)	WEE...UNFOMD	CF

TEE Adjustable locknut branch tee EO 24° cone end/Adjustable thread

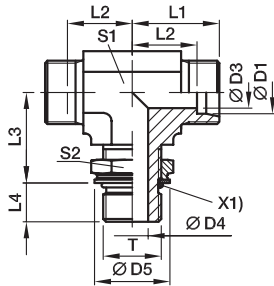

T	Order code	Surface
metric thread – O-ring + retaining ring	TEE...MOMD	CF
metric thread – O-ring (ISO 6149)	TEE...MOROMD	CF
UN/UNF thread – O-ring (ISO 11926)	TEE...UNFOMD	CF
BSPP thread – O-ring + retaining ring (ISO 1179)	TEE...ROMD	CF

LEE Adjustable locknut run tee EO 24° cone end/Adjustable thread

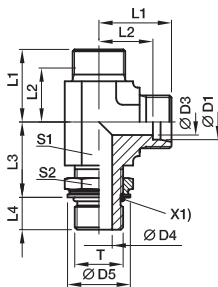

T	Order code	Surface
metric thread – O-ring + retaining ring	LEE...MOMD	CF
metric thread – O-ring (ISO 6149)	LEE...MOROMD	CF
UN/UNF thread – O-ring (ISO 11926)	LEE...UNFOMD	CF
BSPP thread – O-ring + retaining ring (ISO 1179)	LEE...ROMD	CF

VEE Adjustable locknut 45° elbow EO 24° cone end/Adjustable thread

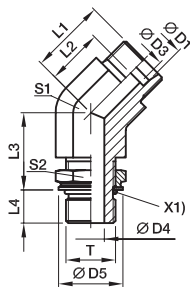

T	Order code	Surface
metric thread – O-ring + retaining ring	VEE...MOMD	CF
metric thread – O-ring (ISO 6149)	VEE...MOROMD	CF
UN/UNF thread – O-ring (ISO 11926)	VEE...UNFOMD	CF
BSPP thread – O-ring + retaining ring (ISO 1179)	VEE...ROMD	CF

WH-M-KDS High pressure banjo elbow

EO 24° cone end / Male metric thread with soft seal ring

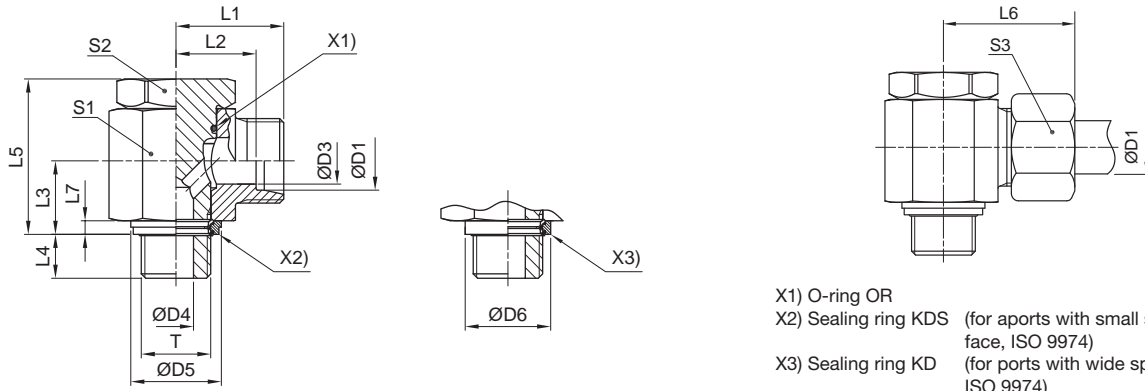

- X1) O-ring OR
- X2) Sealing ring KDS (for apertures with small spot face, ISO 9974)
- X3) Sealing ring KD (for ports with wide spot face, ISO 9974)

Series	D1	T	D3	D4	D5 KDS	D6 KD	L1	L2	L3	L4	L5	L6	L7	S1	S2	S3	Weight g/1 piece	Order code*	PN (bar) ¹⁾	
																			CF	71
L ³⁾	06	M 10×1.0	4	4.5	14.9	17.0	19.0	12.0	10.5	8	24.0	27	2.5	17	17	14	54	WH06LMKDSOMD	315	315
	08	M 12×1.5	6	6.0	17.0	22.0	21.5	14.5	14.0	12	30.0	29	3.0	22	19	17	97	WH08LMKDSOMD	315	315
	10	M 14×1.5	8	6.0	18.9	22.5	22.5	15.5	14.0	12	30.0	30	3.0	22	19	19	104	WH10LMKDSOMD	315	315
	12	M 16×1.5	10	7.5	21.9	27.0	25.0	18.0	16.5	12	36.0	33	3.0	27*	24	22	180	WH12LMKDSOMD	315	315
	15	M 18×1.5	11	9.0	23.9	29.0	27.5	21.5	18.5	12	39.5	37	3.0	30	27	27	244	WH15LMKDSOMD	315	315
	18	M 22×1.5	15	12.0	26.9	32.0	28.5	21.0	21.5	14	45.0	37	4.5	32	30	32	327	WH18LMKDSOMD	315	315
	22	M 26×1.5	19	17.0	31.9	41.0	35.0	27.5	24.0	16	53.0	44	3.5	41	36	36	573	WH22LMKDSOMD	160	160
	28	M 33×2.0	24	21.0	39.9	46.0	39.5	32.0	30.5	18	66.0	49	3.5	50	46	41	1017	WH28LMKDSOMD	160	160
	35	M 42×2.0	30	27.0	49.9	57.0	46.5	36.0	35.5	20	76.0	58	3.5	60	55	50	1512	WH35LMKDSOMD	160	160
	42	M 48×2.0	36	34.0	55.9	64.0	51.5	40.5	40.5	22	87.0	63	3.5	70	60	60	2217	WH42LMKDSOMD	160	160
S ⁴⁾	06	M 12×1.5	4	6.0	17.0	22.0	23.5	16.5	14.0	12	30.0	31	3.0	22	19	17	104	WH06SMKDSOMD	400	400
	08	M 14×1.5	5	6.0	18.9	22.5	23.5	16.5	14.0	12	30.0	31	3.0	22	19	19	110	WH08SMKDSOMD	400	400
	10	M 16×1.5	7	7.5	21.9	27.0	26.0	18.5	16.5	12	36.0	35	3.0	27	24	22	186	WH10SMKDSOMD	400	400
	12	M 18×1.5	8	9.0	23.9	29.0	27.5	20.0	18.5	12	39.5	36	3.0	27*	27	24	246	WH12SMKDSOMD	400	400
	16	M 22×1.5	12	12.0	26.9	32.0	30.5	22.0	21.5	14	45.0	40	4.5	32	30	30	327	WH16SMKDSOMD	315	315
	20	M 27×2.0	16	16.0	32.9	41.0	37.0	26.5	24.0	16	53.0	48	3.5	41	36	36	598	WH20SMKDSOMD	315	315
	25	M 33×2.0	20	21.0	39.9	46.0	43.5	31.5	30.5	18	66.0	56	3.5	50	46	46	1055	WH25SMKDSOMD	250	250
	30	M 42×2.0	25	27.0	49.9	57.0	50.5	37.0	35.5	20	76.0	64	3.5	60	55	50	1572	WH30SMKDSOMD	160	160
	38	M 48×2.0	32	34.0	55.9	64.0	57.5	41.5	40.5	22	87.0	72	3.5	70	60	60	2317	WH38SMKDSOMD	160	160

¹⁾ Pressure shown = item deliverable

³⁾ L = light series; ⁴⁾ S = heavy series

$$\frac{PN \text{ (bar)}}{10} = PN \text{ (MPa)}$$

Delivery without nut and ring. Information on ordering complete fittings or alternative sealing materials see page 17.

*S1=SW30 in 1.4571

*Please add the **suffixes** below according to the material/surface required.

Order code suffixes			
Material	Suffix surface and material	Example	Standard sealing material (no additional suffix needed)
Steel, zinc plated, Cr(VI)-free	CF	WH16SMKDSOMDCF	NBR
Stainless Steel	71	WH16SMKDOMD71	VIT/PTFE

Stainless Steel only with sealing ring **KD** available!
Replace KDS by **KD** in the order code.

WH-M High pressure banjo elbow

EO 24° cone end / Male metric thread with metal sealing ring

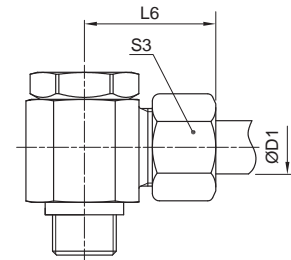
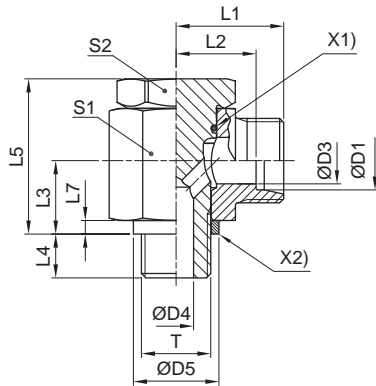

X1) O-ring OR
X2) Sealing ring DKA

Series	D1	T	D3	D4	D5	L1	L2	L3	L4	L5	L6	L7	S1	S2	S3	Weight g/1 piece	Order code*	PN (bar) ¹⁾	
																		CF	71
L ³⁾	06	M 10×1.0	4	4.5	14	19.0	12.0	10.5	8	24.0	27	2.5	17	17	14	54	WH06LMOMD	250	250
	08	M 12×1.5	6	6.0	17	21.5	14.5	14.0	12	30.0	29	3.0	22	19	17	97	WH08LMOMD	250	250
	10	M 14×1.5	8	6.0	19	22.5	15.5	14.0	12	30.0	30	3.0	22	19	19	104	WH10LMOMD	250	250
	12	M 16×1.5	10	7.5	21	25.0	18.0	16.5	12	36.0	33	3.0	27	24	22	180	WH12LMOMD	250	250
	15	M 18×1.5	11	9.0	23	27.5	21.5	18.5	12	39.5	37	3.0	30	27	27	243	WH15LMOMD	250	250
	18	M 22×1.5	15	12.0	27	28.5	21.0	21.5	14	45.0	37	4.5	32	30	32	326	WH18LMOMD	250	250
	22	M 26×1.5	19	17.0	31	35.0	27.5	24.0	16	53.0	44	3.5	41	36	36	574	WH22LMOMD	160	160
	28	M 33×2.0	24	21.0	39	39.5	32.0	30.5	18	66.0	49	3.5	50	46	41	1016	WH28LMOMD	160	160
	35	M 42×2.0	30	27.0	49	46.5	36.0	35.5	20	76.0	58	3.5	60	55	50	1512	WH35LMOMD	160	160
	42	M 48×2.0	36	34.0	55	51.5	40.5	40.5	22	87.0	63	3.5	70	60	60	2216	WH42LMOMD	160	160
S ⁴⁾	06	M 12×1.5	4	6.0	17	23.5	16.5	14.0	12	30.0	31	3.0	22	19	17	104	WH06SMOMD	315	315
	08	M 14×1.5	5	6.0	19	23.5	16.5	14.0	12	30.0	31	3.0	22	19	19	111	WH08SMOMD	315	315
	10	M 16×1.5	7	7.5	21	26.0	18.5	16.5	12	36.0	35	3.0	27	24	22	186	WH10SMOMD	315	315
	12	M 18×1.5	8	9.0	23	27.5	20.0	18.5	12	39.5	36	3.0	27*	27	24	246	WH12SMOMD	315	315
	16	M 22×1.5	12	12.0	27	30.5	22.0	21.5	14	45.0	40	4.5	32	30	30	326	WH16SMOMD	315	315
	20	M 27×2.0	16	16.0	32	37.0	26.5	24.0	16	53.0	48	3.5	41	36	36	596	WH20SMOMD	160	160
	25	M 33×2.0	20	21.0	39	43.5	31.5	30.5	18	66.0	56	3.5	50	46	46	1055	WH25SMOMD	160	160
	30	M 42×2.0	25	27.0	49	50.5	37.0	35.5	20	76.0	64	3.5	60	55	50	1572	WH30SMOMD	160	160
38	M 48×2.0	32	34.0	55	57.5	41.5	40.5	22	87.0	72	3.5	70	60	60	2316	WH38SMOMD	160	160	

¹⁾ Pressure shown = item deliverable

³⁾ L = light series; ⁴⁾ S = heavy series

$$\frac{PN \text{ (bar)}}{10} = PN \text{ (MPa)}$$

Delivery without nut and ring. Information on ordering complete fittings or alternative sealing materials see page 17.

*S1=SW30 in 1.4571

*Please add the **suffixes** below according to the material/surface required.

Order code suffixes			
Material	Suffix surface and material	Example	Standard sealing material (no additional suffix needed)
Steel, zinc plated, Cr(VI)-free	CF	WH16SMOMDCF	NBR
Stainless Steel	71	WH16SMOMD71	VIT

WH-R-KDS High pressure banjo elbow

EO 24° cone end / Male BSPP thread with soft seal ring

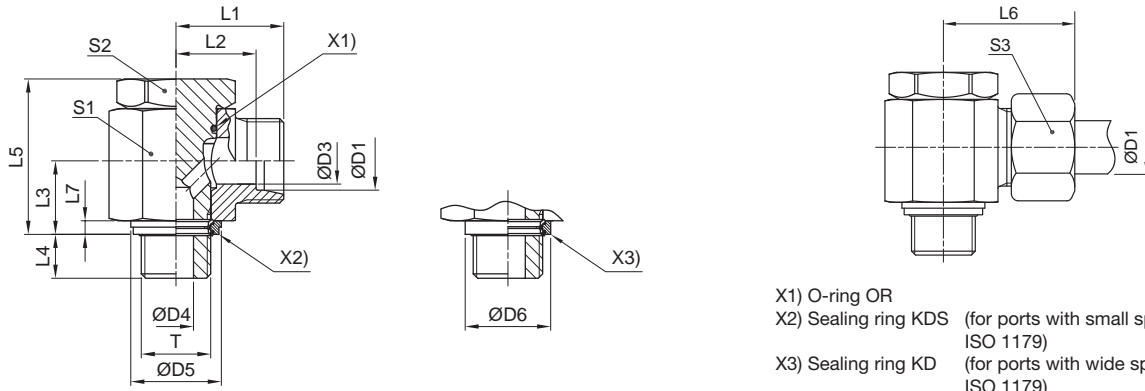

- X1) O-ring OR
 X2) Sealing ring KDS (for ports with small spot face, ISO 1179)
 X3) Sealing ring KD (for ports with wide spot face, ISO 1179)

Series	D1 T	D3	D4	D5 KDS	D6 KD	L1	L2	L3	L4	L5	L6	L7	S1	S2	S3	Weight g/1 piece	Order code*	PN (bar) ¹⁾		
																		CF	71	
L ³⁾	06	G 1/8 A	4	4.5	14.9	17	19.0	12.0	10.5	8	24	27	2.5	17	17	14	53	WH06LRKDSOMD	315	315
	08	G 1/4 A	6	6.0	18.9	22	21.5	14.5	14.0	12	30	29	3.0	22	19	17	101	WH08LRKDSOMD	315	315
	10	G 1/4 A	8	6.0	18.9	22	22.5	15.5	14.0	12	30	30	3.0	22	19	19	102	WH10LRKDSOMD	315	315
	12	G 3/8 A	10	7.5	21.9	27	25.0	18.0	16.5	12	36	33	3.0	27	24	22	181	WH12LRKDSOMD	315	315
	15	G 1/2 A	12	11.0	26.9	32	28.5	21.5	21.5	14	45	37	4.5	32	30	27	312	WH15LRKDSOMD	315	315
	18	G 1/2 A	15	11.0	26.9	32	28.5	21.0	21.5	14	45	37	4.5	32	30	32	319	WH18LRKDSOMD	315	315
	22	G 3/4 A	19	17.0	32.9	41	35.0	27.5	24.0	16	53	44	3.5	41	36	36	578	WH22LRKDSOMD	160	160
	28	G 1 A	24	21.0	39.9	46	39.5	32.0	30.5	18	66	49	3.5	50	46	41	1035	WH28LRKDSOMD	160	160
	35	G 1 1/4 A	30	27.0	49.9	57	46.5	36.0	35.5	20	76	58	3.5	60	55	50	1499	WH35LRKDSOMD	160	160
	42	G 1 1/2 A	36	34.0	55.9	64	51.5	40.5	40.5	22	87	63	3.5	70	60	60	2196	WH42LRKDSOMD	160	160
S ⁴⁾	06	G 1/4 A	4	6.0	18.9	22	23.5	16.5	14.0	12	30	31	3.0	22	19	17	107	WH06SRKDSOMD	400	400
	08	G 1/4 A	5	6.0	18.9	22	23.5	16.5	14.0	12	30	31	3.0	22	19	19	107	WH08SRKDSOMD	400	400
	10	G 3/8 A	7	7.5	21.9	27	26.0	18.5	16.5	12	36	35	3.0	27	24	22	188	WH10SRKDSOMD	400	400
	12	G 3/8 A	8	7.5	21.9	27	26.0	18.5	16.5	12	36	35	3.0	27*	24	24	190	WH12SRKDSOMD	400	400
	16	G 1/2 A	12	11.0	26.9	32	30.5	22.0	21.5	14	45	40	4.5	32	30	30	324	WH16SRKDSOMD	315	315
	20	G 3/4 A	16	17.0	32.9	41	37.0	26.5	24.0	16	53	48	3.5	41	36	36	588	WH20SRKDSOMD	315	315
	25	G 1 A	20	21.0	39.9	46	43.5	31.5	30.5	18	66	56	3.5	50	46	46	1073	WH25SRKDSOMD	250	250
	30	G 1 1/4 A	25	27.0	49.9	57	50.5	37.0	35.5	20	76	64	3.5	60	55	50	1559	WH30SRKDSOMD	160	160
38	G 1 1/2 A	32	34.0	55.9	64	57.5	41.5	40.5	22	87	72	3.5	70	60	60	2296	WH38SRKDSOMD	160	160	

¹⁾ Pressure shown = item deliverable

³⁾ L = light series; ⁴⁾ S = heavy series

$$\frac{\text{PN (bar)}}{10} = \text{PN (MPa)}$$

Delivery without nut and ring. Information on ordering complete fittings or alternative sealing materials see page 17.

*Please add the **suffixes** below according to the material/surface required.

Order code suffixes			
Material	Suffix surface and material	Example	Standard sealing material (no additional suffix needed)
Steel, zinc plated, Cr(VI)-free	CF	WH16SRKDSOMDCF	NBR
Stainless Steel	71	WH16SRKDOMD71	VIT/PTFE

Stainless Steel only with sealing ring **KD** available!
 Replace KDS by **KD** in the order code.

WH-R High pressure banjo elbow

EO 24° cone end / Male BSPP thread with metal sealing ring

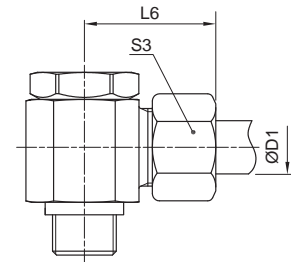
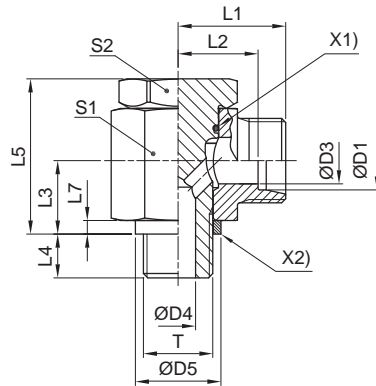

X1) O-ring OR
X2) Sealing ring DKA

Series	D1	T	D3	D4	D5	L1	L2	L3	L4	L5	L6	L7	S1	S2	S3	Weight g/1 piece	Order code*	PN (bar) ¹⁾		
																		CF	71	MS
L ³⁾	06	G 1/8 A	4	4.5	14	19.0	12.0	10.5	8	24	27	2.5	17	17	14	53	WH06LROMD	250	250	160
	08	G 1/4 A	6	6.0	18	21.5	14.5	14.0	12	30	29	3.0	22	19	17	101	WH08LROMD	250	250	160
	10	G 1/4 A	8	6.0	18	22.5	15.5	14.0	12	30	30	3.0	22	19	19	102	WH10LROMD	250	250	160
	12	G 3/8 A	10	7.5	22	25.0	18.0	16.5	12	36	33	3.0	27	24	22	181	WH12LROMD	250	250	160
	15	G 1/2 A	12	11.0	26	28.5	21.5	21.5	14	45	37	4.5	32	30	27	311	WH15LROMD	250	250	160
	18	G 1/2 A	15	11.0	26	28.5	21.0	21.5	14	45	37	4.5	32	30	32	319	WH18LROMD	250	250	160
	22	G 3/4 A	19	17.0	32	35.0	27.5	24.0	16	53	44	3.5	41	36	36	577	WH22LROMD	160	160	
	28	G 1 A	24	21.0	39	39.5	32.0	30.5	18	66	49	3.5	50	46	41	1034	WH28LROMD	160	160	
	35	G 1 1/4 A	30	27.0	57	46.5	36.0	35.5	20	76	58	3.5	60	55	50	1500	WH35LROMD	160	160	
	42	G 1 1/2 A	36	34.0	55	51.5	40.5	40.5	22	87	63	3.5	70	60	60	2195	WH42LROMD	160	160	
S ⁴⁾	06	G 1/4 A	4	6.0	18	23.5	16.5	14.0	12	30	31	3.0	22	19	17	107	WH06SROMD	315	315	200
	08	G 1/4 A	5	6.0	18	23.5	16.5	14.0	12	30	31	3.0	22	19	19	107	WH08SROMD	315	315	200
	10	G 3/8 A	7	7.5	22	26.0	18.5	16.5	12	36	35	3.0	27	24	22	188	WH10SROMD	315	315	200
	12	G 3/8 A	8	7.5	22	26.0	18.5	16.5	12	36	35	3.0	27*	24	24	190	WH12SROMD	315	315	200
	16	G 1/2 A	12	11.0	26	30.5	22.0	21.5	14	45	40	4.5	32	30	30	317	WH16SROMD	315	315	
	20	G 3/4 A	16	17.0	32	37.0	26.5	24.0	16	53	48	3.5	41	36	36	587	WH20SROMD	160	160	
	25	G 1 A	20	21.0	39	43.5	31.5	30.5	18	66	56	3.5	50	46	46	1072	WH25SROMD	160	160	
	30	G 1 1/4 A	25	27.0	49	50.5	37.0	35.5	20	76	64	3.5	60	55	50	1560	WH30SROMD	160	160	
	38	G 1 1/2 A	32	34.0	55	57.5	41.5	40.5	22	87	72	3.5	70	60	60	2295	WH38SROMD	160	160	

¹⁾ Pressure shown = item deliverable

³⁾ L = light series; ⁴⁾ S = heavy series

$$\frac{PN \text{ (bar)}}{10} = PN \text{ (MPa)}$$

Delivery without nut and ring. Information on ordering complete fittings or alternative sealing materials see page 17.

*Please add the **suffixes** below according to the material/surface required

Order code suffixes			
Material	Suffix surface and material	Example	Standard sealing material (no additional suffix needed)
Steel, zinc plated, Cr(VI)-free	CF	WH16SROMDCF	NBR
Stainless Steel	71	WH16SROMD71	VIT
Brass	MS	WH18LROMDMS	NBR

TH-M-KDS High pressure banjo tee

EO 24° cone end / Male metric thread with soft seal ring

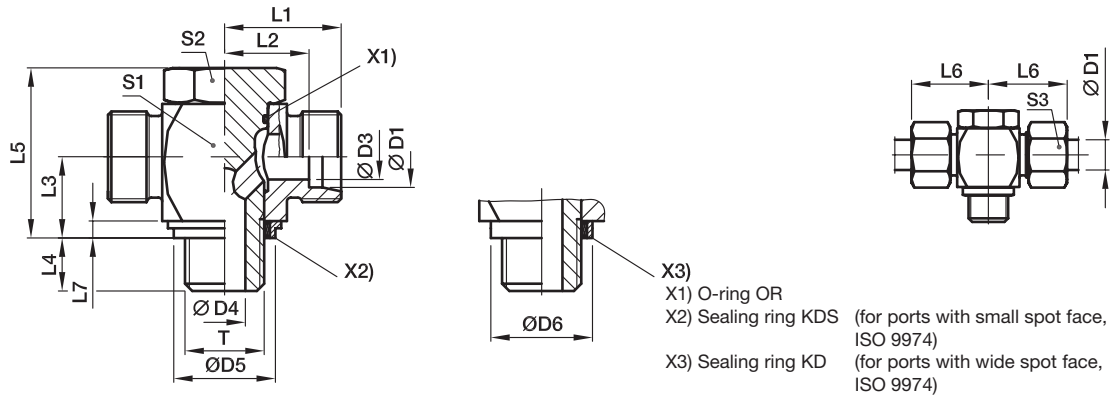

Series	D1	T	D3	D4	D5 KDS	D6 KD	L1	L2	L3	L4	L5	L6	L7	S1	S2	S3	Weight g/1 piece	Order code*	PN (bar) ¹⁾	
																			CF	71
L ³⁾	06	M 10×1.0	4	4.5	14.9	17.0	19.0	12.0	10.5	8	24.0	27	2.5	17	17	14	59	TH06LMKDSOMD	315	315
	08	M 12×1.5	6	6.0	17.0	22.0	21.5	14.5	14.0	12	30.0	29	3.0	22	19	17	104	TH08LMKDSOMD	315	315
	10	M 14×1.5	8	6.0	18.9	22.5	22.5	15.5	14.0	12	30.0	30	3.0	22	19	19	112	TH10LMKDSOMD	315	315
	12	M 16×1.5	10	7.5	21.9	27.0	25.0	18.0	16.5	12	36.0	33	3.0	27	24	22	192	TH12LMKDSOMD	315	315
	15	M 18×1.5	11	9.0	23.9	29.0	27.5	21.5	18.5	12	39.5	37	3.0	30	27	27	258	TH15LMKDSOMD	315	315
	18	M 22×1.5	15	12.0	26.9	32.0	28.5	21.0	21.5	14	45.0	37	4.5	32	30	32	337	TH18LMKDSOMD	315	315
	22	M 26×1.5	19	17.0	31.9	41.0	35.0	27.5	24.0	16	53.0	44	3.5	41	36	36	589	TH22LMKDSOMD	160	160
	28	M 33×2.0	24	21.0	39.9	46.0	39.5	32.0	30.5	18	66.0	49	3.5	50	46	41	1072	TH28LMKDSOMD	160	160
	35	M 42×2.0	30	27.0	49.9	57.0	46.5	36.0	35.5	20	76.0	58	3.5	60	55	50	1778	TH35LMKDSOMD	160	160
	42	M 48×2.0	36	34.0	55.9	64.0	51.5	40.5	40.5	22	87.0	63	3.5	70	60	60	2566	TH42LMKDSOMD	160	160
S ⁴⁾	06	M 12×1.5	4	6.0	17.0	22.0	23.5	16.5	14.0	12	30.0	31	3.0	22	19	17	112	TH06SMKDSOMD	400	400
	08	M 14×1.5	5	6.0	18.9	22.5	23.5	16.5	14.0	12	30.0	31	3.0	22	19	19	123	TH08SMKDSOMD	400	400
	10	M 16×1.5	7	7.5	21.9	27.0	26.0	18.5	16.5	12	36.0	35	3.0	27	24	22	200	TH10SMKDSOMD	400	400
	12	M 18×1.5	8	9.0	23.9	29.0	27.5	20.0	18.5	12	39.5	36	3.0	27	27	24	261	TH12SMKDSOMD	400	400
	16	M 22×1.5	12	12.0	26.9	32.0	30.5	22.0	21.5	14	45.0	40	4.5	32	30	30	351	TH16SMKDSOMD	315	315
	20	M 27×2.0	16	16.0	32.9	41.0	37.0	26.5	24.0	16	53.0	48	3.5	41	36	36	629	TH20SMKDSOMD	315	315
	25	M 33×2.0	20	21.0	39.9	46.0	43.5	31.5	30.5	18	66.0	56	3.5	50	46	46	1106	TH25SMKDSOMD	250	250
	30	M 42×2.0	25	27.0	49.9	57.0	50.5	37.0	35.5	20	76.0	64	3.5	60	55	50	1843	TH30SMKDSOMD	160	160
	38	M 48×2.0	32	34.0	55.9	64.0	57.5	41.5	40.5	22	87.0	72	3.5	70	60	60	2744	TH38SMKDSOMD	160	160

¹⁾ Pressure shown = item deliverable

³⁾ L = light series; ⁴⁾ S = heavy series

$$\frac{PN \text{ (bar)}}{10} = PN \text{ (MPa)}$$

Delivery without nut and ring. Information on ordering complete fittings or alternative sealing materials see page 17.

*S1=SW30 in 1.4571

*Please add the **suffixes** below according to the material/surface required.

Order code suffixes			
Material	Suffix surface and material	Example	Standard sealing material (no additional suffix needed)
Steel, zinc plated, Cr(VI)-free	CF	TH16SMKDSOMDCF	NBR
Stainless Steel	71	TH16SMKDOMD71	VIT/PTFE

Stainless Steel only with sealing ring KD available!
 Replace KDS by KD in the order code.

TH-M High pressure banjo tee

EO 24° cone end / Male metric thread with metal sealing ring

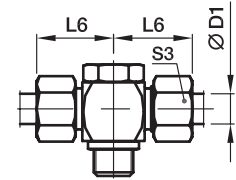
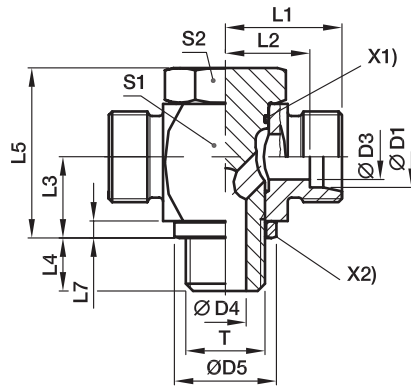

X1) O-ring OR
X2) Sealing ring DKA

Series	D1	T	D3	D4	D5	L1	L2	L3	L4	L5	L6	L7	S1	S2	S3	Weight g/1 piece	Order code*	PN (bar) ¹⁾	
																		CF	71
L ³⁾	06	M 10×1.0	4	4.5	14	19.0	12.0	10.5	8	24.0	27	2.5	17	17	14	58	TH06LMOMD	250	250
	08	M 12×1.5	6	6.0	17	21.5	14.5	14.0	12	30.0	29	3.0	22	19	17	104	TH08LMOMD	250	250
	10	M 14×1.5	8	6.0	19	22.5	15.5	14.0	12	30.0	30	3.0	22	19	19	112	TH10LMOMD	250	250
	12	M 16×1.5	10	7.5	21	25.0	18.0	16.5	12	36.0	33	3.0	27	24	22	191	TH12LMOMD	250	250
	15	M 18×1.5	11	9.0	23	27.5	21.5	18.5	12	39.5	37	3.0	30	27	27	258	TH15LMOMD	250	250
	18	M 22×1.5	15	12.0	27	28.5	21.0	21.5	14	45.0	37	4.5	32	30	32	337	TH18LMOMD	250	250
	22	M 26×1.5	19	17.0	31	35.0	27.5	24.0	16	53.0	44	3.5	41	36	36	590	TH22LMOMD	160	160
	28	M 33×2.0	24	21.0	39	39.5	32.0	30.5	18	66.0	49	3.5	50	46	41	1072	TH28LMOMD	160	160
	35	M 42×2.0	30	27.0	49	46.5	36.0	35.5	20	76.0	58	3.5	60	55	50	1778	TH35LMOMD	160	160
	42	M 48×2.0	36	34.0	55	51.5	40.5	40.5	22	87.0	63	3.5	70	60	60	2565	TH42LMOMD	160	160
S ⁴⁾	06	M 12×1.5	4	6.0	17	23.5	16.5	14.0	12	30.0	31	3.0	22	19	17	112	TH06SMOMD	315	315
	08	M 14×1.5	5	6.0	19	23.5	16.5	14.0	12	30.0	31	3.0	22	19	19	124	TH08SMOMD	315	315
	10	M 16×1.5	7	7.5	21	26.0	18.5	16.5	12	36.0	35	3.0	27	24	22	200	TH10SMOMD	315	315
	12	M 18×1.5	8	9.0	23	27.5	20.0	18.5	12	39.5	36	3.0	27	27	24	261	TH12SMOMD	315	315
	16	M 22×1.5	12	12.0	27	30.5	22.0	21.5	14	45.0	40	4.5	32	30	30	350	TH16SMOMD	315	315
	20	M 27×2.0	16	16.0	32	37.0	26.5	24.0	16	53.0	48	3.5	41	36	36	628	TH20SMOMD	160	160
	25	M 33×2.0	20	21.0	39	43.5	31.5	30.5	18	66.0	56	3.5	50	46	46	1106	TH25SMOMD	160	
	30	M 42×2.0	25	27.0	49	50.5	37.0	35.5	20	76.0	64	3.5	60	55	50	1843	TH30SMOMD	160	160
38	M 48×2.0	32	34.0	55	57.5	41.5	40.5	22	87.0	72	3.5	70	60	60	2741	TH38SMOMD	160	160	

¹⁾ Pressure shown = item deliverable

³⁾ L = light series; ⁴⁾ S = heavy series

$\frac{PN (bar)}{10} = PN (MPa)$

Delivery without nut and ring. Information on ordering complete fittings or alternative sealing materials see page 17.

*S1=SW30 in 1.4571

*Please add the **suffixes** below according to the material/surface required.

Order code suffixes			
Material	Suffix surface and material	Example	Standard sealing material (no additional suffix needed)
Steel, zinc plated, Cr(VI)-free	CF	TH16SMOMDCF	NBR
Stainless Steel	71	TH16SMOMD71	VIT

TH-R-KDS High pressure banjo tee

EO 24° cone end / Male BSPP thread with soft seal ring

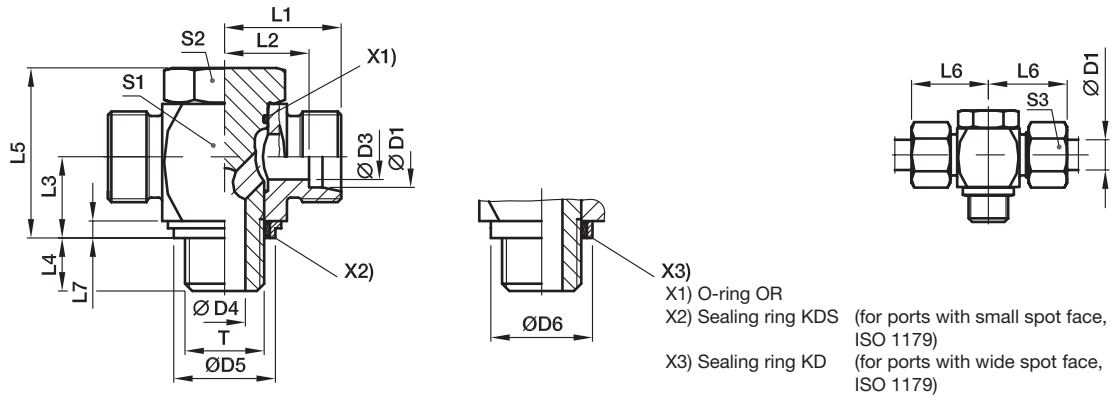

Series	D1	T	D3	D4	D5 KDS	D6 KD	L1	L2	L3	L4	L5	L6	L7	S1	S2	S3	Weight g/1 piece	Order code*	PN (bar) ¹⁾	
																			CF	71
L ³⁾	06	G 1/8 A	4	4.5	14.9	17	19.0	12.0	10.5	8	24	27	2.5	17	17	14	58	TH06LRKDSOMD	315	315
	08	G 1/4 A	6	6.0	18.9	22	21.5	14.5	14.0	12	30	29	3.0	22	19	17	108	TH08LRKDSOMD	315	315
	10	G 1/4 A	8	6.0	18.9	22	22.5	15.5	14.0	12	30	30	3.0	22	19	19	110	TH10LRKDSOMD	315	315
	12	G 3/8 A	10	7.5	21.9	27	25.0	18.0	16.5	12	36	33	3.0	27	24	22	193	TH12LRKDSOMD	315	315
	15	G 1/2 A	12	11.0	26.9	32	28.5	21.5	21.5	14	45	37	4.5	32	30	27	321	TH15LRKDSOMD	315	315
	18	G 1/2 A	15	11.0	26.9	32	28.5	21.0	21.5	14	45	37	4.5	32	30	32	329	TH18LRKDSOMD	315	315
	22	G 3/4 A	19	17.0	32.9	41	35.0	27.5	24.0	16	53	44	3.5	41	36	36	585	TH22LRKDSOMD	160	160
	28	G 1 A	24	21.0	39.9	46	39.5	32.0	30.5	18	66	49	3.5	50	46	41	1090	TH28LRKDSOMD	160	160
	35	G 1 1/4 A	30	27.0	49.9	57	46.5	36.0	35.5	20	76	58	3.5	60	55	50	1765	TH35LRKDSOMD	160	160
	42	G 1 1/2 A	36	34.0	55.9	64	51.5	40.5	40.5	22	87	63	3.5	70	60	60	2545	TH42LRKDSOMD	160	160
S ⁴⁾	06	G 1/4 A	4	6.0	18.9	22	23.5	16.5	14.0	12	30	31	3.0	22	19	17	116	TH06SRKDSOMD	400	400
	08	G 1/4 A	5	6.0	18.9	22	23.5	16.5	14.0	12	30	31	3.0	22	19	19	121	TH08SRKDSOMD	400	400
	10	G 3/8 A	7	7.5	21.9	27	26.0	18.5	16.5	12	36	35	3.0	27	24	22	201	TH10SRKDSOMD	400	400
	12	G 3/8 A	8	7.5	21.9	27	26.0	18.5	16.5	12	36	35	3.0	27	24	24	207	TH12SRKDSOMD	400	400
	16	G 1/2 A	12	11.0	26.9	32	30.5	22.0	21.5	14	45	40	4.5	32	30	30	350	TH16SRKDSOMD	315	315
	20	G 3/4 A	16	17.0	32.9	41	37.0	26.5	24.0	16	53	48	3.5	41	36	36	620	TH20SRKDSOMD	315	315
	25	G 1 A	20	21.0	39.9	46	43.5	31.5	30.5	18	66	56	3.5	50	46	46	1124	TH25SRKDSOMD	250	250
	30	G 1 1/4 A	25	27.0	49.9	57	50.5	37.0	35.5	20	76	64	3.5	60	55	50	1830	TH30SRKDSOMD	160	160
38	G 1 1/2 A	32	34.0	55.9	64	57.5	41.5	40.5	22	87	72	3.5	70	60	60	2721	TH38SRKDSOMD	160	160	

¹⁾ Pressure shown = item deliverable

³⁾ L = light series; ⁴⁾ S = heavy series

$\frac{\text{PN (bar)}}{10} = \text{PN (MPa)}$

Delivery without nut and ring. Information on ordering complete fittings or alternative sealing materials see page 17.

*Please add the **suffixes** below according to the material/surface required.

Order code suffixes			
Material	Suffix surface and material	Example	Standard sealing material (no additional suffix needed)
Steel, zinc plated, Cr(VI)-free	CF	TH16SRKDSOMDCF	NBR
Stainless Steel	71	TH16SRKD0MD71	VIT/PTFE

Stainless Steel only with sealing ring **KD** available!
Replace KDS by **KD** in the order code.

TH-R High pressure banjo tee

EO 24° cone end / Male BSPP thread with metal sealing ring

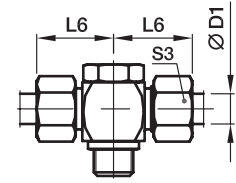
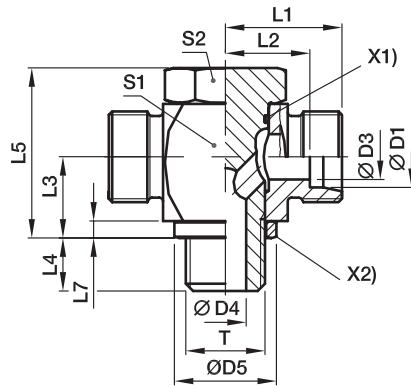

X1) O-ring OR
X2) Sealing ring DKA

Series	D1	T	D3	D4	D5	L1	L2	L3	L4	L5	L6	L7	S1	S2	S3	Weight g/1 piece	Order code*	PN (bar) ¹⁾	
																		CF	71
L ³⁾	06	G 1/8 A	4	4.5	14	19.0	12.0	10.5	8	24	27	2.5	17	17	14	58	TH06LROMD	250	250
	08	G 1/4 A	6	6.0	18	21.5	14.5	14.0	12	30	29	3.0	22	19	17	108	TH08LROMD	250	250
	10	G 1/4 A	8	6.0	18	22.5	15.5	14.0	12	30	30	3.0	22	19	19	110	TH10LROMD	250	250
	12	G 3/8 A	10	7.5	22	25.0	18.0	16.5	12	36	33	3.0	27	24	22	193	TH12LROMD	250	250
	15	G 1/2 A	12	11.0	26	28.5	21.5	21.5	14	45	37	4.5	32	30	27	321	TH15LROMD	250	250
	18	G 1/2 A	15	11.0	26	28.5	21.0	21.5	14	45	37	4.5	32	30	32	329	TH18LROMD	250	250
	22	G 3/4 A	19	17.0	32	35.0	27.5	24.0	16	53	44	3.5	41	36	36	584	TH22LROMD	160	160
	28	G 1 A	24	21.0	39	39.5	32.0	30.5	18	66	49	3.5	50	46	41	1090	TH28LROMD	160	160
	35	G 1 1/4 A	30	27.0	57	46.5	36.0	35.5	20	76	58	3.5	60	55	50	1766	TH35LROMD	160	160
	42	G 1 1/2 A	36	34.0	55	51.5	40.5	40.5	22	87	63	3.5	70	60	60	2544	TH42LROMD	160	160
S ⁴⁾	06	G 1/4 A	4	6.0	18	23.5	16.5	14.0	12	30	31	3.0	22	19	17	116	TH06SROMD	315	315
	08	G 1/4 A	5	6.0	18	23.5	16.5	14.0	12	30	31	3.0	22	19	19	121	TH08SROMD	315	315
	10	G 3/8 A	7	7.5	22	26.0	18.5	16.5	12	36	35	3.0	27	24	22	201	TH10SROMD	315	315
	12	G 3/8 A	8	7.5	22	26.0	18.5	16.5	12	36	35	3.0	27	24	24	207	TH12SROMD	315	315
	16	G 1/2 A	12	11.0	26	30.5	22.0	21.5	14	45	40	4.5	32	30	30	350	TH16SROMD	315	315
	20	G 3/4 A	16	17.0	32	37.0	26.5	24.0	16	53	48	3.5	41	36	36	618	TH20SROMD	160	160
	25	G 1 A	20	21.0	39	43.5	31.5	30.5	18	66	56	3.5	50	46	46	1124	TH25SROMD	160	160
	30	G 1 1/4 A	25	27.0	49	50.5	37.0	35.5	20	76	64	3.5	60	55	50	1831	TH30SROMD	160	160
38	G 1 1/2 A	32	34.0	55	57.5	41.5	40.5	22	87	72	3.5	70	60	60	2720	TH38SROMD	160	160	

¹⁾ Pressure shown = item deliverable

³⁾ L = light series; ⁴⁾ S = heavy series

$$\frac{\text{PN (bar)}}{10} = \text{PN (MPa)}$$

Delivery without nut and ring. Information on ordering complete fittings or alternative sealing materials see page 17.

*Please add the **suffixes** below according to the material/surface required.

Order code suffixes			
Material	Suffix surface and material	Example	Standard sealing material (no additional suffix needed)
Steel, zinc plated, Cr(VI)-free	CF	TH16SROMDCF	NBR
Stainless Steel	71	TH16SROMD71	VIT

SWVE Metric male stud banjo elbow

SWVE-M EO 24° cone end / Metric male stud with metal seal ring

SWVE-M-KDS EO 24° cone end / Metric male stud with soft seal ring

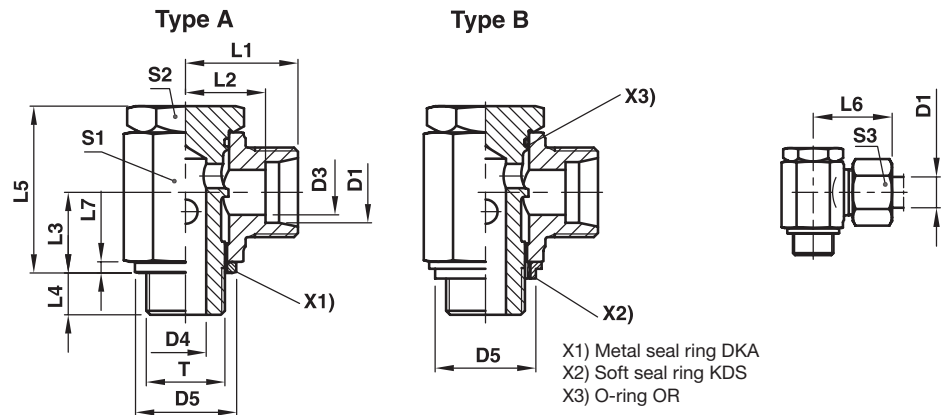

Series	D1	T	D3	D4	DKA D5	KDS D5	L1	L2	L3	L4	L5	L6	L7	S1	S2	S3	Weight g/1 piece	Type A Order code* metal sealed	Type B Order code* soft sealed	PN (bar) ¹⁾ CF
LL ²⁾	04	M 08×1.0	3.0	3.0	12.5		14.5	10.5	8.0	6	17.0	20	2.5	12	12	10	18	SWVE04LLMOMD	—	63
	06	M 10×1.0	4.5	5.0	14.0	15	15.5	10.0	10.0	6	21.0	22	2.5	14	14	12	29	SWVE06LLMOMD	SWVE06LLMKDSOMD	63
	08	M 10×1.0	6.0	5.0	14.0	15	16.5	11.0	10.0	6	21.0	23	2.5	14	14	14	31	SWVE08LLMOMD	SWVE08LLMKDSOMD	63
L ³⁾	06	M 10×1.0	4.5	5.0	14.0	15	15.5	10.5	10.0	6	21.5	25	2.5	14	14	14	31	SWVE06LMOMD	SWVE06LMKDSOMD	160
	08	M 12×1.5	6.0	6.0	17.0	17	19.0	12.0	12.0	9	25.0	27	3.0	17	17	17	51	SWVE08LMOMD	SWVE08LMKDSOMD	160
	10	M 14×1.5	8.0	6.5	19.0	19	21.0	14.0	13.0	9	27.0	29	3.0	19	19	19	68	SWVE10LMOMD	SWVE10LMKDSOMD	160
	12	M 16×1.5	10.0	8.5	21.0	22	22.5	15.5	15.0	9	32.0	30	3.0	22	21	22	100	SWVE12LMOMD	SWVE12LMKDSOMD	100
	15	M 18×1.5	12.0	11.0	23.0	24	24.5	17.5	18.0	9	37.5	33	3.0	24	24	27	138	SWVE15LMOMD	SWVE15LMKDSOMD	100
	18	M 22×1.5	15.0	13.0	27.0	27	28.0	20.5	21.5	11	44.5	37	4.5	30	27	32	241	SWVE18LMOMD	SWVE18LMKDSOMD	100
	22	M 26×1.5	19.0	18.0	31.0	32	33.0	25.5	24.0	13	49.0	42	3.5	36	32	36	351	SWVE22LMOMD	SWVE22LMKDSOMD	100
	28	M 33×2.0	24.0	22.0	39.0	40	39.5	32.0	30.5	14	66.5	49	3.5	50	46	41		SWVE28LMOMD	SWVE28LMKDSOMD	100
	35	M 42×2.0	30.0	29.0	49.0	50	46.5	36.0	35.5	16	76.0	58	3.5	60	55	50		SWVE35LMOMD	SWVE35LMKDSOMD	100
	42	M 48×2.0	36.0	35.0	55.0	56	51.5	40.5	40.5	18	86.0	63	3.5	70	60	60		SWVE42LMOMD	SWVE42LMKDSOMD	100
S ⁴⁾	06	M 12×1.5	4.0	6.0	17.0	17	21.0	14.0	12.0	9	25.0	29	3.0	17	17	17	55	SWVE06SMOMD	SWVE06SMKDSOMD	160
	08	M 14×1.5	5.0	6.5	19.0	19	22.0	15.0	13.0	9	27.0	30	3.0	19	19	19	75	SWVE08SMOMD	SWVE08SMKDSOMD	160
	10	M 16×1.5	7.0	8.5	21.0	22	23.5	16.0	15.0	9	32.0	32	3.0	22	22	22	106	SWVE10SMOMD	SWVE10SMKDSOMD	100
	12	M 18×1.5	8.0	11.0	23.0	24	24.5	17.0	18.0	9	37.0	33	3.0	24	24	24	134	SWVE12SMOMD	SWVE12SMKDSOMD	100
	16	M 22×1.5	12.0	13.0	27.0	27	30.0	21.5	21.5	11	44.5	40	4.5	30	27	30	252	SWVE16SMOMD	SWVE16SMKDSOMD	100
	20	M 27×2.0	16.0	18.0	32.0	33	35.0	24.5	24.0	13	49.0	46	3.5	36	32	36	363	SWVE20SMOMD	SWVE20SMKDSOMD	100
	25	M 33×2.0	20.0	22.0	39.0	40	43.5	31.5	30.5	14	66.5	56	3.5	50	46	46		SWVE25SMOMD	SWVE25SMKDSOMD	100
	30	M 42×2.0	25.0	29.0	49.0	50	50.5	37.0	35.5	16	76.0	64	3.5	60	55	50		SWVE30SMOMD	SWVE30SMKDSOMD	100
38	M 48×2.0	32.0	35.0	55.0	56	57.5	41.5	40.5	18	86.0	72	3.5	70	60	60		SWVE38SMOMD	SWVE38SMKDSOMD	100	

¹⁾ Pressure shown = item deliverable

²⁾ LL = very light series; ³⁾ L = light series; ⁴⁾ S = heavy series

$\frac{PN \text{ (bar)}}{10} = PN \text{ (MPa)}$

Delivery without nut and ring. Information on ordering complete fittings or alternative sealing materials see page 17.

*Please add the **suffixes** below according to the material/surface required.

Order code suffixes			
Material	Suffix surface and material	Example	Standard sealing material (no additional suffix needed)
Steel, zinc plated, Cr(VI)-free	CF	SWVE16SMOMDCF	NBR
Steel, zinc plated, Cr(VI)-free	CF	SWVE16SMKDSOMDCF	NBR

SWVE BSPP male stud banjo elbow

SWVE-R EO 24° cone end / BSPP male stud with metal seal ring

SWVE-R-KDS EO 24° cone end / BSPP male stud with soft seal ring

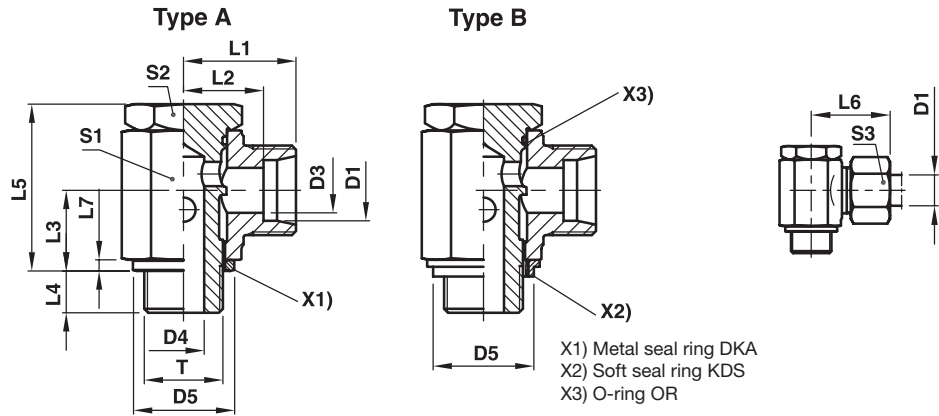

Series	D1	T	D3	D4	DKA D5	KDS D5	L1	L2	L3	L4	L5	L6	L7	S1	S2	S3	Weight g/1 piece	Type A Order code* metal sealed	Type B Order code* soft sealed	PN (bar) ¹⁾ CF
LL ²⁾	04	G 1/8 A	3.0	5.0	14	15	15.5	11.5	10.0	6	21.0	21	2.5	14	14	10	28	SWVE04LLROMD	SWVE04LLRKDSOMD	63
	06	G 1/8 A	4.5	5.0	14	15	15.5	10.0	10.0	6	21.5	22	2.5	14	14	12	28	SWVE06LLROMD	SWVE06LLRKDSOMD	63
	08	G 1/8 A	6.0	5.0	14	15	16.5	11.0	10.0	6	21.0	23	2.5	14	14	14	30	SWVE08LLROMD	SWVE08LLRKDSOMD	63
L ³⁾	06	G 1/8 A	4.0	5.0	14	15	17.5	10.5	10.0	6	21.0	25	2.5	14	14	14	31	SWVE06LROMD	SWVE06LRKDSOMD	160
	08	G 1/4 A	6.0	6.5	18	19	20.0	13.0	13.0	9	27.0	28	3.0	19	19	17	65	SWVE08LROMD	SWVE08LRKDSOMD	160
	10	G 1/4 A	8.0	6.5	18	19	21.0	14.0	13.0	9	27.0	29	3.0	19	19	19	66	SWVE10LROMD	SWVE10LRKDSOMD	160
	12	G 3/8 A	10.0	8.5	22	22	22.5	15.5	15.0	9	32.0	30	3.0	22	22	22	102	SWVE12LROMD	SWVE12LRKDSOMD	100
	15	G 1/2 A	12.0	11.0	26	27	26.0	19.0	18.0	11	37.5	34	4.5	27	27	27	171	SWVE15LROMD	SWVE15LRKDSOMD	100
	18	G 1/2 A	15.0	13.0	26	27	28.0	20.5	21.5	11	44.5	37	4.5	30	27	32	249	SWVE18LROMD	SWVE18LRKDSOMD	100
	22	G 3/4 A	19.0	18.0	32	33	33.0	25.5	24.0	13	49.0	42	3.5	36	32	36	349	SWVE22LROMD	SWVE22LRKDSOMD	100
	28	G 1 A	24.0	22.0	39	40	39.5	32.0	30.5	14	66.5	49	3.5	50	46	41		SWVE28LROMD	SWVE28LRKDSOMD	100
	35	G 1 1/4 A	30.0	29.0	49	50	46.5	36.0	35.5	16	76.0	58	3.5	60	55	50		SWVE35LROMD	SWVE35LRKDSOMD	100
	42	G 1 1/2 A	36.0	35.0	55	56	51.5	40.5	40.5	18	86.0	63	3.5	70	60	60		SWVE42LROMD	SWVE42LRKDSOMD	100
S ⁴⁾	06	G 1/4 A	4.0	6.5	18	19	22.0	15.0	13.0	9	27.0	30	3.0	19	19	17	69	SWVE06SROMD	SWVE06SRKDSOMD	160
	08	G 1/4 A	5.0	6.5	18	19	22.0	15.0	13.0	9	27.0	30	3.0	19	19	19	73	SWVE08SROMD	SWVE08SRKDSOMD	160
	10	G 3/8 A	7.0	8.5	22	22	23.5	16.0	15.0	9	32.0	32	3.0	22	22	22	108	SWVE10SROMD	SWVE10SRKDSOMD	100
	12	G 3/8 A	8.0	8.0	22	22	24.5	17.0	18.0	9	37.0	33	3.0	24	24	24	147	SWVE12SROMD	SWVE12SRKDSOMD	100
	16	G 1/2 A	12.0	13.0	26	27	30.0	21.5	21.5	11	44.5	40	4.5	30	27	30	249	SWVE16SROMD	SWVE16SRKDSOMD	100
	20	G 3/4 A	16.0	18.0	32	33	35.0	24.5	24.0	13	49.0	46	3.5	36	32	36	359	SWVE20SROMD	SWVE20SRKDSOMD	100
	25	G 1 A	20.0	22.0	39	40	43.5	31.5	30.5	14	66.5	56	3.5	50	46	46		SWVE25SROMD	SWVE25SRKDSOMD	100
	30	G 1 1/4 A	25.0	29.0	49	50	50.5	37.0	35.5	16	76.0	64	3.5	60	55	50		SWVE30SROMD	SWVE30SRKDSOMD	100
38	G 1 1/2 A	32.0	35.0	55	56	57.5	41.5	40.5	18	86.0	72	3.5	70	60	60		SWVE38SROMD	SWVE38SRKDSOMD	100	

¹⁾ Pressure shown = item deliverable

²⁾ LL = very light series; ³⁾ L = light series; ⁴⁾ S = heavy series

$$\frac{\text{PN (bar)}}{10} = \text{PN (MPa)}$$

Delivery without nut and ring. Information on ordering complete fittings see page I7.

*Please add the **suffixes** below according to the material/surface required.

Order code suffixes			
Material	Suffix surface and material	Example	Standard sealing material (no additional suffix needed)
Steel, zinc plated, Cr(VI)-free	CF	SWVE16SROMDCF	NBR
Steel, zinc plated, Cr(VI)-free	CF	SWVE16SRKDSOMDCF	NBR

WE-NPT Male stud elbow

EO 24° cone end / Male NPT thread (SAE J476)

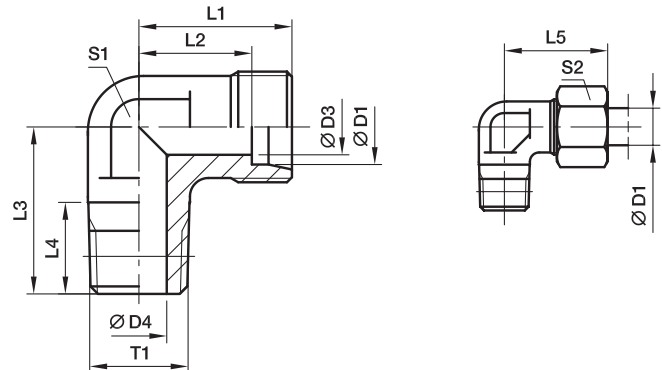

Series	D1	T1	D3	D4	L1	L2	L3	L4	L5	S1	S2	Weight g/1 piece	Order code*	PN (bar) ¹⁾		
														CF	71	MS
LL ²⁾	04	1/8-27 NPT	3.0	4.0	15	11.0	17	10.0	21	9	10	18	WE04LL1/8NPT	100		
	06	1/8-27 NPT	4.5	4.5	15	9.5	17	10.0	21	9	12	17	WE06LL1/8NPT	100		
	08	1/8-27 NPT	6.0	5.0	17	11.5	20	10.0	23	12	14	25	WE08LL1/8NPT	100		
L ³⁾	06	1/8-27 NPT	4.0	4.0	19	12.0	20	10.0	27	12	14	29	WE06L1/8NPT	315	315	200
	06	1/4-18 NPT	4.0	7.0	21	14.0	26	14.5	29	12	14	44	WE06L1/4NPT	315	315	200
	06	3/8-18 NPT	4.0	8.0	25	18.0	28	14.5	33	17	14	55	WE06L3/8NPT	315	315	200
	08	1/8-27 NPT	6.0	4.0	21	14.0	26	10.0	29	12	17	48	WE08L1/8NPT	315	315	200
	08	1/4-18 NPT	6.0	6.0	21	14.0	26	14.5	29	12	17	47	WE08L1/4NPT	315	315	200
	10	1/4-18 NPT	8.0	7.0	22	15.0	27	14.5	30	14	19	61	WE10L1/4NPT	315	315	200
	10	3/8-18 NPT	8.0	8.0	24	17.0	28	14.5	32	17	19	92	WE10L3/8NPT	315	315	200
	12	1/4-18 NPT	10.0	7.0	24	17.0	28	14.5	32	17	22	82	WE12L1/4NPT	315	315	200
	12	3/8-18 NPT	10.0	8.0	24	17.0	28	14.5	32	17	22	92	WE12L3/8NPT	315	315	200
	12	1/2-14 NPT	10.0	11.0	28	21.0	34	19.5	36	19	22	90	WE12L1/2NPT	315	315	200
	15	1/2-14 NPT	12.0	11.0	28	21.0	34	19.5	36	19	27	89	WE15L1/2NPT	315	315	200
	18	1/2-14 NPT	15.0	12.0	31	23.5	36	19.5	40	24	32	150	WE18L1/2NPT	315	315	200
	22	3/4-14 NPT	19.0	16.0	35	27.5	42	19.5	44	27	36	176	WE22L3/4NPT	160	160	100
	28	1-11.5 NPT	24.0	21.0	38	30.5	48	24.5	47	36	41	314	WE28L1NPT	160	160	100
	35	1 1/4-11.5 NPT	30.0	28.0	45	34.5	54	25.0	56	41	50	465	WE35L11/4NPT	160	160	100
42	1 1/2-11.5 NPT	36.0	34.0	51	40.0	61	26.0	63	50	60	849	WE42L11/2NPT	160	160	100	
S ⁴⁾	06	1/4-18 NPT	4.0	4.0	23	16.0	26	14.5	31	12	17	56	WE06S1/4NPT	630	630	400
	08	1/4-18 NPT	5.0	5.0	24	17.0	27	14.5	32	14	19	73	WE08S1/4NPT	630	630	400
	08	3/8-18 NPT	5.0	8.0	25	18.0	28	14.5	33	17	19	77	WE08S3/8NPT	630	630	400
	08	1/2-14 NPT	5.0	10.0	30	23.0	34	19.5	38	19	19	75	WE08S1/2NPT	630	630	400
	10	1/4-18 NPT	7.0	5.0	25	17.5	28	14.5	34	17	22	96	WE10S1/4NPT	630	630	400
	10	3/8-18 NPT	7.0	7.0	25	17.5	28	14.5	34	17	22	98	WE10S3/8NPT	630	630	400
	12	1/4-18 NPT	8.0	5.0	29	21.5	29	14.5	38	17	24	73	WE12S1/4NPT	630	630	400
	12	3/8-18 NPT	8.0	8.0	29	22.5	28	14.5	38	17	24	123	WE12S3/8NPT	630	630	400
	12	1/2-14 NPT	8.0	10.0	30	22.5	34	19.5	39	19	24	107	WE12S1/2NPT	630	630	400
	16	1/2-14 NPT	12.0	12.0	33	24.5	36	19.5	43	24	30	157	WE16S1/2NPT	400	400	250
	20	3/4-14 NPT	16.0	16.0	37	26.5	42	19.5	48	27	36	205	WE20S3/4NPT	400	400	250
	25	1-11.5 NPT	20.0	20.0	42	30.0	48	24.5	54	36	46	381	WE25S1NPT	400	400	250
	30	1 1/4-11.5 NPT	25.0	25.0	49	35.5	54	25.0	62	41	50	598	WE30S11/4NPT	400	400	250
	38	1 1/2-11.5 NPT	32.0	32.0	57	41.0	61	26.0	72	50	60	1029	WE38S11/2NPT	315	315	200

¹⁾ Pressure shown = item deliverable

²⁾ LL = very light series; ³⁾ L = light series; ⁴⁾ S = heavy series

$\frac{\text{PN (bar)}}{10} = \text{PN (MPa)}$

Delivery without nut and ring. Information on ordering complete fittings see page 17.

*Please add the **suffixes** below according to the material/surface required.

Order code suffixes		
Material	Suffix surface and material	Example
Steel, zinc plated, Cr(VI)-free	CFX	WE16S1/2NPTCFX
Stainless Steel	71X	WE16S1/2NPT71X
Brass	MSX	WE16S1/2NPTMSX

WE-M(KEG) Male stud elbow

EO 24° cone end / Male metric taper thread (DIN 3852-1, type C)

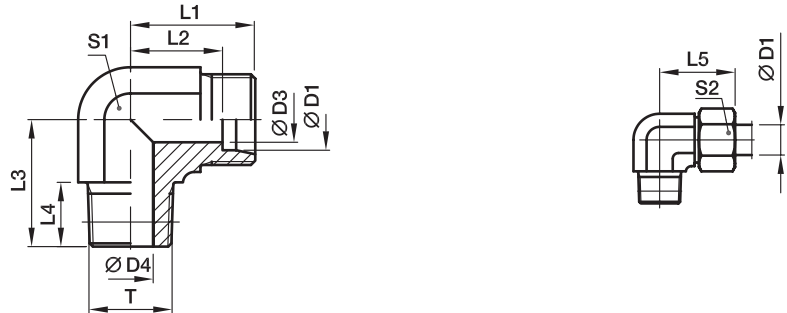

Series	D1 	T	D3	D4	L1	L2	L3	L4	L5	S1	S2	Weight g/1 piece	Order code*	PN (bar) ¹⁾		
														CF	71	MS
LL ²⁾	04	M 08×1.0 tap.	3.0	3.5	15	11.0	17	8	21	9	10	14	WE04LLM	100	100	63
	06	M 10×1.0 tap.	4.5	4.5	15	9.5	17	8	21	9	12	17	WE06LLM	100	100	63
	08	M 10×1.0 tap.	6.0	6.0	17	11.5	20	8	23	12	14	25	WE08LLM	100	100	63
L ³⁾	06	M 10×1.0 tap.	4.0	4.0	19	12.0	20	8	27	12	14	29	WE06LM	315	315	200
	08	M 12×1.5 tap.	6.0	6.0	21	14.0	26	12	29	12	17	46	WE08LM	315	315	200
	10	M 14×1.5 tap.	8.0	7.0	22	15.0	27	12	30	14	19	62	WE10LM	315	315	200
	12	M 16×1.5 tap.	10.0	9.0	24	17.0	28	12	32	17	22	89	WE12LM	315	315	200
	15	M 18×1.5 tap.	12.0	11.0	28	21.0	32	12	36	19	27	78	WE15LM	315	315	200
	18	M 22×1.5 tap.	15.0	14.0	31	23.0	36	14	40	24	32	148	WE18LM	315	315	200
S ⁴⁾	06	M 12×1.5 tap.	4.0	4.0	23	16.0	26	12	31	12	17	53	WE06SM	400	400	250
	08	M 14×1.5 tap.	5.0	5.0	24	17.0	27	12	32	14	19	78	WE08SM	400	400	250
	10	M 16×1.5 tap.	7.0	7.0	25	17.5	28	12	34	17	22	102	WE10SM	400	400	250
	12	M 18×1.5 tap.	8.0	8.0	29	21.5	28	12	38	17	24	134	WE12SM	400	400	250
	16	M 22×1.5 tap.	12.0	12.0	33	24.5	32	14	43	24	30	161	WE16SM	400	400	250

¹⁾ Pressure shown = item deliverable

²⁾ LL = very light series; ³⁾ L = light series; ⁴⁾ S = heavy series

$$\frac{\text{PN (bar)}}{10} = \text{PN (MPa)}$$

Delivery without nut and ring. Information on ordering complete fittings see page 17.

*Please add the **suffixes** below according to the material/surface required.

Order code suffixes		
Material	Suffix surface and material	Example
Steel, zinc plated, Cr(VI)-free	CFX	WE16SMCFX
Stainless Steel	71X	WE16SM71X
Brass	MSX	WE16SMMSX

WE-M Male stud elbow

EO 24° cone end / Male metric thread – metal sealing edge (ISO 9974)

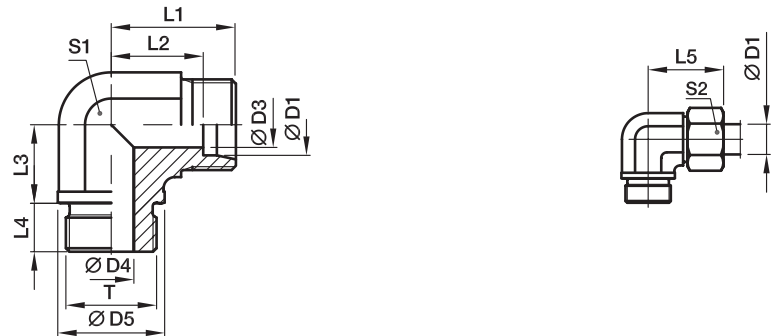

Series	D1	T	D3	D4	D5	L1	L2	L3	L4	L5	S1	S2	Weight g/1 piece	Order code*	PN (bar) ¹⁾	
															CF	71
L ³⁾	22	M 26×1.5	19	18	31	35	27.5	26	16	44	27	36	173	WE22LM	160	160
	28	M 33×2.0	24	23	39	38	30.5	30	18	47	36	41	303	WE28LM	160	160
	35	M 42×2.0	30	30	49	45	34.5	34	20	56	41	50	469	WE35LM	160	160
	42	M 48×2.0	36	36	55	51	40.0	39	22	63	50	60	661	WE42LM	160	160
S ⁴⁾	20	M 27×2.0	16	16	32	37	26.5	26	16	48	27	36	208	WE20SM	400	400
	25	M 33×2.0	20	20	39	42	30.0	30	18	54	36	46	396	WE25SM	250	250
	30	M 42×2.0	25	25	49	49	35.5	34	20	62	41	50	632	WE30SM	160	160
	38	M 48×2.0	32	32	55	57	41.0	39	22	72	50	60	907	WE38SM	160	160

¹⁾ Pressure shown = item deliverable

³⁾ L = light series; ⁴⁾ S = heavy series

$$\frac{\text{PN (bar)}}{10} = \text{PN (MPa)}$$

Delivery without nut and ring. Information on ordering complete fittings see page 17.

*Please add the **suffixes** below according to the material/surface required.

Order code suffixes		
Material	Suffix surface and material	Example
Steel, zinc plated, Cr(VI)-free	CFX	WE20SMCFX
Stainless Steel	71X	WE20SM71X

WE-R Male stud elbow

EO 24° cone end / Male BSPP thread – metal sealing edge (ISO 1179)

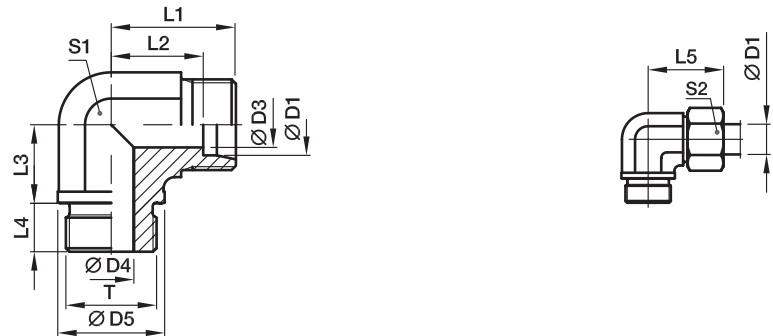

Series	D1	T	D3	D4	D5	L1	L2	L3	L4	L5	S1	S2	Weight g/1 piece	Order code*	PN (bar) ¹⁾		
															CF	71	MS
L ³⁾	22	G 3/4 A	19	18	32	35	27.5	26	16	44	27	36	168	WE22LR	160	160	100
	28	G 1 A	24	23	39	38	30.5	30	18	47	36	41	305	WE28LR	160	160	100
	35	G 1 1/4 A	30	30	49	45	34.5	34	20	56	41	50	465	WE35LR	160	160	100
	42	G 1 1/2 A	36	36	55	51	40.0	39	22	63	50	60	706	WE42LR	160	160	100
S ⁴⁾	20	G 3/4 A	16	16	32	37	26.5	26	16	48	27	36	210	WE20SR	400	400	250
	25	G 1 A	20	20	39	42	30.0	30	18	54	36	46	388	WE25SR	250	250	160
	30	G 1 1/4 A	25	25	49	49	35.5	34	20	62	41	50	630	WE30SR	160	160	100
	38	G 1 1/2 A	32	32	55	57	41.0	39	22	72	50	60	888	WE38SR	160	160	100

¹⁾ Pressure shown = item deliverable

³⁾ L = light series; ⁴⁾ S = heavy series

$$\frac{\text{PN (bar)}}{10} = \text{PN (MPa)}$$

Delivery without nut and ring. Information on ordering complete fittings see page 17.

Order code suffixes		
Material	Suffix surface and material	Example
Steel, zinc plated, Cr(VI)-free	CFX	WE20SRCFX
Stainless Steel	71X	WE20SR71X
Brass	MSX	WE20SRMSX

*Please add the **suffixes** below according to the material/surface required.

WE-R (KEG) Male stud elbow

EO 24° cone end / Male short BSP taper thread (DIN 3852-2, type C)

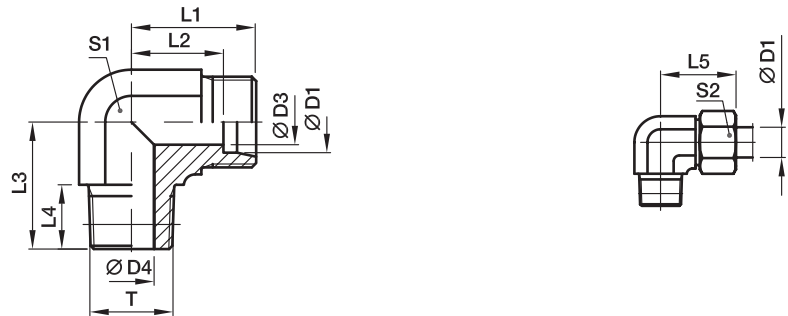

Series	D1	T	D3	D4	L1	L2	L3	L4	L5	S1	S2	Weight g/1 piece	Order code*	PN (bar) ¹⁾		
														CF	71	MS
LL ²⁾	04	R 1/8 tap.	3.0	4.0	15	11.0	17	8	21	9	10	17	WE04LLR	100	100	63
	06	R 1/8 tap.	4.5	4.5	15	9.5	17	8	21	9	12	17	WE06LLR	100	100	63
	08	R 1/8 tap.	6.0	6.0	17	11.5	20	8	23	12	14	24	WE08LLR	100	100	63
	10	R 1/4 tap.	8.0	7.0	18	12.5	23	12	24	12	17	36	WE10LLR	100		
	12	R 1/4 tap.	10.0	7.0	19	13.0	23	12	25	14	19	46	WE12LLR	100		
L ³⁾	06	R 1/8 tap.	4.0	4.0	19	12.0	20	8	27	12	14	30	WE06LR	315	315	200
	06	R 1/4 tap.	4.0	6.0	21	14.0	26	12	29	12	14	47	WE06LR1/4	315	315	
	08	R 1/4 tap.	6.0	6.0	21	14.0	26	12	29	12	17	46	WE08LR	315	315	200
	08	R 1/8 tap.	6.0	4.0	21	14.0	26	8	29	12	17	49	WE08LR1/8	315	315	
	08	R 3/8 tap.	6.0	9.0	24	17.0	28	12	32	17	17	94	WE08LR3/8	315	315	
	10	R 1/4 tap.	8.0	7.0	22	15.0	27	12	30	14	19	61	WE10LR	315	315	200
	10	R 3/8 tap.	8.0	9.0	24	17.0	28	12	32	17	19	87	WE10LR3/8	315	315	
	12	R 3/8 tap.	10.0	9.0	24	17.0	28	12	32	17	22	88	WE12LR	315	315	200
	12	R 1/4 tap.	10.0	7.0	24	17.0	27	12	32	17	22	80	WE12LR1/4	315	315	
	12	R 1/2 tap.	10.0	11.0	28	21.0	34	14	36	19	22	89	WE12LR1/2	315	315	
	15	R 1/2 tap.	12.0	11.0	28	21.0	34	14	36	19	27	94	WE15LR	315	315	200
	18	R 1/2 tap.	15.0	14.0	31	23.5	36	14	40	24	32	141	WE18LR	315	315	200
S ⁴⁾	06	R 1/4 tap.	4.0	4.0	23	16.0	26	12	31	12	17	56	WE06SR	400	400	250
	06	R 3/8 tap.	4.0	7.0	25	18.0	28	12	33	17	17	61	WE06SR3/8	400	400	
	08	R 1/4 tap.	5.0	5.0	24	17.0	27	12	32	14	19	73	WE08SR	400	400	250
	08	R 3/8 tap.	5.0	7.0	25	18.0	28	12	33	17	19	63	WE08SR3/8	400	400	
	10	R 3/8 tap.	7.0	7.0	25	17.5	28	12	34	17	22	104	WE10SR	400	400	250
	10	R 1/4 tap.	7.0	5.0	25	17.5	28	12	34	17	22	59	WE10SR1/4	400	400	
	10	R 1/2 tap.	7.0	10.0	30	22.5	32	14	39	19	22	98	WE10SR1/2	400	400	
	12	R 3/8 tap.	8.0	8.0	29	21.5	28	12	38	17	24	126	WE12SR	400	400	250
	12	R 1/2 tap.	8.0	11.0	30	22.5	32	14	39	19	24	97	WE12SR1/2	400	400	
	16	R 1/2 tap.	12.0	12.0	33	24.5	32	14	43	24	30	150	WE16SR	400	400	250

1) Pressure shown = item deliverable

2) LL = very light series; 3) L = light series; 4) S = heavy series

$$\frac{\text{PN (bar)}}{10} = \text{PN (MPa)}$$

Delivery without nut and ring. Information on ordering complete fittings see page 17.

*Please add the **suffixes** below according to the material/surface required.

Order code suffixes		
Material	Suffix surface and material	Example
Steel, zinc plated, Cr(VI)-free	CFX	WE16SRCFX
Stainless Steel	71X	WE16SR71X
Brass	MSX	WE16SRMSX

TE-M Male stud branch tee

EO 24° cone end / Male metric thread – metal sealing edge (ISO 9974)

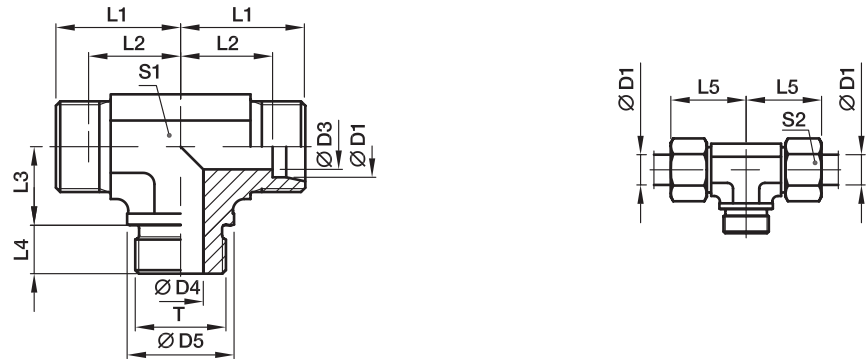

Series	D1	T	D3	D4	D5	L1	L2	L3	L4	L5	S1	S2	Weight g/1 piece	Order code*	PN (bar) ¹⁾	
															CF	71
L ³⁾	22	M 26×1.5	19	18	31	35	27.5	26	16	44	27	36	208	TE22LM	160	160
	28	M 33×2.0	24	23	39	38	30.5	30	18	47	36	41	352	TE28LM	160	160
	35	M 42×2.0	30	30	49	45	34.5	34	20	56	41	50	554	TE35LM	160	160
	42	M 48×2.0	36	36	55	51	40.0	39	22	63	50	60	847	TE42LM	160	160
S ⁴⁾	20	M 27×2.0	16	16	32	37	26.5	26	16	48	27	36	265	TE20SM	400	400
	25	M 33×2.0	20	20	39	42	30.0	30	18	54	36	46	482	TE25SM	250	250
	30	M 42×2.0	25	25	49	49	35.5	34	20	62	41	50	772	TE30SM	160	160
	38	M 48×2.0	32	32	55	57	41.0	39	22	72	50	60	1121	TE38SM	160	160

¹⁾ Pressure shown = item deliverable

³⁾ L = light series; ⁴⁾ S = heavy series

$$\frac{\text{PN (bar)}}{10} = \text{PN (MPa)}$$

Delivery without nut and ring. Information on ordering complete fittings see page 17.

Order code suffixes		
Material	Suffix surface and material	Example
Steel, zinc plated, Cr(VI)-free	CFX	TE20SMCFX
Stainless Steel	71X	TE20SM71X

*Please add the **suffixes** below according to the material/surface required.

TE-R Male stud branch tee

EO 24° cone end / Male BSPP thread – metal sealing edge (ISO 1179)

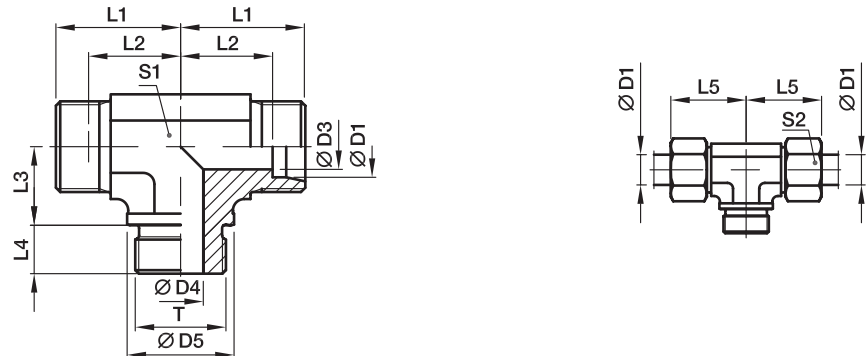

Series	D1	T	D3	D4	D5	L1	L2	L3	L4	L5	S1	S2	Weight g/1 piece	Order code*	PN (bar) ¹⁾		
															CF	71	MS
L ³⁾	22	G 3/4 A	19	18	32	35	27.5	26	16	44	27	36	208	TE22LR	160	160	100
	28	G 1 A	24	23	39	38	30.5	30	18	47	36	41	378	TE28LR	160	160	100
	35	G 1 1/4 A	30	30	49	45	34.5	34	20	56	41	50	554	TE35LR	160	160	100
	42	G 1 1/2 A	36	36	55	51	40.0	39	22	63	50	60	847	TE42LR	160	160	100
S ⁴⁾	20	G 3/4 A	16	16	32	37	26.5	26	16	48	27	36	267	TE20SR	400	400	250
	25	G 1 A	20	20	39	42	30.0	30	18	54	36	46	485	TE25SR	250	250	
	30	G 1 1/4 A	25	25	49	49	35.5	34	20	62	41	50	762	TE30SR	160	160	
	38	G 1 1/2 A	32	32	55	57	41.0	39	22	72	50	60	1121	TE38SR	160	160	

¹⁾ Pressure shown = item deliverable

³⁾ L = light series; ⁴⁾ S = heavy series

$$\frac{PN \text{ (bar)}}{10} = PN \text{ (MPa)}$$

Delivery without nut and ring. Information on ordering complete fittings see page 17.

*Please add the **suffixes** below according to the material/surface required.

Order code suffixes		
Material	Suffix surface and material	Example
Steel, zinc plated, Cr(VI)-free	CFX	TE20SRCFX
Stainless Steel	71X	TE20SR71X
Brass	MSX	TE20SRMSX

TE-R (KEG) Male stud branch tee

EO 24° cone end / Male short BSP taper thread (DIN 3852-2, type C)

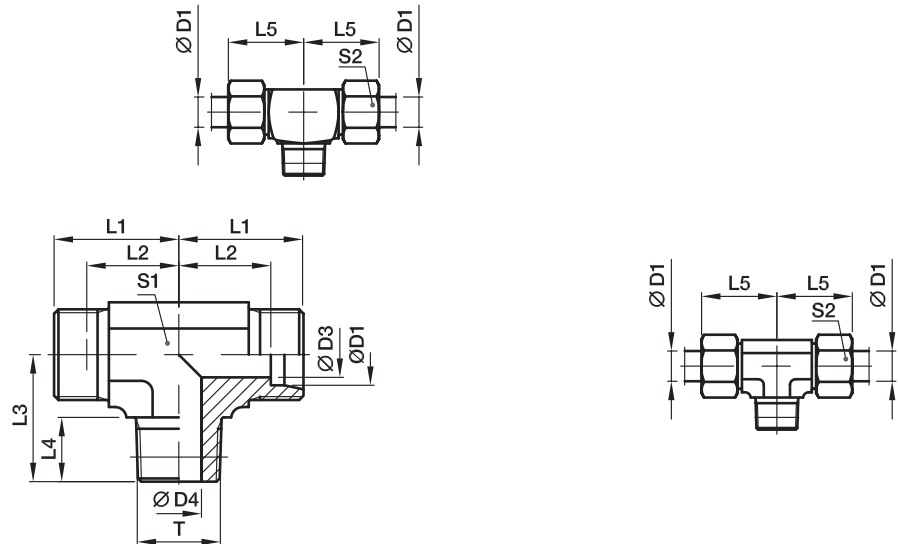

Series	D1	T	D3	D4	L1	L2	L3	L4	L5	S1	S2	Weight g/1 piece	Order code*	PN (bar) ¹⁾		
														CF	71	MS
LL ²⁾	04	R 1/8 tap.	3.0	4.0	15	11.0	17	8	21	9	10	21	TE04LLR	100	100	63
	06	R 1/8 tap.	4.5	4.5	15	9.5	17	8	21	9	12	21	TE06LLR	100	100	63
	08	R 1/8 tap.	6.0	6.0	17	11.5	20	8	23	12	14	29	TE08LLR	100	100	63
L ³⁾	06	R 1/8 tap.	4.0	4.0	19	12.0	20	8	27	14	14	38	TE06LR	315	315	200
	08	R 1/4 tap.	6.0	6.0	21	14.0	26	12	29	12	17	58	TE08LR	315	315	200
	10	R 1/4 tap.	8.0	7.0	22	15.0	27	12	30	14	19	43	TE10LR	315	315	200
	12	R 3/8 tap.	10.0	9.0	24	17.0	28	12	32	17	22	61	TE12LR	315	315	200
	15	R 1/2 tap.	12.0	11.0	28	21.0	34	14	36	19	27	113	TE15LR	315	315	200
	18	R 1/2 tap.	15.0	14.0	31	23.5	36	14	40	24	32	149	TE18LR	315	315	200
S ⁴⁾	06	R 1/4 tap.	4.0	4.0	23	16.0	26	12	31	12	17	73	TE06SR	400	400	250
	08	R 1/4 tap.	5.0	5.0	24	17.0	27	12	32	14	19	61	TE08SR	400	400	250
	10	R 3/8 tap.	7.0	7.0	25	17.5	28	12	34	17	22	82	TE10SR	400	400	250
	12	R 3/8 tap.	8.0	8.0	29	21.5	28	12	38	19*	24	105	TE12SR	400	400	250
	16	R 1/2 tap.	12.0	12.0	33	24.5	32	14	43	24	30	175	TE16SR	400	400	250

¹⁾ Pressure shown = item deliverable

²⁾ LL = very light series; ³⁾ L = light series; ⁴⁾ S = heavy series

*S1 = 17 in 1.4571

$$\frac{\text{PN (bar)}}{10} = \text{PN (MPa)}$$

Delivery without nut and ring. Information on ordering complete fittings see page I7.

*Please add the **suffixes** below according to the material/surface required.

Order code suffixes		
Material	Suffix surface and material	Example
Steel, zinc plated, Cr(VI)-free	CFX	TE16SRCFX
Stainless Steel	71X	TE16SR71X
Brass	MSX	TE16SRMSX

TE-M(KEG) Male stud branch tee

EO 24° cone end / Male short metric taper thread (DIN 3852-1, type C)

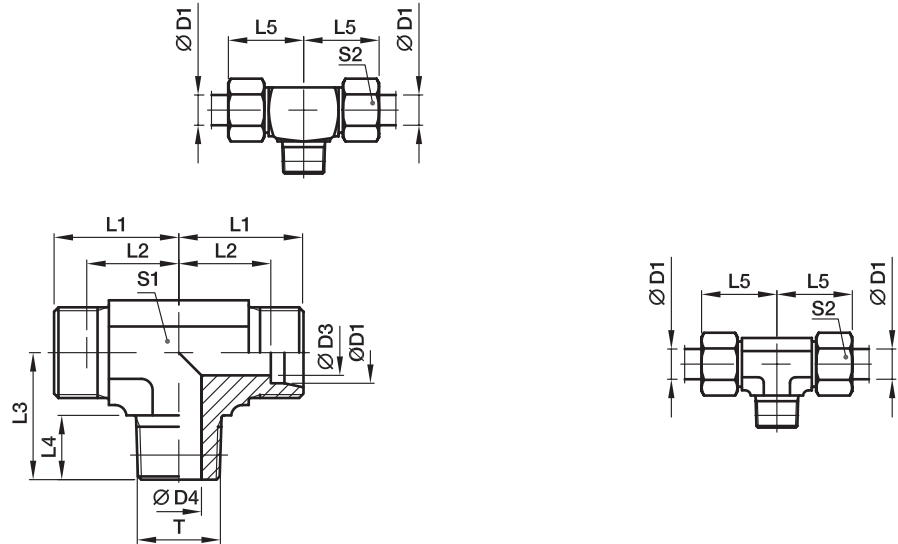

Series	D1	T	D3	D4	L1	L2	L3	L4	L5	S1	S2	Weight g/1 piece	Order code*	PN (bar) ¹⁾	
														CF	71
LL ²⁾	04	M 08×1.0 tap.	3.0	3.5	15	11.0	17	8	21	9	10	17	TE04LLM	100	100
	06	M 10×1.0 tap.	4.5	4.5	15	9.5	17	8	21	9	12	20	TE06LLM	100	100
	08	M 10×1.0 tap.	6.0	6.0	17	11.5	20	8	23	12	14	29	TE08LLM	100	100
L ³⁾	06	M 10×1.0 tap.	4.0	4.0	19	12.0	20	8	27	12	14	38	TE06LM	315	315
	08	M 12×1.5 tap.	6.0	6.0	21	14.0	26	12	29	12	17	54	TE08LM	315	315
	10	M 14×1.5 tap.	8.0	7.0	22	15.0	27	12	30	14	19	45	TE10LM	315	315
	12	M 16×1.5 tap.	10.0	9.0	24	17.0	28	12	32	17	22	60	TE12LM	315	315
	15	M 18×1.5 tap.	12.0	11.0	28	21.0	32	12	36	19	27	100	TE15LM	315	315
	18	M 22×1.5 tap.	15.0	14.0	31	23.5	36	14	40	24	32	149	TE18LM	315	315
S ⁴⁾	06	M 12×1.5 tap.	4.0	4.0	23	16.0	26	12	31	12	17	69	TE06SM	400	400
	08	M 14×1.5 tap.	5.0	5.0	24	17.0	27	12	32	14	19	98	TE08SM	400	400
	10	M 16×1.5 tap.	7.0	7.0	25	17.5	28	12	34	17	22	82	TE10SM	400	400
	12	M 18×1.5 tap.	8.0	8.0	29	21.5	28	12	38	19*	24	106	TE12SM	400	400
	16	M 22×1.5 tap.	12.0	12.0	33	24.5	32	14	43	24	30	177	TE16SM	400	400

¹⁾ Pressure shown = item deliverable

²⁾ LL = very light series; ³⁾ L = light series; ⁴⁾ S = heavy series

*S1 = 17 in 1.4571

$$\frac{PN \text{ (bar)}}{10} = PN \text{ (MPa)}$$

Delivery without nut and ring. Information on ordering complete fittings see page I7.

*Please add the **suffixes** below according to the material/surface required.

Order code suffixes		
Material	Suffix surface and material	Example
Steel, zinc plated, Cr(VI)-free	CFX	TE16SMCFX
Stainless Steel	71X	TE16SM71X

LE-M Male stud run tee

EO 24° cone end / Male metric thread – metal sealing edge (ISO 9974)

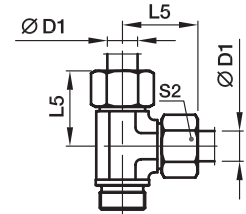
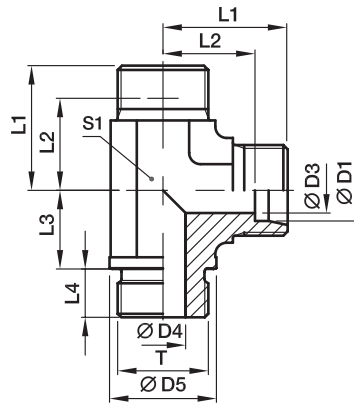

Series	D1	T	D3	D4	D5	L1	L2	L3	L4	L5	S1	S2	Weight g/1 piece	Order code*	PN (bar) ¹⁾	
															CF	71
L ³⁾	22	M 26×1.5	19	18	31	35	27.5	26	16	44	27	36	225	LE22LM	160	160
	28	M 33×2.0	24	23	39	38	30.5	30	18	47	36	41	382	LE28LM	160	160
	35	M 42×2.0	30	30	49	45	34.5	34	20	56	41	50	583	LE35LM	160	160
	42	M 48×2.0	36	36	55	51	40.0	39	22	63	50	60	821	LE42LM	160	160
S ⁴⁾	20	M 27×2.0	16	16	32	37	26.5	26	16	48	27	36	264	LE20SM	400	400
	25	M 33×2.0	20	20	39	42	30.0	30	18	54	36	46	497	LE25SM	250	250
	30	M 42×2.0	25	25	49	49	35.5	34	20	62	41	50	744	LE30SM	160	160
	38	M 48×2.0	32	32	55	57	41.0	39	22	72	50	60	1111	LE38SM	160	160

¹⁾ Pressure shown = item deliverable

³⁾ L = light series; ⁴⁾ S = heavy series

$$\frac{\text{PN (bar)}}{10} = \text{PN (MPa)}$$

Delivery without nut and ring. Information on ordering complete fittings see page I7.

*Please add the **suffixes** below according to the material/surface required.

Order code suffixes		
Material	Suffix surface and material	Example
Steel, zinc plated, Cr(VI)-free	CFX	LE20SMCFX
Stainless Steel	71X	LE20SM71X

LE-R Male stud run tee

EO 24° cone end / Male BSPP thread – metal sealing edge (ISO 1179)

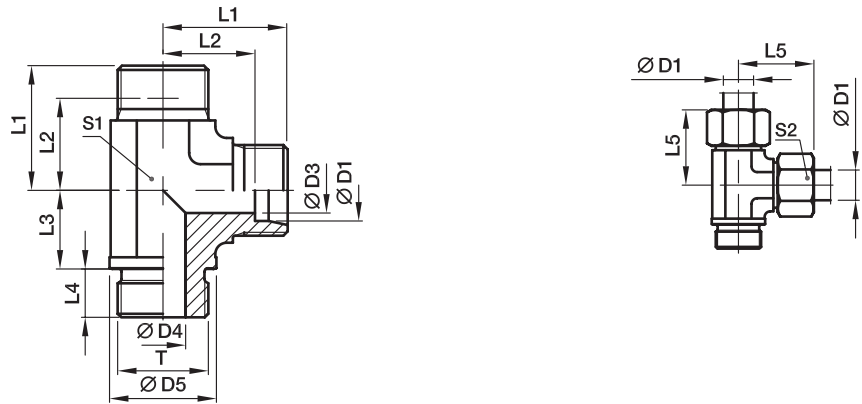

Series	D1	T	D3	D4	D5	L1	L2	L3	L4	L5	S1	S2	Weight g/1 piece	Order code*	PN (bar) ¹⁾	
															CF	71
L ³⁾	22	G 3/4 A	19	18	32	35	27.5	26	16	44	27	36	225	LE22LR	160	160
	28	G 1 A	24	23	39	38	30.5	30	18	47	36	41	358	LE28LR	160	160
	35	G 1 1/4 A	30	30	49	45	34.5	34	20	56	41	50	583	LE35LR	160	160
	42	G 1 1/2 A	36	36	55	51	40.0	39	22	63	50	60	821	LE42LR	160	160
S ⁴⁾	20	G 3/4 A	16	16	32	37	26.5	26	16	48	27	36	259	LE20SR	400	400
	25	G 1 A	20	20	39	42	30.0	30	18	54	36	46	495	LE25SR	250	250
	30	G 1 1/4 A	25	25	49	49	35.5	34	20	62	41	50	744	LE30SR	160	160
	38	G 1 1/2 A	32	32	55	57	41.0	39	22	72	50	60	1111	LE38SR	160	160

¹⁾ Pressure shown = item deliverable

³⁾ L = light series; ⁴⁾ S = heavy series

$\frac{\text{PN (bar)}}{10} = \text{PN (MPa)}$

Delivery without nut and ring. Information on ordering complete fittings see page I7.

*Please add the **suffixes** below according to the material/surface required.

Order code suffixes		
Material	Suffix surface and material	Example
Steel, zinc plated, Cr(VI)-free	CFX	LE20SRCFX
Stainless Steel	71X	LE20SR71X

LE-R (KEG) Male stud run tee

EO 24° cone end / Male short BSP taper thread (DIN 3852-2, type C)

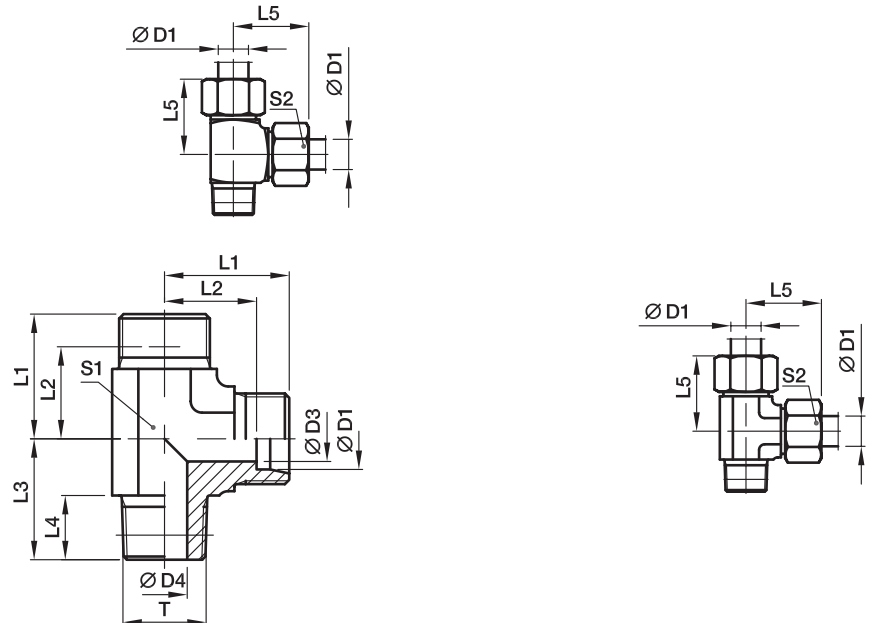

Series	D1	T	D3	D4	L1	L2	L3	L4	L5	S1	S2	Weight g/1 piece	Order code*	PN (bar) ¹⁾	
														CF	71
LL ²⁾	04	R 1/8 tap.	3.0	4.0	15	11.0	17	8	21	9	10	20	LE04LLR	100	100
	06	R 1/8 tap.	4.5	4.5	15	9.5	17	8	21	9	12	21	LE06LLR	100	100
	08	R 1/8 tap.	6.0	6.0	17	11.5	20	8	23	12	14	28	LE08LLR	100	100
L ³⁾	06	R 1/8 tap.	4.0	4.0	19	12.0	20	8	27	12	14	40	LE06LR	315	315
	08	R 1/4 tap.	6.0	6.0	21	14.0	26	12	29	12	17	57	LE08LR	315	315
	10	R 1/4 tap.	8.0	7.0	22	15.0	27	12	30	14	19	50	LE10LR	315	315
	12	R 3/8 tap.	10.0	9.0	24	17.0	28	12	32	17	22	60	LE12LR	315	315
	15	R 1/2 tap.	12.0	11.0	28	21.0	34	14	36	19	27	115	LE15LR	315	315
	18	R 1/2 tap.	15.0	14.0	31	23.5	36	14	40	24	32	145	LE18LR	315	315
S ⁴⁾	06	R 1/4 tap.	4.0	4.0	23	16.0	26	12	31	12	17	71	LE06SR	400	400
	08	R 1/4 tap.	5.0	5.0	24	17.0	27	12	32	14	19	62	LE08SR	400	400
	10	R 3/8 tap.	7.0	7.0	25	17.5	28	12	34	17	22	82	LE10SR	400	400
	12	R 3/8 tap.	8.0	8.0	29	21.5	28	12	38	19*	24	102	LE12SR	400	400
	16	R 1/2 tap.	12.0	12.0	33	24.5	32	14	43	24	30	193	LE16SR	400	400

¹⁾ Pressure shown = item deliverable

²⁾ LL = very light series; ³⁾ L = light series; ⁴⁾ S = heavy series

*S1 = 17 in 1.4571

PN (bar) = PN (MPa) / 10

Delivery without nut and ring. Information on ordering complete fittings see page 17.

*Please add the **suffixes** below according to the material/surface required.

Order code suffixes		
Material	Suffix surface and material	Example
Steel, zinc plated, Cr(VI)-free	CFX	LE16SRCFX
Stainless Steel	71X	LE16SR71X

LE-M(KEG) Male stud run tee

EO 24° cone end / Male short metric taper thread (DIN 3852-1, Form C)

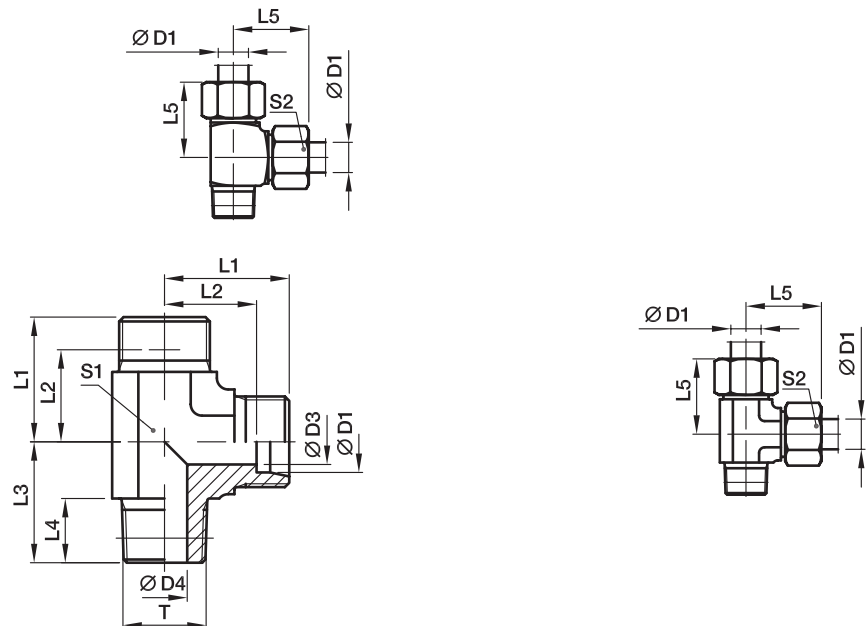

Series	D1	T	D3	D4	L1	L2	L3	L4	L5	S1	S2	Weight g/1 piece	Order code*	PN (bar) ¹⁾	
														CF	71
LL ²⁾	04	M 08×1.0 tap.	3.0	3.5	15	11.0	17	8	21	9	10	17	LE04LLM	100	100
	06	M 10×1.0 tap.	4.5	4.5	15	9.5	17	8	21	9	12	21	LE06LLM	100	100
	08	M 10×1.0 tap.	6.0	6.0	17	11.5	20	8	23	12	14	29	LE08LLM	100	100
L ³⁾	06	M 10×1.0 tap.	4.0	4.0	19	12.0	20	8	27	12	14	38	LE06LM	315	315
	08	M 12×1.5 tap.	6.0	6.0	21	14.0	26	12	29	12	17	56	LE08LM	315	315
	10	M 14×1.5 tap.	8.0	7.0	22	15.0	27	12	30	14	19	47	LE10LM	315	315
	12	M 16×1.5 tap.	10.0	9.0	24	17.0	28	12	32	17	22	58	LE12LM	315	315
	15	M 18×1.5 tap.	12.0	11.0	28	21.0	32	12	36	19	27	98	LE15LM	315	315
	18	M 22×1.5 tap.	15.0	14.0	31	23.5	36	14	40	24	32	156	LE18LM	315	315
S ⁴⁾	06	M 12×1.5 tap.	4.0	4.0	23	16.0	26	12	31	12	17	70	LE06SM	400	400
	08	M 14×1.5 tap.	5.0	5.0	24	17.0	27	12	32	14	19	66	LE08SM	400	400
	10	M 16×1.5 tap.	7.0	7.0	25	17.5	28	12	34	17	22	123	LE10SM	400	400
	12	M 18×1.5 tap.	8.0	8.0	29	21.5	28	12	38	19*	24	169	LE12SM	400	400
	16	M 22×1.5 tap.	12.0	12.0	33	24.5	32	14	43	24	30	178	LE16SM	400	400

¹⁾ Pressure shown = item deliverable

²⁾ LL = very light series; ³⁾ L = light series; ⁴⁾ S = heavy series

*S1 = 17 in 1.4571

PN (bar) = $\frac{\text{PN (MPa)}}{10}$

Delivery without nut and ring. Information on ordering complete fittings see page I7.

Order code suffixes		
Material	Suffix surface and material	Example
Steel, zinc plated, Cr(VI)-free	CFX	LE16SMCFX
Stainless Steel	71X	LE16SM71X

*Please add the **suffixes** below according to the material/surface required.

GAI-M Female connector

Female metric thread (ISO 9974-1) / EO 24° cone end

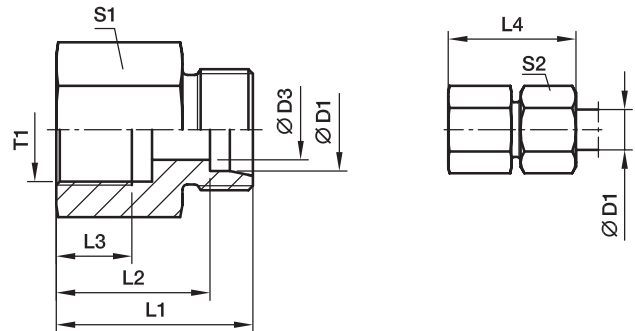

Series	D1	T1	D3	L1	L2	L3	L4	S1	S2	Weight g/1 piece	Order code*	PN (bar) ¹⁾	
												CF	71
L ³⁾	06	M 10×1.0	4	26.5	19.5	8.0	34	14	14	18	GAI06LM	315	315
	08	M 12×1.5	6	31.0	24.0	12.0	39	17	17	32	GAI08LM	315	315
	10	M 14×1.5	8	32.0	25.0	12.0	40	19	19	39	GAI10LM	315	315
	12	M 16×1.5	10	33.0	26.0	12.0	41	22	22	52	GAI12LM	315	315
	15	M 18×1.5	12	35.0	28.0	12.0	43	24	27	68	GAI15LM	315	315
	18	M 22×1.5	15	37.0	29.5	14.0	46	30	32	111	GAI18LM	315	315
	22	M 26×1.5	19	42.0	34.5	16.0	51	32	36	123	GAI22LM	160	160
	28	M 33×2.0	24	45.0	37.5	18.0	54	41	41	211	GAI28LM	160	160
	35	M 42×2.0	30	51.0	40.5	20.0	62	55	50	459	GAI35LM	160	160
	42	M 48×2.0	36	53.0	42.0	22.0	65	60	60	522	GAI42LM	160	160
S ⁴⁾	06	M 12×1.5	4	33.0	26.0	12.0	41	17	17	35	GAI06SM	400	400
	08	M 14×1.5	5	33.0	26.0	12.0	41	17	19	42	GAI08SM	400	400
	10	M 16×1.5	7	34.0	26.5	12.0	43	22	22	58	GAI10SM	400	400
	12	M 18×1.5	8	35.0	27.5	12.0	44	24	24	70	GAI12SM	400	400
	16	M 22×1.5	12	39.0	30.5	14.0	49	30	30	114	GAI16SM	400	400
	20	M 27×2.0	16	45.0	34.5	16.0	56	36	36	189	GAI20SM	315	315
	25	M 33×2.0	20	49.0	37.0	18.0	61	41	46	235	GAI25SM	315	315
	30	M 42×2.0	25	55.0	41.5	20.0	68	55	50	490	GAI30SM	315	315
38	M 48×2.0	32	59.0	43.0	22.0	74	60	60	597	GAI38SM	250	250	

¹⁾ Pressure shown = item deliverable

³⁾ L = light series; ⁴⁾ S = heavy series

$$\frac{\text{PN (bar)}}{10} = \text{PN (MPa)}$$

Delivery without nut and ring. Information on ordering complete fittings see page I7.

*Please add the **suffixes** below according to the material/surface required.

Order code suffixes		
Material	Suffix surface and material	Example
Steel, zinc plated, Cr(VI)-free	CFX	GAI16SMCFX
Stainless Steel	71X	GAI16SM71X

GAI-R Female connector

Female BSPP thread (ISO 1179-1) / EO 24° cone end

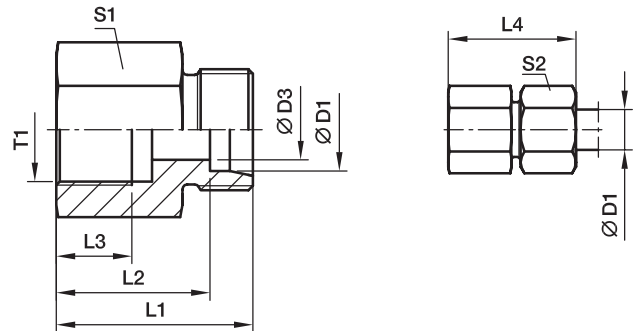

Series	D1	T1	D3	L1	L2	L3	L4	S1	S2	Weight g/1 piece	Order code*	PN (bar) ¹⁾		
												CF	71	MS
L ³⁾	06	G 1/8	4	26.0	19.0	8.0	34	14	14	18	GAI06LR	315	315	200
	06	G 1/4	4	31.0	24.0	12.0	39	19	14	39	GAI06LR1/4	315	315	200
	08	G 1/4	6	31.0	24.0	12.0	39	19	17	39	GAI08LR	315	315	200
	08	G 3/8	6	32.0	25.0	12.0	40	24	17	61	GAI08LR3/8	315	315	200
	08	G 1/2	6	36.0	29.0	14.0	44	27	17	80	GAI08LR1/2	315	315	200
	10	G 1/4	8	32.0	25.0	12.0	40	19	19	40	GAI10LR	315	315	200
	10	G 3/8	8	33.0	26.0	12.0	41	24	19	63	GAI10LR3/8	315	315	200
	10	G 1/2	8	37.0	30.0	14.0	45	27	19	81	GAI10LR1/2	315	315	200
	12	G 3/8	10	33.0	26.0	12.0	41	24	22	64	GAI12LR	315	315	200
	12	G 1/2	10	37.0	30.0	14.0	45	27	22	83	GAI12LR1/2	315	315	200
	15	G 1/2	12	38.0	31.0	14.0	46	27	27	87	GAI15LR	315	315	200
	18	G 1/2	15	38.0	30.5	14.0	47	27	32	89	GAI18LR	315	315	200
	18	G 3/8	15	34.0	26.5	12.0	43	27	32	95	GAI18LR3/8	315	315	200
	22	G 3/4	19	43.0	35.5	16.0	52	36	36	173	GAI22LR	160	160	100
	28	G 1	24	45.5	38.0	18.0	55	41	41	211	GAI28LR	160	160	100
	35	G 1 1/4	30	51.5	41.0	20.0	63	55	50	469	GAI35LR	160	160	100
42	G 1 1/2	36	53.5	42.5	22.0	65	60	60	540	GAI42LR	160	160	100	
S ⁴⁾	06	G 1/4	4	33.0	26.0	12.0	41	19	17	43	GAI06SR	400	400	
	08	G 1/4	5	33.0	26.0	12.0	41	19	19	47	GAI08SR	400	400	
	10	G 3/8	7	34.0	26.5	12.0	43	24	22	68	GAI10SR	400	400	
	12	G 3/8	8	34.0	26.5	12.0	43	24	24	71	GAI12SR	400	400	
	12	G 1/2	8	38.0	30.5	14.0	47	30	24	121	GAI12SR1/2	400	400	
	16	G 1/2	12	40.0	31.5	14.0	50	30	30	126	GAI16SR	400	400	
	20	G 3/4	16	45.0	34.5	16.0	56	36	36	196	GAI20SR	315	315	
	25	G 1	20	49.5	37.5	18.0	62	41	46	246	GAI25SR	315	315	
	30	G 1 1/4	25	55.5	42.0	22.0	69	55	50	537	GAI30SR	315	315	
	38	G 1 1/2	32	59.5	43.5	22.0	74	60	60	649	GAI38SR	250	250	

1) Pressure shown = item deliverable

3) L = light series; 4) S = heavy series

$$\frac{\text{PN (bar)}}{10} = \text{PN (MPa)}$$

Delivery without nut and ring. Information on ordering complete fittings see page I7.

*Please add the **suffixes** below according to the material/surface required.

Order code suffixes		
Material	Suffix surface and material	Example
Steel, zinc plated, Cr(VI)-free	CFX	GAI16SRCFX
Stainless Steel	71X	GAI16SR71X
Brass	MSX	GAI16SRMSX

GAI-NPT Female connector

Female NPT thread (SAE 476) / EO 24° cone end

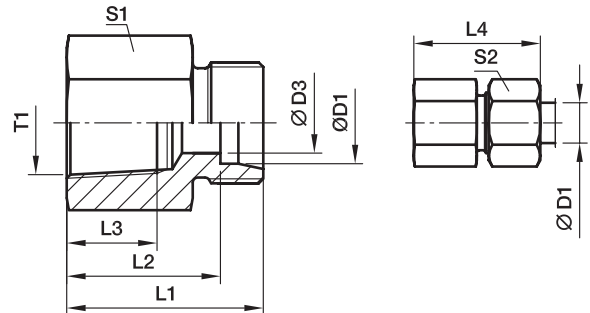

Series	D1	T1	D3	L1	L2	L3	L4	S1	S2	Weight g/1 piece	Order code*	PN (bar) ¹⁾	
												CF	71
L ³⁾	06	1/8-27 NPT	4	26.0	19.0	11.6	34	14	14	19	GAI06L1/8NPT	315	315
	06	1/4-18 NPT	4	30.5	23.5	16.4	38	19	14	38	GAI06L1/4NPT	315	315
	08	1/4-18 NPT	6	30.5	23.5	16.4	38	19	17	39	GAI08L1/4NPT	315	315
	10	1/4-18 NPT	8	31.0	24.0	16.4	39	19	19	40	GAI10L1/4NPT	315	315
	12	3/8-18 NPT	10	34.0	27.0	17.4	42	24	22	69	GAI12L3/8NPT	315	315
	12	1/2-14 NPT	10	39.0	32.0	22.6	47	27	22	91	GAI12L1/2NPT	315	315
	15	1/2-14 NPT	12	40.0	33.0	22.6	48	27	27	96	GAI15L1/2NPT	315	315
	18	1/2-14 NPT	15	40.0	32.5	22.6	49	27	32	99	GAI18L1/2NPT	315	315
	22	3/4-14 NPT	19	43.0	35.5	23.1	52	36	36	184	GAI22L3/4NPT	160	160
	28	1-11.5 NPT	24	48.0	40.5	27.8	57	41	41	238	GAI28L1NPT	160	160
	35	1 1/4-11.5 NPT	30	51.0	40.5	28.3	62	55	50	424	GAI35L11/4NPT	160	160
	42	1 1/2-11.5 NPT	36	53.0	42.0	28.3	65	60	60	547	GAI42L11/2NPT	160	160
S ⁴⁾	06	1/8-27 NPT	4	29.0	22.0	11.6	36	14	17	25	GAI06S1/8NPT	400	400
	06	1/4-18 NPT	4	33.0	26.0	16.4	41	19	17	41	GAI06S1/4NPT	400	400
	08	1/4-18 NPT	5	33.0	26.0	16.4	41	19	19	42	GAI08S1/4NPT	400	400
	10	3/8-18 NPT	7	35.0	27.0	17.4	44	24	22	74	GAI10S3/8NPT	400	400
	12	1/4-18 NPT	8	32.5	25.0	16.4	41	22	24	81	GAI12S1/4NPT	400	400
	12	3/8-18 NPT	8	35.0	27.5	17.4	44	24	24	76	GAI12S3/8NPT	400	400
	12	1/2-14 NPT	8	41.0	33.5	22.6	50	27	24	101	GAI12S1/2NPT	400	400
	16	1/2-14 NPT	12	43.0	34.5	22.6	50	27	30	111	GAI16S1/2NPT	400	400
	20	1/2-14 NPT	16	44.0	33.5	22.6	55	32	36	129	GAI20S1/2NPT	315	315
	20	3/4-14 NPT	16	46.0	35.5	23.1	57	36	36	214	GAI20S3/4NPT	315	315
	25	1-11.5 NPT	20	53.0	41.0	27.8	65	41	46	288	GAI25S1NPT	315	315
	30	1 1/4-11.5 NPT	25	57.0	43.5	28.3	70	55	50	559	GAI30S11/4NPT	315	315
38	1 1/2-11.5 NPT	32	59.0	43.0	28.3	74	60	60	632	GAI38S11/2NPT	250	250	

¹⁾ Pressure shown = item deliverable

³⁾ L = light series; ⁴⁾ S = heavy series

$$\frac{\text{PN (bar)}}{10} = \text{PN (MPa)}$$

Delivery without nut and ring. Information on ordering complete fittings see page I7.

*Please add the **suffixes** below according to the material/surface required.

Order code suffixes		
Material	Suffix surface and material	Example
Steel, zinc plated, Cr(VI)-free	CFX	GAI16S1/2NPTCFX
Stainless Steel	71X	GAI16S1/2NPT71X

RI-ED Thread reducer/expander

Male BSPP thread – ED-seal (ISO 1179) / Female BSPP thread (ISO 1179-1)

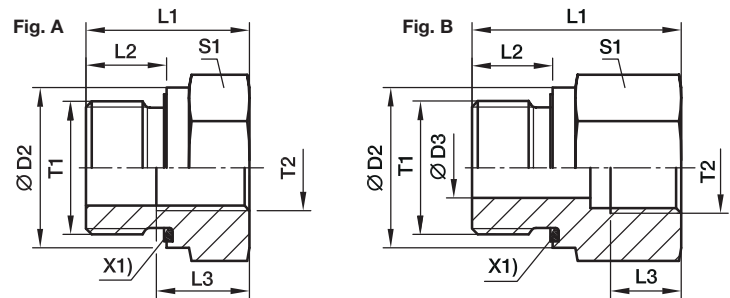

X1) Elastic-sealing ED

Male Stud T1	Female Stud T2	D2	D3	L1	L2	L3	S1	Fig.	Weight g/1 piece	Order code*	PN (bar) ¹⁾	
											CF	71
G 1/8 A	G 1/4	14	4	31.0	8	12.0	19	B	41	RI1/8EDX1/4	400	400
G 1/8 A	G 3/8	14	4	32.0	8	12.0	24	B	63	RI1/8EDX3/8	400	400
G 1/4 A	G 1/8	19	5	29.0	12	8.0	19	B	41	RI1/4EDX1/8	400	400
G 1/4 A	G 3/8	19	5	36.0	12	12.0	24	B	69	RI1/4EDX3/8	400	400
G 1/4 A	G 1/2	19	5	40.0	12	14.0	30	B	120	RI1/4EDX1/2	400	400
G 1/4 A	G 3/4	19	5	43.0	12	16.0	36	B	171	RI1/4EDX3/4	400	400
G 3/8 A	G 1/8	22		22.5	12	8.0	22	A	38	RI3/8EDX1/8	400	400
G 3/8 A	G 1/4	22	8	36.0	12	12.0	22	B	68	RI3/8EDX1/4	400	400
G 3/8 A	G 1/2	22	8	41.0	12	14.0	30	B	124	RI3/8EDX1/2	400	400
G 3/8 A	G 3/4	22	8	44.0	12	16.0	36	B	182	RI3/8EDX3/4	315	315
G 1/2 A	G 1/8	27		24.0	14	8.0	27	A	65	RI1/2EDX1/8	400	400
G 1/2 A	G 1/4	27		24.0	14	12.0	27	A	56	RI1/2EDX1/4	400	400
G 1/2 A	G 3/8	27	12	37.0	14	12.0	27	B	95	RI1/2EDX3/8	400	400
G 1/2 A	G 3/4	27	12	46.0	14	16.0	36	B	183	RI1/2EDX3/4	315	315
G 1/2 A	G 1	27	12	49.0	14	18.0	41	B	232	RI1/2EDX1	315	315
G 1/2 A	G 1 1/4	27	10	53.0	14	20.0	55	B	481	RI1/2EDX11/4	315	315
G 3/4 A	G 1/4	32		26.0	16	12.0	32	A	103	RI3/4EDX1/4	315	315
G 3/4 A	G 3/8	32		26.0	16	12.0	32	A	86	RI3/4EDX3/8	315	315
G 3/4 A	G 1/2	32	16	43.0	16	14.0	32	B	156	RI3/4EDX1/2	315	315
G 3/4 A	G 1	32	16	51.0	16	18.0	41	B	237	RI3/4EDX1	315	315
G 3/4 A	G 1 1/4	32	16	55.0	16	20.0	55	B	486	RI3/4EDX11/4	315	315
G 3/4 A	G 1 1/2	32	16	57.0	16	22.0	60	B	561	RI3/4EDX11/2	250	250
G 1 A	G 1/4	40		29.0	18	12.0	41	A	197	RI1EDX1/4	315	315
G 1 A	G 3/8	40		29.0	18	12.0	41	A	179	RI1EDX3/8	315	315
G 1 A	G 1/2	40		29.0	18	14.0	41	A	153	RI1EDX1/2	315	315
G 1 A	G 3/4	40	20	49.0	18	16.0	41	B	290	RI1EDX3/4	315	315
G 1 A	G 1 1/4	40	20	57.0	18	20.0	55	B	503	RI1EDX11/4	315	315
G 1 A	G 1 1/2	40	20	59.0	18	22.0	60	B	585	RI1EDX11/2	250	250
G 1 1/4 A	G 1/2	50		32.0	20	14.0	50	A	313	RI11/4EDX1/2	315	315
G 1 1/4 A	G 3/4	50		32.0	20	16.0	50	A	393	RI11/4EDX3/4	315	315
G 1 1/4 A	G 1	50	25	52.0	20	18.0	50	B	469	RI11/4EDX1	315	315
G 1 1/4 A	G 1 1/2	50	25	60.0	20	22.0	60	B	624	RI11/4EDX11/2	250	250
G 1 1/2 A	G 1/2	55		36.0	22	14.0	55	A	470	RI11/2EDX1/2	250	250
G 1 1/2 A	G 3/4	55		36.0	22	16.0	55	A	415	RI11/2EDX3/4	250	250
G 1 1/2 A	G 1	55		36.0	22	18.0	55	A	338	RI11/2EDX1	250	250
G 1 1/2 A	G 1 1/4	55	32	58.0	22	20.0	55	B	542	RI11/2EDX11/4	250	250
G 2 A	G 1 1/2	75	40	65.0	24	22.0	75	B	1309	RI2EDX11/2	160	

¹⁾ Pressure shown = item deliverable

PN (bar) = PN (MPa)
10

Information on ordering alternative sealing materials see page 17.

*Please add the **suffixes** below according to the material/surface required.

Order code suffixes			
Material	Suffix surface and material	Example	Standard sealing material (no additional suffix needed)
Steel, zinc plated, Cr(VI)-free	CF	RI1EDX1/2CF	NBR
Stainless Steel	71	RI1EDX1/271	VIT

RI Thread reducer/expander

Male BSPP thread – metal sealing edge (ISO 1179) / Female BSPP thread (ISO 1179-1)

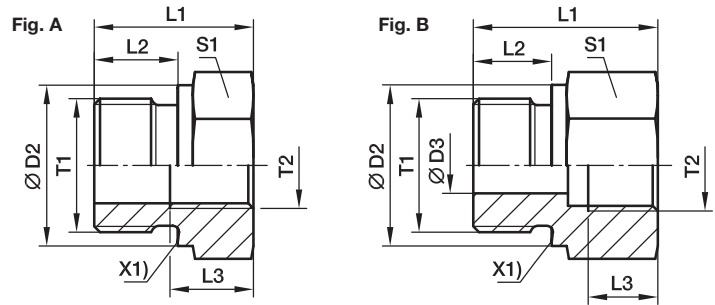

X1) metal sealing edge

Male Stud T1	Female Stud T2	D2	D3	L1	L2	L3	S1	Fig.	Weight g/1 piece	Order code*	PN (bar) ¹⁾		
											CF	71	MS
G 1/8 A	G 1/4	14	4	31.0	8	12.0	19	B	42	RI1/8X1/4	400	400	250
G 1/8 A	G 3/8	14	4	32.0	8	12.0	24	B	63	RI1/8X3/8	400	400	250
G 1/4 A	G 1/8	18	5	28.0	12	8.0	19	B	38	RI1/4X1/8	400	400	250
G 1/4 A	G 3/8	18	5	36.0	12	12.0	24	B	69	RI1/4X3/8	400	400	250
G 1/4 A	G 1/2	18	5	40.0	12	14.0	30	B	116	RI1/4X1/2	400	400	250
G 1/4 A	G 3/4	18	5	43.0	12	16.0	36	B	170	RI1/4X3/4	315	315	200
G 3/8 A	G 1/8	22		22.5	12	8.0	22	A	39	RI3/8X1/8	400	400	250
G 3/8 A	G 1/4	22	8	36.0	12	12.0	22	B	68	RI3/8X1/4	400	400	250
G 3/8 A	G 1/2	22	8	41.0	12	14.0	30	B	125	RI3/8X1/2	400	400	250
G 3/8 A	G 3/4	22	8	44.0	12	16.0	36	B	183	RI3/8X3/4	315	315	200
G 1/2 A	G 1/8	26		24.0	14	8.0	27	A	66	RI1/2X1/8	400	400	250
G 1/2 A	G 1/4	26		24.0	14	12.0	27	A	56	RI1/2X1/4	315	315	200
G 1/2 A	G 3/8	26	12	37.0	14	12.0	27	B	94	RI1/2X3/8	315	315	200
G 1/2 A	G 3/4	26	12	46.0	14	16.0	36	B	182	RI1/2X3/4	315	315	200
G 1/2 A	G 1	26	12	49.0	14	18.0	41	B	221	RI1/2X1	315	315	200
G 1/2 A	G 1 1/4	26	10	53.0	14	20.0	55	B	482	RI1/2X11/4	160	160	
G 3/4 A	G 1/4	32		26.0	16	12.0	32	A	103	RI3/4X1/4	315	315	200
G 3/4 A	G 3/8	32		26.0	16	12.0	32	A	87	RI3/4X3/8	315	315	200
G 3/4 A	G 1/2	32	16	40.0	16	14.0	32	B	143	RI3/4X1/2	315	315	200
G 3/4 A	G 1	32	16	51.0	16	18.0	41	B	235	RI3/4X1	315	315	200
G 3/4 A	G 1 1/4	32	16	55.0	16	20.0	55	B	481	RI3/4X11/4	160	160	
G 3/4 A	G 1 1/2	32	16	57.0	16	22.0	60	B	560	RI3/4X11/2	160	160	
G 1 A	G 1/4	39		29.0	18	12.0	41	A	195	RI1X1/4	315	315	
G 1 A	G 3/8	39		29.0	18	12.0	41	A	179	RI1X3/8	315	315	200
G 1 A	G 1/2	39		29.0	18	14.0	41	A	157	RI1X1/2	315	315	200
G 1 A	G 3/4	39	20	47.0	18	16.0	41	B	278	RI1X3/4	315	315	200
G 1 A	G 1 1/4	39	20	57.0	18	20.0	55	B	530	RI1X11/4	160	160	100
G 1 A	G 1 1/2	39	20	59.0	18	22.0	60	B	585	RI1X11/2	160	160	100
G 1 1/4 A	G 1/2	49		32.0	20	14.0	50	A	308	RI11/4X1/2	160	160	100
G 1 1/4 A	G 3/4	49		32.0	20	16.0	50	A	267	RI11/4X3/4	160	160	100
G 1 1/4 A	G 1	49	25	52.0	20	18.0	50	B	458	RI11/4X1	160	160	100
G 1 1/4 A	G 1 1/2	49	25	60.0	20	22.0	60	B	616	RI11/4X11/2	160	160	100
G 1 1/2 A	G 1/2	55		36.0	22	14.0	55	A	477	RI11/2X1/2	160	160	100
G 1 1/2 A	G 3/4	55		36.0	22	16.0	55	A	402	RI11/2X3/4	160	160	100
G 1 1/2 A	G 1	55		36.0	22	18.0	55	A	337	RI11/2X1	160	160	100
G 1 1/2 A	G 1 1/4	55	32	58.0	22	20.0	55	B	542	RI11/2X11/4	160	160	100
G 2 A	G 1 1/2	68	40	62.0	24	22.0	70	B	990	RI2X11/2	160		

¹⁾ Pressure shown = item deliverable

$$\frac{\text{PN (bar)}}{10} = \text{PN (MPa)}$$

*Please add the **suffixes** below according to the material/surface required.

Order code suffixes		
Material	Suffix surface and material	Example
Steel, zinc plated, Cr(VI)-free	CFX	RI1X1/2CFX
Stainless Steel	71X	RI1X1/271X
Brass	MSX	RI1X1/2MSX

MAV Pressure gauge connector

Female BSPP thread / EO 24° cone end
Port acc. to ISO 1179-1

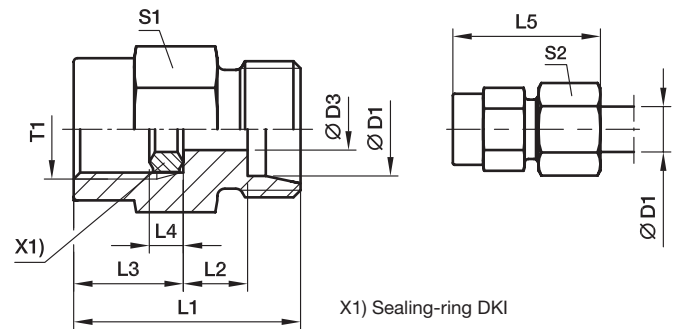

Series	D1	T1	D3	L1	L2	L3	L4	L5	S1	S2	Weight g/1 piece	Order code*	PN (bar) ¹⁾		
													CF	71	MS
LL ²⁾	04	G 1/4	2.5	27	7.5	15.5	4.5	33	19	10	33	MAV04LLROMD	100		
L ³⁾	06	G 1/4	2.5	29	6.5	15.5	4.5	37	19	14	37	MAV06LROMD	500	315	200
	08	G 1/4	5.5	29	6.5	15.5	4.5	37	19	17	38	MAV08LROMD	500	315	200
	10	G 1/4	5.5	30	6.5	15.5	4.5	38	19	19	41	MAV10LROMD	500	315	200
	12	G 1/4	5.5	30	6.5	15.5	4.5	38	19	22	43	MAV12LROMD	400	315	200
S ⁴⁾	06	G 1/2	3.5	38	11.0	20.0	5.0	46	27	17	86	MAV06SROMD	630	630	400
	08	G 1/2	3.5	38	11.0	20.0	5.0	46	27	19	86	MAV08SROMD	630	630	400
	10	G 1/2	7.5	38	10.5	20.0	5.0	47	27	22	88	MAV10SROMD	630	630	400
	12	G 1/2	7.5	38	10.5	20.0	5.0	47	27	24	93	MAV12SROMD	630	630	400

¹⁾ Pressure shown = item deliverable

²⁾ LL = very light series; ³⁾ L = light series; ⁴⁾ S = heavy series

$\frac{\text{PN (bar)}}{10} = \text{PN (MPa)}$

Delivery without nut and ring. Information on ordering complete fittings see page I7.

*Please add the **suffixes** below according to the material/surface required.

Order code suffixes		
Material	Suffix surface and material	Example
Steel, zinc plated, Cr(VI)-free	CF	MAV10SROMDCF
Stainless Steel	71	MAV10SROMD71
Brass	MS	MAV10SROMDMS

MAVE Pressure gauge swivel connector

Female BSPP thread / EO 24° DKO swivel
Port acc. to ISO 1179-1

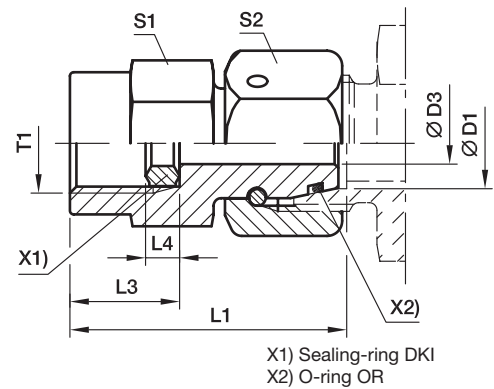

Series	D1 	T1	D3	L1	L3	L4	S1	S2	Weight g/1 piece	Order code*	PN (bar) ¹⁾	
											CF	71
L ³⁾	06	G 1/4	2.5	35.5	15.5	4.5	19	14	46	MAVE06LR	500	315
	08	G 1/4	4.0	35.5	15.5	4.5	19	17	52	MAVE08LR	500	315
	10	G 1/4	5.5	36.0	15.5	4.5	19	19	59	MAVE10LR	500	315
	12	G 1/4	5.5	36.0	15.5	4.5	19	22	70	MAVE12LR	400	315
S ⁴⁾	06	G 1/2	2.5	42.5	20.0	5.0	27	17	95	MAVE06SR	630	630
	06	G 1/4	2.5	35.5	15.5	4.5	19	17	52	MAVE06SR1/4	630	630
	08	G 1/2	4.0	43.0	20.0	5.0	27	19	100	MAVE08SR	630	630
	08	G 1/4	4.0	35.5	15.5	4.5	19	19	58	MAVE08SR1/4	630	630
	10	G 1/2	6.0	43.5	20.0	5.0	27	22	109	MAVE10SR	630	630
	10	G 1/4	7.0	39.0	15.5	4.5	19	22	67	MAVE10SR1/4	630	630
	12	G 1/2	7.0	45.0	20.0	5.0	27	24	125	MAVE12SR	630	630
	12	G 1/4	7.0	39.0	15.5	4.5	19	24	83	MAVE12SR1/4	630	630

¹⁾ Pressure shown = item deliverable

³⁾ L = light series; ⁴⁾ S = heavy series

$$\frac{\text{PN (bar)}}{10} = \text{PN (MPa)}$$

Information on ordering alternative sealing materials see page 17.

*Please add the **suffixes** below according to the material/surface required.

Order code suffixes			
Material	Suffix surface and material	Example	Standard sealing material (no additional suffix needed)
Steel, zinc plated, Cr(VI)-free	CF	MAVE10SRCF	NBR
Stainless Steel	71	MAVE10SR71	VIT

ROV Blanking plug for tube ends

EO 24° cone end

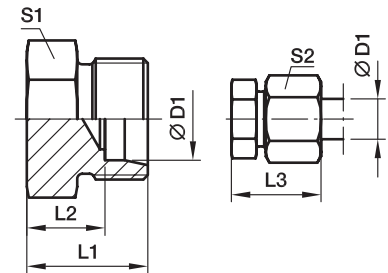

Series	D1 	L1	L2	L3	S1	S2	Weight g/1 piece	Order code*	PN (bar) ¹⁾	
									CF	71
L ³⁾	06	14	7.0	22	12	14	8	ROV06L	315	315
	08	15	8.0	23	14	17	13	ROV08L	315	315
	10	16	9.0	24	17	19	17	ROV10L	315	315
	12	17	10.0	25	19	22	24	ROV12L	315	315
	15	18	11.0	26	24	27	41	ROV15L	315	315
	18	19	11.5	28	27	32	56	ROV18L	315	315
	22	21	13.5	30	32	36	84	ROV22L	160	160
	28	22	14.5	31	41	41	138	ROV28L	160	160
	35	25	14.5	36	46	50	203	ROV35L	160	160
	42	27	16.0	39	55	60	318	ROV42L	160	160
S ⁴⁾	06	18	11.0	26	14	17	17	ROV06S	630	630
	08	20	13.0	28	17	19	28	ROV08S	630	630
	10	20	12.5	29	19	22	33	ROV10S	630	630
	12	22	14.5	31	22	24	50	ROV12S	630	630
	16	24	15.5	34	27	30	75	ROV16S	400	400
	20	28	17.5	39	32	36	125	ROV20S	400	400
	25	32	20.0	44	41	46	229	ROV25S	400	400
	30	34	20.5	47	46	50	310	ROV30S	400	400
	38	39	23.0	54	55	60	508	ROV38S	315	315

¹⁾ Pressure shown = item deliverable

³⁾ L = light series; ⁴⁾ S = heavy series

$\frac{\text{PN (bar)}}{10} = \text{PN (MPa)}$

Delivery without nut and ring. Information on ordering complete fittings see page I7.

*Please add the **suffixes** below according to the material/surface required.

Order code suffixes		
Material	Suffix surface and material	Example
Steel, zinc plated, Cr(VI)-free	CFX	ROV16SCFX
Stainless Steel	71X	ROV16S71X

VSTI M-OR Blanking plug for ports

Male metric thread – O-ring (ISO 6149)

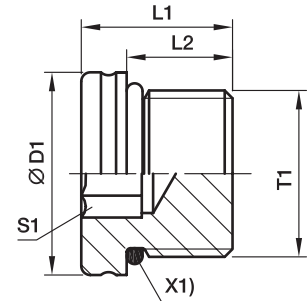

X1) O-ring OR

T1	D1	L1	L2	S1	Weight g/1 piece	Order code*	PN (bar) ¹⁾ CF
M 08x1.0	12	13.0	9.5	4	6	VSTI8X1OR	630
M 10x1.0	13	13.5	9.5	5	8	VSTI10X1OR	630
M 12x1.5	17	15.0	11.0	6	14	VSTI12X1.5OR	630
M 14x1.5	19	16.0	11.0	6	20	VSTI14X1.5OR	630
M 16x1.5	21	17.5	12.5	8	26	VSTI16X1.5OR	630
M 18x1.5	23	19.0	14.0	8	37	VSTI18X1.5OR	630
M 22x1.5	27	20.0	15.0	10	58	VSTI22X1.5OR	630
M 26x1.5	31	21.0	16.0	12	77	VSTI26X1.5OR	400
M 27x2.0	32	23.5	18.5	12	95	VSTI27X2OR	400
M 33x2.0	38	25.0	18.5	14	148	VSTI33X2OR	400
M 42x2.0	48	25.5	19.0	22	233	VSTI42X2OR	400
M 48x2.0	55	28.0	21.5	24	336	VSTI48X2OR	400

¹⁾ Pressure shown = item deliverable

$$\frac{\text{PN (bar)}}{10} = \text{PN (MPa)}$$

Information on ordering alternative sealing materials see page 17.

*Please add the **suffixes** below according to the material/surface required.

Order code suffixes			
Material	Suffix surface and material	Example	Standard sealing material (no additional suffix needed)
Steel, zinc plated, Cr(VI)-free	CF	VSTI18X1.5ORCF	NBR

VSTI M/R-ED Blanking plug for ports

Male metric thread – ED-seal (ISO 9974)

Male BSPP thread – ED-seal (ISO 1179)

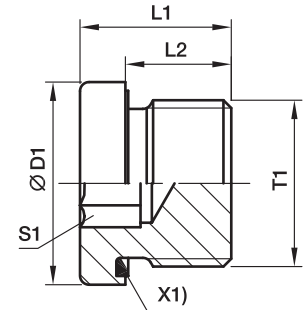

X1) Eolastic-sealing ED

Male metric parallel thread T1	Male stud BSP thread T1	D1	L1	L2	S1	Weight g/1 piece	Order code*	Order code*	PN (bar) ¹⁾	
									CF	71
M 10×1.0	G 1/8 A	14.0	12.3	8	5	8	VSTI10X1ED	VSTI1/8ED	400	400
M 12×1.5		17.0	17.3	12	6	14	VSTI12X1.5ED		400	400
M 14×1.5	G 1/4 A	19.0	17.3	12	6	20	VSTI14X1.5ED	VSTI1/4ED	400	400
M 16×1.5	G 3/8 A	22.0	17.3	12	8	25	VSTI16X1.5ED	VSTI3/8ED	400	400
M 18×1.5		24.0	17.3	12	8	32	VSTI18X1.5ED		400	400
M 20×1.5		26.0	19.3	14	10	42	VSTI20X1.5ED		400	400
M 22×1.5	G 1/2 A	27.0	19.3	14	10	51	VSTI22X1.5ED	VSTI1/2ED	400	400
M 26×1.5		32.0	21.3	16	12	78	VSTI26X1.5ED		400	400
M 27×2.0	G 3/4 A	32.0	21.3	16	12	79	VSTI27X2ED	VSTI3/4ED	400	400
M 33×2.0	G 1 A	40.0	22.8	16	17	130	VSTI33X2ED	VSTI1ED	400	400
M 42×2.0	G 1 1/4 A	50.0	22.8	16	22	198	VSTI42X2ED	VSTI11/4ED	315	315
M 48×2.0	G 1 1/2 A	55.0	22.8	16	24	263	VSTI48X2ED	VSTI11/2ED	315	315

¹⁾ Pressure shown = item deliverable

$$\frac{\text{PN (bar)}}{10} = \text{PN (MPa)}$$

Information on ordering alternative sealing materials see page 17.

*Please add the **suffixes** below according to the material/surface required.

Order code suffixes			
Material	Suffix surface and material	Example	Standard sealing material (no additional suffix needed)
Steel, zinc plated, Cr(VI)-free	CF	VSTI1/2EDCF	NBR
Stainless Steel	71	VSTI1/2ED71	VIT

VKA Blanking plug for cones

EO 24° DKO swivel

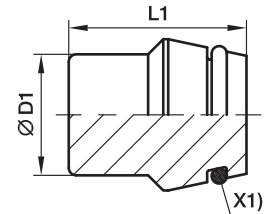

X1) O-ring OR

Series	D1 	L1	Weight g/1 piece	Order code*	PN (bar) ¹⁾		
					CF	71	MS
L ³⁾	06	18.5	6	VKA06	500	315	200
	08	18.5	9	VKA08	500	315	200
	10	20.0	15	VKA10	500	315	200
	12	20.5	21	VKA12	400	315	200
	15	20.5	32	VKA15	400	315	200
	18	22.5	49	VKA18	400	315	200
	22	25.0	80	VKA22	250	160	100
	28	25.5	131	VKA28	250	160	100
	35	30.0	240	VKA35	250	160	100
	42	30.0	343	VKA42	250	160	100
S ⁴⁾	06	18.5	6	VKA06	800	630	400
	08	18.5	9	VKA08	800	630	400
	10	20.0	15	VKA10	800	630	400
	12	20.5	21	VKA12	630	630	400
	16	23.5	40	VKA16	630	400	250
	20	28.5	78	VKA20	420	400	250
	25	29.0	120	VKA25	420	400	250
	30	30.5	180	VKA30	420	400	250
	38	33.0	309	VKA38	420	315	200

¹⁾ Pressure shown = item deliverable

³⁾ L = light series; ⁴⁾ S = heavy series

$$\frac{\text{PN (bar)}}{10} = \text{PN (MPa)}$$

Information on ordering alternative sealing materials see page 17.

*Please add the **suffixes** below according to the material/surface required.

Order code suffixes			
Material	Suffix surface and material	Example	Standard sealing material (no additional suffix needed)
Steel, zinc plated, Cr(VI)-free	CF	VKA16CF	NBR
Stainless Steel	71	VKA1671	VIT
Brass	MS	VKA16MS	NBR

VKAM Blanking plug with nut for cone

EO 24° DKO swivel

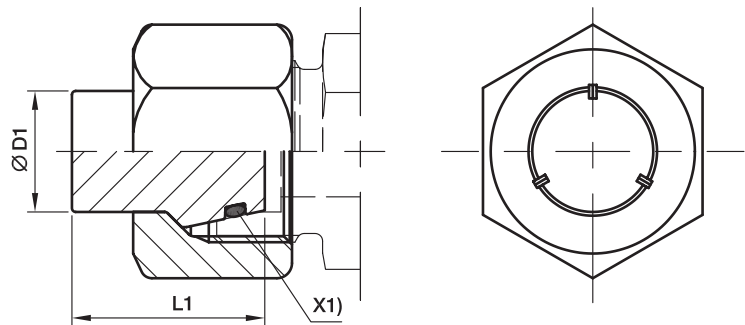

X1) O-ring OR

Series	D1 	L1	Weight g/1 piece	Order code*	PN (bar) ¹⁾	
					CF	71
L ³⁾	06	18.5	15	VKAM06L	500	315
	08	18.5	24	VKAM08L	500	315
	10	20.0	33	VKAM10L	500	315
	12	20.5	46	VKAM12L	400	315
	15	20.5	73	VKAM15L	400	315
	18	22.5	111	VKAM18L	400	315
	22	25.0	162	VKAM22L	250	160
	28	25.5	220	VKAM28L	250	160
	35	30.0	376	VKAM35L	250	160
S ⁴⁾	06	18.5	23	VKAM06S	800	630
	08	18.5	29	VKAM08S	800	630
	10	20.0	46	VKAM10S	800	630
	12	20.5	55	VKAM12S	630	630
	16	23.5	106	VKAM16S	630	400
	20	28.5	180	VKAM20S	420	400
	25	29.0	322	VKAM25S	420	400
	30	30.5	398	VKAM30S	420	400
	38	33.0	647	VKAM38S	420	315

¹⁾ Pressure shown = item deliverable

³⁾ L = light series; ⁴⁾ S = heavy series

$$\frac{\text{PN (bar)}}{10} = \text{PN (MPa)}$$

Information on ordering alternative sealing materials see page 17.

*Please add the **suffixes** below according to the material/surface required.

Order code suffixes			
Material	Suffix surface and material	Example	Standard sealing material (no additional suffix needed)
Steel, zinc plated, Cr(VI)-free	CF	VKAM16SCF	NBR
Stainless Steel	71	VKAM16S71	VIT

BUZ Blanking plug for cones

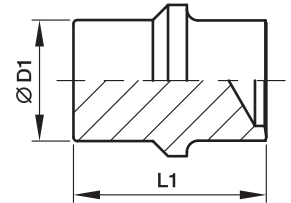

Series	D1 	L1	Weight g/1 piece	Order code*	PN (bar) ¹⁾		
					CF	71	MS
L ³⁾	06	19.5	5	BUZ06L	315	315	200
	08	19.5	8	BUZ08L	315	315	200
	10	21.0	13	BUZ10L	315	315	200
	12	21.8	20	BUZ12L	315	315	200
	15	22.0	30	BUZ15L	315	315	200
	18	24.0	45	BUZ18L	315	315	200
	22	26.0	74	BUZ22L	160	160	100
	28	26.5	117	BUZ28L	160	160	100
	35	32.0	217	BUZ35L	160	160	100
	42	32.5	308	BUZ42L	160	160	100
S ⁴⁾	06	19.5	5	BUZ06L	630	630	400
	08	19.5	8	BUZ08L	630	630	400
	10	21.0	13	BUZ10L	630	630	400
	12	21.8	20	BUZ12L	630	630	400
	16	25.5	39	BUZ16S	400	400	250
	20	30.5	73	BUZ20S	400	400	250
	25	32.5	119	BUZ25S	400	400	250
	30	35.5	181	BUZ30S	400	400	250
	38	40.0	325	BUZ38S	315	315	200

¹⁾ Pressure shown = item deliverable

³⁾ L = light series; ⁴⁾ S = heavy series

$$\frac{\text{PN (bar)}}{10} = \text{PN (MPa)}$$

*Please add the **suffixes** below according to the material/surface required.

Order code suffixes		
Material	Suffix surface and material	Example
Steel, zinc plated, Cr(VI)-free	CFX	BUZ16SCFX
Stainless Steel	71X	BUZ16S71X
Brass	MSX	BUZ16SMSX

BUZM Blanking plug with nut for cones

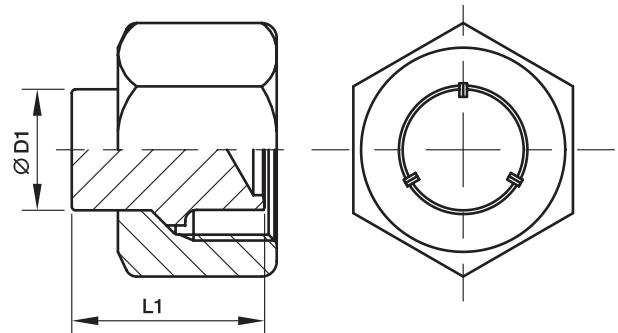

Series	D1 	L1	Weight g/1 piece	Order code*	PN (bar) ¹⁾	
					CF	71
L ³⁾	06	19.5	15	BUZM06L	315	315
	08	19.5	23	BUZM08L	315	315
	10	21.0	31	BUZM10L	315	315
	12	21.8	45	BUZM12L	315	315
	15	22.0	71	BUZM15L	315	315
	18	24.0	107	BUZM18L	315	315
	22	26.0	156	BUZM22L	160	160
	28	26.5	206	BUZM28L	160	160
	35	32.0	354	BUZM35L	160	160
	42	32.5	524	BUZM42L	160	160
S ⁴⁾	06	19.5	23	BUZM06S	630	630
	08	19.5	28	BUZM08S	630	630
	10	21.0	44	BUZM10S	630	630
	12	21.8	54	BUZM12S	630	630
	16	25.5	105	BUZM16S	400	400
	20	30.5	176	BUZM20S	400	400
	25	32.5	321	BUZM25S	400	400
	30	35.5	399	BUZM30S	400	400
	38	40.0	664	BUZM38S	315	315

¹⁾ Pressure shown = item deliverable

³⁾ L = light series; ⁴⁾ S = heavy series

PN (bar) = PN (MPa)
10

*Please add the **suffixes** below according to the material/surface required.

Order code suffixes		
Material	Suffix surface and material	Example
Steel, zinc plated, Cr(VI)-free	CF	BUZM16SCF
Stainless Steel	71	BUZM16S71

GM Locknut for bulk heads

For bulkhead SV and WSV

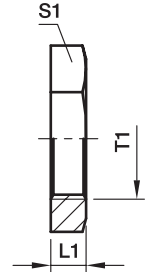

Series	Tube O.D.	T1	L1	S1	Weight g/1 piece	Order code		
						Steel CF	Stainless Steel 71	Brass MS
L ³⁾	06	M 12×1.5	6	17	7	GM06LCFX	GM06L71X	GM06LMSX
	08	M 14×1.5	6	19	8	GM08LCFX	GM08L71X	GM08LMSX
	10	M 16×1.5	6	22	11	GM10LCFX	GM10L71X	GM10LMSX
	12	M 18×1.5	6	24	12	GM12LCFX	GM12L71X	GM12LMSX
	15	M 22×1.5	7	30	23	GM15LCFX	GM15L71X	GM15LMSX
	18	M 26×1.5	8	36	37	GM18LCFX	GM18L71X	GM18LMSX
	22	M 30×2.0	8	41	46	GM22LCFX	GM22L71X	GM22LMSX
	28	M 36×2.0	9	46	58	GM28LCFX	GM28L71X	GM28LMSX
	35	M 45×2.0	9	55	71	GM35LCFX	GM35L71X	GM35LMSX
	42	M 52×2.0	10	65	123	GM42LCFX	GM42L71X	GM42LMSX
S ⁴⁾	06	M 14×1.5	6	19	8	GM08LCFX	GM08L71X	GM06LMSX
	08	M 16×1.5	6	22	11	GM10LCFX	GM10L71X	GM10LMSX
	10	M 18×1.5	6	24	12	GM12LCFX	GM12L71X	GM12LMSX
	12	M 20×1.5	6	27	15	GM12SCFX	GM12S71X	GM12SMSX
	16	M 24×1.5	7	32	24	GM16SCFX	GM16S71X	GM16SMSX
	20	M 30×2.0	8	41	46	GM22LCFX	GM22L71X	GM22LMSX
	25	M 36×2.0	9	46	58	GM28LCFX	GM28L71X	GM28LMSX
	30	M 42×2.0	9	50	58	GM30SCFX	GM30S71X	GM30SMSX
	38	M 52×2.0	10	65	123	GM42LCFX	GM42L71X	GM42LMSX

³⁾ L = light series; ⁴⁾ S = heavy series

VH Support sleeve

for thin-walled metal tubing

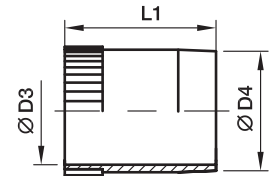

Tube I.D.	D3	D4	L1	Weight g/1 piece	Order code		
					Steel CF	Stainless Steel 71	Brass MS
4.00	2.6	3.8	14.0	0.7	VH04CFX	VH0471X	VH04MSX
4.50	3.1	4.3	14.0	0.8	VH04.5CFX	VH04.571X	VH04.5MSX
5.00	3.6	4.8	14.0	0.8	VH05CFX	VH0571X	VH05MSX
6.00	4.6	5.8	14.0	1.0	VH06CFX	VH0671X	VH06MSX
6.50	5.1	6.3	14.0	1.0	VH06.5CFX	VH06.571X	VH06.5MSX
7.00	5.6	6.8	15.5	1.3	VH07CFX	VH0771X	VH07MSX
8.00	6.6	7.8	15.5	1.6	VH08CFX	VH0871X	VH08MSX
9.00	7.6	8.8	15.5	1.8	VH09CFX	VH0971X	VH09MSX
10.00	8.6	9.8	15.5	2.1	VH10CFX	VH1071X	VH10MSX
10.05	8.6	9.8	15.5	2.1	VH10.05CFX	VH10.0571X	VH10.05MSX
10.50	9.1	10.3	15.5	2.3	VH10.5CFX	VH10.571X	VH10.5MSX
11.00	9.6	10.8	15.5	2.6	VH11CFX	VH1171X	VH11MSX
12.00	10.2	11.8	17.0	3.7	VH12CFX	VH1271X	VH12MSX
12.95	11.2	12.8	17.0	3.9	VH12.95CFX	VH12.9571X	VH12.95MSX
13.00	11.2	12.8	17.0	3.9	VH13CFX	VH1371X	VH13MSX
14.00	12.2	13.8	17.0	4.3	VH14CFX	VH1471X	VH14MSX
15.00	13.2	14.8	20.0	5.7	VH15CFX	VH1571X	VH15MSX
16.00	14.2	15.8	20.0	5.8	VH16.00CFX	VH16.0071X	VH16.00MSX
16.20	14.2	15.8	20.0	5.8	VH16CFX	VH1671X	VH16MSX
17.00	15.2	16.8	20.0	6.3	VH17CFX	VH1771X	VH17MSX
18.00	16.2	17.8	20.0	6.3	VH18CFX	VH1871X	VH18MSX
19.00	17.2	18.8	16.0	5.8	VH19CFX	VH1971X	VH19MSX
19.90	18.2	19.8	21.5	7.9	VH19.90CFX	VH19.9071X	VH19.90MSX
20.00	18.2	19.8	21.5	7.9	VH20CFX	VH2071X	VH20MSX
21.00	19.2	20.8	21.5	8.0	VH21CFX	VH2171X	VH21MSX
22.00	20.2	21.8	23.5	9.7	VH22CFX	VH2271X	VH22MSX
23.00	21.2	22.8	23.5	10.6	VH23CFX	VH2371X	VH23MSX
24.00	22.2	23.8	23.5	11.1	VH24CFX	VH2471X	VH24MSX
24.90	23.3	24.8	23.5	10.8	VH24.90CFX	VH24.9071X	VH2490MSX
25.00	23.2	24.8	23.5	10.8	VH25CFX	VH2571X	VH25MSX
26.00	24.2	25.8	23.5	12.7	VH26CFX	VH2671X	VH26MSX
27.00	25.2	26.8	23.5	12.2	VH27CFX	VH2771X	VH27MSX
30.00	27.8	29.8	26.5	18.7	VH30CFX	VH3071X	VH30MSX
31.00	28.8	30.8	26.5	20.7	VH31CFX	VH3171X	VH31MSX
32.00	29.8	31.8	26.5	19.2	VH32CFX	VH3271X	VH32MSX
32.10	29.8	31.8	26.5	19.2	VH32.10CFX	VH32.1071X	VH32.10MSX
33.00	30.8	32.8	26.5	19.9	VH33CFX	VH3371X	VH33MSX
34.00	31.8	33.8	26.5	26.5	VH34CFX	VH3471X	VH34MSX
37.80	35.8	37.7	31.0	19.5	VH37.8CFX	VH37.871X	VH37.8MSX
38.00	35.8	37.8	21.0	19.7	VH38CFX	VH3871X	VH38MSX
39.00	36.8	38.8	21.0	19.5	VH39CFX	VH3971X	VH39MSX

E Tube/hose insert

for plastic tubing

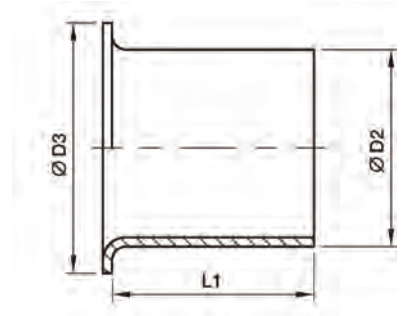

Tube O.D.	Tube I.D.	D2	D3	L1	Weight g/1 piece	Order code Brass
04	2.0	2.0	3.5	8	1	E04/02X
04	2.5	2.5	4.0	8	1	E04/2.5X
05	3.0	3.0	5.0	14	1	E0506/03X
06	3.0	3.0	5.0	14	1	E0506/03X
05	4.0	4.0	5.0	14	1	E0506/04X
06	4.0	4.0	5.0	14	1	E0506/04X
08	4.0	4.0	6.6	14	1	E08/04X
06	5.0	5.0	6.0	14	1	E06/05X
08	5.0	5.0	6.0	14	1	E08/05X
10	6.0	6.0	8.0	15	1	E0810/06X
08	6.0	6.0	8.0	15	1	E0810/06X
10	8.0	8.0	10.0	15	1	E10/08X
12	8.0	8.0	12.0	15	2	E12/08X
12	9.0	9.0	12.0	15	2	E12/09X
12	10.0	10.0	12.0	15	2	E1215/10X
15	12.0	12.0	14.8	15	3	E15/12X
15	12.5	12.5	14.8	15	3	E1516/12.5X
16	12.5	12.5	14.8	15	3	E1516/12.5X
18	14.0	14.0	17.8	15	4	E18/14X
18	16.0	16.0	17.8	20	4	E1820/16X
20	16.0	16.0	17.8	20	4	E1820/16X
22	18.0	18.0	21.8	16	5	E22/18X

DOZ EO-2 Soft sealing ring

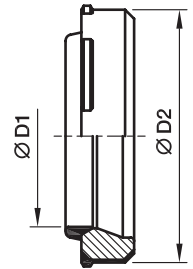

Assembly direction:
Sealing lip shows to the tube end

Series	D1 	D2	Weight g/1 piece	Order code			
				Steel NBR	Steel FKM	Stainless Steel FKM	Stainless Steel NBR
LL ²⁾	04	6.8	1	DOZ04LL	—	—	—
	06	8.8	1	DOZ06LL	—	—	—
L ³⁾	06	10.3	1	DOZ06L	DOZ06LVIT	DOZ06L71	DOZ06LNBR71
	08	12.3	1	DOZ08L	DOZ08LVIT	DOZ08L71	DOZ08LNBR71
	10	14.3	2	DOZ10L	DOZ10LVIT	DOZ10L71	DOZ10LNBR71
	12	16.3	2	DOZ12L	DOZ12LVIT	DOZ12L71	DOZ12LNBR71
	15	20.3	3	DOZ15L	DOZ15LVIT	DOZ15L71	DOZ15LNBR71
	18	24.3	5	DOZ18L	DOZ18LVIT	DOZ18L71	DOZ18LNBR71
	22	27.7	6	DOZ22L	DOZ22LVIT	DOZ22L71	DOZ22LNBR71
	28	33.7	7	DOZ28L	DOZ28LVIT	DOZ28L71	DOZ28LNBR71
	35	42.7	14	DOZ35L	DOZ35LVIT	DOZ35L71	DOZ35LNBR71
	42	49.7	17	DOZ42L	DOZ42LVIT	DOZ42L71	DOZ42LNBR71
S ⁴⁾	06	12.3	2	DOZ06S	DOZ06SVIT	DOZ06S71	DOZ06SNBR71
	08	14.3	2	DOZ08S	DOZ08SVIT	DOZ08S71	DOZ08SNBR71
	10	16.3	3	DOZ10S	DOZ10SVIT	DOZ10S71	DOZ10SNBR71
	12	18.3	4	DOZ12S	DOZ12SVIT	DOZ12S71	DOZ12SNBR71
	16	22.3	5	DOZ16S	DOZ16SVIT	DOZ16S71	DOZ16SNBR71
	20	27.7	9	DOZ20S	DOZ20SVIT	DOZ20S71	DOZ20SNBR71
	25	33.7	13	DOZ25S	DOZ25SVIT	DOZ25S71	DOZ25SNBR71
	30	39.7	18	DOZ30S	DOZ30SVIT	DOZ30S71	DOZ30SNBR71
38	49.7	27	DOZ38S	DOZ38SVIT	DOZ38S71	DOZ38SNBR71	

²⁾ LL = very light series; ³⁾ L = light series; ⁴⁾ S = heavy series

ED Eolastic soft seal (for BSPP and metric parallel threads)

For Type: GE...ED, EGE...ED, EVGE...ED, EW...ED, EV...ED, ET...ED, EL...ED,
VSTI...ED, RI...ED

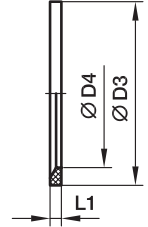

Male stud metric thread T1	Male stud BSP thread T1	D3	D4	L1	Weight g/1 piece	Order code NBR	Order code FKM
M 08×1.0		9.9	6.5	1.0	0.1	ED8X1X	ED8X1VITX
M 10×1.0	G 1/8 A	11.9	8.4	1.0	0.1	ED10X1X	ED10X1VITX
M 12×1.5		14.4	9.8	1.5	0.2	ED12X1.5X	ED12X1.5VITX
M 14×1.5	G 1/4 A	16.5	11.6	1.5	0.2	ED14X1.5X	ED14X1.5VITX
M 16×1.5		18.9	13.8	1.5	0.1	ED16X1.5X	ED16X1.5VITX
	G 3/8 A	18.9	14.7	1.5	0.2	ED3/8X	ED3/8VITX
M 18×1.5		20.9	15.7	1.5	0.1	ED18X1.5X	ED18X1.5VITX
M 20×1.5		22.9	17.8	1.5	0.2	ED20X1.5X	ED20X1.5VITX
	G 1/2 A	23.9	18.5	1.5	0.3	ED1/2X	ED1/2VITX
M 22×1.5		24.3	19.6	1.5	0.2	ED22X1.5X	ED22X1.5VITX
M 26×1.5	G 3/4 A	29.2	23.9	1.5	0.4	ED26X1.5X	ED26X1.5VITX
M 27×2.0	G 3/4 A	29.2	23.9	1.5	0.4	ED26X1.5X	ED26X1.5VITX
M 33×2.0	G 1 A	35.7	29.7	2.0	0.7	ED33X2X	ED33X2VITX
M 42×2.0	G 1 1/4 A	45.8	38.8	2.0	0.9	ED42X2X	ED42X2VITX
M 48×2.0	G 1 1/2 A	50.7	44.7	2.0	1.0	ED48X2X	ED48X2VITX

OR O-Ring for fittings with EO 24° DKO swivel

For Type:

DA, EGE, EGEO, MAVE, EW, EV, ET, EL, RED, GZ, GZR, VKA, VKAM

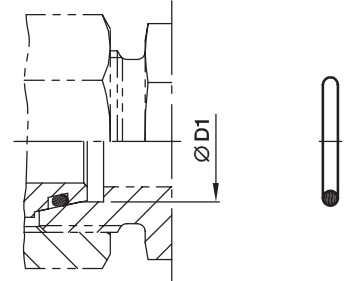

Series	D1 	O-ring NBR Shore-hardness approx. 90	O-ring FKM Shore-hardness approx. 90
L ³⁾	6	OR4.5X1.5X	OR4.5X1.5VITX
	8	OR6.5X1.5X	OR6.5X1.5VITX
	10	OR8.5X1.5X	OR8X1.5VITX
	12	OR10.5X1.5X	OR10X1.5VITX
	15	OR12.5X2X	OR12X2VITX
	18	OR16X2X	OR15X2VITX
	22	OR20X2X	OR20X2VITX
	28	OR26X2X	OR26X2VITX
	35	OR32X2.5X	OR32X2.5VITX
	42	OR39X2.5X	OR38X2.5VITX
S ⁴⁾	6	OR4.5X1.5X	OR4.5X1.5VITX
	8	OR6.5X1.5X	OR6.5X1.5VITX
	10	OR8.5X1.5X	OR8X1.5VITX
	12	OR10.5X1.5X	OR10X1.5VITX
	16	OR14X2X	OR13X2VITX
	20	OR17X2.5X	OR16.3X2.4VITX
	25	OR22X2.5X	OR20.3X2.4VITX
	30	OR27X2.5X	OR25.3X2.4VITX
	38	OR35X2.5X	OR33.3X2.4VITX

³⁾ L = light series; ⁴⁾ S = heavy series

OR O-rings for male stud ends

Male metric thread – O-ring (ISO 6149)
 Male UN/UNF thread – O-ring (ISO 11926)

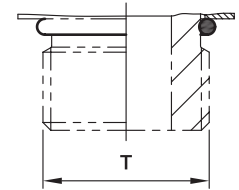

Types with metric thread:
 VSTI-OR, GEO, EGEO

Thread T	O-ring NBR	O-ring FKM
M 08×1.0	OR6.1X1.6	OR6.1X1.6VITX
M 10×1.0	OR8.1X1.6	OR8.1X1.6VITX
M 12×1.5	OR9.3X2.2	OR9.3X2.2VITX
M 14×1.5	OR11.3X2.2	OR11.3X2.2VITX
M 16×1.5	OR13.3X2.2	OR13.3X2.2VITX
M 18×1.5	OR15.3X2.2	OR15.3X2.2VITX
M 22×1.5	OR19.3X2.2	OR19.3X2.2VITX
M 27×2.0	OR23.6X2.9	OR23.6X2.9VITX
M 33×2.0	OR29.6X2.9	OR29.6X2.9VITX
M 42×2.0	OR38.6X2.9	OR38.6X2.9VITX
M 48×2.0	OR44.6X2.9	OR44.6X2.9VITX

Types with UN/UNF thread:
 GE-UNF

Thread T	O-ring NBR	O-ring FKM
7/16-20 UNF	OR8.92X1.83	OR8.92X1.83VITX
9/16-18 UNF	OR11.89X1.98	OR11.89X1.98VITX
3/4-16 UNF	OR16.36X2.21	OR16.36X2.21VITX
7/8-14 UNF	OR19.18X2.46	OR19X2.5VITX
1 1/16-12 UN	OR23.47X2.95	OR23.47X2.95VITX
1 5/16-12 UN	OR29.74X2.95	OR29.74X2.95VITX
1 5/8-12 UN	OR37.46X3	OR37.46X3VITX
1 7/8-12 UN	OR43.69X3	OR43.69X3VITX

OR O-rings and retaining rings for male stud ends

Adjustable BSPP thread – O-ring + retaining ring (ISO 1179)

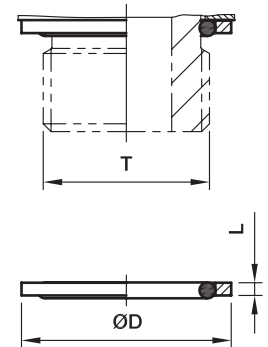

Types with BSPP thread: WEE-R

Thread T	O-ring NBR	Steel			O-ring FKM	Stainless Steel		
		D	L	Order code Retaining ring CF		D	L	Order code Retaining ring Stainless Steel
G 1/8 A	OR8X1.88X	14.8	1.4	RRS1/8CF	same like steel	15.0	1.4	8207SS1/8
G 1/4 A	OR10.77X2.62X	19.8	1.9	RRS1/4CF	OR10.77X2.62VITX	19.5	1.9	8207SS1/4A
G 3/8 A	OR13.94X2.62X	22.8	2.0	RRS3/8CF	same like steel	23.5	1.9	8207SS3/8A
G 1/2 A	OR18X3.15X	27.8	2.6	RRS1/2CF	OR17.96X2.62VITX	28.5	1.9	8207SS1/2
G 3/4 A	OR23X3X	32.8	2.5	RRS3/4CF	OR23.47X2.62VITX	34.5	1.9	8207SS3/4
G 1 A	OR29.74X3.53X	40.8	2.5	RRS1CF	same like steel	43.5	2.6	8207SS1A
G 1 1/4 A	OR37.69X3.53X	50.8	2.6	RRS11/4CF	same like steel	52.5	2.6	8207SS11/4
G 1 1/2 A	OR44.04X3.53X	55.8	2.6	RRS11/2CF	same like steel	60.0	2.6	8207SS11/2

Order code suffixes	
Material	Example
NBR	OR10.77X2.62X
FKM	OR10.77X2.62VITX

OR O-Rings for banjo fittings WH/TH

For WH / TH	For WH / TH	O-ring NBR	O-ring FKM
06LM/LR		OR9.3X1.5X	OR9.3X1.5VITX
08LM/LR	06SM/SR	OR12.5X1.5X	OR12.5X1.5VITX
10LM/LR	08SM/SR	OR12.5X1.5X	OR12.5X1.5VITX
12LM/LR	10SM/SR	OR16X1.5X	OR16X1.5VITX
	12SR	OR16X1.5X	OR16X1.5VITX
15LM	12SM	OR18X1.5X	OR18X1.5VITX
15LR		OR20X1.5X	OR20X1.5VITX
18LM/LR	16SM/SR	OR20X1.5X	OR20X1.5VITX
22LM/LR	20SM/SR	OR25X2X	OR25X2VITX
28LM/LR	25SM/SR	OR33X2.5X	OR33X2.5VITX
35LM/LR	30SM/SR	OR41X2.5X	OR41X2.5VITX
42LM/LR	38SM/SR	OR46X3X	OR46X3VITX

OR O-Rings for banjo elbows SWVE..M/R KDSOMD

For SWVE..M/R KDSOMD	O-ring NBR
04LLR/- 06LLR/LLM 08LLR/LLM 06LR/LM	OR9X1.2X
08LM 06SM	OR10X1.5X
08LR 06SR 10LR/LM 08SR/LM	OR12.5X1.5X
12LR/LM 10SR/LM 12SR	OR15X1.5X
15LM 12SM	OR16X1.5X
15LR	OR19X1.5X
18LR/LM 16SR/SM	OR20X1.5X
22LR/LM 20SR/SM	OR25.12X1.78X
28LR/LM 25SR/SM	OR33X2.5X
35LR/LM 30SR/SM	OR41X2.5X
42LR/LM 38SR/SM	OR46X3.0X

DKI Sealing ring for pressure gauge connectors

Female thread	D1	D2	L1	Weight g/1 piece	Order code	
					Steel CF	Stainless Steel 71
G 1/4	6	11.3	4.5	2.5	DKI1/4CFX	DKI1/471X
G 1/2	12	18.5	5.0	5.0	DKI1/2CFX	DKI1/271X

KDS Soft sealing ring for banjo fittings SWVE, WH and TH from steel

for small and wide spot faces of ports

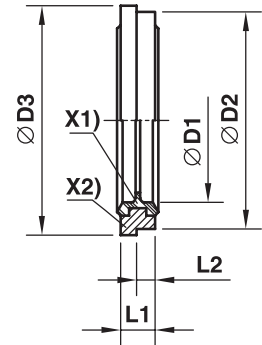

X1) NBR sealing
X2) Supporting-ring (Steel)

Male stud metric thread	Male stud BSPP thread	D1	D2	D3	L1	L2	Weight g/1 piece	Order code
								Steel/NBR
M 10×1.0	G 1/8 A	10.3	14.9	16.0	2.5	1.1	2	KDS10X
M 12×1.5		12.3	17.0	18.0	3.0	1.6	2	KDS12X
M 14×1.5	G 1/4 A	14.3	18.9	20.0	3.0	1.6	2	KDS14X
M 16×1.5	G 3/8 A	17.0	21.9	24.0	3.0	2.1	3	KDS16X
M 18×1.5		18.3	23.9	23.9	3.0		4	KDS18X
M 22×1.5	G 1/2 A	22.3	26.9	30.0	4.5	2.6	7	KDS22X
M 26×1.5		26.3	31.9	35.0	3.5	2.6	7	KDS26X
M 27×2.0	G 3/4 A	27.3	32.9	38.0	3.5	2.6	8	KDS27X
M 33×2.0	G 1 A	33.6	39.9	42.0	3.5	2.6	10	KDS33X
M 42×2.0	G 1 1/4 A	42.4	49.9	49.9	3.5		12	KDS42X
M 48×2.0	G 1 1/2 A	48.4	55.9	60.0	3.5	2.6	16	KDS48X

KD Soft sealing ring for banjo fittings WH/TH from stainless steel

for wide spot faces of ports

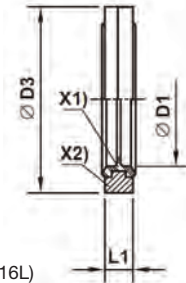

X1) Vulcanized FKM Seal
X2) Supporting-ring (Stainless Steel 316L)

Metric thread parallel	BSPP thread parallel	D1	D3	L1	Weight g/1 piece	Order code Stainless steel FKM
M 10×1.0	G 1/8 A	10.3	17.0	2.5	3	KD10-1/8SS
M 12×1.5		12.3	22.0	3.0	5	KD12SS
M 14×1.5	G 1/4 A	14.3	22.0	3.0	5	KD14-1/4SS
M 16×1.5	G 3/8 A	17.0	27.0	3.0	6	KD16-3/8SS
M 18×1.5		18.3	29.0	3.0	8	KD18SS
M 22×1.5	G 1/2 A	22.3	32.0	4.5	12	KD22-1/2SS
M 26×1.5		26.3	41.0	3.5	18	KD26SS
M 27×2.0	G 3/4 A	27.3	41.0	3.5	19	KD27-3/4SS
M 33×2.0	G 1 A	33.6	46.0	3.5	18	KD33-1SS
M 42×2.0	G 1 1/4 A	42.4	57.0	3.5	26	KD42-11/4SS
M 48×2.0	G 1 1/2 A	48.4	64.0	3.5	35	KD48-11/2SS

DKA Sealing ring

for banjo fittings WH/TH and SWVE

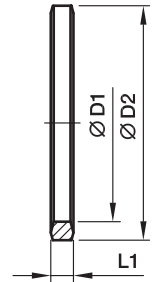

BSPP thread	D1	D2	L1	Weight g/1 piece	Order code	
					Steel CF	Stainless Steel 71
G 1/8 A	9.8	14	2.5	1	DKA1/8CFX	DKA1/871X
G 1/4 A	13.3	18	3.0	3	DKA1/4CFX	DKA1/471X
G 3/8 A	16.8	22	3.0	3	DKA3/8CFX	DKA3/871X
G 1/2 A	21.1	26	4.5	6	DKA1/2X4.5CFX	DKA1/2X4.571X
G 3/4 A	26.6	32	3.5	6	DKA3/4CFX	DKA3/471X
G 1 A	33.4	39	3.5	8	DKA1CFX	DKA171X
G 1 1/4 A	42.1	49	3.5	12	DKA11/4CFX	DKA11/471X
G 1 1/2 A	48.1	55	3.5	15	DKA11/2CFX	DKA11/271X







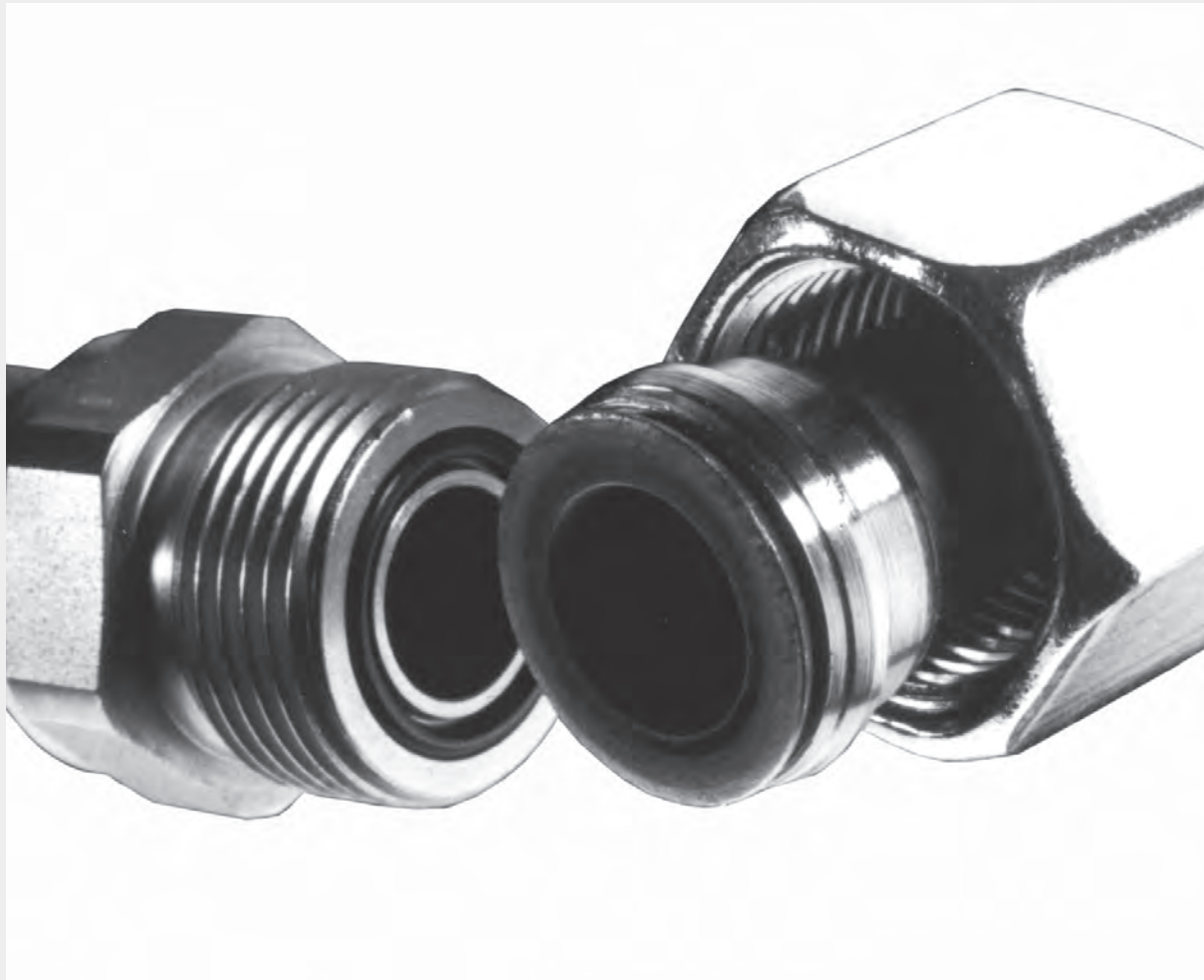



Male stud metric thread	D1	D2	L1	Weight g/1 piece	Order code	
					Steel CF	Stainless Steel 71
M 08×1.0	8.1	12	2.5	1	DKA08CFX	
M 10×1.0	10.1	14	3.0	1	DKA10CFX	DKA1071X
M 12×1.5	12.1	17	3.0	2	DKA12CFX	DKA1271X
M 14×1.5	14.1	19	3.0	3	DKA14CFX	DKA1471X
M 16×1.5	16.1	21	3.0	3	DKA16CFX	DKA1671X
M 18×1.5	18.1	23	3.0	3	DKA18CFX	DKA1871X
M 20×1.5	20.1	25	3.0	4	DKA20CFX	DKA2071X
M 22×1.5	22.1	27	4.5	6	DKA22X4.5CFX	DKA22X4.571X
M 26×1.5	26.1	31	3.5	6	DKA26X3.5CFX	DKA26X3.571X
M 27×2.0	27.1	32	3.5	6	DKA27CFX	DKA2771X
M 33×2.0	33.1	39	3.5	8	DKA33CFX	DKA3371X
M 42×2.0	42.1	49	3.5	12	DKA11/4CFX	DKA11/471X
M 48×2.0	48.1	55	3.5	15	DKA11/2CFX	DKA11/271X

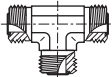
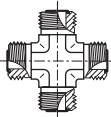
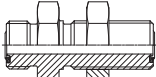
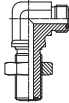
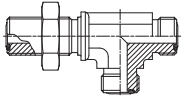
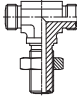
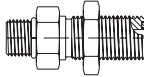
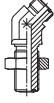

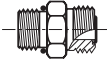
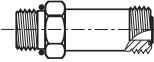
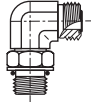

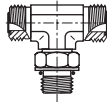
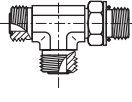
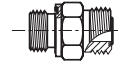
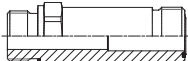
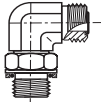

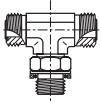
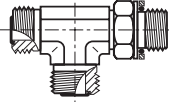
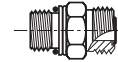
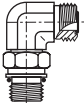
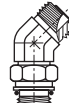
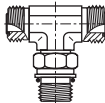
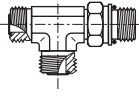
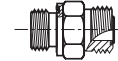
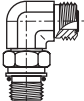
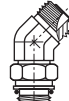
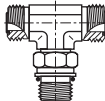
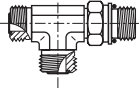
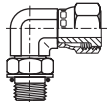
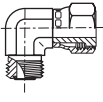

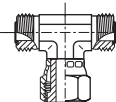
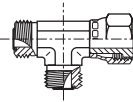



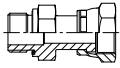
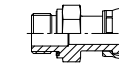

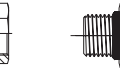

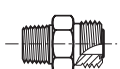

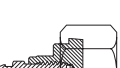











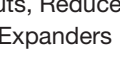

O-Lok[®]
O-Ring face seal tube fittings



Visual index

Tube-Tube unions							
	HMLO p. J9	EMLO p. J10	JMLO p. J11	KLO p. J12			
Bulkhead unions							
	WMLO p. J13	WEMLO p. J14	WJJLO p. J17	WJLO p. J16	WF5OLO p. J29	WNLO p. J15	WLNML p. J72
Tube to UNF thread							
	F5OMLO p. J27	FF5OMLO p. J28	C5OMLO p. J39	CC5OLO p. J40	V5OMLO p. J45	S5OMLO p. J49	R5OMLO p. J53
Tube to BSPP thread							
	F42EDMLO p. J30	FF42EDMLO p. J31	C4OMLO p. J41	V4OMLO p. J46	S4OMLO p. J50	R4OMLO p. J54	
Tube to metric ISO 6149-2 thread							
	F87OMLO p. J26	C87OMLO p. J38	V87OMLO p. J44	S87OMLO p. J48	R87OMLO p. J52		
Tube to metric thread							
	F82EDMLO p. J32	C8OMLO p. J42	V8OMLO p. J47	S8OMLO p. J51	R8OMLO p. J55		
Swivel fittings							
	AOEL6 p. J18	C6MLO p. J19	V6LO p. J20	S6MLO p. J21	R6MLO p. J22		

Visual index

Swivel nut to straight thread	 <p>BSPP F642EDML p. J36</p>	 <p>Metric F682EDML p. J37</p>	 <p>ISO Metric F687OML p. J34</p>	 <p>UNF F65OL p. J35</p>	 <p>HL6 p. J25</p>	
Tube to NPTF thread	 <p>FLO p. J33</p>	 <p>CLO p. J43</p>	<p>Taper threads should not be used for new projects or designs. Parker Hannifin recommends elastomerically sealed components.</p>			
Bleed adapters	 <p>FNLBA p. J69</p>	 <p>PNLOBA p. J70</p>	 <p>NPTF HPBA p. J71</p>	 <p>UNF P5ONBA p. J71</p>		
Test point and gauge adapters	 <p>TTP4ML p. J60</p>	 <p>R6P4MLO p. J61</p>	 <p>G4MLOSMO p. J57</p>	 <p>TT4ML p. J58</p>	 <p>TT8ML p. J59</p>	 <p>G87MLO p. J56</p>
Sleeves for metric and inch tube	 <p>TPL p. J6</p>	 <p>TL p. J7</p>	 <p>TL Reducing Braze Sleeve p. J8</p>	<p>Nuts, Reducers & Expanders</p>  <p>BML/BL p. J5</p>  <p>TRMLO p. J23</p>  <p>LOHL6 p. J24</p>		
Conversion adapters	 <p>XHML0 p. J65</p>	 <p>XHML6 p. J66</p>	 <p>LOHMX6 p. J67</p>	 <p>LOHU86 p. J68</p>		
Accessories	 <p>LOHB3 p. J62</p>	 <p>FNML p. J63</p>	 <p>PNML0 p. J64</p>	 <p>O-ring p. J73-74</p>	 <p>SBR Braze ring p. J75</p>	 <p>TW3L p. J72</p>

J

How to order O-Lok® fittings

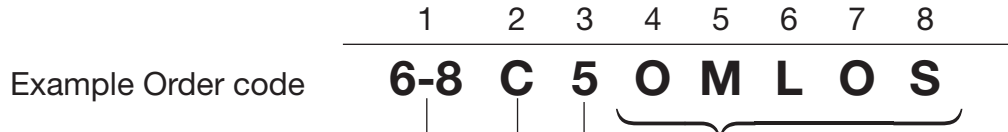

1 Order codes for tube and port thread ends

Dash Size	Tube Size (Inch)	Tube Size (mm)	O-Lok Tube Thread Size	Port Thread Size (Inch) BSPP/BSPT/NPT	Port Thread Size UN / UNF
4	1/4	6	9/16-18	1/4	7/16-20
5			5/8-18		1/2-20
6	3/8	8,10	11/16-16	3/8	9/16-18
8	1/2	12	13/16-16	1/2	3/4-16
10	5/8	14,15,16	1-14	5/8	7/8-14
12	3/4	18,20	1 3/16-12	3/4	1 1/6-12
14			1 5/16-12		1 3/6-12
16	1	25	1 7/16-12	1	1 5/16-12
20	1 1/4	28,30,32	1 11/16-12	1 1/4	1 5/8-12
24	1 1/2	35,38	2-12	1 1/2	1 7/8-12
32	2	50	2 1/2-12	2	2 1/2-12

Metric port threads are shown as per example 4M12C87OMLOS

3 Threads and sealing methods

Code	Description
None	NPT/NPTF Thread
3	BSPT Thread
4	BSPP Thread O-Ring & Retainer Ring
42	BSPP Thread EOLASTIC seal 'ED'
5	UN/UNF Thread (O-Ring Seal)
8	Metric Thread O-Ring & Retainer Ring
82	Metric Thread EOLASTIC seal 'ED'
87	Metric ISO 6149 Thread (O-Ring Seal)
63	Swivel Connector BSPT end
64	Swivel Connector BSPP end (O-Ring & Retainer Ring)
642	Swivel Connector BSPP end (EOLASTIC Seal 'ED')
65	Swivel Connector UN/UNF end (O-Ring seal)
68	Swivel Connector Metric end (O-Ring & Retainer Ring)
682	Swivel Connector Metric end (EOLASTIC Seal 'ED')
687	Swivel Connector Metric ISO 6149 end

2 Codes for fitting styles/shapes

Code	Description
AE6	Straight Thread Swivel
B	Nut
C	Male Stud elbow
C6	Swivel Nut Elbow
E	Union elbow
F	Male Stud connector
FF	Extended Male Stud connector
F6	Male Stud Swivel
FN	Cap
FNLBAS	Bleed Adapter Cap
G	Female Connector
H	Straight union
H6	Swivel/Swivel Adapter
J	Union Tee
K	Union Cross
LOHB3	Braze Adapter
LOHX6	Triple-Lok® Swivel/O-Lok® adaptor
M	Female Run Tee
O	Female Branch Tee
PN	Plug
PNLOBA	Bleed Adapter Plug
R	Male Stud Run Tee
R6	Swivel Run Tee
S	Male Stud Branch Tee
S6	Swivel Branch Tee
SBR	Braze Ring
TPL	Parflange® sleeve
TL	Brazed sleeve
TR	Tube End Reducer
TT	Test Point Adapter
TW3	Weld Nipple
V	45° male stud elbow
V6	Swivel Nut 45° Elbow
W	Bulkhead Union
WE	Bulkhead Union Elbow
WJJ	Bulkhead Run Tee
WJT	Bulkhead Branch Tee
WLNML	Bulkhead Locknut
WN	Bulkhead 45° union elbow
XHL6	Triple Lok®/Swivel O-Lok® adaptor
XHLO	Triple Lok®/O-Lok® male adaptor

4 Stud connector seal

Code	Description
O	O-Ring Seal (Assembled on fitting)
ED	Captive EOLASTIC Seal (Assembled on fitting)
No Code	No Seal (O-Ring not assembled on fitting)

5 Hexagon/ Across flats style

Code	Description
M	Metric Hexagon Dimension
No Code	Inch Hexagon Dimension

6 Fitting type

Code	Description
L	Parker O-Lok®

7 Tube connection seal ORFS

Code	Description
O	O-Ring Seal (Assembled on Fitting)
No Code	No Seal/O-Ring

8 Fitting material

Code	Description
S	Steel
SS	Stainless Steel
B	Brass

BML Nut

O-Lok® ORFS tube nut
SAE 52M0110 ISO 8434-3 NA

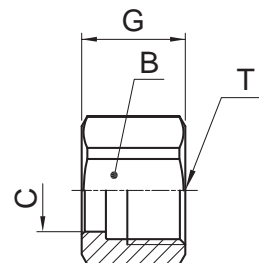

Tube O.D.		Thread UN/UNF-2B T	B mm	C mm	G mm	Weight (steel) g/1 piece	O-Lok® Steel	O-Lok® Stainless Steel
mm	in.							
6	1/4	9/16-18	17	10.5	15	14	4BMLS	4BMLSS
8, 10	3/8	11/16-16	22	13.5	18	17	6BMLS	6BMLSS
12	1/2	13/16-16	24	16.6	20	29	8BMLS	8BMLSS
14, 15, 16	5/8	1-14	30	21.1	24	46	10BMLS	10BMLSS
18, 20	3/4	1 3/16-12	36	24.2	27	69	12BMLS	12BMLSS
22, 25	1	1 7/16-12	41	29.1	28	109	16BMLS	16BMLSS
28, 30, 32	1 1/4	1 11/16-12	50	36.0	28	126	20BMLS	20BMLSS
35, 38	1 1/2	2-12	60	44.0	28	195	24BMLS	24BMLSS
50	2	2 1/2-12	75	56.0	33	800	32BMLS	32BMLSS

Part numbers shown are part of our current manufacturing programme.

Do not create drawings from these dimensions, they are subject to change and ISO manufacturing allowances.

BL Nut

O-Lok® ORFS tube nut
SAE 520110

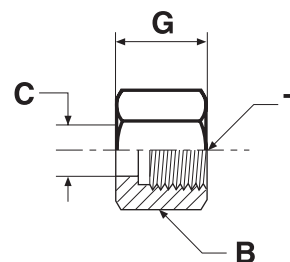

Tube O.D.		Thread UN/UNF-2B T	B in.	C mm	G mm	Weight (steel) g/1 piece	O-Lok® Steel	O-Lok® Stainless Steel
mm	in.							
6	1/4	9/16-18	11/16	10.5	15	16	4 BL-S	4 BL-SS
8, 10	3/8	11/16-16	13/16	13.5	17	24	6 BL-S	6 BL-SS
12	1/2	13/16-16	15/16	16.6	21	37	8 BL-S	8 BL-SS
14, 15, 16	5/8	1-14	1 1/8	22.1	24	52	10 BL-S	10 BL-SS
18, 20	3/4	1 3/16-12	1 3/8	24.1	26	89	12 BL-S	12 BL-SS
22, 25	1	1 7/16-12	1 5/8	29.1	28	119	16 BL-S	16 BL-SS
28, 30, 32	1 1/4	1 11/16-12	1 7/8	36.0	28	132	20 BL-S	20 BL-SS
35, 38	1 1/2	2-12	2 1/4	44.0	28	220	24 BL-S	24 BL-SS
50	2	2 1/2-12	2 7/8	56.0	33	700	32 BL-S	32 BL-SS

Part numbers shown are part of our current manufacturing programme.

Do not create drawings from these dimensions, they are subject to change and ISO manufacturing allowances.

TPL Sleeve metric tubing

O-Lok® ORFS Parflange® tube sleeve

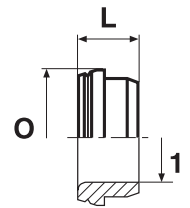

Tube O.D. 1 mm	L mm	O mm	Weight (steel) g/1 piece	O-Lok® Steel	O-Lok® Stainless Steel
6	8	13	4	TPLS6	TPLSS6
8	8	13	4	TPLS8-6	TPLSS8-6
8	9	16	4	TPLS8	TPLSS8
10	9	16	5	TPLS10	TPLSS10
10	11	19	6	TPLS12-10	TPLSS12-10
12	11	19	6	TPLS12	TPLSS12
14	11	23	10	TPLS14	TPLSS14
15	11	23	9	TPLS15	TPLSS15
16	11	23	8	TPLS16	TPLSS16
18	12	28	14	TPLS18	TPLSS18
20	12	28	15	TPLS20	TPLSS20
22	14	34	20	TPLS22	TPLSS22
25	13	34	23	TPLS25	TPLSS25
28	13	40	24	TPLS28	TPLSS28
30	13	40	25	TPLS30	TPLSS30
32	13	40	26	TPLS32	TPLSS32
35	13	48	36	TPLS35	TPLSS35
38	13	48	44	TPLS38	TPLSS38
50	14	61	180	TPLS50	TPLSS50

Part numbers shown are part of our current manufacturing programme.

Do not create drawings from these dimensions, they are subject to change and ISO manufacturing allowances.

TPL Sleeve inch tubing

O-Lok® ORFS Parflange® tube sleeve

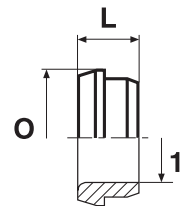

Tube O.D. 1 in.	L mm	O mm	Weight (steel) g/1 piece	O-Lok® Steel	O-Lok® Stainless Steel
1/4	8	13	4	4 TPL-S	4 TPL-SS
3/8	9	16	5	6 TPL-S	6 TPL-SS
1/2	11	19	6	8 TPL-S	8 TPL-SS
5/8	11	23	11	10 TPL-S	10 TPL-SS
3/4	12	28	19	12 TPL-S	12 TPL-SS
7/8	14	31	19	14 TPL-S	14 TPL-SS
1	14	34	22	16 TPL-S	16 TPL-SS
1 1/4	13	41	28	20 TPL-S	20 TPL-SS
1 1/2	13	48	44	24 TPL-S	24 TPL-SS
2	14	61	180	32 TPL-S	32 TPL-SS

Part numbers shown are part of our current manufacturing programme.

Do not create drawings from these dimensions, they are subject to change and ISO manufacturing allowances.

TL* Braze sleeve metric tubing

O-Lok® ORFS silver braze tube sleeve

SAE 52M0115 ISO 8434-3 BRSL

(*Parts delivered oil dipped finish only – steel)

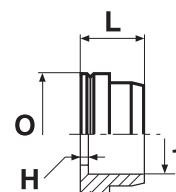

ORFS dash size	Tube O.D. 1 mm	H mm	L mm	O mm	Weight (steel) g/1 piece	O-Lok® Steel	O-Lok® Stainless Steel
4	6	1	10	13	5	TLS6	TLSS6
4	8	1	10	13	5	TLS6-8	TLSS6-8
5	8	1	10	16	7	TLS8	TLSS8
6	8	2	10	16	7	TLS10-8	TLSS10-8
6	10	1	10	16	7	TLS10	TLSS10
8	10	4	12	19	10	TLS12-10	TLSS12-10
8	12	1	10	19	10	TLS12	TLSS12
10	15	2	11	23	16	TLS16-15	TLSS16-15
10	16	2	11	23	16	TLS16	TLSS16
12	18	2	14	28	26	TLS20-18	TLSS20-18
12	20	2	14	28	21	TLS20	TLSS20
16	22	2	16	34	33	TLS25-22	TLSS25-22
16	25	2	16	34	30	TLS25	TLSS25
20	28	2	16	41	41	TLS32-28	TLSS32-28
20	30	2	16	41	42	TLS32-30	TLSS32-30
20	32	2	16	41	40	TLS32	TLSS32
24	35	2	16	49	48	TLS38-35	TLSS38-35
24	38	2	16	49	63	TLS38	TLSS38

Part numbers shown are part of our current manufacturing programme.

Do not create drawings from these dimensions, they are subject to change and ISO manufacturing allowances.

TL* Braze sleeve inch tubing

O-Lok® ORFS silver braze tube sleeve

SAE 520115

(*Parts delivered oil dipped finish only – steel)

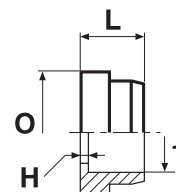

Tube O.D. 1 in.	H mm	L mm	O mm	Weight (steel) g/1 piece	O-Lok® Steel	O-Lok® Stainless Steel
1/4	1	10	13	5	4 TL-S	4 TL-SS
3/8	1	10	16	6	6 TL-S	6 TL-SS
1/2	1	10	19	10	8 TL-S	8 TL-SS
5/8	2	11	23	18	10 TL-S	10 TL-SS
3/4	2	14	28	26	12 TL-S	12 TL-SS
1	2	16	34	33	16 TL-S	16 TL-SS
1 1/4	2	16	41	42	20 TL-S	20 TL-SS
1 1/2	2	16	49	63	24 TL-S	24 TL-SS
2	2	17	61	210	32 TL-S	32 TL-SS

Part numbers shown are part of our current manufacturing programme.

Do not create drawings from these dimensions, they are subject to change and ISO manufacturing allowances.

TL* Reducing braze sleeve inch tubing

O-Lok® ORFS silver braze tube sleeve

SAE 520115

(*Parts delivered oil dipped finish only – steel)

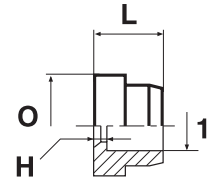

ORFS dash size	Tube O.D. 1 in.	H mm	L mm	O mm	Weight (Steel) g/1 piece	O-Lok® Steel	O-Lok® Stainless Steel
6	1/4	2	10	16	10	6-4 TL-S	6-4 TL-SS
8	1/4	4	12	19	17	8-4 TL-S	8-4 TL-SS
8	3/8	4	12	19	17	8-6 TL-S	8-6 TL-SS
10	1/4	5	14	23	37	10-4 TL-S	10-4 TL-SS
10	3/8	5	14	23	32	10-6 TL-S	10-6 TL-SS
10	1/2	5	14	23	28	10-8 TL-S	10-8 TL-SS
12	1/4	6	15	28	54	12-4 TL-S	12-4 TL-SS
12	3/8	6	15	28	49	12-6 TL-S	12-6 TL-SS
12	1/2	6	15	28	44	12-8 TL-S	12-8 TL-SS
12	5/8	6	15	28	39	12-10 TL-S	12-10 TL-SS
16	1/2	7	16	34	76	16-8 TL-S	16-8 TL-SS
16	5/8	7	16	34	71	16-10 TL-S	16-10 TL-SS
16	3/4	5	17	34	66	16-12 TL-S	16-12 TL-SS
16	7/8	5	17	34	50	16-14 TL-S	16-14 TL-SS
20	3/4	7	20	41	102	20-12 TL-S	20-12 TL-SS
20	1	7	21	41	79	20-16 TL-S	20-16 TL-SS
24	1	7	21	49	141	24-16 TL-S	24-16 TL-SS
24	1 1/4	7	21	49	107	24-20 TL-S	24-20 TL-SS

Part numbers shown are part of our current manufacturing programme.

Do not create drawings from these dimensions, they are subject to change and ISO manufacturing allowances.

HMLO Union

O-Lok® ORFS tube ends
SAE 520101

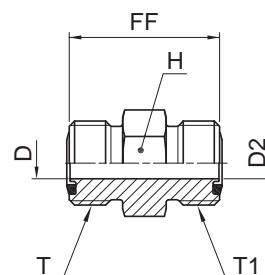

Tube 1 O.D.		Tube 2 O.D.		Thread UN/UNF-2A T	Thread UN/UNF-2A T1	D	D2	FF	H	Weight (steel) g/1 piece	O-Lok® Steel	O-Lok® Stainless Steel	PN (bar)	
mm	in.	mm	in.			mm	mm	mm	mm				S	SS
6	1/4	6	1/4	9/16-18	9/16-18	4.5	4.5	28	17	31	4HMLOS	4HMLOSS	630	630
8, 10	5/16, 3/8	8, 10	5/16, 3/8	11/16-16	11/16-16	6.5	6.5	31	19	49	6HMLOS	6HMLOSS	630	630
10	3/8	6	1/4	11/16-16	9/16-18	6.5	4.5	30	19	45	6-4HMLOS	6-4HMLOSS	630	630
12	1/2	12	1/2	13/16-16	13/16-16	9.5	9.5	36	22	77	8HMLOS	8HMLOSS	630	630
12	1/2	10	3/8	13/16-16	11/16-16	9.5	6.5	34	22	67	8-6 HLO-S	8-6HMLOSS	630	630
14, 15, 16	5/8	10	3/8	1-14	11/16-16	12.5	6.5	38	27	113	10-6HMLOS	10-6HMLOSS	420	420
14, 15, 16	5/8	14, 15, 16	5/8	1-14	1-14	12.5	12.5	43	27	129	10HMLOS	10HMLOSS	420	420
16	5/8	12	1/2	1-14	13/16-16	12.5	9.5	40	27	112	10-8 HLO-S	10-8HMLOSS	420	420
18, 20	3/4	12	1/2	1 3/16-12	13/16-16	15.5	9.5	43	32	160	12-8HMLOS	12-8HMLOSS	420	420
18, 20	3/4	18, 20	3/4	1 3/16-12	1 3/16-12	15.5	15.5	47	32	204	12HMLOS	12HMLOSS	420	420
20	3/4	16	5/8	1 3/16-12	1-14	15.5	12.5	46	32	186	12-10HMLOS	12-10HMLOSS	420	420
22, 25	1	22, 25	1	1 7/16-12	1 7/16-12	20.5	20.5	49	41	291	16HMLOS	16HMLOSS	420	420
25	1	18, 20	3/4	1 7/16-12	1 3/16-12	20.5	15.5	49	41	285	16-12HMLOS	16-12HMLOSS	420	420
28, 30, 32	1 1/4	28, 30, 32	1 1/4	1 11/16-12	1 11/16-12	26.0	26.0	51	45	299	20 HLO-S	20HMLOSS	420	280
28, 30, 32	1 1/4	22, 25	1	1 11/16-12	1 7/16-12	26.0	20.5	52	46	280	20-16HMLOS	20-16HMLOSS	420	280
35, 38	1 1/2	35, 38	1 1/2	2-12	2-12	32.0	32.0	53	54	552	24 HLO-S	24HMLOSS	350	280
35, 38	1 1/2	28, 30, 32	1 1/4	2-12	1 11/16-12	32.0	26.0	53	55	530	24-20HMLOS	24-20HMLOSS	350	280

Product delivered with NBR TRAP seal. Replacement of TRAP seal is with a standard NBR O-ring – see page J73-J74.

Part numbers shown are part of our current manufacturing programme.

Imperial and metric parts may vary in hexagon dimensions.

$$\frac{\text{PN (bar)}}{10} = \text{PN (MPa)}$$

Do not create drawings from these dimensions, they are subject to change and ISO manufacturing allowances.

J

EMLO Union elbow

O-Lok® ORFS tube ends
SAE 520201

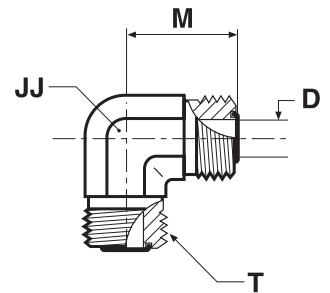

Tube O.D.		Thread UN/UNF-2A T	D mm	JJ* mm	M mm	Weight (steel) g/1 piece	O-Lok® Steel	O-Lok® Stainless Steel	PN (bar)	
mm	in.								S	SS
6	1/4	9/16-18	4.5	14	22	47	4 ELO-S	4EMLOSS	630	630
8, 10	5/16, 3/8	11/16-16	6.5	19	25	109	6 ELO-S	6EMLOSS	630	630
12	1/2	13/16-16	9.5	19	28	123	8 ELO-S	8EMLOSS	630	630
14, 15, 16	5/8	1-14	12.5	27	34	183	10 ELO-S	10EMLOSS	420	420
18, 20	3/4	1 3/16-12	15.5	30	38	255	12 ELO-S	12EMLOSS	420	420
22, 25	1	1 7/16-12	20.5	36	42	457	16 ELO-S	16EMLOSS	420	420
28, 30, 32	1 1/4	1 11/16-12	26.0	41	45	530	20 ELO-S	20EMLOSS	350	280
35, 38	1 1/2	2-12	32.0	48	49	687	24 ELO-S	24EMLOSS	280	280

Product delivered with NBR TRAP seal. Replacement of TRAP seal is with a standard NBR O-ring – see page J73-J74.

Part numbers shown are part of our current manufacturing programme.

Imperial and metric parts may vary in hexagon dimensions.

$$\frac{\text{PN (bar)}}{10} = \text{PN (MPa)}$$

Do not create drawings from these dimensions, they are subject to change and ISO manufacturing allowances.

*JJ may vary in stainless steel

JMLO Union tee

O-Lok® ORFS tube ends
SAE 520401

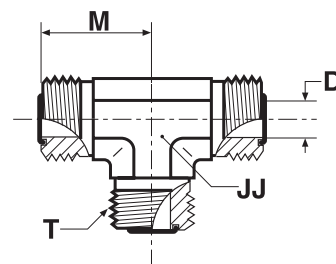

Tube O.D.		Thread UN/UNF-2A T	D mm	JJ* mm	M mm	Weight (steel) g/1 piece	O-Lok® Steel	O-Lok® Stainless Steel	PN (bar)	
mm	in.								S	SS
6	1/4	9/16-18	4.5	14	22	66	4JMLOS	4JMLOSS	630	630
8, 10	5/16, 3/8	11/16-16	6.5	19	25	114	6JMLOS	6JMLOSS	630	630
12	1/2	13/16-16	9.5	19	28	199	8JMLOS	8JMLOSS	630	630
14, 15, 16	5/8	1-14	12.5	27	34	239	10 JLO-S	10JMLOSS	420	420
18, 20	3/4	1 3/16-12	15.5	30	38	321	12 JLO-S	12JMLOSS	420	420
22, 25	1	1 7/16-12	20.5	36	42	488	16 JLO-S	16JMLOSS	420	420
28, 30, 32	1 1/4	1 11/16-12	26.0	41	45	768	20 JLO-S	20JMLOSS	350	280
35, 38	1 1/2	2-12	32.0	48	49	866	24 JLO-S	24JMLOSS	280	280

Product delivered with NBR TRAP seal. Replacement of TRAP seal is with a standard NBR O-ring – see page J73-J74.

Part numbers shown are part of our current manufacturing programme.

Imperial and metric parts may vary in hexagon dimensions.

$$\frac{\text{PN (bar)}}{10} = \text{PN (MPa)}$$

Do not create drawings from these dimensions, they are subject to change and ISO manufacturing allowances.

*JJ may vary in stainless steel

KLO Union cross

O-Lok® ORFS tube ends
SAE 520501

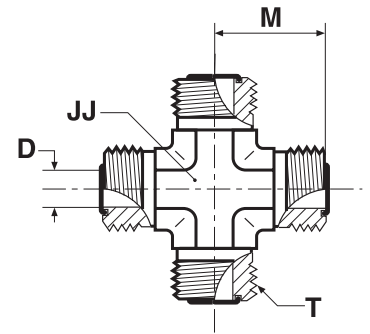

Tube O.D.		Thread UN/UNF-2A T	D mm	JJ* mm	M mm	Weight (steel) g/1 piece	O-Lok® Steel	O-Lok® Stainless Steel	PN (bar)	
mm	in.								S	SS
6	1/4	9/16-18	4.5	14	22	72	4 KLO-S	4 KLO-SS	630	630
8, 10	5/16, 3/8	11/16-16	6.5	19	25	140	6 KLO-S	6 KLO-SS	630	630
12	1/2	13/16-16	9.5	19	28	225	8 KLO-S	8 KLO-SS	630	630
14, 15, 16	5/8	1-14	12.5	27	33	288	10 KLO-S	10 KLO-SS	420	420
18, 20	3/4	1 3/16-12	15.5	30	37	415	12 KLO-S	12 KLO-SS	420	420
22, 25	1	1 7/16-12	20.5	41	42	967	16 KLO-S	16 KLO-SS	420	420
28, 30, 32	1 1/4	1 11/16-12	26.0	41	45	1247	20 KLO-S	20 KLO-SS	350	280
35, 38	1 1/2	2-12	32.0	48	49	1592	24 KLO-S	24 KLO-SS	280	280

Product delivered with NBR TRAP seal. Replacement of TRAP seal is with a standard NBR O-ring – see page J73-J74.

Part numbers shown are part of our current manufacturing programme.

Imperial and metric parts may vary in hexagon dimensions.

$$\frac{\text{PN (bar)}}{10} = \text{PN (MPa)}$$

Do not create drawings from these dimensions, they are subject to change and ISO manufacturing allowances.

*JJ may vary in stainless steel

WMLO Bulkhead union

O-Lok® ORFS tube ends
SAE 520601 ISO 8434-3 BHS

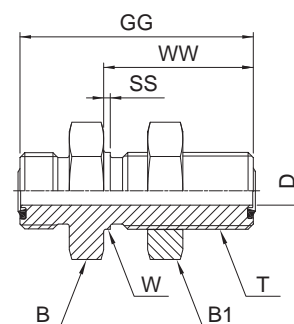

Tube O.D.		Thread UN/UNF-2A T	B1 mm	B mm	D mm	GG mm	SS mm	W mm	WW mm	Weight (steel) g/1 piece	O-Lok® Steel	O-Lok® Stainless Steel	PN (bar)	
mm	in.												S	SS
6	1/4	9/16-18	20.6	21	4.5	48	2	14	32	65	4 WLO-WLNL-S	4WMLOWLNLSS	630	630
8, 10	5/16, 3/8	11/16-16	27.0	27	6.5	53	2	17	34	104	6WMLOWLNLSS	6WMLOWLNLSS	630	630
12	1/2	13/16-16	30.0	30	9.5	59	3	21	37	141	8WMLOWLNLSS	8WMLOWLNLSS	630	630
14, 15, 16	5/8	1-14	36.0	32	12.5	67	3	25	41	285	10WMLOWLNLSS	10WMLOWLNLSS	420	420
18, 20	3/4	1 3/16-12	41.0	41	15.5	69	3	30	42	322	12WMLOWLNLSS	12WMLOWLNLSS	420	420
22, 25	1	1 7/16-12	44.5	45	20.5	70	2	36	42	480	16 WLO-WLNL-S	16WMLOWLNLSS	420	420
28, 30, 32	1 1/4	1 11/16-12	50.4	51	26.0	70	2	43	42	510	20 WLO-WLNL-S	20WMLOWLNLSS	420	280
35, 38	1 1/2	2-12	60.3	60	32.0	70	2	51	42	674	24 WLO-WLNL-S	24WMLOWLNLSS	350	280

Product delivered with NBR TRAP seal. Replacement of TRAP seal is with a standard NBR O-ring – see page J73-J74.

Part numbers shown are part of our current manufacturing programme.

Imperial and metric parts may vary in hexagon dimensions.

For the version without the locknut remove “WLNL” (e.g. 16WMLO)

$$\frac{\text{PN (bar)}}{10} = \text{PN (MPa)}$$

Do not create drawings from these dimensions, they are subject to change and ISO manufacturing allowances.

Maximum bulkhead wallthickness

Size	Tube O.D.		Straight bulkhead union Max. thickness mm	Shape bulkhead union Max. thickness mm
	inch	metric		
4	1/4	6	13.5	13.5
6	3/8	10	13.5	13.5
8	1/2	12	13.5	13.5
10	5/8	14-16	13.2	13.2
12	3/4	18-20	12.7	12.7
16	1	22-25	13.0	13.0
20	1 1/4	28-32	13.0	13.0
24	1 1/2	35-38	13.0	13.0

WEMLO Bulkhead union elbow

O-Lok® ORFS tube end/O-Lok® ORFS tube end
SAE520701/SAE 520701 ISO 8434-3 BHE

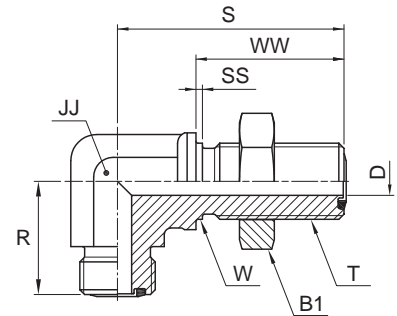

Tube O.D.		Thread UN/UNF-2A T	B1 mm	D mm	JJ* mm	R mm	S mm	SS mm	W mm	WW mm	Weight (steel) g/1 piece	O-Lok®		PN (bar)	
mm	in.											Steel	Stainless Steel	S	SS
6	1/4	9/16-18	20.6	4.5	14	23	47	2	14	32	78	4 WELO-WLNL-S	4 WELO-WLNL-SS	630	630
8, 10	5/16, 3/8	11/16-16	27.0	6.5	19	26	52	2	17	34	146	6WEMLOWLNMLS	6 WELO-WLNL-SS	630	630
12	1/2	13/16-16	30.0	9.5	19	29	56	3	21	37	252	8WEMLOWLNMLS	8 WELO-WLNL-SS	630	630
14, 15, 16	5/8	1-14	36.0	12.5	27	35	63	3	25	41	287	10WEMLOWLNMLS	10 WELO-WLNL-SS	420	420
18, 20	3/4	1 3/16-12	38.0	15.5	30	39	67	2	30	42	445	12 WELO-WLNL-S	12 WELO-WLNL-SS	420	420
22, 25	1	1 7/16-12	44.5	20.5	36	42	71	2	37	42	639	16 WELO-WLNL-S	16 WELO-WLNL-SS	420	420
28, 30, 32	1 1/4	1 11/16-12	50.4	26.0	41	46	75	2	43	42	718	20 WELO-WLNL-S	20 WELO-WLNL-SS	350	280
35, 38	1 1/2	2-12	60.3	32.0	48	50	80	2	51	42	945	24 WELO-WLNL-S	24 WELO-WLNL-SS	280	280

Product delivered with NBR TRAP seal. Replacement of TRAP seal is with a standard NBR O-ring – see page J73-J74.

Part numbers shown are part of our current manufacturing programme.

Imperial and metric parts may vary in hexagon dimensions.

For the version without the locknut remove “WLNML” (e.g. 16WEMLO)

$$\frac{PN \text{ (bar)}}{10} = PN \text{ (MPa)}$$

Do not create drawings from these dimensions, they are subject to change and ISO manufacturing allowances.
*JJ may vary in stainless steel

Maximum bulkhead wallthickness

Size	Tube O.D.		Straight bulkhead union Max. thickness mm	Shape bulkhead union Max. thickness mm
	inch	metric		
4	1/4	6	13.5	13.5
6	3/8	10	13.5	13.5
8	1/2	12	13.5	13.5
10	5/8	14-16	13.2	13.2
12	3/4	18-20	12.7	12.7
16	1	22-25	13.0	13.0
20	1 1/4	28-32	13.0	13.0
24	1 1/2	35-38	13.0	13.0

WNLO Bulkhead union 45° elbow

O-Lok® ORFS tube ends
SAE 520801 ISO 8434-3 BHE 45

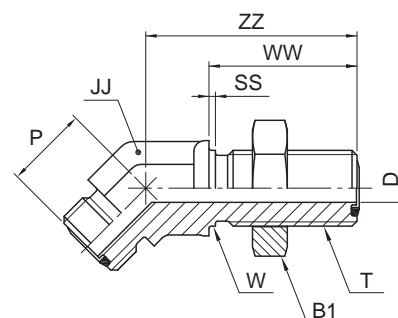

Tube O.D.		Thread UN/UNF-2A T	B1 mm	D mm	JJ* mm	P mm	SS mm	W mm	WW mm	ZZ mm	Weight (steel) g/1 piece	O-Lok® Steel	PN (bar)
mm	in.												
6	1/4	9/16-18	20.6	4.5	14	16	2	14	32	44	65	4 WNLO-WLNL-S	630
8, 10	5/16, 3/8	11/16-16	25.4	6.5	19	19	2	17	34	49	123	6 WNLO-WLNL-S	630
12	1/2	13/16-16	28.6	9.5	19	21	2	21	37	51	163	8 WNLO-WLNL-S	630
14, 15, 16	5/8	1-14	33.3	12.5	27	24	2	25	41	57	252	10 WNLO-WLNL-S	420
18, 20	3/4	1 3/16-12	38.0	15.5	30	26	2	30	42	61	386	12 WNLO-WLNL-S	420
22, 25	1	1 7/16-12	44.5	20.5	36	30	2	37	42	65	465	16 WNLO-WLNL-S	420
28, 30, 32	1 1/4	1 11/16-12	50.4	26.0	41	32	2	43	42	67	578	20 WNLO-WLNL-S	350
35, 38	1 1/2	2-12	60.3	32.0	48	37	2	51	42	67	770	24 WNLO-WLNL-S	280

Product delivered with NBR TRAP seal. Replacement of TRAP seal is with a standard NBR O-ring – see page J73-J74.

Part numbers shown are part of our current manufacturing programme.

Imperial and metric parts may vary in hexagon dimensions.

For the version without the locknut remove “WLNL” (e.g. 16 WNLO)

$$\frac{\text{PN (bar)}}{10} = \text{PN (MPa)}$$

Do not create drawings from these dimensions, they are subject to change and ISO manufacturing allowances.

*JJ may vary in stainless steel

Maximum bulkhead wallthickness

Size	Tube O.D.		Straight bulkhead union Max. thickness mm	Shape bulkhead union Max. thickness mm
	inch	metric		
4	1/4	6	13.5	13.5
6	3/8	10	13.5	13.5
8	1/2	12	13.5	13.5
10	5/8	14-16	13.2	13.2
12	3/4	18-20	12.7	12.7
16	1	22-25	13.0	13.0
20	1 1/4	28-32	13.0	13.0
24	1 1/2	35-38	13.0	13.0

WJLO Bulkhead branch tee

O-Lok® ORFS tube ends

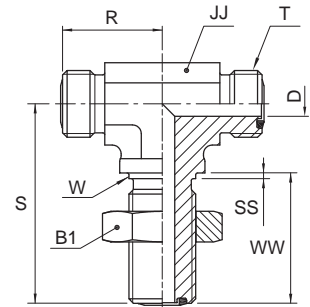

Tube O.D.		Thread UN/UNF-2A T	B1 mm	D mm	JJ* mm	R mm	S mm	SS mm	W mm	WW mm	Weight (steel) g/1 piece	O-Lok® Steel	PN (bar)
mm	in.												
6	1/4	9/16-18	20.6	4.5	14	23	47	2	14	32	100	4 WJLO-WLNL-S	630
8, 10	5/16, 3/8	11/16-16	25.4	6.5	19	26	52	2	18	34	178	6 WJLO-WLNL-S	630
12	1/2	13/16-16	28.6	9.5	19	29	55	2	21	37	270	8 WJLO-WLNL-S	630
14, 15, 16	5/8	1-14	33.3	12.5	27	35	63	2	25	41	370	10 WJLO-WLNL-S	420
18, 20	3/4	1 3/16-12	38.0	15.5	30	39	67	2	30	42	520	12 WJLO-WLNL-S	420
22, 25	1	1 7/16-12	44.5	20.5	36	42	71	2	37	42	680	16 WJLO-WLNL-S	420

Product delivered with NBR TRAP seal. Replacement of TRAP seal is with a standard NBR O-ring – see page J73-J74.

Part numbers shown are part of our current manufacturing programme.

Imperial and metric parts may vary in hexagon dimensions.

For the version without the locknut remove “WLNL” (e.g. 16 WJLO)

$$\frac{PN \text{ (bar)}}{10} = PN \text{ (MPa)}$$

Do not create drawings from these dimensions, they are subject to change and ISO manufacturing allowances.

*JJ may vary in stainless steel

Maximum bulkhead wallthickness

Size	Tube O.D.		Straight bulkhead union Max. thickness mm	Shape bulkhead union Max. thickness mm
	inch	metric		
4	1/4	6	13.5	13.5
6	3/8	10	13.5	13.5
8	1/2	12	13.5	13.5
10	5/8	14-16	13.2	13.2
12	3/4	18-20	12.7	12.7
16	1	22-25	13.0	13.0
20	1 1/4	28-32	13.0	13.0
24	1 1/2	35-38	13.0	13.0

WJJLO Bulkhead run tee

O-Lok® ORFS tube ends
SAE 520958 ISO 8434-3 BHRT

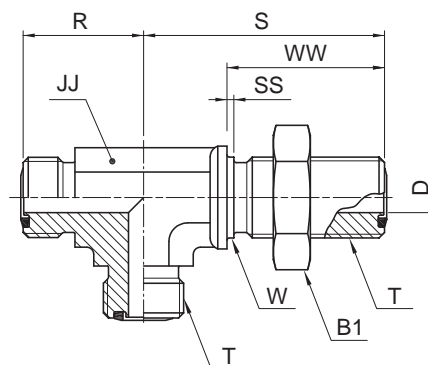

Tube O.D.		Thread UN/UNF-2A T	B1 mm	D mm	JJ* mm	R mm	S mm	SS mm	W mm	WW mm	Weight (steel) g/1 piece	O-Lok® Steel	PN (bar)
mm	in.												
6	1/4	9/16-18	20.6	4.5	14	23	46	2	14	32	99	4 WJJLO-WLNL-S	630
8, 10	5/16, 3/8	11/16-16	25.4	6.5	19	26	52	2	17	34	178	6 WJJLO-WLNL-S	630
12	1/2	13/16-16	28.6	9.5	19	29	55	2	21	37	270	8 WJJLO-WLNL-S	630
14, 15, 16	5/8	1-14	33.3	12.5	27	35	63	2	25	41	368	10 WJJLO-WLNL-S	420
18, 20	3/4	1 3/16-12	38.0	15.5	30	39	67	2	30	42	516	12 WJJLO-WLNL-S	420
22, 25	1	1 7/16-12	44.5	20.5	36	42	71	2	37	42	678	16 WJJLO-WLNL-S	420
28, 30, 32	1 1/4	1 11/16-12	50.4	26.0	41	46	71	2	43	42	980	20 WJJLO-WLNL-S	350
35, 38	1 1/2	2-12	60.3	32.0	48	50	80	2	51	42	1900	24 WJJLO-WLNL-S	280

Product delivered with NBR TRAP seal. Replacement of TRAP seal is with a standard NBR O-ring – see page J73-J74.

Part numbers shown are part of our current manufacturing programme.

Imperial and metric parts may vary in hexagon dimensions.

For the version without the locknut remove “WLNL” (e.g. 16 WJJLO)

$$\frac{\text{PN (bar)}}{10} = \text{PN (MPa)}$$

Do not create drawings from these dimensions, they are subject to change and ISO manufacturing allowances.

*JJ may vary in stainless steel

Maximum bulkhead wallthickness

Size	Tube O.D.		Straight bulkhead union Max. thickness mm	Shape bulkhead union Max. thickness mm
	inch	metric		
4	1/4	6	13.5	13.5
6	3/8	10	13.5	13.5
8	1/2	12	13.5	13.5
10	5/8	14-16	13.2	13.2
12	3/4	18-20	12.7	12.7
16	1	22-25	13.0	13.0
20	1 1/4	28-32	13.0	13.0
24	1 1/2	35-38	13.0	13.0

AOEL6 Swivel nut stud elbow

O-Lok® ORFS Female swivel end / Male UN/UNF thread – O-ring (ISO 11926)
SAE 520281

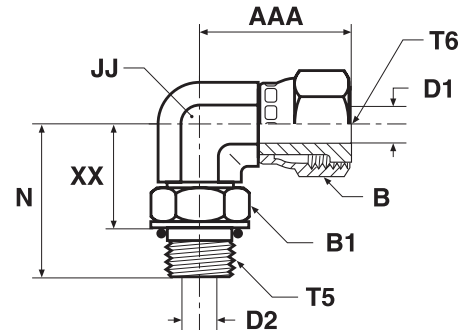

Tube O.D.		Thread UN/UNF-2A T5	Thread UN/UNF-2B T6	AAA	B	B1	D1	D2	JJ*	N	XX	Weight (steel)	O-Lok® Steel	O-Lok® Stainless Steel	PN (bar)	
mm	in.			mm	mm	mm	mm	mm	mm	mm	mm	g/1 piece			S	SS
6	1/4	7/16-20	9/16-18	26	18	14	4.0	4.5	14	33	22	47	4 AOEL6-S	4 AOEL6-SS	420	420
8, 10	5/16, 3/8	9/16-18	11/16-16	30	21	19	6.5	7.5	19	37	25	97	6 AOEL6-S	6 AOEL6-SS	420	420
12	1/2	3/4-16	13/16-16	38	24	24	9.0	10.0	19	41	27	104	8 AOEL6-S	8 AOEL6-SS	420	420
14, 15, 16	5/8	7/8-14	1-14	42	29	27	11.5	12.5	27	50	34	199	10 AOEL6-S	10 AOEL6-SS	420	420
18, 20	3/4	1 1/16-12	1 3/16-12	46	35	35	14.0	15.5	27	55	37	162	12 AOEL6-S	12 AOEL6-SS	420	420
22, 25	1	1 5/16-12	1 7/16-12	53	41	41	20.0	21.5	33	60	42	365	16 AOEL6-S	16 AOEL6-SS	380	380
28, 30, 32	1 1/4	1 5/8-12	1 11/16-12	58	48	48	26.0	27.5	41	62	44	480	20 AOEL6-S	20 AOEL6-SS	280	280
35, 38	1 1/2	1 7/8-12	2-12	61	57	54	32.0	33.5	50	66	47	933	24 AOEL6-S	24 AOEL6-SS	280	280

O-Lok® is delivered with NBR elastomeric seals as standard. For more details on other seal materials see page J73-J74.

Part numbers shown are part of our current manufacturing programme.

Imperial and metric parts may vary in hexagon dimensions.

$$\frac{\text{PN (bar)}}{10} = \text{PN (MPa)}$$

Do not create drawings from these dimensions, they are subject to change and ISO manufacturing allowances.

*JJ may vary in stainless steel

C6MLO Swivel nut elbow

O-Lok® ORFS Female swivel end / O-Lok® ORFS tube end
SAE 52M0221 ISO 8434-3 SWE

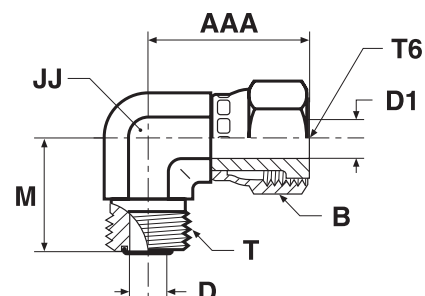

Tube O.D.		Thread UN/UNF-2A T	Thread UN/UNF-2B T6	AAA mm	B mm	D mm	D1 mm	JJ* mm	M mm	Weight (steel) g/1 piece	O-Lok® Steel	O-Lok® Stainless Steel	PN (bar)	
mm	in.												S	SS
6	1/4	9/16-18	9/16-18	26	17	4.5	4.0	14	22	45	4C6MLOS	4C6MLOSS	500	420
8, 10	5/16, 3/8	11/16-16	11/16-16	29	22	6.5	6.5	19	25	84	6C6MLOS	6C6MLOSS	630	420
12	1/2	13/16-16	13/16-16	38	24	9.5	9.0	19	28	126	8C6MLOS	8C6MLOSS	630	420
14, 15, 16	5/8	1-14	1-14	41	30	12.5	11.5	27	33	221	10C6MLOS	10C6MLOSS	420	420
18, 20	3/4	1 3/16-12	1 3/16-12	46	36	15.5	14.0	30	37	284	12C6MLOS	12C6MLOSS	420	420
22, 25	1	1 7/16-12	1 7/16-12	53	41	20.5	20.0	36	42	541	16C6MLOS	16C6MLOSS	420	420
28, 30, 32	1 1/4	1 11/16-12	1 11/16-12	58	48	26.0	26.0	41	45	557	20 C6LO-S	20C6MLOSS	350	280
35, 38	1 1/2	2-12	2-12	61	57	32.0	32.0	48	49	706	24 C6LO-S	24C6MLOSS	280	280

Product delivered with NBR TRAP seal. Replacement of TRAP seal is with a standard NBR O-ring – see page J73-J74.

Part numbers shown are part of our current manufacturing programme.

Imperial and metric parts may vary in hexagon dimensions.

$$\frac{\text{PN (bar)}}{10} = \text{PN (MPa)}$$

Do not create drawings from these dimensions, they are subject to change and ISO manufacturing allowances.

*JJ may vary in stainless steel

J

V6LO 45° Swivel nut elbow

O-Lok® ORFS female swivel end / O-Lok® ORFS tube end

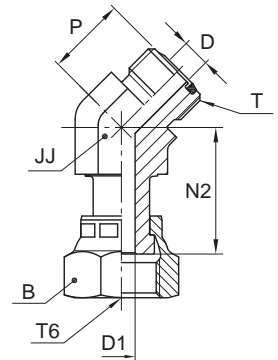

*JJ – Across wrench flats

Tube O.D.		Thread UN/UNF-2A T	Thread UN/UNF-2B T6	B mm	D mm	D1 mm	JJ* mm	N2 mm	P mm	Weight (steel) g/1 piece	O-Lok® Steel	PN (bar)
mm	in.											
6	1/4	9/16-18	9/16-18	18	4.5	4.0	14	25	16	44	4 V6LO-S	500
8, 10	5/16, 3/8	11/16-16	11/16-16	22	6.5	6.5	19	30	19	96	6V6MLOS	630
12	1/2	13/16-16	13/16-16	24	9.5	9.0	19	38	20	110	8 V6LO-S	630
14, 15, 16	5/8	1-14	1-14	30	12.5	11.5	27	42	23	235	10V6MLOS	420
18, 20	3/4	1 3/16-12	1 3/16-12	36	15.5	14.0	30	46	26	349	12V6MLOS	420
22, 25	1	1 7/16-12	1 7/16-12	41	20.5	20.0	36	48	30	300	16 V6LO-S	420
28, 30, 32	1 1/4	1 11/16-12	1 11/16-12	48	26.0	26.0	41	50	32	444	20 V6LO-S	350
35, 38	1 1/2	2-12	2-12	57	32.0	32.0	48	52	37	568	24 V6LO-S	280

Product delivered with NBR TRAP seal. Replacement of TRAP seal is with a standard NBR O-ring – see page J73-J74.

Part numbers shown are part of our current manufacturing programme.

Imperial and metric parts may vary in hexagon dimensions.

$$\frac{\text{PN (bar)}}{10} = \text{PN (MPa)}$$

Do not create drawings from these dimensions, they are subject to change and ISO manufacturing allowances.

*JJ may vary in stainless steel

S6MLO Swivel nut branch tee

O-Lok® ORFS female swivel end / O-Lok® ORFS tube ends
SAE 52M0433 ISO 8434-3 SWBT

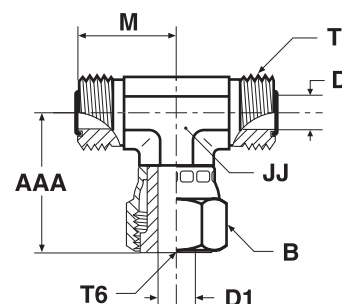

Tube O.D.		Thread UN/UNF-2A T	Thread UN/UNF-2B T6	AAA mm	B mm	D mm	D1 mm	JJ* mm	M mm	Weight (steel) g/1 piece	O-Lok® Steel	O-Lok® Stainless Steel	PN (bar)	
mm	in.												S	SS
6	1/4	9/16-18	9/16-18	26	17	4.5	4.0	14	22	66	4S6MLOS	4S6MLOSS	500	420
8, 10	5/16, 3/8	11/16-16	11/16-16	29	22	6.5	6.5	19	25	125	6S6MLOS	6S6MLOSS	630	420
12	1/2	13/16-16	13/16-16	38	24	9.5	9.0	19	28	150	8S6MLOS	8S6MLOSS	630	420
14, 15, 16	5/8	1-14	1-14	41	30	12.5	11.5	27	33	233	10S6MLOS	10S6MLOSS	420	420
18, 20	3/4	1 3/16-12	1 3/16-12	47	35	15.5	14.0	30	38	383	12 S6LO-S	12S6MLOSS	420	420
22, 25	1	1 7/16-12	1 7/16-12	54	41	20.5	20.0	36	42	518	16 S6LO-S	16S6MLOSS	420	420
28, 30, 32	1 1/4	1 11/16-12	1 11/16-12	58	48	26.0	26.0	41	45	775	20 S6LO-S	20S6MLOSS	350	280
35, 38	1 1/2	2-12	2-12	61	57	32.0	32.0	48	49	933	24 S6LO-S	24S6MLOSS	280	280

Product delivered with NBR TRAP seal. Replacement of TRAP seal is with a standard NBR O-ring – see page J73-J74.

Part numbers shown are part of our current manufacturing programme.

Imperial and metric parts may vary in hexagon dimensions.

$$\frac{\text{PN (bar)}}{10} = \text{PN (MPa)}$$

Do not create drawings from these dimensions, they are subject to change and ISO manufacturing allowances.

*JJ may vary in stainless steel

J

R6MLO Swivel nut run tee

O-Lok® ORFS female swivel end / O-Lok® ORFS tube ends
 SAE 52M0432 ISO 8434-3 SWRT

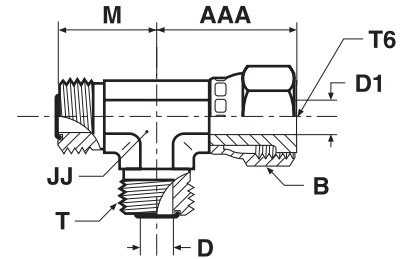

Tube O.D.		Thread UN/UNF-2A T	Thread UN/UNF-2B T6	AAA mm	B mm	D mm	D1 mm	JJ* mm	M mm	Weight (steel) g/1 piece	O-Lok® Steel	O-Lok® Stainless Steel	PN (bar)	
mm	in.												S	SS
6	1/4	9/16-18	9/16-18	26	17	4.5	4.0	14	22	66	4R6MLOS	4R6MLOSS	500	420
8, 10	5/16, 3/8	11/16-16	11/16-16	29	22	6.5	6.5	19	25	125	6R6MLOS	6R6MLOSS	630	420
12	1/2	13/16-16	13/16-16	38	24	9.5	9.0	19	28	150	8R6MLOS	8R6MLOSS	630	420
14, 15, 16	5/8	1-14	1-14	41	30	12.5	11.5	27	33	233	10R6MLOS	10R6MLOSS	420	420
18, 20	3/4	1 3/16-12	1 3/16-12	47	35	15.5	14.0	30	38	383	12 R6LO-S	12R6MLOSS	420	420
22, 25	1	1 7/16-12	1 7/16-12	54	41	20.5	20.0	36	42	518	16 R6LO-S	16R6MLOSS	420	420
28, 30, 32	1 1/4	1 11/16-12	1 11/16-12	58	48	26.0	26.0	41	45	775	20 R6LO-S	20R6MLOSS	350	280
35, 38	1 1/2	2-12	2-12	61	57	32.0	32.0	48	49	933	24 R6LO-S	24R6MLOSS	280	280

Product delivered with NBR TRAP seal. Replacement of TRAP seal is with a standard NBR O-ring – see page J73-J74.

Part numbers shown are part of our current manufacturing programme.

Imperial and metric parts may vary in hexagon dimensions.

$$\frac{PN \text{ (bar)}}{10} = PN \text{ (MPa)}$$

Do not create drawings from these dimensions, they are subject to change and ISO manufacturing allowances.

*JJ may vary in stainless steel

TRMLO Tube end reducer

O-Lok® ORFS tube end / O-Lok® ORFS swivel female end
SAE 520123 /A

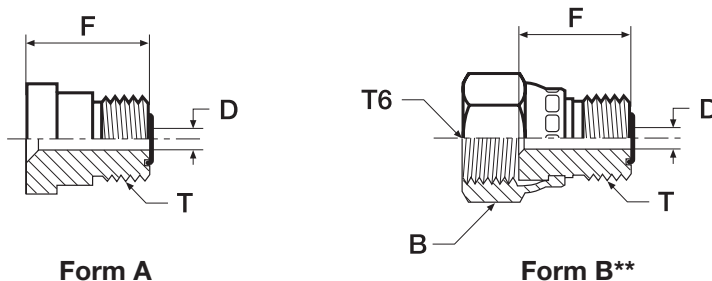

* For Form A, a BL- or BML-nut is required (to be ordered separately)

Tube O.D.		Thread UN/UNF-2A T	Thread UN/UNF-2B T6	B	D	F	Weight (steel)	Form	O-Lok® Steel	O-Lok® Stainless Steel	PN (bar)	
mm	in.			mm	mm	mm	g/1 piece				S	SS
10	3/8	9/16-18	11/16-16	22	4.5	20	21	B	6-4TRMLONS	6-4TRMLONSS	630	420
12	1/2	9/16-18	—	—	4.5	22	30	A	8-4 TRLO-S	8-4TRMLOSS	630	420
12	1/2	11/16-16	13/16-16	24	6.5	22	33	B	8-6TRMLONS	8-6TRMLONSS	630	420
16	5/8	9/16-18	—	—	4.5	23	37	A	10-4 TRLO-S	10-4TRMLOSS	420	420
16	5/8	11/16-16	—	—	6.5	24	48	A	10-6 TRLO-S	10-6TRMLOSS	420	420
16	5/8	13/16-16	—	—	9.5	26	50	A	10-8 TRLO-S	10-8TRMLOSS	420	420
20	3/4	9/16-18	—	—	4.5	25	63	A	12-4 TRLO-S	12-4TRMLOSS	420	420
20	3/4	11/16-16	—	—	6.5	26	66	A	12-6 TRLO-S	12-6TRMLOSS	420	420
20	3/4	13/16-16	—	—	9.5	28	71	A	12-8 TRLO-S	12-8TRMLOSS	420	420
20	3/4	1-14	1 3/16-12	36	12.5	30	85	B	12-10TRMLONS	12-10TRMLONSS	420	420
25	1	13/16-16	—	—	9.5	29	103	A	16-8 TRLO-S	16-8TRMLOSS	420	420
25	1	1-14	—	—	12.5	32	118	A	16-10 TRLO-S	16-10TRMLOSS	420	420
25	1	1 3/16-12	1 7/16-12	41	15.5	33	133	B	16-12 TRLO-S	16-12TRMLONSS	420	420
32	1 1/4	1-14	—	—	12.5	32	163	A	20-10TRLOS	20-10TRMOLSS	420	420
32	1 1/4	1 3/16-12	—	—	15.5	34	169	A	20-12 TRLO-S	20-12TRMLOSS	420	280
32	1 1/4	1 7/16-12	1 11/16-12	48	20.5	38	183	B	20-16 TRLO-S	20-16TRMLONSS	350	280
38	1 1/2	1 7/16-12	—	—	20.5	34	205	A	24-16 TRLO-S	24-16TRMLOSS	350	280
38	1 1/2	1 11/16-12	—	—	26.0	34	209	A	24-20 TRLO-S	24-20TRMLOSS	350	280

Product delivered with NBR TRAP seal. Replacement of TRAP seal is with a standard NBR O-ring – see page J73-J74.

Part numbers shown are part of our current manufacturing programme.

Imperial and metric parts may vary in hexagon dimensions.

$$\frac{\text{PN (bar)}}{10} = \text{PN (MPa)}$$

Do not create drawings from these dimensions, they are subject to change and ISO manufacturing allowances.

**These size come assembled with a crimp style nut (Form B).

J

LOHL6 Tube end expander

O-Lok® ORFS tube end / O-Lok® ORFS female swivel end

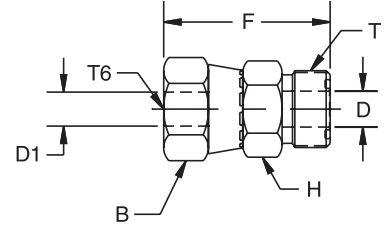

Tube O.D.		Thread UN/UNF-2A T	Thread UN/UNF-2B T6	B mm	D mm	D1 mm	H mm	F mm	Weight (steel) g/1 piece	O-Lok® Steel	PN (bar)
mm	in.										
8, 10	5/16, 3/8	11/16-16	9/16-18	18	4.0	4.0	19	35	33	6-4 LOHL6-S	630
12	1/2	13/16-16	11/16-16	21	9.5	6.5	22	41	52	8-6 LOHL6-S	630
14, 15, 16	5/8	1-14	13/16-16	24	12.5	9.0	27	46	92	10-8 LOHL6-S	420
18, 20	3/4	1 3/16-12	1-14	29	15.5	11.5	32	51	146	12-10 LOHL6-S	420
22, 25	1	1 7/16-12	1 3/16-12	35	20.5	14.0	38	55	205	16-12 LOHL6-S	420
28, 30, 32	1 1/4	1 11/16-12	1 7/16-12	42	26.0	20.0	45	58	260	20-16 LOHL6-S	350
35, 38	1 1/2	2-12	1 11/16-12	48	32.0	26.0	54	60	315	24-20 LOHL6-S	280

Product delivered with NBR TRAP seal. Replacement of TRAP seal is with a standard NBR O-ring – see page J73-J74.

Part numbers shown are part of our current manufacturing programme.

Imperial and metric parts may vary in hexagon dimensions.

$$\frac{\text{PN (bar)}}{10} = \text{PN (MPa)}$$

Do not create drawings from these dimensions, they are subject to change and ISO manufacturing allowances.

HL6 Swivel nut union

O-Lok® ORFS female swivel ends

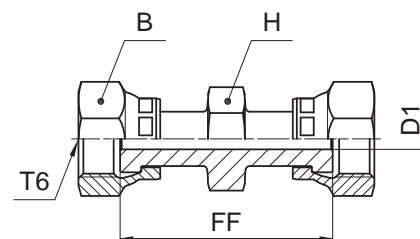

mm	Tube O.D.		Thread UN/UNF-2B T6	B mm	D1 mm	FF mm	H mm	Weight (steel) g/1 piece	O-Lok® Steel	PN (bar)
	mm	in.								
6		1/4	9/16-18	18	4.0	40	16	53	4 HL6-S	500
8, 10		5/16, 3/8	11/16-16	21	6.5	45	19	66	6 HL6-S	630
12		1/2	13/16-16	24	9.0	54	22	110	8 HL6-S	630
14, 15, 16		5/8	1-14	29	11.5	62	27	173	10 HL6-S	420
18, 20		3/4	1 3/16-12	35	14.0	70	32	275	12 HL6-S	420
22, 25		1	1 7/16-12	41	20.0	75	37	499	16 HL6-S	420

Part numbers shown are part of our current manufacturing programme.

Imperial and metric parts may vary in hexagon dimensions.

$$\frac{\text{PN (bar)}}{10} = \text{PN (MPa)}$$

Do not create drawings from these dimensions, they are subject to change and ISO manufacturing allowances.

J

F87OMLO Male stud connector

O-Lok® ORFS tube end / Male metric thread – O-ring (ISO 6149-2)
 SAE 52M0187 ISO 8434-3 SDS

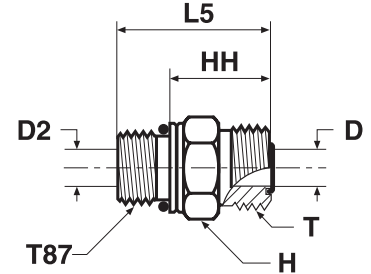

Tube O.D.		Thread metric T87	Thread UN/UNF-2A T	D mm	D2 mm	H mm	HH mm	L5 mm	Weight (steel) g/1 piece	O-Lok® Steel	O-Lok® Stainless Steel	PN (bar)	
mm	in.											S	SS
6	1/4	M 10×1.0	9/16-18	4.5	3.0	17	18	27	20	4M10F87OMLOS	4M10F87OMLOSS	630	630
6	1/4	M 12×1.5	9/16-18	4.5	4.0	17	18	29	24	4M12F87OMLOS	4M12F87OMLOSS	630	630
6	1/4	M 14×1.5	9/16-18	4.5	4.5	19	19	30	30	4M14F87OMLOS	4M14F87OMLOSS	630	630
6	1/4	M 16×1.5	9/16-18	4.5	7.0	22	20	33	35	4M16F87OMLOS	4M16F87OMLOSS	630	630
8, 10	5/16, 3/8	M 12×1.5	11/16-16	6.5	4.0	19	21	32	40	6M12F87OMLOS	6M12F87OMLOSS	630	630
8, 10	5/16, 3/8	M 14×1.5	11/16-16	6.5	6.0	19	21	32	43	6M14F87OMLOS	6M14F87OMLOSS	630	630
8, 10	5/16, 3/8	M 16×1.5	11/16-16	6.5	6.5	22	21	34	43	6M16F87OMLOS	6M16F87OMLOSS	630	630
8, 10	5/16, 3/8	M 18×1.5	11/16-16	6.5	9.0	24	22	36	45	6M18F87OMLOS	6M18F87OMLOSS	630	630
8, 10	5/16, 3/8	M 22×1.5	11/16-16	6.5	6.5	27	23	38	52	6M22F87OMLOS	6M22F87OMLOSS	420	420
12	1/2	M 14×1.5	13/16-16	9.5	6.0	22	24	35	40	8M14F87OMLOS	8M14F87OMLOSS	630	630
12	1/2	M 16×1.5	13/16-16	9.5	7.0	22	24	37	58	8M16F87OMLOS	8M16F87OMLOSS	630	630
12	1/2	M 18×1.5	13/16-16	9.5	9.0	24	24	38	55	8M18F87OMLOS	8M18F87OMLOSS	630	630
12	1/2	M 22×1.5	13/16-16	9.5	9.5	27	24	39	60	8M22F87OMLOS	8M22F87OMLOSS	420	420
12	1/2	M 27×2.0	13/16-16	9.5	9.5	32	26	44	70	8M27F87OMLOS	8M27F87OMLOSS	420	420
14, 15, 16	5/8	M 18×1.5	1-14	12.5	9.0	27	27	41	120	10M18F87OMLOS	10M18F87OMLOSS	420	420
14, 15, 16	5/8	M 22×1.5	1-14	12.5	12.0	27	27	42	127	10M22F87OMLOS	10M22F87OMLOSS	420	420
14, 15, 16	5/8	M 27×2.0	1-14	12.5	13.0	32	29	47	177	10M27F87OMLOS	10M27F87OMLOSS	420	420
18, 20	3/4	M 22×1.5	1 3/16-12	15.5	12.0	32	30	45	170	12M22F87OMLOS	12M22F87OMLOSS	420	420
18, 20	3/4	M 27×2.0	1 3/16-12	15.5	15.0	32	30	49	187	12M27F87OMLOS	12M27F87OMLOSS	420	420
18, 20	3/4	M 33×2.0	1 3/16-12	15.5	20.0	41	33	52	200	12M33F87OMLOS	12M33F87OMLOSS	420	420
22, 25	1	M 27×2.0	1 7/16-12	20.5	15.0	41	34	52	230	16M27F87OMLOS	16M27F87OMLOSS	420	420
22, 25	1	M 33×2.0	1 7/16-12	20.5	20.0	41	34	52	270	16M33F87OMLOS	16M33F87OMLOSS	420	280
28, 30, 32	1 1/4	M 33×2.0	1 11/16-12	26.0	20.0	46	36	54	370	20M33F87OMLOS	20M33F87OMLOSS	420	280
28, 30, 32	1 1/4	M 42×2.0	1 11/16-12	26.0	26.0	50	36	55	390	20M42F87OMLOS	20M42F87OMLOSS	420	280
35, 38	1 1/2	M 42×2.0	2-12	32.0	26.0	55	36	55	400	24M42F87OMLOS	24M42F87OMLOSS	350	280
35, 38	1 1/2	M 48×2.0	2-12	32.0	32.0	55	36	57	412	24M48F87OMLOS	24M48F87OMLOSS	350	280

Product delivered with NBR TRAP seal. Replacement of TRAP seal is with a standard NBR O-ring – see page J73-J74.

Part numbers shown are part of our current manufacturing programme.

Imperial and metric parts may vary in hexagon dimensions.

$$\frac{\text{PN (bar)}}{10} = \text{PN (MPa)}$$

Do not create drawings from these dimensions, they are subject to change and ISO manufacturing allowances.

F5OMLO Male stud connector

O-Lok® ORFS tube end / Male UN/UNF thread – O-ring (ISO 11926)
SAE 520120

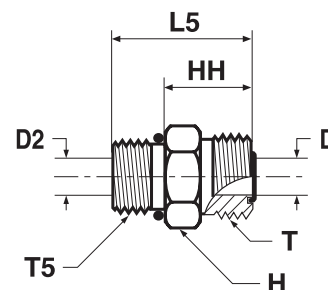

Tube O.D.		Thread UN/UNF-2A T5	Thread UN/UNF-2A T	D	D2	H	HH	L5	Weight (steel)	O-Lok® Steel	O-Lok® Stainless Steel	PN (bar)	
mm	in.			mm	mm	mm	mm	mm	g/1 piece			S	SS
6	1/4	7/16-20	9/16-18	4.5	4.5	17	18	29	21	4F5OMLOS	4F5OMLOSS	630	630
6	1/4	1/2-20	9/16-18	4.5	4.5	16	19	30	30	4-5 F5OLO-S	4-5F5OMLOSS	630	630
6	1/4	9/16-18	9/16-18	4.5	7.5	19	19	31	36	4-6F5OMLOS	4-6F5OMLOSS	630	630
6	1/4	3/4-16	9/16-18	4.5	10.0	22	20	34	67	4-8 F5OLO-S	4-8F5OMLOSS	630	630
8, 10	5/16, 3/8	9/16-18	11/16-16	6.5	6.5	19	20	32	45	6F5OMLOS	6F5OMLOSS	630	630
8, 10	5/16, 3/8	7/16-20	11/16-16	6.5	4.5	19	23	34	47	6-4F5OMLOS	6-4F5OMLOSS	630	630
8, 10	5/16, 3/8	1/2-20	11/16-16	6.5	6.0	19	20	31	50	6-5 F5OLO-S	6-5F5OMLOSS	630	630
8, 10	5/16, 3/8	3/4-16	11/16-16	6.5	10.0	22	21	35	51	6-8F5OMLOS	6-8F5OMLOSS	630	630
8, 10	5/16, 3/8	7/8-14	11/16-16	6.5	6.5	27	23	39	89	6-10F5OMLOS	6-10F5OMLOSS	420	420
12	1/2	3/4-16	13/16-16	9.5	9.5	22	23	37	56	8F5OMLOS	8F5OMLOSS	630	630
12	1/2	7/16-20	13/16-16	9.5	4.5	22	25	36	63	8-4 F5OLO-S	8-4F5OMLOSS	630	630
12	1/2	9/16-18	13/16-16	9.5	7.5	22	26	38	69	8-6F5OMLOS	8-6F5OMLOSS	630	630
12	1/2	7/8-14	13/16-16	9.5	9.5	27	24	40	105	8-10F5OMLOS	8-10F5OMLOSS	420	420
12	1/2	1 1/16-12	13/16-16	9.5	9.5	32	26	44	169	8-12F5OMLOS	8-12F5OMLOSS	420	420
12	1/2	1 5/16-12	13/16-16	9.5	21.5	41	27	46	227	8-16F5OMLOS	8-16F5OMLOSS	420	420
14, 15, 16	5/8	7/8-14	1-14	12.5	12.5	27	27	43	137	10F5OMLOS	10F5OMLOSS	420	420
14, 15, 16	5/8	9/16-18	1-14	12.5	7.5	27	30	42	110	10-6 F5OLO-S	10-6F5OMLOSS	420	420
14, 15, 16	5/8	3/4-16	1-14	12.5	10.0	27	31	45	120	10-8F5OMLOS	10-8F5OMLOSS	420	420
14, 15, 16	5/8	1 1/16-12	1-14	12.5	12.5	32	29	47	170	10-12F5OMLOS	10-12F5OMLOSS	420	420
18, 20	3/4	1 1/16-12	1 3/16-12	15.5	15.5	32	30	49	189	12F5OMLOS	12F5OMLOSS	420	420
18, 20	3/4	3/4-16	1 3/16-12	15.5	10.0	32	35	49	167	12-8 F5OLO-S	12-8F5OMLOSS	420	420
18, 20	3/4	7/8-14	1 3/16-12	15.5	12.5	32	35	51	177	12-10F5OMLOS	12-10F5OMLOSS	420	420
18, 20	3/4	1 5/16-12	1 3/16-12	15.5	15.5	41	31	50	280	12-16F5OMLOS	12-16F5OMLOSS	420	420
18, 20	3/4	1 5/8-12	1 3/16-12	15.5	27.5	46	32	51	350	12-20F5OMLOS	12-20F5OMLOSS	420	420
22, 25	1	1 5/16-12	1 7/16-12	20.5	20.5	38	32	50	271	16 F5OLO-S	16F5OMLOSS	420	420
22, 25	1	1 1/16-12	1 7/16-12	20.5	15.5	38	36	54	275	16-12 F5OLO-S	16-12F5OMLOSS	420	420
22, 25	1	1 3/16-12	1 7/16-12	20.5	17.0	38	32	51	279	16-14F5OMLOS	16-14F5OMLOSS	420	420
22, 25	1	1 5/8-12	1 7/16-12	20.5	27.5	48	34	52	428	16-20 F5OLO-S	16-20F5OMLOSS	420	280
28, 30, 32	1 1/4	1 5/8-12	1 11/16-12	26.0	26.0	50	34	52	391	20F5OMLOS	20F5OMLOSS	420	280
28, 30, 32	1 1/4	1 5/16-12	1 11/16-12	26.0	21.5	48	39	58	401		20-16F5OMLOSS		280
28, 30, 32	1 1/4	1 5/16-12	1 11/16-12	26.0	21.5	46	39	58	430	20-16 F5OLO-S		420	
28, 30, 32	1 1/4	1 7/8-12	1 11/16-12	26.0	32.0	54	36	54	557	20-24 F5OLO-S	20-24F5OMLOSS	350	280
35, 38	1 1/2	1 7/8-12	2-12	32.0	32.0	54	36	54	412	24 F5OLO-S	24F5OMLOSS	350	280
35, 38	1 1/2	1 5/8-12	2-12	32.0	27.5	54	41	60	581	24-20 F5OLO-S	24-20F5OMLOSS	350	280

Product delivered with NBR TRAP seal. Replacement of TRAP seal is with a standard NBR O-ring – see page J73-J74.

Part numbers shown are part of our current manufacturing programme.

Imperial and metric parts may vary in hexagon dimensions.

$$\frac{\text{PN (bar)}}{10} = \text{PN (MPa)}$$

Do not create drawings from these dimensions, they are subject to change and ISO manufacturing allowances.

FF5OMLO Extended male stud connector

O-Lok® ORFS tube end / Male UN/UNF thread – O-ring (ISO 11926)
 SAE 521720 (Previously 520122)

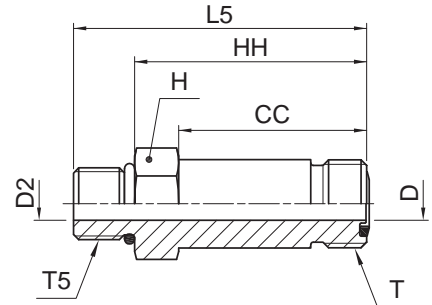

Tube O.D.		Thread UN/UNF-2A T5	Thread UN/UNF-2A T	CC mm	D mm	D2 mm	H mm	HH mm	L5 mm	Weight (steel) g/1 piece	O-Lok® Steel	O-Lok® Stainless Steel	PN (bar)	
mm	in.												S	SS
6	1/4	7/16-20	9/16-18	34	4.5	4.5	16	42	53	51	4 FF5OLO-S	4FF5OMLOSS	630	630
8, 10	5/16, 3/8	9/16-18	11/16-16	37	6.5	6.5	19	46	58	79	6 FF5OLO-S	6FF5OMLOSS	630	630
12	1/2	3/4-16	13/16-16	45	9.5	9.5	22	54	68	125	8 FF5OLO-S	8FF5OMLOSS	630	630
14, 15, 16	5/8	7/8-14	1-14	53	12.5	12.5	27	64	80	212	10 FF5OLO-S	10FF5OMLOSS	420	420
18, 20	3/4	1 1/16-12	1 3/16-12	64	15.5	15.5	32	77	96	309	12 FF5OLO-S	12FF5OMLOSS	420	420
22, 25	1	1 5/16-12	1 7/16-12	73	20.5	20.5	38	87	105	435	16 FF5OLO-S	16FF5OMLOSS	420	420
28, 30, 32	1 1/4	1 5/8-12	1 11/16-12	86	26.0	26.0	48	102	121	818	20 FF5OLO-S	20FF5OMLOSS	420	280
35, 38	1 1/2	1 7/8-12	2-12	97	32.0	32.0	54	115	134	1430	24 FF5OLO-S	24FF5OMLOSS	350	280

Product delivered with NBR TRAP seal. Replacement of TRAP seal is with a standard NBR O-ring – see page J73-J74.

Part numbers shown are part of our current manufacturing programme.

Imperial and metric parts may vary in hexagon dimensions.

$$\frac{PN \text{ (bar)}}{10} = PN \text{ (MPa)}$$

Do not create drawings from these dimensions, they are subject to change and ISO manufacturing allowances.

WF5OLO Bulkhead male connector

O-Lok® ORFS tube end / Male UN/UNF – O-ring (ISO 11926)

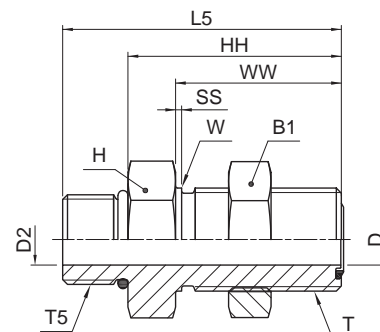

Tube O.D.		Thread UN/UNF-2A T	Thread UN/UNF-2A T5	B1	D	D2	H	HH	L5	SS	W	WW	Weight (steel)	O-Lok® Steel	PN (bar)
mm	in.			mm	mm	mm	mm	mm	mm	mm	mm	mm	g/1 piece		
6	1/4	9/16-18	7/16-20	21	4.5	4.5	21	43	54	2	14	32	75	4 WF5OLO-WLNL-S	630
8, 10	5/16, 3/8	11/16-16	9/16-18	25	6.5	6.5	25	47	59	2	18	34	112	6 WF5OLO-WLNL-S	630
12	1/2	13/16-16	3/4-16	29	9.5	9.5	29	52	66	2	21	37	147	8 WF5OLO-WLNL-S	630
14, 15, 16	5/8	1-14	7/8-14	33	12.5	12.5	33	52	68	2	25	41	295	10 WF5OLO-WLNL-S	420
18, 20	3/4	1 3/16-12	1 1/16-12	38	15.5	15.5	38	55	73	2	30	42	330	12 WF5OLO-WLNL-S	420

Product delivered with NBR TRAP seal. Replacement of TRAP seal is with a standard NBR O-ring – see page J73-J74.

Part numbers shown are part of our current manufacturing programme.

Imperial and metric parts may vary in hexagon dimensions.

For the version without the locknut remove “WLNL” (e.g. 12 WF5OLO)

$$\frac{\text{PN (bar)}}{10} = \text{PN (MPa)}$$

Do not create drawings from these dimensions, they are subject to change and ISO manufacturing allowances.

J

F42EDMLO Male stud connector

O-Lok® ORFS tube end / Male BSPP thread – ED seal (ISO 1179)

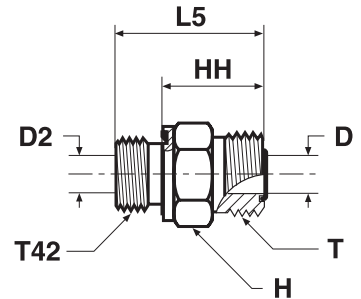

Tube O.D.		BSPP male thread T42	Thread UN/UNF-2A T	D mm	D2 mm	H mm	HH mm	L5 mm	Weight (steel) g/1 piece	O-Lok® Steel	O-Lok® Stainless Steel	PN (bar)	
mm	in.											S	SS
6	1/4	1/8-28	9/16-18	4.5	4.0	17	18	26	29	4F42EDMLOS	4F42EDMLOSS	630	630
6	1/4	1/4-19	9/16-18	4.5	4.5	19	19	31	42	4-4F42EDMLOS	4-4F42EDMLOSS	630	630
6	1/4	3/8-19	9/16-18	4.5	4.5	22	20	32	61	4-6F42EDMLOS	4-6F42EDMLOSS	630	630
6	1/4	1/2-14	9/16-18	4.5	4.5	27	22	36	119	4-8F42EDMLOS	4-8F42EDMLOSS	420	420
8, 10	5/16, 3/8	1/4-19	11/16-16	6.5	5.0	19	20	32	45	6F42EDMLOS	6F42EDMLOSS	630	630
8, 10	5/16, 3/8	1/8-28	11/16-16	6.5	4.0	19	23	31	44	6-2F42EDMLOS	6-2F42EDMLOSS	630	630
8, 10	5/16, 3/8	3/8-19	11/16-16	6.5	6.5	22	21	33	63	6-6F42EDMLOS	6-6F42EDMLOSS	630	630
8, 10	5/16, 3/8	1/2-14	11/16-16	6.5	6.5	27	23	37	122	6-8F42EDMLOS	6-8F42EDMLOSS	420	420
8, 10	5/16, 3/8	3/4-14	11/16-16	6.5	16.0	32	24	40	192	6-12F42EDMLOS	6-12F42EDMLOSS	420	420
12	1/2	3/8-19	13/16-16	9.5	8.0	22	23	35	196	8F42EDMLOS	8F42EDMLOSS	630	630
12	1/2	1/4-19	13/16-16	9.5	5.0	22	26	38	193	8-4F42EDMLOS	8-4F42EDMLOSS	630	630
12	1/2	1/2-14	13/16-16	9.5	9.5	27	25	39	198	8-8F42EDMLOS	8-8F42EDMLOSS	420	420
12	1/2	3/4-14	13/16-16	9.5	9.5	32	26	42	205	8-12F42EDMLOS	8-12F42EDMLOSS	420	420
14, 15, 16	5/8	1/2-14	1-14	12.5	12.5	27	27	41	332	10F42EDMLOS	10F42EDMLOSS	420	420
14, 15, 16	5/8	3/8-19	1-14	12.5	8.0	27	31	43	315	10-6F42EDMLOS	10-6F42EDMLOSS	420	420
14, 15, 16	5/8	3/4-14	1-14	12.5	12.5	32	29	45	348	10-12F42EDMLOS	10-12F42EDMLOSS	420	420
14, 15, 16	5/8	1-11	1-14	12.5	12.5	41	30	48	360	10-16F42EDMLOS	10-16F42EDMLOSS	420	420
18, 20	3/4	3/4-14	1 3/16-12	15.5	15.5	32	30	46	200	12F42EDMLOS	12F42EDMLOSS	420	420
18, 20	3/4	1/2-14	1 3/16-12	15.5	12.0	32	35	49	183	12-8F42EDMLOS	12-8F42EDMLOSS	420	420
18, 20	3/4	1-11	1 3/16-12	15.5	15.5	41	32	50	362	12-16F42EDMLOS	12-16F42EDMLOSS	420	420
18, 20	3/4	1 1/4-11	1 3/16-12	15.5	16.0	50	34	54	505	12-20F42EDMLOS	12-20F42EDMLOSS	420	420
22, 25	1	1-11	1 7/16-12	20.5	20.0	41	32	50	343	16F42EDMLOS	16F42EDMLOSS	420	420
22, 25	1	1/2-14	1 7/16-12	20.5	12.0	41	36	50	380	16-8F42EDMLOS	16-8F42EDMLOSS	420	420
22, 25	1	3/4-14	1 7/16-12	20.5	16.0	41	36	52	411	16-12F42EDMLOS	16-12F42EDMLOSS	420	420
22, 25	1	1 1/4-11	1 7/16-12	20.5	20.5	50	34	54	487	16-20F42EDMLOS	16-20F42EDMLOSS	420	420
22, 25	1	1 1/2-11	1 7/16-12	20.5	20.5	55	36	58	715	16-24F42EDMLOS	16-24F42EDMLOSS	350	280
28, 30, 32	1 1/4	1 1/4-11	1 11/16-12	25.0	25.0	50	34	54	454	20F42EDMLOS	20F42EDMLOSS	420	280
28, 30, 32	1 1/4	3/4-14	1 11/16-12	26.0	16.0	46	37	53	362	20-12F42EDMLOS	20-12F42EDMLOSS	420	280
28, 30, 32	1 1/4	1-11	1 11/16-12	26.0	20.0	46	39	57	412	20-16F42EDMLOS	20-16F42EDMLOSS	420	280
28, 30, 32	1 1/4	1 1/2-11	1 11/16-12	26.0	26.0	55	36	58	532	20-24F42EDMLOS	20-24F42EDMLOSS	350	280
35, 38	1 1/2	1 1/2-11	2-12	32.0	32.0	55	36	58	585	24F42EDMLOS	24F42EDMLOSS	350	280
35, 38	1 1/2	1-11	2-12	32.0	20.0	55	41	59	471	24-16F42EDMLOS	24-16F42EDMLOSS	350	280
35, 38	1 1/2	1 1/4-11	2-12	32.0	25.0	55	41	61	540	24-20F42EDMLOS	24-20F42EDMLOSS	350	280

Product delivered with NBR TRAP seal. Replacement of TRAP seal is with a standard NBR O-ring – see page J73-J74.

Part numbers shown are part of our current manufacturing programme.

Imperial and metric parts may vary in hexagon dimensions.

$$\frac{\text{PN (bar)}}{10} = \text{PN (MPa)}$$

Do not create drawings from these dimensions, they are subject to change and ISO manufacturing allowances.

FF42EDMLO Extended male stud connector

O-Lok® ORFS tube end / Male BSPP thread - ED seal (ISO 1179-2)

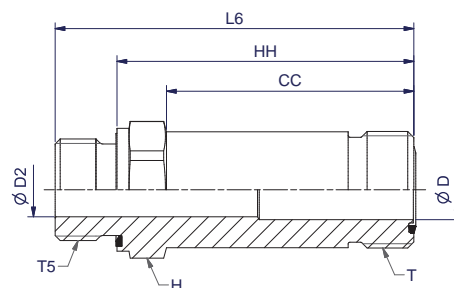

Tube O.D.		Thread UN/UNF-2A	Thread BSPP	CC mm	D mm	D2 mm	H mm	HH mm	L6 mm	Weight (steel) g/1 piece	O-Lok® Steel	O-Lok® Stainless Steel	PN (bar)	
mm	inch												S	SS
8, 10	5/16, 3/8	11/16-16	1/4-19	37	7	5	19	46	58	80	6FF42EDMLOS	6FF42EDMLOSS	630	630
12	1/2	13/16-16	3/8-14	44	10	8	22	54	66	130	8FF42EDMLOS	8FF42EDMLOSS	630	630
14, 15, 16	5/8	1-14	1/2-14	52	13	13	27	63	77	200	10FF42EDMLOS	10FF42EDMLOSS	420	420
18, 20	3/4	1 3/16-12	3/4-14	64	16	16	32	74	93	360	12FF42EDMLOS	12FF42EDMLOSS	420	420

Product delivered with NBR TRAP seal. Replacement of TRAP seal is with a standard NBR O-ring – see page J73-J74.

Order codes shown are part of our current manufacturing programme.

Imperial and metric parts may vary in hexagon dimensions.

$$\frac{\text{PN (bar)}}{10} = \text{PN (MPa)}$$

Do not create drawings from these dimensions, they are subject to change and ISO manufacturing allowances.

J

F82EDMLO Male stud connector

O-Lok® ORFS tube end / Male metric thread – ED seal (ISO 9974)

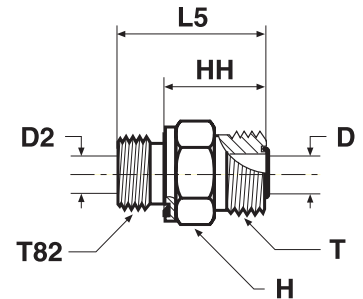

Tube O.D.		Thread metric T82	Thread UN/UNF-2A T	D mm	D2 mm	H mm	HH mm	L5 mm	Weight (steel) g/1 piece	O-Lok®		PN (bar)	
mm	in.									Steel	Stainless Steel	S	SS
6	1/4	M 10×1.0	9/16-18	4.5	4.0	17	18	26	20	4M10F82EDMLOS	4M10F82EDMLOSS	630	630
6	1/4	M 12×1.5	9/16-18	4.5	4.0	17	18	30	24	4M12F82EDMLOS	4M12F82EDMLOSS	630	630
6	1/4	M 14×1.5	9/16-18	4.5	4.5	19	19	31	29	4M14F82EDMLOS	4M14F82EDMLOSS	630	630
6	1/4	M 16×1.5	9/16-18	4.5	7.0	22	19	31	33	4M16F82EDMLOS	4M16F82EDMLOSS	630	630
8, 10	5/16, 3/8	M 12×1.5	11/16-16	6.5	4.0	19	23	35	35	6M12F82EDMLOS	6M12F82EDMLOSS	630	630
8, 10	5/16, 3/8	M 14×1.5	11/16-16	6.5	5.0	19	20	32	40	6M14F82EDMLOS	6M14F82EDMLOSS	630	630
8, 10	5/16, 3/8	M 16×1.5	11/16-16	6.5	6.5	22	20	32	43	6M16F82EDMLOS	6M16F82EDMLOSS	630	630
8, 10	5/16, 3/8	M 18×1.5	11/16-16	6.5	6.5	24	21	33	70	6M18F82EDMLOS	6M18F82EDMLOSS	630	630
8, 10	5/16, 3/8	M 22×1.5	11/16-16	6.5	12.0	27	23	37	83	6M22F82EDMLOS	6M22F82EDMLOSS	630	630
12	1/2	M 12×1.5	13/16-16	9.5	4.0	22	24	36	58	8M12F82EDMLOS	8M12F82EDMLOSS	630	630
12	1/2	M 14×1.5	13/16-16	9.5	5.0	22	23	35	57	8M14F82EDMLOS	8M14F82EDMLOSS	630	630
12	1/2	M 16×1.5	13/16-16	9.5	7.0	22	26	38	49	8M16F82EDMLOS	8M16F82EDMLOSS	630	630
12	1/2	M 18×1.5	13/16-16	9.5	8.0	24	23	35	55	8M18F82EDMLOS	8M18F82EDMLOSS	630	630
12	1/2	M 26×1.5	13/16-16	9.5	9.5	32	26	42	148	8M26F82EDMLOS	8M26F82EDMLOSS	420	420
14, 15, 16	5/8	M 16×1.5	1-14	12.5	7.0	27	30	42	70	10M16F82EDMLOS	10M16F82EDMLOSS	420	420
14, 15, 16	5/8	M 18×1.5	1-14	12.5	8.0	27	31	43	85	10M18F82EDMLOS	10M18F82EDMLOSS	420	420
14, 15, 16	5/8	M 22×1.5	1-14	12.5	12.0	27	27	41	127	10M22F82EDMLOS	10M22F82EDMLOSS	420	420
14, 15, 16	5/8	M 26×1.5	1-14	12.5	18.0	32	31	47	170	10M26F82EDMLOS	10M26F82EDMLOSS	420	420
18, 20	3/4	M 18×1.5	1 3/16-12	15.5	8.0	32	35	47	184	12M18F82EDMLOS	12M18F82EDMLOSS	420	420
18, 20	3/4	M 22×1.5	1 3/16-12	15.5	12.0	32	35	47	173	12M22F82EDMLOS	12M22F82EDMLOSS	420	420
18, 20	3/4	M 27×2.0	1 3/16-12	15.5	15.5	32	30	46	187	12M27F82EDMLOS	12M27F82EDMLOSS	420	420
22, 25	1	M 33×2.0	1 7/16-12	20.5	20.0	41	32	50	270	16M33F82EDMLOS	16M33F82EDMLOSS	420	420
28, 30, 32	1 1/4	M 42×2.0	1 11/16-12	26.0	25.0	50	34	54	390	20M42F82EDMLOS	20M42F82EDMLOSS	420	280
35, 38	1 1/2	M 48×2.0	2-12	32.0	32.0	55	36	58	412	24M48F82EDMLOS	24M48F82EDMLOSS	350	280

Product delivered with NBR TRAP seal. Replacement of TRAP seal is with a standard NBR O-ring – see page J73-J74.

Part numbers shown are part of our current manufacturing programme.

Imperial and metric parts may vary in hexagon dimensions.

$$\frac{\text{PN (bar)}}{10} = \text{PN (MPa)}$$

Do not create drawings from these dimensions, they are subject to change and ISO manufacturing allowances.

FLO Male stud connector

O-Lok® ORFS tube end / Male NPTF* thread (SAE J476)

*Stainless Steel = NPT to prevent galling

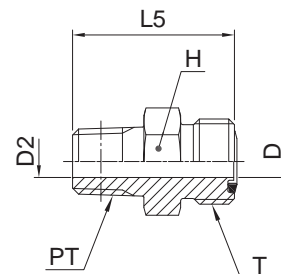

Tube O.D.		Thread NPTF PT	Thread UN/UNF-2A T	D mm	D2 mm	L5 mm	H mm	Weight (steel) g/1 piece	O-Lok® Steel	O-Lok® Stainless Steel	PN (bar)	
mm	in.										S	SS
6	1/4	1/8-27	9/16-18	4.5	4.5	27	16	26	4 FLO-S	4 FLO-SS	420	420
6	1/4	1/4-18	9/16-18	4.5	4.5	32	16	34	4-4 FLO-S	4-4 FLO-SS	420	420
6	1/4	3/8-18	9/16-18	4.5	4.5	34	19	47	4-6 FLO-S	4-6 FLO-SS	420	420
8, 10	5/16, 3/8	1/4-18	11/16-16	6.5	6.5	32	19	39	6 FLO-S	6 FLO-SS	420	420
8, 10	5/16, 3/8	3/8-18	11/16-16	6.5	6.5	34	19	52	6-6 FLO-S	6-6 FLO-SS	420	420
8, 10	5/16, 3/8	1/2-14	11/16-16	6.5	6.5	39	22	82	6-8 FLO-S	6-8 FLO-SS	420	420
12	1/2	3/8-18	13/16-16	9.5	9.5	38	22	83	8 FLO-S	8 FLO-SS	420	420
12	1/2	1/2-14	13/16-16	9.5	6.5	42	22	84	8-8 FLO-S	8-8 FLO-SS	420	420
12	1/2	3/4-14	13/16-16	9.5	9.5	43	29	166	8-12 FLO-S	8-12 FLO-SS	380	350
14, 15, 16	5/8	1/2-14	1-14	12.5	12.5	46	27	115	10 FLO-S	10 FLO-SS	420	420
14, 15, 16	5/8	3/4-14	1-14	12.5	12.5	46	29	138	10-12 FLO-S	10-12 FLO-SS	380	350
18, 20	3/4	3/4-14	1 3/16-12	15.5	15.5	49	32	179	12 FLO-S	12 FLO-SS	380	350
18, 20	3/4	1/2-14	1 3/16-12	15.5	13.5	49	32	165	12-8 FLO-S	12-8 FLO-SS	420	420
18, 20	3/4	1-11.5	1 3/16-12	15.5	15.5	54	35	225	12-16 FLO-S	12-16 FLO-SS	310	210
22, 25	1	1-11.5	1 7/16-12	20.5	20.5	56	38	271	16 FLO-S	16 FLO-SS	310	210
22, 25	1	3/4-14	1 7/16-12	20.5	18.3	51	38	238	16-12 FLO-S	16-12 FLO-SS	380	350
28, 30, 32	1 1/4	1 1/4-11.5	1 11/16-12	26.0	26.0	58	48	424	20 FLO-S	20 FLO-SS	210	210
35, 38	1 1/2	1 1/2-11.5	2-12	32.0	32.0	61	54	534	24 FLO-S	24 FLO-SS	200	175

Product delivered with NBR TRAP seal. Replacement of TRAP seal is with a standard NBR O-ring – see page J73-J74.

Part numbers shown are part of our current manufacturing programme.

Imperial and metric parts may vary in hexagon dimensions.

$$\frac{\text{PN (bar)}}{10} = \text{PN (MPa)}$$

Do not create drawings from these dimensions, they are subject to change and ISO manufacturing allowances.

F687OML Swivel male stud

O-Lok® ORFS Female swivel end / Male metric thread – O-ring (ISO 6149-2)

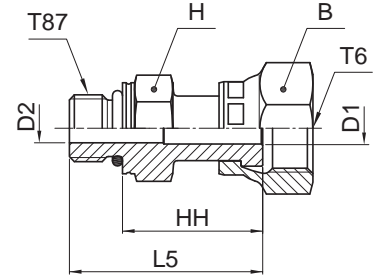

Tube O.D.		Thread metric T87	Thread UN/UNF-2B T6	B mm	H mm	D1 mm	D2 mm	L5 mm	HH mm	Weight (steel) g/1 piece	O-Lok®		PN (bar)	
mm	in.										Steel	Stainless Steel	S	SS
6	1/4	M 12×1.5	9/16-18	17	17	4.0	4.0	38	27	53	4M12F687OMLS	4M12F687OMLS	500	420
8, 10	3/8	M 14×1.5	11/16-16	22	19	6.5	6.0	40	29	72	6M14F687OMLS	6M14F687OMLS	630	420
8, 10	3/8	M 16×1.5	11/16-16	22	22	7.0	7.0	42	29	85	6M16F687OMLS	6M16F687OMLS	630	420
12	1/2	M 16×1.5	13/16-16	24	22	9.0	7.0	49	36	110	8M16F687OMLS	8M16F687OMLS	630	420
14, 15, 16	5/8	M 22×1.5	1-14	30	27	11.5	11.5	53	38	173	10M22F687OMLS	10M22F687OMLS	420	400
18, 20	3/4	M 22×1.5	1 3/16-12	36	30	14.0	12.0	57	42	230	12M22F687OMLS	12M22F687OMLS	420	400
18, 20	3/4	M 27×2.0	1 3/16-12	36	32	14.0	14.0	61	42	275	12M27F687OMLS	12M27F687OMLS	420	400
22, 25	1	M 33×2.0	1 7/16-12	41	41	20.0	20.0	68	49	462	16M33F687OMLS	16M33F687OMLS	420	400
28, 30, 32	1 1/4	M 42×2.0	1 11/16-12	50	50	26.0	26.0	71	52	622	20M42F687OMLS	20M42F687OMLS	350	280
35, 38	1 1/2	M 48×2.0	2-12	60	55	32.0	32.0	71	50	885	24M48F687OMLS	24M48F687OMLS	280	280

O-Lok® is delivered with NBR elastomeric seals as standard. For more details on other seal materials see page J73-J74.

Part numbers shown are part of our current manufacturing programme.

Imperial and metric parts may vary in hexagon dimensions.

$$\frac{\text{PN (bar)}}{10} = \text{PN (MPa)}$$

Do not create drawings from these dimensions, they are subject to change and ISO manufacturing allowances.

F65OL Swivel male stud

O-Lok® ORFS female swivel end / Male UN/UNF thread – O-ring (ISO 11926)
SAE 520181

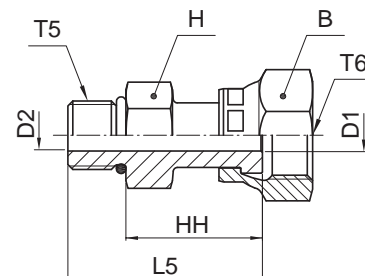

Tube O.D.		Thread UN/UNF-2A T5	Thread UN/UNF-2B T6	B	D1	D2	H	HH	L5	Weight (steel) g/1 piece	O-Lok® Steel	PN (bar)
mm	in.			mm	mm	mm	mm	mm	mm			
6	1/4	7/16-20	9/16-18	18	4.0	4.0	16	26	37	53	4 F65OL-S	500
8, 10	5/16, 3/8	9/16-18	11/16-16	21	6.5	6.5	19	28	40	66	6 F65OL-S	630
12	1/2	3/4-16	13/16-16	24	9.0	9.0	22	36	50	110	8 F65OL-S	630
14, 15, 16	5/8	7/8-14	1-14	29	11.5	12.5	27	38	54	173	10 F65OL-S	420
18, 20	3/4	1 1/16-12	1 3/16-12	35	14.0	15.5	32	41	59	275	12 F65OL-S	420
22, 25	1	1 5/16-12	1 7/16-12	41	20.0	20.0	38	49	68	462	16 F65OL-S	420
28, 30, 32	1 1/4	1 5/8-12	1 11/16-12	48	26.0	26.0	48	49	68	622	20 F65OL-S	350

O-Lok® is delivered with NBR elastomeric seals as standard. For more details on other seal materials see page J73-J74.

Part numbers shown are part of our current manufacturing programme.

Imperial and metric parts may vary in hexagon dimensions.

$$\frac{\text{PN (bar)}}{10} = \text{PN (MPa)}$$

Do not create drawings from these dimensions, they are subject to change and ISO manufacturing allowances.

J

F642EDML Swivel male stud

O-Lok® ORFS Swivel female end / Male BSPP thread – ED seal (ISO 1179)

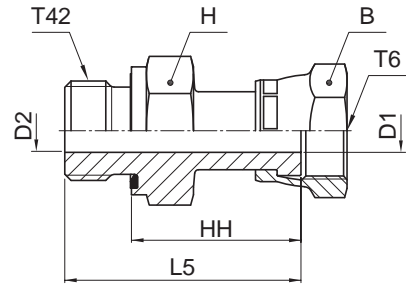

Tube O.D.		Thread BSPP T42	Thread UN/UNF-2B T6	B mm	H mm	D1 mm	D2 mm	L5 mm	HH mm	Weight (steel) g/1 piece	O-Lok®		PN (bar)	
mm	in.										Steel	Stainless Steel	S	SS
6	1/4	1/8-28	9/16-18	17	14	4.0	4.0	35	27	43	4F642EDMLS	4F642EDMLSS	500	420
6	1/4	1/4-19	9/16-18	17	19	4.0	4.0	39	27	59	4-4F642EDMLS	4-4F642EDMLSS	500	420
8, 10	5/16, 3/8	1/4-19	11/16-16	22	19	6.5	5.0	41	29	72	6F642EDMLS	6F642EDMLSS	630	420
8, 10	5/16, 3/8	3/8-19	11/16-16	22	22	6.5	6.5	41	29	86	6-6F642EDMLS	6-6F642EDMLSS	630	420
8, 10	5/16, 3/8	1/2-14	11/16-16	22	27	6.5	6.5	43	29	92	6-8F642EDMLS	6-8F642EDMLSS	420	420
12	1/2	3/8-19	13/16-16	24	22	9.0	8.0	48	36	104	8F642EDMLS	8F642EDMLSS	630	420
12	1/2	1/4-19	13/16-16	24	22	9.0	5.0	48	36	98	8-4F642EDMLS	8-4F642EDMLSS	630	420
12	1/2	1/2-14	13/16-16	24	27	9.0	9.0	50	36	142	8-8F642EDMLS	8-8F642EDMLSS	420	420
14, 15, 16	5/8	1/2-14	1-14	30	27	11.5	11.5	52	38	165	10F642EDMLS	10F642EDMLSS	420	420
14, 15, 16	5/8	3/4-14	1-14	30	32	11.5	11.5	54	38	185	10-12F642EDMLS	10-12F642EDMLSS	420	420
18, 20	3/4	3/4-14	1 3/16-12	36	32	14.0	14.0	58	42	266	12F642EDMLS	12F642EDMLSS	420	420
18, 20	3/4	1/2-14	1 3/16-12	36	30	14.0	12.0	56	42	220	12-8F642EDMLS	12-8F642EDMLSS	420	420
22, 25	1	1-11	1 7/16-12	41	41	20.0	20.0	67	49	414	16F642EDMLS	16F642EDMLSS	420	420
28, 30, 32	1 1/4	1-11	1 11/16-12	50	46	26.0	20.0	67	49	655	20-16F642EDMLS	20-16F642EDMLSS	350	280
28, 30, 32	1 1/4	1 1/4-11	1 11/16-12	50	50	26.0	25.0	69	49	623	20F642EDMLS	20F642EDMLSS	350	280
35, 38	1 1/2	1 1/2-11	2-12	60	55	32.0	32.0	72	50	885	24F642EDMLS	24F642EDMLSS	280	280

O-Lok® is delivered with NBR elastomeric seals as standard. For more details on other seal materials see page J73-J74.

Part numbers shown are part of our current manufacturing programme.

Imperial and metric parts may vary in hexagon dimensions.

$$\frac{\text{PN (bar)}}{10} = \text{PN (MPa)}$$

Do not create drawings from these dimensions, they are subject to change and ISO manufacturing allowances.

F682EDML Swivel male stud

O-Lok® ORFS Swivel female end / Male metric thread – ED seal (ISO 9974)

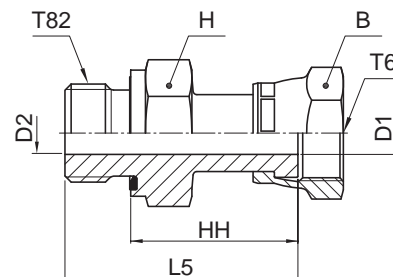

Tube O.D.		Thread metric T82	Thread UN/UNF-2B T6	B mm	H mm	D1 mm	D2 mm	L5 mm	HH mm	Weight (steel) g/1 piece	O-Lok® Steel	O-Lok® Stainless Steel	PN (bar)	
mm	in.												S	SS
6	1/4	M 12×1.5	9/16-18	17	17	4.0	4.0	39	27	56	4M12F682EDMLS	4M12F682EDMLSS	500	420
8, 10	5/16, 3/8	M 12×1.5	11/16-16	22	19	6.5	4.0	41	29	70	6M12F682EDMLS	6M12F682EDMLSS	500	420
8, 10	5/16, 3/8	M 14×1.5	11/16-16	22	19	6.5	5.0	41	29	73	6M14F682EDMLS	6M14F682EDMLSS	630	420
8, 10	5/16, 3/8	M 16×1.5	11/16-16	22	22	6.5	6.5	41	29	85	6M16F682EDMLS	6M16F682EDMLSS	630	420
12	1/2	M 16×1.5	13/16-16	24	22	9.0	7.0	48	36	109	8M16F682EDMLS	8M16F682EDMLSS	630	420
14, 15, 16	5/8	M 22×1.5	1-14	30	27	11.5	11.5	53	39	165	10M22F682EDMLS	10M22F682EDMLSS	420	420
18, 20	3/4	M 27×2.0	1 3/16-12	36	32	14.0	14.0	58	42	282	12M27F682EDMLS	12M27F682EDMLSS	420	420
22, 25	1	M 33×2.0	1 7/16-12	41	41	20.0	20.0	68	50	467	16M33F682EDMLS	16M33F682EDMLSS	420	420
28, 30, 32	1 1/4	M 42×2.0	1 11/16-12	50	50	26.0	26.0	70	50	635	20M42F682EDMLS	20M42F682EDMLSS	350	280
35, 38	1 1/2	M 48×2.0	2-12	60	55	32.0	32.0	72	50	885	24M48F682EDMLS	24M48F682EDMLSS	280	280

O-Lok® is delivered with NBR elastomeric seals as standard. For more details on other seal materials see page J73-J74.

Part numbers shown are part of our current manufacturing programme.

Imperial and metric parts may vary in hexagon dimensions.

$$\frac{\text{PN (bar)}}{10} = \text{PN (MPa)}$$

Do not create drawings from these dimensions, they are subject to change and ISO manufacturing allowances.

C87OMLO Male stud elbow

O-Lok® ORFS tube end / Male metric thread – O-ring (ISO 6149-2)
 SAE 52M0287 ISO 8434-3 SDE

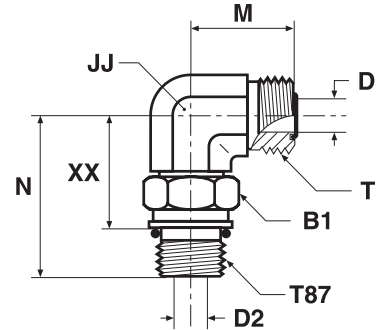

Tube O.D.		Thread metric T87	Thread UN/UNF-2B T	B1 mm	D mm	D2 mm	JJ* mm	M mm	N mm	XX mm	Weight (steel) g/1 piece	O-Lok®		PN (bar)	
mm	in.											Steel	Stainless Steel	S	SS
6	1/4	M 10×1.0	9/16-18	14	4.5	3	14	22	31	21	50	4M10C87OMLOS	4M10C87OMLOSS	420	420
6	1/4	M 12×1.5	9/16-18	17	4.5	4	14	22	33	21	52	4M12C87OMLOS	4M12C87OMLOSS	420	420
6	1/4	M 14×1.5	9/16-18	19	4.5	6	14	24	36	24	55	4M14C87OMLOS	4M14C87OMLOSS	420	420
8, 10	5/16, 3/8	M 12×1.5	11/16-16	17	6.5	4	19	25	36	24	60	6M12C87OMLOS	6M12C87OMLOSS	420	420
8, 10	5/16, 3/8	M 14×1.5	11/16-16	19	6.5	6	19	25	36	24	60	6M14C87OMLOS	6M14C87OMLOSS	420	420
8, 10	5/16, 3/8	M 16×1.5	11/16-16	22	6.5	7	19	25	38	24	65	6M16C87OMLOS	6M16C87OMLOSS	420	420
8, 10	5/16, 3/8	M 18×1.5	11/16-16	24	6.5	9	19	27	41	26	130	6M18C87OMLOS	6M18C87OMLOSS	420	420
12	1/2	M 14×1.5	13/16-16	19	9.5	6	19	28	36	24	150	8M14C87OMLOS	8M14C87OMLOSS	420	420
12	1/2	M 16×1.5	13/16-16	22	9.5	7	19	28	38	25	92	8M16C87OMLOS	8M16C87OMLOSS	420	420
12	1/2	M 18×1.5	13/16-16	24	9.5	9	19	28	41	26	161	8M18C87OMLOS	8M18C87OMLOSS	420	420
12	1/2	M 22×1.5	13/16-16	27	9.5	12	27	31	49	33	200	8M22C87OMLOS	8M22C87OMLOSS	420	420
14, 15, 16	5/8	M 18×1.5	1-14	24	12.5	9	27	33	48	33	190	10M18C87OMLOS	10M18C87OMLOSS	420	420
14, 15, 16	5/8	M 22×1.5	1-14	27	12.5	12	27	33	49	33	214	10M22C87OMLOS	10M22C87OMLOSS	420	420
18, 20	3/4	M 22×1.5	1 3/16-12	27	15.5	12	30	37	50	34	390	12M22C87OMLOS	12M22C87OMLOSS	420	420
18, 20	3/4	M 27×2.0	1 3/16-12	32	15.5	15	30	37	56	37	440	12M27C87OMLOS	12M27C87OMLOSS	420	420
22, 25	1	M 33×2.0	1 7/16-12	41	20.5	20	36	42	59	41	501	16M33C87OMLOS	16M33C87OMLOSS	420	420
28, 30, 32	1 1/4	M 33×2.0	1 11/16-12	41	26.0	20	41	45	62	43	530	20M33C87OMLOS	20M33C87OMLOSS	350	280
28, 30, 32	1 1/4	M 42×2.0	1 11/16-12	50	26.0	26	41	45	63	44	561	20M42C87OMLOS	20M42C87OMLOSS	280	280
35, 38	1 1/2	M 48×2.0	2-12	55	32.0	32	50	49	72	50	684	24M48C87OMLOS	24M48C87OMLOSS	280	280

Product delivered with NBR TRAP seal. Replacement of TRAP seal is with a standard NBR O-ring – see page J73-J74.

Part numbers shown are part of our current manufacturing programme.

Imperial and metric parts may vary in hexagon dimensions.

$$\frac{PN \text{ (bar)}}{10} = PN \text{ (MPa)}$$

Do not create drawings from these dimensions, they are subject to change and ISO manufacturing allowances.

*JJ may vary in stainless steel

C50MLO Male stud elbow

O-Lok® ORFS tube end / Male UN/UNF thread – O-ring (ISO 11926)
SAE 520220

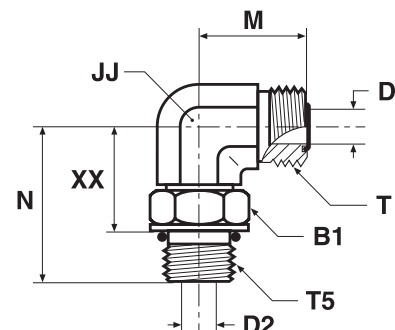

Tube O.D.		Thread UN/UNF-2A T5	Thread UN/UNF-2A T	B1 mm	D mm	D2 mm	JJ* mm	M mm	N mm	XX mm	Weight (steel) g/1 piece	O-Lok® Steel	O-Lok® Stainless Steel	PN (bar)	
mm	in.													S	SS
6	1/4	7/16-20	9/16-18	17	4.5	4.5	14	22	33	21	53	4C50MLOS	4C50MLOSS	420	420
6	1/4	9/16-18	9/16-18	19	4.5	7.5	19	24	37	24	66	4-6C50MLOS	4-6C50MLOSS	420	420
8, 10	3/8	9/16-18	11/16-16	19	6.5	7.5	19	25	37	24	68	6C50MLOS	6C50MLOSS	420	420
8, 10	3/8	7/16-20	11/16-16	16	6.5	4.5	19	25	35	24	57	6-4 C50LO-S	6-4C50MLOSS	420	420
8, 10	3/8	1/2-20	11/16-16	18	6.5	6.0	19	25	35	23	94	6-5 C50LO-S	6-5C50MLOSS	420	420
8, 10	3/8	3/4-16	11/16-16	24	6.5	10.0	19	26	41	26	105	6-8C50MLOS	6-8C50MLOSS	420	420
8, 10	3/8	7/8-14	11/16-16	27	6.5	12.5	22	29	50	33	196	6-10 C50LO-S	6-10C50MLOSS	420	420
8, 10	3/8	1 1/16-12	11/16-16	35	6.5	15.5	27	33	55	36	250	6-12 C50LO-S	6-12C50MLOSS	420	420
12	1/2	3/4-16	13/16-16	24	9.5	10.0	19	28	41	26	164	8C50MLOS	8C50MLOSS	420	420
12	1/2	1/2-20	13/16-16	18	9.5	6.0	19	28	35	23	101	8-5 C50LO-S	8-5C50MLOSS	420	420
12	1/2	9/16-18	13/16-16	19	9.5	7.5	19	28	37	24	81	8-6 C50LO-S	8-6C50MLOSS	420	420
12	1/2	7/8-14	13/16-16	27	9.5	12.5	27	31	50	33	187	8-10C50MLOS	8-10C50MLOSS	420	420
12	1/2	1 1/16-12	13/16-16	36	9.5	15.5	30	34	55	36	201	8-12C50MLOS	8-12C50MLOSS	420	420
14, 15, 16	5/8	7/8-14	1-14	27	12.5	12.5	27	33	50	33	214	10C50MLOS	10C50MLOSS	420	420
14, 15, 16	5/8	3/4-16	1-14	24	12.5	10.0	27	33	46	32	175	10-8 C50LO-S	10-8C50MLOSS	420	420
14, 15, 16	5/8	1 1/16-12	1-14	35	12.5	15.5	30	36	55	36	248	10-12 C50LO-S	10-12C50MLOSS	420	420
18, 20	3/4	1 1/16-12	1 3/16-12	36	15.5	15.5	30	37	55	36	442	12C50MLOS	12C50MLOSS	420	420
18, 20	3/4	3/4-16	1 3/16-12	24	15.5	10.0	30	37	47	32	325	12-8 C50LO-S	12-8C50MLOSS	420	420
18, 20	3/4	7/8-14	1 3/16-12	27	15.5	12.5	30	37	51	34	296	12-10C50MLOS	12-10C50MLOSS	420	420
18, 20	3/4	1 5/16-12	1 3/16-12	41	15.5	21.5	36	41	60	41	346	12-16 C50LO-S	12-16C50MLOSS	380	380
25	1	1 5/16-12	1 7/16-12	41	20.5	21.5	36	42	60	41	502	16 C50LO-S	16C50MLOSS	380	380
25	1	1 1/16-12	1 7/16-12	35	20.5	15.5	36	42	59	40	473	16-12 C50LO-S	16-12C50MLOSS	420	420
25	1	1 5/8-12	1 7/16-12	48	20.5	27.5	41	45	62	43	580	16-20 C50LO-S	16-20C50MLOSS	280	280
28, 30, 32	1 1/4	1 5/8-12	1 11/16-12	48	26.0	27.5	41	45	62	43	563	20 C50LO-S	20C50MLOSS	280	280
28, 30, 32	1 1/4	1 5/16-12	1 11/16-12	41	26.0	21.5	41	45	62	43	563	20-16 C50LO-S	20-16C50MLOSS	380	280
28, 30, 32	1 1/4	1 7/8-12	1 11/16-12	54	26.0	33.5	48	49	66	47	764	20-24 C50LO-S	20-24C50MLOSS	280	280
35, 38	1 1/2	1 7/8-12	2-12	54	32.0	33.5	48	49	66	47	689	24 C50LO-S	24C50MLOSS	280	280
35, 38	1 1/2	1 5/8-12	2-12	48	32.0	26.0	48	49	66	47	644	24-20 C50LO-S	24-20C50MLOSS	280	280

Product delivered with NBR TRAP seal. Replacement of TRAP seal is with a standard NBR O-ring – see page J73-J74.

Part numbers shown are part of our current manufacturing programme.

Imperial and metric parts may vary in hexagon dimensions.

$$\frac{\text{PN (bar)}}{10} = \text{PN (MPa)}$$

Do not create drawings from these dimensions, they are subject to change and ISO manufacturing allowances.

*JJ may vary in stainless steel

CC5OLO Extended male stud elbow

O-Lok® ORFS tube end / Male UN/UNF thread – O-ring (ISO 11926)
SAE 521520

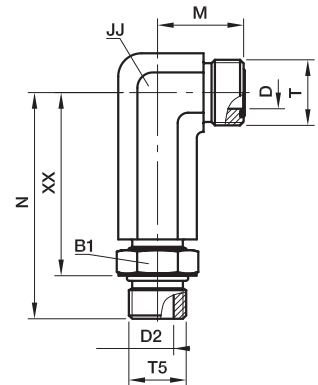

Tube O.D.		Thread UN/UNF-2A T5	Thread UN/UNF-2A T	B1	D	D2	JJ*	M	N	XX	Weight (steel) g/1 piece	O-Lok® Steel	PN (bar)
mm	in.			mm	mm	mm	mm	mm	mm	mm			
6	1/4	7/16-20	9/16-18	16	4.5	4.5	14	22	57	45	44	4 CC5OLO-S	420
8, 10	3/8	9/16-18	11/16-16	19	6.5	7.5	22	25	66	54	51	6 CC5OLO-S	420
12	1/2	3/4-16	13/16-16	24	9.5	10.0	22	28	75	61	146	8 CC5OLO-S	420
14, 15, 16	5/8	7/8-14	1-14	27	12.5	12.5	27	33	89	73	159	10 CC5OLO-S	420
18, 20	3/4	1 1/16-12	1 3/16-12	35	15.5	15.5	33	37	101	82	291	12 CC5OLO-S	420
25	1	1 5/16-12	1 7/16-12	41	20.5	21.5	41	42	115	96	481	16 CC5OLO-S	380

Product delivered with NBR TRAP seal. Replacement of TRAP seal is with a standard NBR O-ring – see page J73-J74.

Part numbers shown are part of our current manufacturing programme.

Imperial and metric parts may vary in hexagon dimensions.

$$\frac{PN \text{ (bar)}}{10} = PN \text{ (MPa)}$$

Do not create drawings from these dimensions, they are subject to change and ISO manufacturing allowances.

*JJ may vary in stainless steel

C4OMLO Male stud elbow

O-Lok® ORFS tube end / Male BSPP thread O-ring + retaining ring (ISO 1179)

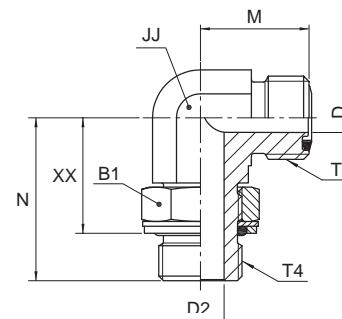

Tube O.D.		Thread BSPP T4	Thread UN/UNF-2A T	B1 mm	D mm	D2 mm	JJ* mm	M mm	N mm	XX mm	Weight (steel) g/1 piece	O-Lok® Steel	O-Lok® Stainless Steel	PN (bar)	
mm	in.													S	SS
6	1/4	1/8-28	9/16-18	14	4.5	4.4	14	22	30	21	49	4C4OMLOS	4C4OMLOSS	250	250
6	1/4	1/4-19	9/16-18	19	4.5	7.5	19	24	36	25	93	4-4C4OMLOS	4-4C4OMLOSS	250	200
6	1/4	3/8-19	9/16-18	22	4.5	9.9	19	25	38	27	99	4-6C4OMLOS	4-6C4OMLOSS	250	200
8, 10	3/8	1/4-19	11/16-16	19	6.5	7.5	19	25	36	25	97	6C4OMLOS	6C4OMLOSS	250	200
8, 10	3/8	1/8-28	11/16-16	14	6.5	4.4	19	25	32	23	62	6-2C4OMLOS	6-2C4OMLOSS	250	200
8, 10	3/8	3/8-19	11/16-16	22	6.5	9.9	19	27	38	27	106	6-6C4OMLOS	6-6C4OMLOSS	250	200
8, 10	3/8	1/2-14	11/16-16	27	6.5	12.3	27	29	49	35	120	6-8C4OMLOS	6-8C4OMLOSS	250	200
12	1/2	3/8-19	13/16-16	22	9.5	9.9	19	28	38	27	108	8C4OMLOS	8C4OMLOSS	250	200
12	1/2	1/4-19	13/16-16	19	9.5	7.5	19	28	36	25	99	8-4C4OMLOS	8-4C4OMLOSS	250	200
12	1/2	1/2-14	13/16-16	27	9.5	12.3	27	31	49	35	239	8-8C4OMLOS	8-8C4OMLOSS	250	200
12	1/2	3/4-14	13/16-16	36	9.5	15.5	30	34	52	38	258	8-12C4OMLOS	8-12C4OMLOSS	250	200
14, 15, 16	5/8	1/2-14	1-14	27	12.5	12.3	27	33	49	35	274	10C4OMLOS	10C4OMLOSS	250	200
14, 15, 16	5/8	3/8-19	1-14	22	12.5	9.9	27	33	43	32	235	10-6C4OMLOS	10-6C4OMLOSS	250	200
14, 15, 16	5/8	3/4-14	1-14	36	12.5	15.5	30	36	52	38	352	10-12C4OMLOS	10-12C4OMLOSS	250	200
14, 15, 16	5/8	1-11	1-14	41	12.5	21.5	36	40	58	42	382	10-16C4OMLOS	10-16C4OMLOSS	250	200
18, 20	3/4	3/4-14	1 3/16-12	36	15.5	15.5	30	37	52	38	355	12C4OMLOS	12C4OMLOSS	250	200
18, 20	3/4	1/2-14	1 3/16-12	27	15.5	12.3	30	37	50	36	297	12-8C4OMLOS	12-8C4OMLOSS	250	200
18, 20	3/4	1-11	1 3/16-12	41	15.5	21.5	36	41	58	42	362	12-16C4OMLOS	12-16C4OMLOSS	250	200
25	1	1-11	1 7/16-12	41	20.5	21.5	36	42	58	42	551	16C4OMLOS	16C4OMLOSS	250	200
25	1	3/4-14	1 7/16-12	36	20.5	15.5	36	42	55	42	533	16-12C4OMLOS	16-12C4OMLOSS	250	200
25	1	1 1/4-11	1 7/16-12	50	20.5	27.5	41	45	61	45	758	16-20C4OMLOS	16-20C4OMLOSS	210	160
28, 30, 32	1 1/4	1 1/4-11	1 11/16-12	50	26.0	27.5	41	45	61	45	752	20C4OMLOS	20C4OMLOSS	210	160
28, 30, 32	1 1/4	1-11	1 11/16-12	41	26.0	21.5	41	45	61	45	712	20-16C4OMLOS	20-16C4OMLOSS	250	200
28, 30, 32	1 1/4	1 1/2-11	1 11/16-12	55	26.0	33.0	50	49	65	48	821	20-24C4OMLOS	20-24C4OMLOSS	140	140
35, 28	1 1/2	1 1/2-11	2-12	55	32.0	33.0	50	49	65	48	953	24C4OMLOS	24C4OMLOSS	140	140
35, 38	1 1/2	1 1/4-11	2-12	50	32.0	27.5	50	49	65	46	1098	24-20C4OMLOS	24-20C4OMLOSS	140	140

Product delivered with NBR TRAP seal. Replacement of TRAP seal is with a standard NBR O-ring – see page J73-J74.

Part numbers shown are part of our current manufacturing programme.

Imperial and metric parts may vary in hexagon dimensions.

$$\frac{\text{PN (bar)}}{10} = \text{PN (MPa)}$$

Do not create drawings from these dimensions, they are subject to change and ISO manufacturing allowances.

*JJ may vary in stainless steel

C8OMLO Male stud elbow

O-Lok® ORFS tube end / Male metric thread – O-ring + retaining ring

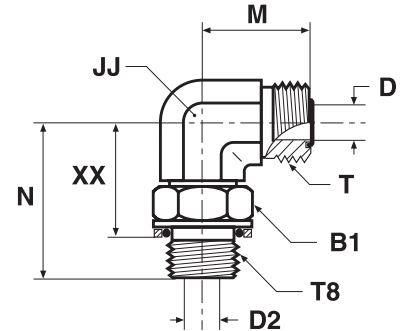

Tube O.D.		Thread metric T8	Thread UN/UNF-2A T	B1 mm	D mm	D2 mm	JJ* mm	M mm	N mm	XX mm	Weight (steel) g/1 piece	O-Lok® Steel	PN (bar)
mm	in.												
6	1/4	M 12×1.5	9/16-18	17	4.5	4	14	22	33	22	52	4M12C8OMLOS	250
6	1/4	M 14×1.5	9/16-18	17	4.5	6	14	24	36	24	58	4M14C8OMLOS	250
8, 10	3/8	M 14×1.5	11/16-16	17	6.5	6	19	25	36	25	62	6M14C8OMLOS	250
8, 10	3/8	M 16×1.5	11/16-16	19	6.5	7	19	25	38	24	65	6M16C8OMLOS	250
12	1/2	M 16×1.5	13/16-16	19	9.5	7	19	28	38	25	82	8M16C8OMLOS	250
12	1/2	M 18×1.5	13/16-16	22	9.5	9	19	28	41	25	161	8M18C8OMLOS	250
14, 15, 16	5/8	M 18×1.5	1-14	22	12.5	9	27	33	48	32	185	10M18C8OMLOS	250
14, 15, 16	5/8	M 22×1.5	1-14	27	12.5	12	27	33	49	31	214	10M22C8OMLOS	250
18, 20	3/4	M 22×1.5	1 3/16-12	27	15.5	12	30	37	50	31	322	12M22C8OMLOS	250
18, 20	3/4	M 27×2.0	1 3/16-12	32	15.5	15	30	37	56	35	440	12M27C8OMLOS	250
25	1	M 33×2.0	1 7/16-12	38	20.5	20	36	42	59	39	501	16M33C8OMLOS	140
28, 30, 32	1 1/4	M 42×2.0	1 11/16-12	50	26.0	26	41	45	63	42	561	20M42C8OMLOS	140
35, 38	1 1/2	M 48×2.0	2-12	55	32.0	32	50	49	72	47	684	24M48C8OMLOS	140

Product delivered with NBR TRAP seal. Replacement of TRAP seal is with a standard NBR O-ring – see page J73-J74.

Part numbers shown are part of our current manufacturing programme.

Imperial and metric parts may vary in hexagon dimensions.

$$\frac{\text{PN (bar)}}{10} = \text{PN (MPa)}$$

Do not create drawings from these dimensions, they are subject to change and ISO manufacturing allowances.

*JJ may vary in stainless steel

CLO Male stud elbow

O-Lok® ORFS tube end / Male NPTF* thread (SAE J476)

*Stainless Steel = NPT to prevent galling

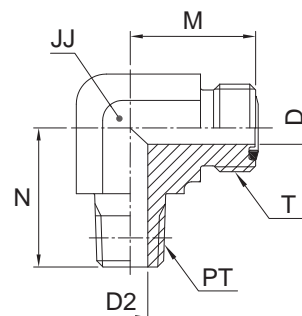

Tube O.D.		Thread NPTF PT	Thread UN/UNF-2A T	D mm	D2 mm	JJ* mm	M mm	N mm	Weight (steel) g/1 piece	O-Lok® Steel	O-Lok® Stainless Steel	PN (bar)	
mm	in.											S	SS
6	1/4	1/8-27	9/16-18	4.5	4.8	14	22	20	39	4 CLO-S	4 CLO-SS	420	420
6	1/4	1/4-18	9/16-18	4.5	7.1	14	22	28	50	4-4 CLO-S	4-4 CLO-SS	420	420
8, 10	3/8	1/4-18	11/16-16	6.5	7.1	19	25	28	75	6 CLO-S	6 CLO-SS	420	420
8, 10	3/8	3/8-18	11/16-16	6.5	10.3	19	25	31	81	6-6 CLO-S	6-6 CLO-SS	420	420
8, 10	3/8	1/2-14	11/16-16	6.5	13.5	22	29	37	84	6-8 CLO-S	6-8 CLO-SS	420	420
12	1/2	3/8-18	13/16-16	9.5	10.3	19	28	31	89	8 CLO-S	8 CLO-SS	420	420
12	1/2	1/2-14	13/16-16	9.5	13.5	22	28	37	125	8-8 CLO-S	8-8 CLO-SS	420	420
12	1/2	3/4-14	13/16-16	9.5	18.3	27	34	40	168	8-12 CLO-S	8-12 CLO-SS	280	280
14, 15, 16	5/8	1/2-14	1-14	12.5	13.5	27	33	37	154	10 CLO-S	10 CLO-SS	420	420
14, 15, 16	5/8	3/4-14	1-14	12.5	18.3	27	36	40	237	10-12 CLO-S	10-12 CLO-SS	280	280
18, 20	3/4	3/4-14	1 3/16-12	15.5	18.3	30	37	40	246	12 CLO-S	12 CLO-SS	280	280
18, 20	3/4	1/2-14	1 3/16-12	15.5	13.5	30	37	40	257	12-8 CLO-S	12-8 CLO-SS	420	420
18, 20	3/4	1-11.5	1 3/16-12	15.5	23.8	33	41	50	363	12-16 CLO-S	12-16 CLO-SS	210	210
25	1	1-11.5	1 7/16-12	20.5	23.8	36	42	50	387	16 CLO-S	16 CLO-SS	210	210
25	1	3/4-14	1 7/16-12	20.5	18.3	36	42	45	401	16-12 CLO-S	16-12 CLO-SS	280	280
28, 30, 32	1 1/4	1 1/4-11.5	1 11/16-12	26.0	31.8	41	45	61	469	20 CLO-S	20 CLO-SS	175	175
35, 38	1 1/2	1 1/2-11.5	2-12	32.0	38.1	48	49	67	603	24 CLO-S	24 CLO-SS	175	175

Product delivered with NBR TRAP seal. Replacement of TRAP seal is with a standard NBR O-ring – see page J73-J74.

Part numbers shown are part of our current manufacturing programme.

Imperial and metric parts may vary in hexagon dimensions.

$$\frac{\text{PN (bar)}}{10} = \text{PN (MPa)}$$

Do not create drawings from these dimensions, they are subject to change and ISO manufacturing allowances.

*JJ may vary in stainless steel

V87OMLO 45° male stud elbow

O-Lok® ORFS tube end / Male metric thread – O-ring (ISO 6149-2)
 SAE 52M0387 ISO 8434-3 SDE45

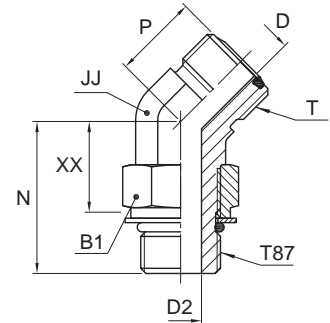

Tube O.D.		Thread metric T87	Thread UN/UNF-2A T	B1 mm	D mm	D2 mm	JJ* mm	P mm	N mm	XX mm	Weight (steel) g/1 piece	O-Lok® Steel	O-Lok® Stainless Steel	PN (bar)	
mm	in.													S	SS
6	1/4	M 12×1.5	9/16-18	17	4.5	4	14	16	30	19	44	4M12V87OMLOS	4M12V87OMLOSS	420	420
8, 10	3/8	M 16×1.5	11/16-16	22	6.5	7	19	19	33	20	82	6M16V87OMLOS	6M16V87OMLOSS	420	420
12	1/2	M 18×1.5	13/16-16	24	9.5	9	19	20	37	22	110	8M18V87OMLOS	8M18V87OMLOSS	420	420
14, 15, 16	5/8	M 22×1.5	1-14	27	12.5	12	27	23	44	29	190	10M22V87OMLOS	10M22V87OMLOSS	420	420
	3/4	M 27×2.0	1 3/16-12	32	15.5	15	30	26	50	31	288	12M27V87OMLOS	12M27V87OMLOSS	420	420
25	1	M 33×2.0	1 7/16-12	41	20.5	20	36	30	52	33	300	16M33V87OMLOS	16M33V87OMLOSS	420	420
28, 30, 32	1 1/4	M 42×2.0	1 11/16-12	50	26.0	26	41	32	54	35	444	20M42V87OMLOS	20M42V87OMLOSS	280	280
35, 38	1 1/2	M 48×2.0	2-12	55	32.0	32	50	37	56	35	569	24M48V87OMLOS		280	—

Product delivered with NBR TRAP seal. Replacement of TRAP seal is with a standard NBR O-ring – see page J73-J74.

Part numbers shown are part of our current manufacturing programme.

Imperial and metric parts may vary in hexagon dimensions.

$$\frac{PN \text{ (bar)}}{10} = PN \text{ (MPa)}$$

Do not create drawings from these dimensions, they are subject to change and ISO manufacturing allowances.

*JJ may vary in stainless steel

V5OMLO 45° male stud elbow

O-Lok® ORFS tube end / Adjustable UN/UNF thread O-ring (ISO 11926)
SAE 520320

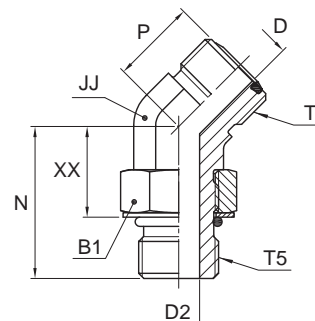

Tube O.D.		Thread UN/UNF-2A T5	Thread UN/UNF-2A T	B1 mm	D mm	D2 mm	JJ* mm	P mm	N mm	XX mm	Weight (steel) g/1 piece	O-Lok® Steel	O-Lok® Stainless Steel	PN (bar)	
mm	in.													S	SS
6	1/4	7/16-20	9/16-18	17	4.5	4.5	14	16	30	19	45		4V5OMLOSS	420	
6	1/4	7/16-20	9/16-18	16	4.5	4.5	14	16	30	19	45	4 V5OLO-S		630	
6	1/4	9/16-18	9/16-18	19	4.5	7.5	19	17	33	20	76	4-6 V5OLO-S	4-6V5OMLOSS	630	420
8, 10	3/8	9/16-18	11/16-16	19	6.5	7.5	19	19	33	20	83	6 V5OLO-S	6V5OMLOSS	630	420
8, 10	3/8	7/16-20	11/16-16	16	6.5	4.5	19	19	31	20	64	6-4 V5OLO-S	6-4V5OMLOSS	630	420
8, 10	3/8	3/4-16	11/16-16	24	6.5	10.0	19	19	36	22	96	6-8 V5OLO-S	6-8V5OMLOSS	630	420
12	1/2	3/4-16	13/16-16	24	9.5	10.0	19	20	36	23	117	8 V5OLO-S	8V5OMLOSS	630	420
12	1/2	9/16-18	13/16-16	19	9.5	7.5	19	20	32	20	71	8-6 V5OLO-S	8-6V5OMLOSS	630	420
12	1/2	7/8-14	13/16-16	27	9.5	12.5	19	21	45	22	147	8-10 V5OLO-S	8-10V5OMLOSS	420	420
14, 15, 16	5/8	7/8-14	1-14	27	12.5	12.5	27	23	45	28	194	10 V5OLO-S	10V5OMLOSS	420	420
14, 15, 16	5/8	3/4-16	1-14	24	12.5	10.0	27	23	40	26	192	10-8 V5OLO-S	10-8V5OMLOSS	420	420
14, 15, 16	5/8	1 1/16-12	1-14	35	12.5	15.5	30	24	50	31	207	10-12 V5OLO-S	10-12V5OMLOSS	420	420
18, 20	3/4	1 1/16-12	1 3/16-12	35	15.5	15.5	30	26	50	31	294	12V5OMLO-S	12V5OMLOSS	420	420
18, 20	3/4	7/8-14	1 3/16-12	27	15.5	12.5	30	26	46	29	219	12-10 V5OLO-S	12-10V5OMLOSS	420	420
18, 20	3/4	1 5/16-12	1 3/16-12	41	15.5	21.5	36	30	52	33	322	12-16 V5OLO-S	12-16V5OMLOSS	420	380
22, 25	1	1 5/16-12	1 7/16-12	41	20.5	21.5	36	30	52	33	394	16V5OMLOS	16V5OMLOSS	420	380
22, 25	1	1 1/16-12	1 7/16-12	36	20.5	15.5	36	30	52	33	337		16-12V5OMLOSS	420	420
22, 25	1	1 1/16-12	1 7/16-12	35	20.5	15.5	36	30	52	33	337	16-12 V5OLO-S		420	
22, 25	1	1 5/8-12	1 7/16-12	48	20.5	27.5	41	32	54	35	511	16-20 V5OLO-S	16-20V5OMLOSS	420	280
28, 30, 32	1 1/4	1 5/8-12	1 11/16-12	48	26.0	27.5	41	32	54	35	447	20 V5OLO-S	20V5OMLOSS	350	280
35, 38	1 1/2	1 7/8-12	2-12	54	32.0	33.5	48	37	54	35	571	24 V5OLO-S	24V5OMLOSS	280	280

Product delivered with NBR TRAP seal. Replacement of TRAP seal is with a standard NBR O-ring – see page J73-J74.

Part numbers shown are part of our current manufacturing programme.

Imperial and metric parts may vary in hexagon dimensions.

$$\frac{\text{PN (bar)}}{10} = \text{PN (MPa)}$$

Do not create drawings from these dimensions, they are subject to change and ISO manufacturing allowances.

*JJ may vary in stainless steel

J

V4OMLO 45° male stud elbow

O-Lok® ORFS tube end / Adjustable BSPP thread O-ring + retaining ring (ISO 1179)

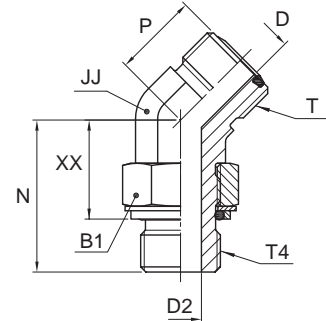

Tube O.D.		Thread BSPP T4	Thread UN/UNF-2A T	B1 mm	D mm	D2 mm	JJ* mm	P mm	N mm	XX mm	Weight (steel) g/1 piece	O-Lok®		PN (bar)	
mm	in.											Steel	Stainless Steel	S	SS
6	1/4	1/8-28	9/16-18	14	4.5	4.4	14	16	28	18	38	4V40MLOS	4V40MLOSS	250	250
6	1/4	1/4-19	9/16-18	19	4.5	7.5	19	17	33	22	43	4-4V40MLOS	4-4V40MLOSS	250	200
8, 10	3/8	1/4-19	11/16-16	19	6.5	7.5	19	19	32	20	83	6V40MLOS	6V40MLOSS	250	200
8, 10	3/8	3/8-19	11/16-16	22	6.5	9.9	19	19	34	22	95	6-6V40MLOS	6-6V40MLOSS	250	200
8, 10	3/8	1/2-14	11/16-16	27	6.5	12.3	27	19	43	29	107	6-8V40MLOS	6-8V40MLOSS	250	200
12	1/2	3/8-19	13/16-16	22	9.5	9.9	19	20	34	22	117	8V40MLOS	8V40MLOSS	250	200
12	1/2	1/2-14	13/16-16	27	9.5	12.3	27	21	43	30	196	8-8V40MLOS	8-8V40MLOSS	250	200
14, 15, 16	5/8	1/2-14	1-14	27	12.5	12.3	27	23	43	29	191	10V40MLOS	10V40MLOSS	250	200
14, 15, 16	5/8	3/4-14	1-14	36	12.5	15.5	30	24	46	32	227	10-12V40MLOS	10-12V40MLOSS	250	200
18, 20	3/4	3/4-14	1 3/16-12	36	15.5	15.5	30	26	46	32	294	12V40MLOS	12V40MLOSS	250	200
18, 20	3/4	1-11	1 3/16-12	41	15.5	21.5	36	30	51	34	325	12-16V40MLOS	12-16V40MLOSS	250	200
25	1	1-11	1 7/16-12	41	20.5	21.5	36	30	51	34	394	16V40MLOS	16V40MLOSS	250	200
28, 30, 32	1 1/4	1 1/4-11	1 11/16-12	50	26.0	27.5	41	32	52	37	430	20V40MLOS	20V40MLOSS	210	160
35, 38	1 1/2	1 1/2-11	2-12	55	32.0	33.0	50	37	52	37	551	24V40MLOS	24V40MLOSS	140	140

Product delivered with NBR TRAP seal. Replacement of TRAP seal is with a standard NBR O-ring – see page J73-J74.

Part numbers shown are part of our current manufacturing programme.

Imperial and metric parts may vary in hexagon dimensions.

$$\frac{\text{PN (bar)}}{10} = \text{PN (MPa)}$$

Do not create drawings from these dimensions, they are subject to change and ISO manufacturing allowances.

*JJ may vary in stainless steel

V8OMLO 45° male stud elbow

O-Lok® ORFS tube end / Male metric thread – O-ring + retaining ring

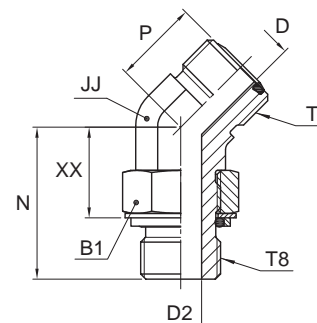

Tube O.D.		Thread metric T8	Thread UN/UNF-2A T	B1 mm	D mm	D2 mm	JJ* mm	P mm	N mm	XX mm	Weight (steel) g/1 piece	O-Lok® Steel	PN (bar)
mm	in.												
6	1/4	M 12×1.5	9/16-18	17	4.5	4	14	16	30	19	44	4M12V8OMLOS	250
10	3/8	M 16×1.5	11/16-16	19	6.5	7	19	19	33	19	82	6M16V8OMLOS	250
12	1/2	M 14×1.5	13/16-16	17	9.5	6	19	20	32	21	92	8M14V8OMLOS	250
12	1/2	M 18×1.5	13/16-16	22	9.5	9	19	20	37	21	110	8M18V8OMLOS	250
14, 15, 16	5/8	M 18×1.5	1-14	22	12.5	9	27	24	43	27	160	10M18V8OMLOS	250
14, 15, 16	5/8	M 22×1.5	1-14	27	12.5	12	27	23	44	27	190	10M22V8OMLOS	250
18, 20	3/4	M 27×2.0	1 3/16-12	32	15.5	15	30	26	50	30	288	12M27V8OMLOS	250
25	1	M 33×2.0	1 7/16-12	38	20.5	20	36	30	52	32	300	16M33V8OMLOS	140
28, 30, 32	1 1/4	M 42×2.0	1 11/16-12	50	26.0	26	41	32	54	33	444	20M42V8OMLOS	140
35, 38	1 1/2	M 48×2.0	2-12	55	32.0	32	50	37	56	32	568	24M48V8OMLOS	140

Product delivered with NBR TRAP seal. Replacement of TRAP seal is with a standard NBR O-ring – see page J73-J74.

Part numbers shown are part of our current manufacturing programme.

Imperial and metric parts may vary in hexagon dimensions.

$$\frac{\text{PN (bar)}}{10} = \text{PN (MPa)}$$

Do not create drawings from these dimensions, they are subject to change and ISO manufacturing allowances.

*JJ may vary in stainless steel

J

S87OMLO Male stud branch tee

O-Lok® ORFS tube ends / Adjustable metric thread – O-ring (ISO 6149)
 SAE 52M0489 ISO 8434-3 SDBT

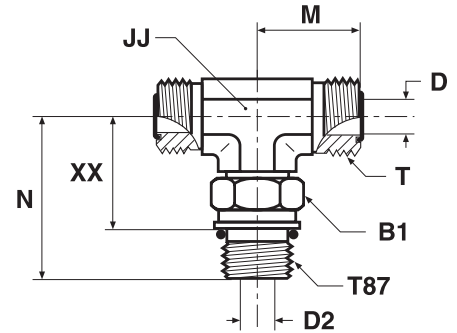

Tube O.D.		Thread metric T87	Thread UN/UNF-2A T	B1 mm	D mm	D2 mm	JJ* mm	M mm	N mm	XX mm	Weight (steel) g/1 piece	O-Lok®		PN (bar)	
mm	in.											Steel	Stainless Steel	S	SS
6	1/4	M 12×1.5	9/16-18	17	4.5	4	14	22	33	21	66	4M12S87OMLOS	4M12S87OMLOSS	420	420
8, 10	3/8	M 16×1.5	11/16-16	22	6.5	7	19	25	37	24	131	6M16S87OMLOS	6M16S87OMLOSS	420	420
12	1/2	M 18×1.5	13/16-16	24	9.5	9	19	28	41	26	187	8M18S87OMLOS	8M18S87OMLOSS	420	420
14, 15, 16	5/8	M 22×1.5	1-14	27	12.5	12	27	33	49	33	283	10M22S87OMLOS	10M22S87OMLOSS	420	420
18, 20	3/4	M 27×2.0	1 3/16-12	32	15.5	15	30	37	55	36	549	12M27S87OMLOS	12M27S87OMLOSS	420	420
25	1	M 33×2.0	1 7/16-12	41	20.5	20	36	42	59	41	565	16M33S87OMLOS	16M33S87OMLOSS	420	420
28, 30, 32	1 1/4	M 42×2.0	1 11/16-12	50	26.0	26	41	45	62	43	824	20M42S87OMLOS	20M42S87OMLOSS	280	280
35, 38	1 1/2	M 48×2.0	2-12	55	32.0	32	48	49	69	50	940	24M48S87OMLOS	24M48S87OMLOSS	280	—

Product delivered with NBR TRAP seal. Replacement of TRAP seal is with a standard NBR O-ring – see page J73-J74.

Part numbers shown are part of our current manufacturing programme.

Imperial and metric parts may vary in hexagon dimensions.

$$\frac{\text{PN (bar)}}{10} = \text{PN (MPa)}$$

Do not create drawings from these dimensions, they are subject to change and ISO manufacturing allowances.

*JJ may vary in stainless steel

S50MLO Male stud branch tee

O-Lok® ORFS tube end / Adjustable UN/UNF thread O-ring (ISO 11926)
SAE 520429

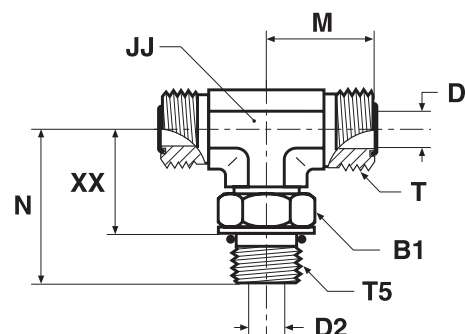

Tube O.D.		Thread UN/UNF-2A T5	Thread UN/UNF-2A T	B1 mm	D mm	D2 mm	JJ* mm	M mm	N mm	XX mm	Weight (steel) g/1 piece	O-Lok® Steel	O-Lok® Stainless Steel	PN (bar)	
mm	in.													S	SS
6	1/4	7/16-20	9/16-18	16	4.5	4.5	14	22	33	21	67	4 S50LO-S	4 S50LO-SS	420	420
8, 10	3/8	9/16-18	11/16-16	19	6.5	7.5	19	25	37	24	131	6S50MLOS	6 S50LO-SS	420	420
12	1/2	3/4-16	13/16-16	24	9.5	10.0	19	28	41	26	187	8 S50LO-S	8 S50LO-SS	420	420
14, 15, 16	5/8	7/8-14	1-14	27	12.5	12.5	27	33	50	33	279	10 S50LO-S	10 S50LO-SS	420	420
18, 20	3/4	1 1/16-12	1 3/16-12	35	15.5	15.5	30	37	55	36	441	12 S50LO-S	12 S50LO-SS	420	420
25	1	1 5/16-12	1 7/16-12	41	20.5	21.5	37	42	60	41	539	16 S50LO-S	16 S50LO-SS	380	380
28, 30, 32	1 1/4	1 5/8-12	1 11/16-12	48	26.0	27.5	41	45	62	43	851	20 S50LO-S		280	—
35, 38	1 1/2	1 7/8-12	2-12	54	32.0	33.5	48	49	66	47	942	24 S50LO-S		280	—

Product delivered with NBR TRAP seal. Replacement of TRAP seal is with a standard NBR O-ring – see page J73-J74.

Part numbers shown are part of our current manufacturing programme.

Imperial and metric parts may vary in hexagon dimensions.

$$\frac{\text{PN (bar)}}{10} = \text{PN (MPa)}$$

Do not create drawings from these dimensions, they are subject to change and ISO manufacturing allowances.

*JJ may vary in stainless steel.

J

S4OMLO Male stud branch tee

O-Lok® ORFS tube end / Adjustable BSPP thread O-ring + retaining ring (ISO 1179)

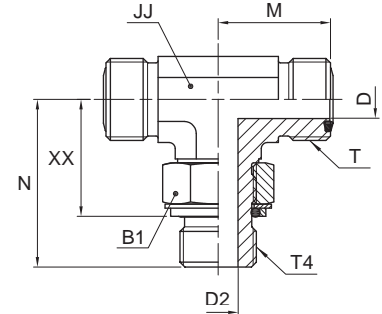

Tube O.D.		Thread BSPP T4	Thread UN/UNF-2A T	B1 mm	D mm	D2 mm	JJ* mm	M mm	N mm	XX mm	Weight (steel) g/1 piece	O-Lok®		PN (bar)	
mm	in.											Steel	Stainless Steel	S	SS
6	1/4	1/8-28	9/16-18	14	4.5	4.4	14	22	30	21	69	4S4OMLOS	4S4OMLOSS	250	250
6	1/4	1/4-19	9/16-18	19	4.5	7.5	19	24	36	25	97	4-4-4S4OMLOS	4-4-4S4OMLOSS	250	200
8, 10	3/8	1/4-19	11/16-16	19	6.5	7.5	19	25	36	25	127	6S4OMLOS	6S4OMLOSS	250	200
8, 10	3/8	3/8-19	11/16-16	22	6.5	9.9	19	27	38	27	126	6-6-6S4OMLOS	6-6-6S4OMLOSS	250	200
12	1/2	3/8-19	13/16-16	22	9.5	9.9	19	28	38	27	146	8S4OMLOS	8S4OMLOSS	250	200
12	1/2	1/2-14	13/16-16	27	9.5	12.3	27	31	49	35	174	8-8-8S4OMLOS	8-8-8S4OMLOSS	250	200
14, 15, 16	5/8	1/2-14	1-14	27	12.5	12.3	27	33	49	35	288	10S4OMLOS	10S4OMLOSS	250	200
14, 15, 16	5/8	3/4-14	1-14	36	12.5	15.5	30	36	52	38	314	10-10-12S4OMLOS	10-10-12S4OMLOSS	250	200
18, 20	3/4	3/4-14	1 3/16-12	36	15.5	15.5	30	37	52	38	531	12S4OMLOS	12S4OMLOSS	250	200
22, 25	1	1-11	1 7/16-12	41	20.5	21.5	36	42	58	42	600	16S4OMLOS	16S4OMLOSS	250	200
28, 30, 32	1 1/4	1 1/4-11	1 11/16-12	50	26.0	27.5	41	45	61	45	850	20S4OMLOS	20S4OMLOSS	210	160
35, 38	1 1/2	1 1/2-11	2-12	55	32.0	33.0	50	49	65	50	940	24S4OMLOS		140	—

Product delivered with NBR TRAP seal. Replacement of TRAP seal is with a standard NBR O-ring – see page J73-J74.

Part numbers shown are part of our current manufacturing programme.

Imperial and metric parts may vary in hexagon dimensions.

$$\frac{PN \text{ (bar)}}{10} = PN \text{ (MPa)}$$

Do not create drawings from these dimensions, they are subject to change and ISO manufacturing allowances.

*JJ may vary in stainless steel.

S8OMLO Male stud branch tee

O-Lok® ORFS tube end / Adjustable metric thread – O-ring + retaining ring

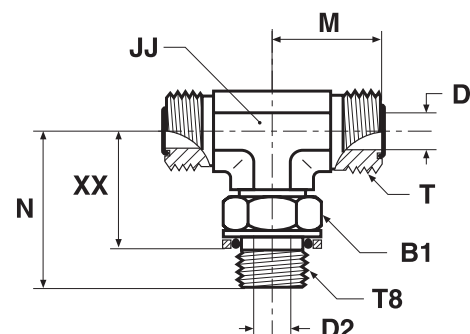

Tube O.D.		Thread metric T8	Thread UN/UNF-2A T	B1 mm	D mm	D2 mm	JJ* mm	M mm	N mm	XX mm	Weight (steel) g/1 piece	O-Lok® Steel	PN (bar)
mm	in.												
6	1/4	M 12×1.5	9/16-18	17	4.5	4	14	22	33	22	66	4M12S8OMLOS	250
8, 10	3/8	M 16×1.5	11/16-16	19	6.5	7	19	25	38	24	131	6M16S8OMLOS	250
12	1/2	M 18×1.5	13/16-16	22	9.5	9	19	28	41	25	187	8M18S8OMLOS	250
14, 15, 16	5/8	M 22×1.5	1-14	27	12.5	12	27	33	49	31	283	10M22S8OMLOS	250
18, 20	3/4	M 27×2.0	1 3/16-12	32	15.5	15	30	37	55	35	550	12M27S8OMLOS	250
25	1	M 33×2.0	1 7/16-12	38	20.5	20	36	42	59	39	566	16M33S8OMLOS	140
28, 30, 32	1 1/4	M 42×2.0	1 11/16-12	50	26.0	26	41	45	62	41	824	20M42S8OMLOS	140
35, 38	1 1/2	M 48×2.0	2-12	55	32.0	32	48	49	72	47	940	24M48S8OMLOS	140

Product delivered with NBR TRAP seal. Replacement of TRAP seal is with a standard NBR O-ring – see page J73-J74.

Part numbers shown are part of our current manufacturing programme.

Imperial and metric parts may vary in hexagon dimensions.

$$\frac{\text{PN (bar)}}{10} = \text{PN (MPa)}$$

Do not create drawings from these dimensions, they are subject to change and ISO manufacturing allowances.

*JJ may vary in stainless steel.

J

R87OMLO Male stud run tee

O-Lok® ORFS tube ends / Adjustable metric thread – O-ring (ISO 6149)
 SAE 52M0488 ISO 8434-3 SDRT

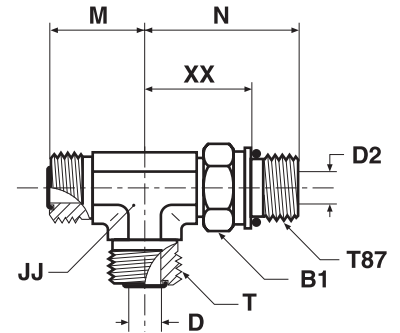

Tube O.D.		Thread metric T87	Thread UN/UNF-2A T	B1 mm	D mm	D2 mm	JJ* mm	M mm	N mm	XX mm	Weight (steel) g/1 piece	O-Lok® Steel	O-Lok® Stainless Steel	PN (bar)	
mm	in.													S	SS
6	1/4	M 12×1.5	9/16-18	17	4.5	4	14	22	33	21	66	4M12R87OMLOS	4M12R87OMLOSS	420	420
6	1/4	M 14×1.5	11/16-16	19	6.5	6	19	25	36	21	129	6M14R87OMLOS	6M14R87OMLOSS	420	420
8, 10	3/8	M 16×1.5	11/16-16	22	6.5	7	19	25	38	24	131	6M16R87OMLOS	6M16R87OMLOSS	420	420
12	1/2	M 18×1.5	13/16-16	24	9.5	9	19	28	41	26	187	8M18R87OMLOS	8M18R87OMLOSS	420	420
14, 15, 16	5/8	M 22×1.5	1-14	27	12.5	12	27	33	49	33	283	10M22R87OMLOS	10M22R87OMLOSS	420	420
18, 20	3/4	M 27×2.0	1 3/16-12	32	15.5	15	30	37	55	36	549	12M27R87OMLOS	12M27R87OMLOSS	420	420
25	1	M 33×2.0	1 7/16-12	41	20.5	20	36	42	59	41	565	16M33R87OMLOS	16M33R87OMLOSS	420	420
28, 30, 32	1 1/4	M 42×2.0	1 11/16-12	50	26.0	26	41	45	63	43	824	20M42R87OMLOS	20M42R87OMLOSS	280	280
35, 38	1 1/2	M 48×2.0	2-12	55	32.0	32	48	49 ^{*1}	69	50	940	24M48R87OMLOS	24M48R87OMLOSS	280	—

Product delivered with NBR TRAP seal. Replacement of TRAP seal is with a standard NBR O-ring – see page J73-J74.

Part numbers shown are part of our current manufacturing programme.

Imperial and metric parts may vary in hexagon dimensions.

$$\frac{\text{PN (bar)}}{10} = \text{PN (MPa)}$$

Do not create drawings from these dimensions, they are subject to change and ISO manufacturing allowances.

*JJ may vary in stainless steel.

*1M=52 in stainless steel.

R50MLO Male stud run tee

O-Lok® ORFS tube end / Adjustable UN/UNF thread O-ring (ISO 11926)
SAE 520428

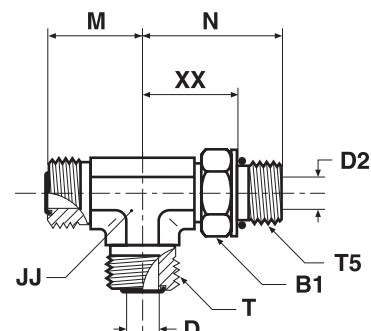

Tube O.D.		Thread UN/UNF-2A T5	Thread UN/UNF-2A T	B1 mm	D mm	D2 mm	JJ* mm	M mm	N mm	XX mm	Weight (steel) g/1 piece	O-Lok® Steel	O-Lok® Stainless Steel	PN (bar)	
mm	in.													S	SS
6	1/4	7/16-20	9/16-18	16	4.5	4.5	14	22	33	21	67	4 R50LO-S	4 R50LO-SS	420	420
6	1/4	9/16-18	9/16-18	19	4.5	4.0	19	24	37	24	133	4-6-4R50MLOS	4-6-4 R0LO-SS	420	420
8, 10	3/8	9/16-18	11/16-16	19	6.5	6.5	19	25	37	24	131	6 R50LO-S	6 R50LO-SS	420	420
12	1/2	3/4-16	13/16-16	24	9.5	9.5	19	28	41	26	187	8 R50LO-S	8 R50LO-SS	420	420
12	1/2	7/8-14	13/16-16	27	9.5	12.5	27	32	50	26	286	8-10-8 R50LO-S	8-10-8 R50LO-SS	420	420
14, 15, 16	5/8	7/8-14	1-14	27	12.5	12.5	27	33	50	33	288	10 R50LO-S	10 R50LO-SS	420	420
18, 20	3/4	1 1/16-12	1 3/16-12	36	15.5	15.5	30	37	55	36	558	12R50MLOS	12 R50LO-SS	420	420
18, 20	3/4	1 5/16-12	1 3/16-12	41	15.5	21.5	36	41	60	41	560	12-16-12 R50LO-S	12-16-12 R50LO-SS	380	380
25	1	1 5/16-12	1 7/16-12	41	20.5	20.5	36	42	60	41	566	16 R50LO-S	16 R50LO-SS	380	380
28, 30, 32	1 1/4	1 5/8-12	1 11/16-12	48	26.0	27.5	41	45	62	43	825	20 R50LO-S	20 R50LO-SS	280	280
35, 38	1 1/2	1 7/8-12	2-12	54	32.0	32.0	48	49 ^{*1}	66	47	942	24 R50LO-S	24 R50LO-SS	280	280

Product delivered with NBR TRAP seal. Replacement of TRAP seal is with a standard NBR O-ring – see page J73-J74.

Part numbers shown are part of our current manufacturing programme.

Imperial and metric parts may vary in hexagon dimensions.

$$\frac{\text{PN (bar)}}{10} = \text{PN (MPa)}$$

Do not create drawings from these dimensions, they are subject to change and ISO manufacturing allowances.

*JJ may vary in stainless steel.

*1M=52 in stainless steel.

J

R40MLO Male stud run tee

O-Lok® ORFS tube ends / Adjustable BSPP thread O-ring + retaining ring (ISO 1179)

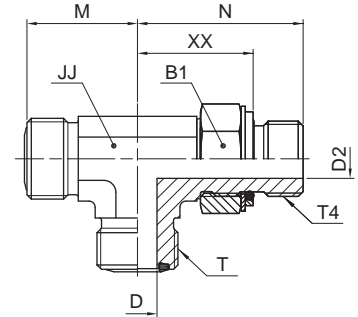

Tube O.D.		Thread BSPP T4	Thread UN/UNF-2A T	B1 mm	D mm	D2 mm	JJ* mm	M mm	N mm	XX mm	Weight (steel) g/1 piece	O-Lok®		PN (bar)	
mm	in.											Steel	Stainless Steel	S	SS
6	1/4	1/8-28	9/16-18	14	4.5	4.5	14	22	30	20	69	4R40MLOS	4R40MLOSS	250	250
6	1/4	1/4-19	9/16-18	19	4.5	7.5	19	24	36	25	97	4-4-4R40MLOS	4-4-4R40MLOSS	250	200
8, 10	3/8	1/4-19	11/16-16	19	6.5	7.5	19	25	36	25	127	6R40MLOS	6R40MLOSS	250	200
8, 10	3/8	3/8-19	11/16-16	22	6.5	9.9	19	27	38	27	126	6-6-6R40MLOS	6-6-6R40MLOSS	250	200
12	1/2	3/8-19	13/16-16	22	9.5	9.9	19	28	38	27	146	8R40MLOS	8R40MLOSS	250	200
12	1/2	1/2-14	13/16-16	27	9.5	12.3	27	31	49	33	174	8-8-8R40MLOS	8-8-8R40MLOSS	250	200
14, 15, 16	5/8	1/2-14	1-14	27	12.5	12.3	27	33	49	33	288	10R40MLOS	10R40MLOSS	250	200
18, 20	3/4	3/4-14	1 3/16-12	36	15.5	15.5	30	37	52	36	531	12R40MLOS	12R40MLOSS	250	200
18, 20	3/4	1-11	1 3/16-12	41	15.5	21.5	36	41	58	40	559	12-16-12R40MLOS	12-16-12R40MLOSS	250	200
25	1	1-11	1 7/16-12	41	20.5	21.5	36	42	58	40	553	16R40MLOS	16R40MLOSS	250	200
28, 30, 32	1 1/4	1 1/4-11	1 11/16-12	50	26.0	27.5	41	45	61	42	824	20R40MLOS	20R40MLOSS	210	160
35, 38	1 1/2	1 1/2-11	2-12	55	32.0	32.0	50	49 ^{*1}	65	48	940	24R40MLOS	24R40MLOSS	140	—

Product delivered with NBR TRAP seal. Replacement of TRAP seal is with a standard NBR O-ring – see page J73-J74.

Part numbers shown are part of our current manufacturing programme.

Imperial and metric parts may vary in hexagon dimensions.

$$\frac{PN \text{ (bar)}}{10} = PN \text{ (MPa)}$$

Do not create drawings from these dimensions, they are subject to change and ISO manufacturing allowances.

*JJ may vary in stainless steel.

*¹M=52 in stainless steel.

R8OMLO Male stud run tee

O-Lok® ORFS tube end / Adjustable metric thread – O-ring + retaining ring

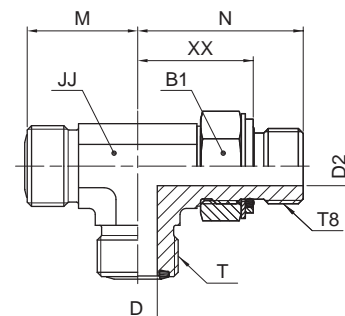

Tube O.D.		Thread metric T8	Thread UN/UNF-2A T	B1 mm	D mm	D2 mm	JJ* mm	M mm	N mm	XX mm	Weight (steel) g/1 piece	O-Lok® Steel	PN (bar)
mm	in.												
6	1/4	M 12×1.5	9/16-18	17	4.5	4	14	22	33	22	66	4M12R8OMLOS	250
8, 10	3/8	M 16×1.5	11/16-16	19	6.5	7	19	25	38	24	131	6M16R8OMLOS	250
12	1/2	M 18×1.5	13/16-16	22	9.5	9	19	28	41	25	187	8M18R8OMLOS	250
14, 15, 16	5/8	M 22×1.5	1-14	27	12.5	12	27	33	49	31	283	10M22R8OMLOS	250
18, 20	3/4	M 27×2.0	1 3/16-12	32	15.5	15	30	37	55	35	550	12M27R8OMLOS	250
25	1	M 33×2.0	1 7/16-12	38	20.5	20	36	42	59	39	566	16M33R8OMLOS	140
28, 30, 32	1 1/4	M 42×2.0	1 11/16-12	50	26.0	26	41	45	62	41	824	20M42R8OMLOS	140
35, 38	1 1/2	M 48×2.0	2-12	55	32.0	32	48	49 ¹	72	47	940	24M48R8OMLOS	140

Product delivered with NBR TRAP seal. Replacement of TRAP seal is with a standard NBR O-ring – see page J73-J74.

Part numbers shown are part of our current manufacturing programme.

Imperial and metric parts may vary in hexagon dimensions.

$$\frac{\text{PN (bar)}}{10} = \text{PN (MPa)}$$

Do not create drawings from these dimensions, they are subject to change and ISO manufacturing allowances.

*JJ may vary in stainless steel.

*1M=52 in stainless steel.

G87MLO Pressure gauge connector

O-Lok® ORFS tube end / Female metric thread – O-ring (ISO 6149-1) suitably for EMA link

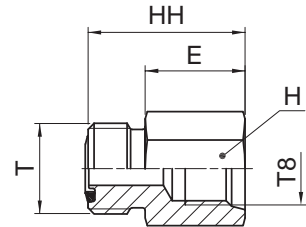

Tube O.D. mm	Tube O.D. in.	Thread metric T8	Thread UN/UNF-2A T	E mm	H mm	HH mm	Weight (steel) g/1 piece	O-Lok®	O-Lok®	PN (bar)	
								Steel	Stainless Steel	S	SS
6	1/4	M 14x1.5	9/16-18	19	19	29	20	4M14G87MLOS	4M14G87MLOSS	630	630
8, 10	3/8	M 14x1.5	11/16-18	19	19	30	44	6M14G87MLOS	6M14G87MLOSS	630	630
12	1/2	M 14x1.5	13/16-16	19	22	32	66	8M14G87MLOS	8M14G87MLOSS	630	630
14, 15, 16	5/8	M 14x1.5	1-14	19	27	35	82	10M14G87MLOS	10M14G87MLOSS	420	420
18, 20	3/4	M 14x1.5	1 3/16-12	19	32	36	104	12M14G87MLOS	12M14G87MLOSS	420	420

Product delivered with NBR TRAP seal. Replacement of TRAP seal is with a standard NBR O-ring – see page J73-J74.

Part numbers shown are part of our current manufacturing programme.

Imperial and metric parts may vary in hexagon dimensions.

$$\frac{\text{PN (bar)}}{10} = \text{PN (MPa)}$$

Do not create drawings from these dimensions, they are subject to change and ISO manufacturing allowances.

G4MLOSMO Pressure gauge connector

O-Lok® ORFS tube end / Female BSPP gauge thread (ISO 1179-1)

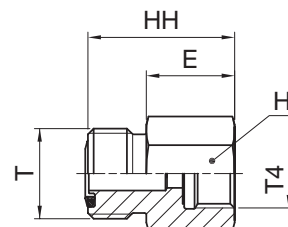

Tube O.D. mm	Tube O.D. in.	Thread BSPP T4	Thread UN/UNF-2A T	E mm	H mm	HH mm	Weight (steel) g/1 piece	O-Lok®		PN (bar)	
								Steel	Stainless Steel	S	SS
6	1/4	1/4-19	9/16-18	18	17	27	32	4-4G4MLOSMO	4-4G4MLOSSMO	400	400
6	1/4	1/2-14	9/16-18	27	30	37	80	4-8G4MLOSMO	4-8G4MLOSSMO	400	400
8, 10	3/8	1/4-19	11/16-16	17	19	28	49	6G4MLOSMO	6G4MLOSSMO	400	400
8, 10	3/8	1/2-14	11/16-16	27	30	38	107	6-8G4MLOSMO	6-8G4MLOSSMO	400	400
12	1/2	1/4-19	13/16-16	17	22	30	60	8-4G4MLOSMO	8-4G4MLOSSMO	280	280
12	1/2	1/2-14	13/16-16	27	30	40	80	8-8G4MLOSMO	8-8G4MLOSSMO	280	280

Product delivered with NBR TRAP seal. Replacement of TRAP seal is with a standard NBR O-ring – see page J73-J74.

Part numbers shown are part of our current manufacturing programme.

Imperial and metric parts may vary in hexagon dimensions.

$$\frac{\text{PN (bar)}}{10} = \text{PN (MPa)}$$

Do not create drawings from these dimensions, they are subject to change and ISO manufacturing allowances.

J

TT4ML Test point connector

O-Lok® ORFS swivel female end / Female BSPP thread (ISO 1179-1)
for EMA3 test point

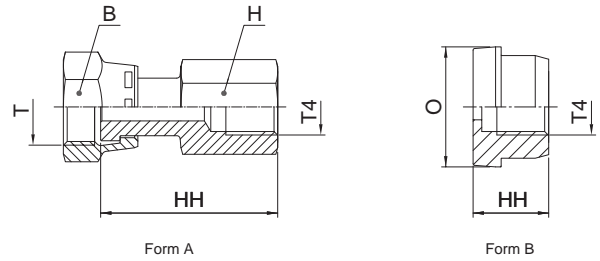

Form B has to be assembled with a nut BMLS/BLS.

Thread UN/UNF-2B T	Thread BSPP T4	O mm	B mm	H mm	HH mm	Weight (steel) g/1 piece	Form	O-Lok®		PN (bar)	
								Steel	Stainless Steel	S	SS
9/16-18	1/4-19	—	17	19	38	60	A	4TT4MLS	4TT4MLSS	420	420
11/16-16	1/4-19	—	22	19	41	74	A	6TT4MLS	6TT4MLSS	420	420
13/16-16	1/4-19	—	24	19	43	91	A	8TT4MLS	8TT4MLSS	420	420
—	1/4-19	23	—	—	18	30	B	10TT4LS	10TT4MLSS	420	420
—	1/4-19	28	—	—	18	48	B	12TT4LS	12TT4MLSS	420	420
—	1/4-19	34	—	—	18	95	B	16TT4LS	16TT4MLSS	420	420
—	1/4-19	41	—	—	18	130	B	20TT4LS	20TT4MLSS	280	280
—	1/4-19	48	—	—	18	189	B	24TT4LS	24TT4MLSS	280	280

Part numbers shown are part of our current manufacturing programme.

Imperial and metric parts may vary in hexagon dimensions.

$$\frac{\text{PN (bar)}}{10} = \text{PN (MPa)}$$

Do not create drawings from these dimensions, they are subject to change and ISO manufacturing allowances.

TT8ML Test point connector

O-Lok® ORFS female swivel end / Metric female thread
(Metric female thread designed for use with EMA3 connections only)

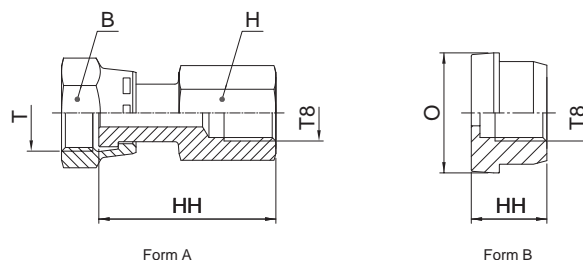

Form B has to be assembled with a nut BMLS/BLS.

Thread UN/UNF-2B T	Thread metric T8	O mm	B mm	H mm	HH mm	Weight (steel) g/1 piece	Form	O-Lok® Steel	O-Lok® Stainless Steel	PN (bar)	
										S	SS
9/16-18	M 10×1.0	—	17	19	38	86	A	4TT8MLS	4TT8MLSS	420	420
11/16-16	M 10×1.0	—	22	19	39	86	A	6TT8MLS	6TT8MLSS	420	420
13/16-16	M 10×1.0	—	24	19	43	123	A	8TT8MLS	8TT8MLSS	420	420
—	M 10×1.0	23	—	—	16	40	B	10TT8LS	10TT8LSS	420	420
—	M 10×1.0	28	—	—	16	60	B	12TT8LS	12TT8LSS	420	420
—	M 10×1.0	34	—	—	16	85	B	16TT8LS	16TT8LSS	420	420
—	M 10×1.0	41	—	—	16	133	B	20TT8LS	20TT8LSS	280	280
—	M 10×1.0	48	—	—	16	193	B	24TT8LS	24TT8LSS	280	280

Part numbers shown are part of our current manufacturing programme.

Imperial and metric parts may vary in hexagon dimensions.

$$\frac{\text{PN (bar)}}{10} = \text{PN (MPa)}$$

Do not create drawings from these dimensions, they are subject to change and ISO manufacturing allowances.

TTP4ML Test point connector

O-Lok® ORFS female swivel end / EMA3 test point

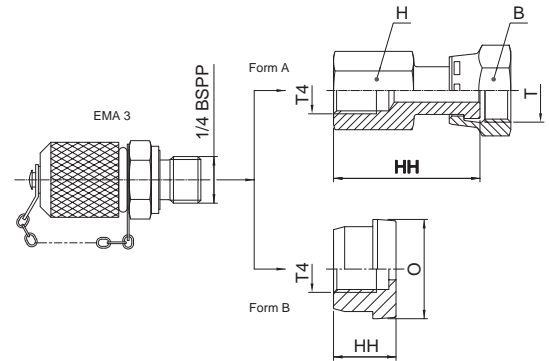

Form B versions delivered complete with BMLS nut.

Thread UN/UNF-2B T	Thread BSPP T4	O mm	B mm	H mm	HH mm	Weight (steel) g/1 piece	Form	O-Lok® Steel	PN (bar)
9/16-18	1/4-19	—	17	19	38	150	A	4TTP4MLS	420
11/16-16	1/4-19	—	22	19	41	164	A	6TTP4MLS	420
13/16-16	1/4-19	—	24	19	43	181	A	8TTP4MLS	420
—	1/4-19	23	30	—	18	120	B	10TTP4LS	420
—	1/4-19	28	36	—	18	138	B	12TTP4LS	420
—	1/4-19	34	41	—	18	185	B	16TTP4LS	420
—	1/4-19	41	50	—	18	200	B	20TTP4LS	280
—	1/4-19	49	60	—	18	279	B	24TTP4LS	280

O-Lok® is delivered with NBR elastomeric seals as standard. For more details on other seal materials see page J73-J74.

Part numbers shown are part of our current manufacturing programme.

Imperial and metric parts may vary in hexagon dimensions.

$$\frac{\text{PN (bar)}}{10} = \text{PN (MPa)}$$

Do not create drawings from these dimensions, they are subject to change and ISO manufacturing allowances.

R6P4MLO Test point connector

O-Lok® ORFS end / O-Lok® ORFS female swivel end / EMA3 test point

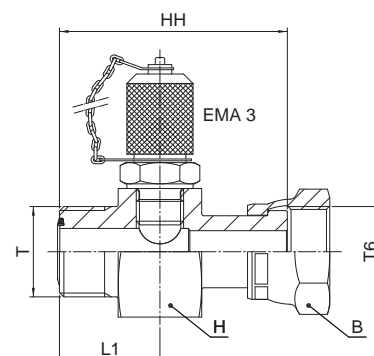

Tube O.D.		Thread UN/UNF-2A T	Thread UN/UNF-2B T6	HH mm	L1 mm	H mm	B mm	Weight (steel) g/1 piece	O-Lok® Steel	PN (bar)
mm	in.									
6	1/4	9/16-18	9/16-18	50	22	36	17	270	4-4R6P4MLOS	420
8, 10	3/8	11/16-16	11/16-16	53	23	36	22	300	6-4R6P4MLOS	420
12	1/2	13/16-16	13/16-16	58	25	36	24	308	8-4R6P4MLOS	420
14, 15, 16	5/8	1-14	1-14	64	27	36	30	337	10-4R6P4MLOS	420
18, 20	3/4	1 3/16-12	1 3/16-12	68	29	41	36	416	12-4R6P4MLOS	420
22, 25	1	1 7/16-12	1 7/16-12	71	29	46	41	506	16-4R6P4MLOS	420
28, 30, 32	1 1/4	1 11/16-12	1 11/16-12	73	29	50	50	691	20-4R6P4MLOS	280
35, 38	1 1/2	2-12	2-12	74	29	60	60	995	24-4R6P4MLOS	280

Product delivered with NBR TRAP seal. Replacement of TRAP seal is with a standard NBR O-ring – see page J73-J74.

Part numbers shown are part of our current manufacturing programme.

Imperial and metric parts may vary in hexagon dimensions.

$$\frac{\text{PN (bar)}}{10} = \text{PN (MPa)}$$

Do not create drawings from these dimensions, they are subject to change and ISO manufacturing allowances.

J

LOHB3* Braze connector

O-Lok® ORFS tube end / Braze socket
 SAE 520104 / SAE 52M0104 ISO 8434-3 BRS
 (*Parts delivered oil dipped finish only – steel)

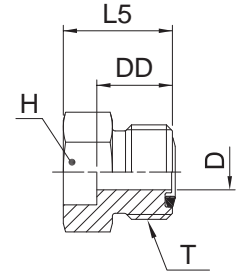

Tube O.D.		Thread UN/UNF-2A T	D mm	DD mm	H in.	H mm	L5 mm	Weight (steel) g/1 piece	O-Lok® Steel	O-Lok® Stainless Steel	PN (bar)	
mm	in.										S	SS
6		9/16-18	4.5	14	—	17	22	23	4-6MMLOHB3S		420	—
		9/16-18	4.5	13	5/8	—	22	24	4 LOHB3-S	4 LOHB3-SS	420	420
		9/16-18	4.5	13	5/8	—	22	23	4-6 LOHB3-S	4-6 LOHB3-SS	420	420
		11/16-16	6.5	14	3/4	—	23	36	6 LOHB3-S	6 LOHB3-SS	420	420
		11/16-16	6.5	14	3/4	—	23	42	6-4 LOHB3-S	6-4 LOHB3-SS	420	420
		11/16-16	6.5	14	3/4	—	23	36	6-8 LOHB3-S	6-8 LOHB3-SS	420	420
		11/16-16	6.5	15	3/4	—	23	30	6-10 LOHB3-S	6-10 LOHB3-SS	420	420
	11/16-16	6.5	15	—	—	19	23	6-10MMLOHB3S		420	—	
12		13/16-16	9.5	16	—	22	25	42	8-12MMLOHB3S		420	—
		13/16-16	9.5	16	7/8	—	25	44	8 LOHB3-S	8 LOHB3-SS	420	420
		13/16-16	9.5	16	7/8	—	25	58	8-4 LOHB3-S	8-4 LOHB3-SS	420	420
		13/16-16	9.5	16	7/8	—	25	43	8-6 LOHB3-S	8-6 LOHB3-SS	420	420
		13/16-16	9.5	16	7/8	—	25	42	8-10 LOHB3-S	8-10 LOHB3-SS	420	420
		13/16-16	9.5	17	1 1/16	—	30	74	8-12 LOHB3-S	8-12 LOHB3-SS	420	420
16		1-14	12.5	19	—	—	28	101	10-16MMLOHB3S		420	—
		1-14	12.5	19	1 1/16	—	27	104	10 LOHB3-S	10 LOHB3-SS	420	420
		1-14	12.5	19	1 1/16	—	27	99	10-6 LOHB3-S	10-6 LOHB3-SS	420	420
		1-14	12.5	19	1 1/16	—	27	96	10-8 LOHB3-S	10-8 LOHB3-SS	420	420
		1-14	12.5	19	1 1/16	—	31	97	10-12 LOHB3-S	10-12 LOHB3-SS	420	420
20		1 3/16-12	15.5	21	—	32	34	144	12-20MMLOHB3S		420	—
		1 3/16-12	15.5	21	1 1/4	—	34	149	12 LOHB3-S	12 LOHB3-SS	420	420
		1 3/16-12	15.5	21	1 1/4	—	30	174	12-8 LOHB3-S	12-8 LOHB3-SS	420	420
		1 3/16-12	15.5	21	1 1/4	—	30	171	12-10 LOHB3-S	12-10 LOHB3-SS	420	420
		1 3/16-12	15.5	21	1 1/2	—	35	220	12-16 LOHB3-S	12-16 LOHB3-SS	420	420
25		1 7/16-12	20.5	25	—	41	39	218	16-25MMLOHB3S		420	—
		1 7/16-12	20.5	25	1 1/2	—	39	225	16 LOHB3-S	16 LOHB3-SS	420	420
		1 7/16-12	20.5	25	1 1/2	—	33	237	16-8 LOHB3-S	16-8 LOHB3-SS	420	420
		1 7/16-12	20.5	25	1 1/2	—	37	228	16-12 LOHB3-S	16-12 LOHB3-SS	420	420
		1 7/16-12	20.5	25	1 3/4	—	39	276	16-20 LOHB3-S	16-20 LOHB3-SS	420	420
30		1 11/16-12	26.0	25	—	46	39	269	20-30MMLOHB3S		280	—
		1 11/16-12	26.0	25	1 3/4	—	39	278	20 LOHB3-S	20 LOHB3-SS	280	280
		1 11/16-12	26.0	25	1 3/4	—	39	278	20-16 LOHB3-S	20-16 LOHB3-SS	280	280
		1 11/16-12	26.0	25	2 1/8	—	39	371	20-24 LOHB3-S	20-24 LOHB3-SS	280	280
38		2-12	32.0	25	—	55	39	374	24-38MMLOHB3S		280	—
		2-12	32.0	25	2 1/8	—	39	384	24 LOHB3-S	24 LOHB3-SS	280	280
		2-12	32.0	25	2 1/8	—	39	442	24-20 LOHB3-S	24-20 LOHB3-SS	280	280

Product delivered with NBR TRAP seal. Replacement of TRAP seal is with a standard NBR O-ring – see page J73-J74.

Part numbers shown are part of our current manufacturing programme.

Imperial and metric parts may vary in hexagon dimensions.

$$\frac{\text{PN (bar)}}{10} = \text{PN (MPa)}$$

Do not create drawings from these dimensions, they are subject to change and ISO manufacturing allowances.

FNML Cap

O-Lok® ORFS Female swivel cap end
SAE 520112

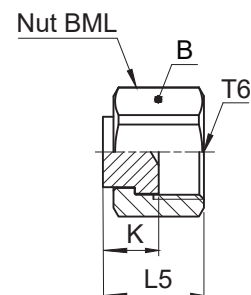

Thread UN/UNF-2B T6	B mm	K mm	L5 mm	Weight (steel) g/1 piece	O-Lok® Steel	O-Lok® Stainless Steel	PN (bar)	
							S	SS
9/16-18	17	9	16	6	4FNMLS	4FNMLSS	630	630
11/16-16	22	11	20	10	6FNMLS	6FNMLSS	630	630
13/16-16	24	12	22	11	8FNMLS	8FNMLSS	630	630
1-14	30	14	26	31	10FNMLS	10FNMLSS	420	420
1 3/16-12	36	15	29	52	12FNMLS	12FNMLSS	420	420
1 7/16-12	41	16	30	81	16FNMLS	16FNMLSS	420	420
1 11/16-12	48	16	30	129	20 FNL-S	20FNMLSS	280	280
2-12	57	16	30	189	24 FNL-S	24FNMLSS	280	280

Part numbers shown are part of our current manufacturing programme.

Imperial and metric parts may vary in hexagon dimensions.

$$\frac{\text{PN (bar)}}{10} = \text{PN (MPa)}$$

Do not create drawings from these dimensions, they are subject to change and ISO manufacturing allowances.

J

PNMLO Plug

O-Lok® ORFS tube end plug
SAE 520109

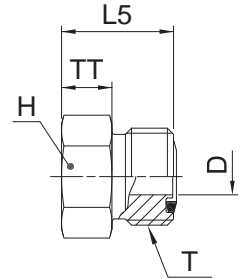

Tube O.D.		Thread UN/UNF-2A T	D mm	H mm	L5 mm	TT mm	Weight (steel) g/1 piece	O-Lok® Steel	O-Lok® Stainless Steel	PN (bar)	
mm	in.									S	SS
6	1/4	9/16-18	4.5	16	17	7	18	4 PNLO-S	4PNMLOSS	630	630
8, 10	3/8	11/16-16	6.5	19	19	8	34	6PNMLOS	6PNMLOSS	630	630
12	1/2	13/16-16	9.5	22	22	9	45	8PNMLOS	8PNMLOSS	630	630
14, 15, 16	5/8	1-14	12.5	27	26	10	91	10 PNLO-S	10PNMLOSS	420	420
18, 20	3/4	1 3/16-12	15.5	32	27	10	138	12 PNLO-S	12PNMLOSS	420	420
22, 25	1	1 7/16-12	20.5	38	28	10	203	16 PNLO-S	16PNMLOSS	420	420
28, 30, 32	1 1/4	1 11/16-12	26.0	45	28	10	266	20 PNLO-S	20PNMLOSS	420	280
35, 38	1 1/2	2-12	32.0	54	28	10	369	24 PNLO-S	24PNMLOSS	350	280

Product delivered with NBR TRAP seal. Replacement of TRAP seal is with a standard NBR O-ring – see page J73-J74.

Part numbers shown are part of our current manufacturing programme.

Imperial and metric parts may vary in hexagon dimensions.

$$\frac{PN \text{ (bar)}}{10} = PN \text{ (MPa)}$$

Do not create drawings from these dimensions, they are subject to change and ISO manufacturing allowances.

XHMLO Conversion union

Triple-Lok® 37° flare tube end / O-Lok® ORFS tube end

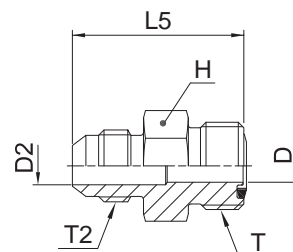

Tube O.D. mm	Tube O.D. in.	Thread UN/UNF-2A T	Thread UN/UNF-2A T2	D mm	D2 mm	L5 mm	H mm	Weight (steel) g/1 piece	O-Lok® Steel	O-Lok® Stainless Steel	PN (bar)	
											S	SS
6	1/4	9/16-18	7/16-20	4.5	4.5	32	16	29	4 XHLO-S	4XHMLOSS	500	350
8, 10	3/8	11/16-16	9/16-18	6.5	7.5	34	19	45	6 XHLO-S	6XHMLOSS	420	350
12	1/2	13/16-16	3/4-16	9.5	9.9	39	22	70	8 XHLO-S	8XHMLOSS	420	350
14, 15, 16	5/8	1-14	7/8-14	12.5	12.5	47	27	119	10 XHLO-S	10XHMLOSS	350	350
18, 20	3/4	1 3/16-12	1 1/16-12	15.5	15.5	52	32	181	12 XHLO-S	12XHMLOSS	350	350
22, 25	1	1 7/16-12	1 5/16-12	20.5	20.5	55	38	265	16 XHLO-S	16XHMLOSS	280	280
28, 30, 32	1 1/4	1 11/16-12	1 5/8-12	26.0	26.0	58	45	383	20 XHLO-S	20XHMLOSS	280	210
35, 38	1 1/2	2-12	1 7/8-12	32.0	32.0	63	54	562	24 XHLO-S	24XHMLOSS	210	140

Product delivered with NBR TRAP seal. Replacement of TRAP seal is with a standard NBR O-ring – see page J73-J74.

Part numbers shown are part of our current manufacturing programme.

Imperial and metric parts may vary in hexagon dimensions.

$$\frac{\text{PN (bar)}}{10} = \text{PN (MPa)}$$

Do not create drawings from these dimensions, they are subject to change and ISO manufacturing allowances.

J

XHML6 Conversion swivel nut connector

Triple-Lok® 37° flare tube end / O-Lok® ORFS female swivel end

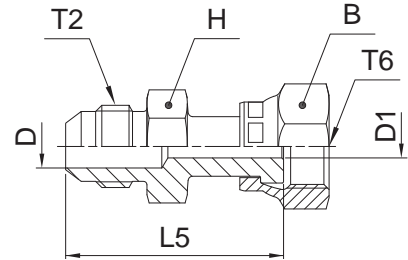

Tube O.D.		Thread UN/UNF-2A T2	Thread UN/UNF-2B T6	B	D1	D	L5	H	Weight (steel)	O-Lok® Steel	O-Lok® Stainless Steel	PN (bar)	
mm	in.			mm	mm	mm	mm	mm	g/1 piece			S	SS
6	1/4	7/16-20	9/16-18	18	4.2	4.2	38	16	29	4 XHL6-S	4XHML6SS	500	350
8, 10	3/8	9/16-18	11/16-16	21	6.7	6.7	41	19	46	6 XHL6-S	6XHML6SS	420	350
12	1/2	3/4-16	13/16-16	24	9.1	9.1	48	22	73	8 XHL6-S	8XHML6SS	420	350
14, 15, 16	5/8	7/8-14	1-14	29	11.5	11.5	56	27	126	10 XHL6-S	10XHML6SS	350	350
18, 20	3/4	1 1/16-12	1 3/16-12	35	14.0	14.0	64	32	205	12 XHL6-S	12XHML6SS	350	350
22, 25	1	1 5/16-12	1 7/16-12	41	19.9	19.9	68	38	285	16 XHL6-S	16XHML6SS	280	280
28, 30, 32	1 1/4	1 5/8-12	1 11/16-12	48	26.0	26.0	71	43	623	20 XHL6-S	20XHML6SS	280	210

Part numbers shown are part of our current manufacturing programme.

Imperial and metric parts may vary in hexagon dimensions.

$$\frac{PN \text{ (bar)}}{10} = PN \text{ (MPa)}$$

Do not create drawings from these dimensions, they are subject to change and ISO manufacturing allowances.

LOHMX6 Conversion swivel nut connector

Triple-Lok® 37 flare female swivel end / O-Lok® ORFS male end

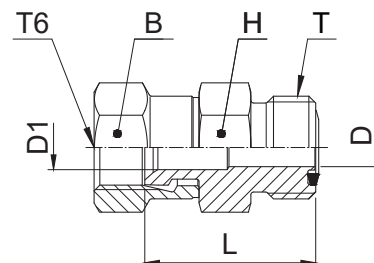

Tube O.D.		Thread UN/UNF-2A T	Thread UN/UNF-2B T6	B	D	D1	H	L	Weight (steel)	O-Lok® Steel	O-Lok® Stainless Steel	PN (bar)	
mm	in.			mm	mm	mm	mm	mm	g/1 piece			S	SS
6	1/4	9/16-18	7/16-20	14	4.5	4.5	16	24	26	4 LOHX6-S	4LOHMX6SS	500	350
8, 10	3/8	11/16-16	9/16-18	18	6.5	6.5	19	29	40	6 LOHX6-S	6LOHMX6SS	350	350
12	1/2	13/16-16	3/4-16	22	9.5	9.5	22	34	63	8 LOHX6-S	8LOHMX6SS	350	350
14, 15, 16	5/8	1-14	7/8-14	25	12.5	12.5	27	39	103	10 LOHX6-S	10LOHMX6SS	350	350
18, 20	3/4	1 3/16-12	1 1/16-12	32	15.5	15.5	32	41	162	12 LOHX6-S	12LOHMX6SS	350	350
22, 25	1	1 7/16-12	1 5/16-12	38	20.5	20.5	38	46	229	16 LOHX6-S	16LOHMX6SS	250	250

Product delivered with NBR TRAP seal. Replacement of TRAP seal is with a standard NBR O-ring – see page J73-J74.

Part numbers shown are part of our current manufacturing programme.

Imperial and metric parts may vary in hexagon dimensions.

$$\frac{\text{PN (bar)}}{10} = \text{PN (MPa)}$$

Do not create drawings from these dimensions, they are subject to change and ISO manufacturing allowances.

J

LOHU86 EO swivel adapter

O-Lok® ORFS tube end / EO 24° DKO swivel

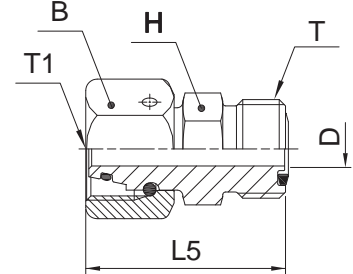

Tube O.D.		EO Swivel Size	Thread UN/UNF-2A T	Thread metric T1	H mm	D mm	L5 mm	B mm	Weight (steel) g/1 piece	O-Lok® Steel	PN (bar)
mm	in.										
6	1/4	6L	9/16-18	M 12×1.5	17	2.6	34	14	30	4-6L LOHU86-S	500
6	1/4	8L	9/16-18	M 14×1.5	17	4.1	34	17	50	4-8L LOHU86-S	500
8, 10	3/8	10L	11/16-16	M 16×1.5	19	6.1	37	19	75	6-10L LOHU86-S	500
12	1/2	12L	13/16-16	M 18×1.5	22	8.2	39	22	145	8-12L LOHU86-S	400
14, 15 16	5/8	15L	1-14	M 22×1.5	27	10.2	46	27	180	10-15L LOHU86-S	400
18, 20	3/4	18L	1 3/16-12	M 26×1.5	32	13.2	48	32	250	12-18L LOHU86-S	400
22, 25	1	22L	1 7/16-12	M 30×2.0	41	17.2	53	36	305	16-22L LOHU86-S	250
6	1/4	6S	9/16-18	M 14×1.5	17	2.6	34	17	30	4-6S LOHU86-S	630
6	1/4	8S	9/16-18	M 16×1.5	17	4.1	34	19	50	4-8S LOHU86-S	630
8, 10	3/8	10S	11/16-16	M 18×1.5	19	6.0	37	22	75	6-10S LOHU86-S	630
12	1/2	12S	13/16-16	M 20×1.5	22	8.0	40	24	145	8-12S LOHU86-S	630
14, 15, 16	5/8	14S	1-14	M 22×1.5	27	9.2	47	27	180	10-14S LOHU86-S	420
14, 15, 16	5/8	16S	1-14	M 24×1.5	27	11.2	47	30	185	10-16S LOHU86-S	420
18, 20	3/4	20S	1 3/16-12	M 30×2.0	32	14.1	52	36	260	12-20S LOHU86-S	420
22, 25	1	25S	1 7/16-12	M 36×2.0	41	18.2	55	46	308	16-25S LOHU86-S	420

Product delivered with NBR TRAP seal. Replacement of TRAP seal is with a standard NBR O-ring – see page J73-J74.

Part numbers shown are part of our current manufacturing programme.

Imperial and metric parts may vary in hexagon dimensions.

$$\frac{\text{PN (bar)}}{10} = \text{PN (MPa)}$$

Do not create drawings from these dimensions, they are subject to change and ISO manufacturing allowances.

FNLBA Bleed adaptor

O-Lok® ORFS female end

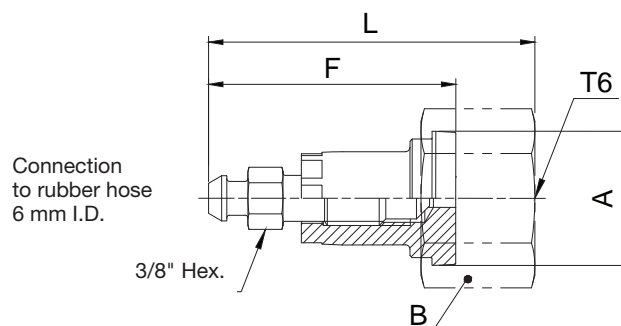

Thread UN/UNF-2B T6	A mm	F mm	B mm	L mm	Weight (steel) g/1 piece	O-Lok®		PN (bar)	
						Steel	Stainless Steel	S	SS
13/16-16	19	41	24	53	49	8 FNLBA-S	8 FNLBA-SS	630	630
1-14	23	41	29	55	77	10 FNLBA-S	10 FNLBA-SS	420	420
1 3/16-12	28	41	35	56	111	12 FNLBA-S	12 FNLBA-SS	420	420
1 7/16-12	34	41	41	56	113	16 FNLBA-S	16 FNLBA-SS	420	420
1 11/16-12	41	41	48	56	151	20 FNLBA-S	20 FNLBA-SS	420	420
2-12	49	41	57	56	161	24 FNLBA-S	24 FNLBA-SS	420	350

Part numbers shown are part of our current manufacturing programme.

Imperial and metric parts may vary in hexagon dimensions.

$$\frac{\text{PN (bar)}}{10} = \text{PN (MPa)}$$

Do not create drawings from these dimensions, they are subject to change and ISO manufacturing allowances.

J

PNLOBA Bleed adaptor

O-Lok® ORFS female end

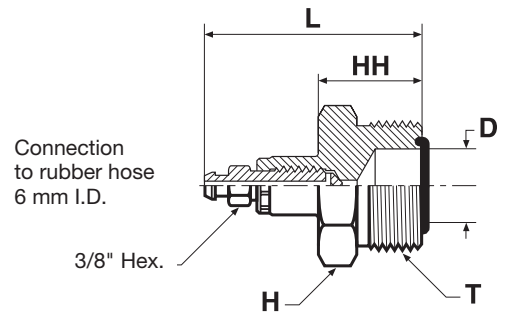

Tube O.D.		Thread UN/UNF-2A T	D mm	H mm	HH mm	L mm	Weight (steel) g/1 piece	O-Lok® Steel	PN (bar)
mm	in.								
6	1/4	9/16-18	4.5	18	20	48	57	4 PNLOBA-S	630
8, 10	3/8	11/16-16	6.5	19	22	50	64	6 PNLOBA-S	630
12	1/2	13/16-16	9.5	22	23	53	93	8 PNLOBA-S	630
14, 15, 16	5/8	1-14	12.5	27	26	56	127	10 PNLOBA-S	420
18, 20	3/4	1 3/16-12	15.5	32	27	58	220	12 PNLOBA-S	420
22, 25	1	1 7/16-12	20.5	38	28	60	266	16 PNLOBA-S	420
28, 30, 32	1 1/4	1 11/16-12	26.0	45	28	61	304	20 PNLOBA-S	420
35, 38	1 1/2	2-12	32.0	54	28	63	422	24 PNLOBA-S	350

Product delivered with NBR TRAP seal. Replacement of TRAP seal is with a standard NBR O-ring – see page J73-J74.

Part numbers shown are part of our current manufacturing programme.

Imperial and metric parts may vary in hexagon dimensions.

$$\frac{\text{PN (bar)}}{10} = \text{PN (MPa)}$$

Do not create drawings from these dimensions, they are subject to change and ISO manufacturing allowances.

HPBA Bleed adaptor

Bleed hose connection / Male NPTF thread (SAE J476)

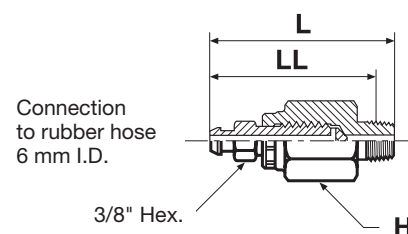

Thread NPTF	H mm	L mm	LL mm	O-Lok® Steel	PN (bar)
1/4-18	18	56	47	1/4 HPBA-S	420

Imperial and metric parts may vary in hexagon dimensions.

$$\frac{\text{PN (bar)}}{10} = \text{PN (MPa)}$$

Do not create drawings from these dimensions, they are subject to change and ISO manufacturing allowances.

J

P5ONBA Bleed adaptor

Bleed hose connection/Male UN/UNF thread – O-ring (ISO 11926)

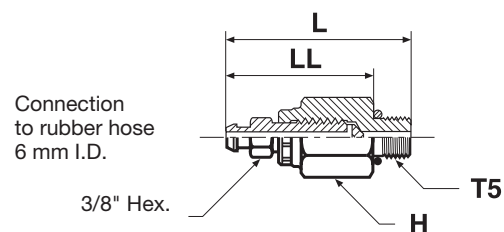

Thread UN/UNF-2A T5	H mm	L mm	LL mm	O-Lok® Steel	PN (bar)
7/16-20	18	52	41	4 P5ONBA-S	420

O-Lok® is delivered with NBR elastomeric seals as standard. For more details on other seal materials see page J73-J74.

Part numbers shown are part of our current manufacturing programme.

Imperial and metric parts may vary in hexagon dimensions.

$$\frac{\text{PN (bar)}}{10} = \text{PN (MPa)}$$

Do not create drawings from these dimensions, they are subject to change and ISO manufacturing allowances.

TW3L Weld nipple

O-Lok® ORFS female end / Butt weld end

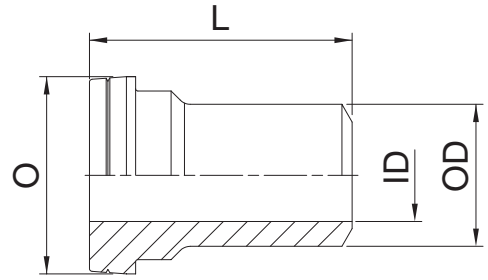

Tube O.D. mm	ID mm	OD mm	O mm	L mm	Weight (steel) g/1 piece	O-Lok® Steel	O-Lok® Stainless Steel
6	2	6	13	25	10	TW3LS6	TW3LSS6
8	3	8	13	25	12	TW3LS8	TW3LSS8
10	4	10	16	26	15	TW3LS10	TW3LSS10
12	5	12	19	26	18	TW3LS12	TW3LSS12
16	10	16	23	32	25	TW3LS16	TW3LSS16
20	13	20	28	37	30	TW3LS20	TW3LSS20
25	16	25	34	42	37	TW3LS25	TW3LSS25
30	22	30	41	44	43	TW3LS30	TW3LSS30
38	28	38	48	49	70	TW3LS38	TW3LSS38

Part numbers shown are part of our current manufacturing programme.

Do not create drawings from these dimensions, they are subject to change and ISO manufacturing allowances.

WLNML Bulkhead locknut

SAE 520118/SAE 52M0118 ISO 8434-3 BHLN

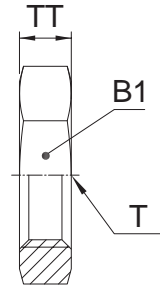

Thread UN/UNF-2B T	B1 mm	TT mm	Weight (steel) g/1 piece	O-Lok® Steel	O-Lok® Stainless Steel
9/16-18	22	7	11	4WLNMLS	4WLNMLSS
11/16-16	27	8	23	6WLNMLS	6WLNMLSS
13/16-16	30	9	26	8WLNMLS	8WLNMLSS
1-14	36	11	38	10WLNMLS	10WLNMLSS
1 3/16-12	41	11	44	12WLNMLS	12WLNMLSS
1 7/16-12	46	11	54	16WLNMLS	16WLNMLSS
1 11/16-12	51	10	73	20 WLNLS-S	20WLNMLSS
2-12	60	10	102	24 WLNLS-S	24WLNMLSS

Part numbers shown are part of our current manufacturing programme.

Imperial and metric parts may vary in hexagon dimensions.

Do not create drawings from these dimensions, they are subject to change and ISO manufacturing allowances.

Spare parts guide – O-Lok® retaining rings and seals

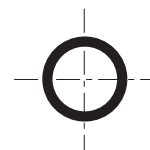

Face seal end O-rings SAE J1453/ISO 8434-3

Dash size	Thread UN/UNF	O-ring order code		O-ring ID × section mm
		NBR	FKM	
4	9/16-18	2-011-N552-9	2-011-V894-9	7.65 × 1.78
6	11/16-16	2-012-N552-9	2-012-V894-9	9.25 × 1.78
8	13/16-16	2-014-N552-9	2-014-V894-9	12.42 × 1.78
10	1-14	2-016-N552-9	2-016-V894-9	15.60 × 1.78
12	1 3/16-12	2-018-N552-9	2-018-V894-9	18.77 × 1.78
16	1 7/16-12	2-021-N552-9	2-021-V894-9	23.52 × 1.78
20	1 11/16-12	2-025-N552-9	2-025-V894-9	29.87 × 1.78
24	2-12	2-029-N552-9	2-029-V894-9	37.82 × 1.78

BSPP male threads – ISO 1179

Thread BSPP	ED seal order code		O-ring order code*		O-ring ID × section mm	Retainer ring Order code Steel	Retainer ring Order code Stainless Steel
	NBR	FKM	NBR	FKM			
1/8	ED10X1X	ED10X1VITX	6-002-N552-9	6-002-V894-9	8.00 × 2.00	8207-1/8	8207SS1/8
1/4	ED14X1.5X	ED14X1.5VITX	2-111-N552-9	2-111-V894-9	10.77 × 2.62	8207-1/4	8207SS1/4A
3/8	ED3/8X	ED3/8VITX	2-113-N552-9	2-113-V894-9	13.94 × 2.62	8207-3/8	8207SS3/8A
1/2	ED1/2X	ED1/2VITX	5-256-N552-9	5-256-V894-9	17.96 × 2.62	8207-1/2	8207SS1/2
3/4	ED26X1.5X	ED26X1.5VITX	2-119-N552-9	2-119-V894-9	23.47 × 2.62	8207-3/4	8207SS3/4
1	ED33X2X	ED33X2VITX	2-217-N552-9	2-217-V894-9	29.74 × 3.53	8207-1	8207SS1A
1 1/4	ED42X2X	ED42X2VITX	2-222-N552-9	2-222-V894-9	37.69 × 3.53	8207-1-1/4	8207SS1 1/4
1 1/2	ED48X2X	ED48X2VITX	2-224-N552-9	2-224-V894-9	44.04 × 3.53	8207-1-1/2	8207SS1 1/2

Typical fittings using these parts: F42EDMLO/C4OMLO/V4OMLO etc.

*Must be used with correct retainer ring.

Metric male threads – ISO 9974

Thread metric	ED seal order code		O-ring order code*		O-ring ID × section mm	Retainer ring Order code Steel	Retainer ring Order code Stainless Steel
	NBR	FKM	NBR	FKM			
M 10×1.0	ED10X1/R1/8X	ED10X1R1/8VITX	6-074-N552-9	6-074-V894-9	8.00 × 1.50	M10RR	RRM10X1SS
M 12×1.5	ED12X1.5X	ED14X1.5/VITX	2-012-N552-9	2-012-V894-9	9.25 × 1.78	M12RR	RRM12X1.5SS
M 14×1.5	ED14X1.5/R1/4X	ED14X1.5/R1/4VITX	2-013-N552-9	2-013-V894-9	10.82 × 1.78	M14RR	RRM14X1.5SS
M 16×1.5	ED16X1.5X	ED16X1.5/VITX	3-907-N552-9	3-907-V894-9	13.46 × 2.08	M16RR	RRM16X1.5SS
M 18×1.5	ED18X1.5X	ED18X1.5/VITX	2-114-N552-9	2-114-V894-9	15.54 × 2.62	M18RR	RRM18X1.5SS
M 22×1.5	ED22X1.5X	ED22X1.5VITX	2-018-N552-9	2-018-V894-9	18.77 × 1.78	M22RR	RRM22X1.5SS
M 27×2.0	ED26X1.5X**	ED26X1.5VITX	2-119-N552-9	2-119-V894-9	23.47 × 2.62	M27RR	RRM27X2SS
M 33×2.0	ED33X2R1X	ED33X2/R1VITX	2-122-N552-9	2-122-V894-9	28.24 × 2.62	M33RR	RRM33X2SS
M 42×2.0	ED42X2/R1.1/4X	ED42X2R1.1/4VITX	2-128-N552-9	2-128-V894-9	37.77 × 2.62	M42RR	RRM42X2SS
M 48×2.0	ED48X2/R1.1/2X	ED48X2R1.1/2VITX	2-132-N552-9	2-132-V894-9	44.12 × 2.62	M48RR	RRM48X2SS

Typical fittings using these parts: F82EDMLO/C8OMLO/V8OMLO etc.

*Must be used with correct retainer ring.

**Same seal used for M 26×1.5 and M 27×2.0

Spare parts guide – O-Lok® retaining rings and seals

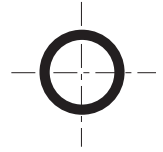

UN / UNF male threads – ISO 11926

Dash size	Thread UN/UNF	O-ring order code		O-ring ID × section mm
		NBR	FKM	
2	5/16-24	3-902-N552-9	3-902-V894-9	6.07 × 1.63
3	3/8-24	3-903-N552-9	3-903-V894-9	7.65 × 1.63
4	7/16-20	3-904-N552-9	3-904-V894-9	8.92 × 1.83
5	1/2-20	3-905-N552-9	3-905-V894-9	10.52 × 1.83
6	9/16-18	3-906-N552-9	3-906-V894-9	11.89 × 1.98
8	3/4-16	3-908-N552-9	3-908-V894-9	16.36 × 2.21
10	7/8-14	3-910-N552-9	3-910-V894-9	19.18 × 2.46
12	1 1/16-12	3-912-N552-9	3-912-V894-9	23.47 × 2.95
14	1 3/16-12	3-914-N552-9	3-914-V894-9	26.59 × 2.95
16	1 5/16-12	3-916-N552-9	3-916-V894-9	29.74 × 2.95
20	1 5/8-12	3-920-N552-9	3-920-V894-9	37.47 × 3.00
24	1 7/8-12	3-924-N552-9	3-924-V894-9	43.69 × 3.00
32	2 1/2-12	3-932-N552-9	3-932-V894-9	59.36 × 3.00

Typical fittings using these parts: F5OMLO/C5OMLO/R5OMLO etc.

Metric male threads – ISO 6149

Thread metric	O-ring order code		O-ring ID × section mm
	NBR	FKM	
M 10×1.0	6-345-N552-9	6-345-V894-9	8.20 × 1.50
M 12×1.5	6-346-N552-9	6-346-V894-9	9.40 × 2.10
M 14×1.5	6-347-N552-9	6-347-V894-9	11.40 × 2.10
M 16×1.5	6-348-N552-9	6-348-V894-9	13.40 × 2.10
M 18×1.5	6-349-N552-9	6-349-V894-9	15.40 × 2.10
M 22×1.5	6-350-N552-9	6-350-V894-9	19.40 × 2.10
M 27×2.0	6-351-N552-9	6-351-V894-9	23.70 × 2.80
M 33×2.0	6-352-N552-9	6-352-V894-9	29.70 × 2.80
M 42×2.0	6-353-N552-9	6-353-V894-9	38.70 × 2.80
M 48×2.0	6-354-N552-9	6-354-V894-9	46.70 × 2.80

Typical fittings using these parts: F87OMLO/S87OMLO etc.

Other seal compounds are available on request for alternative applications.

SBR Braze ring

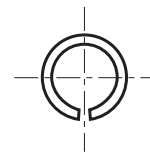

For metric tubing

Tube O.D. mm	Order code
6	SBR 6
8	SBR 8
10	SBR 10
12	SBR 12
14	SBR 14
15	SBR 15
16	SBR 16
18	SBR 18
20	SBR 20
22	SBR 22
25	SBR 25
28	SBR 28
30	SBR 30
32	SBR 32
35	SBR 35
38	SBR 38
50	SBR 50

For inch tubing

Tube O.D. in.	Order code
1/4	4SBR
3/8	6SBR
1/2	8SBR
5/8	10SBR
3/4	12SBR
1	16SBR
1 1/4	20SBR
1 1/2	24SBR
2	32SBR

Part numbers shown are part of our current manufacturing programme.

J

DMM Technology







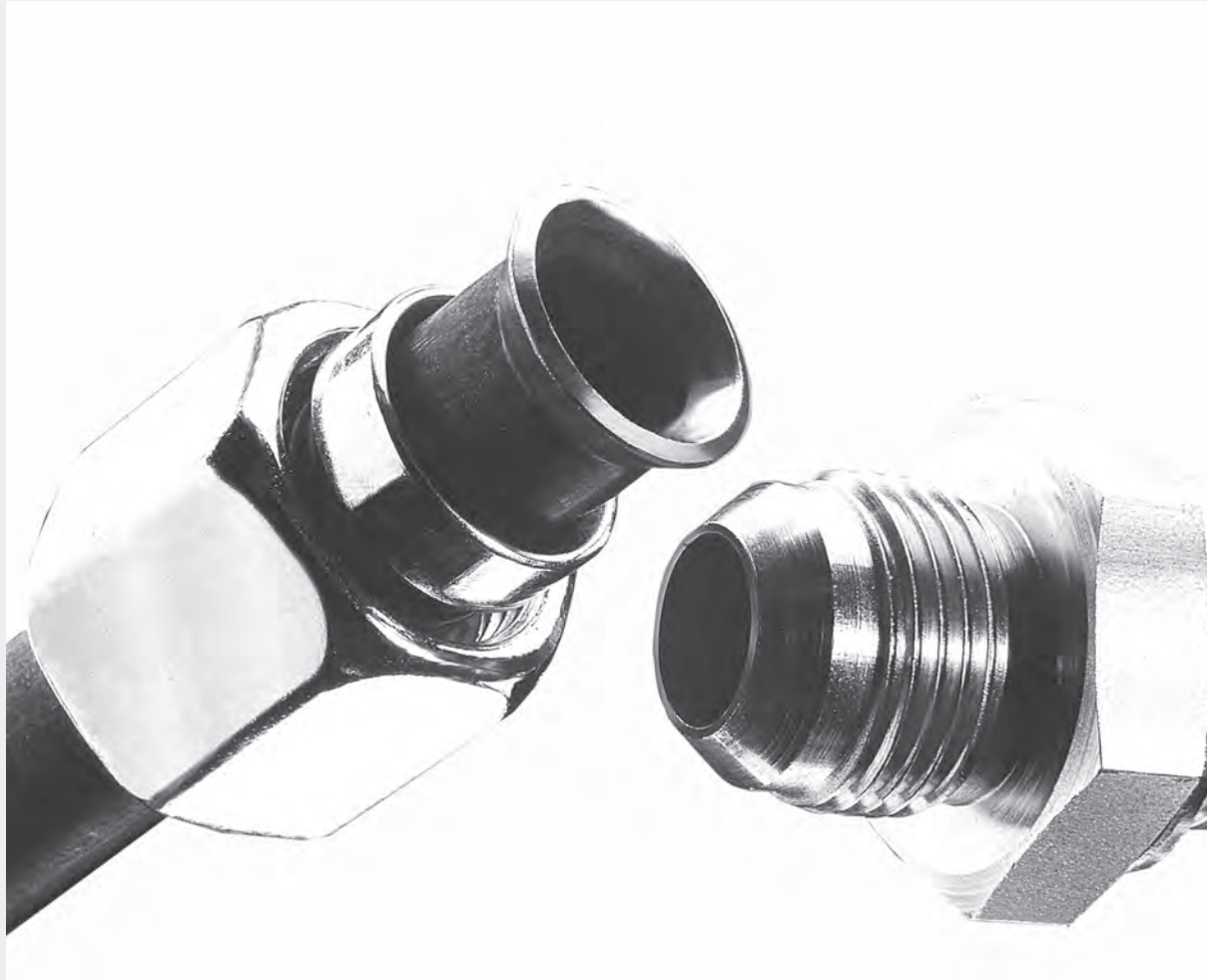



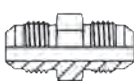
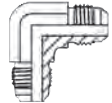
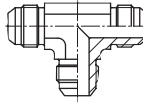

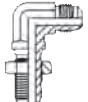
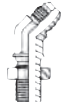

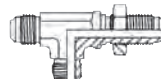

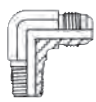

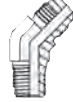
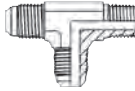
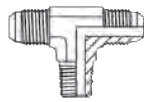

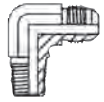

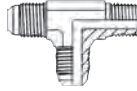
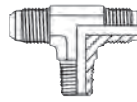
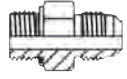
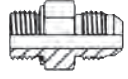
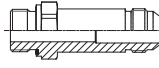
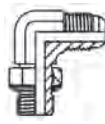

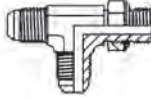
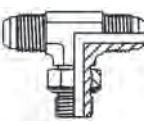
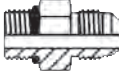
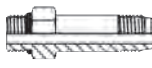
Triple-Lok[®]

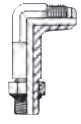

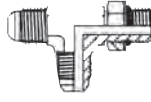
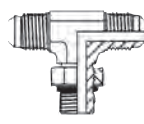
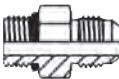

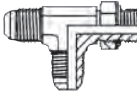
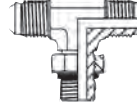
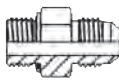
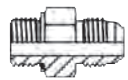

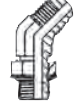
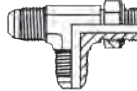
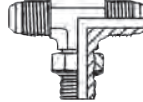
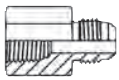
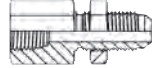
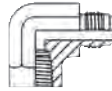
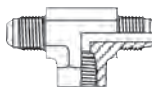
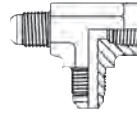
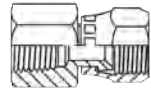



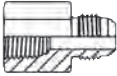
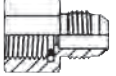
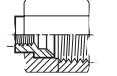
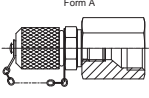
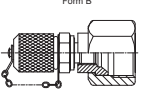
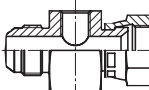

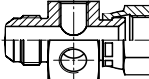
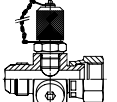
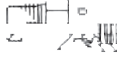

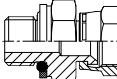
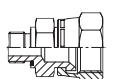

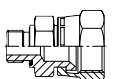

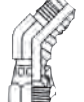
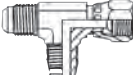
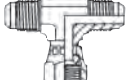

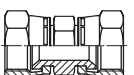
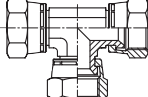
*The universal
37° flared fitting*

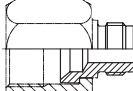
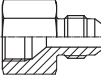

Visual index

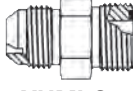
Tube to tube	 HMTX p. K9	 EMTX p. K10	 JMTX p. K11	 KTX p. K12			
Bulkhead union	 WMTX p. K13	 WEMTX p. K14	 WNTX p. K15	 WJTX p. K16	 WJJTX p. K17	 WLNM p. K91	
Tube to male NPTF	 FMTX p. K35	 CMTX p. K50	 CCTX p. K51	 CCCTX p. K52	 VMTX p. K58	 RMTX p. K70	 SMTX p. K64
Tube to male BSPT	 F3MX p. K36	 C3MX p. K53	 V3MX p. K59	 R3MX p. K71	 S3MX p. K65		
Tube to male BSPP	 F4OMX p. K32	 F42EDMX p. K30	 FF42EDMX p. K31	 C4OMX p. K48	 V4OMX p. K56	 R4OMX p. K68	 S4OMX p. K62
Tube to straight thread UNF	 F5OMX p. K27	 FF5OMX p. K29	 C5OMX p. K46	 CC5OX p. K47	 V5OMX p. K55	 R5OMX p. K67	 S5OMX p. K61
Tube to male metric ISO 6149-3	 F87OMX p. K26	 C87OMX p. K45	 V87OMX p. K54	 R87OMX p. K66	 S87OMX p. K60		
Tube to male metric DIN 3852-1	 F8OMX p. K34	 F82EDMX p. K33	 C8OMX p. K49	 V8OMX p. K57	 R8OMX p. K69	 S8OMX p. K63	
Tube to female NPTF	 GMTX p. K73	 WGMTX p. K74	 DMTX p. K75	 OTX p. K76	 MTX p. K77	 G6X p. K78	

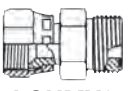
Visual index

<p>Pressure gauge connectors</p>	 G4MX p. K72  G4MXMO p. K79  TT4MX p. K80  TTP4MX p. K81  TTP4MX p. K81  R6O4MX p. K82  R6P4MX p. K83  K6OO4MX p. K84  K6PP4MX p. K85
<p>Triple-Lok® swivel nut male pipe</p>	 F6MX p. K41  F63MX p. K44
<p>Triple-Lok® swivel nut straight thread</p>	 F64OMX p. K40  F642EDMX p. K39  F65OMX p. K38  F68OMX p. K42  F682EDMX p. K41  F687OMX p. K37
<p>Tube to Triple-Lok® swivel nut</p>	 C6MX p. K18  V6MX p. K19  R6MX p. K21  S6MX p. K20  BBMTX p. K22  HMX6 p. K24  JX6 p. K25
<p>Nuts & Sleeves</p>	 BMTX p. K6  BTX p. K5  TX p. K7
<p>Tube end reducers Plug Caps</p>	 TRMTX p. K23  FNMTX p. K86  PNMTX p. K87
<p>Conversion Adapters Triple-Lok®/ O-Lok®</p>	 XHMLO p. K88  XHML6 p. K89  LOHMX6 p. K90
<p>Seals Retaining ring and Tooling</p>	 Triple-Lok® Components p. K92

K

How to order Triple-Lok® fittings

Example Order code 1 2 3 4 5 6 7
6-8 C 5 O M X S

1 Order codes for tube and port thread ends

Dash Size	Tube Size (Inch)	Tube Size (mm)	Port Thread Size (Inch) BSPP/BSPT/NPT	Port Thread Size UN / UNF
2	1/8		1/8	5/16-24
3	3/16			3/8-24
4	1/4	6	1/4	7/16-20
5				1/2-20
6	3/8	8,10	3/8	9/16-18
8	1/2	12	1/2	3/4-16
10	5/8	14,15,16	5/8	7/8-14
12	3/4	18,20	3/4	1 1/6-12
14				1 3/6-12
16	1	25	1	1 5/16-12
20	1 1/4	28,30,32	1 1/4	1 5/8-12
24	1 1/2	35,38	1 1/2	1 7/8-12
28		42		2 1/4-12
32	2	50	2	2 1/2-12

Metric port threads are shown as per example 4M12C87OMXS

3 Threads and sealing methods

Code	Description
None	NPT/NPTF Thread
3	BSPT Thread
4	BSPP Thread O-Ring & Retainer Ring
42	BSPP Thread EOLASTIC seal 'ED'
5	UN/UNF Thread (O-Ring Seal)
8	Metric Thread O-Ring & Retainer Ring
82	Metric Thread EOLASTIC seal 'ED'
87	Metric ISO 6149 Thread (O-Ring Seal)
63	Swivel Connector BSPT end
64	Swivel Connector BSPP end (O-Ring & Retainer Ring)
642	Swivel Connector BSPP end (EOLASTIC Seal 'ED')
65	Swivel Connector UN/UNF end (O-Ring seal)
68	Swivel Connector Metric end (O-Ring & Retainer Ring)
682	Swivel Connector Metric end (EOLASTIC Seal 'ED')
687	Swivel Connector Metric ISO 6149 end

2 Codes for fitting styles/shapes

Code	Description
AE6	Straight Thread Swivel
B	Nut
C	Male Stud elbow
CC	Long Male Stud elbow
CCC	Extra Long Male Stud elbow
C6	Swivel Nut Elbow
D	Female Elbow
E	Union elbow
F	Male Stud connector
FF	Long Male Stud connector
F6	Male Stud Swivel
FN	Cap
G	Female Connector
G-MO	Gauge Adapter Fitting
G6	Female Connector Swivel
H	Straight union
H6	Swivel/Swivel Adapter
J	Union Tee
J6	Swivel Tee
K	Union Cross
LOHX6	Triple-Lok® Swivel/O-Lok® Adapter
M	Female Run Tee
O	Female Branch Tee
PN	Plug
R	Male Stud Run Tee
R6	Swivel Run Tee
S	Male Stud Branch Tee
S6	Swivel Branch Tee
T	Sleeve
TR	Tube End Reducer
TT	Test Point Adapter
V	45° male stud elbow
V6	Swivel Nut 45° Elbow
W	Bulkhead Union
WE	Bulkhead Union Elbow
WG	Female Bulkhead connector
WJJ	Bulkhead Run Tee
WJT	Bulkhead Branch Tee
WLN	Bulkhead Locknut
WN	Bulkhead 45° union elbow
XHL	Triple Lok® / O-Lok® Adaptor
XHL6	Triple Lok® / O-Lok® Swivel Adaptor

4 Stud connector seal

Code	Description
O	O-Ring Seal (Assembled on fitting)
ED	Captive EOLASTIC Seal (Assembled on fitting)
No Code	No Seal (O-Ring not assembled on fitting)

5 Hexagon/ Across flats style

Code	Description
M	Metric Hexagon Dimension
No Code	Inch Hexagon Dimension

6 Fitting type

Code	Description
X	Parker Triple-Lok®

7 Fitting material

Code	Description
S	Steel
SS	Stainless Steel
B	Brass

BTX Nut

Triple-Lok® 37° Flare end nut
SAE 070110 MS51531

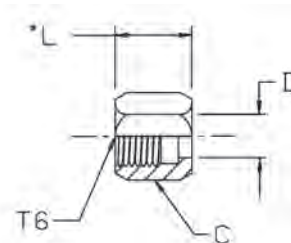

Tube O.D. mm	Tube O.D. in.	Thread UN/UNF-2B T6	C in.	D mm	L mm	Weight (steel) g/1 piece	Triple-Lok®	Triple-Lok®	Triple-Lok®
							Steel	Stainless Steel	Brass
6	1/8	5/16-24	3/8	4.5	14.0	6	2 BTX-S	2 BTX-SS	2 BTX-B
	3/16	3/8-24	7/16	6.0	15.5	8	3 BTX-S	3 BTX-SS	3 BTX-B
	1/4	7/16-20	9/16	8.0	16.0	11	4 BTX-S	4 BTX-SS	4 BTX-B
	5/16	1/2-20	5/8	9.5	17.0	14	5 BTX-S	5 BTX-SS	5 BTX-B
	3/8	9/16-18	11/16	11.0	18.5	18	6 BTX-S	6 BTX-SS	6 BTX-B
14, 15, 16	1/2	3/4-16	7/8	14.5	21.5	29	8 BTX-S	8 BTX-SS	8 BTX-B
	5/8	7/8-14	1	18.0	25.0	54	10 BTX-S	10 BTX-SS	10 BTX-B
	3/4	1 1/16-12	1 1/4	21.0	26.0	73	12 BTX-S*	12 BTX-SS*	12 BTX-B*
	7/8	1 3/16-12	1 3/8	24.0	27.5	100	14 BTX-S	14 BTX-SS	14 BTX-B
	1	1 5/16-12	1 1/2	27.5	28.5	104	16 BTX-S	16 BTX-SS	16 BTX-B
28, 30, 32 35, 38	1 1/4	1 5/8-12	2	34.0	31.0	240	20 BTX-S	20 BTX-SS	20 BTX-B
	1 1/2	1 7/8-12	2 1/4	41.0	36.0	325	24 BTX-S	24 BTX-SS	24 BTX-B
	2	2 1/2-12	2 7/8	55.0	44.5	549	32 BTX-S	32 BTX-SS	32 BTX-B

Order codes shown are part of our current manufacturing programme.

Do not create drawings from these dimensions, they are subject to change and ISO manufacturing allowances.

***Size 12 BTX-S cannot be used with the metric tube sleeve TXS20 or 20 mm tubes.
This applies to steel, stainless steel and brass.**

K

BMTX Nut

Triple-Lok® 37° Flare end nut
SAE 070110

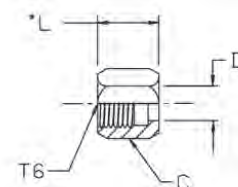

Tube O.D.		Thread UN/UNF-2B T6	C mm	D mm	L mm	Weight (steel) g/1 piece	Triple-Lok® Steel	Triple-Lok® Stainless Steel
mm	in.							
6	1/4	7/16-20	14	8.0	15.5	11	4BMTXS	4BMTXSS
8	5/16	1/2-20	17	10.0	17.0	14	5BMTXS	5BMTXSS
10	3/8	9/16-18	19	11.0	18.0	18	6BMTXS	6BMTXSS
12	1/2	3/4-16	22	14.5	21.0	29	8BMTXS	8BMTXSS
14, 15, 16	5/8	7/8-14	27	18.0	24.5	42	10BMTXS	10BMTXSS
18, 20	3/4	1 1/16-12	32	22.0	26.0	73	12BMTXS	12BMTXSS
25	1	1 5/16-12	41	28.0	28.0	104	16BMTXS	16BMTXSS
28, 30, 32	1 1/4	1 5/8-12	50	34.0	33.0	240	20BMTXS	20BMTXSS
35, 38	1 1/2	1 7/8-12	60	41.0	38.0	325	24BMTXS	24BMTXSS
42		2 1/4-12	65	48.0	40.0	437	28BMTXS	28BMTXSS

Order codes shown are part of our current manufacturing programme.

Do not create drawings from these dimensions, they are subject to change and ISO manufacturing allowances.

TX Sleeve

Triple-Lok® 37° Flare tube end sleeve for metric tubes
SAE 070105

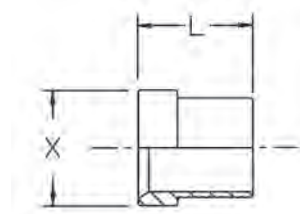

Tube O.D. mm	L mm	X mm	Weight (steel) g/1 piece	Triple-Lok® Steel	Triple-Lok® Stainless Steel	Triple-Lok® Brass
6	10.0	9.5	2	TXS6	TXSS6	TXB6
8	11.0	11.0	2	TXS8	TXSS8	TXB8
10	12.5	12.5	2	TXS10	TXSS10	TXB10
12	14.0	17.0	7	TXS12	TXSS12	TXB12
14	17.0	20.0	13	TXS14	TXSS14	TXB14
15	17.0	20.0	10	TXS15	TXSS15	TXB15
16	17.0	20.0	7	TXS16	TXSS16	TXB16
18	17.5	24.5	16	TXS18	TXSS18	TXB18
20	17.5	24.5	12	TXS20	TXSS20	TXB20
22	19.0	28.0	25	TXS22	TXSS22	TXB22
25	20.0	31.0	21	TXS25	TXSS25	TXB25
28	23.0	39.0	40	TXS28	TXSS28	TXB28
30	23.0	39.0	45	TXS30	TXSS30	TXB30
32	23.0	39.0	30	TXS32	TXSS32	TXB32
35	28.5	45.0	60	TXS35	TXSS35	TXB35
38	28.5	45.0	51	TXS38	TXSS38	TXB38
42	29.0	55.0	149	TXS42	TXSS42	TXB42

Order codes shown are part of our current manufacturing programme.

Do not create drawings from these dimensions, they are subject to change and ISO manufacturing allowances.

K

TX Sleeve

Triple-Lok® 37° Flare tube sleeve
SAE 070105 MS51533

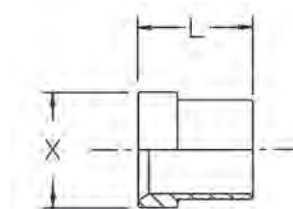

Tube O.D. in.	L mm	X mm	Weight (steel) g/1 piece	Triple-Lok® Steel	Triple-Lok® Stainless Steel	Triple-Lok® Brass
1/8	8.5	7.0	2	2 TX-S	2 TX-SS	2 TX-B
3/16	8.5	8.0	2	3 TX-S	3 TX-SS	3 TX-B
1/4	10.5	10.0	2	4 TX-S	4 TX-SS	4 TX-B
5/16	11.0	11.5	2	5 TX-S	5 TX-SS	5 TX-B
3/8	12.5	13.0	3	6 TX-S	6 TX-SS	6 TX-B
1/2	14.0	17.0	6	8 TX-S	8 TX-SS	8 TX-B
5/8	17.0	20.0	8	10 TX-S	10 TX-SS	10 TX-B
3/4	17.0	24.5	13	12 TX-S	12 TX-SS	12 TX-B
7/8	19.0	28.0	18	14 TX-S	14 TX-SS	14 TX-B
1	20.0	31.0	23	16 TX-S	16 TX-SS	16 TX-B
1 1/4	23.0	39.0	30	20 TX-S	20 TX-SS	20 TX-B
1 1/2	28.0	45.0	51	24 TX-S	24 TX-SS	24 TX-B
2	30.0	61.0	156	32 TX-S	32 TX-SS	32 TX-B

Order codes shown are part of our current manufacturing programme.

Do not create drawings from these dimensions, they are subject to change and ISO manufacturing allowances.

HMTX Union

Triple-Lok® 37° Flare ends
SAE 070101 MS51501

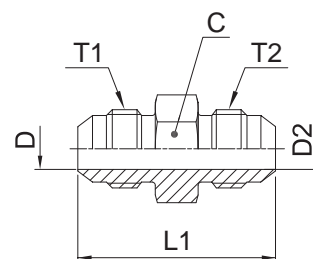

Tube 1 O.D.		Tube 2 O.D.		Thread UN/UNF-2A T1	Thread UN/UNF-2A T2	C	D	D2	L1	Weight (steel) g/1 piece	Triple-Lok® Steel	Triple-Lok® Stainless Steel	Triple-Lok® Brass	PN (bar)		
mm	in.	mm	in.			mm	mm	mm	mm					S	SS	
6	1/8	6	1/8	5/16-24	5/16-24	11.0	1.5	1.5	30.0	9	2 HTX-S			500	—	
	3/16		3/16	3/8-24	3/8-24	11.0	3.0	3.0	31.0	10	3 HTX-S			500	—	
	1/4		1/4	7/16-20	7/16-20	14.0	4.5	4.5	35.0	16	4HMTXS	4HMTXSS	4HMTXB	500	350	
	1/4		1/8	7/16-20	5/16-24	12.5	4.4	1.6	32.0	12	4-2 HTX-S	4-2HMTXSS	4-2HMTXB	500	350	
6	1/4	6	3/16	7/16-20	3/8-24	12.5	4.4	3.0	33.0	14	4-3 HTX-S	4-3HMTXSS	4-3HMTXB	500	350	
8	5/16		8	5/16	1/2-20	14.0	6.0	6.0	35.0	18	5HMTXS	5HMTXSS	5HMTXB	420	350	
8	5/16		6	1/4	1/2-20	7/16-20	14.0	6.0	4.5	35.0	18	5-4HMTXS	5-4HMTXSS	5-4HMTXB	420	350
10	3/8		10	3/8	9/16-18	9/16-18	17.0	7.5	7.5	36.0	25	6HMTXS	6HMTXSS	6HMTXB	420	350
10	3/8	6	1/4	9/16-18	7/16-20	17.0	7.5	4.5	35.5	22	6-4HMTXS	6-4HMTXSS	6-4HMTXB	420	350	
10	3/8		8	5/16	9/16-18	1/2-20	17.0	7.5	6.0	36.0	25	6-5 HTX-S	6-5HMTXSS	6-5HMTXB	420	350
12	1/2		12	1/2	3/4-16	3/4-16	19.0	9.9	9.9	41.0	52	8HMTXS	8HMTXSS	8HMTXB	420	350
12	1/2		6	1/4	3/4-16	7/16-20	20.6	9.9	4.5	38.5	45	8-4 HTX-S	8-4HMTXSS	8-4HMTXB	420	350
12	1/2	14, 15,16	10	3/8	3/4-16	9/16-18	20.6	9.9	7.5	38.5	45	8-6 HTX-S	8-6HMTXSS	8-6HMTXB	420	350
14, 15,16	5/8		14, 15,16	5/8	7/8-14	7/8-14	24.0	12.0	12.0	48.0	80	10HMTXS	10HMTXSS	10HMTXB	350	350
14, 15,16	5/8		10	3/8	7/8-14	9/16-18	24.0	12.3	7.5	43.0	60	10-6HMTXS	10-6HMTXSS	10-6HMTXB	350	350
14, 15,16	5/8		12	1/2	7/8-14	3/4-16	23.8	12.3	9.9	45.0	68	10-8 HTX-S	10-8HMTXSS	10-8HMTXB	350	350
18, 20	3/4	18, 20	3/4	1 1/16-12	1 1/16-12	27.0	15.5	15.5	55.0	125	12HMTXS	12HMTXSS	12HMTXB	350	350	
18, 20	3/4		12	1/2	1 1/16-12	3/4-16	28.5	15.5	9.9	49.5	101	12-8 HTX-S	12-8HMTXSS	12-8HMTXB	350	350
20	3/4		14, 15,16	5/8	1 1/16-12	7/8-14	27.0	15.5	12.3	52.0	113	12-10HMTXS	12-10HMTXSS	12-10HMTXB	350	350
22	7/8		22	7/8	1 3/16-12	1 3/16-12	32.0	18.0	18.0	56.0	156	14 HTX-S	14HMTXSS	14HMTXB	280	280
25	1	28, 30, 32	25	1	1 5/16-12	1 5/16-12	36.0	21.5	21.5	57.0	131	16HMTXS	16HMTXSS	16HMTXB	280	280
25	1		20	3/4	1 5/16-12	1 1/16-12	36.0	21.5	15.5	56.0	169	16-12HMTXS	16-12HMTXSS	16-12HMTXB	280	280
28, 30, 32	1 1/4		28, 30, 32	1 1/4	1 5/8-12	1 5/8-12	46.0	27.5	27.5	62.0	271	20HMTXS	20HMTXSS	20HMTXB	280	210
28, 30, 32	1 1/4		18, 20	3/4	1 5/8-12	1 1/16-12	46.0	27.5	15.5	59.5	302	20-12HMTXS	20-12HMTXSS	20-12HMTXB	280	210
28, 30, 32	1 1/4	35, 38	25	1	1 5/8-12	1 5/16-12	46.0	27.5	21.5	60.5	313	20-16HMTXS	20-16HMTXSS	20-16HMTXB	280	210
35, 38	1 1/2		35, 38	1 1/2	1 7/8-12	1 7/8-12	50.0	33.0	33.0	70.0	382	24HMTXS	24HMTXSS	24HMTXB	210	210
42	2		42	2	2 1/4-12	2 1/4-12	60.0	39.0	39.0	71.5	469	28HMTXS	28HMTXSS	28HMTXB	140	150
42			2		2 1/2-12	2 1/2-12	67.0	45.0	45.0	86.5	785	32 HTX-S	32HMTXSS	32HMTXB	140	150

Order codes shown are part of our current manufacturing programme.

Imperial and metric parts may vary in hexagon dimensions.

$$\frac{\text{PN (bar)}}{10} = \text{PN (MPa)}$$

Pressure ratings – PN shown, apply to Steel and Stainless Steel versions of the product.

For Brass parts reduce pressures by 35%.

Do not create drawings from these dimensions, they are subject to change and ISO manufacturing allowances.

EMTX Union elbow

Triple-Lok® 37° Flare ends
SAE 070201 MS51505

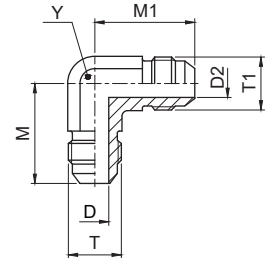

Tube O.D.		Thread UN/UNF-2A T	Thread UN/UNF-2A T1	D mm	D2 mm	M mm	M1 mm	Y mm	Weight (steel) g/1 piece	Triple-Lok® Steel	Triple-Lok® Stainless Steel	Triple-Lok® Brass	PN (bar)	
mm	in.												S	SS
6	1/8	5/16-24	5/16-24	1.6	1.6	20.0	20.0	11	18	2 ETX-S			500	—
	3/16	3/8-24	3/8-24	3.0	3.0	21.0	21.0	11	20	3 ETX-S			500	—
	1/4	7/16-20	7/16-20	4.4	4.4	22.5	22.5	11	25	4EMTXS	4EMTXSS	4 ETX-B	500	350
	5/16	1/2-20	1/2-20	6.0	6.0	24.0	24.0	13	32	5EMTXS	5EMTXSS	5 ETX-B	420	350
8	3/8	9/16-18	9/16-18	7.5	7.5	27.0	27.0	14	44	6EMTXS	6EMTXSS	6 ETX-B	420	350
10	3/8	9/16-18	7/16-20	7.5	4.4	27.0	27.0	14	40	6-4 ETX-S	6-4EMTXSS	6-4 ETX-B	420	350
12	1/2	3/4-16	3/4-16	9.9	9.9	32.0	32.0	19	88	8EMTXS	8EMTXSS	8 ETX-B	420	350
12	1/2	3/4-16	9/16-18	9.9	7.5	32.0	29.0	19	75	8-6 ETX-S	8-6EMTXSS		420	—
14, 15, 16	5/8	7/8-14	7/8-14	12.3	12.3	37.0	37.0	22	139	10EMTXS	10EMTXSS	10 ETX-B	350	350
14, 15, 16	5/8	7/8-14	3/4-16	12.3	9.9	37.0	34.0	22	120	10-8 ETX-S	10-8EMTXSS	10-8 ETX-B	350	350
18, 20	3/4	1 1/16-12	1 1/16-12	15.5	15.5	42.0	42.0	27	258	12EMTXS	12EMTXSS	12 ETX-B	350	350
18, 20	3/4	1 1/16-12	3/4-16	15.5	9.9	42.0	36.0	27	220	12-8 ETX-S	12-8EMTXSS		350	—
18, 20	3/4	1 1/16-12	7/8-14	15.5	12.3	42.0	39.0	27	240	12-10 ETX-S	12-10EMTXSS		350	—
22	7/8	1 3/16-12	1 3/16-12	18.3	18.3	45.5	45.5	30	273	14 ETX-S	14EMTXSS		280	—
22, 25	1	1 5/16-12	1 5/16-12	21.5	21.5	46.0	46.0	33	333	16EMTXS	16EMTXSS	16 ETX-B	280	280
22, 25	1	1 5/16-12	1 1/16-12	21.5	15.5	46.0	45.0	33	310	16-12 ETX-S	16-12EMTXSS	16-12 ETX-B	280	280
28, 30, 32	1 1/4	1 5/8-12	1 5/8-12	27.5	27.5	52.0	52.0	41	586	20EMTXS	20EMTXSS	20 ETX-B	280	210
35, 38	1 1/2	1 7/8-12	1 7/8-12	33.0	33.0	59.0	59.0	48	778	24EMTXS	24EMTXSS	24 ETX-B	210	140
42	1 3/4	2 1/4-12	2 1/4-12	39.0	39.0	74.0	74.0	63	1100	28 ETX-S			140	—
	2	2 1/2-12	2 1/2-12	45.0	45.0	78.0	78.0	64	1680	32 ETX-S			140	—

Order codes shown are part of our current manufacturing programme.

Imperial and metric parts may vary in hexagon dimensions.

$$\frac{\text{PN (bar)}}{10} = \text{PN (MPa)}$$

Pressure ratings – PN shown, apply to Steel and Stainless Steel versions of the product.

For Brass parts reduce pressures by 35%.

Do not create drawings from these dimensions, they are subject to change and ISO manufacturing allowances.

JMTX Union tee

Triple-Lok® 37° Flare end (three ends)
SAE 070401 MS51510

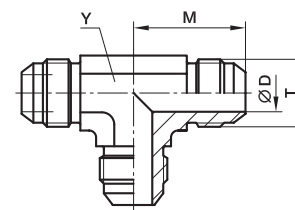

Tube O.D. mm	Tube O.D. in.	Thread UN/UNF-2A T	D mm	M mm	Y mm	Weight (steel) g/1 piece	Triple-Lok® Steel	Triple-Lok® Stainless Steel	Triple-Lok® Brass	PN (bar)	
										S	SS
6	1/8	5/16-24	1.6	19.5	8.0	25	2 JTX-S			500	—
	3/16	3/8-24	3.0	21.0	11.0	30	3 JTX-S			500	—
	1/4	7/16-20	4.4	22.5	11.0	33	4JMTXS	4JMTXSS	4 JTX-B	500	350
	5/16	1/2-20	6.0	24.0	13.0	42	5JMTXS	5JMTXSS	5 JTX-B	420	350
8	3/8	9/16-18	7.5	27.0	14.0	53	6JMTXS	6JMTXSS	6 JTX-B	420	350
	1/2	3/4-16	9.9	32.0	19.0	118	8JMTXS	8JMTXSS	8 JTX-B	420	350
14, 15, 16	5/8	7/8-14	12.3	37.0	22.0	182	10JMTXS	10JMTXSS	10 JTX-B	350	350
	3/4	1 1/16-12	15.5	42.0	27.0	291	12JMTXS	12JMTXSS	12 JTX-B	350	350
22	7/8	1 3/16-12	18.0	45.8	33.0	403	14 JTX-S	14JMTXSS	14 JTX-B	280	245
	1	1 5/16-12	21.5	46.0	33.0	415	16JMTXS	16JMTXSS	16 JTX-B	280	280
28, 30, 32	1 1/4	1 5/8-12	27.5	52.0	41.0	706	20JMTXS	20JMTXSS	20 JTX-B	280	210
	1 1/2	1 7/8-12	33.0	59.0	48.0	990	24 JTX-S	24JMTXSS	24 JTX-B	210	140
35, 38	1 3/4	2 1/4-12	39.0	74.5	63.0	2270	28 JTX-S			140	—
	2	2 1/2-12	45.0	78.0	63.5	2450	32 JTX-S			140	—

Order codes shown are part of our current manufacturing programme.

Imperial and metric parts may vary in hexagon dimensions.

$$\frac{\text{PN (bar)}}{10} = \text{PN (MPa)}$$

Pressure ratings – PN shown, apply to Steel and Stainless Steel versions of the product.

For Brass parts reduce pressures by 35%.

Union tee reducing up on request.

Do not create drawings from these dimensions, they are subject to change and ISO manufacturing allowances.

KTX Union cross

Triple-Lok® 37° Flare end (four ends)
SAE 070501 MS51517

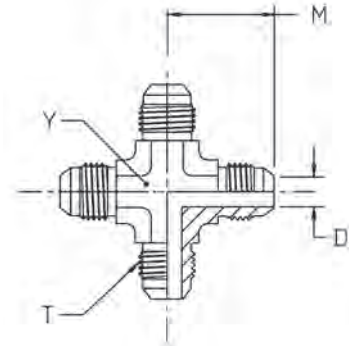

Tube O.D.		Thread UN/UNF-2A T	D mm	M mm	Y mm	Weight (steel) g/1 piece	Triple-Lok® Steel	Triple-Lok® Stainless Steel	Triple-Lok® Brass	PN (bar)	
mm	in.									S	SS
6	1/4	7/16-20	4.4	22.5	11	41	4 KTX-S	4 KTX-SS	4 KTX-B	500	350
8	5/16	1/2-20	6.0	24.0	14	50	5 KTX-S	5 KTX-SS	5 KTX-B	420	350
10	3/8	9/16-18	7.5	27.0	14	68	6 KTX-S	6 KTX-SS	6 KTX-B	420	350
12	1/2	3/4-16	9.9	31.8	19	144	8 KTX-S	8 KTX-SS	8 KTX-B	420	350
14, 15, 16	5/8	7/8-14	12.0	37.0	22	220	10 KTX-S	10 KTX-SS	10 KTX-B	350	350
18, 20	3/4	1 1/16-12	15.5	42.0	27	345	12 KTX-S	12 KTX-SS	12 KTX-B	350	350
25	1	1 5/16-12	21.5	46.0	33	588	16 KTX-S	16 KTX-SS	16 KTX-B	280	280

Order codes shown are part of our current manufacturing programme.

Imperial and metric parts may vary in hexagon dimensions.

$$\frac{\text{PN (bar)}}{10} = \text{PN (MPa)}$$

Pressure ratings – PN shown, apply to Steel and Stainless Steel versions of the product.

For Brass parts reduce pressures by 35%.

Do not create drawings from these dimensions, they are subject to change and ISO manufacturing allowances.

WMTX Bulkhead union

Triple-Lok® 37° Flare ends
SAE 070601 MS51520

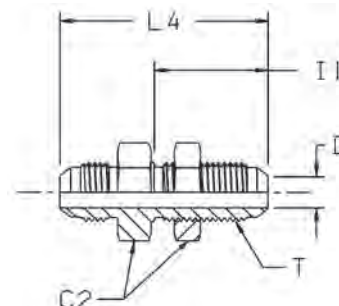

Tube O.D.		Thread UN/UNF-2A T	C2 mm	D mm	I1 mm	L4 mm	Weight (steel) g/1 piece	Triple-Lok® Steel	Triple-Lok® Stainless Steel	Triple-Lok® Brass	PN (bar)	
mm	in.										S	SS
6	1/4	7/16-20	17	4.4	30.5	52.5	41	4WMTXWLNMS	4WMTXWLNMS	4WMTXWLNMB	500	350
8	5/16	1/2-20	19	6.0	30.5	52.5	49	5WMTXWLNMS	5WMTXWLNMS	5WMTXWLNMB	420	350
10	3/8	9/16-18	22	7.5	32.5	55.5	64	6WMTXWLNMS	6WMTXWLNMS	6WMTXWLNMB	420	350
12	1/2	3/4-16	24	9.9	36.5	62.0	111	8WMTXWLNMS	8WMTXWLNMS	8WMTXWLNMB	420	350
14, 15, 16	5/8	7/8-14	30	12.3	40.0	70.0	157	10WMTXWLNMS	10WMTXWLNMS	10WMTXWLNMB	350	350
18, 20	3/4	1 1/16-12	36	15.5	44.5	78.5	254	12WMTXWLNMS	12WMTXWLNMS	12WMTXWLNMB	350	350
22	7/8	1 3/16-12	38	18.3	44.5	79.3	296	14 WTX-WLN-S	14WMTXWLNMS	14WMTXWLNMB	280	280
25	1	1 5/16-12	41	21.5	44.5	80.0	337	16WMTXWLNMS	16WMTXWLNMS	16WMTXWLNMB	280	280
28, 30, 32	1 1/4	1 5/8-12	50	27.5	46.0	84.0	462	20WMTXWLNMS	20WMTXWLNMS	20WMTXWLNMB	280	210
35, 38	1 1/2	1 7/8-12	55	33.0	46.0	89.5	695	24WMTXWLNMS	24WMTXWLNMS	24WMTXWLNMB	210	140

Order codes shown are part of our current manufacturing programme.

Imperial and metric parts may vary in hexagon dimensions.

For the version without the locknut remove "WLN" (e. g. 16WMTX)

$$\frac{\text{PN (bar)}}{10} = \text{PN (MPa)}$$

Pressure ratings – PN shown, apply to Steel and Stainless Steel versions of the product.

For Brass parts reduce pressures by 35%.

Do not create drawings from these dimensions, they are subject to change and ISO manufacturing allowances.

Maximum bulkhead wallthickness

Size	Tube O.D.		Straight bulkhead union Max. thickness mm	Shape bulkhead union Max. thickness mm
	inch	metric		
4	1/4	6	8.4	5.3
5	5/16	8	8.4	5.3
6	3/8	10	10.7	7.1
8	1/2	12	11.2	8.4
10	5/8	14–16	10.9	8.1
12	3/4	18–20	11.2	8.6
14	7/8	22	10.4	7.9
16	1	25	9.9	7.4
20	1 1/4	28–32	10.2	7.4
24	1 1/2	35–38	7.1	—
32	2	—	7.1	—

WEMTX Bulkhead union elbow

Triple-Lok® 37° Flare ends
SAE 070701 MS51507

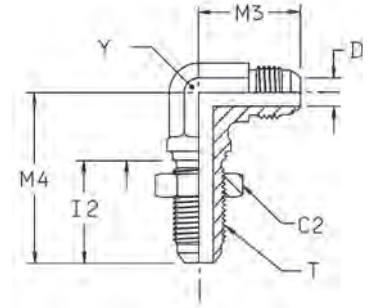

Tube O.D.		Thread UN/UNF-2A T	C2 mm	D mm	I2 mm	M3 mm	M4 mm	Y mm	Weight (steel) g/1 piece	Triple-Lok® Steel	Triple-Lok® Stainless Steel	Triple-Lok® Brass	PN (bar)	
mm	in.												S	SS
6	1/4	7/16-20	17.5	4.4	23	25.0	40	11	44	4 WETX-WLN-S	4 WETX-WLN-SS	4 WETX-WLN-B	500	350
8	5/16	1/2-20	19.0	6.0	26	27.0	44	14	59	5 WEMTXWLNMS	5 WETX-WLN-SS	5 WETX-WLN-B	420	350
10	3/8	9/16-18	22.0	7.5	28	28.0	46	14	72	6WEMTXWLNMS	6 WETX-WLN-SS	6 WETX-WLN-B	420	350
12	1/2	3/4-16	24.0	9.9	32	34.5	54	19	145	8WEMTXWLNMS	8 WETX-WLN-SS	8 WETX-WLN-B	420	350
14, 15, 16	5/8	7/8-14	30.0	12.0	35	40.0	61	22	212	10WEMTXWLNMS	10 WETX-WLN-SS	10 WETX-WLN-B	350	350
18, 20	3/4	1 1/16-12	36.0	15.5	40	45.0	68	27	345	12WEMTXWLNMS	12 WETX-WLN-SS	12 WETX-WLN-B	350	350
22	7/8	1 3/16-12	38.0	18.0	40	49.0	71	33	370	14 WETX-WLN-S	14 WETX-WLN-SS		280	280
25	1	1 5/16-12	41.0	21.5	40	49.0	71	33	474	16 WETX-WLN-S	16 WETX-WLN-SS		280	280
28, 30, 32	1 1/4	1 5/8-12	47.6	27.4	41	55.0	79	41	753	20 WETX-WLN-S	20 WETX-WLN-SS		280	280

Order codes shown are part of our current manufacturing programme.

Imperial and metric parts may vary in hexagon dimensions.

For the version without the locknut remove "WLNMS" (e. g. 16WETX)

$$\frac{PN \text{ (bar)}}{10} = PN \text{ (MPa)}$$

Pressure ratings – PN shown, apply to Steel and Stainless Steel versions of the product.

For Brass parts reduce pressures by 35%.

Do not create drawings from these dimensions, they are subject to change and ISO manufacturing allowances.

Maximum bulkhead wallthickness

Size	Tube O.D.		Straight bulkhead union Max. thickness mm	Shape bulkhead union Max. thickness mm
	inch	metric		
4	1/4	6	8.4	5.3
5	5/16	8	8.4	5.3
6	3/8	10	10.7	7.1
8	1/2	12	11.2	8.4
10	5/8	14-16	10.9	8.1
12	3/4	18-20	11.2	8.6
14	7/8		10.4	7.9
16	1	22-25	9.9	7.4
20	1 1/4	28-32	10.2	7.4
24	1 1/2	35-38	7.1	—
32	2		7.1	—

WNTX 45° Bulkhead union elbow

Triple-Lok® 37° Flare ends

SAE 070801 MS51509

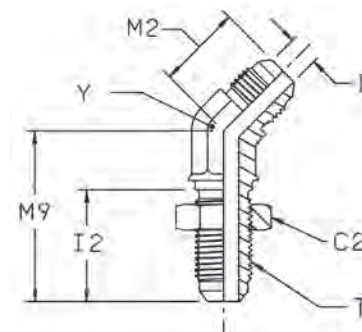

Tube O.D.		Thread UN/UNF-2A T	C2 mm	D mm	I2 mm	M2 mm	M9 mm	Y mm	Weight (steel) g/1 piece	Triple-Lok® Steel	Triple-Lok® Stainless Steel	PN (bar)	
mm	in.											S	SS
6	1/4	7/16-20	17.5	4.4	26	18	39	11	32	4 WNTX-WLN-S	4 WNTX-WLN-SS	500	350
8	5/16	1/2-20	19.0	6.0	26	20	42	14	41	5 WNTX-WLN-S		420	—
10	3/8	9/16-18	20.5	7.5	28	21	42	14	48	6 WNTX-WLN-S	6 WNTX-WLN-SS	420	350
12	1/2	3/4-16	25.5	9.9	32	33	62	19	105	8 WNTX-WLN-S	8 WNTX-WLN-SS	420	350
14, 15, 16	5/8	7/8-14	28.5	12.3	35	28	55	22	152	10 WNTX-WLN-S	10 WNTX-WLN-SS	350	350
18, 20	3/4	1 1/16-12	35.0	15.5	40	33	62	27	245	12 WNTX-WLN-S	12 WNTX-WLN-SS	350	350
22, 25	1	1 5/16-12	41.0	21.5	40	37	65	33	355	16 WNTX-WLN-S	16 WNTX-WLN-SS	280	280
28, 30, 32	1 1/4	1 5/8-12	47.6	27.4	41	40	67	41	465	20 WNTX-WLN-S		280	—

Order codes shown are part of our current manufacturing programme.

Imperial and metric parts may vary in hexagon dimensions.

For the version without the locknut remove "WLN" (e.g. 16 WNTX)

$\frac{\text{PN (bar)}}{10} = \text{PN (MPa)}$

Do not create drawings from these dimensions, they are subject to change and ISO manufacturing allowances.

K

Maximum bulkhead wallthickness

Size	Tube O.D.		Straight bulkhead union Max. thickness mm	Shape bulkhead union Max. thickness mm
	inch	metric		
4	1/4	6	8.4	5.3
5	5/16	8	8.4	5.3
6	3/8	10	10.7	7.1
8	1/2	12	11.2	8.4
10	5/8	14-16	10.9	8.1
12	3/4	18-20	11.2	8.6
14	7/8		10.4	7.9
16	1	22-25	9.9	7.4
20	1 1/4	28-32	10.2	7.4
24	1 1/2	35-38	7.1	—
32	2		7.1	—

WJTX Bulkhead branch tee

Triple-Lok® 37° Flare ends
SAE 070959 MS51515

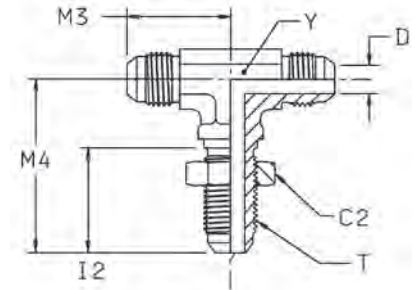

Tube O.D.		Thread UN/UNF-2A T	C2 mm	D mm	I2 mm	M3 mm	M4 mm	Y mm	Weight (steel) g/1 piece	Triple-Lok® Steel	Triple-Lok® Stainless Steel	PN (bar)	
mm	in.											S	SS
6	1/4	7/16-20	17.5	4.4	26	25	40	11.0	45	4 WJTX-WLN-S	4 WJTX-WLN-SS	500	350
10	3/8	9/16-18	20.6	7.5	28	28	46	14.0	71	6 WJTX-WLN-S	6 WJTX-WLN-SS	420	350
12	1/2	3/4-16	25.0	9.9	32	35	54	19.0	158	8 WJTX-WLN-S	8 WJTX-WLN-SS	420	350
14, 15, 16	5/8	7/8-14	28.5	12.0	35	40	61	27.0	297	10 WJTX-WLN-S	10 WJTX-WLN-SS	350	350
18, 20	3/4	1 1/16-12	35.0	15.5	40	45	68	27.0	379	12 WJTX-WLN-S	12 WJTX-WLN-SS	350	350
22, 25	1	1 5/16-12	41.3	21.4	40	49	71	33.0	420	16 WJTX-WLN-S		280	—
28, 30, 32	1 1/4	1 5/8-12	47.6	24.4	41	55	79	44.5	500	20 WJTX-WLN-S		280	—

Order codes shown are part of our current manufacturing programme.

Imperial and metric parts may vary in hexagon dimensions.

For the version without the locknut remove "WLN" (e.g. 16 WJTX)

$$\frac{PN \text{ (bar)}}{10} = PN \text{ (MPa)}$$

Do not create drawings from these dimensions, they are subject to change and ISO manufacturing allowances.

Maximum bulkhead wallthickness

Size	Tube O.D.		Straight bulkhead union Max. thickness mm	Shape bulkhead union Max. thickness mm
	inch	metric		
4	1/4	6	8.4	5.3
5	5/16	8	8.4	5.3
6	3/8	10	10.7	7.1
8	1/2	12	11.2	8.4
10	5/8	14-16	10.9	8.1
12	3/4	18-20	11.2	8.6
14	7/8		10.4	7.9
16	1	22-25	9.9	7.4
20	1 1/4	28-32	10.2	7.4
24	1 1/2	35-38	7.1	—
32	2		7.1	—

WJJTX Bulkhead run tee

Triple-Lok® 37° Flare ends
SAE 070958 MS51516

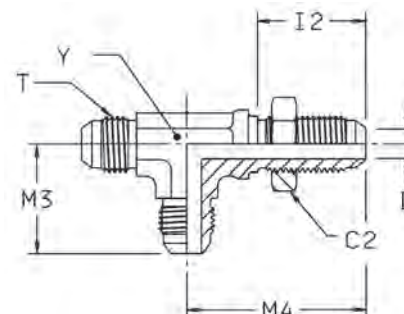

Tube O.D. mm	Tube O.D. in.	Thread UN/UNF-2A T	C2 mm	D mm	I2 mm	M3 mm	M4 mm	Y mm	Weight (steel) g/1 piece	Triple-Lok® Steel	PN (bar)
6	1/4	7/16-20	17.5	4.4	26	25	40	11.0	58	4 WJJTX-WLN-S	500
10	3/8	9/16-18	20.6	7.5	28	28	46	14.0	75	6 WJJTX-WLN-S	420
12	1/2	3/4-16	25.0	9.9	32	35	54	19.0	158	8 WJJTX-WLN-S	420
14, 15, 16	5/8	7/8-14	28.5	12.0	35	40	61	27.0	309	10 WJJTX-WLN-S	350
18, 20	3/4	1 1/16-12	35.0	15.5	40	45	68	27.0	340	12 WJJTX-WLN-S	350
22, 25	1	1 5/16-12	41.3	21.5	40	49	71	36.5	390	16 WJJTX-WLN-S	280
28, 30, 32	1 1/4	1 5/8-12	47.6	27.5	41	55	79	44.5	450	20 WJJTX-WLN-S	280

Order codes shown are part of our current manufacturing programme.

Imperial and metric parts may vary in hexagon dimensions.

For the version without the locknut remove "WLN" (e.g. 16 WJJTX)

$$\frac{\text{PN (bar)}}{10} = \text{PN (MPa)}$$

Do not create drawings from these dimensions, they are subject to change and ISO manufacturing allowances.

K

Maximum bulkhead wallthickness

Size	Tube O.D.		Straight bulkhead union Max. thickness mm	Shape bulkhead union Max. thickness mm
	inch	metric		
4	1/4	6	8.4	5.3
5	5/16	8	8.4	5.3
6	3/8	10	10.7	7.1
8	1/2	12	11.2	8.4
10	5/8	14-16	10.9	8.1
12	3/4	18-20	11.2	8.6
14	7/8		10.4	7.9
16	1	22-25	9.9	7.4
20	1 1/4	28-32	10.2	7.4
24	1 1/2	35-38	7.1	—
32	2		7.1	—

C6MX Swivel nut elbow

Triple-Lok® 37° Flare end / Triple-Lok® 37° Flare female swivel end
SAE 070221 MS51521

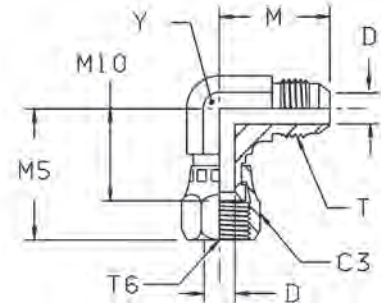

Tube O.D. mm	in.	Thread UN/UNF-2A T	Thread UN/UNF-2B T6	C3 mm	D mm	M mm	M5 mm	M10 mm	Y mm	Weight (steel) g/1 piece	Triple-Lok® Steel	Triple-Lok® Stainless Steel	PN (bar)	
													S	SS
6	3/16	3/8-24	3/8-24		3.0	21	25	18		27	3 C6X-S		500	—
	1/4	7/16-20	7/16-20	14	4.4	23	25	17	11	37	4C6MXS	4C6MXSS	500	350
	5/16	1/2-20	1/2-20	17	6.0	24	25	17	13	43	5C6MXS	5C6MXSS	420	350
	3/8	9/16-18	9/16-18	19	7.5	27	27	22	14	54	6C6MXS	6C6MXSS	350	350
	1/2	3/4-16	3/4-16	22	9.9	32	34	24	19	105	8C6MXS	8C6MXSS	350	350
14, 15, 16	5/8	7/8-14	7/8-14	27	12.0	37	40	28	22	162	10C6MXS	10C6MXSS	350	350
	3/4	1 1/16-12	1 1/16-12	32	15.5	42	42	30	27	260	12C6MXS	12C6MXSS	350	350
22	7/8	1 3/16-12	1 3/16-12	35	18.3	46	45	34	33	293	14 C6X-S		250	—
25	1	1 5/16-12	1 5/16-12	38	21.5	46	52	37	33	420	16C6MXS	16C6MXSS	250	250
28, 30, 32	1 1/4	1 5/8-12	1 5/8-12	50	27.5	52	59	43	41	679	20C6MXS	20C6MXSS	250	210
	1 1/2	1 7/8-12	1 7/8-12	57	33.0	59	67	47	48	747	24 C6X-S	24C6MXSS	170	140
35, 38	2	2 1/2-12	2 1/2-12	73	45.0	78	87	62	64	920	32 C6X-S		110	—

Order codes shown are part of our current manufacturing programme.

Imperial and metric parts may vary in hexagon dimensions.

$$\frac{\text{PN (bar)}}{10} = \text{PN (MPa)}$$

Do not create drawings from these dimensions, they are subject to change and ISO manufacturing allowances.

V6MX 45° Swivel nut elbow

Triple-Lok® 37° Flare end / Triple-Lok® 37° Flare female swivel end
SAE 070321 MS51522

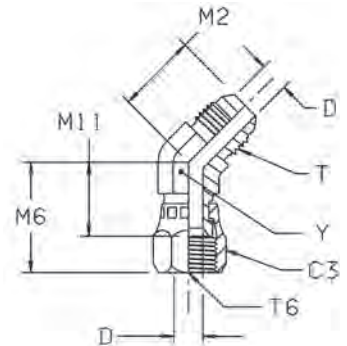

Tube O.D.		Thread UN/UNF-2A T	Thread UN/UNF-2B T6	C3 mm	D mm	M2 mm	M6 mm	M11 mm	Y mm	Weight (steel) g/1 piece	Triple-Lok® Steel	Triple-Lok® Stainless Steel	PN (bar)	
mm	in.												S	SS
6	1/4	7/16-20	7/16-20	14.3	4.4	18	24	15	11.0	30	4 V6X-S	4 V6X-SS	500	350
8	5/16	1/2-20	1/2-20	16.0	6.0	20	26	16	14.0	45	5 V6X-S	5 V6X-SS	420	350
10	3/8	9/16-18	9/16-18	19.0	7.5	21	29	19	14.0	47	6V6MXS	6 V6X-SS	350	350
12	1/2	3/4-16	3/4-16	22.0	9.9	25	33	22	19.0	89	8V6MXS	8 V6X-SS	350	350
14, 15, 16	5/8	7/8-14	7/8-14	27.0	12.3	28	37	24	22.0	131	10V6MXS	10 V6X-SS	350	350
18, 20	3/4	1 1/16-12	1 1/16-12	32.0	15.5	33	38	24	27.0	203	12V6MXS	12 V6X-SS	350	350
22	7/8	1 3/16-12	1 3/16-12	35.0	18.2	37	43	28	30.0	291	14 V6X-S		250	—
25	1	1 5/16-12	1 5/16-12	38.0	21.4	37	46	30	33.3	335	16 V6X-S	16 V6X-SS	250	250
28, 30, 32	1 1/4	1 5/8-12	1 5/8-12	50.8	27.3	40	53	36	41.0	572	20 V6X-S	20 V6X-SS	250	210
35, 38	1 1/2	1 7/8-12	1 7/8-12	57.0	33.3	45	58	39	48.0	715	24 V6X-S	24 V6X-SS	170	140
	2	2 1/2-12	2 1/2-12	73.0	45.2	56	73	50	66.0	960	32 V6X-S	32 V6X-SS	110	110

Order codes shown are part of our current manufacturing programme.

Imperial and metric parts may vary in hexagon dimensions.

$$\frac{\text{PN (bar)}}{10} = \text{PN (MPa)}$$

Do not create drawings from these dimensions, they are subject to change and ISO manufacturing allowances.

S6MX Swivel nut branch tee

Triple-Lok® 37° Flare ends / Triple-Lok® 37° Flare female swivel end
 SAE 070433 MS51524

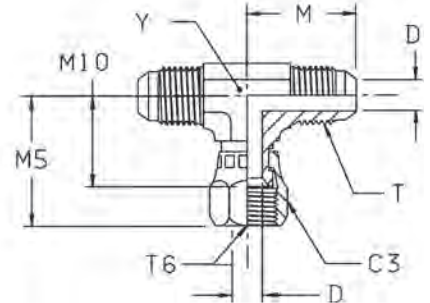

Tube O.D.		Thread UN/UNF-2A T	Thread UN/UNF-2B T6	C3 mm	D mm	M mm	M5 mm	M10 mm	Y mm	Weight (steel) g/1 piece	Triple-Lok® Steel	Triple-Lok® Stainless Steel	PN (bar)	
mm	in.												S	SS
6	1/4	7/16-20	7/16-20	14.3	4.4	23	26	17	11.0	44	4 S6X-S	4 S6X-SS	500	350
8	5/16	1/2-20	1/2-20	17.0	6.0	24	27	17	13.0	58	5S6MXS	5 S6X-SS	420	350
10	3/8	9/16-18	9/16-18	19.0	7.5	27	32	22	14.0	71	6S6MXS	6 S6X-SS	350	350
12	1/2	3/4-16	3/4-16	22.0	9.9	32	35	24	19.0	133	8S6MXS	8 S6X-SS	350	350
14, 15, 16	5/8	7/8-14	7/8-14	27.0	12.3	37	41	28	22.0	203	10S6MXS	10 S6X-SS	350	350
18, 20	3/4	1 1/16-12	1 1/16-12	32.0	15.5	42	43	30	27.0	328	12S6MXS	12 S6X-SS	350	350
25	1	1 5/16-12	1 5/16-12	38.0	21.5	46	52	36	33.0	483	16S6MXS	16 S6X-SS	250	250
28, 30, 32	1 1/4	1 5/8-12	1 5/8-12	50.8	27.3	52	60	43	41.0	708	20 S6X-S	20 S6X-SS	250	210
35, 38	1 1/2	1 7/8-12	1 7/8-12	57.0	33.3	59	68	49	47.7	1100	24 S6X-S	24 S6X-SS	170	170

Order codes shown are part of our current manufacturing programme.

Imperial and metric parts may vary in hexagon dimensions.

$$\frac{\text{PN (bar)}}{10} = \text{PN (MPa)}$$

Do not create drawings from these dimensions, they are subject to change and ISO manufacturing allowances.

R6MX Swivel nut run tee

Triple-Lok® 37° Flare ends / Triple-Lok® 37° Flare female swivel end
SAE 070432

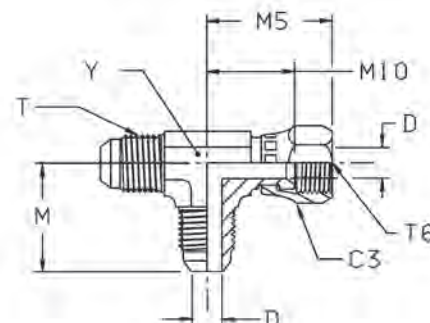

Tube O.D.		Thread UN/UNF-2A T	Thread UN/UNF-2B T6	C3 mm	D mm	M mm	M5 mm	M10 mm	Y mm	Weight (steel) g/1 piece	Triple-Lok® Steel	Triple-Lok® Stainless Steel	PN (bar)	
mm	in.												S	SS
6	1/4	7/16-20	7/16-20	14.0	4.4	23	26	17	11.0	44	4R6MXS	4 R6X-SS	500	350
8	5/16	1/2-20	1/2-20	17.0	6.0	24	26	17	13.0	56	5R6MXS	5 R6X-SS	420	350
10	3/8	9/16-18	9/16-18	19.0	7.5	27	32	22	14.0	69	6R6MXS	6 R6X-SS	350	350
12	1/2	3/4-16	3/4-16	22.0	9.9	32	35	24	19.0	136	8R6MXS	8 R6X-SS	350	350
14, 15, 16	5/8	7/8-14	7/8-14	27.0	12.3	37	41	28	22.0	207	10R6MXS	10 R6X-SS	350	350
18, 20	3/4	1 1/16-12	1 1/16-12	32.0	15.5	42	43	30	27.0	319	12R6MXS	12 R6X-SS	350	350
22	7/8	1 3/16-12	1 3/16-12	35.0	18.2	46	46	49	34.0	333	14 R6X-S	14 R6MX-SS	250	250
25	1	1 5/16-12	1 5/16-12	38.0	21.5	46	51	36	33.0	489	16R6MXS	16 R6X-SS	250	250
28, 30, 32	1 1/4	1 5/8-12	1 5/8-12	50.8	27.4	52	60	43	41.0	712	20 R6X-S	20 R6X-SS	250	210
35, 38	1 1/2	1 7/8-12	1 7/8-12	57.0	33.3	59	66	47	47.7	1100	24 R6X-S	24 R6X-SS	170	170

Order codes shown are part of our current manufacturing programme.

Imperial and metric parts may vary in hexagon dimensions.

$$\frac{\text{PN (bar)}}{10} = \text{PN (MPa)}$$

Do not create drawings from these dimensions, they are subject to change and ISO manufacturing allowances.

BBMTX Swivel nut female connector

Triple-Lok® 37° Flare fixed female end / Triple-Lok® 37° Flare female swivel end

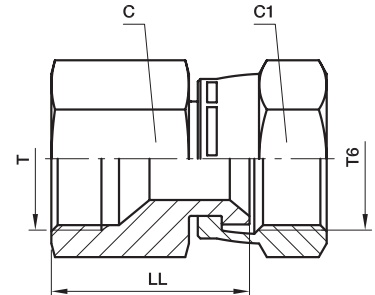

Tube O.D. mm	Tube O.D. in.	Thread UN/UNF-2A T	Thread UN/UNF-2B T6	C mm	C1 mm	LL mm	Weight (steel) g/1 piece	Triple-Lok® Steel	Triple-Lok® Stainless Steel	PN (bar)	
										S	SS
6	1/4	7/16-20	7/16-20	14	14	23.0	25	4BBMTXS	4BBMTXSS	500	350
8	5/16	1/2-20	1/2-20	17	17	25.5	32	5BBMTXS	5BBMTXSS	420	350
10	3/8	9/16-18	9/16-18	19	19	25.5	60	6BBMTXS	6BBMTXSS	350	350
12	1/2	3/4-16	3/4-16	22	22	32.0	87	8BBMTXS	8BBMTXSS	350	350
14, 15, 16	5/8	7/8-14	7/8-14	27	27	36.0	150	10BBMTXS	10BBMTXSS	350	350
18, 20	3/4	1 1/16-12	1 1/16-12	32	32	37.0	221	12BBMTXS	12BBMTXSS	350	350
25	1	1 5/16-12	1 5/16-12	41	38	42.0	348	16BBMTXS	16BBMTXSS	250	250
28, 30, 32	1 1/4	1 5/8-12	1 5/8-12	50	50	47.0	955	20BBMTXS	20BBMTXSS	250	210
35, 38	1 1/2	1 7/8-12	1 7/8-12	60	60	54.0	1031	24BBMTXS	24BBMTXSS	170	140

Order codes shown are part of our current manufacturing programme.

Imperial and metric parts may vary in hexagon dimensions.

$$\frac{\text{PN (bar)}}{10} = \text{PN (MPa)}$$

Do not create drawings from these dimensions, they are subject to change and ISO manufacturing allowances.

TRMTX Tube end reducer

Triple-Lok® 37° Flare end / Triple-Lok® 37° Flare female swivel* end
SAE 070123 MS51534

*Form A Fixed Female Style

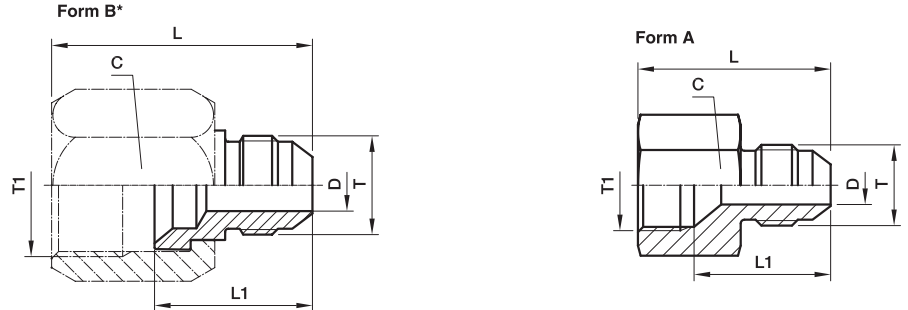

* For Form B, a BTX- or BMTX-nut is required (to be ordered separately)

Tube Metric T1 O.D.	Tube Metric T O.D.	Tube in. T1 O.D.	Tube in. T O.D.	Thread UN/UNF-2B T1	Thread UN/UNF-2A T	Typ	C mm	D mm	L mm	L1 mm	Weight (steel) g/1 piece	Triple-Lok® Steel	Triple-Lok® Stainless Steel	Triple-Lok® Brass	PN (bar)	
															S	SS
8	6	1/4	1/8	7/16-20	5/16-24	B	14.3	1.6	29.0	19.0	16	4-2 TRTX-S	4-2TRMTXSS	6-4 TRTX-B	500	350
		5/16	1/4	1/2-20	7/16-20	A	17.0	4.4	29.0	20.0	21	5-4TRMTXS	5-4TRMTXSS		420	350
		3/8	1/4	9/16-18	7/16-20	B	19.0	4.4	36.0	24.5	35	6-4TRTXS	6-4TRMTXSS		420	350
		3/8	5/16	9/16-18	1/2-20	A	19.0	6.0	30.0	21.0	29	6-5TRMTXS	6-5TRMTXSS		420	350
12	6	1/2	1/4	3/4-16	7/16-20	B	22.0	4.4	38.0	25.5	38	8-4TRTXS	8-4TRMTXSS	8-4 TRTX-B	420	350
12	8	1/2	5/16	3/4-16	1/2-20	B	22.0	6.0	38.0	25.5	35	8-5TRTXS	8-5TRMTXSS	8-6 TRTX-B	420	350
		1/2	3/8	3/4-16	9/16-18	B	22.0	7.5	38.0	25.5	32	8-6TRTXS	8-6TRMTXSS		420	350
14, 15, 16	6	5/8	1/4	7/8-14	7/16-20	B	27.0	4.4	41.0	26.0	83	10-4 TRTX-S	10-4TRMTXSS	10-6 TRTX-B	350	350
14, 15, 16	8	5/8	5/16	7/8-14	1/2-20	B	27.0	6.0	41.0	26.0	80	10-5TRTXS	10-5TRMTXSS		350	350
14, 15, 16	10	5/8	3/8	7/8-14	9/16-18	B	27.0	7.5	41.0	26.0	78	10-6 TRTX-S	10-6TRMTXSS	10-6 TRTX-B	350	350
14, 15, 16	12	5/8	1/2	7/8-14	3/4-16	A	27.0	9.9	36.5	24.5	73	10-8TRMTXS	10-8TRMTXSS	12-4 TRTX-B	350	350
18, 20	6	3/4	1/4	1 1/16-12	7/16-20	B	31.8	4.4	42.5	27.5	120	12-4 TRTX-S	12-4TRMTXSS		350	350
18, 20	8	3/4	5/16	1 1/16-12	1/2-20	B	32.0	6.0	42.5	27.5	118	12-5TRTXS	12-5TRMTXSS		350	350
18, 20	10	3/4	3/8	1 1/16-12	9/16-18	B	31.8	7.5	43.0	27.5	115	12-6 TRTX-S	12-6TRMTXSS		12-6 TRTX-B	350
18, 20	12	3/4	1/2	1 1/16-12	3/4-16	B	32.0	9.9	45.0	30.0	128	12-8TRTXS	12-8TRMTXSS	12-8 TRTX-B	350	350
18, 20	14, 15, 16	3/4	5/8	1 1/16-12	7/8-14	A	32.0	12.3	42.0	29.5	119	12-10TRMTXS	12-10TRMTXSS		350	350
22	10	7/8	3/8	1 3/16-12	9/16-18	B	35.0	7.5	45.0	29.0	102	14-6 TRTX-S	14-6TRMTXSS		350	350
22	14, 15, 16	7/8	5/8	1 3/16-12	7/8-14	B	35.0	12.3	50.0	34.0	120	14-10 TRTX-S	14-10TRMTXSS		350	350
22	18, 20	7/8	3/4	1 3/16-12	1 1/16-12	A	35.0	15.5	46.5	33.0	166	14-12 TRTX-S	14-12TRMTXSS		350	350
25	6	1	1/4	1 5/16-12	7/16-20	B	38.0	4.4	46.5	31.0	205	16-4 TRTX-S	16-4TRMTXSS	16-6 TRTX-B	310	350
25	10	1	3/8	1 5/16-12	9/16-18	B	41.0	7.5	46.5	29.5	215	16-6TRTXS	16-6TRMTXSS		310	350
25	12	1	1/2	1 5/16-12	3/4-16	B	38.0	9.9	49.0	32.0	228	16-8 TRTX-S	16-8TRMTXSS		310	350
25	14, 15, 16	1	5/8	1 5/16-12	7/8-14	B	41.0	12.3	52.0	34.5	239	16-10TRTXS	16-10TRMTXSS		310	350
25	18, 20	1	3/4	1 5/16-12	1 1/16-12	B	41.0	15.5	54.5	37.0	252	16-12TRTXS	16-12TRMTXSS	310	280	
25	22	1	7/8	1 5/16-12	1 3/16-12	A	38.0	18.2	48.5	34.0	224	16-14 TRTX-S	16-14TRMTXSS	310	280	
28, 30, 32	12	1 1/4	1/2	1 5/8-12	3/4-16	B	50.0	9.9	54.0	36.0	380	20-8TRTXS	20-8TRMTXSS	20-10 TRTX-B	310	280
28, 30, 32	14, 15, 16	1 1/4	5/8	1 5/8-12	7/8-14	B	50.0	12.3	56.0	38.0	380	20-10TRTXS	20-10TRMTXSS		280	280
28, 30, 32	18, 20	1 1/4	3/4	1 5/8-12	1 1/16-12	B	50.0	15.5	57.0	39.0	370	20-12TRTXS	20-12TRMTXSS		280	280
28, 30, 32	25	1 1/4	1	1 5/8-12	1 5/16-12	B	50.0	21.5	59.0	40.5	355	20-16TRTXS	20-16TRMTXSS		280	280
35, 38	20	1 1/2	3/4	1 7/8-12	1 1/16-12	B	60.0	15.5	63.0	41.5	520	24-12TRTXS	24-12TRMTXSS	24-16 TRTX-B	210	280
35, 38	25	1 1/2	1	1 7/8-12	1 5/16-12	B	57.0	21.5	63.0	41.5	570	24-16 TRTX-S	24-16TRMTXSS		210	140
35, 38	28, 30, 32	1 1/2	1 1/4	1 7/8-12	1 5/8-12	B	57.0	27.4	64.0	43.0	614	24-20 TRTX-S	24-20TRMTXSS		210	140
42	35, 38			2 1/4-12	1 7/8-12	B	65.0	33.3	72.0	48.5	839	28-24TRTXS	28-24TRMTXSS		140	140
50	38	2	1 1/2	2 1/2-12	1 7/8-12	B	73.0	33.3	75.0	48.5	900	32-24 TRTX-S		140	—	

Order codes shown are part of our current manufacturing programme.

Imperial and metric parts may vary in hexagon dimensions.

$$\frac{\text{PN (bar)}}{10} = \text{PN (MPa)}$$

Pressure ratings – PN shown, apply to Steel and Stainless Steel versions of the product.

For Brass parts reduce pressures by 35 %

Do not create drawings from these dimensions, they are subject to change and ISO manufacturing allowances.

HMX6 Swivel nut union

Triple-Lok® 37° Flare female swivel ends

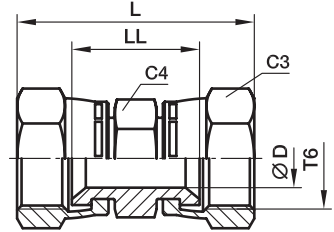

Tube O.D.		Thread UN/UNF-2B T6	C3 mm	C4 mm	D mm	L mm	LL mm	Weight (steel) g/1 piece	Triple-Lok® Steel	Triple-Lok® Stainless Steel	PN (bar)	
mm	in.										S	SS
6	1/4	7/16-20	14.3	14.3	4.4	38	20	27	4 HX6-S	4HMX6SS	500	500
8, 10	5/16, 3/8	9/16-18	17.5	17.5	7.5	45	26	35	6 HX6-S	6HMX6SS	350	350
12	1/2	3/4-16	22.2	22.2	9.9	51	29	64	8 HX6-S	8HMX6SS	350	350
14, 15, 16	5/8	7/8-14	25.4	25.4	12.3	58	32	115	10 HX6-S	10HMX6SS	350	350
18, 20	3/4	1 1/16-12	31.8	31.8	15.5	62	33	185	12 HX6-S	12HMX6SS	350	350
25	1	1 5/16-12	38.0	38.0	21.4	68	38	235	16 HX6-S	16HMX6SS	250	250

Order codes shown are part of our current manufacturing programme.

Imperial and metric parts may vary in hexagon dimensions.

$$\frac{\text{PN (bar)}}{10} = \text{PN (MPa)}$$

Do not create drawings from these dimensions, they are subject to change and ISO manufacturing allowances.

JX6 Swivel nut union tee

Triple-Lok® 37° Flare female swivel ends

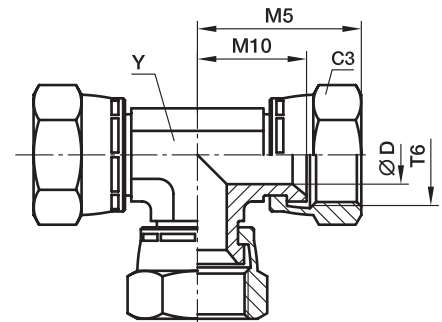

Tube O.D. mm	Tube O.D. in.	Thread UN/UNF-2B T6	C3 mm	D mm	M5 mm	M10 mm	Y mm	Weight (steel) g/1 piece	Triple-Lok® Steel	PN (bar)
6	1/4	7/16-20	14.3	4.4	26	17	11	55	4 JX6-S	500
8, 10	5/16, 3/8	9/16-18	17.5	7.5	32	22	14	85	6 JX6-S	350
12	1/2	3/4-16	22.2	9.9	35	24	19	150	8 JX6-S	350
14, 15, 16	5/8	7/8-14	25.4	12.3	42	29	22	220	10 JX6-S	350
18, 20	3/4	1 1/16-12	31.8	15.5	42	30	27	345	12 JX6-S	350
25	1	1 5/16-12	38.0	21.4	52	36	30	510	16 JX6-S	250

Order codes shown are part of our current manufacturing programme.

Imperial and metric parts may vary in hexagon dimensions.

$$\frac{\text{PN (bar)}}{10} = \text{PN (MPa)}$$

Do not create drawings from these dimensions, they are subject to change and ISO manufacturing allowances.

F87OMX Male stud connector

Triple-Lok® 37° Flare end / Male metric thread – O-ring (ISO 6149)

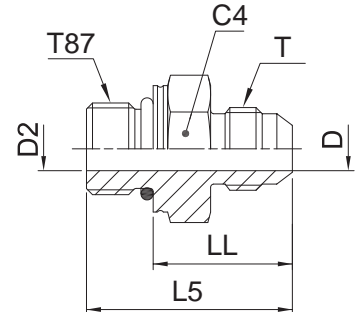

Tube O.D.		Thread Metric T87	Thread UN/UNF-2A T	C4 mm	D mm	D2 mm	L5 mm	LL mm	Weight (steel) g/1 piece	Triple-Lok® Steel	Triple-Lok® Stainless Steel	PN (bar)	
mm	in.											S	SS
6	1/4	M 10×1.0	7/16-20	14	4.4	4.4	30.0	21.5	25	4M10F87OMXS	4M10F87OMXSS	500	350
8	5/16	M 10×1.0	1/2-20	14	4.4	6.0	30.0	21.5	30	5M10F87OMXS	5M10F87OMXSS	420	350
8	5/16	M 12×1.5	1/2-20	19	6.0	6.0	33.0	22.0	37	5M12F87OMXS	5M12F87OMXSS	420	350
8	5/16	M 14×1.5	1/2-20	19	6.0	6.0	34.0	23.0	40	5M14F87OMXS	5M14F87OMXSS	420	350
10	3/8	M 14×1.5	9/16-18	19	7.5	7.5	34.0	23.0	44	6M14F87OMXS	6M14F87OMXSS	420	350
10	3/8	M 16×1.5	9/16-18	22	7.5	7.5	35.5	24.5	53	6M16F87OMXS	6M16F87OMXSS	420	350
10	3/8	M 18×1.5	9/16-18	24	7.5	7.5	36.5	24.0	60	6M18F87OMXS	6M18F87OMXSS	350	350
12	1/2	M 14×1.5	3/4-16	19	9.9	7.5	36.0	25.0	41	8M14F87OMXS	8M14F87OMXSS	420	350
12	1/2	M 16×1.5	3/4-16	22	9.9	9.0	38.0	26.5	57	8M16F87OMXS	8M16F87OMXSS	420	350
12	1/2	M 18×1.5	3/4-16	24	9.9	9.9	39.0	26.5	71	8M18F87OMXS	8M18F87OMXSS	350	350
14, 15, 16	5/8	M 14×1.5	7/8-14	24	12.3	7.5	40.5	29.5	73	10M14F87OMXS	10M14F87OMXSS	350	350
14, 15, 16	5/8	M 18×1.5	7/8-14	24	12.3	11.0	43.0	30.5	75	10M18F87OMXS	10M18F87OMXSS	350	350
14, 15, 16	5/8	M 22×1.5	7/8-14	27	12.3	12.3	43.5	30.5	98	10M22F87OMXS	10M22F87OMXSS	350	350
14, 15, 16	5/8	M 27×2.0	7/8-14	32	12.3	12.3	46.0	30.0	75	10M27F87OMXS	10M27F87OMXSS	350	350
18, 20	3/4	M 22×1.5	1 1/16-12	27	15.5	14.0	48.0	35.0	104	12M22F87OMXS	12M22F87OMXSS	350	350
18, 20	3/4	M 27×2.0	1 1/16-12	32	15.5	15.5	51.0	35.0	158	12M27F87OMXS	12M27F87OMXSS	350	350
25	1	M 27×2.0	1 5/16-12	36	21.5	18.0	50.5	34.5	206	16M27F87OMXS	16M27F87OMXSS	280	280
25	1	M 33×2.0	1 5/16-12	41	21.5	21.5	53.0	37.0	273	16M33F87OMXS	16M33F87OMXSS	280	280
28, 30, 32	1 1/4	M 42×2.0	1 5/8-12	50	27.5	30.0	55.0	39.0	431	20M42F87OMXS	20M42F87OMXSS	280	210
35, 38	1 1/2	M 48×2.0	1 7/8-12	55	33.0	33.0	59.0	41.5	564	24M48F87OMXS	24M48F87OMXSS	210	140

Steel, stainless steel and brass Triple-Lok® parts are delivered with NBR elastomeric seals as standard. For more details on other seal materials see page K92.

Order codes shown are part of our current manufacturing programme.

Imperial and metric parts may vary in hexagon dimensions.

$$\frac{\text{PN (bar)}}{10} = \text{PN (MPa)}$$

Do not create drawings from these dimensions, they are subject to change and ISO manufacturing allowances.

F5OMX Male stud connector

Triple-Lok® 37° Flare end / Male UN/UNF thread – O-ring (ISO 11926)
SAE 070120 MS51525

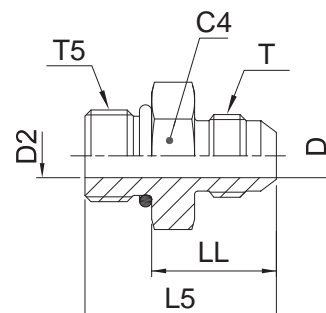

Tube O.D. mm	in.	Thread UN/UNF-2A T5	Thread UN/UNF-2A T	C4 mm	D mm	D2 mm	L5 mm	LL mm	Weight (steel) g/1 piece	Triple-Lok® Steel	Triple-Lok® Stainless Steel	PN (bar)		
												S	SS	
6	1/8	5/16-24	5/16-24	11.0	1.6	1.6	27.0	19.0	8	2 F5OX-S		500	—	
	3/16	3/8-24	3/8-24	13.0	3.0	3.0	28.0	20.0	10	3 F5OX-S		500	—	
	3/16	5/16-24	3/8-24	13.0	3.0	1.6	28.0	20.0	9	3-2 F5OX-S		500	—	
	1/4	7/16-20	7/16-20	14.3	4.4	4.4	31.0	22.0	15	4F5OMXS		4F5OMXSS	500	350
	1/4	3/8-24	7/16-20	14.3	4.4	3.0	30.0	23.0	12	4-3F5OMXS		4-3F5OMXSS	500	350
	1/4	9/16-18	7/16-20	17.0	4.4	4.4	33.0	23.0	27	4-6F5OMXS		4-6F5OMXSS	420	350
6	1/4	3/4-16	7/16-20	22.3	4.4	4.4	35.0	24.0	35	4-8 F5OX-S	4-8F5OMXSS	420	350	
6	1/4	7/8-14	7/16-20	25.5	4.4	4.4	38.0	25.0	60	4-10 F5OX-S	4-10F5OMXSS	350	350	
8	5/16	1/2-20	1/2-20	17.0	6.0	6.0	31.0	22.0	18	5F5OMXS	5F5OMXSS	420	350	
8	5/16	7/16-20	1/2-20	14.0	6.0	4.5	31.0	22.0	18	5-4F5OMXS	5-4F5OMXSS	420	350	
8	5/16	9/16-18	1/2-20	17.5	6.0	6.0	33.0	23.0	25	5-6 F5OX-S	5-6F5OMXSS	420	350	
8	5/16	3/4-16	1/2-20	22.2	6.0	6.0	35.0	24.0	40	5-8 F5OX-S	5-8F5OMXSS	420	350	
10	3/8	9/16-18	9/16-18	17.0	7.5	7.5	33.0	23.0	25	6F5OMXS	6F5OMXSS	420	350	
10	3/8	7/16-20	9/16-18	16.0	7.5	4.4	32.0	23.0	40	6-4 F5OX-S	6-4F5OMXSS	420	350	
10	3/8	1/2-20	9/16-18	16.0	7.5	6.0	32.0	23.0	56	6-5 F5OX-S	6-5F5OMXSS	420	350	
10	3/8	3/4-16	9/16-18	22.0	7.5	7.5	35.0	24.0	44	6-8F5OMXS	6-8F5OMXSS	420	350	
10	3/8	7/8-14	9/16-18	27.0	7.5	7.5	38.0	25.0	85	6-10F5OMXS	6-10F5OMXSS	350	350	
10	3/8	1 1/16-12	9/16-18	31.8	7.5	15.5	42.0	27.0	100	6-12 F5OX-S	6-12F5OMXSS	350	350	
12	1/2	3/4-16	3/4-16	22.0	9.9	9.9	38.0	27.0	58	8F5OMXS	8F5OMXSS	420	350	
12	1/2	7/16-20	3/4-16	20.5	9.9	4.4	38.0	29.0	40	8-4 F5OX-S	8-4F5OMXSS	420	350	
12	1/2	9/16-18	3/4-16	19.0	9.9	7.5	36.5	26.5	44	8-6F5OMXS	8-6F5OMXSS	420	350	
12	1/2	7/8-14	3/4-16	27.0	9.9	9.9	41.0	28.0	73	8-10F5OMXS	8-10F5OMXSS	350	350	
12	1/2	1 1/16-12	3/4-16	32.0	9.9	9.9	45.0	30.0	126	8-12F5OMXS	8-12F5OMXSS	350	350	
12	1/2	1 5/16-12	3/4-16	38.0	9.9	9.9	45.0	30.0	160	8-16 F5OX-S	8-16F5OMXSS	310	310	
14, 15, 16	5/8	7/8-14	7/8-14	27.0	12.3	12.3	43.0	30.5	75	10F5OMXS	10F5OMXSS	350	350	
14, 15, 16	5/8	9/16-18	7/8-14	23.8	12.3	7.5	43.0	33.0	60	10-6 F5OX-S	10-6F5OMXSS	350	350	
14, 15, 16	5/8	3/4-16	7/8-14	24.0	12.3	9.9	42.0	30.5	65	10-8F5OMXS	10-8F5OMXSS	350	350	
14, 15, 16	5/8	1 1/16-12	7/8-14	32.0	12.3	12.3	47.0	32.0	132	10-12F5OMXS	10-12F5OMXSS	350	350	
14, 15, 16	5/8	1 5/16-12	7/8-14	38.0	12.3	12.3	48.0	33.0	170	10-16 F5OX-S	10-16F5OMXSS	310	310	
18, 20	3/4	1 1/16-12	1 1/16-12	32.0	15.5	15.5	50.0	35.0	134	12F5OMXS	12F5OMXSS	350	350	
18, 20	3/4	3/4-16	1 1/16-12	28.6	15.5	9.9	49.0	38.0	104	12-8 F5OX-S	12-8F5OMXSS	350	350	
18, 20	3/4	7/8-14	1 1/16-12	27.0	15.5	12.3	48.0	35.0	108	12-10F5OMXS	12-10F5OMXSS	350	350	
18, 20	3/4	1 3/16-12	1 1/16-12	35.0	15.5	15.5	50.0	35.0	170	12-14 F5OX-S	12-14F5OMXSS	310	310	
18, 20	3/4	1 5/16-12	1 1/16-12	38.0	15.5	21.5	50.5	35.5	197	12-16 F5OX-S	12-16F5OMXSS	310	310	
18, 20	3/4	1 5/8-12	1 1/16-12	47.6	15.5	15.5	53.0	38.0	230	12-20 F5OX-S	12-20F5OMXSS	280	280	
22	7/8	1 3/16-12	1 3/16-12	35.0	18.2	18.2	51.0	36.0	174	14 F5OX-S	14F5OMXSS	280	280	
22	7/8	1 5/16-12	1 3/16-12	38.0	18.2	18.2	51.0	36.0	223	14-16 F5OX-S	14-16F5OMXSS	280	280	
25	1	1 5/16-12	1 5/16-12	41.0	21.5	21.5	52.0	36.5	203	16F5OMXS	16F5OMXSS	280	280	
25	1	3/4-16	1 5/16-12	35.0	21.4	9.9	45.0	34.0	160	16-8 F5OX-S	16-8F5OMXSS	280	280	

Continued on page K28

F5OMX Male stud connector

Triple-Lok® 37° Flare end / Male UN/UNF thread – O-ring (ISO 11926)
SAE 070120 MS51525

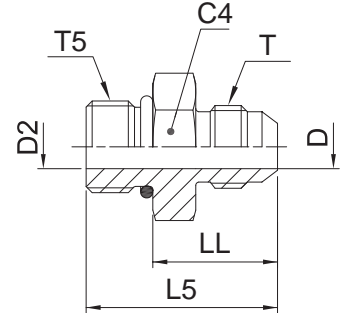

Tube O.D.		Thread UN/UNF-2A T5	Thread UN/UNF-2A T	C4	D	D2	L5	LL	Weight (steel) g/1 piece	Triple-Lok® Steel	Triple-Lok® Stainless Steel	PN (bar)	
mm	in.			mm	mm	mm	mm	mm				S	SS
25	1	7/8-14	1 5/16-12	35.0	21.4	12.3	53	40.0	183	16-10 F5OX-S	16-10F5OMXSS	280	280
25	1	1 1/16-12	1 5/16-12	36.0	21.4	15.5	52	36.5	204	16-12F5OMXS	16-12F5OMXSS	280	280
25	1	1 3/16-12	1 5/16-12	35.0	21.4	18.3	52	37.0	198	16-14 F5OX-S	16-14F5OMXSS	280	280
25	1	1 5/8-12	1 5/16-12	47.6	21.4	21.4	54	39.0	270	16-20 F5OX-S	16-20F5OMXSS	280	280
25	1	1 7/8-12	1 5/16-12	54.0	21.4	21.4	56	41.0	310	16-24 F5OX-S	16-24F5OMXSS	210	210
28, 30, 32	1 1/4	1 5/8-12	1 5/8-12	50.0	27.5	27.5	55	40.0	274	20F5OMXS	20F5OMXSS	280	210
28, 30, 32	1 1/4	1 1/16-12	1 5/8-12	43.0	27.4	15.5	58	43.0	250	20-12 F5OX-S	20-12F5OMXSS	280	210
28, 30, 32	1 1/4	1 5/16-12	1 5/8-12	43.0	27.4	21.4	59	44.0	280	20-16 F5OX-S	20-16F5OMXSS	280	210
28, 30, 32	1 1/4	1 7/8-12	1 5/16-12	54.0	27.4	27.4	57	42.0	454	20-24 F5OX-S		280	210
35, 38	1 1/2	1 7/8-12	1 7/8-12	55.0	33.0	33.0	60	45.0	355	24F5OMXS	24F5OMXSS	210	140
35, 38	1 1/2	1 5/8-12	1 7/8-12	51.0	33.3	27.4	64	49.0	340	24-20 F5OX-S	24-20F5OMXSS	210	140
35, 38	1 1/2	2 1/2-12	1 7/8-12	70.0	33.3	33.3	64	49.0	400	24-32 F5OX-S		140	—
	2	2 1/2-12	2 1/2-12	70.0	45.2	45.2	71	56.0	650	32 F5OX-S		140	—
	2	1 7/8-12	2 1/2-12	66.7	45.2	33.3	75	60.0	600	32-24 F5OX-S		140	—

Steel, stainless steel and brass Triple-Lok® parts are delivered with NBR elastomeric seals as standard. For more details on other seal materials see page K92.

Order codes shown are part of our current manufacturing programme.

Imperial and metric parts may vary in hexagon dimensions.

$$\frac{\text{PN (bar)}}{10} = \text{PN (MPa)}$$

Do not create drawings from these dimensions, they are subject to change and ISO manufacturing allowances.

FF50MX Extended male stud connector

Triple-Lok® 37° Flare end / Male UN/UNF thread – O-ring (ISO 11926)
SAE 070122 MS51526

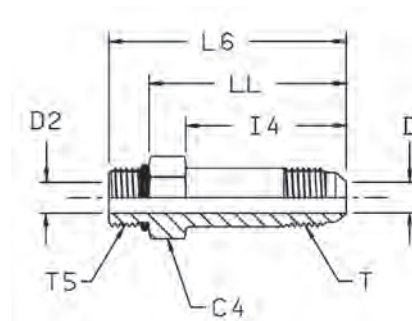

Tube O.D.		Thread UN/UNF-2A T5	Thread UN/UNF-2A T	C4 mm	D mm	D2 mm	I4 mm	L6 mm	LL mm	Weight (steel) g/1 piece	Triple-Lok® Steel	Triple-Lok® Stainless Steel	PN (bar)	
mm	in.												S	SS
6	1/4	7/16-20	7/16-20	14.3	4.4	4.4	35	53	44	33	4 FF50X-S	4 FF50X-SS	500	500
10	3/8	9/16-18	9/16-18	17.5	7.5	7.5	40	59	49	53	6 FF50X-S	6 FF50X-SS	420	420
12	1/2	3/4-16	3/4-16	22.2	9.9	9.9	48	69	58	104	8 FF50X-S	8 FF50X-SS	420	420
14, 15, 16	5/8	7/8-14	7/8-14	25.4	12.3	12.3	53	77	64	151	10 FF50X-S	10 FF50X-SS	350	350
18, 20	3/4	1 1/16-12	1 1/16-12	31.8	15.5	15.5	64	92	77	277	12 FF50X-S	12 FF50X-SS	350	350
25	1	1 5/16-12	1 5/16-12	38.0	21.4	21.4	72	101	86	458	16 FF50X-S	16 FF50X-SS	280	280
28, 30, 32	1 1/4	1 5/8-12	1 5/8-12	47.6	27.4	27.4	88	119	104	862	20 FF50X-S	20 FF50X-SS	280	280

Steel, stainless steel and brass Triple-Lok® parts are delivered with NBR elastomeric seals as standard. For more details on other seal materials see page K92.

Order codes shown are part of our current manufacturing programme.

Imperial and metric parts may vary in hexagon dimensions.

$$\frac{\text{PN (bar)}}{10} = \text{PN (MPa)}$$

Do not create drawings from these dimensions, they are subject to change and ISO manufacturing allowances.

K

F42EDMX Male stud connector

Triple-Lok® 37° Flare end / Male BSPP thread – ED seal (ISO 1179)

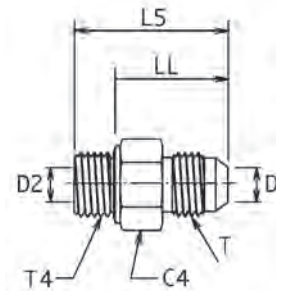

Tube O.D.		Thread BSPP T4	Thread UN/UNF-2A T	C4 mm	D mm	D2 mm	L5 mm	LL mm	Weight (steel) g/1 piece	Triple-Lok® Steel	Triple-Lok® Stainless Steel	PN (bar)	
mm	in.											S	SS
6	1/4	1/8-28	7/16-20	14	4.4	4.4	30.0	22.0	20	4F42EDMXS	4F42EDMXSS	500	350
6	1/4	1/4-19	7/16-20	19	4.4	4.4	35.0	23.0	34	4-4F42EDMXS	4-4F42EDMXSS	420	350
6	1/4	3/8-19	7/16-20	22	4.4	9.0	36.0	24.0	47	4-6F42EDMXS	4-6F42EDMXSS	420	350
6	1/4	1/2-14	7/16-20	27	4.4	14.0	39.5	25.5	99	4-8F42EDMXS	4-8F42EDMXSS	350	350
6	1/4	3/4-14	7/16-20	32	4.4	16.0	43.0	27.0	88	4-12F42EDMXS	4-12F42EDMXSS	350	350
8	5/16	1/8-28	1/2-20	14	6.0	4.0	30.0	22.0	20	5F42EDMXS	5F42EDMXSS	420	350
8	5/16	1/4-19	1/2-20	19	6.0	6.0	35.0	23.0	30	5-4F42EDMXS	5-4F42EDMXSS	420	350
8	5/16	3/8-19	1/2-20	22	6.0	9.0	36.0	24.0	47	5-6F42EDMXS	5-6F42EDMXSS	420	350
10	3/8	1/4-19	9/16-18	19	7.5	6.0	35.0	23.0	28	6F42EDMXS	6F42EDMXSS	420	350
10	3/8	1/8-28	9/16-18	17	7.5	4.0	31.0	23.0	27	6-2F42EDMXS	6-2F42EDMXSS	420	350
10	3/8	3/8-19	9/16-18	22	7.5	7.5	36.0	24.0	40	6-6F42EDMXS	6-6F42EDMXSS	420	350
10	3/8	1/2-14	9/16-18	27	7.5	14.0	39.5	25.5	95	6-8F42EDMXS	6-8F42EDMXSS	350	350
10	3/8	3/4-14	9/16-18	32	7.5	16.0	45.5	29.5	100	6-12F42EDMXS	6-12F42EDMXSS	350	350
12	1/2	3/8-19	3/4-16	22	9.9	9.0	38.5	26.5	50	8F42EDMXS	8F42EDMXSS	420	350
12	1/2	1/4-19	3/4-16	19	9.9	6.0	39.0	27.0	40	8-4F42EDMXS	8-4F42EDMXSS	420	350
12	1/2	1/2-14	3/4-16	27	9.9	9.9	42.0	28.0	100	8-8F42EDMXS	8-8F42EDMXSS	350	350
12	1/2	3/4-14	3/4-16	32	9.9	16.0	46.0	30.0	100	8-12F42EDMXS	8-12F42EDMXSS	350	350
12	1/2	1-11	3/4-16	41	9.9	23.0	53.0	35.0	150	8-16F42EDMXS	8-16F42EDMXSS	280	280
14, 15, 16	5/8	1/2-14	7/8-14	27	12.3	12.3	45.0	31.0	103	10F42EDMXS	10F42EDMXSS	350	350
14, 15, 16	5/8	1/4-19	7/8-14	24	12.3	6.0	41.0	29.0	110	10-4F42EDMXS	10-4F42EDMXSS	350	350
14, 15, 16	5/8	3/8-19	7/8-14	24	12.3	9.0	43.0	31.0	65	10-6F42EDMXS	10-6F42EDMXSS	350	350
14, 15, 16	5/8	3/4-14	7/8-14	32	12.3	16.0	48.0	32.0	160	10-12F42EDMXS	10-12F42EDMXSS	350	350
14, 15, 16	5/8	1-11	7/8-14	41	12.3	23.0	51.0	33.0	205	10-16F42EDMXS	10-16F42EDMXSS	280	280
18, 20	3/4	3/4-14	1 1/16-12	32	15.5	15.5	51.0	35.0	165	12F42EDMXS	12F42EDMXSS	350	350
18, 20	3/4	3/8-19	1 1/16-12	27	15.5	9.0	50.0	38.0	105	12-6F42EDMXS	12-6F42EDMXSS	350	350
18, 20	3/4	1/2-14	1 1/16-12	27	15.5	14.0	49.0	35.0	118	12-8F42EDMXS	12-8F42EDMXSS	350	350
18, 20	3/4	1-11	1 1/16-12	41	15.5	23.0	53.5	34.5	292	12-16F42EDMXS	12-16F42EDMXSS	280	280
18, 20	3/4	1 1/4-11	1 1/16-12	50	15.5	30.0	62.0	42.0	220	12-20F42EDMXS	12-20F42EDMXSS	280	210
22	7/8	3/4-14	1 3/16-12	32	18.0	18.0	51.0	35.0	173	14F42EDMXS	14F42EDMXSS	280	280
25	1	1-11	1 5/16-12	41	21.5	21.5	55.0	37.0	262	16F42EDMXS	16F42EDMXSS	280	280
25	1	1/2-14	1 5/16-12	36	21.5	14.0	54.0	40.0	145	16-8F42EDMXS	16-8F42EDMXSS	280	280
25	1	3/4-14	1 5/16-12	36	21.5	16.0	53.0	37.0	217	16-12F42EDMXS	16-12F42EDMXSS	280	280
25	1	1 1/4-11	1 5/16-12	50	21.5	25.0	59.0	39.0	386	16-20F42EDMXS	16-20F42EDMXSS	280	280
28, 30, 32	1 1/4	1 1/4-11	1 5/8-12	50	27.5	25.0	60.0	40.0	375	20F42EDMXS	20F42EDMXSS	280	210
28, 30, 32	1 1/4	3/4-14	1 5/8-12	46	27.5	16.0	59.5	43.5	220	20-12F42EDMXS	20-12F42EDMXSS	280	210
28, 30, 32	1 1/4	1-11	1 5/8-12	46	27.5	23.0	62.0	44.0	255	20-16F42EDMXS	20-16F42EDMXSS	280	210
28, 30, 32	1 1/4	1 1/2-11	1 5/8-12	55	27.5	32.0	64.0	42.0	420	20-24F42EDMXS	20-24F42EDMXSS	210	140
35, 38	1 1/2	1 1/2-11	1 7/8-12	55	33.0	32.0	67.0	45.0	480	24F42EDMXS	24F42EDMXSS	210	140
35, 38	1 1/2	1-11	1 7/8-12	50	33.0	23.0	63.0	45.0	390	24-16F42EDMXS	24-16F42EDMXSS	210	210
35, 38	1 1/2	1 1/4-11	1 7/8-12	50	33.0	30.0	62.0	42.0	420	24-20F42EDMXS	24-20F42EDMXSS	210	210
42		1 1/2-11	2 1/4-12	60	39.0	36.0	71.0	49.0	746	28-24F42EDMXS	28-24F42EDMXSS	140	105

Steel, stainless steel and brass Triple-Lok® parts are delivered with NBR elastomeric seals as standard. For more details on other seal materials see page K92.

Order codes shown are part of our current manufacturing programme. Imperial and metric parts may vary in hexagon dimensions.

$$\frac{\text{PN (bar)}}{10} = \text{PN (MPa)}$$

Do not create drawings from these dimensions, they are subject to change and ISO manufacturing allowances.

FF42EDMX Extended male stud connector

Triple-Lok® 37° Flare end / Male BSPP thread - ED seal (ISO 1179-2)

SAE 070122

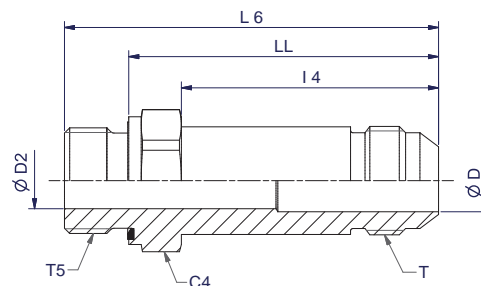

Tube O.D.		Thread UN/UNF-2A T	Thread BSPP T5	C4 mm	D mm	D2 mm	I4 mm	L6 mm	LL mm	Weight (steel) g/1 piece	Triple-Lok® Steel	Triple-Lok® Stainless Steel	PN (bar)	
mm	inch												S	SS
10	3/8	9/16-18	1/4-19	19	8	6	40	61	49	60	6FF42EDMXS	6FF42EDMXSS	420	350
12	1/2	3/4-16	3/8-19	22	10	9	48	70	58	100	8FF42EDMXS	8FF42EDMXSS	420	350
14, 15, 16	5/8	7/8-14	1/2-14	27	12	12	53	79	65	170	10FF42EDMXS	10FF42EDMXSS	350	350
18, 20	3/4	1 1/16-12	3/4-14	32	16	16	64	93	77	280	12FF42EDMXS	12FF42EDMXSS	350	350

Steel, stainless steel and brass Triple-Lok® parts are delivered with NBR elastomeric seals as standard. For more details on other materials see page K92.

Order codes shown are part of our current manufacturing programme.

Imperial and metric parts may vary in hexagon dimensions.

$$\frac{\text{PN (bar)}}{10} = \text{PN (MPa)}$$

Do not create drawings from these dimensions, they are subject to change and ISO manufacturing allowances.

F4OMX Male stud connector

Triple-Lok® 37° Flare end / Male BSPP thread – O-ring + retaining ring (ISO 1179)

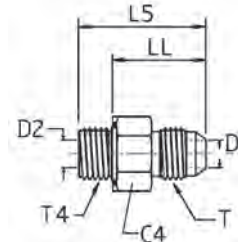

Tube O.D.		Thread BSPP T4	Thread UN/UNF-2A T	C4 mm	D mm	D2 mm	L5 mm	LL mm	Weight (steel) g/1 piece	Triple-Lok® Steel	Triple-Lok® Stainless Steel	PN (bar)	
mm	in.											S	SS
6	1/4	1/8-28	7/16-20	17	4.4	4.4	28.0	21.0	20	4F4OMXS	4F4OMXSS	350	350
6	1/4	1/4-19	7/16-20	19	4.4	4.4	32.0	21.0	34	4-4F4OMXS	4-4F4OMXSS	350	350
6	1/4	3/8-19	7/16-20	22	4.4	4.4	33.0	22.0	47	4-6F4OMXS	4-6F4OMXSS	350	350
6	1/4	1/2-14	7/16-20	30	4.4	4.4	39.0	24.0	99	4-8F4OMXS	4-8F4OMXSS	350	350
8	5/16	1/8-28	1/2-20	17	6.0	4.4	28.0	21.0	25	5F4OMXS	5F4OMXSS	350	350
8	5/16	1/4-19	1/2-20	19	6.0	6.0	32.0	21.0	30	5-4F4OMXS	5-4F4OMXSS	350	350
8	5/16	3/8-19	1/2-20	22	6.0	6.0	33.0	22.0	47	5-6F4OMXS	5-6F4OMXSS	350	350
10	3/8	1/4-19	9/16-18	19	7.5	6.0	32.5	21.0	28	6F4OMXS	6F4OMXSS	350	350
10	3/8	1/8-28	9/16-18	17	7.5	4.4	29.0	22.0	27	6-2F4OMXS	6-2F4OMXSS	350	350
10	3/8	3/8-19	9/16-18	22	7.5	7.5	33.0	22.0	40	6-6F4OMXS	6-6F4OMXSS	350	350
10	3/8	1/2-14	9/16-18	30	7.5	7.5	38.0	23.5	25	6-8F4OMXS	6-8F4OMXSS	350	350
10	3/8	3/4-14	9/16-18	36	7.5	7.5	39.5	25.0	100	6-12F4OMXS	6-12F4OMXSS	280	280
12	1/2	3/8-19	3/4-16	22	9.9	9.9	36.0	25.0	50	8F4OMXS	8F4OMXSS	350	350
12	1/2	1/4-19	3/4-16	19	9.9	6.0	41.0	24.0	40	8-4F4OMXS	8-4F4OMXSS	350	350
12	1/2	1/2-14	3/4-16	30	9.9	9.9	41.0	27.0	100	8-8F4OMXS	8-8F4OMXSS	350	350
12	1/2	3/4-14	3/4-16	36	9.9	9.9	42.0	28.5	100	8-12F4OMXS	8-12F4OMXSS	280	250
12	1/2	1-11	3/4-16	46	9.9	9.9	47.0	29.0	150	8-16F4OMXS	8-16F4OMXSS	280	250
14, 15, 16	5/8	1/2-14	7/8-14	30	12.3	12.3	43.0	28.5	103	10F4OMXS	10F4OMXSS	350	350
14, 15, 16	5/8	1/4-19	7/8-14	24	12.3	6.0	39.0	28.0	110	10-4F4OMXS	10-4F4OMXSS	350	350
14, 15, 16	5/8	3/8-19	7/8-14	24	12.3	9.0	39.0	28.0	65	10-6F4OMXS	10-6F4OMXSS	350	350
14, 15, 16	5/8	3/4-14	7/8-14	36	12.3	12.3	45.0	30.5	160	10-12F4OMXS	10-12F4OMXSS	280	250
18, 20	3/4	3/4-14	1 1/16-12	36	15.5	15.5	47.5	33.0	165	12F4OMXS	12F4OMXSS	280	250
18, 20	3/4	3/8-19	1 1/16-12	27	15.5	9.0	44.0	34.0	97	12-6F4OMXS	12-6F4OMXSS	350	250
18, 20	3/4	1/2-14	1 1/16-12	30	15.5	12.0	47.0	32.0	118	12-8F4OMXS	12-8F4OMXSS	350	350
18, 20	3/4	1-11	1 1/16-12	46	15.5	15.5	52.5	34.0	292	12-16F4OMXS	12-16F4OMXSS	280	250
18, 20	3/4	1 1/4-11	1 1/16-12	50	15.5	15.5	53.0	34.5	220	12-20F4OMXS	12-20F4OMXSS	250	175
25	1	1-11	1 5/16-12	46	21.5	21.5	53.5	35.0	262	16F4OMXS	16F4OMXSS	280	250
25	1	1/2-14	1 5/16-12	36	21.5	12.0	48.5	34.0	145	16-8F4OMXS	16-8F4OMXSS	280	250
25	1	3/4-14	1 5/16-12	36	21.5	15.5	48.5	34.0	173	16-12F4OMXS	16-12F4OMXSS	280	250
25	1	1 1/4-11	1 5/16-12	50	27.5	27.5	56.0	37.5	386	16-20F4OMXS	16-20F4OMXSS	250	175
28, 30, 32	1 1/4	1 1/4-11	1 5/8-12	50	27.5	27.5	56.0	37.5	325	20F4OMXS	20F4OMXSS	250	175
28, 30, 32	1 1/4	3/4-14	1 5/8-12	46	27.5	15.5	51.0	36.5	220	20-12F4OMXS	20-12F4OMXSS	280	175
28, 30, 32	1 1/4	1-11	1 5/8-12	46	27.5	15.5	51.0	37.0	330	20-16F4OMXS	20-16F4OMXSS	280	210
28, 30, 32	1 1/4	1 1/2-11	1 5/8-12	55	27.5	27.5	57.0	38.5	480	20-24F4OMXS	20-24F4OMXSS	210	140
35, 38	1 1/2	1 1/2-11	1 7/8-12	55	33.0	33.0	61.0	42.5	480	24F4OMXS	24F4OMXSS	210	140
35, 38	1 1/2	1 1/4-11	1 7/8-12	50	33.0	27.5	60.5	42.0	420	24-20F4OMXS	24-20F4OMXSS	210	140
42	1 1/2	1 1/2-11	2 1/4	60	39.0	33.0	67.5	49.0	740	28-24F4OMXS	28-24F4OMXSS	140	105

Steel, stainless steel and brass Triple-Lok® parts are delivered with NBR elastomeric seals as standard. For more details on other seal materials see page K92.

Order codes shown are part of our current manufacturing programme.

Imperial and metric parts may vary in hexagon dimensions.

$$\frac{\text{PN (bar)}}{10} = \text{PN (MPa)}$$

Do not create drawings from these dimensions, they are subject to change and ISO manufacturing allowances.

F82EDMX Male stud connector

Triple-Lok® 37° Flare end / Male metric thread – ED seal (ISO 9974)

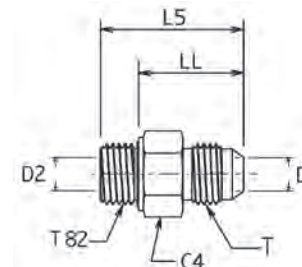

Tube O.D.		Thread Metric T82	Thread UN/UNF-2A T	C4 mm	D mm	D2 mm	L5 mm	LL mm	Weight (steel) g/1 piece	Triple-Lok®		PN (bar)	
mm	in.									Steel	Stainless Steel	S	SS
6	1/4	M 10×1.0	7/16-20	14	4.4	4	30.0	22.0	19	4M10F82EDMXS	4M10F82EDMXSS	500	350
6	1/4	M 12×1.5	7/16-20	17	4.4	6	34.0	22.0	30	4M12F82EDMXS	4M12F82EDMXSS	420	350
8	5/16	M 10×1.0	1/2-20	14	6.0	4	30.0	22.0	17	5M10F82EDMXS	5M10F82EDMXSS	420	350
8	5/16	M 12×1.5	1/2-20	17	6.0	6	34.0	22.0	28	5M12F82EDMXS	5M12F82EDMXSS	420	350
8	5/16	M 14×1.5	1/2-20	19	6.0	7	35.0	23.0	35	5M14F82EDMXS	5M14F82EDMXSS	420	350
10	3/8	M 12×1.5	9/16-18	17	7.5	6	35.0	23.0	33	6M12F82EDMXS	6M12F82EDMXSS	420	350
10	3/8	M 14×1.5	9/16-18	19	7.5	7	35.0	23.0	38	6M14F82EDMXS	6M14F82EDMXSS	420	350
10	3/8	M 16×1.5	9/16-18	22	7.5	9	36.0	24.0	53	6M16F82EDMXS	6M16F82EDMXSS	420	350
10	3/8	M 18×1.5	9/16-18	24	7.5	11	36.0	24.0	60	6M18F82EDMXS	6M18F82EDMXSS	350	350
10	3/8	M 22×1.5	9/16-18	27	7.5	14	39.5	25.5	68	6M22F82EDMXS	6M22F82EDMXSS	350	350
12	1/2	M 14×1.5	3/4-16	19	9.9	7	38.5	26.5	41	8M14F82EDMXS	8M14F82EDMXSS	420	350
12	1/2	M 16×1.5	3/4-16	22	9.9	9	38.5	26.5	57	8M16F82EDMXS	8M16F82EDMXSS	420	350
12	1/2	M 18×1.5	3/4-16	24	9.9	11	38.5	26.5	71	8M18F82EDMXS	8M18F82EDMXSS	350	350
12	1/2	M 22×1.5	3/4-16	27	9.9	14	42.0	28.0	70	8M22F82EDMXS	8M22F82EDMXSS	350	350
14, 15, 16	5/8	M 18×1.5	7/8-14	24	12.3	11	42.5	30.5	104	10M18F82EDMXS	10M18F82EDMXSS	350	350
14, 15, 16	5/8	M 22×1.5	7/8-14	27	12.3	14	44.5	30.5	161	10M22F82EDMXS	10M22F82EDMXSS	350	350
18, 20	3/4	M 18×1.5	1 1/16-12	27	15.5	11	44.5	32.5	85	12M18F82EDMXS	12M18F82EDMXSS	350	350
18, 20	3/4	M 22×1.5	1 1/16-12	27	15.5	14	49.0	35.0	273	12M22F82EDMXS	12M22F82EDMXSS	350	350
18, 20	3/4	M 26×1.5	1 1/16-12	32	15.5	18	51.0	35.0	135	12M26F82EDMXS	12M26F82EDMXSS	350	350
18, 20	3/4	M 27×2.0	1 1/16-12	32	15.5	16	51.0	35.0	431	12M27F82EDMXS	12M27F82EDMXSS	350	350
25	1	M 26×1.5	1 5/16-12	36	21.5	18	55.0	39.0	350	16M26F82EDMXS	16M26F82EDMXSS	280	280
25	1	M 27×2.0	1 5/16-12	36	21.5	16	52.5	36.5	360	16M27F82EDMXS	16M27F82EDMXSS	280	280
25	1	M 33×2.0	1 5/16-12	41	21.5	23	54.5	36.5	431	16M33F82EDMXS	16M33F82EDMXSS	280	280
28, 30, 32	1 1/4	M 42×2.0	1 5/8-12	50	27.5	30	60.0	40.0	431	20M42F82EDMXS	20M42F82EDMXSS	280	210
35, 38	1 1/2	M 48×2.0	1 7/8-12	55	33.0	36	67.0	45.0	580	24M48F82EDMXS	24M48F82EDMXSS	210	140

Steel, stainless steel and brass Triple-Lok® parts are delivered with NBR elastomeric seals as standard. For more details on other seal materials see page K92.

Order codes shown are part of our current manufacturing programme.

Imperial and metric parts may vary in hexagon dimensions.

$$\frac{\text{PN (bar)}}{10} = \text{PN (MPa)}$$

Do not create drawings from these dimensions, they are subject to change and ISO manufacturing allowances.

F8OMX Male stud connector

Triple-Lok® 37° Flare end / Male metric thread – O-ring + retainer ring

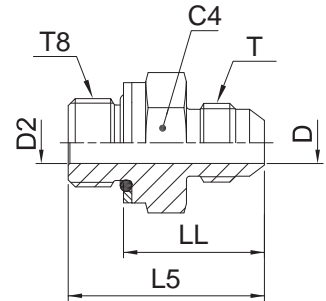

Tube O.D. mm	Tube O.D. in.	Thread Metric T8	Thread UN/UNF-2A T	C4 mm	D mm	D2 mm	L5 mm	LL mm	Weight (steel) g/1 piece	Triple-Lok® Steel	Triple-Lok® Stainless Steel	PN (bar)	
												S	SS
6	1/4	M 10×1.0	7/16-20	14	4.4	4.4	30.0	21.5	25	4M10F8OMXS	4M10F8OMXSS	350	350
6	1/4	M 12×1.5	7/16-20	17	4.4	6.0	33.0	22.0	35	4M12F8OMXS	4M12F8OMXSS	420	350
8	5/16	M 10×1.0	1/2-20	14	6.0	4.5	30.0	21.5	25	5M10F8OMXS	5M10F8OMXSS	350	350
8	5/16	M 12×1.5	1/2-20	19	6.0	6.0	33.0	22.0	35	5M12F8OMXS	5M12F8OMXSS	420	350
8	5/16	M 14×1.5	1/2-20	19	6.0	6.0	34.0	24.0	35	5M14F8OMXS	5M14F8OMXSS	350	350
10	3/8	M 12×1.5	9/16-18	17	7.5	6.0	34.0	23.0	35	6M12F8OMXS	6M12F8OMXSS	420	350
10	3/8	M 14×1.5	9/16-18	19	7.5	7.5	34.0	23.0	35	6M14F8OMXS	6M14F8OMXSS	350	350
10	3/8	M 16×1.5	9/16-18	22	7.5	9.0	35.5	24.0	51	6M16F8OMXS	6M16F8OMXSS	350	350
10	3/8	M 18×1.5	9/16-18	24	7.5	11.0	36.5	24.0	60	6M18F8OMXS	6M18F8OMXSS	250	350
12	1/2	M 14×1.5	3/4-16	19	9.9	7.5	36.0	25.0	38	8M14F8OMXS	8M14F8OMXSS	350	350
12	1/2	M 16×1.5	3/4-16	22	9.9	9.0	38.0	26.5	55	8M16F8OMXS	8M16F8OMXSS	350	350
12	1/2	M 18×1.5	3/4-16	24	9.9	11.0	39.0	26.5	66	8M18F8OMXS	8M18F8OMXSS	250	250
12	1/2	M 22×1.5	3/4-16	27	9.9	14.0	41.0	28.0	70	8M22F8OMXS	8M22F8OMXSS	250	250
14, 15, 16	5/8	M 18×1.5	7/8-14	24	12.3	11.0	43.0	30.5	71	10M18F8OMXS	10M18F8OMXSS	250	250
14, 15, 16	5/8	M 20×1.5	7/8-14	27	12.3	11.0	44.5	33.0	90	10M20F8OMXS	10M20F8OMXSS	250	250
14, 15, 16	5/8	M 22×1.5	7/8-14	27	12.3	14.0	43.5	30.5	98	10M22F8OMXS	10M22F8OMXSS	250	250
18, 20	3/4	M 18×1.5	1 1/16-12	27	15.5	11.0	50.5	38.0	85	12M18F8OMXS	12M18F8OMXSS	250	250
18, 20	3/4	M 22×1.5	1 1/16-12	27	15.5	14.0	48.0	35.0	104	12M22F8OMXS	12M22F8OMXSS	250	250
18, 20	3/4	M 24×1.5	1 1/16-12	30	15.5	14.0	44.5	32.5	120	12M26F8OMXS	12M26F8OMXSS	210	210
18, 20	3/4	M 27×2.0	1 1/16-12	32	15.5	18.0	51.0	35.0	154	12M27F8OMXS	12M27F8OMXSS	210	210
25	1	M 22×1.5	1 5/16-12	36	21.5	14.0	47.5	34.5	180	16M22F8OMXS	16M22F8OMXSS	250	250
25	1	M 26×1.5	1 5/16-12	36	21.5	15.5	51.5	34.5	202	16M26F8OMXS	16M26F8OMXSS	210	210
25	1	M 27×2.0	1 5/16-12	36	21.5	18.0	50.5	34.5	202	16M27F8OMXS	16M27F8OMXSS	210	210
25	1	M 33×2.0	1 5/16-12	41	21.5	23.0	53.0	37.0	267	16M33F8OMXS	16M33F8OMXSS	210	210
28, 30, 32	1 1/4	M 42×2.0	1 5/8-12	50	27.5	30.0	55.0	39.0	427	20M42F8OMXS	20M42F8OMXSS	210	210
35, 38	1 1/2	M 48×2.0	1 7/8-12	55	33.0	36.0	59.5	42.0	545	24M48F8OMXS	24M48F8OMXSS	140	140

Steel, stainless steel and brass Triple-Lok® parts are delivered with NBR elastomeric seals as standard. For more details on other seal materials see page K92.

Order codes shown are part of our current manufacturing programme.

Imperial and metric parts may vary in hexagon dimensions.

$$\frac{\text{PN (bar)}}{10} = \text{PN (MPa)}$$

Pressure ratings – PN shown, apply to Steel and Stainless Steel versions of the product.

Do not create drawings from these dimensions, they are subject to change and ISO manufacturing allowances.

FMTX Male stud connector

Triple-Lok® 37° Flare end / Male NPTF* thread (SAE 476)

SAE 070102 MS51500

*Stainless Steel = NPT to prevent galling

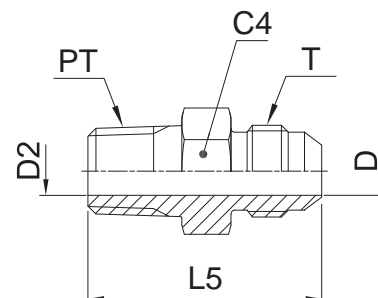

Tube O.D.		Thread NPT/NPTF PT	Thread UN/UNF-2A T	C4 mm	D mm	D2 mm	L5 mm	Weight (steel) g/1 piece	Triple-Lok® Steel	Triple-Lok® Stainless Steel	PN (bar)	
mm	in.										S	SS
5	1/8	1/8-27	5/16-24	11.0	1.6	4.7	28.0	10	2 FTX-S		420	—
	3/16	1/8-27	3/8-24	11.0	3.0	3.0	29.0	12	3 FTX-S		420	—
	1/4	1/8-27	7/16-20	13.0	4.4	4.4	31.0	14	4FMTXS	4FMTXSS	420	350
	1/4	1/4-18	7/16-20	14.0	4.4	4.4	36.0	26	4-4FMTXS	4-4FMTXSS	420	350
	1/4	3/8-18	7/16-20	19.0	4.4	4.4	36.5	26	4-6 FTX-S	4-6FMTXSS	420	350
6	1/4	1/2-14	7/16-20	22.3	4.4	4.4	43.0	26	4-8 FTX-S	4-8FMTXSS	420	350
	5/16	1/8-27	1/2-20	14.0	6.0	5.0	31.0	17	5FMTXS	5FMTXSS	420	350
	5/16	1/4-18	1/2-20	14.0	6.0	6.0	36.0	25	5-4FMTXS	5-4FMTXSS	420	350
	5/16	3/8-18	1/2-20	19.0	6.0	6.0	36.0	30	5-6FMTXS	5-6FMTXSS	420	350
	3/8	1/4-18	9/16-18	17.0	7.5	7.5	36.5	25	6FMTXS	6FMTXSS	420	350
10	3/8	1/8-27	9/16-18	16.0	7.5	4.7	31.5	21	6-2 FTX-S	6-2FMTXSS	420	350
	3/8	3/8-18	9/16-18	19.0	7.5	7.5	36.5	39	6-6FMTXS	6-6FMTXSS	420	350
	3/8	1/2-14	9/16-18	22.0	7.5	7.5	43.0	47	6-8FMTXS	6-8FMTXSS	420	350
	3/8	3/4-14	9/16-18	28.6	7.5	15.5	42.0	109	6-12 FTX-S	6-12FMTXSS	420	350
	1/2	3/8-18	3/4-16	19.0	9.9	9.9	39.0	45	8FMTXS	8FMTXSS	420	350
12	1/2	1/4-18	3/4-16	19.0	9.9	7.0	39.0	42	8-4FMTXS	8-4FMTXSS	420	350
	1/2	3/4-14	3/4-16	22.0	9.9	9.9	45.5	74	8-8FMTXS	8-8FMTXSS	420	350
	1/2	3/4-14	3/4-16	27.0	9.9	9.9	47.0	121	8-12FMTXS	8-12FMTXSS	380	350
	5/8	1/2-14	7/8-14	24.0	12.3	12.3	48.0	77	10FMTXS	10FMTXSS	350	350
	5/8	3/8-18	7/8-14	24.0	12.3	10.0	43.0	63	10-6FMTXS	10-6FMTXSS	350	350
14, 15, 16	5/8	3/4-14	7/8-14	27.0	12.3	12.3	49.5	122	10-12FMTXS	10-12FMTXSS	350	350
	3/4	3/4-14	1 1/16-12	27.0	15.5	15.5	53.0	123	12FMTXS-S	12FMTXSS	350	350
	3/4	3/8-18	1 1/16-12	28.5	15.5	10.3	47.5	90	12-6 FTX-S	12-6FMTXSS	350	350
	3/4	1/2-14	1 1/16-12	28.5	15.5	13.5	52.0	103	12-8 FTX-S	12-8FMTXSS	350	350
	3/4	1-11.5	1 1/16-12	35.0	15.5	15.5	57.0	176	12-16 FTX-S	12-16FMTXSS	310	280
22	7/8	3/4-14	1 3/16-12	31.7	18.3	18.3	53.0	137	14 FTX-S	14FMTXSS	280	245
	1	1-11.5	1 5/16-12	36.0	21.5	21.5	58.5	189	16FMTXS	16FMTXSS	280	280
	1	1/2-14	1 5/16-12	36.0	21.5	18.0	53.5	110	16-8 FTX-S	16-8FMTXSS	280	280
	1	3/4-14	1 5/16-12	36.0	21.5	18.0	53.5	149	16-12FMTXS	16-12FMTXSS	280	280
	1	1 1/4-11.5	1 5/16-12	47.6	21.4	21.4	54.0	331	16-20 FTX-S	16-20FMTXSS	280	280
28, 30, 32	1 1/4	1 1/4-11.5	1 5/8-12	46.0	27.5	32.0	62.0	315	20FMTXS	20FMTXSS	210	210
	1 1/4	1-11.5	1 5/8-12	43.0	27.5	23.8	61.5	248	20-16 FTX-S	20-16FMTXSS	280	210
	1 1/2	1 1/2-11.5	1 7/8-12	50.0	33.0	38.0	68.0	430	24FMTXS	24FMTXSS	210	140
	1 1/2	1-11.5	1 7/8-12	51.0	33.3	24.0	66.5	310	24-16 FTX-S	24-16FMTXSS	210	140
	1 1/2	1 1/4-11.5	1 7/8-12	51.0	33.3	31.7	67.5	359	24-20 FTX-S	24-20FMTXSS	210	140
35, 38	1 1/2	2-11.5	1 7/8-12	66.7	33.3	33.3	72.5	720	24-32 FTX-S	24-32FMTXSS	140	140
	2	2-11.5	2 1/2-12	66.7	45.2	45.2	79.0	858	32 FTX-S	32FMTXSS	140	105
	2	1 1/2-11.5	2 1/2-12	66.7	45.2	38.0	78.0	720	32-24 FTX-S	32-24FMTXSS	140	105

Order codes shown are part of our current manufacturing programme.

Imperial and metric parts may vary in hexagon dimensions.

$$\frac{\text{PN (bar)}}{10} = \text{PN (MPa)}$$

Pressure ratings – PN shown, apply to Steel and Stainless Steel versions of the product.

For Brass parts reduce pressures by 35%.

Do not create drawings from these dimensions, they are subject to change and ISO manufacturing allowances.

F3MX Male stud connector

Triple-Lok® 37° Flare end / Male BSPT thread (ISO 7)

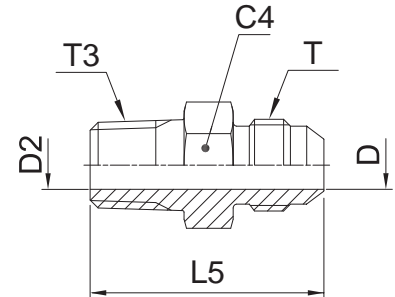

Tube O.D.		Thread BSPT T3	Thread UN/UNF-2A T	C4 mm	D mm	D2 mm	L5 mm	Weight (steel) g/1 piece	Triple-Lok® Steel	Triple-Lok® Stainless Steel	PN (bar)	
mm	in.										S	SS
6	1/4	1/8-28	7/16-20	13	4.4	4.4	31.0	13	4F3MXS	4F3MXSS	315	315
6	1/4	1/4-19	7/16-20	14	4.4	4.4	35.5	25	4-4F3MXS	4-4F3MXSS	315	315
8	5/16	1/8-28	1/2-20	14	6.0	7.0	35.0	17	5F3MXS	5F3MXSS	315	315
8	5/16	1/4-19	1/2-20	14	6.0	7.0	35.0	24	5-4F3MXS	5-4F3MXSS	315	315
10	3/8	1/4-19	9/16-18	17	7.5	7.0	35.5	25	6F3MXS	6F3MXSS	315	315
10	3/8	3/8-19	9/16-18	19	7.5	10.0	35.5	37	6-6F3MXS	6-6F3MXSS	315	315
10	3/8	1/2-14	9/16-18	22	7.5	13.5	43.0	45	6-8F3MXS	6-8F3MXSS	315	315
12	1/2	3/8-19	3/4-16	19	9.9	10.0	39.0	43	8F3MXS	8F3MXSS	315	315
12	1/2	1/4-19	3/4-16	19	9.9	7.0	38.0	41	8-4F3MXS	8-4F3MXSS	315	315
12	1/2	1/2-14	3/4-16	22	9.9	13.5	45.5	71	8-8F3MXS	8-8F3MXSS	315	315
14, 15, 16	5/8	1/2-14	7/8-14	24	12.3	13.5	48.0	74	10F3MXS	10F3MXSS	315	315
14, 15, 16	5/8	3/8-19	7/8-14	24	12.3	10.0	43.0	61	10-6F3MXS	10-6F3MXSS	315	315
14, 15, 16	5/8	3/4-14	7/8-14	27	12.3	18.0	48.5	117	10-12F3MXS	10-12F3MXSS	160	160
18, 20	3/4	3/4-14	1 1/16-12	27	15.5	18.0	51.0	119	12F3MXS	12F3MXSS	160	160
18, 20	3/4	1/2-14	1 1/16-12	27	15.5	13.5	51.0	100	12-8F3MXS	12-8F3MXSS	315	315
18, 20	3/4	1-11	1 1/16-12	36	15.5	24.0	57.0	214	12-16F3MXS	12-16F3MXSS	160	160
25	1	1-11	1 5/16-12	36	21.5	24.0	58.5	185	16F3MXS	16F3MXSS	160	160
25	1	3/4-14	1 5/16-12	36	21.5	18.0	53.5	146	16-12F3MXS	16-12F3MXSS	160	160
28, 30, 32	1 1/4	1 1/4-11	1 5/8-12	46	27.5	32.0	62.0	309	20F3MXS	20F3MXSS	160	160
28, 30, 32	1 1/4	1-11	1 5/8-12	46	27.5	24.0	61.5	243	20-16F3MXS	20-16F3MXSS	160	160
35, 38	1 1/2	1 1/2-11	1 7/8-12	50	33.0	38.0	68.0	421	24F3MXS	24F3MXSS	160	140
35, 38	1 1/2	1 1/4-11	1 7/8-12	50	33.0	32.0	67.0	352	24-20F3MXS	24-20F3MXSS	160	140

Order codes shown are part of our current manufacturing programme.

Imperial and metric parts may vary in hexagon dimensions.

$$\frac{\text{PN (bar)}}{10} = \text{PN (MPa)}$$

Do not create drawings from these dimensions, they are subject to change and ISO manufacturing allowances.

F687OMX Swivel male stud

Triple-Lok® 37° Flare female swivel end / Male metric thread – O-ring (ISO 6149)

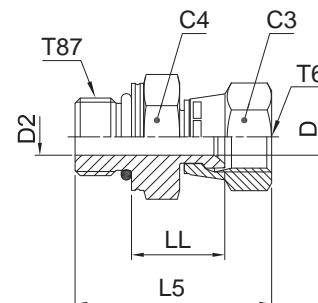

Tube O.D.		Thread Metric T87	Thread UN/UNF-2B T6	C4 mm	C3 mm	D mm	D2 mm	L5 mm	LL mm	Weight (steel) g/1 piece	Triple-Lok® Steel	Triple-Lok® Stainless Steel	PN (bar)	
mm	in.												S	SS
6	1/4	M 10×1.0	7/16-20	14	14	4.4	4.4	32	15.0	25	4M10F687OMXS	4M10F687OMXSS	500	350
6	1/4	M 12×1.5	7/16-20	17	14	4.4	6.0	35	15.0	30	4M12F687OMXS	4M12F687OMXSS	420	350
8	5/16	M 10×1.0	1/2-20	14	17	6.0	4.5	34	16.5	40	5M10F687OMXS	5M10F687OMXSS	420	350
8	5/16	M 12×1.5	1/2-20	17	17	6.0	6.0	37	16.5	64	5M12F687OMXS	5M12F687OMXSS	420	350
10	3/8	M 14×1.5	9/16-18	19	19	7.5	7.5	38	18.0	65	6M14F687OMXS	6M14F687OMXSS	350	350
10	3/8	M 16×1.5	9/16-18	22	19	7.5	9.0	40	19.0	75	6M16F687OMXS	6M16F687OMXSS	350	350
12	1/2	M 16×1.5	3/4-16	22	22	9.9	9.0	44	21.0	80	8M16F687OMXS	8M16F687OMXSS	350	350
12	1/2	M 18×1.5	3/4-16	24	22	9.9	11.0	45	21.0	90	8M18F687OMXS	8M18F687OMXSS	350	350
14, 15, 16	5/8	M 18×1.5	7/8-14	24	27	12.3	11.0	48	23.0	108	10M18F687OMXS	10M18F687OMXSS	350	350
14, 15, 16	5/8	M 22×1.5	7/8-14	27	27	12.3	14.0	49	23.0	115	10M22F687OMXS	10M22F687OMXSS	350	350
18, 20	3/4	M 22×1.5	1 1/16-12	27	32	15.5	14.0	52	24.5	183	12M22F687OMXS	12M22F687OMXSS	350	350
18, 20	3/4	M 27×2.0	1 1/16-12	32	32	15.5	18.0	55	24.5	197	12M27F687OMXS	12M27F687OMXSS	350	350
25	1	M 33×2.0	1 5/16-12	41	38	21.5	23.0	59	27.5	250	16M33F687OMXS	16M33F687OMXSS	250	280
28, 30, 32	1 1/4	M 42×2.0	1 5/8-12	50	50	27.5	30.0	63	31.0	500	20M42F687OMXS	20M42F687OMXSS	250	210
35, 38	1 1/2	M 48×2.0	1 7/8-12	55	60	33.0	36.0	72	33.0	688	24M48F687OMXS	24M48F687OMXSS	170	140

Steel, stainless steel and brass Triple-Lok® parts are delivered with NBR elastomeric seals as standard. For more details on other seal materials see page K92.

Order codes shown are part of our current manufacturing programme.

Imperial and metric parts may vary in hexagon dimensions.

$$\frac{\text{PN (bar)}}{10} = \text{PN (MPa)}$$

Do not create drawings from these dimensions, they are subject to change and ISO manufacturing allowances.

K

F65OMX Swivel male stud

Triple-Lok® 37° Flare female swivel end / Male UN/UNF thread – O-ring (ISO 11926)

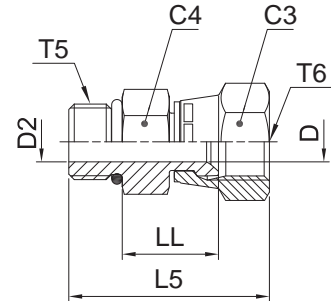

Tube O.D.		Thread UNF T5	Thread UN/UNF-2B T6	C4 mm	C3 mm	D mm	D2 mm	L5 mm	LL mm	Weight (steel) g/1 piece	Triple-Lok® Steel	PN (bar)
mm	in.											
6	1/4	7/16-20	7/16-20	14.0	14.0	4.4	4.4	33.0	15.0	27	4F65OMXS	500
8	5/16	1/2-20	1/2-20	17.0	17.0	6.0	6.0	35.0	17.0	30	5F65OMXS	420
10	3/8	9/16-18	9/16-18	17.0	19.0	7.5	7.5	38.0	18.0	35	6F65OMXS	350
12	1/2	3/4-16	3/4-16	22.2	22.0	9.9	9.9	41.5	19.0	64	8 F65OX-S	350
14, 15, 16	5/8	7/8-14	7/8-14	25.4	25.4	12.3	12.3	46.0	20.5	112	10 F65OX-S	350
18, 20	3/4	1 1/16-12	1 1/16-12	28.6	28.6	15.5	15.5	54.0	25.0	183	12 F65OX-S	350
25	1	1 5/16-12	1 5/16-12	38.0	38.0	21.4	21.4	58.0	27.0	234	16 F65OX-S	250
28, 30, 32	1 1/4	1 5/8-12	1 5/8-12	51.0	51.0	27.5	27.5	63.0	32.0	500	20 F65OX-S	250

Steel, stainless steel and brass Triple-Lok® parts are delivered with NBR elastomeric seals as standard. For more details on other seal materials see page K92.

Order codes shown are part of our current manufacturing programme.

Imperial and metric parts may vary in hexagon dimensions.

$$\frac{\text{PN (bar)}}{10} = \text{PN (MPa)}$$

Do not create drawings from these dimensions, they are subject to change and ISO manufacturing allowances.

F642EDMX Swivel male stud

Triple-Lok® 37° Flare female swivel end / Male BSPP thread – ED seal (ISO 1179)

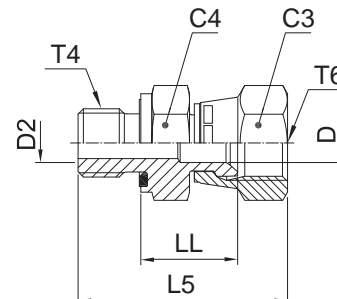

Tube O.D.		Thread BSPP T4	Thread UN/UNF-2B T6	C4 mm	C3 mm	D mm	D2 mm	L5 mm	LL mm	Weight (steel) g/1 piece	Triple-Lok® Steel	Triple-Lok® Stainless Steel	PN (bar)	
mm	in.												S	SS
6	1/4	1/8-28	7/16-20	14	14	4.4	4.4	32	15.0	30	4F642EDMXS	4F642EDMXSS	500	350
6	1/4	1/4-19	7/16-20	19	14	4.4	4.4	37	16.5	30	4-4F642EDMXS	4-4F642EDMXSS	420	350
8	5/16	1/8-28	1/2-20	14	17	6.0	4.0	34	17.0	28	5F642EDMXS	5F642EDMXSS	420	350
8	5/16	1/4-19	1/2-20	19	17	6.0	6.0	39	17.5	37	5-4F642EDMXS	5-4F642EDMXSS	420	350
10	3/8	1/4-19	9/16-18	19	19	7.5	6.0	40	18.5	41	6F642EDMXS	6F642EDMXSS	350	350
10	3/8	3/8-19	9/16-18	22	19	7.5	9.0	41	19.0	57	6-6F642EDMXS	6-6F642EDMXSS	350	350
12	1/2	3/8-19	3/4-16	22	22	9.9	9.0	44	21.0	62	8F642EDMXS	8F642EDMXSS	350	350
12	1/2	1/4-19	3/4-16	19	22	9.9	6.0	44	21.0	60	8-4F642EDMXS	8-4F642EDMXSS	350	350
12	1/2	1/2-14	3/4-16	27	22	9.9	14.0	48	23.0	75	8-8F642EDMXS	8-8F642EDMXSS	350	350
14, 15, 16	5/8	1/2-14	7/8-14	27	27	12.3	14.0	50	23.0	127	10F642EDMXS	10F642EDMXSS	350	350
14, 15, 16	5/8	3/8-19	7/8-14	22	27	12.3	9.0	44	21.0	84	10-6F642EDMXS	10-6F642EDMXSS	350	350
				36	32	12.3	12.3	49	23.0	169	10-12F642EDMXS	10-12F642EDMXSS	350	350
18, 20	3/4	3/4-14	1 1/16-12	32	32	15.5	18.0	55	24.5	183	12F642EDMXS	12F642EDMXSS	350	350
18, 20	3/4	1/2-14	1 1/16-12	27	32	15.5	14.0	53	24.5	170	12-8F642EDMXS	12-8F642EDMXSS	350	350
25	1	1-11	1 5/16-12	41	38	21.5	23.0	61	27.5	296	16F642EDMXS	16F642EDMXSS	250	250
25	1	3/4-14	1 5/16-12	32	38	21.5	18.0	59	27.5	254	16-12F642EDMXS	16-12F642EDMXSS	250	250
28, 30, 33	1 1/4	1 1/4-11	1 5/8-12	50	50	27.5	30.0	68	32.0	500	20F642EDMXS	20F642EDMXSS	250	210
28, 30, 32	1 1/4	1-11	1 5/8-12	41	50	27.5	23.0	70	36.5	440	20-16F642EDMXS	20-16F642EDMXSS	250	210
35, 38	1 1/2	1 1/2-11	1 7/8-12	55	60	33.0	36.0	80	36.0	739	24F642EDMXS	24F642EDMXSS	170	140

Steel, stainless steel and brass Triple-Lok® parts are delivered with NBR elastomeric seals as standard. For more details on other seal materials see page K92.

Order codes shown are part of our current manufacturing programme.

Imperial and metric parts may vary in hexagon dimensions.

$$\frac{\text{PN (bar)}}{10} = \text{PN (MPa)}$$

Do not create drawings from these dimensions, they are subject to change and ISO manufacturing allowances.

F64OMX Swivel male stud

Triple-Lok® 37° Flare female swivel end /
Male BSPP thread – O-ring + retainer ring (ISO 1179)

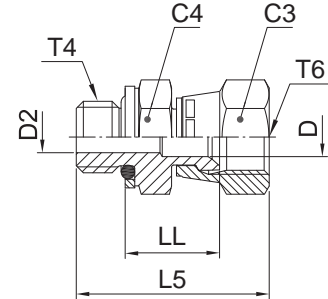

Tube O.D.		Thread BSPP T4	Thread UN/UNF-2B T6	C4 mm	C3 mm	D mm	D2 mm	L5 mm	LL mm	Weight (steel) g/1 piece	Triple-Lok® Steel	Triple-Lok® Stainless Steel	PN (bar)	
mm	in.												S	SS
6	1/4	1/8-28	7/16-20	17	14	4.4	4.4	32	17.0	30	4F64OMXS	4F64OMXSS	350	350
6	1/4	1/4-19	7/16-20	19	14	4.4	6.0	34	17.0	30	4-4F64OMXS	4-4F64OMXSS	350	350
8	5/16	1/8-28	1/2-20	17	17	6.0	4.0	32	17.0	28	5F64OMXS	5F64OMXSS	350	350
8	5/16	1/4-19	1/2-20	19	17	7.5	6.0	36	18.0	37	5-4F64OMXS	5-4F64OMXSS	350	350
10	3/8	1/4-19	9/16-18	19	19	7.5	6.0	37	18.0	41	6F64OMXS	6F64OMXSS	350	350
10	3/8	3/8-19	9/16-18	22	19	7.5	9.0	38	19.0	57	6-6F64OMXS	6-6F64OMXSS	350	350
12	1/2	3/8-19	3/4-16	22	22	9.9	9.0	41	21.0	62	8F64OMXS	8F64OMXSS	350	350
12	1/2	1/4-19	3/4-16	19	22	9.9	6.0	43	20.0	57	8-4F64OMXS	8-4F64OMXSS	350	350
12	1/2	1/2-14	3/4-16	30	22	9.9	14.0	46	23.0	75	8-8F64OMXS	8-8F64OMXSS	350	350
14, 15, 16	5/8	1/2-14	7/8-14	30	27	12.3	14.0	50	24.5	127	10F64OMXS	10F64OMXSS	350	350
14, 15, 16	5/8	3/8-19	7/8-14	22	27	12.3	9.0	44	22.5	84	10-6F64OMXS	10-6F64OMXSS	350	350
18, 20	3/4	3/4-14	1 1/16-12	36	32	15.5	18.0	52	23.5	183	12F64OMXS	12F64OMXSS	280	280
18, 20	3/4	1/2-14	1 1/16-12	30	32	15.5	14.0	50	21.5	169	12-8F64OMXS	12-8F64OMXSS	350	350
25	1	1-11	1 5/16-12	46	38	21.5	23.0	59	27.0	296	16F64OMXS	16F64OMXSS	250	250
25	1	3/4-14	1 5/16-12	36	38	21.5	18.0	54	26.0	253	16-12F64OMXS	16-12F64OMXSS	250	250
28, 30, 32	1 1/4	1 1/4-11	1 5/8-12	50	50	27.5	30.0	64	32.0	500	20F64OMXS	20F64OMXSS	250	175
28, 30, 32	1 1/4	1-11	1 5/8-12	46	50	27.5	23.0	63	31.0	420	20-16F64OMXS	20-16F64OMXSS	250	175
35, 38	1 1/2	1 1/2-11	1 7/8-12	55	60	33.0	36.0	73	36.0	739	24F64OMXS	24F64OMXSS	170	140

Steel, stainless steel and brass Triple-Lok® parts are delivered with NBR elastomeric seals as standard. For more details on other seal materials see page K92.

Order codes shown are part of our current manufacturing programme.

Imperial and metric parts may vary in hexagon dimensions.

$$\frac{PN \text{ (bar)}}{10} = PN \text{ (MPa)}$$

Do not create drawings from these dimensions, they are subject to change and ISO manufacturing allowances.

F682EDMX Swivel male stud

Triple-Lok® 37° Flare female swivel end / Male metric thread – ED seal (ISO 9974)

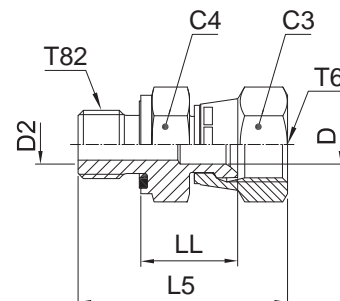

Tube O.D.		Thread Metric T82	Thread UN/UNF-2B T6	C4 mm	C3 mm	D mm	D2 mm	L5 mm	LL mm	Weight (steel) g/1 piece	Triple-Lok®		PN (bar)	
mm	in.										Steel	Stainless Steel	S	SS
6	1/4	M 10×1.0	7/16-20	14	14	4.4	4.0	32	15.0	28	4M10F682EDMXS	4M10F682EDMXSS	500	350
8	5/16	M 12×1.5	1/2-20	17	17	6.0	6.0	38	17.0	32	5M12F682EDMXS	5M12F682EDMXSS	420	350
10	3/8	M 14×1.5	9/16-18	19	19	7.5	7.0	40	18.0	42	6M14F682EDMXS	6M14F682EDMXSS	350	350
12	1/2	M 16×1.5	3/4-16	22	22	9.9	9.0	44	21.0	62	8M16F682EDMXS	8M16F682EDMXSS	350	350
12	1/2	M 18×1.5	3/4-16	24	22	9.9	11.0	44	21.0	70	8M18F682EDMXS	8M18F682EDMXSS	350	350
14, 15, 16	5/8	M 18×1.5	7/8-14	24	27	12.3	11.0	48	23.0	125	10M18F682EDMXS	10M18F682EDMXSS	350	350
14, 15, 16	5/8	M 22×1.5	7/8-14	27	27	12.3	14.0	50	23.0	155	10M22F682EDMXS	10M22F682EDMXSS	350	350
18, 20	3/4	M 22×1.5	1 1/16-12	27	32	15.5	14.0	52	24.5	160	12M22F682EDMXS	12M22F682EDMXSS	350	350
18, 20	3/4	M 27×2.0	1 1/16-12	32	32	15.5	15.5	55	24.5	172	12M27F682EDMXS	12M27F682EDMXSS	350	350
25	1	M 33×2.0	1 5/16-12	41	38	21.5	23.0	61	26.5	259	16M33F682EDMXS	16M33F682EDMXSS	250	250
28, 30, 32	1 1/4	M 42×2.0	1 5/8-12	50	50	27.5	30.0	68	32.0	484	20M42F682EDMXS	20M42F682EDMXSS	250	210

Steel, stainless steel and brass Triple-Lok® parts are delivered with NBR elastomeric seals as standard. For more details on other seal materials see page K92.

Order codes shown are part of our current manufacturing programme.

Imperial and metric parts may vary in hexagon dimensions.

$$\frac{\text{PN (bar)}}{10} = \text{PN (MPa)}$$

Do not create drawings from these dimensions, they are subject to change and ISO manufacturing allowances.



F68OMX Swivel male stud

Triple-Lok® 37° Flare female swivel end / Male metric thread O-ring + retaining ring

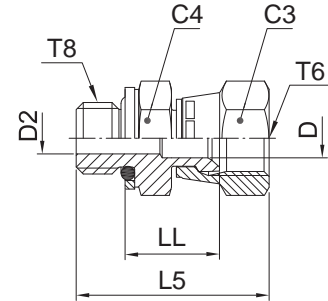

Tube O.D. mm	Tube O.D. in.	Thread Metric T8	Thread UN/UNF-2B T6	C4 mm	C3 mm	D mm	D2 mm	L5 mm	LL mm	Weight (steel) g/1 piece	Triple-Lok® Steel	PN (bar)
6	1/4	M 10×1.0	7/16-20	14	14	4.4	4.0	32	15.0	28	4M10F68OMXS	350
8	5/16	M 12×1.5	1/2-20	17	17	6.0	6.0	37	18.0	32	5M12F68OMXS	420
10	3/8	M 14×1.5	9/16-18	19	19	7.5	7.0	38	19.5	42	6M14F68OMXS	350
12	1/2	M 16×1.5	3/4-16	22	22	9.9	7.5	44	23.0	62	8M16F68OMXS	350
12	1/2	M 18×1.5	3/4-16	24	22	9.9	11.0	45	23.0	62	8M18F68OMXS	250
14, 15, 16	5/8	M 18×1.5	7/8-14	24	27	12.3	11.0	48	25.0	127	10M18F68OMXS	250
14, 15, 16	5/8	M 22×1.5	7/8-14	27	27	12.3	14.0	49	25.0	155	10M22F68OMXS	250
18, 20	3/4	M 27×2.0	1 1/16-12	32	32	15.5	15.5	55	26.0	172	12M27F68OMXS	210
25	1	M 33×2.0	1 5/16-12	41	38	21.5	23.0	57	29.0	259	16M33F68OMXS	210
28, 30, 32	1 1/4	M 42×2.0	1 5/8-12	50	50	27.5	30.0	63	33.0	484	20M42F68OMXS	210

Steel, stainless steel and brass Triple-Lok® parts are delivered with NBR elastomeric seals as standard. For more details on other seal materials see page K92.

Order codes shown are part of our current manufacturing programme.

Imperial and metric parts may vary in hexagon dimensions.

$$\frac{\text{PN (bar)}}{10} = \text{PN (MPa)}$$

Do not create drawings from these dimensions, they are subject to change and ISO manufacturing allowances.

F6MX Swivel male stud

Triple-Lok® 37° Flare female swivel end / Male NPT* thread (SAE 476)

*Stainless Steel = NPT to prevent galling

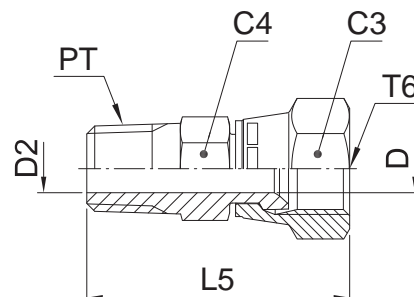

Tube O.D.		Thread NPT/NPTF PT	Thread UN/UNF-2B T6	C4 mm	C3 mm	D mm	D2 mm	L5 mm	Weight (steel) g/1 piece	Triple-Lok® Steel	Triple-Lok® Stainless Steel	PN (bar)	
mm	in.											S	SS
6	1/4	1/8-27	7/16-20	14.3	14.3	4.4	4.4	31	18	4 F6X-S	4F6MXSS	420	350
6	1/4	1/4-18	7/16-20	14.3	14.3	4.4	4.4	39	19	4-4 F6X-S	4-4F6MXSS	420	350
8	5/16	1/8-27	1/2-20	14.0	17.0	6.0	5.0	35	26	5F6MXS	5F6MXSS	420	350
8	5/16	1/4-18	1/2-20	16.0	16.0	6.0	6.0	40	37	5-4 F6X-S	5-4F6MXSS	420	350
10	3/8	1/4-18	9/16-18	17.5	17.5	7.1	7.1	40	30	6 F6X-S	6F6MXSS	350	350
10	3/8	3/8-18	9/16-18	19.0	17.5	7.5	7.5	43	48	6-6 F6X-S	6-6F6MXSS	350	350
12	1/2	3/8-18	3/4-16	22.2	22.2	9.9	9.9	44	50	8 F6X-S	8F6MXSS	350	350
12	1/2	1/4-18	3/4-16	19.0	22.0	9.9	7.0	44	46	8-4F6MXS	8-4F6MXSS	350	350
12	1/2	1/2-14	3/4-16	22.2	22.2	9.9	9.9	49	69	8-8 F6X-S	8-8F6MXSS	350	350
14, 15, 16	5/8	1/2-14	7/8-14	25.4	25.4	12.3	12.3	52	75	10 F6X-S	10F6MXSS	350	350
14, 15, 16	5/8	3/8-18	7/8-14	25.4	25.4	10.3	10.3	47	67	10-6 F6X-S	10-6F6MXSS	350	350
18, 20	3/4	3/4-14	1 1/16-12	31.8	31.8	15.5	15.5	55	125	12 F6X-S	12F6MXSS	350	350
18, 20	3/4	1/2-14	1 1/16-12	31.8	31.8	15.5	13.5	55	124	12-8 F6X-S	12-8F6MXSS	350	350
25	1	1-11.5	1 5/16-12	38.0	38.3	21.4	21.4	64	204	16 F6X-S	16F6MXSS	250	250
25	1	3/4-14	1 5/16-12	38.0	38.3	21.4	18.3	59	169	16-12 F6X-S	16-12F6MXSS	250	250
28, 30, 32	1 1/4	1 1/4-11.5	1 5/8-12	50.8	50.8	27.4	27.4	70	496	20 F6X-S	20F6MXSS	210	210
35, 38	1 1/2	1 1/2-11.5	1 7/8-12	57.2	57.2	33.3	33.3	77	750	24 F6X-S	24F6MXSS	170	170

Order codes shown are part of our current manufacturing programme.

Imperial and metric parts may vary in hexagon dimensions.

$$\frac{\text{PN (bar)}}{10} = \text{PN (MPa)}$$

Do not create drawings from these dimensions, they are subject to change and ISO manufacturing allowances.

K

F63MX Swivel male stud

Triple-Lok® 37° Flare female swivel end / Male BSPT thread (ISO 7)

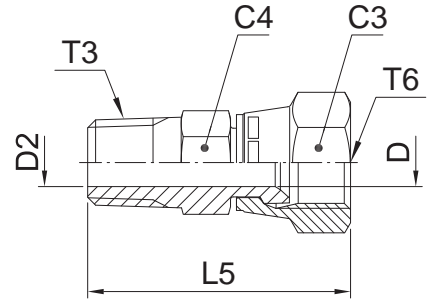

Tube O.D.		Thread BSPT T3	Thread UN/UNF-2B T6	C4 mm	C3 mm	D mm	D2 mm	L5 mm	Weight (steel) g/1 piece	Triple-Lok® Steel	Triple-Lok® Stainless Steel	PN (bar)	
mm	in.											S	SS
6	1/4	1/8-28	7/16-20	13	14	4.4	5.0	33	18	4F63MXS	4F63MXSS	315	315
6	1/4	1/4-19	7/16-20	14	14	4.4	7.0	38	19	4-4F63MXS	4-4F63MXSS	315	315
8	5/16	1/4-19	1/2-20	14	17	6.0	7.0	40	37	5-4F63MXS	5-4F63MXSS	315	315
10	3/8	1/4-19	9/16-18	14	19	7.5	7.0	41	30	6F63MXS	6F63MXSS	315	315
10	3/8	3/8-19	9/16-18	19	19	7.5	10.0	41	48	6-6F63MXS	6-6F63MXSS	315	315
12	1/2	3/8-19	3/4-16	19	22	9.9	9.9	44	50	8F63MXS	8F63MXSS	315	315
12	1/2	1/4-19	3/4-16	19	22	9.9	7.0	44	46	8-4F63MXS	8-4F63MXSS	315	315
14, 15, 16	5/8	1/2-14	7/8-14	22	27	12.3	13.5	53	75	10F63MXS	10F63MXSS	315	315
14, 15, 16	5/8	3/8-19	7/8-14	22	27	12.3	10.0	48	67	10-6F63MXS	10-6F63MXSS	315	315
18, 20	3/4	3/4-14	1 1/16-12	30	32	15.5	18.0	56	125	12F63MXS	12F63MXSS	160	160
18, 20	3/4	1/2-14	1 1/16-12	27	32	15.5	13.5	56	120	12-8F63MXS	12-8F63MXSS	315	315
25	1	1-11	1 5/16-12	36	38	21.5	24.0	64	204	16F63MXS	16F63MXSS	160	160
25	1	3/4-14	1 5/16-12	32	38	21.5	18.0	59	165	16-12F63MXS	16-12F63MXSS	160	160
28, 30, 32	1 1/4	1 1/4-11	1 5/8-12	46	50	27.5	32.0	70	496	20F63MXS	20F63MXSS	160	160

Order codes shown are part of our current manufacturing programme.

Imperial and metric parts may vary in hexagon dimensions.

$$\frac{\text{PN (bar)}}{10} = \text{PN (MPa)}$$

Do not create drawings from these dimensions, they are subject to change and ISO manufacturing allowances.

C87OMX Male stud elbow

Triple-Lok® 37° Flare end /
Adjustable metric thread – O-ring (ISO 6149)

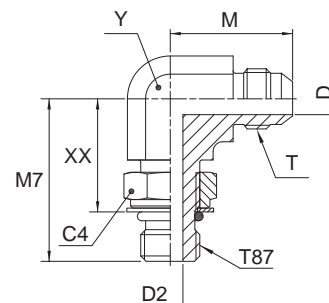

Tube O.D.		Thread Metric T87	Thread UN/UNF-2A T	C4 mm	D mm	D2 mm	M mm	M7 mm	XX mm	Y mm	Weight (steel) g/1 piece	Triple-Lok®		PN (bar)	
mm	in.											Steel	Stainless Steel	S	SS
6	1/4	M 10×1.0	7/16-20	14	4.4	4.5	23	27	19	11	17	4M10C87OMXS	4M10C87OMXSS	420	350
6	1/4	M 12×1.5	7/16-20	17	4.4	6.0	24	31	19	13	20	4M12C87OMXS	4M12C87OMXSS	420	350
8	5/16	M 10×1.0	1/2-20	14	6.0	4.5	24	26	17	13	22	5M10C87OMXS	5M10C87OMXSS	420	350
8	5/16	M 12×1.5	1/2-20	17	6.0	6.0	24	31	19	13	25	5M12C87OMXS	5M12C87OMXSS	420	350
10	3/8	M 14×1.5	9/16-18	19	7.5	7.5	27	34	22	14	31	6M14C87OMXS	6M14C87OMXSS	420	350
10	3/8	M 16×1.5	9/16-18	22	7.5	9.0	29	38	26	19	55	6M16C87OMXS	6M16C87OMXSS	350	350
10	3/8	M 16×1.5	3/4-16	22	9.9	9.0	32	38	26	19	65	8M16C87OMXS	8M16C87OMXSS	350	350
12	1/2	M 18×1.5	3/4-16	24	9.9	11.0	32	38	25	19	66	8M18C87OMXS	8M18C87OMXSS	350	350
14, 15, 16	5/8	M 18×1.5	7/8-14	24	12.3	11.0	37	42	29	22	99	10M18C87OMXS	10M18C87OMXSS	350	350
14, 15, 16	5/8	M 22×1.5	7/8-14	27	12.3	14.0	37	43	29	22	99	10M22C87OMXS	10M22C87OMXSS	350	350
18, 20	3/4	M 22×1.5	1 1/16-12	27	15.5	14.0	42	45	32	27	164	12M22C87OMXS	12M22C87OMXSS	350	350
18, 20	3/4	M 27×2.0	1 1/16-12	32	15.5	18.0	42	51	35	27	173	12M27C87OMXS	12M27C87OMXSS	350	350
25	1	M 27×2.0	1 5/16-12	32	21.5	18.0	46	53	37	33	287	16M27C87OMXS	16M27C87OMXSS	280	280
25	1	M 33×2.0	1 5/16-12	41	21.5	23.0	46	53	37	33	287	16M33C87OMXS	16M33C87OMXSS	280	280
28, 30, 32	1 1/4	M 42×2.0	1 5/8-12	50	27.5	30.0	52	58	42	41	575	20M42C87OMXS	20M42C87OMXSS	210	210
35, 38	1 1/2	M 48×2.0	1 7/8-12	55	33.0	36.0	59	64	46	48	874	24M48C87OMXS	24M48C87OMXSS	140	140

Steel, stainless steel and brass Triple-Lok® parts are delivered with NBR elastomeric seals as standard. For more details on other seal materials see page K92.

Order codes shown are part of our current manufacturing programme.

Imperial and metric parts may vary in hexagon dimensions.

$$\frac{\text{PN (bar)}}{10} = \text{PN (MPa)}$$

Do not create drawings from these dimensions, they are subject to change and ISO manufacturing allowances.

K

C50MX Male stud elbow

Triple-Lok® 37° Flare end /
Adjustable UN/UNF thread – O-ring (ISO 11926)
SAE 070220 MS51527

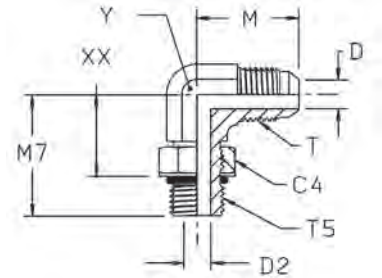

Tube O.D.		Thread UN/UNF-2A T5	Thread UN/UNF-2A T	C4 mm	D mm	D2 mm	M mm	M7 mm	XX mm	Y mm	Weight (steel) g/1 piece	Triple-Lok® Steel	Triple-Lok® Stainless Steel	PN (bar)	
mm	in.													S	SS
6	1/8	5/16-24	5/16-24	11.1	1.5	1.5	20	24	15	11	25	2 C50X-S		350	—
	3/16	3/8-24	3/8-24	12.7	3.2	3.2	21	24	15	11	30	3 C50X-S		350	—
	1/4	7/16-20	7/16-20	14.3	4.4	4.5	23	26	16	11	37	4C50MXS	4C50MXSS	420	350
	1/4	9/16-18	7/16-20	17.5	4.4	7.5	27	32	20	14	43	4-6 C50X-S	4-6C50MXSS	420	350
8	5/16	1/2-20	1/2-20	16.0	6.0	6.0	24	29	18	13	47	5C50MXS	5C50MXSS	420	350
8	5/16	7/16-20	1/2-20	14.3	6.0	4.4	24	29	18	14	55	5-4 C50X-S	5-4C50MXSS	420	350
8	5/16	9/16-18	1/2-20	17.5	6.0	7.5	27	32	20	14	62	5-6 C50X-S	5-6C50MXSS	420	350
10	3/8	9/16-18	9/16-18	17.5	7.5	7.5	27	32	20	14	63	6C50MXS	6C50MXSS	420	350
10	3/8	7/16-20	9/16-18	14.3	7.5	4.4	27	30	20	14	99	6-4 C50X-S	6-4C50MXSS	420	350
10	3/8	1/2-20	9/16-18	16.0	7.5	6.0	27	30	19	14	99	6-5 C50X-S	6-5C50MXSS	420	350
10	3/8	3/4-16	9/16-18	22.2	7.5	10.0	29	37	24	19	125	6-8 C50X-S	6-8C50MXSS	420	350
10	3/8	7/8-14	9/16-18	25.4	7.5	12.5	31	43	28	22	145	6-10 C50X-S	6-10C50MXSS	350	350
12	1/2	3/4-16	3/4-16	22.2	9.9	10.0	32	37	24	19	160	8C50MXS	8C50MXSS	420	350
12	1/2	7/16-20	3/4-16	14.3	9.9	4.4	32	32	21	19	150	8-4 C50X-S	8-4C50MXSS	420	350
12	1/2	9/16-18	3/4-16	17.5	9.9	7.5	32	34	22	19	130	8-6 C50X-S	8-6C50MXSS	420	350
12	1/2	7/8-14	3/4-16	27.0	9.9	12.5	34	43	28	22	180	8-10C50MXS	8-10C50MXSS	350	350
12	1/2	1 1/16-12	3/4-16	31.8	9.9	15.5	36	49	32	27	210	8-12 C50X-S	8-12C50MXSS	350	350
14, 15, 16	5/8	7/8-14	7/8-14	27.0	12.3	12.5	37	43	28	22	186	10C50MXS	10C50MXSS	350	350
14, 15, 16	5/8	9/16-18	7/8-14	17.5	12.3	7.5	37	36	24	22	130	10-6 C50X-S	10-6C50MXSS	350	350
14, 15, 16	5/8	3/4-16	7/8-14	22.2	12.3	10.0	37	39	26	22	157	10-8 C50X-S	10-8C50MXSS	350	350
14, 15, 16	5/8	1 1/16-12	7/8-14	31.8	12.3	15.5	39	49	32	27	331	10-12 C50X-S	10-12C50MXSS	350	350
14, 15, 16	5/8	1 5/16-12	7/8-14	38.0	12.3	21.4	42	52	35	33	400	10-16 C50X-S	10-16C50MXSS	280	280
18, 20	3/4	1 1/16-12	1 1/16-12	32.0	15.5	15.5	42	49	32	27	301	12C50MXS	12C50MXSS	350	350
18, 20	3/4	3/4-16	1 1/16-12	22.2	15.5	10.0	42	41	28	27	297	12-8 C50X-S	12-8C50MXSS	350	350
18, 20	3/4	7/8-14	1 1/16-12	27.0	15.5	12.5	42	45	30	27	297	12-10C50MXS	12-10C50MXSS	350	350
18, 20	3/4	1 5/16-12	1 1/16-12	38.0	15.5	21.4	45	52	35	33	421	12-16 C50X-S	12-16C50MXSS	280	280
22	7/8	1 3/16-12	1 3/16-12	35.0	18.3	18.0	46	51	34	33	417	14 C50X-S		280	—
25	1	1 5/16-12	1 5/16-12	41.0	21.5	21.5	46	52	35	33	426	16C50MXS	16C50MXSS	280	280
25	1	1 1/16-12	1 5/16-12	31.8	21.5	15.5	46	52	35	33	418	16-12 C50X-S	16-12C50MXSS	280	280
25	1	1 5/8-12	1 5/16-12	47.6	21.5	27.4	51	57	40	41	546	16-20 C50X-S	16-20C50MXSS	280	210
28, 30, 32	1 1/4	1 5/8-12	1 5/8-12	47.6	27.4	27.4	52	57	40	41	674	20 C50X-S	20C50MXSS	280	210
28, 30, 32	1 1/4	1 5/16-12	1 5/8-12	38.0	27.4	21.5	52	57	40	41	650	20-16 C50X-S	20-16C50MXSS	280	280
28, 30, 32	1 1/4	1 7/8-12	1 5/8-12	54.0	27.4	33.4	56	61	44	48	920	20-24 C50X-S	20-24C50MXSS	210	210
35, 38	1 1/2	1 7/8-12	1 7/8-12	54.0	33.4	33.4	59	61	44	48	917	24 C50X-S	24C50MXSS	210	140
35, 38	1 1/2	1 5/8-12	1 7/8-12	47.6	33.4	27.4	59	61	44	48	920	24-20 C50X-S	24-20C50MXSS	210	140

Steel, stainless steel and brass Triple-Lok® parts are delivered with NBR elastomeric seals as standard. For more details on other seal materials see page K92.

Order codes shown are part of our current manufacturing programme.

Imperial and metric parts may vary in hexagon dimensions.

$$\frac{\text{PN (bar)}}{10} = \text{PN (MPa)}$$

Do not create drawings from these dimensions, they are subject to change and ISO manufacturing allowances.

CC50X Extended male stud elbow

Triple-Lok® 37° Flare end / Male UNF thread – O-ring (ISO 11926)

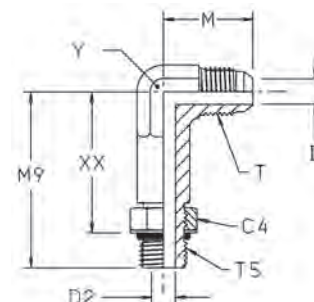

Tube O.D. mm	in.	Thread UN/UNF-2A T5	Thread UN/UNF-2A T	C4 mm	D mm	D2 mm	M mm	M9 mm	XX mm	Y mm	Weight (steel) g/1 piece	Triple-Lok® Steel	PN (bar)
6	1/4	7/16-20	7/16-20	14.3	4.4	4.5	23	44	33	14	44	4 CC50X-S	420
10	3/8	9/16-18	9/16-18	17.5	7.5	7.5	27	53	41	14	51	6 CC50X-S	420
12	1/2	3/4-16	3/4-16	22.2	9.9	9.9	32	64	50	22	146	8 CC50X-S	420
14, 15, 16	5/8	7/8-14	7/8-14	25.4	12.3	12.3	37	73	58	22	169	10 CC50X-S	350
18, 20	3/4	1 1/16-12	1 1/16-12	32.0	15.5	15.5	42	85	67	37	291	12 CC50X-S	350
25	1	1 5/16-12	1 5/16-12	38.0	21.5	21.5	46	95	78	33	481	16 CC50X-S	280

Steel, stainless steel and brass Triple-Lok® parts are delivered with NBR elastomeric seals as standard. For more details on other seal materials see page K92.
Order codes shown are part of our current manufacturing programme.

Imperial and metric parts may vary in hexagon dimensions.

$$\frac{\text{PN (bar)}}{10} = \text{PN (MPa)}$$

Do not create drawings from these dimensions, they are subject to change and ISO manufacturing allowances.

C4OMX Male stud elbow

Triple-Lok® 37° Flare end / Adjustable BSPP thread O-ring + retaining ring (ISO 1179)

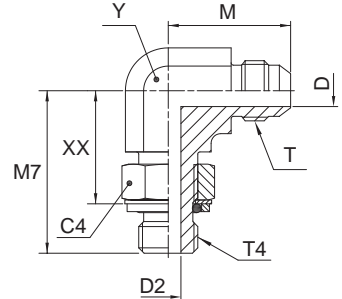

Tube O.D. mm	Tube O.D. in.	Thread BSPP T4	Thread UN/UNF-2A T	C4 mm	D mm	D2 mm	M mm	M7 mm	XX mm	Y mm	Weight (steel) g/1 piece	Triple-Lok®		PN (bar)	
												Steel	Stainless Steel	S	SS
6	1/4	1/8-28	7/16-20	14	4.4	4.4	23	27	19	11	37	4C4OMXS	4C4OMXSS	250	250
6	1/4	1/4-19	7/16-20	19	4.4	7.5	27	32	21	14	43	4-4C4OMXS	4-4C4OMXSS	250	200
6	1/4	3/8-19	7/16-20	22	4.4	9.9	29	37	26	19	50	4-6C4OMXS	4-6C4OMXSS	250	200
8	5/16	1/8-28	1/2-20	14	6.0	4.4	24	27	19	13	47	5C4OMXS	5C4OMXSS	250	250
8	5/16	1/4-19	1/2-20	19	6.0	7.5	27	32	21	14	55	5-4C4OMXS	5-4C4OMXSS	250	200
8	5/16	3/8-19	1/2-20	22	6.0	9.9	29	37	26	19	57	5-6C4OMXS	5-6C4OMXSS	250	200
10	3/8	1/4-19	9/16-18	19	7.5	7.5	27	32	21	14	61	6C4OMXS	6C4OMXSS	250	200
10	3/8	1/8-28	9/16-18	14	7.5	4.4	27	28	19	14	52	6-2C4OMXS	6-2C4OMXSS	250	200
10	3/8	3/8-19	9/16-18	22	7.5	9.9	29	37	26	19	95	6-6C4OMXS	6-6C4OMXSS	250	200
10	3/8	1/2-14	9/16-18	27	7.5	12.3	31	43	29	22	80	6-8C4OMXS	6-8C4OMXSS	250	200
12	1/2	3/8-19	3/4-16	22	9.9	9.9	32	37	27	19	102	8C4OMXS	8C4OMXSS	250	200
12	1/2	1/4-19	3/4-16	19	9.9	7.5	32	37	26	19	91	8-4C4OMXS	8-4C4OMXSS	250	200
12	1/2	1/2-14	3/4-16	27	9.9	12.3	34	43	29	22	155	8-8C4OMXS	8-8C4OMXSS	250	200
12	1/2	3/4-14	3/4-16	36	9.9	15.5	36	50	35	27	205	8-12C4OMXS	8-12C4OMXSS	250	200
14, 15, 16	5/8	1/2-14	7/8-14	27	12.3	12.3	37	43	29	22	164	10C4OMXS	10C4OMXSS	250	200
14, 15, 16	5/8	3/8-19	7/8-14	22	12.3	9.9	37	36	25	22	190	10-6C4OMXS	10-6C4OMXSS	250	200
14, 15, 16	5/8	3/4-14	7/8-14	36	12.3	15.5	39	50	35	27	217	10-12C4OMXS	10-12C4OMXSS	250	200
18, 20	3/4	3/4-14	1 1/16-12	36	15.5	15.5	42	50	35	27	295	12C4OMXS	12C4OMXSS	250	200
18, 20	3/4	1/2-14	1 1/16-12	27	15.5	12.3	42	50	35	27	245	12-8C4OMXS	12-8C4OMXSS	250	200
18, 20	3/4	1-11	1 1/16-12	41	15.5	21.5	45	52	35	33	317	12-16C4OMXS	12-16C4OMXSS	250	200
25	1	1-11	1 5/16-12	41	21.5	21.5	46	52	36	33	425	16C4OMXS	16C4OMXSS	250	200
25	1	3/4-14	1 5/16-12	36	21.5	15.5	46	47	33	33	405	16-12C4OMXS	16-12C4OMXSS	250	200
28, 30, 32	1 1/4	1 1/4-11	1 5/8-12	50	27.5	27.5	52	57	41	41	697	20C4OMXS	20C4OMXSS	210	160
28, 30, 32	1 1/4	1-11	1 5/8-12	41	21.5	27.5	52	57	41	41	650	20-16C4OMXS	20-16C4OMXSS	250	160
35, 38	1 1/2	1 1/2-11	1 7/8-12	55	33.0	33.0	59	61	45	48	953	24C4OMXS	24C4OMXSS	140	140
35, 38	1 1/2	1 1/4-11	1 7/8-12	50	33.0	27.5	59	61	45	48	964	24-20C4OMXS	24-20C4OMXSS	210	140

Steel, stainless steel and brass Triple-Lok® parts are delivered with NBR elastomeric seals as standard. For more details on other seal materials see page K92.

Order codes shown are part of our current manufacturing programme.

Imperial and metric parts may vary in hexagon dimensions.

$$\frac{PN \text{ (bar)}}{10} = PN \text{ (MPa)}$$

Do not create drawings from these dimensions, they are subject to change and ISO manufacturing allowances.

C8OMX Male stud elbow

Triple-Lok® 37° Flare end / Male metric thread – O-ring + retainer ring

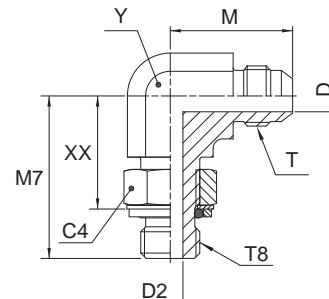

Tube O.D.		Thread Metric T8	Thread UN/UNF-2A T	C4 mm	D mm	D2 mm	M mm	M7 mm	XX mm	Y mm	Weight (steel) g/1 piece	Triple-Lok® Steel	PN (bar)
mm	in.												
6	1/4	M 10×1.0	7/16-20	14	4.4	4.5	23	27.0	18	11	23	4M10C8OMXS	250
6	1/4	M 12×1.5	7/16-20	17	4.4	6.0	24	30.5	19	13	28	4M12C8OMXS	250
8	5/16	M 10×1.0	1/2-20	14	6.0	4.5	24	26.0	17	13	29	5M10C8OMXS	250
8	5/16	M 12×1.5	1/2-20	17	6.0	6.0	24	31.0	19	13	29	5M12C8OMXS	250
8	5/16	M 12×1.5	9/16-18	17	7.5	6.0	27	34.0	22	14	48	6M12C8OMXS	250
10	3/8	M 14×1.5	9/16-18	17	7.5	7.5	27	34.0	22	14	36	6M14C8OMXS	250
10	3/8	M 16×1.5	9/16-18	19	7.5	9.0	29	38.0	27	19	74	6M16C8OMXS	250
10	3/8	M 18×1.5	9/16-18	22	7.5	11.0	29	38.0	26	19	100	6M18C8OMXS	250
12	1/2	M 16×1.5	3/4-16	19	9.9	9.0	32	38.0	27	19	77	8M16C8OMXS	250
12	1/2	M 18×1.5	3/4-16	22	9.9	11.0	32	38.0	26	19	78	8M18C8OMXS	250
12	1/2	M 22×1.5	3/4-16	27	9.9	14.0	34	43.0	31	22	95	8M22C8OMXS	250
14, 15, 16	5/8	M 18×1.5	7/8-14	22	12.3	11.0	37	42.0	31	22	104	10M18C8OMXS	250
14, 15, 16	5/8	M 22×1.5	7/8-14	27	12.3	14.0	37	43.0	31	22	119	10M22C8OMXS	250
18, 20	3/4	M 22×1.5	1 1/16-12	27	15.5	14.0	42	45.0	34	27	198	12M22C8OMXS	250
18, 20	3/4	M 27×2.0	1 1/16-12	32	15.5	18.0	42	51.0	38	27	208	12M27C8OMXS	175
25	1	M 33×2.0	1 5/16-12	38	21.5	23.0	46	53.0	40	33	333	16M33C8OMXS	140
28, 30, 32	1 1/4	M 42×2.0	1 5/8-12	50	27.5	30.0	52	58.0	45	41	575	20M42C8OMXS	140
35, 38	1 1/2	M 48×2.0	1 7/8-12	55	33.0	36.0	59	64.0	49	48	872	24M48C8OMXS	140

Steel, stainless steel and brass Triple-Lok® parts are delivered with NBR elastomeric seals as standard. For more details on other seal materials see page K92.

Order codes shown are part of our current manufacturing programme.

Imperial and metric parts may vary in hexagon dimensions.

$$\frac{\text{PN (bar)}}{10} = \text{PN (MPa)}$$

Do not create drawings from these dimensions, they are subject to change and ISO manufacturing allowances.

CMTX Male stud elbow

Triple-Lok® 37° Flare end / Male NPTF* thread (SAE 476)
SAE 070202 MS51504

*Stainless Steel = NPT to prevent galling

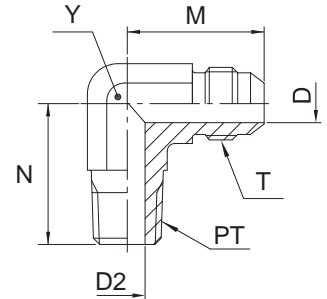

Tube O.D.	Thread NPT/NPTF PT	Thread UN/UNF-2A T	D mm	D2 mm	M mm	N mm	Y mm	Weight (steel) g/1 piece	Triple-Lok® Steel	Triple-Lok® Stainless Steel	PN (bar)		
											mm	in.	S
6	1/8	1/8-27	1.6	4.8	20	18	11.0	12	2 CTX-S		420	—	
	3/16	1/8-27	3.2	4.8	21	18	11.0	15	3 CTX-S		420	—	
	1/4	1/8-27	4.4	5.0	23	20	11.0	23	4CMTXS	4CMTXSS	420	350	
	1/4	1/4-18	7/16-20	4.4	7.0	27	28	14.0	42	4-4 CTX-S	4-4CMTXSS	420	350
	1/4	3/8-18	7/16-20	4.4	10.3	28	31	19.0	26	4-6 CTX-S	4-6CMTXSS	420	350
6	1/4	1/2-14	4.4	13.5	31	37	22.0	30	4-8 CTX-S	4-8CMTXSS	420	350	
8	5/16	1/8-27	6.0	4.8	24	20	14.0	29	5 CTX-S	5CMTXSS	420	350	
8	5/16	1/4-18	6.0	7.2	27	28	14.0	42	5-4 CTX-S	5-4CMTXSS	420	350	
8	5/16	3/8-18	6.0	10.3	29	31	19.0	45	5-6 CTX-S	5-6CMTXSS	420	350	
10	3/8	1/4-18	7.5	7.0	27	28	14.0	45	6CMTXS	6CMTXSS	420	350	
10	3/8	1/8-27	7.5	4.8	27	23	14.0	55	6-2 CTX-S	6-2CMTXSS	420	350	
10	3/8	3/8-18	7.5	10.0	29	31	19.0	76	6-6CMTXS	6-6CMTXSS	420	350	
10	3/8	1/2-14	7.5	13.5	31	37	22.0	117	6-8CMTXS	6-8CMTXSS	420	350	
12	1/2	3/8-18	9.9	10.0	32	31	19.0	86	8CMTXS	8CMTXSS	420	350	
12	1/2	1/4-18	9.9	7.0	32	31	19.0	82	8-4CMTXS	8-4CMTXSS	420	350	
12	1/2	1/2-14	9.9	13.5	34	37	22.0	125	8-8CMTXS	8-8CMTXSS	420	350	
12	1/2	3/4-14	9.9	18.3	36	40	27.0	190	8-12 CTX-S	8-12CMTXSS	280	280	
14, 15,16	5/8	1/2-14	12.3	13.5	37	37	22.0	129	10CMTXS	10CMTXSS	350	350	
14, 15,16	5/8	3/8-18	12.3	10.3	37	33	22.0	127	10-6 CTX-S	10-6CMTXSS	350	350	
14, 15,16	5/8	3/4-14	12.3	18.0	39	40	27.0	192	10-12CMTXS	10-12CMTXSS	280	280	
18, 20	3/4	3/4-14	15.5	18.3	42	40	27.0	198	12 CTX-S	12CMTXSS	280	280	
18, 20	3/4	1/2-14	15.5	13.5	42	40	27.0	204	12-8 CTX-S	12-8CMTXSS	350	350	
18, 20	3/4	1-11.5	15.5	23.8	45	50	33.0	318	12-16CMTXS	12-16CMTXSS	210	210	
22	7/8	3/4-14	18.3	18.3	46	48	33.4	260	14 CTX-S	14CMTXSS	280	245	
25	1	1-11.5	21.5	23.8	46	50	33.4	328	16 CTX-S	16CMTXSS	210	210	
25	1	3/4-14	21.5	18.3	46	45	33.4	318	16-12 CTX-S	16-12CMTXSS	280	280	
25	1	1 1/4-11.5	21.5	31.8	51	61	41.0	477	16-20 CTX-S	16-20CMTXSS	170	170	
28, 30, 32	1 1/4	1 1/4-11.5	27.4	31.8	52	61	41.0	549	20 CTX-S	20CMTXSS	170	170	
28, 30, 32	1 1/4	1-11.5	27.4	24.0	52	60	41.0	536	20-16CMTXS	20-16CMTXSS	210	210	
28, 30, 32	1 1/4	1 1/2-11.5	27.4	38.0	56	67	48.0	630	20-24 CTX-S	20-24CMTXSS	170	140	
35, 38	1 1/2	1 1/2-11.5	33.3	38.0	59	67	48.0	747	24 CTX-S	24CMTXSS	170	140	
35, 38	1 1/2	1 1/4-11.5	33.3	31.8	59	57	48.0	715	24-20 CTX-S	24-20CMTXSS	170	140	
	2	2-11.5	45.2	49.2	78	76	64.0	1644	32 CTX-S		140	—	
	2	1 1/2-11.5	45.2	38.0	78	75	64.0	1450	32-24 CTX-S		140	—	

Order codes shown are part of our current manufacturing programme.

Imperial and metric parts may vary in hexagon dimensions.

$$\frac{\text{PN (bar)}}{10} = \text{PN (MPa)}$$

Do not create drawings from these dimensions, they are subject to change and ISO manufacturing allowances.

CCTX Extended male stud elbow

Triple-Lok® 37° Flare end / Male NPTF* thread (SAE 476)

SAE 070202 MS51504

*Stainless Steel = NPT to prevent galling

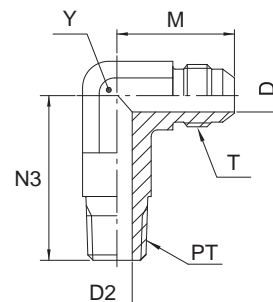

Tube O.D.		Thread NPT/NPTF PT	Thread UN/UNF-2A T	D mm	D2 mm	M mm	N3 mm	Y mm	Weight (steel) g/1 piece	Triple-Lok® Steel	Triple-Lok® Stainless Steel	PN (bar)	
mm	in.											S	SS
6	1/4	1/8-27	7/16-20	4.4	4.8	23	30	11.0	28	4 CCTX-S	4 CCTX-SS	420	350
6	1/4	1/4-18	7/16-20	4.4	7.0	27	40	14.0	28	4-4 CCTX-S	4-4 CCTX-SS	420	350
8	5/16	1/8-27	1/2-20	6.0	4.8	24	30	14.0	35	5 CCTX-S	5 CCTX-SS	420	350
10	3/8	1/4-18	9/16-18	7.5	7.2	27	40	14.0	58	6 CCTX-S	6 CCTX-SS	420	350
10	3/8	3/8-18	9/16-18	7.5	10.3	29	46	19.0	58	6-6 CCTX-S	6-6 CCTX-SS	420	350
12	1/2	3/8-18	3/4-16	9.9	10.3	32	46	19.0	111	8 CCTX-S	8 CCTX-SS	420	350
12	1/2	1/2-14	3/4-16	9.9	13.5	34	55	22.0	136	8-8 CCTX-S	8-8 CCTX-SS	420	350
14, 15, 16	5/8	1/2-14	7/8-14	12.3	13.5	37	55	22.0	183	10 CCTX-S	10 CCTX-SS	350	350
18, 20	3/4	3/4-14	1 1/16-12	15.5	18.3	42	62	26.5	253	12 CCTX-S	12 CCTX-SS	280	280
25	1	1-11.5	1 5/16-12	21.4	23.8	46	76	33.0	435	16 CCTX-S	16 CCTX-SS	210	210
28, 30, 32	1 1/4	1 1/4-11.5	1 5/8-12	27.4	31.8	52	94	41.0	1021	20 CCTX-S	20 CCTX-SS	170	170

Order codes shown are part of our current manufacturing programme.

Imperial and metric parts may vary in hexagon dimensions.

$$\frac{\text{PN (bar)}}{10} = \text{PN (MPa)}$$

Do not create drawings from these dimensions, they are subject to change and ISO manufacturing allowances.

K

CCCTX Extended male stud elbow

Triple-Lok® 37° Flare end / Male NPTF* thread (SAE 476)
SAE 071602

*Stainless Steel = NPT to prevent galling

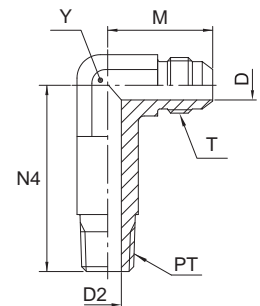

Tube O.D.		Thread NPT/NPTF PT	Thread UN/UNF-2A T	D mm	D2 mm	M mm	N4 mm	Y mm	Weight (steel) g/1 piece	Triple-Lok® Steel	PN (bar)
mm	in.										
6	1/4	1/8-27	7/16-20	4.4	4.8	23	40	11	32	4 CCCTX-S	420
6	1/4	1/4-18	7/16-20	4.4	7.0	27	53	14	32	4-4 CCCTX-S	420
8	5/16	1/8-27	1/2-20	6.0	4.8	25	41	14	39	5 CCCTX-S	420
10	3/8	1/4-18	9/16-18	7.5	7.2	27	53	14	72	6 CCCTX-S	420
10	3/8	3/8-18	9/16-18	7.5	10.3	29	59	19	72	6-6 CCCTX-S	420
12	1/2	3/8-18	3/4-16	10.3	9.9	32	59	19	130	8 CCCTX-S	420
12	1/2	1/2-14	3/4-16	9.9	13.5	34	73	22	163	8-8 CCCTX-S	420
14, 15, 16	5/8	1/2-14	7/8-14	12.3	13.5	37	73	22	212	10 CCCTX-S	350
18, 20	3/4	3/4-14	1 1/16-12	15.5	18.3	42	83	27	356	12 CCCTX-S	280
25	1	1-11.5	1 5/16-12	21.4	23.8	46	102	33	520	16 CCCTX-S	210
28, 30, 32	1 1/4	1 1/4-11.5	1 5/8-12	27.4	31.8	52	127	41	1196	20 CCCTX-S	170

Order codes shown are part of our current manufacturing programme.

Imperial and metric parts may vary in hexagon dimensions.

$$\frac{\text{PN (bar)}}{10} = \text{PN (MPa)}$$

Do not create drawings from these dimensions, they are subject to change and ISO manufacturing allowances.

C3MX Male stud elbow

Triple-Lok® 37° Flare end / Male BSPT thread (ISO 7)

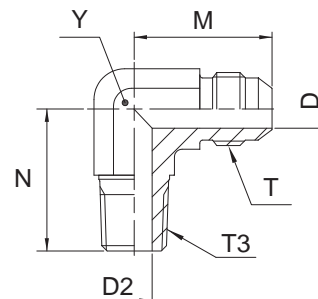

Tube O.D.		Thread BSPT T3	Thread UN/UNF-2A T	D mm	D2 mm	M mm	N mm	Y mm	Weight (steel) g/1 piece	Triple-Lok® Steel	Triple-Lok® Stainless Steel	PN (bar)	
mm	in.											S	SS
6	1/4	1/8-28	7/16-20	4.4	5.0	23	20	11	23	4C3MXS	4C3MXSS	315	315
6	1/4	1/4-19	7/16-20	4.4	7.0	27	28	14	42	4-4C3MXS	4-4C3MXSS	315	315
8	5/16	1/8-28	1/2-20	6.0	5.0	24	20	13	29	5C3MXS	5C3MXSS	315	315
8	5/16	1/4-19	1/2-20	6.0	7.0	27	28	14	42	5-4C3MXS	5-4C3MXSS	315	315
10	3/8	1/4-19	9/16-18	7.5	7.0	27	28	14	45	6C3MXS	6C3MXSS	315	315
10	3/8	3/8-19	9/16-18	7.5	10.0	29	31	19	76	6-6C3MXS	6-6C3MXSS	315	315
10	3/8	1/2-14	9/16-18	7.5	13.5	31	37	22	117	6-8C3MXS	6-8C3MXSS	315	315
12	1/2	3/8-19	3/4-16	9.9	10.0	32	31	19	86	8C3MXS	8C3MXSS	315	315
12	1/2	1/4-19	3/4-16	9.9	7.0	32	31	19	82	8-4C3MXS	8-4C3MXSS	315	315
12	1/2	1/2-14	3/4-16	9.9	13.5	34	37	22	125	8-8C3MXS	8-8C3MXSS	315	315
14, 15, 16	5/8	1/2-14	7/8-14	12.3	13.5	37	37	22	129	10C3MXS	10C3MXSS	315	315
14, 15, 16	5/8	3/8-19	7/8-14	12.3	10.3	37	33	22	127	10-6C3MXS	10-6C3MXSS	315	315
14, 15, 16	5/8	3/4-14	7/8-14	12.3	18.0	39	40	27	192	10-12C3MXS	10-12C3MXSS	160	160
18, 20	3/4	3/4-14	1 1/16-12	15.5	18.0	42	40	27	198	12C3MXS	12C3MXSS	160	160
18, 20	3/4	1/2-14	1 1/16-12	15.5	13.5	42	40	27	204	12-8C3MXS	12-8C3MXSS	315	315
18, 20	3/4	1-11	1 1/16-12	15.5	24.0	45	50	33	251	12-16C3MXS	12-16C3MXSS	160	160
25	1	1-11	1 5/16-12	21.5	24.0	46	50	33	328	16C3MXS	16C3MXSS	160	160
25	1	3/4-14	1 5/16-12	21.5	18.0	46	45	33	318	16-12C3MXS	16-12C3MXSS	160	160
28, 30, 32	1 1/4	1 1/4-11	1 5/8-12	27.5	32.0	52	61	41	549	20C3MXS	20C3MXSS	160	160
28, 30, 32	1 1/4	1-11	1 5/8-12	27.5	24.0	52	60	41	536	20-16C3MXS	20-16C3MXSS	160	160
35, 38	1 1/2	1 1/2-11	1 7/8-12	33.0	38.0	59	67	48	747	24C3MXS	24C3MXSS	160	140

Order codes shown are part of our current manufacturing programme.

Imperial and metric parts may vary in hexagon dimensions.

$$\frac{\text{PN (bar)}}{10} = \text{PN (MPa)}$$

Do not create drawings from these dimensions, they are subject to change and ISO manufacturing allowances.

K

V87OMX 45° Male stud elbow

Triple-Lok® 37° Flare end / Male metric thread O-ring (ISO 6149)

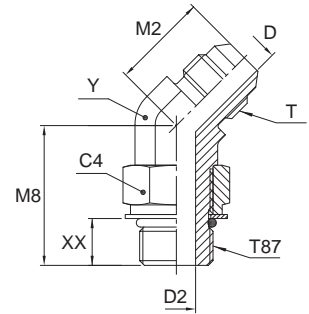

Tube O.D. mm	Tube O.D. in.	Thread Metric T87	Thread UN/UNF-2A T	C4 mm	D mm	D2 mm	M2 mm	M8 mm	XX mm	Y mm	Weight (steel) g/1 piece	Triple-Lok® Steel	PN (bar)
6	1/4	M 10×1.0	7/16-20	14	4.4	4.5	18	27	18	11	17	4M10V87OMXS	420
6	1/4	M 12×1.0	7/16-20	17	4.4	6.0	20	27	16	13	25	4M12V87OMXS	420
8	5/16	M 10×1.0	1/2-20	14	6.0	4.5	20	27	18	13	31	5M10V87OMXS	420
8	5/16	M 12×1.5	1/2-20	17	6.0	6.0	20	27	16	13	25	5M12V87OMXS	420
10	3/8	M 14×1.5	9/16-18	19	7.5	7.5	21	28	17	14	31	6M14V87OMXS	420
10	3/8	M 16×1.5	9/16-18	22	7.5	9.0	22	33	21	19	58	6M16V87OMXS	350
10	3/8	M 18×1.5	9/16-18	24	7.5	11.0	22	33	20	19	66	6M18V87OMXS	350
12	1/2	M 16×1.5	3/4-16	22	9.9	9.0	25	33	21	19	65	8M16V87OMXS	350
12	1/2	M 18×1.5	3/4-16	24	9.9	11.0	25	33	20	19	66	8M18V87OMXS	350
14, 15, 16	5/8	M 18×1.5	7/8-14	24	12.3	11.0	28	37	24	22	99	10M18V87OMXS	350
14, 15, 16	5/8	M 22×1.5	7/8-14	27	12.3	14.0	28	38	25	22	99	10M22V87OMXS	350
18, 20	3/4	M 22×1.5	1 1/16-12	27	15.5	14.0	33	40	27	27	164	12M22V87OMXS	350
18, 20	3/4	M 27×2.0	1 1/16-12	32	15.5	18.0	33	46	30	27	173	12M27V87OMXS	350
25	1	M 33×2.0	1 5/16-12	41	21.5	23.0	37	46	30	33	287	16M33V87OMXS	280

Steel, stainless steel and brass Triple-Lok® parts are delivered with NBR elastomeric seals as standard. For more details on other seal materials see page K92.

Order codes shown are part of our current manufacturing programme.

Imperial and metric parts may vary in hexagon dimensions.

$$\frac{\text{PN (bar)}}{10} = \text{PN (MPa)}$$

Do not create drawings from these dimensions, they are subject to change and ISO manufacturing allowances.

V5OMX 45° Male stud elbow

Triple-Lok® 37° Flare end / Male UNF thread O-ring (ISO 11926)
SAE 070320 MS51528

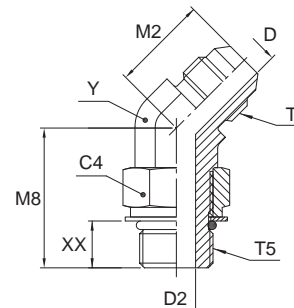

Tube O.D.		Thread UN/UNF-2A T5	Thread UN/UNF-2A T	C4 mm	D mm	D2 mm	M2 mm	M8 mm	XX mm	Y mm	Weight (steel) g/1 piece	Triple-Lok® Steel	Triple-Lok® Stainless Steel	PN (bar)	
mm	in.													S	SS
6	1/4	7/16-20	7/16-20	14.3	4.4	4.4	18	27	16	11.0	34	4 V5OX-S	4 V5OX-SS	420	350
8	5/16	1/2-20	1/2-20	16.0	6.0	6.0	20	27	16	14.0	42	5 V5OX-S	5 V5OX-SS	420	350
10	3/8	9/16-18	9/16-18	17.0	7.5	7.5	21	29	17	14.0	52	6V5OMXS	6 V5OX-SS	420	350
10	3/8	3/4-16	9/16-18	22.2	7.5	9.9	22	23	19	19.0	104	6-8 V5OX-S	6-8 V5OX-SS	420	350
12	1/2	3/4-16	3/4-16	22.2	9.9	9.9	25	33	19	19.0	104	8 V5OX-S	8 V5OX-SS	420	350
12	1/2	9/16-18	3/4-16	17.5	9.9	7.5	25	28	16	19.0	98	8-6 V5OX-S	8-6 V5OX-SS	420	350
12	1/2	7/8-14	3/4-16	25.4	9.9	12.3	25	39	23	22.0	148	8-10 V5OX-S	8-10 V5OX-SS	350	350
14, 15,16	5/8	7/8-14	7/8-14	25.4	12.3	12.3	28	39	23	22.0	157	10 V5OX-S	10 V5OX-SS	350	350
14, 15,16	5/8	3/4-16	7/8-14	22.2	12.3	9.9	28	35	21	22.0	157	10-8 V5OX-S	10-8 V5OX-SS	350	350
18, 20	3/4	1 1/16-12	1 1/16-12	31.8	15.5	15.5	33	44	26	27.0	258	12 V5OX-S	12 V5OX-SS	350	350
18, 20	3/4	7/8-14	1 1/16-12	25.4	15.5	12.5	33	40	25	27.0	227	12-10 V5OX-S	12-10 V5OX-SS	350	350
22	7/8	1 3/16-12	1 3/16-12	35.0	18.3	18.3	37	47	30	33.3	275	14 V5OX-S		280	—
25	1	1 5/16-12	1 5/16-12	38.0	21.4	21.4	37	47	30	33.3	375	16 V5OX-S	16 V5OX-SS	280	280
25	1	1 1/16-12	1 5/16-12	31.8	21.4	15.5	37	47	31	33.3	277	16-12 V5OX-S		280	280
28, 30, 32	1 1/4	1 5/8-12	1 5/8-12	47.6	27.4	27.4	40	49	31	41.0	570	20 V5OX-S	20 V5OX-SS	280	210
35, 38	1 1/2	1 7/8-12	1 7/8-12	54.0	33.3	33.3	45	49	31	47.6	706	24 V5OX-S	24 V5OX-SS	210	140

Steel, stainless steel and brass Triple-Lok® parts are delivered with NBR elastomeric seals as standard. For more details on other seal materials see page K92.

Order codes shown are part of our current manufacturing programme.

Imperial and metric parts may vary in hexagon dimensions.

$$\frac{\text{PN (bar)}}{10} = \text{PN (MPa)}$$

Do not create drawings from these dimensions, they are subject to change and ISO manufacturing allowances.

K

V4OMX 45° Male stud elbow

Triple-Lok® 37° Flare end / Male BSPP thread O-ring + retaining ring (ISO 1179)

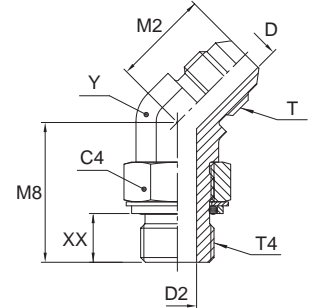

Tube O.D.		Thread BSPP T4	Thread UN/UNF-2A T	C4 mm	D mm	D2 mm	M2 mm	M8 mm	XX mm	Y mm	Weight (steel) g/1 piece	Triple-Lok® Steel	PN (bar)
mm	in.												
6	1/4	1/8-28	7/16-20	14	4.4	4.4	18	27	18	11	35	4V4OMXS	250
6	1/4	1/4-19	7/16-20	19	4.4	7.5	21	29	18	14	48	4-4V4OMXS	250
8	5/16	1/8-28	1/2-20	14	6.0	4.4	20	27	18	13	44	5V4OMXS	250
8	5/16	1/4-19	1/2-20	19	6.0	7.5	21	27	15	14	51	5-4V4OMXS	250
10	3/8	1/4-19	9/16-18	19	7.5	7.5	21	29	18	14	55	6V4OMXS	250
10	3/8	3/8-19	9/16-18	22	7.5	9.9	22	33	22	19	70	6-6V4OMXS	250
10	3/8	1/2-14	9/16-18	27	7.5	12.3	22	39	24	22	92	6-8V4OMXS	250
12	1/2	3/8-19	3/4-16	22	9.9	9.9	25	33	22	19	104	8V4OMXS	250
12	1/2	1/2-14	3/4-16	27	9.9	12.3	25	39	24	22	148	8-8V4OMXS	250
14, 15, 16	5/8	1/2-14	7/8-14	27	12.3	12.3	28	39	24	22	165	10V4OMXS	250
14, 15, 16	5/8	3/4-14	7/8-14	36	12.3	15.5	30	44	29	27	235	10-12V4OMXS	250
18, 20	3/4	3/4-14	1 1/16-12	36	15.5	15.5	33	44	30	27	270	12V4OMXS	250
25	1	1-11	1 5/16-12	41	21.5	21.5	37	47	31	33	394	16V4OMXS	250
28, 30, 32	1 1/4	1 1/4-11	1 5/8-12	50	27.5	27.5	40	48	32	41	599	20V4OMXS	210
35, 38	1 1/2	1 1/2-11	1 7/8-12	55	33.0	33.0	45	48	33	48	750	24V4OMXS	140

Steel, stainless steel and brass Triple-Lok® parts are delivered with NBR elastomeric seals as standard. For more details on other seal materials see page K92.

Order codes shown are part of our current manufacturing programme.

Imperial and metric parts may vary in hexagon dimensions.

$$\frac{\text{PN (bar)}}{10} = \text{PN (MPa)}$$

Do not create drawings from these dimensions, they are subject to change and ISO manufacturing allowances.

V8OMX 45° Male stud elbow

Triple-Lok® 37° Flare end / Male metric thread – O-ring + retaining ring

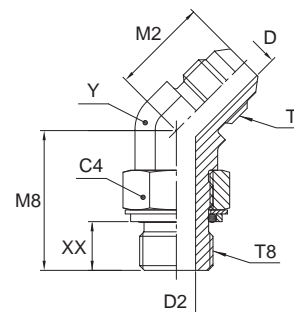

Tube O.D. mm	in.	Thread Metric T8	Thread UN/UNF-2A T	C4 mm	D mm	D2 mm	M2 mm	M8 mm	XX mm	Y mm	Weight (steel) g/1 piece	Triple-Lok® Steel	PN (bar)
6	1/4	M 10×1.0	7/16-20	14	4.4	4.5	18	27	20	11	23	4M10V8OMXS	250
6	1/4	M 12×1.5	7/16-20	17	4.4	6.0	20	27	18	13	25	4M12V8OMXS	250
8	5/16	M 12×1.5	1/2-20	17	6.0	6.0	20	28	18	13	28	5M12V8OMXS	250
10	3/8	M 14×1.5	9/16-18	17	7.5	7.5	21	28	19	14	36	6M14V8OMXS	250
12	1/2	M 16×1.5	3/4-16	19	9.9	9.0	25	33	23	19	68	8M16V8OMXS	250
12	1/2	M 18×1.5	3/4-16	22	9.9	11.0	25	33	22	19	78	8M18V8OMXS	250
14, 15, 16	5/8	M 22×1.5	7/8-14	27	12.3	14.0	28	38	27	22	119	10M22V8OMXS	250
18, 20	3/4	M 27×2.0	1 1/16-12	32	15.5	18.0	33	46	32	27	208	12M27V8OMXS	175
25	1	M 33×2.0	1 5/16-12	38	21.5	23.0	37	46	32	33	333	16M33V8OMXS	140

Steel, stainless steel and brass Triple-Lok® parts are delivered with NBR elastomeric seals as standard. For more details on other seal materials see page K92.

Order codes shown are part of our current manufacturing programme.

Imperial and metric parts may vary in hexagon dimensions.

$$\frac{\text{PN (bar)}}{10} = \text{PN (MPa)}$$

Do not create drawings from these dimensions, they are subject to change and ISO manufacturing allowances.

VMTX 45° Male stud elbow

Triple-Lok® 37° Flare end / Male NPTF* thread (SAE 476)

SAE 070302 MS51508

*Stainless Steel = NPT to prevent galling

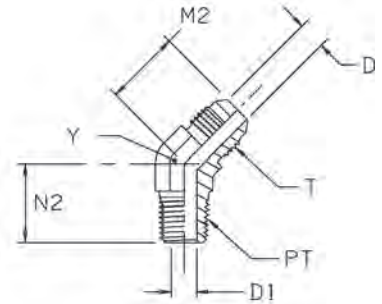

Tube O.D.		Thread NPT/NPTF PT	Thread UN/UNF-2A T	D mm	D1 mm	M2 mm	N2 mm	Y mm	Weight (steel) g/1 piece	Triple-Lok®			PN (bar)	
mm	in.									Steel	Stainless Steel	Brass	S	SS
6	1/4	1/8-27	7/16-20	4.4	4.8	18	16	11.0	18	4 VTX-S	4 VTX-SS	4 VTX-B	420	350
6	1/4	1/4-18	7/16-20	4.4	7.0	21	22	14.0	30	4-4 VTX-S	4-4 VTX-SS	4-4 VTX-B	420	350
6	1/4	3/8-18	9/16-18	4.4	10.3	22	24	19.0	54	4-6 VTX-S			420	350
8	5/16	1/8-27	1/2-20	6.0	4.8	20	16	14.0	22	5 VTX-S	5 VTX-SS	5 VTX-B	420	350
8	5/16	1/4-18	1/2-20	6.0	7.0	21	22	14.0	31	5-4 VTX-S	5-4 VTX-SS	5-4 VTX-B	420	350
10	3/8	1/4-18	9/16-18	7.5	7.0	21	22	14.0	27	6 VTX-S	6 VTX-SS	6 VTX-B	420	350
10	3/8	1/8-27	9/16-18	7.5	4.7	21	17	14.0	23	6-2 VTX-S	6-2 VTX-SS	6-2 VTX-B	420	350
10	3/8	3/8-18	9/16-18	7.5	10.3	22	24	19.0	52	6-6 VTX-S	6-6 VTX-SS	6-6 VTX-B	420	350
10	3/8	1/2-14	9/16-18	7.5	13.5	22	30	22.0	74	6-8 VTXS	6-8 VTX-SS	6-8 VTX-B	420	350
12	1/2	1/4-18	3/4-16	9.9	7.0	25	24	19.0	62	8-4 VTX-S	8-4 VTX-SS	8-4 VTX-B	420	350
12	1/2	3/8-18	3/4-16	9.9	10.3	25	24	19.0	61	8 VTX-S	8 VTX-SS	8 VTX-B	420	350
12	1/2	1/2-14	3/4-16	9.9	13.5	25	30	22.0	92	8-8 VTX-S	8-8 VTX-SS	8-8 VTX-B	420	350
12	1/2	3/4-14	3/4-16	9.9	18.2	26	31	27.0	144	8-12 VTX-S	8-12 VTX-SS	8-12 VTX-B	280	280
14, 15,16	5/8	1/2-14	7/8-14	12.3	13.5	28	30	22.0	92	10 VTX-S	10 VTX-SS	10 VTX-B	350	350
14, 15,16	5/8	3/8-18	7/8-14	12.3	10.3	28	25	22.0	94	10-6 VTX-S	10-6 VTX-SS	10-6 VTX-B	350	350
14, 15,16	5/8	3/4-14	7/8-14	12.3	18.2	33	31	27.0	156	10-12 VTX-S	10-12 VTX-SS		280	280
18, 20	3/4	3/4-14	1 1/16-12	15.5	18.2	33	31	27.0	148	12 VTX-S	12 VTX-SS	12 VTX-B	280	280
18, 20	3/4	1/2-14	1 1/16-12	15.5	13.5	33	31	27.0	144	12-8 VTX-S	12-8 VTX-SS	12-8 VTX-B	350	350
18, 20	3/4	1-11.5	1 1/16-12	15.5	23.8	36	38	33.3	169	12-16 VTX-S	12-16 VTX-SS	12-16 VTX-B	210	210
25	1	1-11.5	1 5/16-12	21.4	23.8	37	38	33.3	239	16 VTX-S	16 VTX-SS	16 VTX-B	210	210
25	1	3/4-14	1 5/16-12	21.4	18.2	37	33	33.3	213	16-12 VTX-S	16-12 VTX-SS	16-12 VTX-B	280	280
28, 30, 32	1 1/4	1 1/4-11.5	1 5/8-12	27.4	31.8	40	42	41.0	385	20 VTX-S	20 VTX-SS	20 VTX-B	170	170
35, 38	1 1/2	1 1/2-11.5	1 7/8-12	33.3	38.0	45	45	47.6	495	24 VTX-S	24 VTX-SS	24 VTX-B	170	140
	2	2-11.5	2 1/2-12	45.0	49.0	56	54	63.5	1149	32 VTX-S			170	140

Order codes shown are part of our current manufacturing programme.

Imperial and metric parts may vary in hexagon dimensions.

$$\frac{PN \text{ (bar)}}{10} = PN \text{ (MPa)}$$

Pressure ratings – PN shown, apply to Steel and Stainless Steel versions of the product.

For Brass parts reduce pressures by 35%.

Do not create drawings from these dimensions, they are subject to change and ISO manufacturing allowances.

V3MX 45° Male stud elbow

Triple-Lok® 37° Flare end / Male BSPT thread (ISO 7)

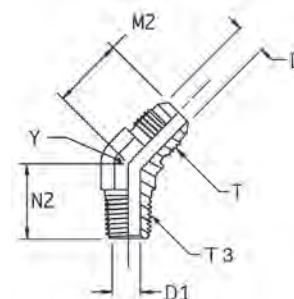

Tube O.D.		Thread BSPT T3	Thread UN/UNF-2A T	D mm	D1 mm	M2 mm	N2 mm	Y mm	Weight (steel) g/1 piece	Triple-Lok® Steel	PN (bar)
mm	in.										
6	1/4	1/8-28	7/16-20	4.4	5.0	18	16	11	18	4V3MXS	315
6	1/4	1/4-19	7/16-20	4.4	7.0	21	22	14	30	4-4V3MXS	315
8	5/16	1/8-28	1/2-20	6.0	5.0	20	16	13	22	5V3MXS	315
8	5/16	1/4-19	1/2-20	6.0	7.0	21	22	14	31	5-4V3MXS	315
10	3/8	1/4-19	9/16-18	7.5	7.0	21	22	14	27	6V3MXS	315
10	3/8	3/8-19	9/16-18	7.5	10.0	22	24	19	52	6-6V3MXS	315
10	3/8	1/2-14	9/16-18	7.5	13.5	22	30	22	74	6-8V3MXS	315
12	1/2	3/8-19	3/4-16	9.9	10.0	25	24	19	61	8V3MXS	315
12	1/2	1/2-14	3/4-16	9.9	13.5	25	30	22	92	8-8V3MXS	315
14, 15, 16	5/8	1/2-14	7/8-14	12.3	13.5	28	30	22	92	10V3MXS	315
18, 20	3/4	3/4-14	7/8-14	15.5	18.0	33	31	27	148	12V3MXS	160
25	1	1-11	1 5/16-12	21.5	24.0	37	38	33	239	16V3MXS	160
28, 30, 32	1 1/4	1 1/4-11	1 5/8-12	27.5	32.0	40	42	41	385	20V3MXS	160
35, 38	1 1/2	1 1/2-11	1 7/8-12	33.0	38.0	45	45	48	495	24V3MXS	160

Order codes shown are part of our current manufacturing programme.

Imperial and metric parts may vary in hexagon dimensions.

$$\frac{\text{PN (bar)}}{10} = \text{PN (MPa)}$$

Do not create drawings from these dimensions, they are subject to change and ISO manufacturing allowances.

S87OMX Male stud branch tee

Triple-Lok® 37° Flare ends / Male metric thread O-ring (ISO 6149)

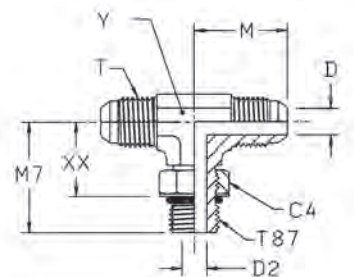

Tube O.D. mm	Tube O.D. in.	Thread Metric T87	Thread UN/UNF-2A T	C4 mm	D mm	D2 mm	M mm	M7 mm	XX mm	Y mm	Weight (steel) g/1 piece	Triple-Lok® Steel	PN (bar)
6	1/4	M 10×1.0	7/16-20	14	4.4	4.5	23	27	18	11	27	4M10S87OMXS	420
8	5/16	M 12×1.5	1/2-20	17	6.0	6.0	24	31	19	13	42	5M12S87OMXS	420
10	3/8	M 14×1.5	9/16-18	19	7.5	7.5	27	34	22	14	53	6M14S87OMXS	420
12	1/2	M 16×1.5	3/4-16	22	9.9	9.0	32	38	26	19	113	8M16S87OMXS	350
12	1/2	M 18×1.5	3/4-16	24	9.9	11.0	32	38	26	19	114	8M18S87OMXS	350
14, 15,16	5/8	M 18×1.5	7/8-14	24	12.3	11.0	37	42	29	22	174	10M18S87OMXS	350
14, 15,16	5/8	M 22×1.5	7/8-14	27	12.3	14.0	37	43	29	22	175	10M22S87OMXS	350
18, 20	3/4	M 22×1.5	1 1/16-12	27	15.5	14.0	42	45	32	27	295	12M22S87OMXS	350
18, 20	3/4	M 27×2.0	1 1/16-12	32	15.5	18.0	42	51	35	27	304	12M27S87OMXS	350
25	1	M 33×2.0	1 5/16-12	41	21.5	23.0	46	53	38	33	530	16M33S87OMXS	280

Steel, stainless steel and brass Triple-Lok® parts are delivered with NBR elastomeric seals as standard. For more details on other seal materials see page K92.

Order codes shown are part of our current manufacturing programme.

Imperial and metric parts may vary in hexagon dimensions.

$$\frac{\text{PN (bar)}}{10} = \text{PN (MPa)}$$

Do not create drawings from these dimensions, they are subject to change and ISO manufacturing allowances.

S50MX Male stud branch tee

Triple-Lok® 37° Flare ends / Male UNF thread O-ring (ISO 11926)
SAE 070429 MS51529

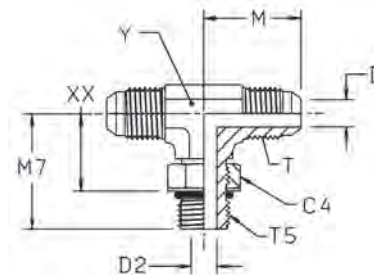

Tube O.D.		Thread UN/UNF-2A T5	Thread UN/UNF-2A T	C4 mm	D mm	D2 mm	M mm	M7 mm	XX mm	Y mm	Weight (steel) g/1 piece	Triple-Lok® Steel	Triple-Lok® Stainless Steel	PN (bar)	
mm	in.													S	SS
6	1/4	7/16-20	7/16-20	14.3	4.4	4.4	23	26	15	11.0	46	4 S50X-S	4 S50X-SS	420	350
8	5/16	1/2-20	1/2-20	16.0	5.8	5.8	24	29	18	14.0	66	5 S50X-S	5 S50X-SS	420	350
10	3/8	9/16-18	9/16-18	17.5	7.5	7.5	27	32	20	14.0	76	6 S50X-S	6 S50X-SS	420	350
12	1/2	3/4-16	3/4-16	22.0	9.9	10.0	32	37	23	19.0	150	8S50MXS	8 S50X-SS	420	350
14, 15, 16	5/8	7/8-14	7/8-14	27.0	12.3	12.5	37	43	28	22.0	224	10S50MXS	10 S50X-SS	350	350
18, 20	3/4	1 1/16-12	1 1/16-12	31.8	15.5	15.5	42	49	31	27.0	367	12 S50X-S	12 S50X-SS	350	350
25	1	1 5/16-12	1 5/16-12	38.0	21.4	21.4	46	52	34	33.3	506	16 S50X-S	16 S50X-SS	280	280
28, 30, 32	1 1/4	1 5/8-12	1 5/8-12	47.6	27.4	27.4	52	57	40	41.0	1053	20 S50X-S	20 S50X-SS	280	280
35, 38	1 1/2	1 7/8-12	1 7/8-12	54.0	33.3	33.3	59	61	43	47.6	1296	24 S50X-S		210	—
	2	2 1/2-12	2 1/2-12	69.8	45.2	45.2	78	73	56	63.5	2000	32 S50X-S		140	—

Steel, stainless steel and brass Triple-Lok® parts are delivered with NBR elastomeric seals as standard. For more details on other seal materials see page K92.

Order codes shown are part of our current manufacturing programme.

Imperial and metric parts may vary in hexagon dimensions.

$$\frac{\text{PN (bar)}}{10} = \text{PN (MPa)}$$

Do not create drawings from these dimensions, they are subject to change and ISO manufacturing allowances.

K

S4OMX Male stud branch tee

Triple-Lok® 37° Flare end / Adjustable BSPP thread O-ring + retaining ring (ISO 1179)

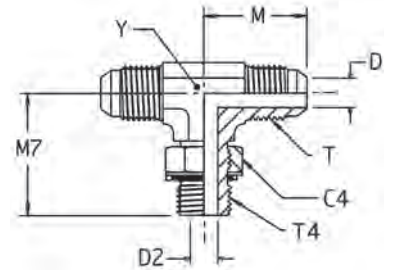

Tube O.D.		Thread BSPP T4	Thread UN/UNF-2A T	C4 mm	D mm	D2 mm	M mm	M7 mm	XX mm	Y mm	Weight (steel) g/1 piece	Triple-Lok® Steel	Triple-Lok® Stainless Steel	PN (bar)	
mm	in.													S	SS
6	1/4	1/8-28	7/16-20	14	4.4	4.4	23	27	17	11	47	4S4OMXS	4S4OMXSS	250	250
10	3/8	1/4-19	9/16-18	19	7.5	7.5	27	32	19	14	78	6S4OMXS	6S4OMXSS	250	200
12	1/2	3/8-19	3/4-16	22	9.9	10.0	32	37	24	19	154	8S4OMXS	8S4OMXSS	250	200
12	1/2	1/2-14	3/4-16	27	9.9	12.3	34	44	28	22	186	8-8-8S4OMXS	8-8-8S4OMXSS	250	200
14, 15, 16	5/8	1/2-14	7/8-14	27	12.3	12.3	37	43	27	22	231	10S4OMXS	10S4OMXSS	250	200
18, 20	3/4	3/4-14	1 1/16-12	36	15.5	15.5	42	50	34	27	379	12S4OMXS	12S4OMXSS	250	200
25	1	1-11	1 5/16-12	41	21.5	21.5	46	52	35	33	569	16S4OMXS	16S4OMXSS	250	200
28, 30, 32	1 1/4	1 1/4-11	1 5/8-12	50	27.5	27.5	52	57	39	41	1075	20S4OMXS	20S4OMXSS	210	160

Steel, stainless steel and brass Triple-Lok® parts are delivered with NBR elastomeric seals as standard. For more details on other seal materials see page K92.

Order codes shown are part of our current manufacturing programme.

Imperial and metric parts may vary in hexagon dimensions.

$$\frac{PN \text{ (bar)}}{10} = PN \text{ (MPa)}$$

Do not create drawings from these dimensions, they are subject to change and ISO manufacturing allowances.

S8OMX Male stud branch tee

Triple-Lok® 37° Flare ends / Male metric thread – O-ring + retaining ring

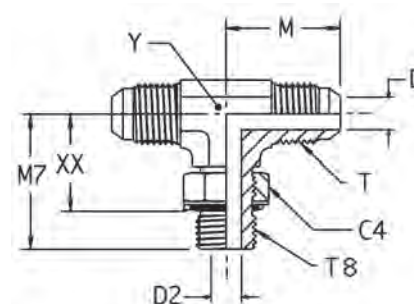

Tube O.D. mm	in.	Thread Metric T8	Thread UN/UNF-2A T	C4 mm	D mm	D2 mm	M mm	M7 mm	XX mm	Y mm	Weight (steel) g/1 piece	Triple-Lok® Steel	PN (bar)
6	1/4	M 10×1.0	7/16-20	14	4.4	4.5	23	27	18	11	27	4M10S8OMXS	250
8	5/16	M 12×1.5	1/2-20	17	6.0	6.0	24	31	19	13	42	5M12S8OMXS	250
10	3/8	M 14×1.5	9/16-18	17	7.5	7.5	27	34	22	14	53	6M14S8OMXS	250
12	1/2	M 16×1.5	3/4-16	19	9.9	9.0	32	38	26	19	95	8M16S8OMXS	250
12	1/2	M 18×1.5	3/4-16	22	9.9	11.0	32	38	26	19	114	8M18S8OMXS	250
14, 15,16	5/8	M 22×1.5	7/8-14	27	12.3	14.0	37	43	30	22	175	10M22S8OMXS	250
18, 20	3/4	M 27×2.0	1 1/16-12	32	15.5	18.0	42	51	35	27	304	12M27S8OMXS	175
25	1	M 33×2.0	1 5/16-12	38	21.5	23.0	46	53	37	33	491	16M33S8OMXS	140

Steel, stainless steel and brass Triple-Lok® parts are delivered with NBR elastomeric seals as standard. For more details on other seal materials see page K92.

Order codes shown are part of our current manufacturing programme.

Imperial and metric parts may vary in hexagon dimensions.

$$\frac{\text{PN (bar)}}{10} = \text{PN (MPa)}$$

Do not create drawings from these dimensions, they are subject to change and ISO manufacturing allowances.

SMTX Male stud branch tee

Triple-Lok® 37° Flare ends / Male NPTF* thread (SAE 476)

SAE 070425 MS51512

*Stainless Steel = NPT to prevent galling

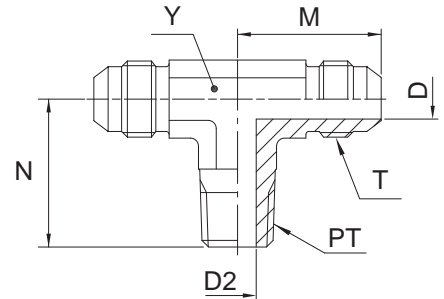

Tube O.D.		Thread NPT/NPTF PT	Thread UN/UNF-2A T	D mm	D2 mm	M mm	N mm	Y mm	Weight (steel) g/1 piece	Triple-Lok® Steel	Triple-Lok® Stainless Steel	Triple-Lok® Brass	PN (bar)	
mm	in.												S	SS
6	3/16	1/8-27	3/8-24	3.0	4.7	21	18	11.0	25	3 STX-S	3 STX-SS	3 STX-B	420	350
	1/4	1/8-27	7/16-20	4.4	4.7	23	20	11.0	31	4 STX-S	4 STX-SS	4 STX-B	420	350
	1/4	1/4-18	7/16-20	4.4	7.0	27	28	14.0	49	4-4-4 STX-S	4-4-4 STX-SS	4-4-4 STX-B	420	350
	5/16	1/8-27	1/2-20	6.0	4.7	25	21	14.0	37	5 STX-S	5 STX-SS	5 STX-B	420	350
10	3/8	1/4-18	9/16-18	7.5	7.0	27	28	14.0	57	6 STX-S	6 STX-SS	6 STX-B	420	350
	3/8	3/8-18	9/16-18	7.5	10.3	29	31	19.0	77	6-6-6 STX-S	6-6-6 STX-SS	6-6-6 STX-B	420	350
12	1/2	3/8-18	3/4-16	9.9	10.3	32	31	19.0	113	8 STX-S	8 STX-SS	8 STX-B	420	350
	1/2	1/2-14	3/4-16	9.9	13.5	34	37	22.0	164	8-8-8 STX-S	8-8-8 STX-SS	8-8-8 STX-B	420	350
14, 15, 16	5/8	1/2-14	7/8-14	12.3	13.5	37	37	22.0	173	10 STX-S	10 STX-SS	10 STX-B	350	350
	3/4	3/4-14	1 1/16-12	18.0	18.3	42	40	27.0	272	12 STX-S	12 STX-SS	12 STX-B	280	280
22	7/8	3/4-14	1 3/16-12	18.3	18.3	46	43	33.3	323	14 STX-S			280	—
25	1	1-11.5	1 5/16-12	21.4	23.8	46	50	33.3	413	16 STX-S	16 STX-SS	16 STX-B	210	210
28, 30, 32	1 1/4	1 1/4-11.5	1 5/8-12	27.4	31.8	52	60	41.0	681	20 STX-S	20 STX-SS	20 STX-B	170	170
	2	1 1/2-11.5	1 7/8-12	33.3	38.0	59	67	47.6	905	24 STX-S	24 STX-SS	24 STX-B	170	170

Order codes shown are part of our current manufacturing programme.

Imperial and metric parts may vary in hexagon dimensions.

$$\frac{PN \text{ (bar)}}{10} = PN \text{ (MPa)}$$

Pressure ratings – PN shown, apply to Steel and Stainless Steel versions of the product.

For Brass parts reduce pressures by 35 %.

Do not create drawings from these dimensions, they are subject to change and ISO manufacturing allowances.

S3MX Male stud branch tee

Triple-Lok® 37° Flare ends / Male BSPT thread (ISO 7)

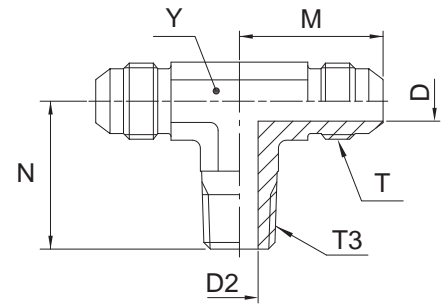

Tube O.D.		Thread BSPT T3	Thread UN/UNF-2A T	D mm	D2 mm	M mm	N mm	Y mm	Weight (steel) g/1 piece	Triple-Lok® Steel	Triple-Lok® Stainless Steel	PN (bar)	
mm	in.											S	SS
6	1/4	1/8-28	7/16-20	4.4	5.0	23	20	11	30	4S3MXS	4S3MXSS	315	315
10	3/8	1/4-19	7/16-20	7.5	7.0	27	28	14	55	6S3MXS	6S3MXSS	315	315
12	1/2	3/8-19	3/4-16	9.9	10.0	32	31	19	111	8S3MXS	8S3MXSS	315	315
14, 15, 16	5/8	1/2-14	7/8-14	12.3	13.5	37	37	22	169	10S3MXS	10S3MXSS	315	315
18, 20	3/4	3/4-14	1 1/16-12	15.5	18.0	42	40	27	267	12S3MXS	12S3MXSS	160	160
25	1	1-11	1 5/16-12	21.5	24.0	46	50	33	407	16S3MXS	16S3MXSS	160	160

Order codes shown are part of our current manufacturing programme.

Imperial and metric parts may vary in hexagon dimensions.

$$\frac{\text{PN (bar)}}{10} = \text{PN (MPa)}$$

Do not create drawings from these dimensions, they are subject to change and ISO manufacturing allowances.

R87OMX Male stud run tee

Triple-Lok® 37° Flare ends / Male metric thread – O-ring (ISO 6149)

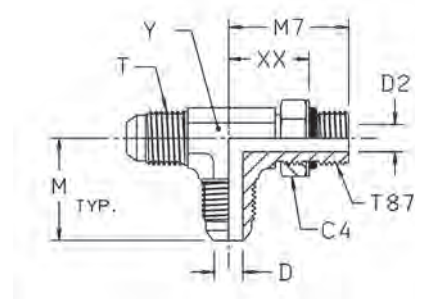

Tube O.D. mm	Tube O.D. in.	Thread Metric T87	Thread UN/UNF-2A T	C4 mm	D mm	D2 mm	M mm	M7 mm	XX mm	Y mm	Weight (steel) g/1 piece	Triple-Lok® Steel	PN (bar)
6	1/4	M 10×1.0	7/16-20	14	4.4	4.5	23	27	18	11	27	4M10R87OMXS	420
10	3/8	M 14×1.5	9/16-18	19	7.5	7.5	27	34	22	14	53	6M14R87OMXS	420
12	1/2	M 16×1.5	3/4-16	22	9.9	9.0	32	38	26	19	113	8M16R87OMXS	350
12	1/2	M 18×1.5	3/4-16	24	9.9	11.0	32	38	26	19	114	8M18R87OMXS	350
14, 15, 16	5/8	M 18×1.5	7/8-14	24	12.3	11.0	37	42	29	22	174	10M18R87OMXS	350
14, 15, 16	5/8	M 22×1.5	7/8-14	27	12.3	14.0	37	43	29	22	175	10M22R87OMXS	350
18, 20	3/4	M 27×2.0	1 1/16-12	32	15.5	18.0	42	51	35	27	315	12M27R87OMXS	350
25	1	M 33×2.0	1 5/16-12	41	22.5	23.0	46	53	38	33	495	16M33R87OMXS	280

Steel, stainless steel and brass Triple-Lok® parts are delivered with NBR elastomeric seals as standard. For more details on other seal materials see page K92.

Order codes shown are part of our current manufacturing programme.

Imperial and metric parts may vary in hexagon dimensions.

$\frac{\text{PN (bar)}}{10} = \text{PN (MPa)}$

Do not create drawings from these dimensions, they are subject to change and ISO manufacturing allowances.

R5OMX Male stud run tee

Triple-Lok® 37° Flare ends / Male UNF thread O-ring (ISO 11926)

SAE 070428 MS51530

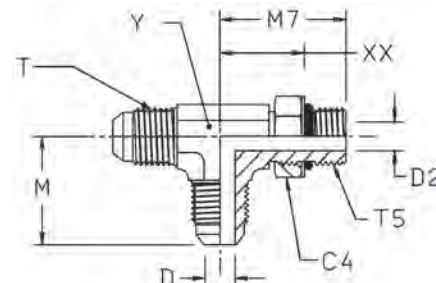

Tube O.D.		Thread UN/UNF-2A T5	Thread UN/UNF-2A T	C4 mm	D mm	D2 mm	M mm	M7 mm	XX mm	Y mm	Weight (steel) g/1 piece	Triple-Lok® Steel	Triple-Lok® Stainless Steel	PN (bar)	
mm	in.													S	SS
6	1/4	7/16-20	7/16-20	14.0	4.4	4.4	23	26	16	11.0	46	4 R5OX-S	4 R5OX-SS	420	350
8	5/16	1/2-20	1/2-20	16.0	6.0	6.0	24	29	18	14.0	66	5 R5OX-S	5 R5OX-SS	420	350
10	3/8	9/16-18	9/16-18	17.5	7.5	7.5	27	32	20	14.0	76	6 R5OX-S	6 R5OX-SS	420	350
12	1/2	3/4-16	3/4-16	22.2	9.9	10.0	32	37	23	19.0	151	8 R5OX-S	8 R5OX-SS	420	350
14, 15, 16	5/8	7/8-14	7/8-14	25.0	12.3	12.3	37	43	28	22.0	226	10 R5OX-S	10 R5OX-SS	350	350
18, 20	3/4	1 1/16-12	1 1/16-12	32.0	15.5	15.5	42	49	32	27.0	372	12 R5OX-S	12 R5OX-SS	350	350
25	1	1 5/16-12	1 5/16-12	38.0	21.4	21.4	46	52	35	33.3	557	16 R5OX-S	16 R5OX-SS	280	280
28, 30, 32	1 1/4	1 5/8-12	1 5/8-12	48.0	27.4	27.4	52	57	40	41.0	1053	20 R5OX-S	20 R5OX-SS	280	280
35, 38	1 1/2	1 7/8-12	1 7/8-12	54.0	33.3	33.3	59	61	43	47.6	1296	24 R5OX-S	24 R5OX-SS	210	210
	2	2 1/2-12	2 1/2-12	70.0	45.2	45.2	78	73	56	66.0	2000	32 R5OX-S	32 R5OX-SS	140	140

Steel, stainless steel and brass Triple-Lok® parts are delivered with NBR elastomeric seals as standard. For more details on other seal materials see page K92.

Order codes shown are part of our current manufacturing programme.

Imperial and metric parts may vary in hexagon dimensions.

$$\frac{\text{PN (bar)}}{10} = \text{PN (MPa)}$$

Do not create drawings from these dimensions, they are subject to change and ISO manufacturing allowances.

K

R4OMX Male stud run tee

Triple-Lok® 37° Flare end / Adjustable BSPP thread O-ring + retaining ring (ISO 1179)

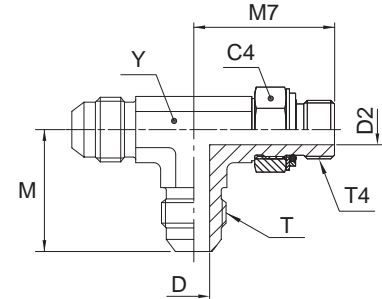

Tube O.D.		Thread BSPP T4	Thread UN/UNF-2A T	C4 mm	D mm	D2 mm	M mm	M7 mm	XX mm	Y mm	Weight (steel) g/1 piece	Triple-Lok® Steel	Triple-Lok® Stainless Steel	PN (bar)	
mm	in.													S	SS
6	1/4	1/8-28	7/16-20	14	4.4	4.4	23	27	17	11	47	4R4OMXS	4R4OMXSS	250	200
10	3/8	1/4-19	9/16-18	19	7.5	7.5	27	32	19	14	78	6R4OMXS	6R4OMXSS	250	200
12	1/2	3/8-19	3/4-16	22	9.9	9.9	32	37	24	19	154	8R4OMXS	8R4OMXSS	250	200
14, 15, 16	5/8	1/2-14	7/8-14	27	12.3	12.3	37	43	27	22	231	10R4OMXS	10R4OMXSS	250	200
18, 20	3/4	3/4-14	1 1/16-12	36	15.5	15.5	42	50	34	27	379	12R4OMXS	12R4OMXSS	250	200
25	1	1-11	1 5/16-12	41	21.5	21.5	46	52	34	33	569	16R4OMXS	16R4OMXSS	250	200
28, 30, 32	1 1/4	1 1/4-11	1 5/8-12	50							1075	20R4OMXS	20R4OMXSS	210	160

Steel, stainless steel and brass Triple-Lok® parts are delivered with NBR elastomeric seals as standard. For more details on other seal materials see page K92.

Order codes shown are part of our current manufacturing programme.

Imperial and metric parts may vary in hexagon dimensions.

$$\frac{\text{PN (bar)}}{10} = \text{PN (MPa)}$$

Do not create drawings from these dimensions, they are subject to change and ISO manufacturing allowances.

R8OMX Male stud run tee

Triple-Lok® 37° Flare ends / Male metric thread – O-ring + retaining ring

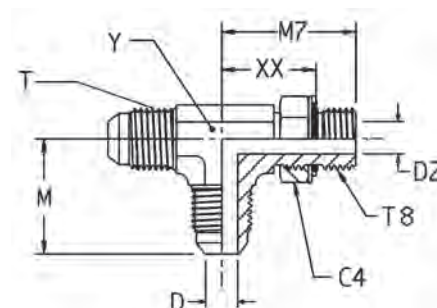

Tube O.D. mm	in.	Thread Metric T8	Thread UN/UNF-2A T	C4 mm	D mm	D2 mm	M mm	M7 mm	XX mm	Y mm	Weight (steel) g/1 piece	Triple-Lok® Steel	PN (bar)
6	1/4	M 10×1.0	7/16-20	14	4.4	4.5	23	27	18	11	27	4M10R8OMXS	250
8	5/16	M 12×1.5	1/2-20	17	6.0	6.0	24	31	20	13	42	5M12R8OMXS	250
10	3/8	M 14×1.5	9/16-18	17	7.5	7.5	27	34	23	14	53	6M14R8OMXS	250
12	1/2	M 16×1.5	3/4-16	19	9.9	9.0	32	38	27	19	95	8M16R8OMXS	250
12	1/2	M 18×1.5	3/4-16	22	9.9	9.9	32	38	26	19	114	8M18R8OMXS	250
14, 15, 16	5/8	M 22×1.5	7/8-14	27	12.3	14.0	37	43	29	22	175	10M22R8OMXS	250
18, 20	3/4	M 27×2.0	1 1/16-12	32	15.5	18.0	42	51	35	27	304	12M27R8OMXS	175
25	1	M 33×2.0	1 5/16-12	38	22.5	23.0	46	53	38	33	491	16M33R8OMXS	140

Steel, stainless steel and brass Triple-Lok® parts are delivered with NBR elastomeric seals as standard. For more details on other seal materials see page K92.

Order codes shown are part of our current manufacturing programme.

Imperial and metric parts may vary in hexagon dimensions.

$$\frac{\text{PN (bar)}}{10} = \text{PN (MPa)}$$

Do not create drawings from these dimensions, they are subject to change and ISO manufacturing allowances.

RMTX Male stud run tee

Triple-Lok® 37° Flare ends / Male NPTF* thread (SAE 476)

SAE 070424 MS51511

*Stainless Steel = NPT to prevent galling

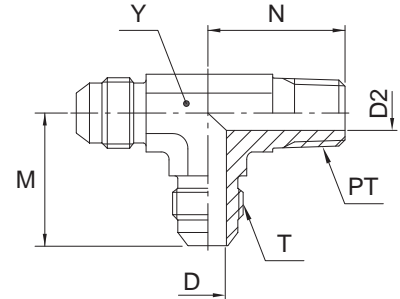

Tube O.D.		Thread NPT/NPTF PT	Thread UN/UNF-2A T	D mm	D2 mm	M mm	N mm	Y mm	Weight (steel) g/1 piece	Triple-Lok® Steel	Triple-Lok® Stainless Steel	Triple-Lok® Brass	PN (bar)	
mm	in.												S	SS
6	3/16	1/8-27	3/8-24	3.2	4.7	21	18	11.0	25	3 RTX-S	3 RTX-SS		420	350
	1/4	1/8-27	7/16-20	4.4	4.7	23	20	11.0	31	4 RTX-S	4 RTX-SS	4 RTX-B	420	350
6	1/4	1/4-18	7/16-20	4.4	7.0	27	28	14.0	49	4-4-4 RTX-S	4-4-4 RTX-SS	4-4-4 RTX-B	420	350
8	5/16	1/8-27	1/2-20	6.0	4.7	24	20	14.0	37	5 RTX-S	5 RTX-SS	5 RTX-B	420	350
	3/8	1/4-18	9/16-18	7.5	7.0	27	28	14.0	57	6 RTX-S	6 RTX-SS	6 RTX-B	420	350
10	3/8	3/8-18	9/16-18	7.5	10.3	29	31	19.0	77	6-6-6 RTX-S	6-6-6 RTX-SS	6-6-6 RTX-B	420	350
12	1/2	3/8-18	3/4-16	9.9	10.3	32	31	19.0	109	8 RTX-S	8 RTX-SS	8 RTX-B	420	350
12	1/2	1/2-14	3/4-16	9.9	13.5	34	37	22.0	163	8-8-8 RTX-S	8-8-8 RTX-SS	8-8-8 RTX-B	420	350
14, 15, 16	5/8	1/2-14	7/8-14	12.3	13.5	37	37	22.0	172	10 RTX-S	10 RTX-SS	10 RTX-B	350	350
	18, 20	3/4	1 1/16-12	15.5	18.3	42	40	27.0	268	12 RTX-S	12 RTX-SS	12 RTX-B	280	280
22	7/8	3/4-14	1 3/16-12	18.3	18.3	46	43	33.3	323	14 RTX-S			280	—
25	1	1-11.5	1 5/16-12	21.4	23.8	46	50	33.3	413	16 RTX-S	16 RTX-SS	16 RTX-B	210	210
28, 30, 32	1 1/4	1 1/4-11.5	1 5/8-12	27.4	31.8	52	60	41.0	681	20 RTX-S	20 RTX-SS	20 RTX-B	170	170
35, 38	1 1/2	1 1/2-11.5	1 7/8-12	33.3	38.0	59	67	47.6	905	24 RTX-S	24 RTX-SS		170	140

Order codes shown are part of our current manufacturing programme.

Imperial and metric parts may vary in hexagon dimensions.

$$\frac{PN \text{ (bar)}}{10} = PN \text{ (MPa)}$$

Pressure ratings – PN shown, apply to Steel and Stainless Steel versions of the product.

For Brass parts reduce pressures by 35 %.

Do not create drawings from these dimensions, they are subject to change and ISO manufacturing allowances.

R3MX Male stud run tee

Triple-Lok® 37° Flare ends / Male BSPT thread (ISO 7)

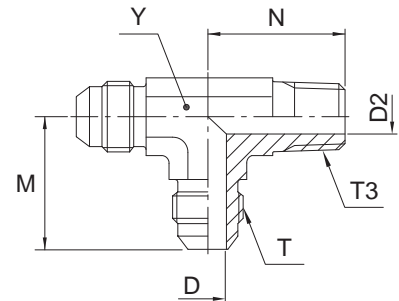

Tube O.D.		Thread BSPT T3	Thread UN/UNF-2A T	D mm	D2 mm	M mm	N mm	Y mm	Weight (steel) g/1 piece	Triple-Lok® Steel	Triple-Lok® Stainless Steel	PN (bar)	
mm	in.											S	SS
6	1/4	1/8-28	7/16-20	4.4	5.0	23	20	11	30	4R3MXS	4R3MXSS	315	315
8	5/16	1/8-28	1/2-20	6.0	5.0	24	20	13	36	5R3MXS	5R3MXSS	315	315
10	3/8	1/4-19	9/16-18	7.5	7.0	27	28	14	55	6R3MXS	6R3MXSS	315	315
12	1/2	3/8-19	3/4-16	9.9	10.0	32	31	19	107	8R3MXS	8R3MXSS	315	315
14, 15, 16	5/8	1/2-14	7/8-14	12.3	13.5	37	37	22	170	10R3MXS	10R3MXSS	315	315

Order codes shown are part of our current manufacturing programme.

Imperial and metric parts may vary in hexagon dimensions.

$$\frac{\text{PN (bar)}}{10} = \text{PN (MPa)}$$

Do not create drawings from these dimensions, they are subject to change and ISO manufacturing allowances.

G4MX Female connector

Triple-Lok® 37° Flare end / Female BSPP thread (ISO 1179-1)

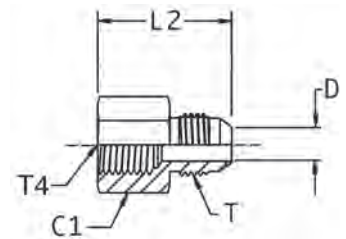

Tube O.D.		Thread BSPP T4	Thread UN/UNF-2A T	C1 mm	D mm	L2 mm	Weight (steel) g/1 piece	Triple-Lok® Steel	Triple-Lok® Stainless Steel	PN (bar)	
mm	in.									S	SS
6	1/4	1/8-28	7/16-20	17	4.4	30	15	4G4MXS	4G4MXSS	315	315
6	1/4	1/4-19	7/16-20	19	4.4	35	42	4-4G4MXS	4-4G4MXSS	400	350
8	5/16	1/8-28	1/2-20	17	6.0	30	22	5G4MXS	5G4MXSS	315	315
8	5/16	1/4-19	1/2-20	19	6.0	35	40	5-4G4MXS	5-4G4MXSS	400	350
10	3/8	1/4-19	9/16-18	19	7.5	36	40	6G4MXS	6G4MXSS	400	350
10	3/8	3/8-19	9/16-18	22	7.5	37	50	6-6G4MXS	6-6G4MXSS	350	350
12	1/2	3/8-19	3/4-16	22	9.9	40	64	8G4MXS	8G4MXSS	350	350
12	1/2	1/2-14	3/4-16	30	9.9	46	116	8-8G4MXS	8-8G4MXSS	400	350
14, 15, 16	5/8	1/2-14	7/8-14	30	12.3	48	121	10G4MXS	10G4MXSS	350	350
18, 20	3/4	3/4-14	1 1/16-12	36	15.5	52	188	12G4MXS	12G4MXSS	315	315
25	1	1 1/11	1 5/16-12	46	21.5	60	340	16G4MXS	16G4MXSS	280	280
28, 30, 32	1 1/4	1 1/4-11	1 5/8-12	50	27.5	63	438	20G4MXS	20G4MXSS	210	210
35, 38	1 1/2	1 1/2-11	1 7/8-12	55	33.0	67	526	24G4MXS	24G4MXSS	140	140

Order codes shown are part of our current manufacturing programme.

Imperial and metric parts may vary in hexagon dimensions.

$$\frac{\text{PN (bar)}}{10} = \text{PN (MPa)}$$

Do not create drawings from these dimensions, they are subject to change and ISO manufacturing allowances.

GMTX Female connector

Triple-Lok® 37° Flare end / Female NPTF* thread (SAE J476)

SAE 070103 MS51503

*Stainless Steel = NPT to prevent galling

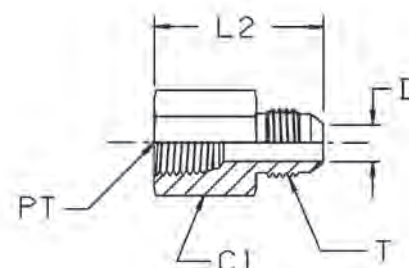

Tube O.D.		Thread NPT/NPTF PT	Thread UN/UNF-2A T	C1 mm	D mm	L2 mm	Weight (steel) g/1 piece	Triple-Lok® Steel	Triple-Lok® Stainless Steel	PN (bar)	
mm	in.									S	SS
2	1/8	1/8-27	5/16-24	14.3	1.6	28.0	18	2 GTX-S		420	
6	1/4	1/8-27	7/16-20	14.3	4.4	30.0	42	4 GTX-S	4GMTXSS	420	350
6	1/4	1/4-18	7/16-20	19.0	4.4	35.0	40	4-4 GTX-S	4-4GMTXSS	420	350
8	5/16	1/8-27	1/2-20	14.3	6.0	30.0	40	5 GTX-S	5GMTXSS	420	350
8	5/16	1/4-18	1/2-20	19.0	6.0	35.5	42	5-4 GTX-S	5-4GMTXSS	420	350
10	3/8	1/4-18	9/16-18	19.0	7.5	36.0	40	6 GTX-S	6GMTXSS	420	350
10	3/8	3/8-18	9/16-18	22.3	7.5	37.0	62	6-6 GTX-S	6-6GMTXSS	420	350
10	3/8	1/2-14	9/16-18	22.3	7.5	43.0	90	6-8 GTX-S	6-8GMTXSS	350	350
12	1/2	3/8-18	3/4-16	22.3	9.9	40.0	45	8 GTX-S	8GMTXSS	420	350
12	1/2	1/4-18	3/4-16	20.6	9.9	36.0	80	8-4 GTX-S	8-4GMTXSS	420	350
12	1/2	1/2-14	3/4-16	28.6	9.9	46.0	116	8-8 GTX-S	8-8GMTXSS	350	350
12	1/2	3/4-14	3/4-16	35.0	9.9	47.0	150	8-12 GTX-S	8-12GMTXSS	280	280
14, 15, 16	5/8	1/2-14	7/8-14	28.6	12.3	48.0	121	10 GTX-S	10GMTXSS	350	350
14, 15, 16	5/8	3/4-14	7/8-14	35.0	12.3	50.0	182	10-12 GTX-S	10-12GMTXSS	280	280
18, 20	3/4	3/4-14	1 1/16-12	35.0	15.5	52.0	188	12 GTX-S	12GMTXSS	280	280
18, 20	3/4	1/2-14	1 1/16-12	28.6	15.5	52.0	133	12-8 GTX-S	12-8GMTXSS	350	350
25	1	1-11.5	1 5/16-12	41.3	21.4	60.0	280	16 GTX-S	16GMTXSS	210	210
28, 30, 32	1 1/4	1 1/4-11.5	1 5/8-12	51.0	27.4	63.0	408	20 GTX-S	20GMTXSS	170	170
35, 38	1 1/2	1 1/2-11.5	1 7/8-12	60.3	33.3	67.0	370	24 GTX-S	24GMTXSS	140	140

Order codes shown are part of our current manufacturing programme.

Imperial and metric parts may vary in hexagon dimensions.

$$\frac{\text{PN (bar)}}{10} = \text{PN (MPa)}$$

Do not create drawings from these dimensions, they are subject to change and ISO manufacturing allowances.

K

WGMTX Female bulkhead connector

Triple-Lok® 37° Flare end / Female NPTF* thread (SAE J476)

*Stainless Steel = NPT to prevent galling

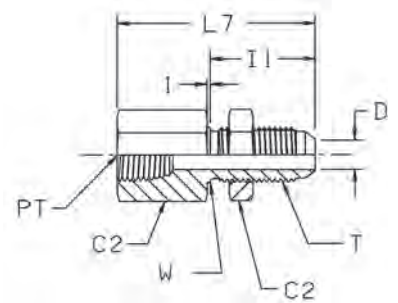

Tube O.D.		Thread NPT/NPTF PT	Thread UN/UNF-2A T	C2 mm	D mm	I1 mm	L7 mm	W mm	Weight (steel) g/1 piece	Triple-Lok®		PN (bar)	
mm	in.									Steel	Stainless Steel	S	SS
6	1/4	1/8-27	7/16-20	17.5	4.4	31	47	11	42	4 WGTX-WLN-S	4WGMTXWLNMS	420	350
6	1/4	1/4-18	7/16-20	19.0	4.4	31	54	11	62	4-4 WGTX-WLN-S	4-4WGMTXWLNMS	420	350
10	3/8	1/4-18	9/16-18	20.6	7.5	33	54	14	72	6 WGTX-WLN-S	6WGMTXWLNMS	420	350
12	1/2	3/8-18	3/4-16	25.4	9.9	37	59	19	117	8 WGTX-WLN-S	8WGMTXWLNMS	420	350
14, 15, 16	5/8	1/2-14	7/8-14	28.6	12.3	41	69	22	179	10 WGTX-WLN-S	10WGMTXWLNMS	350	350
18, 20	3/4	3/4-14	1 1/16-12	35.0	15.5	45	75	27	284	12 WGTX-WLN-S	12WGMTXWLNMS	280	280
25	1	1-11.5	1 5/16-12	41.3	21.4	45	81	33	415	16 WGTX-WLN-S	16WGMTXWLNMS	210	210

Order codes shown are part of our current manufacturing programme.

Imperial and metric parts may vary in hexagon dimensions.

For the version without the locknut remove "WLN" (e.g. 10 WGTX)

$$\frac{PN \text{ (bar)}}{10} = PN \text{ (MPa)}$$

Do not create drawings from these dimensions, they are subject to change and ISO manufacturing allowances.

Maximum bulkhead wallthickness

Size	Tube O.D.		Straight bulkhead union Max. thickness mm	Shape bulkhead union Max. thickness mm
	inch	metric		
4	1/4	6	8.4	5.3
5	5/16	8	8.4	5.3
6	3/8	10	10.7	7.1
8	1/2	12	11.2	8.4
10	5/8	14-16	10.9	8.1
12	3/4	18-20	11.2	8.6
14	7/8		10.4	7.9
16	1	22-25	9.9	7.4
20	1 1/4	28-32	10.2	7.4
24	1 1/2	35-38	7.1	—
32	2		7.1	—

DMTX Female elbow connector

Triple-Lok® 37° Flare end / Female NPTF* thread (SAE J476)

SAE 070203 MS51506

*Stainless Steel = NPT to prevent galling

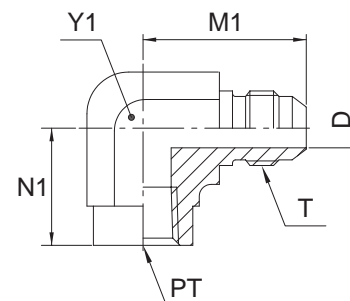

Tube O.D.		Thread NPT/NPTF PT	Thread UN/UNF-2A T	D mm	M1 mm	N1 mm	Y1 mm	Weight (steel) g/1 piece	Triple-Lok® Steel	Triple-Lok® Stainless Steel	Triple-Lok® Brass	PN (bar)	
mm	in.											S	SS
6	1/4	1/8-27	7/16-20	4.4	27	17	14.0	33	4 DTX-S	4 DTX-SS	4 DTX-B	350	350
6	1/4	1/4-18	7/16-20	4.4	31	22	19.0	70	4-4 DTX-S	4-4 DTX-SS	4-4 DTX-B	350	350
8	5/16	1/8-27	1/2-20	6.0	27	17	14.0	33	5 DTX-S	5 DTX-SS	5 DTX-B	350	350
8	5/16	1/4-18	1/2-20	6.0	31	22	19.0	67	5-4 DTX-S	5-4 DTX-SS	5-4 DTX-B	350	350
10	3/8	1/4-18	9/16-18	7.5	31	22	19.0	67	6 DTX-S	6 DTX-SS	6 DTX-B	350	350
10	3/8	1/8-27	9/16-18	7.5	31	17	14.0	39	6-2 DTX-S	6-2 DTX-SS	6-2 DTX-B	350	350
10	3/8	3/8-18	9/16-18	7.5	33	26	22.0	103	6-6 DTX-S	6-6 DTX-SS	6-6 DTX-B	310	310
12	1/2	3/8-18	3/4-16	9.9	36	26	22.0	115	8 DTX-S	8 DTX-SS	8 DTX-B	310	310
12	1/2	1/4-18	3/4-16	9.9	36	26	19.0	190	8-4 DTX-S	8-4 DTX-SS	8-4 DTX-B	350	350
12	1/2	1/2-14	3/4-16	9.9	39	31	27.0	178	8-8 DTX-S	8-8 DTX-SS	8-8 DTX-B	210	210
14, 15, 16	5/8	1/2-14	7/8-14	12.3	42	31	27.0	180	10 DTX-S	10 DTX-SS	10 DTX-B	210	210
18, 20	3/4	3/4-14	1 1/16-12	15.5	48	35	33.3	315	12 DTX-S	12 DTX-SS	12 DTX-B	210	210
18, 20	3/4	1/2-14	1 1/16-12	15.5	48	34	27.0	175	12-8 DTX-S	12-8 DTX-SS	12-8 DTX-B	210	210
22	7/8	3/4-14	1 3/16-12	18.3	47	36	33.3	285	14 DTX-S	14 DTX-SS		125	125
25	1	1-11.5	1 5/16-12	21.4	55	41	41.0	506	16 DTX-S	16 DTX-SS	16 DTX-B	125	125
28, 30, 32	1 1/4	1 1/4-11.5	1 5/8-12	27.4	59	43	47.7	619	20 DTX-S	20 DTX-SS	20 DTX-B	100	100
35, 38	1 1/2	1 1/2-11.5	1 7/8-12	33.3	73	53	64.0	1725	24 DTX-S	24 DTX-SS		100	100

Order codes shown are part of our current manufacturing programme.

Imperial and metric parts may vary in hexagon dimensions.

$$\frac{\text{PN (bar)}}{10} = \text{PN (MPa)}$$

Pressure ratings – PN shown, apply to Steel and Stainless Steel versions of the product.

For Brass parts reduce pressures by 35 %.

Do not create drawings from these dimensions, they are subject to change and ISO manufacturing allowances.

OTX Female branch tee

Triple-Lok® 37° Flare ends / Female NPTF* thread (SAE J476)

SAE 070427 MS51513

*Stainless Steel = NPT to prevent galling

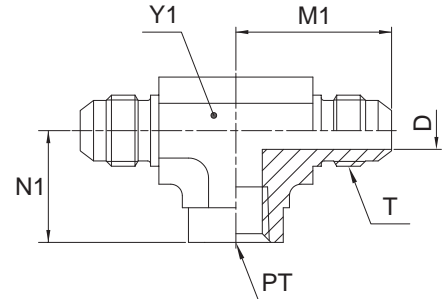

Tube O.D.		Thread NPT/NPTF PT	Thread UN/UNF-2A T	D mm	M1 mm	N1 mm	Y1 mm	Weight (steel) g/1 piece	Triple-Lok® Steel	Triple-Lok® Stainless Steel	Triple-Lok® Brass	PN (bar)	
mm	in.											S	SS
6	1/4	1/8-27	7/16-20	4.4	27	17	14.0	53	4 OTX-S	4 OTX-SS	4 OTX-B	350	350
8	5/16	1/8-27	1/2-20	6.0	27	17	14.0	53	5 OTX-S	5 OTX-SS	5 OTX-B	350	350
10	3/8	1/4-18	9/16-18	7.5	32	22	19.0	98	6 OTX-S	6 OTX-SS	6 OTX-B	350	350
12	1/2	3/8-18	3/4-16	9.9	36	26	22.0	145	8 OTX-S	8 OTX-SS	8 OTX-B	310	310
14, 15, 16	5/8	1/2-14	7/8-14	12.3	42	32	27.0	240	10 OTX-S	10 OTX-SS	10 OTX-B	210	210
18, 20	3/4	3/4-14	1 1/16-12	15.5	48	35	33.3	390	12 OTX-S	12 OTX-SS	12 OTX-B	210	210
25	1	1-11.5	1 5/16-12	21.4	55	41	41.0	745	16 OTX-S	16 OTX-SS	16 OTX-B	125	125
28, 30, 32	1 1/4	1 1/4-11.5	1 5/8-12	27.4	59	43	47.7	930	20 OTX-S	20 OTX-SS		100	100
35, 38	1 1/2	1 1/2-11.5	1 7/8-12	33.3	73	53	64.0	2255	24 OTX-S	24 OTX-SS		100	100

Order codes shown are part of our current manufacturing programme.

Imperial and metric parts may vary in hexagon dimensions.

$$\frac{\text{PN (bar)}}{10} = \text{PN (MPa)}$$

Pressure ratings – PN shown, apply to Steel and Stainless Steel versions of the product.

For Brass parts reduce pressures by 35 %.

Do not create drawings from these dimensions, they are subject to change and ISO manufacturing allowances.

MTX Female run tee

Triple-Lok® 37° Flare ends / Female NPTF* thread (SAE J476)

SAE 070426 MS51514

*Stainless Steel = NPT to prevent galling

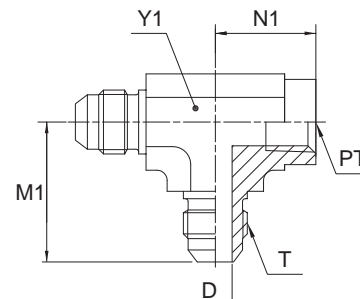

Tube O.D.		Thread NPT/NPTF PT	Thread UN/UNF-2A T	D mm	M1 mm	N1 mm	Y1 mm	Weight (steel) g/1 piece	Triple-Lok® Steel	Triple-Lok® Stainless Steel	Triple-Lok® Brass	PN (bar)	
mm	in.											S	SS
6	1/4	1/8-27	7/16-20	4.4	27	17	14.0	45	4 MTX-S	4 MTX-SS	4 MTX-B	350	350
10	3/8	1/4-18	9/16-18	7.5	32	22	19.0	88	6 MTX-S	6 MTX-SS	6 MTX-B	350	350
12	1/2	3/8-18	3/4-16	9.9	36	26	22.0	125	8 MTX-S	8 MTX-SS	8 MTX-B	310	310
14, 15, 16	5/8	1/2-14	7/8-14	12.3	42	32	27.0	210	10 MTX-S	10 MTX-SS	10 MTX-B	210	210
18, 20	3/4	3/4-14	1 1/16-12	15.5	48	35	33.3	280	12 MTX-S	12 MTX-SS	12 MTX-B	210	210
22	7/8	3/4-14	1 3/16-12	18.3	47	36	33.3	446	14 MTX-S			210	—
25	1	1-11.5	1 5/16-12	21.4	55	41	41.0	620	16 MTX-S	16 MTX-SS		125	125
28, 30, 32	1 1/4	1 1/4-11.5	1 5/8-12	27.4	59	43	47.7	805	20 MTX-S	20 MTX-SS		100	100

Order codes shown are part of our current manufacturing programme.

Imperial and metric parts may vary in hexagon dimensions.

$$\frac{\text{PN (bar)}}{10} = \text{PN (MPa)}$$

Pressure ratings – PN shown, apply to Steel and Stainless Steel versions of the product.

For Brass parts reduce pressures by 35 %.

Do not create drawings from these dimensions, they are subject to change and ISO manufacturing allowances.

G6X Swivel connector

Triple-Lok® 37° Flare female swivel end / Female NPTF* thread (SAE J476)

*Stainless Steel = NPT to prevent galling

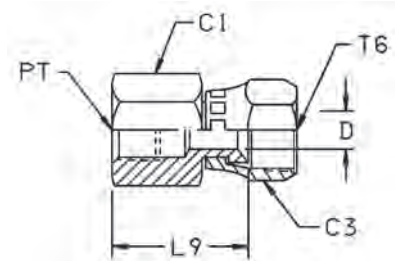

Tube O.D. mm	Tube O.D. in.	Thread NPT/NPTF PT	Thread UN/UNF-2B T6	C1 mm	C3 mm	D mm	L9 mm	Weight (steel) g/1 piece	Triple-Lok® Steel	Triple-Lok® Stainless Steel	PN (bar)	
											S	SS
6	1/4	1/8-27	7/16-20	14.3	14.3	4.4	23	29	4 G6X-S	4 G6X-SS	420	420
6	1/4	1/4-18	7/16-20	19.0	14.3	4.4	27	33	4-4 G6X-S	4-4 G6X-SS	420	420
10	3/8	1/4-18	9/16-18	19.0	17.5	7.5	27	38	6 G6X-S	6 G6X-SS	350	350
10	3/8	3/8-18	9/16-18	22.2	17.5	7.5	29	45	6-6 G6X-S	6-6 G6X-SS	350	350
12	1/2	3/8-18	3/4-16	22.2	22.2	9.9	31	47	8 G6X-S	8 G6X-SS	350	350
12	1/2	1/2-14	3/4-16	28.6	22.2	9.9	38	99	8-8 G6X-S	8-8 G6X-SS	350	350
14, 15, 16	5/8	1/2-14	7/8-14	28.6	25.4	12.3	37	99	10 G6X-S	10 G6X-SS	350	350
18, 20	3/4	3/4-14	1 1/16-12	35.0	31.6	15.5	38	147	12 G6X-S	12 G6X-SS	280	280
25	1	1-11.5	1 5/16-12	41.3	38.0	21.4	47	248	16 G6X-S	16 G6X-SS	210	210
28, 30, 32	1 1/4	1 1/4-11.5	1 5/8-12	51.0	50.8	27.4	55	370	20 G6X-S	20 G6X-SS	170	170
35, 38	1 1/2	1 1/2-11.5	1 7/8-12	60.3	57.2	33.3	57	510	24 G6X-S	24 G6X-SS	140	140

Order codes shown are part of our current manufacturing programme.

Imperial and metric parts may vary in hexagon dimensions.

$$\frac{\text{PN (bar)}}{10} = \text{PN (MPa)}$$

Do not create drawings from these dimensions, they are subject to change and ISO manufacturing allowances.

G4MXMO Pressure gauge connector

Triple-Lok® 37° Flare end / Female BSPP gauge thread (ISO 1179-1)

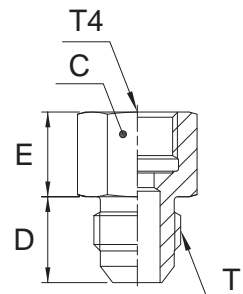

mm	Tube O.D.		Thread BSPP T4	Thread UN/UNF-2A T	D mm	E mm	C mm	Weight (steel) g/1 piece	Triple-Lok® Steel	Triple-Lok® Stainless Steel		PN (bar)	
	in.	S								SS	S	SS	
6	1/4	1/4-19	7/16-20	14	21	19	86	4-4G4MXSMO	4-4G4MXSSMO	350	350	350	350
6	1/4	1/2-14	7/16-20	14	25	27	246	4-8G4MXSMO	4-8G4MXSSMO	315	315	315	315
8	5/16	1/4-19	1/2-20	14	21	19	49	5-4G4MXSMO	5-4G4MXSSMO	350	350	350	350
8	5/16	1/2-14	1/2-20	14	27	27	246	5-8G4MXSMO	5-8G4MXSSMO	315	315	315	315
10	3/8	1/4-19	9/16-20	14	22	19	49	6G4MXSMO	6G4MXSSMO	350	350	350	350
10	3/8	1/2-14	9/16-20	14	29	30	239	6-8G4MXSMO	6-8G4MXSSMO	315	315	315	315
12	1/2	1/4-19	3/4-16	17	22	22	74	8-4G4MXSMO	8-4G4MXSSMO	400	350	400	350
12	1/2	1/2-14	3/4-16	17	28	30	263	8-8G4MXSMO	8-8G4MXSSMO	315	315	315	315

This part requires a copper washer. For more details on other seal materials see page K92.

Order codes shown are part of our current manufacturing programme.

Imperial and metric parts may vary in hexagon dimensions.

$$\frac{\text{PN (bar)}}{10} = \text{PN (MPa)}$$

Do not create drawings from these dimensions, they are subject to change and ISO manufacturing allowances.

K

TT4MX Test point connector

Triple-Lok® 37° Flare female end / Female BSPP thread (ISO 1179-1) for EMA3 test point

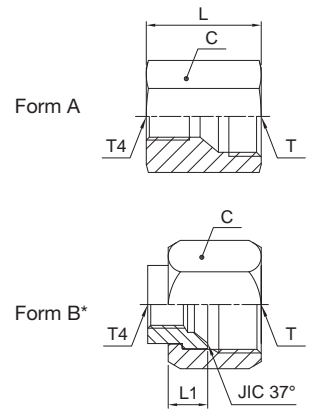

* Form B has to be assembled with a nut BMTX / BTX (to be ordered separately).

Tube O.D. T		Thread BSPP T4	Thread UN/UNF-2B T	Form	L mm	L1 mm	C mm	Weight (steel) g/1 piece	Triple-Lok® Steel	Triple-Lok® Stainless Steel	PN (bar)	
mm	in.										S	SS
6	1/4	1/4-19	7/16-20	A	29	-	19	42	4TT4MXS	4TT4MXSS	400	350
8	5/16	1/4-19	1/2-20	A	29	-	19	46	5TT4MXS	5TT4MXSS	400	350
10	3/8	1/4-19	9/16-18	A	29	-	19	43	6TT4MXS	6TT4MXSS	400	350
12	1/2	1/4-19	3/4-16	A	32	-	22	62	8TT4MXS	8TT4MXSS	400	350
14, 15, 16	5/8	1/4-19	7/8-14	A	32	-	27	102	10TT4MXS	10TT4MXSS	350	350
18, 20	3/4	1/4-19	1 1/16-12	B	-	11	32	42	12TT4XS	12TT4XSS	350	350
25	1	1/4-19	1 5/16-12	B	-	12	41	56	16TT4XS	16TT4XSS	280	280
28, 30, 32	1 1/4	1/4-19	1 5/8-12	B	-	15	50	98	20TT4XS	20TT4XSS	280	210
35, 38	1 1/2	1/4-19	1 7/8-12	B	-	17	60	185	24TT4XS	24TT4XSS	210	210

Order codes shown are part of our current manufacturing programme.

Imperial and metric parts may vary in hexagon dimensions.

$$\frac{\text{PN (bar)}}{10} = \text{PN (MPa)}$$

Do not create drawings from these dimensions, they are subject to change and ISO manufacturing allowances.

TTP4MX Test point connection

Triple-Lok® 37° Flare female end / EMA3 test point

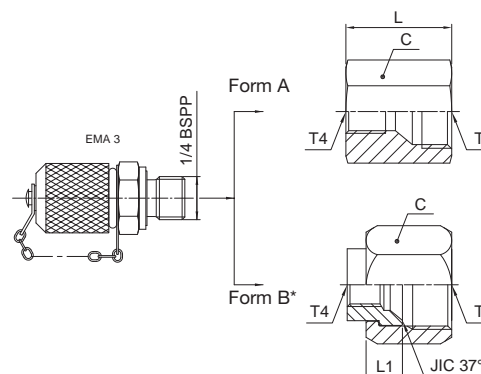

* Form B versions delivered complete with BMTXS nut.

Tube O.D. T		Thread BSPP T4	Thread UN/UNF-2B T	Form	L mm	L1 mm	C mm	Weight (steel) g/1 piece	Triple-Lok® Steel	PN (bar)
mm	in.									
6	1/4	1/4-19	7/16-20	A	29	–	19	132	4TTP4MXS	400
8	5/16	1/4-19	1/2-20	A	29	–	19	136	5TTP4MXS	400
10	3/8	1/4-19	9/16-18	A	29	–	19	133	6TTP4MXS	400
12	1/2	1/4-19	3/4-16	A	32	–	22	152	8TTP4MXS	400
14, 15, 16	5/8	1/4-19	7/8-14	A	32	–	27	192	10TTP4MXS	350
18, 20	3/4	1/4-19	1 1/16-12	B	–	11	32	132	12TTP4XS	350
25	1	1/4-19	1 5/16-12	B	–	12	41	146	16TTP4XS	280
28, 30, 32	1 1/4	1/4-19	1 5/8-12	B	–	15	50	188	20TTP4XS	280
35, 38	1 1/2	1/4-19	1 7/8-12	B	–	17	60	275	24TTP4XS	210

Order codes shown are part of our current manufacturing programme.

Imperial and metric parts may vary in hexagon dimensions.

$$\frac{\text{PN (bar)}}{10} = \text{PN (MPa)}$$

Do not create drawings from these dimensions, they are subject to change and ISO manufacturing allowances.

R604MX Test point connector

Male / Female swivel Triple-Lok® 37° flare end / Female BSPP thread (ISO 1179-1)

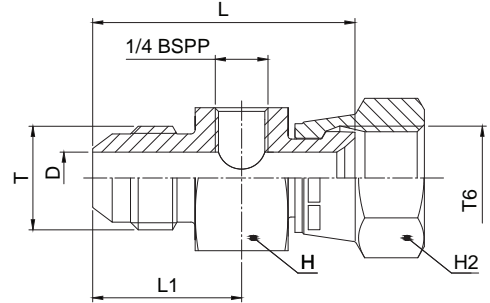

Tube O.D. T		Thread UN/UNF-2A T	Thread UN/UNF-2B T6	D mm	L mm	L1 mm	H mm	H2 mm	Weight (steel) g/1 piece	Triple-Lok® Steel	PN (bar)
6	1/4	7/16-20	7/16-20	4.4	45	26	36	14	180	4-4R604MXS	500
8	5/16	1/2-20	1/2-20	6.0	46	26	36	17	200	5-4R604MXS	420
10	3/8	9/16-18	9/16-18	7.5	47	26	36	19	210	6-4R604MXS	350
12	1/2	3/4-16	3/4-16	9.9	50	28	36	22	218	8-4R604MXS	350
14, 15, 16	5/8	7/8-14	7/8-14	12.3	54	31	36	27	247	10-4R604MXS	350
18, 20	3/4	1 1/16-12	1 1/16-12	15.5	56	34	41	32	326	12-4R604MXS	350
25	1	1 5/16-12	1 5/16-12	21.4	60	35	46	38	416	16-4R604MXS	250
28, 30, 32	1 1/4	1 5/8-12	1 5/8-12	27.4	64	36	50	50	601	20-4R604MXS	250
35, 38	1 1/2	1 7/8-12	1 7/8-12	33.3	69	39	60	60	905	24-4R604MXS	170

Order codes shown are part of our current manufacturing programme.

Imperial and metric parts may vary in hexagon dimensions.

$$\frac{\text{PN (bar)}}{10} = \text{PN (MPa)}$$

Do not create drawings from these dimensions, they are subject to change and ISO manufacturing allowances.

R6P4MX Test point connector

Male / Female swivel Triple-Lok® 37° flare end / EMA3 test point

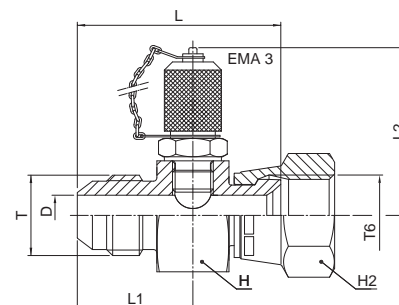

Tube O.D. T		Thread UN/UNF-2A T	Thread UN/UNF-2B T6	D mm	L mm	L1 mm	L2 mm	H mm	H2 mm	Weight (steel) g/1 piece	Triple-Lok® Steel	PN (bar)
6	1/4	7/16-20	7/16-20	4.4	45	26	54	36	14	270	4-4R6P4MXS	500
8	5/16	1/2-20	1/2-20	6.0	46	26	54	36	17	290	5-4R6P4MXS	420
10	3/8	9/16-18	9/16-18	7.5	47	26	54	36	19	300	6-4R6P4MXS	350
12	1/2	3/4-16	3/4-16	9.9	50	28	54	36	22	308	8-4R6P4MXS	350
14, 15, 16	5/8	7/8-14	7/8-14	12.3	54	31	54	36	27	337	10-4R6P4MXS	350
18, 20	3/4	1 1/16-12	1 1/16-12	15.5	56	34	54	41	32	416	12-4R6P4MXS	350
25	1	1 5/16-12	1 5/16-12	21.4	60	35	54	46	38	506	16-4R6P4MXS	250
28, 30, 32	1 1/4	1 5/8-12	1 5/8-12	27.4	64	36	54	50	50	691	20-4R6P4MXS	250
35, 38	1 1/2	1 7/8-12	1 7/8-12	33.3	69	39	54	60	60	995	24-4R6P4MXS	170

Order codes shown are part of our current manufacturing programme.

Imperial and metric parts may vary in hexagon dimensions.

$$\frac{\text{PN (bar)}}{10} = \text{PN (MPa)}$$

Do not create drawings from these dimensions, they are subject to change and ISO manufacturing allowances.

K6004MX Test point connector

Male / Female swivel Triple-Lok® 37° flare end / 2 BSPP female threads

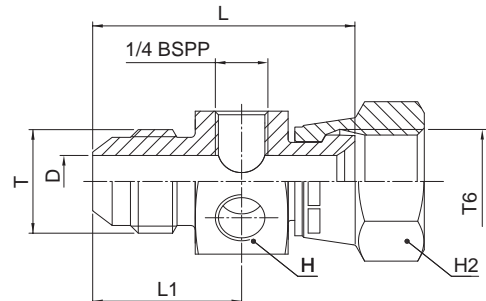

Tube O.D. T		Thread UN/UNF-2A T	Thread UN/UNF-2B T6	D mm	L mm	L1 mm	H mm	H2 mm	Weight (steel) g/1 piece	Triple-Lok® Steel	PN (bar)
6	1/4	7/16-20	7/16-20	4.4	45	26	36	14	170	4-4K6004MXS	500
8	5/16	1/2-20	1/2-20	6.0	46	26	36	17	190	5-4K6004MXS	420
10	3/8	9/16-18	9/16-18	7.5	47	26	36	19	200	6-4K6004MXS	350
12	1/2	3/4-16	3/4-16	9.9	50	28	36	22	208	8-4K6004MXS	350
14, 15, 16	5/8	7/8-14	7/8-14	12.3	54	31	36	27	237	10-4K6004MXS	350
18, 20	3/4	1 1/16-12	1 1/16-12	15.5	56	34	41	32	316	12-4K6004MXS	350
25	1	1 5/16-12	1 5/16-12	21.4	60	35	46	38	406	16-4K6004MXS	250

Order codes shown are part of our current manufacturing programme.

Imperial and metric parts may vary in hexagon dimensions.

$$\frac{\text{PN (bar)}}{10} = \text{PN (MPa)}$$

Do not create drawings from these dimensions, they are subject to change and ISO manufacturing allowances.

K6PP4MX Test point connector

Male / female swivel Triple-Lok® 37° flare end / EMA3 test point & blanking plug

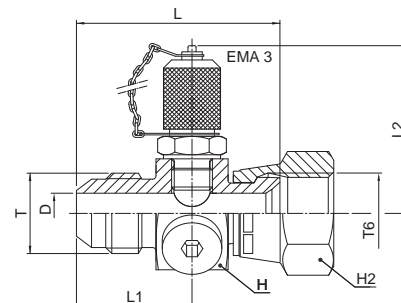

Tube O.D. T		Thread UN/UNF-2A T	Thread UN/UNF-2B T6	D	L	L1	L2	H	H2	Weight (steel) g/1 piece	Triple-Lok® Steel	PN (bar)
mm	in.			mm	mm	mm	mm	mm	mm			
6	1/4	7/16-20	7/16-20	4.4	45	26	54	36	14	270	4-4K6PP4MXS	500
8	5/16	1/2-20	1/2-20	6.0	46	26	54	36	17	290	5-4K6PP4MXS	420
10	3/8	9/16-18	9/16-20	7.5	47	26	54	36	19	300	6-4K6PP4MXS	350
12	1/2	3/4-16	3/4-16	9.9	50	28	54	36	22	308	8-4K6PP4MXS	350
14, 15, 16	5/8	7/8-14	7/8-14	12.3	54	31	54	36	27	337	10-4K6PP4MXS	350
18, 20	3/4	1 1/16-12	1 1/16-12	15.5	56	34	54	41	32	416	12-4K6PP4MXS	350
25	1	1 5/16-12	1 5/16-12	21.4	60	35	54	46	38	506	16-4K6PP4MXS	250

Order codes shown are part of our current manufacturing programme.

Imperial and metric parts may vary in hexagon dimensions.

$$\frac{\text{PN (bar)}}{10} = \text{PN (MPa)}$$

Do not create drawings from these dimensions, they are subject to change and ISO manufacturing allowances.

K

FNMTX Cap

Triple-Lok® 37° Flare female swivel cap end
SAE 070112 MS51532

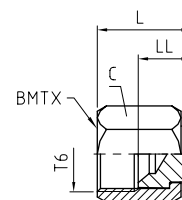

Tube O.D. mm	in.	Thread UN/UNF-2B T6	C mm	LL mm	L mm	Weight (steel) g/1 piece	Triple-Lok® Steel	Triple-Lok® Stainless Steel	Triple-Lok® Brass	PN (bar)	
										S	SS
6	1/8	5/16-24	9.5	10	15	10	2 FNTX-S			500	—
	3/16	3/8-24	11.0	10	17	11	3 FNTX-S			500	—
	1/4	7/16-20	14.0	9	17	14	4FNMTXS	4FNMTXSS	4 FNTX-B	500	350
	5/16	1/2-20	17.0	10	19	19	5FNMTXS	5FNMTXSS	5 FNTX-B	420	350
10	3/8	9/16-18	19.0	12	21	31	6FNMTXS	6FNMTXSS	6 FNTX-B	420	350
14, 15, 16	1/2	3/4-16	22.0	14	23	45	8FNMTXS	8FNMTXSS	8 FNTX-B	420	350
	5/8	7/8-14	27.0	14	27	75	10FNMTXS	10FNMTXSS	10 FNTX-B	350	350
	3/4	1 1/16-12	32.0	17	30	114	12FNMTXS	12FNMTXSS	12 FNTX-B	350	350
	7/8	1 3/16-12	35.0	16	32	133	14 FNTX-S	14FNMTXSS	14 FNTX-B	310	280
	1	1 5/16-12	41.0	16	33	200	16FNMTXS	16FNMTXSS	16 FNTX-B	310	280
28, 30, 32	1 1/4	1 5/8-12	50.0	19	37	272	20FNMTXS	20FNMTXSS	20 FNTX-B	280	210
	1 1/2	1 7/8-12	60.0	24	45	553	24FNMTXS	24FNMTXSS	24 FNTX-B	210	140
		2	2 1/2-12	73.0	28	52	930	32 FNTX-S			140

Order codes shown are part of our current manufacturing programme.

Imperial and metric parts may vary in hexagon dimensions.

$$\frac{\text{PN (bar)}}{10} = \text{PN (MPa)}$$

Pressure ratings – PN shown, apply to Steel and Stainless Steel versions of the product.

For Brass parts reduce pressures by 35 %.

Do not create drawings from these dimensions, they are subject to change and ISO manufacturing allowances.

PNMTX Plug

Triple-Lok® 37° Flare end plug
SAE 070109 MS51518

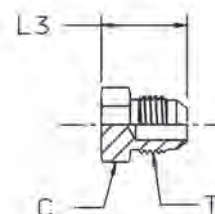

Tube O.D. mm	Tube O.D. in.	Thread UN/UNF-2A T	C mm	L mm	Weight (steel) g/1 piece	Triple-Lok® Steel	Triple-Lok® Stainless Steel	PN (bar)	
								S	SS
6	1/8	5/16-24	11.00	18	9	2 PNTX-S		500	—
	3/16	3/8-24	11.00	19	10	3 PNTX-S		500	—
	1/4	7/16-20	13.00	21	10	4PNMTXS	4PNMTXSS	500	350
	5/16	1/2-20	14.00	21	14	5PNMTXS	5PNMTXSS	420	350
8	3/8	9/16-18	16.00	21	19	6 PNTX-S	6PNMTXSS	420	350
14, 15, 16	1/2	3/4-16	19.00	24	39	8PNMTXS	8PNMTXSS	420	350
	5/8	7/8-14	24.00	28	60	10PNMTXS	10PNMTXSS	350	350
18, 20	3/4	1 1/16-12	27.00	33	93	12PNMTXS	12PNMTXSS	350	350
	7/8	1 3/16-12	31.75	33	95	14 PNTX-S	14PNMTXSS	280	280
22	1	1 5/16-12	35.00	34	98	16 PNTX-S	16PNMTXSS	280	280
	1 1/4	1 5/8-12	42.80	37	269	20 PNTX-S	20PNMTXSS	280	210
28, 30, 32	1 1/2	1 7/8-12	51.00	42	360	24 PNTX-S	24PNMTXSS	210	140
	2	2 1/2-12	66.60	52	470	32 PNTX-S		140	—

Order codes shown are part of our current manufacturing programme.

Imperial and metric parts may vary in hexagon dimensions.

$$\frac{\text{PN (bar)}}{10} = \text{PN (MPa)}$$

Do not create drawings from these dimensions, they are subject to change and ISO manufacturing allowances.

K

XHMLO Conversion union

Triple-Lok® 37° Flare End / O-Lok ORFS end

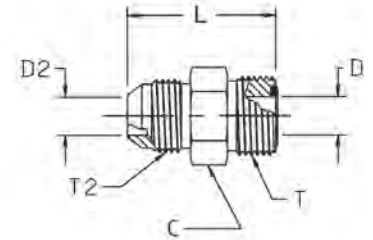

Tube O.D. T2/T		Thread UN/UNF-2A T2	Thread UN/UNF-2A T	D mm	D2 mm	L mm	C mm	Weight (steel) g/1 piece	Triple-Lok® Steel	Triple-Lok® Stainless Steel	PN (bar)	
mm	in.										S	SS
6	1/4	7/16-20	9/16-18	4.4	4.4	32	16.00	29	4 XHLO-S	4XHMLOSS	500	350
8, 10	5/16, 3/8	9/16-18	11/16-16	6.7	6.7	34	19.00	45	6 XHLO-S	6XHMLOSS	420	350
12	1/2	3/4-16	13/16-16	9.6	10.0	39	22.20	70	8 XHLO-S	8XHMLOSS	420	350
14, 15, 16	5/8	7/8-14	1-14	12.3	12.3	46	27.00	119	10 XHLO-S	10XHMLOSS	350	350
18, 20	3/4	1 1/16-12	1 3/16-12	15.5	15.5	52	31.75	181	12 XHLO-S	12XHMLOSS	350	350
22, 25	1	1 5/16-12	1 7/16-12	20.5	20.5	55	38.00	265	16 XHLO-S	16XHMLOSS	280	280
28, 30, 32	1 1/4	1 5/8-12	1 11/16-12	26.0	26.0	58	44.45	383	20 XHLO-S	20XHMLOSS	280	210
35, 38	1 1/2	1 7/8-12	2-12	32.0	32.0	63	54.00	562	24 XHLO-S	24XHMLOSS	210	140

Steel, stainless steel and brass Triple-Lok® parts are delivered with NBR elastomeric seals as standard. For more details on other seal materials see page K92.

Order codes shown are part of our current manufacturing programme.

Imperial and metric parts may vary in hexagon dimensions.

$$\frac{\text{PN (bar)}}{10} = \text{PN (MPa)}$$

Do not create drawings from these dimensions, they are subject to change and ISO manufacturing allowances.

XHML6 Conversion swivel nut connector

Triple-Lok® 37° Flare end / O-Lok ORFS female swivel end

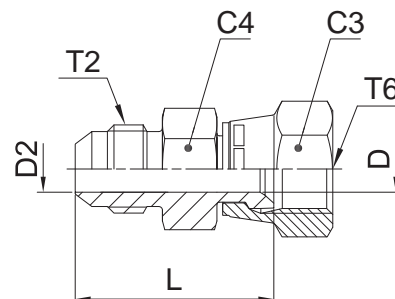

Tube O.D. T2/T6		Thread UN/UNF-2A T2	Thread UN/UNF-2B T6	C3	D	D2	L	C4	Weight (steel) g/1 piece	Triple-Lok® Steel	Triple-Lok® Stainless Steel	PN (bar)	
mm	in.			mm	mm	mm	mm	mm				S	SS
6	1/4	7/16-20	9/16-18	17.5	4.2	4.2	38	16.0	29	4 XHL6-S	4XHML6SS	500	350
8, 10	5/16, 3/8	9/16-18	11/16-16	20.6	6.7	6.7	41	19.0	46	6 XHL6-S	6XHML6SS	420	350
12	1/2	3/4-16	13/16-16	23.8	9.0	9.0	48	22.2	73	8 XHL6-S	8XHML6SS	420	350
14, 15, 16	5/8	7/8-14	1-14	28.6	11.5	11.5	56	27.0	126	10 XHL6-S	10XHML6SS	350	350
18, 20	3/4	1 1/16-12	1 3/16-12	35.0	14.0	14.0	64	31.8	205	12 XHL6-S	12XHML6SS	350	350
22, 25	1	1 5/16-12	1 7/16-12	41.3	19.8	19.8	68	38.0	285	16 XHL6-S	16XHML6SS	280	280
28, 30, 32	1 1/4	1 5/8-12	1 11/16-12	47.6	26.0	26.0	71	43.0	360	20 XHL6-S	20XHML6SS	280	280

Order codes shown are part of our current manufacturing programme.

Imperial and metric parts may vary in hexagon dimensions.

$$\frac{\text{PN (bar)}}{10} = \text{PN (MPa)}$$

Do not create drawings from these dimensions, they are subject to change and ISO manufacturing allowances.

K

LOHMX6 Conversion swivel nut connector

Triple-Lok® 37° Flare female swivel end / O-Lok ORFS end

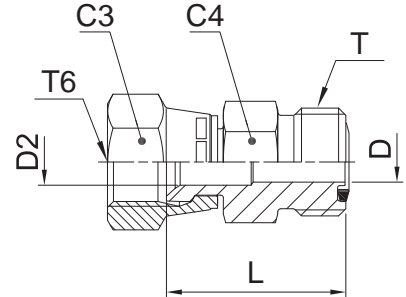

Tube O.D. T6/T		Thread UN/UNF-2B T6	Thread UN/UNF-2A T	C3	D	D2	C4	L	Weight (steel) g/1 piece	Triple-Lok® Steel	Triple-Lok® Stainless Steel	PN (bar)	
mm	in.			mm	mm	mm	mm	mm				S	SS
6	1/4	7/16-20	9/16-18	14.3	4.4	4.4	16	24.0	26	4 LOHX6-S	4LOHMX6SS	500	350
8, 10	5/16, 3/8	9/16-18	11/16-16	17.5	6.7	6.7	19	30.0	40	6 LOHX6-S	6LOHMX6SS	350	350
12	1/2	3/4-16	13/16-16	22.2	9.5	9.5	22	34.0	63	8 LOHX6-S	8LOHMX6SS	350	350
14, 15, 16	5/8	7/8-14	1-14	25.4	12.3	12.3	27	39.0	103	10 LOHX6-S	10LOHMX6SS	350	350
18, 20	3/4	1 1/16-12	1 3/16-12	31.8	15.5	15.5	32	31.8	162	12 LOHX6-S	12LOHMX6SS	350	350
22, 25	1	1 5/16-12	1 7/16-12	38.0	20.5	20.5	38	46.0	229	16 LOHX6-S	16LOHMX6SS	250	250

Steel, stainless steel and brass Triple-Lok® parts are delivered with NBR elastomeric seals as standard. For more details on other seal materials see page K92.

Order codes shown are part of our current manufacturing programme.

Imperial and metric parts may vary in hexagon dimensions.

$$\frac{\text{PN (bar)}}{10} = \text{PN (MPa)}$$

Do not create drawings from these dimensions, they are subject to change and ISO manufacturing allowances.

WLNM Bulkhead locknut

Bulkhead fitting locknut
SAE 080118 MS51860

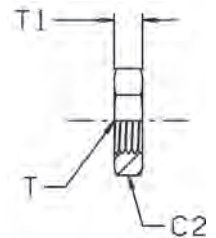

Thread UN/UNF-2B T	C2 mm	T1 mm	Weight (steel) g/1 piece	Triple-Lok® Steel	Triple-Lok® Stainless Steel	Triple-Lok® Brass
3/8-24	17	6	9	3 WLN-S		
7/16-20	17	7	9	4WLNMS	4WLNMS	4WLNMB
1/2-20	19	7	9	5WLNMS	5WLNMS	5WLNMB
9/16-18	22	7	11	6WLNMS	6WLNMS	6WLNMB
3/4-16	24	8	18	8WLNMS	8WLNMS	8WLNMB
7/8-14	30	9	24	10WLNMS	10WLNMS	10WLNMB
1 1/16-12	36	10	42	12WLNMS	12WLNMS	12WLNMB
1 3/16-12	38	10	45	14 WLN-S	14WLNMS	14WLNMB
1 5/16-12	41	10	49	16WLNMS	16WLNMS	16WLNMB
1 5/8-12	50	10	50	20WLNMS	20WLNMS	20WLNMB
1 7/8-12	55	10	68	24WLNMS	24WLNMS	24WLNMB
2 1/2-12	70	10	80	32 WLN-S		

Order codes shown are part of our current manufacturing programme.

Imperial and metric parts may vary in hexagon dimensions.

Do not create drawings from these dimensions, they are subject to change and ISO manufacturing allowances.

Spare parts guide – Triple-Lok® retaining rings and seals

BSPB male threads – ISO 1179

BSPB Thread	ED seal Order code		O-ring order code*		O-ring ID × section mm	Retainer ring Order code Steel	Retainer ring Order code Stainless Steel	Copper washer Order code
	NBR	FKM	NBR	FKM				
1/8	ED10X1X	ED10X1VITX	6-002-N552-9	6-002-V894-9	8.00 × 2.00	8207-1/8	8207SS1/8	-
1/4	ED14X1.5X	ED14X1.5VITX	2-111-N552-9	2-111-V894-9	10.77 × 2.62	8207-1/4	8207SS1/4A	M25180
3/8	ED3/8X	ED3/8VITX	2-113-N552-9	2-113-V894-9	13.94 × 2.62	8207-3/8	8207SS3/8A	-
1/2	ED1/2X	ED1/2VITX	5-256-N552-9	5-256-V894-9	17.96 × 2.62	8207-1/2	8207SS1/2	M25182
3/4	ED26X1.5X	ED26X1.5VITX	2-119-N552-9	2-119-V894-9	23.47 × 2.62	8207-3/4	8207SS3/4	-
1	ED33X2X	ED33X2VITX	2-217-N552-9	2-217-V894-9	29.74 × 3.53	8207-1	8207SS1A	-
1 1/4	ED42X2X	ED42X2VITX	2-222-N552-9	2-222-V894-9	37.69 × 3.53	8207-1-1/4	8207SS1 1/4	-
1 1/2	ED48X2X	ED48X2VITX	2-224-N552-9	2-224-V894-9	44.04 × 3.53	8207-1-1/2	8207SS1 1/2	-

Typical fittings using these parts: F42EDMX / F4OMX / C4OMX / V4OMX etc.

* Must be used with correct retainer ring

Metric male threads – ISO 9974

Metric Thread	ED seal order code		O-ring Order code*		O-ring ID × section mm	Retainer ring Order code Steel	Retainer ring Order code Stainless Steel
	NBR	FKM	NBR	FKM			
M 10×1.0	ED10X1X	ED10X1VITX	6-074-N552-9	6-074-V894-9	8.00 × 1.50	M10RR	RRM10X1SS
M 12×1.5	ED12X1.5X	ED12x1.5VITX	2-012-N552-9	2-012-V894-9	9.25 × 1.78	M12RR	RRM12X1.5SS
M 14×1.5	ED14X1.5X	ED14X1.5VITX	2-013-N552-9	2-013-V894-9	10.82 × 1.78	M14RR	RRM14X1.5SS
M 16×1.5	ED16X1.5X	ED16X1.5VITX	3-907-N552-9	3-907-V894-9	13.46 × 2.08	M16RR	RRM16X1.5SS
M 18×1.5	ED18X1.5X	ED18X1.5VITX	2-114-N552-9	2-114-V894-9	15.54 × 2.62	M18RR	RRM18X1.5SS
M 22×2.0	ED22X1.5X	ED22X1.5VITX	2-018-N552-9	2-018-V894-9	18.77 × 1.78	M22RR	RRM22X1.5SS
M 27×2.0	ED26X1.5X**	ED26X1.5VITX	2-119-N552-9	2-119-V894-9	23.47 × 2.62	M27RR	RRM27X2SS
M 33×2.0	ED33X2X	ED33X2VITX	2-122-N552-9	2-122-V894-9	28.24 × 2.62	M33RR	RRM33X2SS
M 42×2.0	ED42X2X	ED42X2VITX	2-128-N552-9	2-128-V894-9	37.77 × 2.62	M42RR	RRM42X2SS
M 48×2.0	ED48X2X	ED48X2VITX	2-132-N552-9	2-132-V894-9	44.12 × 2.62	M48RR	RRM48X2SS

Typical fittings using these parts: F82EDMX / F8OMX / C8OMX / V8OMX etc.

* Must be used with correct retainer ring

** Same seal used for M 26×1.5 and M 27×2.0 Threads

UN / UNF male threads – ISO 11926

UN / UNF Thread	Dash size	O-ring Order code		O-Ring ID × section (mm)
		NBR	FKM	
5/16-24	2	3-902-N552-9	3-902-V894-9	6.07 × 1.63
3/8-24	3	3-903-N552-9	3-903-V894-9	7.65 × 1.63
7/16-20	4	3-904-N552-9	3-904-V894-9	8.92 × 1.83
1/2-20	5	3-905-N552-9	3-905-V894-9	10.52 × 1.83
9/16-18	6	3-906-N552-9	3-906-V894-9	11.89 × 1.98
3/4-16	8	3-908-N552-9	3-908-V894-9	16.36 × 2.21
7/8-14	10	3-910-N552-9	3-910-V894-9	19.18 × 2.46
1 1/16-12	12	3-912-N552-9	3-912-V894-9	23.47 × 2.95
1 3/16-12	14	3-914-N552-9	3-914-V894-9	26.59 × 2.95
1 5/16-12	16	3-916-N552-9	3-916-V894-9	29.74 × 2.95
1 5/8-12	20	3-920-N552-9	3-920-V894-9	37.47 × 3.00
1 7/8-12	24	3-924-N552-9	3-924-V894-9	43.69 × 3.00
2 1/2-12	32	3-932-N552-9	3-932-V894-9	59.36 × 3.00

Typical fittings using these parts: F5OMX / C5OMX / R5OMX etc.

Metric male threads – ISO 6149

Metric Thread	O-ring Order code		O-Ring ID × section (mm)
	NBR	FKM	
M 10×1.0	6-345-N552-9	6-345-V894-9	8.20 × 1.50
M 12×1.5	6-346-N552-9	6-346-V894-9	9.40 × 2.10
M 14×1.5	6-347-N552-9	6-347-V894-9	11.40 × 2.10
M 16×1.5	6-348-N552-9	6-348-V894-9	13.40 × 2.10
M 18×1.5	6-349-N552-9	6-349-V894-9	15.40 × 2.10
M 22×1.5	6-350-N552-9	6-350-V894-9	19.40 × 2.10
M 27×2.0	6-351-N552-9	6-351-V894-9	23.70 × 2.80
M 33×2.0	6-352-N552-9	6-352-V894-9	29.70 × 2.80
M 42×2.0	6-353-N552-9	6-353-V894-9	38.70 × 2.80
M 48×2.0	6-354-N552-9	6-354-V894-9	46.70 × 2.80

Typical fittings using these parts: F87OMX / S87OMX etc.

Other seal compounds available on request for alternative applications







Ferulok[®] Flareless

Bite Type Fittings

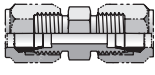
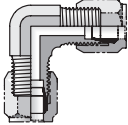
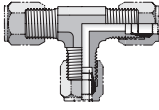
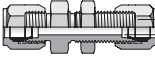
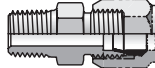
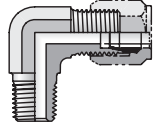
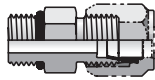
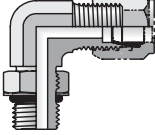
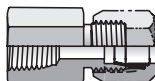
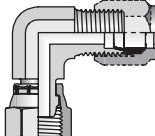
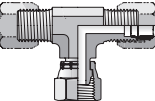
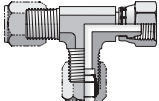

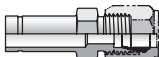
Visual index

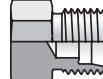
<p>Tube-Tube</p>	 HBU p. L6	 EBU p. L6	 JBU p. L7		
<p>Bulkhead unions</p>	 WBU p. L7				
<p>Tube to male NPTF</p>	 FBU p. L11	 CBU p. L12			
<p>Tube to straight thread UNF</p>	 F5BU p. L10	 C5BU p. L12			
<p>Tube to female NPTF</p>	 GBU p. L13				
<p>Tube to Flareless Swivel</p>	 C6BU p. L8	 S6BU p. L8	 R6BU p. L9		
<p>Nuts & Sleeves Reducers, Caps & Plugs</p>	 BU p. L5	 TU p. L5	 TRBU p. L9	 FNU p. L13	 PNU p. L14

How to order Ferulok® fittings

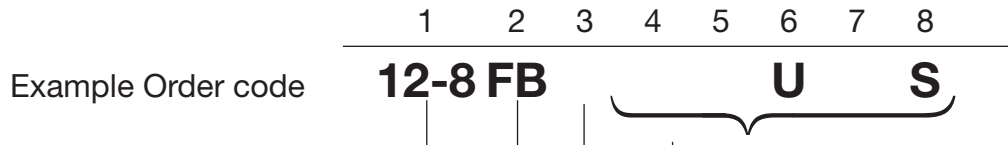

1 Order codes for tube and port thread ends

Dash Size	Tube Size (inch)	Tube Size (mm)	Port Thread Size (inch) BSPP/BSPT/NPT	Port Thread Size UN / UNF
4	1/4	6	1/4	7/16-20
5				1/2-20
6	3/8	8,10	3/8	9/16-18
8	1/2	12	1/2	3/4-16
10	5/8	14,15,16	5/8	7/8-14
12	3/4	18,20	3/4	1 1/6-12
14				1 3/6-12
16	1	25	1	1 5/6-12
20	1 1/4	28,30,32	1 1/4	1 5/8-12
24	1 1/2	35,38	1 1/2	1 7/8-12
32	2	50	2	2 1/2-12

Example:
stud adaptor with nut and ferrule - 3/4" tube to 1/2" NPT port 12-8 FB-U-S

3 Threads and sealing methods

Code	Description
None	NPT/NPTF Thread
3	BSPT Thread
4	BSPP Thread O-Ring & Retainer Ring
42	BSPP Thread EOLASTIC seal 'ED'
5	UN/UNF Thread (O-Ring Seal)
8	Metric Thread O-Ring & Retainer Ring
82	Metric Thread EOLASTIC seal 'ED'
87	Metric ISO 6149 Thread (O-Ring Seal)
63	Swivel Connector BSPT end
64	Swivel Connector BSPP end (O-Ring & Retainer Ring)
642	Swivel Connector BSPP end (EOLASTIC Seal 'ED')
65	Swivel Connector UN/UNF end (O-Ring seal)
68	Swivel Connector Metric end (O-Ring & Retainer Ring)
682	Swivel Connector Metric end (EOLASTIC Seal 'ED')
687	Swivel Connector Metric ISO 6149 end

2 Codes for fitting styles/shapes

Code	Description
AE6	Straight Thread Swivel
B	Nut
C	Male Stud elbow
CC	Extended Male Stud elbow
C6	Swivel Nut Elbow
E	Union elbow
F	Male Stud connector
FF	Extended Male Stud connector
F6	Male Stud Swivel
FN	Cap
FNLBAS	Bleed Adapter Cap
G	Female Connector
H	Straight union
H6	Swivel/Swivel Adapter
J	Union Tee
K	Union Cross
LOHB3	Braze Adapter
LOHX6	Triple-Lok® Swivel/O-Lok® adaptor
M	Female Run Tee
O	Female Branch Tee
PN	Plug
PNLOBA	Bleed Adapter Plug
R	Male Stud Run Tee
R6	Swivel Run Tee
S	Male Stud Branch Tee
S6	Swivel Branch Tee
SBR	Braze Ring
TPL	Parflange® sleeve
TL	Brazed sleeve
TR	Tube End Reducer
TT	Test Point Adapter
TW3	Weld Nipple
V	45° male stud elbow
V6	Swivel Nut 45° Elbow
W	Bulkhead Union
WE	Bulkhead Union Elbow
WJJ	Bulkhead Run Tee
WJT	Bulkhead Branch Tee
WLNML	Bulkhead Locknut
WN	Bulkhead 45° union elbow
XHL6	Triple Lok®/Swivel O-Lok® adaptor
XHLO	Triple Lok®/O-Lok® male adaptor

4 Stud connector seal

Code	Description
O	O-Ring Seal (Assembled on fitting)
ED	Captive EOLASTIC Seal (Assembled on fitting)
No Code	No Seal (O-Ring not assembled on fitting)

5 Hexagon/ Across flats style

Code	Description
M	Metric Hexagon Dimension
No Code	inch Hexagon Dimension

6 Fitting type

Code	Description
U	Parker Ferulok®

7 Tube connection seal ORFS

Code	Description
O	O-Ring Seal (Assembled on Fitting)
No Code	No Seal/O-Ring

8 Fitting material

Code	Description
S	Steel
SS	Stainless Steel
B	Brass

BU Nut

Flareless
SAE 080110

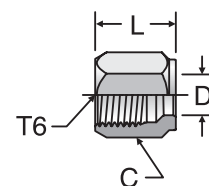

Tube O.D. inch	Thread UN/UNF-2B T6	Hex C inch	Drill D inch	L inch	Weight steel g/1 piece	Ferulok® steel	Ferulok® stainless steel
1/8	5/16-24	3/8	0.13	0.53	5	2 BU-S	2 BU-SS
3/16	3/8-24	7/16	0.19	0.61	5	3 BU-S	3 BU-SS
1/4	7/16-20	9/16	0.26	0.70	14	4 BU-S	4 BU-SS
3/8	9/16-18	11/16	0.38	0.75	18	6 BU-S	6 BU-SS
1/2	3/4-16	7/8	0.51	0.84	32	8 BU-S	8 BU-SS
5/8	7/8-14	1	0.63	0.92	41	10 BU-S	10 BU-SS
3/4	1 1/16-12	1 1/4	0.76	0.97	73	12 BU-S	12 BU-SS
1	1 5/16-12	1 1/2	1.01	1.05	104	16 BU-S	16 BU-SS
1 1/4	1 5/8-12	2	1.26	1.05	222	20 BU-S	20 BU-SS
1 1/2	1 7/8-12	2 1/4	1.51	1.03	254	24 BU-S	24 BU-SS

TU Ferrule

Flareless
SAE 08115A

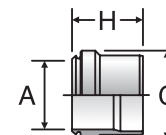

Tube O.D. inch	C inch	A inch	H inch	Ferulok® steel	Ferulok® stainless steel
1/8	0.24	0.13	0.29	2 TU-S	2 TU-SS
3/16	0.31	0.19	0.33	3 TU-S	3 TU-SS
1/4	0.37	0.26	0.36	4 TU-S	4 TU-SS
3/8	0.5	0.38	0.39	6 TU-S	6 TU-SS
1/2	0.66	0.51	0.43	8 TU-S	8 TU-SS
5/8	0.78	0.63	0.44	10 TU-S	10 TU-SS
3/4	0.93	0.76	0.48	12 TU-S	12 TU-SS
1	1.19	1.01	0.48	16 TU-S	16 TU-SS
1 1/4	1.45	1.26	0.48	20 TU-S	20 TU-SS
1 1/2	1.69	1.51	0.48	24 TU-S	24 TU-SS

HBU Union

Flareless / Flareless
SAE 080101

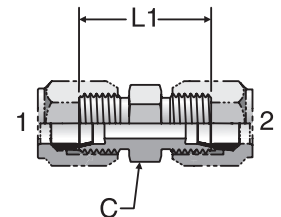

Tube O.D. End 1 inch	Tube O.D. End 2 inch	Hex C inch	L1 inch	Weight steel g/1 piece	Ferulok® steel	Ferulok® stainless steel	Pressure steel bar	Pressure stainless steel bar
1/8	1/8	7/16	1.02	18	2 HBU-S	2 HBU-SS	413	413
3/16	3/16	7/16	1.11	23	3 HBU-S	3 HBU-SS	413	413
1/4	1/4	1/2	1.19	41	4 HBU-S	4 HBU-SS	413	413
3/8	3/8	5/8	1.24	64	6 HBU-S	6 HBU-SS	413	413
1/2	1/2	13/16	1.42	109	8 HBU-S	8 HBU-SS	345	345
5/8	5/8	15/16	1.61	150	10 HBU-S	10 HBU-SS	345	345
3/4	3/4	1 1/8	1.81	281	12 HBU-S	12 HBU-SS	310	310
1	1	1 3/8	1.81	400	16 HBU-S	16 HBU-SS	276	276
1 1/4	1 1/4	1 11/16	1.89	658	20 HBU-S	20 HBU-SS	207	207
1 1/2	1 1/2	2	1.96	785	24 HBU-S	24 HBU-SS	138	138

EBU Union Elbow

Flareless / Flareless
SAE 080201

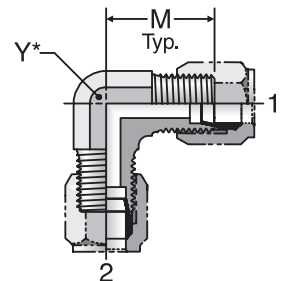

Tube O.D. End 1 inch	Tube O.D. End 2 inch	M inch	Y inch	Weight steel g/1 piece	Ferulok® steel	Ferulok® stainless steel	Pressure steel bar	Pressure stainless steel bar
1/4	1/4	0.89	7/16	50	4 EBU-S	4 EBU-SS	345	345
3/8	3/8	1.05	9/16	86	6 EBU-S	6 EBU-SS	345	345
1/2	1/2	1.25	3/4	150	8 EBU-S	8 EBU-SS	345	345
5/8	5/8	1.42	7/8	218	10 EBU-S	10 EBU-SS	310	310
3/4	3/4	1.58	1 1/16	350	12 EBU-S	12 EBU-SS	276	276
1	1	1.73	1 5/16	518	16 EBU-S	16 EBU-SS	207	207
1 1/4	1 1/4	1.89	1 5/8	981	20 EBU-S	20 EBU-SS	172	172
1 1/2	1 1/2	2.02	1 7/8	1189	24 EBU-S	24 EBU-SS	138	138

JBU Union Tee

Flareless (all three ends)
SAE 080401

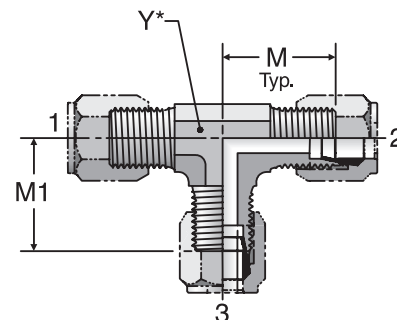

Tube O.D. End 1 inch	Tube O.D. End 2 inch	Tube O.D. End 3 inch	M inch	M1 inch	Y inch	Weight steel g/1 piece	Ferulok® steel	Ferulok® stainless steel	Pressure steel bar	Pressure stainless steel bar
1/4	1/4	1/4	0.89	0.89	7/16	77	4 JBU-S	4 JBU-SS	345	345
3/8	3/8	3/8	1.05	1.05	9/16	123	6 JBU-S	6 JBU-SS	345	345
1/2	1/2	1/2	1.25	1.25	3/4	104	8 JBU-S	8 JBU-SS	345	345
5/8	5/8	5/8	1.42	1.42	7/8	300	10 JBU-S	10 JBU-SS	310	310
3/4	3/4	3/4	1.58	1.58	1 1/16	518	12 JBU-S	12 JBU-SS	276	276
1	1	1	1.73	1.73	1 5/16	713	16 JBU-S	16 JBU-SS	207	207
1 1/4	1 1/4	1 1/4	1.89	1.89	1 5/8	1312	20 JBU-S	20 JBU-SS	172	172
1 1/2	1 1/2	1 1/2	2.02	2.02	1 7/8	1580	24 JBU-S	24 JBU-SS	138	138

WBU Bulkhead Union

Flareless / Flareless
SAE 080601

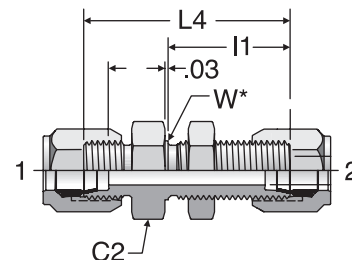

Tube O.D. End 1 inch	Tube O.D. End 2 inch	Hex C2 inch	l1 inch	L4 inch	W inch	Weight steel g/1 piece	Ferulok® steel	Ferulok® stainless steel	Pressure steel bar	Pressure stainless steel bar
1/4	1/4	11/16	1.12	1.89	0.44	68.10	4 WBU-S	4 WBU-SS	413	413
3/8	3/8	13/16	1.17	1.98	0.56	108.96	6 WBU-S	6 WBU-SS	413	413
1/2	1/2	1	1.31	2.22	0.75	167.98	8 WBU-S	8 WBU-SS	345	345
5/8	5/8	1 1/8	1.45	2.48	0.88	222.46	10 WBU-S	10 WBU-SS	345	345
3/4	3/4	1 3/8	1.55	2.72	1.06	372.28	12 WBU-S	12 WBU-SS	310	310
1	1	1 5/8	1.56	2.72	1.31	499.40	16 WBU-S	16 WBU-SS	276	276

C6BU Swivel Nut Elbow

Flareless / Flareless Swivel
SAE 080221

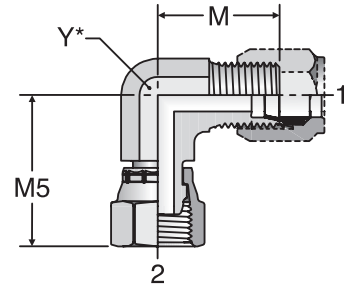

Tube O.D. End 1 inch	Tube O.D. End 2 inch	M inch	M5 inch	Y inch	Weight steel g/1 piece	Ferulok® steel	Ferulok® stainless steel	Pressure steel bar	Pressure stainless steel bar
1/4	1/4	0.89	1.00	7/16	36	4 C6BU-S	4 C6BU-SS	345	345
3/8	3/8	1.05	1.25	9/16	64	6 C6BU-S	6 C6BU-SS	345	345
1/2	1/2	1.25	1.38	3/4	114	8 C6BU-S	8 C6BU-SS	345	345
5/8	5/8	1.42	1.62	7/8	159	10 C6BU-S	10 C6BU-SS	310	310
3/4	3/4	1.58	1.75	1 1/16	254	12 C6BU-S	12 C6BU-SS	276	276
1	1	1.73	2.00	1 5/16	381	16 C6BU-S	16 C6BU-SS	207	207
1 1/4	1 1/4	1.89	2.31	1 5/8	518	20 C6BU-S	20 C6BU-SS	172	172
1 1/2	1 1/2	2.02	2.42	1 7/8	531	24 C6BU-S	24 C6BU-SS	138	138

S6BU Swivel Nut Branch Tee

Flareless / Flareless Swivel
SAE 080202

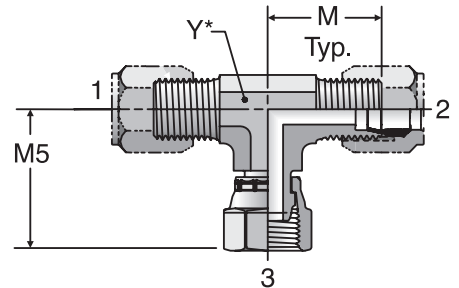

Tube O.D. End 1 inch	Tube O.D. End 2 inch	Tube O.D. End 3 inch	M inch	M5 inch	Y inch	Weight steel g/1 piece	Ferulok® steel	Ferulok® stainless steel	Pressure steel bar	Pressure stainless steel bar
1/4	1/4	1/4	0.89	1.00	7/16	59	4 S6BU-S	4 S6BU-SS	345	345
3/8	3/8	3/8	1.05	1.25	9/16	95	6 S6BU-S	6 S6BU-SS	345	345
1/2	1/2	1/2	1.25	1.38	3/4	173	8 S6BU-S	8 S6BU-SS	345	345
3/4	3/4	3/4	1.58	1.75	1 1/16	390	12 S6BU-S	12 S6BU-SS	276	276
1	1	1	1.73	2.00	1 5/16	454	16 S6BU-S	16 S6BU-SS	207	207

R6BU Swivel Nut Run Tee

Flareless / Flareless Swivel
SAE 080432

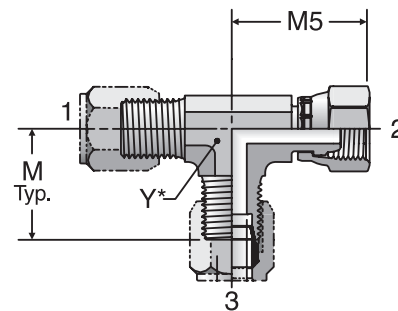

Tube O.D. End 1 inch	Tube O.D. End 2 inch	Tube O.D. End 3 inch	M inch	M5 inch	Y inch	Weight steel g/1 piece	Ferulok® steel	Ferulok® stainless steel	Pressure steel bar	Pressure stainless steel bar
1/4	1/4	1/4	0.89	1.00	7/16	59	4 R6BU-S	4 R6BU-SS	345	345
3/8	3/8	3/8	1.05	1.25	9/16	100	6 R6BU-S	6 R6BU-SS	345	345
1/2	1/2	1/2	1.25	1.38	3/4	177	8 R6BU-S	8 R6BU-SS	345	345
3/4	3/4	3/4	1.58	1.75	1 1/16	495	12 R6BU-S	12 R6BU-SS	276	276
1	1	1	1.73	2.00	1 5/16	826	16 R6BU-S	16 R6BU-SS	207	207

TRBU Tube End Reducer

Tube / Flareless
SAE 080123

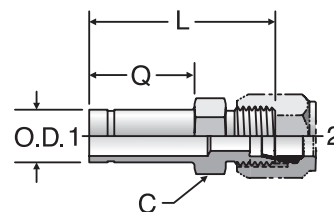

Tube O.D. End 1 inch	Tube O.D. End 2 inch	Hex C inch	L inch	Q inch	Weight steel g/1 piece	Ferulok® steel	Ferulok® stainless steel	Pressure steel bar	Pressure stainless steel bar
3/8	1/4	1/2	1.61	0.88	27	6-4 TRBU-S	6-4 TRBU-SS	413	413
1/2	1/4	9/16	1.73	1	36	8-4 TRBU-S	8-4 TRBU-SS	345	345
1/2	3/8	5/8	1.77	1	45	8-6 TRBU-S	8-6 TRBU-SS	345	345
5/8	3/8	11/16	1.86	1.09	54	10-6 TRBU-S	10-6 TRBU-SS	345	345
5/8	1/2	13/16	1.95	1.09	73	10-8 TRBU-S	10-8 TRBU-SS	310	310
3/4	3/8	13/16	1.94	1.16	68	12-6 TRBU-S	12-6 TRBU-SS	310	310
3/4	1/2	13/16	2.03	1.16	77	12-8 TRBU-S	12-8 TRBU-SS	310	310
3/4	5/8	15/16	2.16	1.16	100	12-10 TRBU-S	12-10 TRBU-SS	310	310
1	1/2	1 1/16	2.05	1.13	114	16-8 TRBU-S	16-8 TRBU-SS	276	276
1	5/8	1 1/16	2.11	1.13	132	16-10 TRBU-S	16-10 TRBU-SS	276	276
1	3/4	1 1/8	2.25	1.13	168	16-12 TRBU-S	16-12 TRBU-SS	276	276
1 1/4	1	1 3/8	2.28	1.16	250	20-16 TRBU-S	20-16 TRBU-SS	207	207
1 1/2	3/4	1 5/8	2.45	1.25	268	24-12 TRBU-S	24-12 TRBU-SS	138	138
1 1/2	1	1 5/8	2.45	1.25	336	24-16 TRBU-S	24-16 TRBU-SS	138	138
1 1/2	1 1/4	1 7/8	2.45	1.25	440	24-20 TRBU-S	24-20 TRBU-SS	138	138

F5BU Straight Thread Connector

Flareless / SAE-ORB
SAE 080120

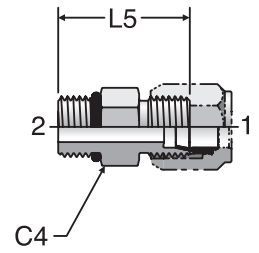

End 1 inch	End 2 UN/UNF-2A inch	Hex C4 inch	L5 inch	Weight steel g/1 piece	Ferulok® steel	Ferulok® stainless steel	Pressure steel bar	Pressure stainless steel bar
1/4	7/16-20	9/16	1.13	27	4 F5BU-S	4 F5BU-SS	413	413
3/8	9/16-18	11/16	1.22	50	6 F5BU-S	6 F5BU-SS	413	413
1/2	3/4-16	7/8	1.38	82	8 F5BU-S	8 F5BU-SS	345	345
5/8	7/8-14	1	1.56	109	10 F5BU-S	10 F5BU-SS	345	345
3/4	1 1/16-12	1 1/4	1.78	195	12 F5BU-S	12 F5BU-SS	310	310
1	1 5/16-12	1 1/2	1.81	250	16 F5BU-S	16 F5BU-SS	276	276

FBU Male Connector

Flareless / NPTF
SAE 080102

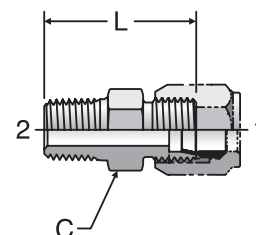

End 1 inch	End 2 NPTF inch	Hex C inch	L inch	Weight steel g/1 piece	Ferulok® steel	Ferulok® stainless steel	Pressure steel bar	Pressure stainless steel bar
1/8	1/8-27	7/16	1.04	18	2 FBU-S	2 FBU-SS	413	413
1/8	1/4-18	9/16	1.24	32	2-4 FBU-S	2-4 FBU-SS	413	413
1/4	1/8-27	1/2	1.12	27	4 FBU-S	4 FBU-SS	413	413
1/4	1/4-18	9/16	1.32	36	4-4 FBU-S	4-4 FBU-SS	413	413
1/4	3/8-18	3/4	1.33	36	4-6 FBU-S	4-6 FBU-SS	413	413
1/4	1/2-14	7/8	1.58	64	4-8 FBU-S	4-8 FBU-SS	413	413
3/8	1/4-18	5/8	1.34	45	6 FBU-S	6 FBU-SS	413	413
3/8	1/8-27	5/8	1.15	45	6-2 FBU-S	6-2 FBU-SS	413	413
3/8	3/8-18	3/4	1.35	59	6-6 FBU-S	6-6 FBU-SS	413	413
3/8	1/2-14	15/16	1.6	91	6-8 FBU-S	6-8 FBU-SS	413	413
1/2	3/8-18	13/16	1.44	77	8 FBU-S	8 FBU-SS	345	345
1/2	1/4-18	13/16	1.44	73	8-4 FBU-S	8-4 FBU-SS	345	345
1/2	1/2-14	7/8	1.69	100	8-8 FBU-S	8-8 FBU-SS	345	345
1/2	3/4-14	1 1/8	1.76	118	8-12 FBU-S	8-12 FBU-SS	276	276
3/4	3/4-14	1 1/8	1.88	182	12 FBU-S	12 FBU-SS	276	276
3/4	1/2-14	1 1/8	1.88	168	12-8 FBU-S	12-8 FBU-SS	276	276
1	1-11 1/2	1 3/8	2.07	272	16 FBU-S	16 FBU-SS	207	207
1	3/4-14	1 3/8	1.88	236	16-12 FBU-S	16-12 FBU-SS	207	207
1 1/4	1 1/4-11 1/2	1 11/16	2.18	499	20 FBU-S	20 FBU-SS	172	172
1 1/2	1 1/2-11 1/2	2	2.28	499	24 FBU-S	24 FBU-SS	172	172



C5BU Straight Thread Elbow

Flareless / SAE-ORB
SAE 080220

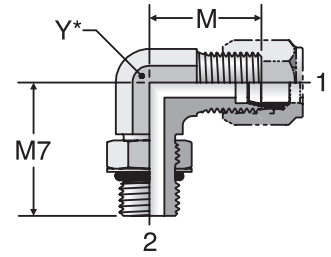

End 1 inch	End 2 UN/UNF-2A inch	M inch	M7 inch	Y inch	Weight steel g/1 piece	Ferulok® steel	Ferulok® stainless steel	Pressure steel bar	Pressure stainless steel bar
1/4	7/16-20	0.89	1.03	7/16	36	4 C5BU-S	4 C5BU-SS	345	345
3/8	9/16-18	1.05	1.25	9/16	59	6 C5BU-S	6 C5BU-SS	345	345
1/2	3/4-16	1.25	1.45	3/4	132	8 C5BU-S	8 C5BU-SS	345	345
5/8	7/8-14	1.42	1.70	7/8	191	10 C5BU-S	10 C5BU-SS	310	310
3/4	1 1/16-12	1.58	1.94	1 1/16	263	12 C5BU-S	12 C5BU-SS	276	276
1	1 5/16-12	1.73	2.05	1 5/16	463	16 C5BU-S	16 C5BU-SS	207	207
1 1/4	1 5/8-12	1.89	2.25	1 5/8	772	20 C5BU-S	20 C5BU-SS	172	172
1 1/2	1 7/8-12	2.02	2.39	1 7/8	944	24 C5BU-S	24 C5BU-SS	138	138

CBU Male Elbow

Flareless / NPTF
SAE 080202

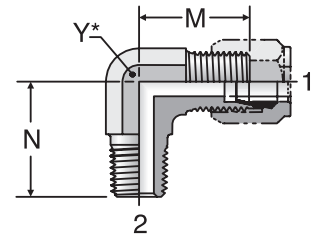

End 1 inch	End 2 NPTF inch	M inch	N inch	Y inch	Weight steel g/1 piece	Ferulok® steel	Ferulok® stainless steel	Pressure steel bar	Pressure stainless steel bar
1/4	1/8-27	0.89	0.78	7/16	36	4 CBU-S	4 CBU-SS	345	345
3/8	1/4-18	1.05	1.09	9/16	64	6 CBU-S	6 CBU-SS	345	345
3/8	3/8-18	1.14	1.22	3/4	95	6-6 CBU-S	6 CBU-SS	345	345
1/2	3/8-18	1.25	1.22	3/4	114	8 CBU-S	8 CBU-SS	345	345
1/2	1/2-14	1.35	1.47	7/8	149	8-8 CBU-S	8-8 CBU-SS	345	345
5/8	1/2-14	1.42	1.47	7/8	168	10 CBU-S	10 CBU-SS	310	310
3/4	3/4-14	1.58	1.59	1 1/16	272	12 CBU-S	12 CBU-SS	276	276
1	1-11 1/2	1.73	1.97	1 5/16	413	16 CBU-S	16 CBU-SS	207	207
1 1/4	1 1/4-11 1/2	1.89	2.38	1 5/8	754	20 CBU-S	20 CBU-SS	172	172
1 1/2	1 1/2-11 1/2	2.02	2.64	1 7/8	926	24 CBU-S	24 CBU-SS	172	172

GBU Female Connector

Flareless / NPTF
SAE 080103

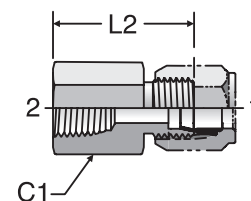

End 1 inch	End 2 inch	Hex C1 inch	L2 inch	Weight steel g/1 piece	Ferulok® steel	Ferulok® stainless steel	Pressure steel bar	Pressure stainless steel bar
1/4	1/8-27	9/16	1.09	32	4 GBU-S	4 GBU-SS	345	345
3/8	1/4-18	3/4	1.31	59	6 GBU-S	6 GBU-SS	345	345
1/2	3/8-18	7/8	1.47	91	8 GBU-S	8 GBU-SS	345	345
5/8	1/2-14	1 1/8	1.77	159	10 GBU-S	10 GBU-SS	310	310
3/4	3/4-14	1 3/8	1.89	250	12 GBU-S	12 GBU-SS	276	276
1	1-11 1/2	1 5/8	2.13	359	16 GBU-S	16 GBU-SS	207	207
1 1/4	1 1/4-11 1/2	2	2.22	636	20 GBU-S	20 GBU-SS	172	172
1 1/2	1 1/2-11 1/2	2 3/8	2.23	667	24 GBU-S	24 GBU-SS	172	172

FNU Cap

Flareless Swivel
SAE 080112

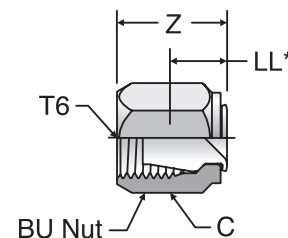

Tube O.D. inch	T6UN/UNF-2B inch	Hex C inch	LL inch	Z inch	Weight steel g/1 piece	Ferulok® steel	Ferulok® stainless steel
1/4	7/16-24	9/16	0.36	0.73	4.54	4 FNU-S	4 FNU-SS
3/8	9/16-18	11/16	0.42	0.80	13.62	6 FNU-S	6 FNU-SS
1/2	3/4-16	7/8	0.44	0.87	27.24	8 FNU-S	8 FNU-SS
5/8	7/8-14	1	0.47	0.98	40.86	10 FNU-S	10 FNU-SS
3/4	1 1/16-12	1 1/4	0.48	1.00	59.02	12 FNU-S	12 FNU-SS
1	1 5/16-12	1 1/2	0.58	1.08	72.64	16 FNU-S	16 FNU-SS
1 1/4	1 5/8-12	2	0.64	1.11	104.42	20 FNU-S	20 FNU-SS

PNU Plug

Flareless
SAE 080109

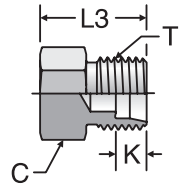

Tube O.D. inch	T Tube End UN/UNF 2A inch	Hex C inch	K inch	L3 inch	Weight steel g/1 piece	Ferulok® steel	Ferulok® stainless steel	Pressure steel bar	Pressure stainless steel bar
1/4	7/16-20	1/2	0.24	0.72	9	4 PNU-S	4 PNU-SS	413	413
3/8	9/16-18	5/8	0.26	0.75	18	6 PNU-S	6 PNU-SS	413	413
1/2	3/4-16	13/16	0.31	0.84	36	8 PNU-S	8 PNU-SS	345	345
5/8	7/8-14	15/16	0.36	0.97	54	10 PNU-S	10 PNU-SS	345	345
3/4	1 1/16-12	1 1/8	0.36	1.09	91	12 PNU-S	12 PNU-SS	310	310
1	1 5/16-12	1 3/8	0.42	1.09	168	16 PNU-S	16 PNU-SS	276	276



EO[®] Ermeto Original
Weld fittings

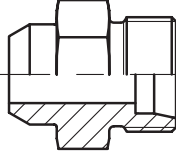
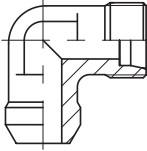
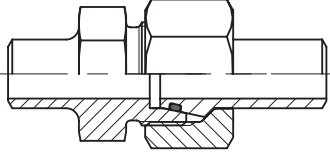
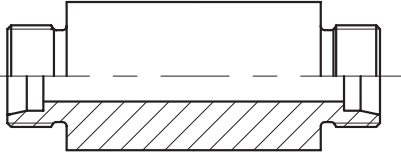
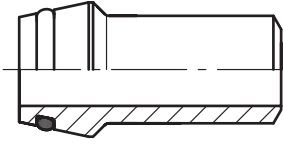
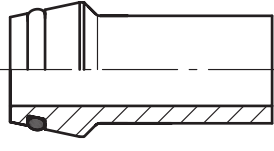
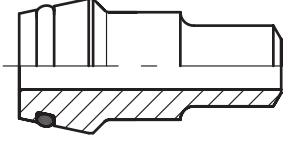
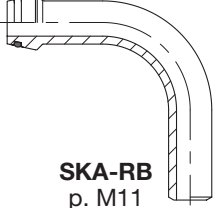
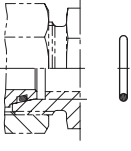

Visual index

<p>Tube to weld</p>	 <p>AS p. M3</p>	 <p>WAS p. M4</p>
<p>Weld fitting</p>	 <p>ASK p. M5</p>	
<p>Weld bulkhead</p>	 <p>ESV p. M6</p>	
<p>Weld nipple</p>	 <p>SKA p. M7</p>	 <p>SKA-ORB p. M10</p>
<p>Reducing weld nipple</p>	 <p>SKAR p. M8/9</p>	
<p>Tube bend weld nipple</p>	 <p>SKA-RB p. M11</p>	
<p>O-ring</p>	 <p>O-ring p. M12</p>	

AS Weld connector

Butt weld / EO 24° cone end

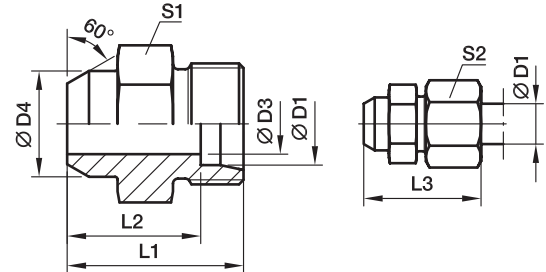

Series	D1	D3	D4	L1	L2	L3	S1	S2	Weight g/1 piece	Order code	PN (bar) ¹⁾	
											Steel	Stainless Steel
L ³⁾	06	4	10	21	14.0	29	12	14	11	AS06L	315	315
	08	6	12	23	16.0	31	14	17	15	AS08L	315	315
	10	8	14	25	18.0	33	17	19	22	AS10L	315	315
	12	10	16	25	18.0	33	19	22	25	AS12L	315	315
	15	12	19	29	22.0	37	22	27	44	AS15L	315	315
	18	15	22	31	23.5	40	27	32	67	AS18L	315	315
	22	19	27	36	28.5	45	32	36	98	AS22L	160	160
	28	24	32	38	30.5	47	41	41	165	AS28L	160	160
	35	30	40	43	32.5	54	46	50	232	AS35L	160	160
	42	36	46	46	35.0	58	55	60	342	AS42L	160	160
S ⁴⁾	06	4	11	26	19.0	34	14	17	21	AS06S	630	630
	08	5	13	28	21.0	36	17	19	31	AS08S	630	630
	10	7	15	30	22.5	39	19	22	41	AS10S	630	630
	12	8	17	32	24.5	41	22	24	93	AS12S	630	630
	16	12	21	35	26.5	45	27	30	82	AS16S	400	400
	20	16	26	40	29.5	51	32	36	131	AS20S	400	400
	25	20	31	44	32.0	56	41	46	219	AS25S	400	400
	30	25	36	49	35.5	62	46	50	297	AS30S	400	400
	38	32	44	54	38.0	69	55	60	448	AS38S	315	315

¹⁾ Pressure shown = item deliverable

³⁾ L = light series; ⁴⁾ S = heavy series

$\frac{\text{PN (bar)}}{10} = \text{PN (MPa)}$

Delivery without nut and ring. Information on ordering complete fittings or alternative sealing materials see page 17.

*Please add the **suffixes** below according to the material/surface required.

Order code suffixes		
Material	Suffix surface and material	Example
Steel		AS16SX
Stainless Steel	71X	AS16S71X

WAS Weld elbow

Butt weld / EO 24° cone end

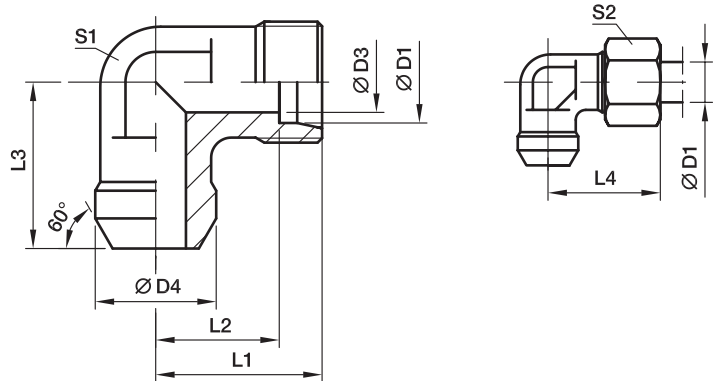

Series	D1	D3	D4	L1	L2	L3	L4	S1	S2	Weight g/1 piece	Order code	PN (bar) ¹⁾	
												Steel	Stainless Steel
L ³⁾	06	4	10	19	12.0	19	27	12	14	20	WAS06L	315	315
	08	6	12	21	14.0	23	29	12	17	25	WAS08L	315	315
	10	8	14	22	15.0	24	30	14	19	34	WAS10L	315	315
	12	10	16	24	17.0	25	32	17	22	45	WAS12L	315	315
	15	12	19	28	21.0	30	36	19	27	81	WAS15L	315	315
	18	15	22	31	23.5	33	40	24	32	113	WAS18L	315	315
	22	19	27	35	27.5	37	44	27	36	151	WAS22L	160	160
	28	24	32	38	30.5	42	47	36	41	271	WAS28L	160	160
	35	30	40	45	34.5	49	56	41	50	113	WAS35L	160	160
	42	36	46	51	40.0	57	63	50	60	420	WAS42L	160	160
S ⁴⁾	06	4	11	23	16.0	23	31	12	17	31	WAS06S	630	630
	08	5	13	24	17.0	24	32	14	19	44	WAS08S	630	630
	10	7	15	25	17.5	25	34	17	22	59	WAS10S	630	630
	12	8	17	29	21.5	29	38	17	24	78	WAS12S	630	630
	16	12	21	33	24.5	33	43	24	30	133	WAS16S	400	400
	20	16	26	37	26.5	37	48	27	36	192	WAS20S	400	400
	25	20	31	42	30.0	42	54	36	46	351	WAS25S	400	400
	30	25	36	49	35.5	49	62	41	50	525	WAS30S	400	400
	38	32	44	57	41.0	57	72	50	60	785	WAS38S	315	315

¹⁾ Pressure shown = item deliverable

³⁾ L = light series; ⁴⁾ S = heavy series

PN (bar) = PN (MPa)
10

Delivery without nut and ring. Information on ordering complete fittings or alternative sealing materials see page 17.

*Please add the **suffixes** below according to the material/ surface required.

Order code suffixes		
Material	Suffix surface and material	Example
Steel		WAS16SX
Stainless Steel	71X	WAS16S71X

ASK Weld fitting for tubes

Butt weld / Butt weld

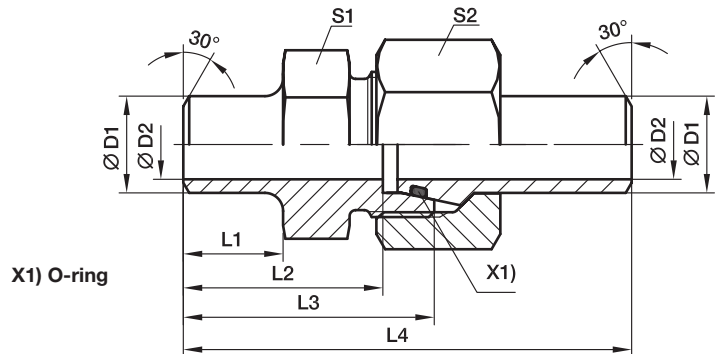

Series	D1	D2	L1	L2	L3	L4	S1	S2	recommended tube	Weight g/1 piece	Order code	PN (bar) ¹⁾	
												Steel	Stainless Steel
S ⁴⁾	10	8	10.0	24.5	32.0	58.0	19	22	10x1.0	75	ASK610X1S	249	242
	10	7	10.0	24.5	32.0	58.0	19	22	10x1.5	81	ASK610X1.5S	358	349
	10	6	10.0	24.5	32.0	58.0	19	22	10x2.0	86	ASK610X2S	460	447
	12	9	15.0	29.5	37.0	63.0	22	24	12x1.5	106	ASK612X1.5S	305	297
	12	8	15.0	29.5	37.0	63.0	22	24	12x2.0	107	ASK612X2S	393	383
	12	7	15.0	29.5	37.0	63.0	22	24	12x2.5	109	ASK612X2.5S	476	463
	16	13	16.5	33.0	41.5	73.5	27	30	16x1.5	166	ASK616X1.5S	234	228
	16	12	16.5	33.0	41.5	73.5	27	30	16x2.0	175	ASK616X2S	305	297
	16	11	16.5	33.0	41.5	73.5	27	30	16x2.5	184	ASK616X2.5S	372	362
	16	10	16.5	33.0	41.5	73.5	27	30	16x3.0	193	ASK616X3S	400	400
	20	16	19.0	36.5	47.0	83.5	32	36	20x2.0	301	ASK620X2S	249	242
	20	15	19.0	36.5	47.0	83.5	32	36	20x2.5	311	ASK620X2.5S	305	297
	20	14	19.0	36.5	47.0	83.5	32	36	20x3.0	316	ASK620X3S	358	349
	20	12	19.0	36.5	47.0	83.5	32	36	20x4.0	322	ASK620X4S	400	400
	25	19	19.5	39.5	51.5	92.5	41	46	25x3.0	551	ASK625X3S	294	286
	25	17	19.5	39.5	51.5	92.5	41	46	25x4.0	559	ASK625X4S	379	369
25	15	19.5	39.5	51.5	92.5	41	46	25x5.0	589	ASK625X5S	400	400	
30	24	23.0	44.5	58.0	101.5	46	50	30x3.0	671	ASK630X3S	249	242	
30	22	23.0	44.5	58.0	101.5	46	50	30x4.0	679	ASK630X4S	323	314	
30	20	23.0	44.5	58.0	101.5	46	50	30x5.0	726	ASK630X5S	393	383	
30	18	23.0	44.5	58.0	101.5	46	50	30x6.0	791	ASK630X6S	400	400	
38	30	22.0	44.0	60.0	108.0	55	60	38x4.0	988	ASK638X4S	261	254	
38	28	22.0	44.0	60.0	108.0	55	60	38x5.0	1044	ASK638X5S	315	311	
38	26	22.0	44.0	60.0	108.0	55	60	38x6.0	1108	ASK638X6S	315	315	
38	24	22.0	44.0	60.0	108.0	55	60	38x7.0	1205	ASK638X7S	315	315	

1) Pressure shown = item deliverable

4) S = heavy series

$$\frac{\text{PN (bar)}}{10} = \text{PN (MPa)}$$

*Please add the **suffixes** below according to the material/surface required.

Order code suffixes			
Material	Suffix surface and material	Example	Standard sealing material (no additional suffix needed)
Steel		ASK616X2S	NBR
Stainless Steel	71	ASK616X2S71	VIT

ESV Weld bulkhead fitting

EO 24° cone end / EO 24° cone end

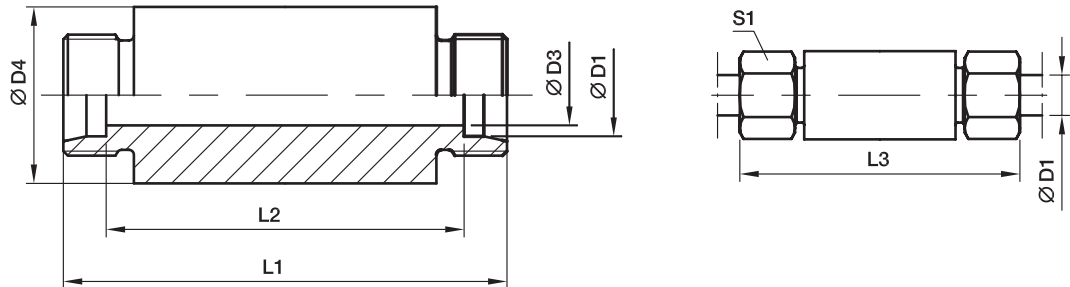

Series	D1	D3	D4	L1	L2	L3	S1	Weight g/1 piece	Order code	PN (bar) ¹⁾	
										Steel	Stainless Steel
L ³⁾	06	4	18	70	56	85	14	103	ESV06L	500	315
	08	6	20	70	56	85	17	121	ESV08L	500	315
	10	8	22	72	58	87	19	142	ESV10L	500	315
	12	10	25	72	58	87	22	176	ESV12L	400	315
	15	12	28	84	70	100	27	262	ESV15L	400	315
	18	15	32	84	69	101	32	333	ESV18L	400	315
	22	19	36	88	73	105	36	394	ESV22L	250	160
	28	24	40	88	73	106	41	448	ESV28L	250	160
	35	30	50	92	71	114	50	713	ESV35L	250	160
	42	36	60	92	70	115	60	997	ESV42L	250	160
S ⁴⁾	06	4	20	74	60	89	17	135	ESV06S	800	630
	08	5	22	74	60	89	19	163	ESV08S	800	630
	10	7	25	74	59	91	22	201	ESV10S	800	630
	12	8	28	74	59	91	24	249	ESV12S	630	630
	16	12	35	88	71	107	30	441	ESV16S	630	400
	20	16	38	92	71	114	36	509	ESV20S	420	400
	25	20	45	96	72	120	46	720	ESV25S	420	400
	30	25	50	100	73	126	50	873	ESV30S	420	400
	38	32	60	104	72	133	60	1248	ESV38S	420	315

¹⁾ Pressure shown = item deliverable

³⁾ L = light series; ⁴⁾ S = heavy series

$$\frac{\text{PN (bar)}}{10} = \text{PN (MPa)}$$

Delivery without nut and ring. Information on ordering complete fittings or alternative sealing materials see page 17.

*Please add the **suffixes** below according to the material/surface required.

Order code suffixes		
Material	Suffix surface and material	Example
Steel		ESV16SX
Stainless Steel	71X	ESV16S71X

SKA Weld nipple

EO 24° O-ring weld nipple / butt weld

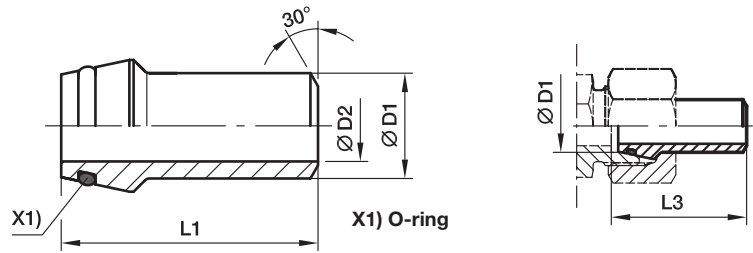

Series	D1	D2	L1	L3	recommended tube	Weight g/1 piece	Order code	PN (bar) ¹⁾		
								Steel	Stainless Steel	
L ³⁾ /S ⁴⁾	06	3.0	31.0	31.5	06x1.5	7	SKA06X1.5	528	539	
	08	4.5	31.0	31.5	08x1.5	11	SKA08X1.5	414	424	
	08	4.0	31.0	31.5	08x2.0	11	SKA08X2	528	539	
	10	8.0	32.5	33.5	10x1.0	13	SKA10X1	249	242	
	10	7.0	32.5	33.5	10x1.5	13	SKA10X1.5	358	349	
	10	6.0	32.5	33.5	10x2.0	16	SKA10X2	460	447	
	12	8.0	32.5	33.5	12x1.5	21	SKA12X1.5	305	297	
	12	8.0	32.5	33.5	12x2.0	20	SKA12X2	393	383	
	12	7.0	32.5	33.5	12x2.5	22	SKA12X2.5	476	463	
	L ³⁾	15	11.0	34.0	34.5	15x2.0	29	SKA15X2	315	315
		15	10.0	34.0	34.5	15x2.5	31	SKA15X2.5	315	315
		18	13.0	35.5	36.5	18x2.5	40	SKA18X2.5	315	315
22		17.0	38.5	39.5	22x2.5	57	SKA22X2.5	160	160	
28		23.0	41.5	42.5	28x2.5	73	SKA28X2.5	160	160	
28		22.0	41.5	42.5	28x3.0	89	SKA28X3	160	160	
35		28.0	47.5	49.5	35x3.5	140	SKA35X3.5	160	160	
35		27.0	47.5	49.5	35x4.0	150	SKA35X4	160	160	
42		36.0	47.5	50.0	42x3.0	155	SKA42X3	160	160	
42		34.0	47.5	50.0	42x4.0	190	SKA42X4	160	160	
S ⁴⁾		16	13.0	39.0	40.5	16x1.5	32	SKA16X1.5	234	228
		16	12.0	39.0	40.5	16x2.0	31	SKA16X2	305	297
	16	11.0	39.0	40.5	16x2.5	38	SKA16X2.5	372	362	
	16	10.0	39.0	40.5	16x3.0	41	SKA16X3	400	400	
	20	16.0	45.0	47.0	20x2.0	57	SKA20X2	249	242	
	20	15.0	45.0	47.0	20x2.5	57	SKA20X2.5	305	297	
	20	14.0	45.0	47.0	20x3.0	64	SKA20X3	358	349	
	20	13.0	45.0	47.0	20x3.5	71	SKA20X3.5	400	400	
	20	12.0	45.0	47.0	20x4.0	78	SKA20X4	400	400	
	25	19.0	49.5	53.0	25x3.0	89	SKA25X3	294	286	
	25	18.0	49.5	53.0	25x3.5	100	SKA25X3.5	337	328	
	25	17.0	49.5	53.0	25x4.0	111	SKA25X4	379	369	
	25	15.0	49.5	53.0	25x5.0	125	SKA25X5	400	400	
	30	24.0	52.0	57.0	30x3.0	113	SKA30X3	249	242	
	30	22.0	52.0	57.0	30x4.0	141	SKA30X4	323	314	
	30	20.0	52.0	57.0	30x5.0	166	SKA30X5	393	383	
	30	18.0	52.0	57.0	30x6.0	188	SKA30X6	400	400	
	38	32.0	56.5	64.0	38x3.0	163	SKA38X3	200	195	
	38	30.0	56.5	64.0	38x4.0	209	SKA38X4	261	254	
	38	28.0	56.5	64.0	38x5.0	247	SKA38X5	315	315	
	38	26.0	56.5	64.0	38x6.0	270	SKA38X6	315	370	
	38	24.0	56.5	64.0	38x7.0	270	SKA38X7	315	420	

¹⁾ Pressure shown = item deliverable

³⁾ L = light series; ⁴⁾ S = heavy series

$$\frac{\text{PN (bar)}}{10} = \text{PN (MPa)}$$

*Please add the **suffixes** below according to the material/surface required.

Order code suffixes			
Material	Suffix surface and material	Example	Standard sealing material (no additional suffix needed)
Steel		SKA16X2	NBR
Stainless Steel	71	SKA16X271	VIT

SKAR Reducing weld nipple

EO 24° O-ring weld nipple / butt weld

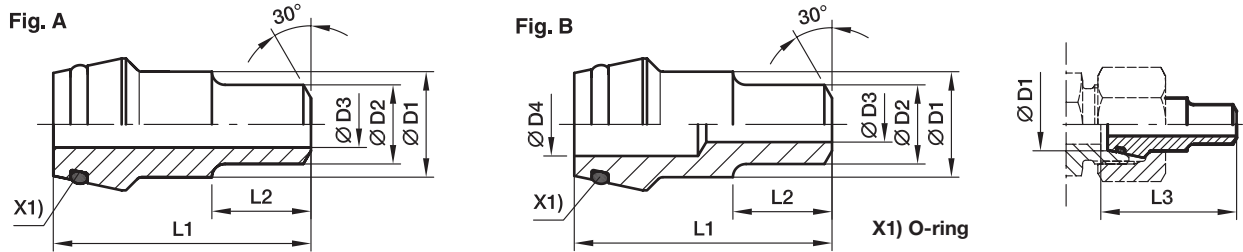

Series	D1	D2	D3	D4	L1	L2	L3	Fig.	Weight g/1 piece	Order code	PN (bar) ¹⁾		
											Steel	Stainless Steel	
L ³⁾ /S ⁴⁾	08	06	3	5	31.0	12	31.5	A	14	SKAR08/06X1.5	528	539	
	10	06	3		32.5	12	33.5	B	15	SKAR10/06X1.5	528	539	
	10	08	5		32.5	12	33.5	A	16	SKAR10/08X1.5	414	424	
	10	08	4	6	32.5	12	33.5	A	17	SKAR10/08X2	528	539	
	12	08	5		32.5	14	33.5	A	18	SKAR12/08X1.5	414	424	
	12	08	4		32.5	14	33.5	B	20	SKAR12/08X2	528	539	
	12	10	7		32.5	14	33.5	A	18	SKAR12/10X1.5	358	349	
S ⁴⁾	16	10	6		39.0	15	40.5	A	43	SKAR16/10X2	400	400	
	16	12	9		39.0	15	40.5	A	45	SKAR16/12X1.5	305	297	
	16	12	8		39.0	15	40.5	A	47	SKAR16/12X2	393	383	
	16	12	7		39.0	15	40.5	A	49	SKAR16/12X2.5	400	400	
	20	12	9		45.0	17	47.0	A	76	SKAR20/12X1.5	305	297	
	20	12	8		45.0	17	47.0	A	78	SKAR20/12X2	393	383	
	20	12	7		45.0	17	47.0	A	80	SKAR20/12X2.5	400	400	
	20	12	6		45.0	17	47.0	A	86	SKAR20/12X3	400	400	
	20	16	12		45.0	17	47.0	A	74	SKAR20/16X2	305	297	
	20	16	11		45.0	17	47.0	A	76	SKAR20/16X2.5	372	362	
	20	16	10		45.0	17	47.0	A	78	SKAR20/16X3	400	400	
	25	12	9		49.5	20	53.0	A	117	SKAR25/12X1.5	305	297	
	25	12	8		49.5	20	53.0	A	121	SKAR25/12X2	393	383	
	25	12	7		49.5	20	53.0	A	125	SKAR25/12X2.5	400	400	
	25	12	6		15	49.5	20	53.0	B	129	SKAR25/12X3	400	400
	25	16	12	49.5		20	53.0	A	115	SKAR25/16X2	305	297	
	25	16	11	49.5		20	53.0	A	120	SKAR25/16X2.5	372	362	
	25	16	10	49.5		20	53.0	A	123	SKAR25/16X3	400	400	
	25	20	16	49.5		20	53.0	A	94	SKAR25/20X2	249	242	
	25	20	15			49.5	20	53.0	A	104	SKAR25/20X2.5	305	297
	25	20	14			49.5	20	53.0	A	114	SKAR25/20X3	358	349
	25	20	12		49.5	20	53.0	A	124	SKAR25/20X4	400	400	
	30	12	9		22	52.0	22	57.0	B	135	SKAR30/12X1.5	305	297
	30	12	8			52.0	22	57.0	B	145	SKAR30/12X2	323	383
	30	12	6		22	52.0	22	57.0	B	155	SKAR30/12X3	400	400
	30	16	12			52.0	22	57.0	A	166	SKAR30/16X2	305	297
	30	16	11			52.0	22	57.0	A	176	SKAR30/16X2.5	323	362
	30	20	16	52.0		22	57.0	A	149	SKAR30/20X2	249	242	
	30	20	15	52.0		22	57.0	A	159	SKAR30/20X2.5	305	297	
	30	20	14			52.0	22	57.0	A	169	SKAR30/20X3	358	349
	30	20	12			52.0	22	57.0	A	184	SKAR30/20X4	400	400
	30	25	20			52.0	22	57.0	A	141	SKAR30/25X2.5	249	242
30	25	19	52.0			22	57.0	A	156	SKAR30/25X3	294	286	
30	25	17	52.0			22	57.0	A	168	SKAR30/25X4	379	369	

SKAR Reducing weld nipple

EO 24° O-ring weld nipple / butt weld

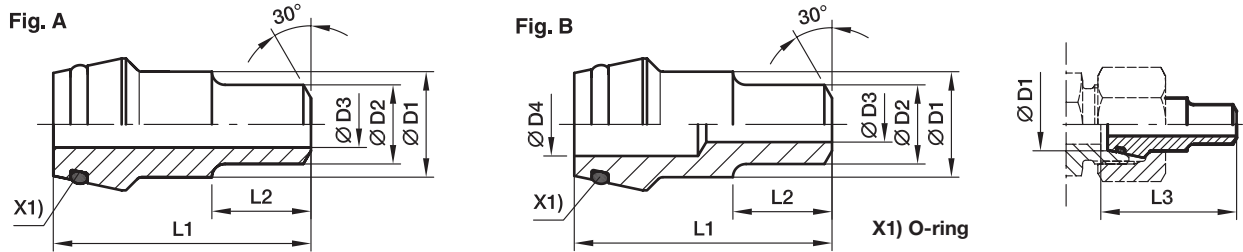

Series	D1	D2	D3	D4	L1	L2	L3	Fig.	Weight g/1 piece	Order code	PN (bar) ¹⁾	
											Steel	Stainless Steel
S ⁴⁾	38	12	9	28	56.5	26	64.0	B	219	SKAR38/12X1.5	305	297
	38	12	8	28	56.5	26	64.0	B	234	SKAR38/12X2	315	315
	38	12	6	28	56.5	26	64.0	B	249	SKAR38/12X3	315	315
	38	16	12		56.5	26	64.0	A	279	SKAR38/16X2	305	297
	38	16	11		56.5	26	64.0	A	294	SKAR38/16X2.5	315	315
	38	16	10		56.5	26	64.0	A	309	SKAR38/16X3	315	315
	38	20	16		56.5	26	64.0	A	263	SKAR38/20X2	249	242
	38	20	15		56.5	26	64.0	A	278	SKAR38/20X2.5	305	297
	38	20	14		56.5	26	64.0	A	293	SKAR38/20X3	315	315
	38	20	12		56.5	26	64.0	A	299	SKAR38/20X4	315	315
	38	25	20		56.5	26	64.0	A	242	SKAR38/25X2.5	249	242
	38	25	19		56.5	26	64.0	A	262	SKAR38/25X3	294	286
	38	25	17		56.5	26	64.0	B	285	SKAR38/25X4	315	315
	38	30	24		56.5	26	64.0	A	256	SKAR38/30X3	249	242
	38	30	22		56.5	26	64.0	A	286	SKAR38/30X4	315	315
	38	30	20		56.5	26	64.0	A	316	SKAR38/30X5	315	315

¹⁾ Pressure shown = item deliverable

³⁾ L = light series; ⁴⁾ S = heavy series

$$\frac{\text{PN (bar)}}{10} = \text{PN (MPa)}$$

*Please add the **suffixes** below according to the material/surface required.

Order code suffixes			
Material	Suffix surface and material	Example	Standard sealing material (no additional suffix needed)
Steel		SKAR16/12X2	NBR
Stainless Steel	71	SKAR16/12X271	VIT

SKA-ORB Weld nipple (orbital)

EO 24° O-ring weld nipple / butt weld (orbital)

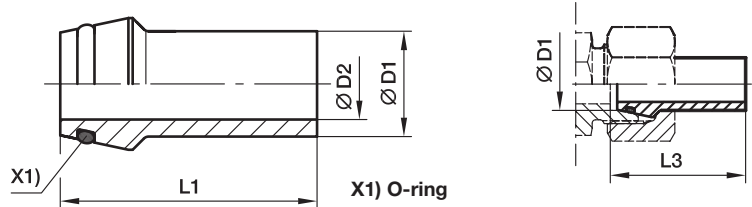

Series	D1	D2	L1	L3	recommended tube	Weight g/1 piece	Order code	PN (bar) ¹⁾ Stainless Steel
L ³⁾ /S ⁴⁾	10	6.0	37.5	38.5	10×1.5	13	SKA10X1.5ORB	358
	12	8.0	37.5	38.5	12×1.5	21	SKA12X1.5ORB	305
	12	8.0	37.5	38.5	12×2.0	255	SKA12X2ORB	393
L ³⁾	18	13.0	38.0	39.0	18×2.0	43	SKA18X2ORB	290
	22	17.0	38.5	39.5	22×2.0	50	SKA22X2ORB	250
	28	22.0	41.5	42.5	28×2.0	69	SKA28X2ORB	204
	42	36.0	47.5	50.0	42×3.0	160	SKA42X3ORB	182
S ⁴⁾	16	12.0	39.0	40.5	16×2.0	310	SKA16X2ORB	305
	20	14.0	45.0	47.0	20×3.0	640	SKA20X3ORB	358
	25	19.0	49.5	53.0	25×3.0	890	SKA25X3ORB	294

¹⁾ Pressure shown = item deliverable

³⁾ L = light series; ⁴⁾ S = heavy series

$$\frac{\text{PN (bar)}}{10} = \text{PN (MPa)}$$

*Please add the **suffixes** below according to the material/surface required.

Order code suffixes			
Material	Suffix surface and material	Example	Standard sealing material (no additional suffix needed)
Stainless Steel	71	SKA16X2ORB71	VIT

SKA-RB Tube bend weld nipple

EO 24° O-ring weld nipple / butt weld

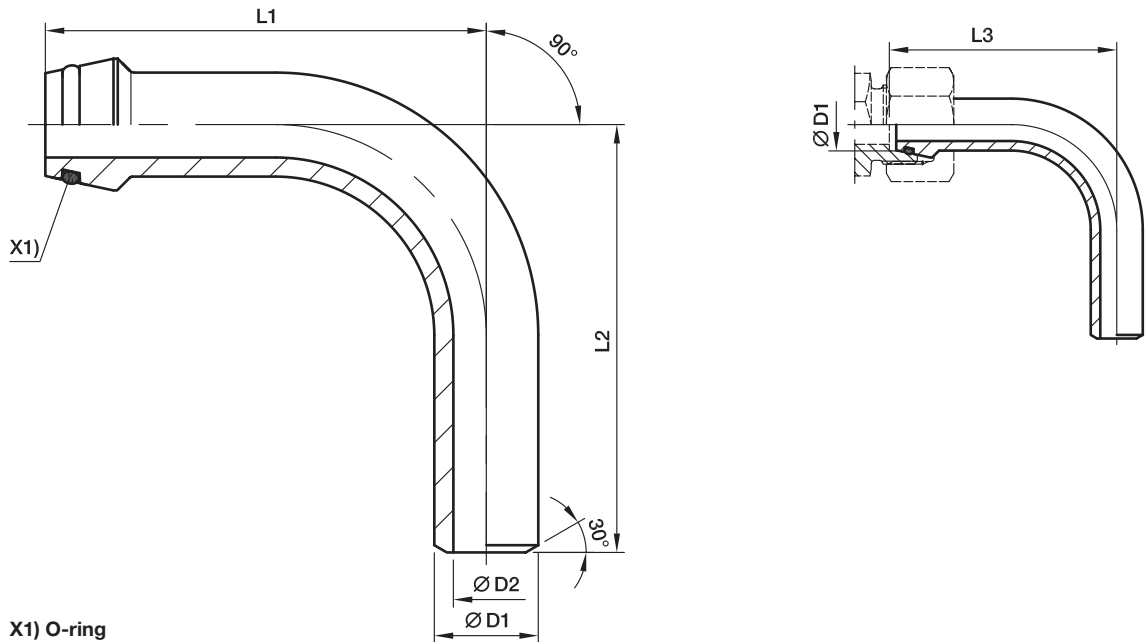

Series	D1	D2	L1	L2	L3	recommended tube	Weight g/1 piece	Order code	PN (bar) ¹⁾	
									Steel	Stainless Steel
S ⁴⁾	10	6	49	45	50.0	10×2.0	38	SKA10X2RB	460	447
	12	7	51	50	52.0	12×2.5	50	SKA12X2.5RB	476	463
	16	10	67	60	68.5	16×3.0	105	SKA16X3RB	400	400
	20	12	85	65	87.0	20×4.0	217	SKA20X4RB	400	400
	25	17	85	85	88.5	25×4.0	295	SKA25X4RB	379	369
	25	15	85	85	88.5	25×5.0	353	SKA25X5RB	400	400
	30	22	111	110	116.0	30×4.0	469	SKA30X4RB	323	314
	30	20	111	110	116.0	30×5.0	568	SKA30X5RB	393	383
	38	28	136	130	143.5	38×5.0	876	SKA38X5RB	315	315
	38	26	136	130	143.5	38×6.0	1045	SKA38X6RB	315	315

¹⁾Pressure shown = item deliverable

⁴⁾S = heavy series

$\frac{\text{PN (bar)}}{10} = \text{PN (MPa)}$

*Please add the **suffixes** below according to the material/surface required.

Order code suffixes			
Material	Suffix surface and material	Example	Standard sealing material (no additional suffix needed)
Steel		SKA16X3RB	NBR
Stainless Steel	71	SKA16X3RB71	VIT

OR O-ring for weld nipple

For Type: SKA, SKAR, SKA-RB

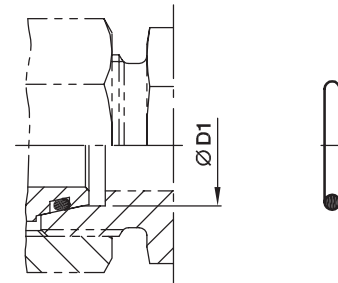

Series	D1 	O-ring NBR Shore-Hardness approx. 90	O-ring FKM Shore-Hardness approx. 90
L ³⁾	06	OR4.5X1.5X	OR4.5X1.5VITX
	08	OR6.5X1.5X	OR6.5X1.5VITX
	10	OR8.5X1.5X	OR8X1.5VITX
	12	OR10.5X1.5X	OR10X1.5VITX
	15	OR12.5X1.5X	OR12X2VITX
	18	OR16X2X	OR15X2VITX
	22	OR20X2X	OR20X2VITX
	28	OR26X2X	OR26X2VITX
	35	OR32X2.5X	OR32X2.5VITX
	42	OR39X2.5X	OR38X2.5VITX
S ⁴⁾	06	OR4.5X1.5X	OR4.5X1.5VITX
	08	OR6.5X1.5X	OR6.5X1.5VITX
	10	OR8.5X1.5X	OR8X1.5VITX
	12	OR10.5X1.5X	OR10X1.5VITX
	16	OR14X2X	OR13X2VITX
	20	OR17X2.5X	OR16.3X2.4VITX
	25	OR22X2.5X	OR20.3X2.4VITX
	30	OR27X2.5X	OR25.3X2.4VITX
	38	OR35X2.5X	OR33.3X2.4VITX

³⁾L = light series; ⁴⁾S = heavy series



EO[®] Ermeto Original
High Pressure
Hydraulic Flanges





Table of contents

	Page
Introduction	4
Design and construction	4
Methods of connection	5
How flange connections work	6
Assembly of flanges	7
Bolt torques for SAE flanges	8
Technical data	9
Order codes bolts and O-rings	10
Features, advantages and benefits	11
How to order	12
Visual index	13
SAE Flanges clamps	16
SAE Flange adapters	
EO 24° cone end.....	21
BSPP 60° cone end	25
Male NPT thread.....	27
O-Lok® ORFS end	28
Triple-Lok® 37° flare end.....	31
Butt weld end	34
Socket weld end.....	39
SAE Full flanges	
Female BSPP thread	42
Female NPT thread.....	46
EO 24° cone end.....	49
BSPP 60° cone end.....	51
Triple-Lok® 37° flare end.....	53
O-Lok® ORFS end	55
Butt weld end	57
Socket weld end.....	60
Complete flange connections.....	64
SAE Flange accessories	67
Gear pump flanges	
EO 24° cone end.....	75
O-Lok® ORFS end	78
Male/Female BSPP thread	80
Socket weld end	82
Special pump size flanges.....	83
Aluminium flanges	86
ISO 6164 Square flanges	88



Introduction

The 4 bolt flange connections conforming to ISO 6162-1/2 (SAE J518 Code 61/62) and ISO 6164 are proven, leak-free connections, especially suited for larger sizes, high pressures and assembly in tight quarters. Threaded port connections such as SAE straight thread O-ring and ISO 6149 are reasonably easy to assemble and provide 6000 psi and higher pressure capability up to size 12 (M27). Beyond this size the pressure rating starts to decrease and assembly torques increase rapidly.

The 4 bolt flange port connections provide ability to connect larger sizes and achieve higher-pressure capability at reasonable assembly torques. Because of the lower assembly torques compared to an equivalent size threaded port, these connections are well suited for tight quarters where wrench clearances are limited.

Design and construction

Parker 4 bolt flange products are designed to provide different methods of connecting a tube, hose, pipe or another fitting to the SAE standard 4-bolt flange port.

Flange fittings – All Parker flange fittings, except for those with square mounting hole pattern, are designed to conform to O-ring groove, bolt holes and bolt pattern dimensions of either ISO 6162-1 (SAE J518 Code 61), ISO 6162-2 (SAE J518 Code 62) and ISO 6164.

The counter fittings have a flat face (no O-ring groove) and the mounting holes are tapped. Where these fittings are used, the seal is in the mating part (flange adapter, flange hose fitting, flange block fitting, etc.) as shown in Fig. 1.

Dimensions other than the O-ring groove, bolt holes, bolt pattern, and the flange foot print are not governed by any industry standard. However, Parker product design follows common industry practice and sound engineering.

Flange clamps – Clamps are used for providing the holding power to the 4 bolt flange connection. They are offered in split and captive (one-piece) versions. The captive ones are also offered with either drilled or tapped bolt holes. The captive flange clamp with tapped holes is used while connecting a tube to another tube or a hose.

Parker flange clamps are forged for higher strength and durability. They meet all requirements of ISO 6162-1 (SAE J518 Code 61), ISO 6162-2 (SAE J518 Code 62) and ISO 6164. The split clamps make it easy to assemble the connection in close quarters. They also make removal of the flange head component, such as a hose assembly, easy by loosening all four bolts and removing one clamp half.

Connector plate – Connector plate is used as a middle plate to connect two flange heads with O-ring grooves, such as two hose assemblies with flange connection ends. The flat surface of the plate provides sealing surface on each side for the O-ring housed in the hose ends.

Spacer plate – Spacer plate provides access to the system fluid via the gage port on the side. The plate is sandwiched in the flange connection to provide this access.

Plugs – Plugs provide a means to block off the 4 bolt flange port with and without clamps, and to plug the end of a pipe (via welding).

Fig. 1 – Flange pad fitting

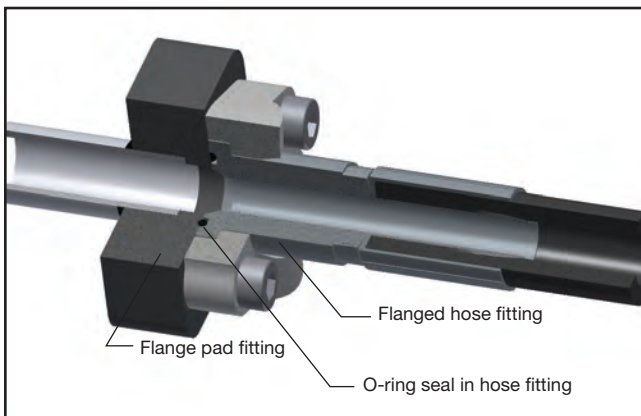

Methods of connection – Parker flange products

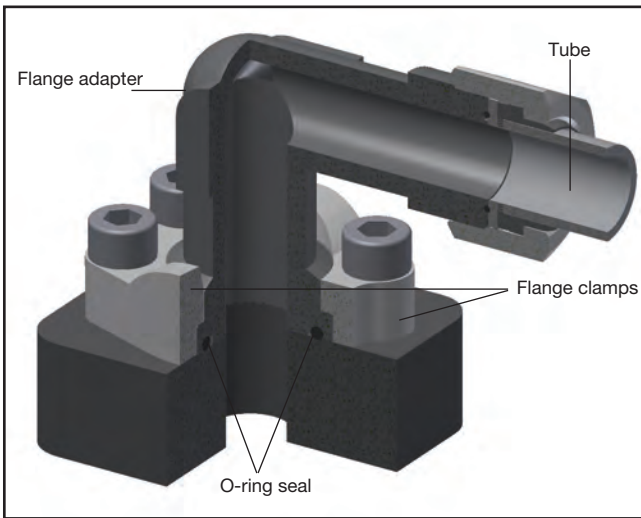

Connecting tube and hose via a threaded tube/hose end connection: The flange adapters provide means of connecting tubes or hoses to a 4 bolt flange port via threaded connection such as Seal-Lok (ORFS), Triple-Lok® (37° flare), etc.

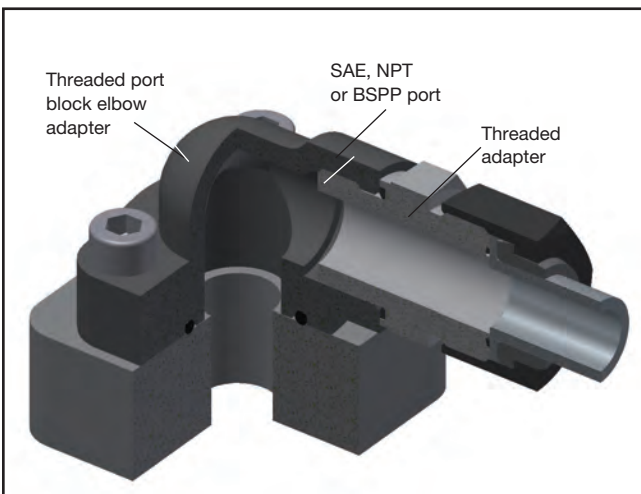

Connecting tube, hose and pipe via threaded port connection. The flange head and flange block conversion adapters provide the means of converting a flange port to either SAE, NPT or BSPP port. A user can then use appropriate threaded adapters to connect tube and hose, or connect threaded pipe directly into NPT and BSPP ports.

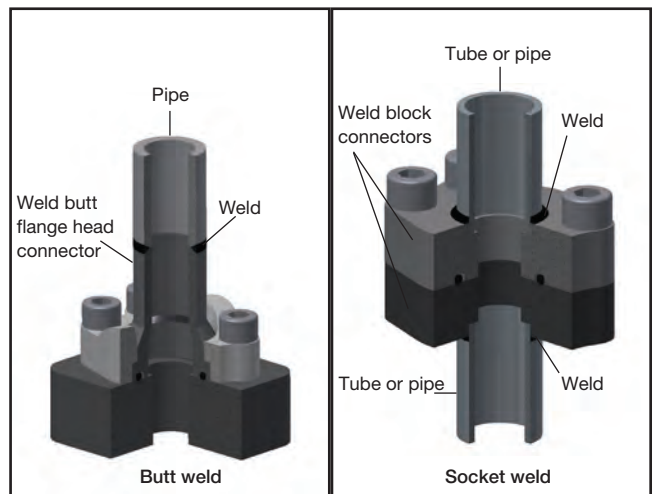

Connecting tube and pipe via welding. The flange head and flange block weld fittings provide the means of connecting tubes and pipes to 4 bolt flange port via socket welding for tubes and socket and butt welding for pipes.

N

How flange connections work

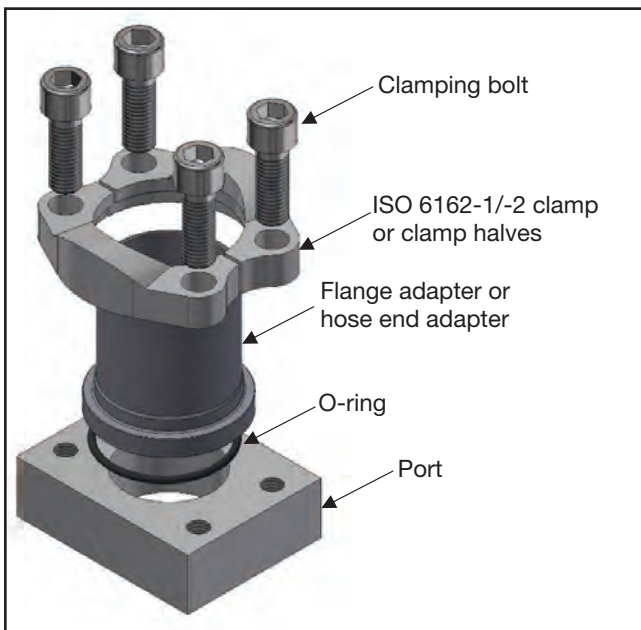

4 bolt flange connection ISO 6162-1/2 (SAE J518 Code 61/62) and ISO 6164 is a proven leak-free connection, especially suited for larger sizes. As a result, it has achieved worldwide acceptance.

The connection's success is in its simplicity. It is a static face seal using a high durometer O-ring (90 shore A) for the seal and clamps and bolts for holding power as shown here.

The (O-ring) seal is compressed between the bottom of the groove in the flange head and the flat surface of the port or flange pad, providing a reliable soft seal. The alternate seal plate has a high durometer bonded rubber seal on the inside edge, which compresses between the two flat surfaces, providing a soft seal with the same reliability. A metal-to-metal contact at the outer face of the flange with the port face keeps the seal from extruding under pressure. This metal-to-metal contact is maintained by the clamping force provided by tightening of the bolts via the clamps.

This simple design provides several advantages over threaded port connections, such as NPT, SAE, BSPP, ISO 6149, etc., in larger sizes:

- Ability to connect up to 5 inch O.D. tube (ISO 6162-1 only)
- Much lower tightening torque required from the four bolts compared to that required for equivalent size threaded port.
- Less tightening torque means smaller wrenches and wrench swing clearances – providing ease of assembly in tight quarters.
- Up to 6000 psi capability through 3" size (ISO 6162-2 only)
- Use up to 400 bar at the ISO 6164 flange sizes from 3/8" to 4".
- Single seal point between tube/pipe/hose assembly and the port
- Ease of disassembly through use of split clamps

Flanges



Assembly of flanges

- SAE flange adapters
- SAE 4 bolt flanges
- Gear pump flanges
- ISO 6164 Square flanges

1



- Make sure sealing surfaces are free of burrs, nicks, scratches or any contamination
- Lubricate the O-ring with system fluid or compatible lubricant
- Parker recommends to lubricate the bolts on contact surface (head) and lower third of thread (MOLYKOTE G-RAPID PLUS) just before use to avoid any contamination

2



- Position flange or flange adapter with clamp halves
- Placement of the spring washer on the bolt and connect both to the flange (only for gear pump flanges)

3

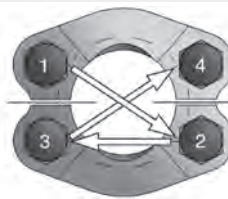

- Hand tighten bolts
- Torque bolts in diagonal sequence in small increments to the appropriate torque level listed in chart

4

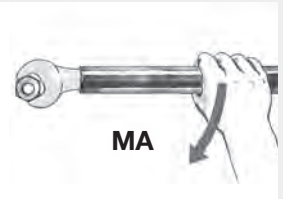

- Tighten bolts according to chart

Bolt torques for SAE-Flanges

Recommended torques for metric bolts ISO 4762-10.9 at the specified coefficient of friction $\mu_{tot}^{1)}$

for SAE Flange connections according ISO 6162-1 (3000 PSI Serie)

DN size	Flange size	Metric bolts (ISO 4762-10.9)	Torque $\mu_{tot} = 0.08$ Nm ²⁾	Torque $\mu_{tot} = 0.14$ Nm ²⁾
13	1/2	M8	23	36
19	3/4	M10	44	70
25	1	M10	44	70
32	1 1/4	M10	44	70
38	1 1/2	M12 / M14 ³⁾	75 / 90	120 / 140
51	2	M12 / M14 ³⁾	75 / 90	120 / 140
64	2 1/2	M12 / M14 ³⁾	75 / 90	120 / 140
76	3	M16	155	250
89	3 1/2	M16	155	250
102	4	M16	155	250
127	5	M16	155	250

for SAE Flange connections according ISO 6162-2 (6000 PSI Serie)

DN size	Flange size	Metric bolts (ISO 4762-10.9)	Torque $\mu_{tot} = 0.08$ Nm ²⁾	Torque $\mu_{tot} = 0.14$ Nm ²⁾
13	1/2	M8	23	36
19	3/4	M10	44	70
25	1	M12	75	120
32	1 1/4	M12 / M14 ³⁾	75 / 90	120 / 140
38	1 1/2	M16	155	250
51	2	M20	270	440
64	2 1/2	M24	450	700
76	3	M30	875	1420

Recommended torques for inch bolts (UNC thread) ANSI/ASME B18.3 at the specified coefficient of friction $\mu_{tot}^{1)}$

for SAE Flange connections according ISO 6162-1 (3000 PSI Serie)

DN size	Flange size	Inch bolts (ANSI/ASME B18.3)	Torque $\mu_{tot} = 0.17$ Nm ²⁾
13	1/2	5/16-18	45
19	3/4	3/8-16	80
25	1	3/8-16	80
32	1 1/4	7/16-14	130
38	1 1/2	1/2-13	210
51	2	1/2-13	210
64	2 1/2	1/2-13	210
76	3	5/8-11	300
89	3 1/2	5/8-11	300
102	4	5/8-11	300
127	5	5/8-11	300

for SAE Flange connections according ISO 6162-2 (6000 PSI Serie)

DN size	Flange size	Inch bolts (ANSI/ASME B18.3)	Torque $\mu_{tot} = 0.17$ Nm ²⁾
13	1/2	5/16-18	45
19	3/4	3/8-16	80
25	1	7/16-14	130
32	1 1/4	1/2-13	210
38	1 1/2	5/8-11	300
51	2	3/4-10	510

Gear Pump Flange recommend torque

Socket bolt bolt circle (LK)	Socket head cap bolts	Tightening torques Nm ²⁾
LK30	M6	10
LK35	M6	10
LK40	M6	10
LK51	M10	49
LK55	M8	25
LK56	M10	49
LK62	M10	49
LK72.5	M12	85

¹⁾ The specified friction coefficients are valid for supplied bolts by Parker.

For lubricated bolts (MOLYKOTE G-RAPIDE PLUS) the friction coefficient $\mu_{tot} = 0.08$ has been determined.

For Zinc flaked metric bolts (...ZNFLX) as delivered the friction coefficient $\mu_{tot} = 0.14$ has been determined.

For phosphated bolts we are referring to the ISO 6162.1 and -2 for $\mu_{tot} = 0.17$.

²⁾ Torque tolerances max. 10%, min. 0%

³⁾ Bolt size M14 is no longer mentioned in the ISO 6162-1 and -2 and should not be used for new constructions.

Technical data

Flange bolts

SAE Flanges according to ISO 6162-1 and -2 (SAE J518)

- metric bolts according to ISO 4762-10.9 (DIN 912-10.9) or higher quality
- UNC bolts according to ANSI/ASME B 18.3

UNC bolts acc. to ISO 6162-1 and -2 should not be used for new designs.

Square flanges according to ISO 6164 (1994)

- metric bolts according to ISO 4762-8.8 (DIN 912-8.8) or ISO 4762-10.9 (DIN 912-10.9)

Gear pump flanges

- metric bolts according to ISO 4762-8.8 (DIN 912-8.8)

Surface protection bolts

- ISO 4762-8.8 - zinc plated A3K (VZX)
- ISO 4762-10.9 - zinc flaked (ZNFLX)

We reserve the right to deliver black phosphated bolts ISO 4762-10.9, for achieving the best lead time if not specifically designated in the order.

Used Sealing

Materials

Flanges according **SAE J518 (ISO 6162-1 and -2), ISO 6164** and all **gear pump flanges** in this catalogue are sealed with an O-ring. The seals of our flanges are out of the following materials:

- NBR (e.g. perbunan) 90 shore A durometer is our standard seal material for hydraulic **steel** flange applications.
- FKM 85 or 90 shore A durometer is our standard seal material for hydraulic **stainless steel** flange applications.

Perbunan = registered trademark of Bayer

Dimensions

O-ring dimensions of ISO 6164 flanges, and gear pump flanges are shown direct on the product catalogue page. For all flanges according to **ISO 6162-1/2 (SAE J518 Code 61/62)** the O-ring dimension are according to the following table:

Nominal flange size	Nominal-inch tube size (in inches)	ISO 3601-1 SAE J515 O-ring	O-ring size number
13	1/2	18.64×3.53	210
19	3/4	24.99×3.53	214
25	1	32.92×3.53	219
32	1 1/4	37.69×3.53	222
38	1 1/2	47.22×3.53	225
51	2	56.74×3.53	228
64	2 1/2	69.44×3.53	232
76	3	85.32×3.53	237
89	3 1/2	98.02×3.53	241
102	4	110.72×3.53	245
127	5	136.12×3.53	253

Pressure ratings

The maximum recommended working pressure is indicated for each article.

Before using a part, please take notice of the pressure ratings.

All pressure indications are based on a working temperature from -20° celsius up to +100° celsius (resp. ambient temperature from -40° celsius up to +120° celsius). Outside of this temperature range the physical properties of the material is affected and the maximum recommended working pressure is reduced.

The indicated working pressures refer only to the flange itself. For the tubes, fittings and connections the pressure ratings of the specific manufacturer must also be taken into account.

Materials

SAE flanges according to ISO 6162-1 and -2 (SAE 518)

Flange clamps, flange adapter and forged 4 bolt flanges are made of the material ST 52.3 or compatible for **steel** construction. For **stainless steel** constructions we are using for flange clamps, flange adapters and 4 bolt forged flanges the material 1.4401 (316) or compatible. For special applications it is also possible to get the flange adapters made from the material 1.4571 (316Ti).

Square flanges according to ISO 6164 (1994)

Steel construction: ST52.3, C40 or compatible
 Stainless steel construction: 1.4571 (316Ti) or compatible

Gear pump flanges

Cast steel construction: GTW40 or compatible
 Steel construction: ST52.3, 11SMnPb30 or compatible
 Forged steel construction: ST52.3 or compatible

If different materials are used for manufacturing, this will be shown on the catalogue product page.

Surface protection

All surface order possibilities are described on each catalogue page!

Surface possibilities are:

1. Oil dipped, phosphated
2. Cr(VI)-free surface protection CF (type CF, CR3, CFL) with same or better corrosion resistance than yellow zinc chromated surface protection (A3C).

Order codes bolts and O-rings

Bolts for flanges

according ISO 6162-1 and -2 (SAE J518)

Nominal flange size			Bolts for flanges and flange halves		Bolts for full flanges	
Series	ISO	SAE	metr. Order code	UNC Order code	metr. Order code	UNC Order code
3000 PSI	13	1/2	ZYLS8X25109ZNFLX	UNC5/16-18X11/4	ZYLS8X30109ZNFLX *	UNC5/16-18X11/4
3000 PSI	19	3/4	ZYLS10X30109ZNFLX	UNC3/8-16X11/4	ZYLS10X35109ZNFLX *	UNC3/8-16X11/2 *
3000 PSI	25	1	ZYLS10X30109ZNFLX	UNC3/8-16X11/4	ZYLS10X35109ZNFLX *	UNC3/8-16X11/2 *
3000 PSI	32	1 1/4	ZYLS10X30109ZNFLX	UNC7/16-14X11/2	ZYLS10X40109ZNFLX *	UNC7/16-14X11/2
3000 PSI	32	1 1/4	ZYLS10X35109ZNFLX *	—	—	—
3000 PSI	32	1 1/4	ZYLS12X35109ZNFLX *	—	—	—
3000 PSI	38	1 1/2	ZYLS12X35109ZNFLX	UNC1/2-13X11/2	ZYLS12X45109ZNFLX *	UNC1/2-13X13/4 *
3000 PSI	38	1 1/2	ZYLS14X35109ZNFLX *	—	—	—
3000 PSI	51	2	ZYLS12X35109ZNFLX	UNC1/2-13X11/2	ZYLS12X45109ZNFLX *	UNC1/2-13X13/4 *
3000 PSI	51	2	ZYLS14X35109ZNFLX *	—	—	—
3000 PSI	64	2 1/2	ZYLS12X40109ZNFLX	UNC1/2-13X13/4	ZYLS12X45109ZNFLX *	UNC1/2-13X13/4 *
3000 PSI	64	2 1/2	ZYLS14X35109ZNFLX *	UNC1/2-13X11/2 *	—	—
3000 PSI	76	3	ZYLS16X50109ZNFLX	UNC5/8-11X13/4	ZYLS16X55109ZNFLX *	UNC5/8-11X21/4 *
3000 PSI	76	3	ZYLS16X45109ZNFLX *	UNC5/8-11X2 *	—	—
3000 PSI	89	3 1/2	ZYLS16X50109ZNFLX	UNC5/8-11X2	ZYLS16X55109ZNFLX *	UNC5/8-11X21/4 *
3000 PSI	89	3 1/2	ZYLS16X45109ZNFLX *	—	—	—
3000 PSI	102	4	ZYLS16X50109ZNFLX	UNC5/8-11X2	ZYLS16X55109ZNFLX *	UNC5/8-11X21/4 *
3000 PSI	102	4	ZYLS16X45109ZNFLX *	—	—	—
3000 PSI	127	5	ZYLS16X55109ZNFLX	UNC5/8-11X21/4	ZYLS16X55109ZNFLX	UNC5/8-11X21/4
3000 PSI	127	5	ZYLS16X50109ZNFLX *	UNC5/8-11X2 *	—	—
Serie	ISO	SAE	metr.	UNC	metr.	UNC
6000 PSI	13	1/2	ZYLS8X30109ZNFLX	UNC5/16-18X11/4	ZYLS8X30109ZNFLX	UNC5/16-18X11/4
6000 PSI	19	3/4	ZYLS10X35109ZNFLX	UNC3/8-16X11/2	ZYLS10X35109ZNFLX	UNC3/8-16X11/2
6000 PSI	25	1	ZYLS12X45109ZNFLX	UNC7/16-14X13/4	ZYLS12X45109ZNFLX	UNC7/16-14X11/2 *
6000 PSI	25	1	—	UNC7/16-14X11/2 *	—	—
6000 PSI	32	1 1/4	ZYLS12X45109ZNFLX	UNC1/2-13X13/4	ZYLS12X50109ZNFLX	UNC1/2-13X13/4
6000 PSI	32	1 1/4	ZYLS14X50109ZNFLX *	—	ZYLS14X50109ZNFLX *	—
6000 PSI	38	1 1/2	ZYLS16X55109ZNFLX	UNC5/8-11X21/4	ZYLS16X55109ZNFLX	UNC5/8-11X21/4
6000 PSI	38	1 1/2	—	UNC5/8-11X2 *	—	—
6000 PSI	51	2	ZYLS20X70109ZNFLX	UNC3/4-10X23/4	ZYLS20X70109ZNFLX	UNC3/4-10X23/4
6000 PSI	51	2	ZYLS20X65109ZNFLX *	UNC3/4-10X21/2 *	—	—
6000 PSI	64	2 1/2	ZYLS24X75109ZNFLX *	—	ZYLS24X90109ZNFLX *	—
6000 PSI	76	3	ZYLS30X90109ZNFLX	—	ZYLS30X110109ZNFLX *	—

* = are not implemented in the ISO 6162 -1 and ISO 6162-2.

Bolts for gear pump flanges

(BFG, BFW)

Typ	Bolts Order code	Description
BFG (10L-28L)	ZYLS6X22VZX	4 pieces
BFG (20S)	ZYLS8X25VZX	4 pieces

Type	LK	Bolts		Description
		Order code	Order code	
BFW 10L	35	ZYLS6X22VZX	ZYLS6X35VZX	2 Pieces of each bolt
BFW 12L	35	ZYLS6X22VZX	ZYLS6X35VZX	2 Pieces of each bolt
BFW 15L	35	ZYLS6X22VZX	ZYLS6X35VZX	2 Pieces of each bolt
BFW 16S	35	ZYLS6X22VZX	ZYLS6X40VZX	2 Pieces of each bolt
BFW 20S	35	ZYLS6X22VZX	ZYLS6X45VZX	2 Pieces of each bolt
BFW 15L	40	ZYLS6X22VZX	—	4 Pieces
BFW 18L	40	ZYLS6X22VZX	—	4 Pieces
BFW 22L	40	ZYLS6X22VZX	—	4 Pieces
BFW 28L	40	ZYLS6X20VZX	ZYLS6X50VZX	2 Pieces of each bolt
BFW 35L	40	ZYLS6X22VZX	ZYLS6X60VZX	2 Pieces of each bolt
BFW 20S	40	ZYLS6X22VZX	ZYLS6X45VZX	2 Pieces of each bolt
BFW 35L	55	ZYLS8X25VZX	ZYLS8X60VZX	2 Pieces of each bolt
BFW 42L	55	ZYLS8X25VZX	ZYLS8X70VZX	2 Pieces of each bolt
BFW 20S	55	ZYLS8X25VZX	ZYLS8X50VZX	2 Pieces of each bolt
BFW 25S	55	ZYLS8X25VZX	ZYLS8X55VZX	2 Pieces of each bolt
BFW 30S	55	ZYLS8X25VZX	ZYLS8X50VZX	2 Pieces of each bolt

O-rings for flanges

SAE J518

ISO (DN)	SAE (Inch)	O-ring	
		NBR Order code	FKM Order code
13	1/2	OR18.64X3.53X	OR18.64X3.53VITX
19	3/4	OR25X3.53X	OR25X3.53VITX
25	1	OR32.92X3.53X	OR32.92X3.53VITX
32	1 1/4	OR37.69X3.53X	OR37.69X3.53VITX
38	1 1/2	OR47.22X3.53X	OR47.22X3.53VITX
51	2	OR56.75X3.53X	OR56.75X3.53VITX
64	2 1/2	OR69.44X3.53X	OR69.44X3.53VITX
76	3	OR85.32X3.53X	OR85.32X3.53VITX
89	3 1/2	OR98.02X3.53X	OR98.02X3.53VITX
102	4	OR110.72X3.53X	OR110.72X3.53VITX
127	5	OR136.12X3.53X	OR136.12X3.53VITX

O-rings for hydraulic flanges

(BFG, BFW)

LK	O-ring size	Order code
35	20x2.5	OR20X2.5X
40	26x2.5	OR26X2.5X
55	32x2.5	OR32X2.5X

Features, advantages and benefits

- 1. Manufacture** – ISO 6162-1/2 fittings conform to SAE J518 and Code 61/62. This international standards control dimensions and tolerances of high pressure hydraulic flanges.
- 2. Available configurations** – Over 60 different configurations are standard in a range of sizes. The breadth of product provides flexibility in plumbing to insure the best solution possible.
- 3. Materials** – All configurations are available as standard in steel, with commonly used styles available in stainless steel.
- 4. Available sizes** – Most configurations are available as standard in 1/2" through 2" with sizes as large as 5" available in some styles.
- 5. Construction** – Parker offers a completely forged steel product line to insure our products hold up in the most rigorous applications.
- 6. Envelope size** – Forged construction provides a compact design compared to flanges machined from block steel.
- 7. Pressure ratings** – ISO 6162-1/2 fittings and flanges have pressure ratings up to 6000 psi. The recommended working pressure can be found directly on each catalogue page. This is a quick and easy way to verify the part in question meets the application pressure requirements.
- 8. Flange kits** – To reduce ordering and assembly errors, kits that include mounting hardware (bolts, O-ring, and if needed flange halves) are available.
- 9. Mounting hardware** – Bolts used in mounting kits are designated at least grade 8.8 to provide long dependable use.

How to order

SAE Flange adapters

WFS SAE 90° Elbow flange adapter

SAE Flange / EO 24° cone end
(ISO 6162-1/-2)

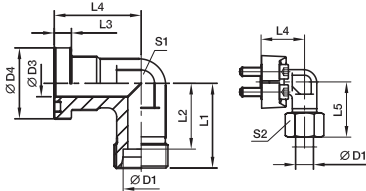

Nom. flange size		D1 ²⁾	Screws												Weight (steel) kg/piece	Order code*	PN (bar) ¹⁾	
SAE (in.)	ISO (DN)	Ø	D3	D4	L1	L2	L3	L4	L5	S1	S2	(metr.)	(unc.)	CF			71	
1/2	13	12S	12	30.2	50	42.5	6.7	44	58.5	22	24	M 08x25	5/16x1 1/4	0.38	WFS32/12S	210	210	
1/2	13	15L	12	30.2	36	29.0	6.7	36	44.0	24	27	M 08x25	5/16x1 1/4	0.40	WFS32/15L	315	315	
1/2	13	16S	12	30.2	38	29.5	6.7	36	48.0	24	30	M 08x25	5/16x1 1/4	0.43	WFS32/16S	350	350	
1/2	13	18L	12	30.2	50	42.5	6.7	44	59.0	22	32	M 08x25	5/16x1 1/4	0.44	WFS32/18L	315	315	
3/4	19	16S	19	38.1	64	55.5	6.7	53	73.5	27	30	M 10x30	3/8x1 1/4	0.60	WFS33/16S	350	350	
3/4	19	18L	19	38.1	39	31.5	6.7	42	48.0	30	32	M 10x30	3/8x1 1/4	0.66	WFS33/18L	315	315	
3/4	19	22L	19	38.1	41	33.5	6.7	42	50.0	30	36	M 10x30	3/8x1 1/4	0.66	WFS33/22L	160	160	
3/4	19	20S	17	38.1	43	32.5	6.7	42	54.0	30	36	M 10x30	3/8x1 1/4	0.76	WFS33/20S	350	350	
3/4	19	25S	17	38.1	45	33.0	6.7	42	57.0	30	46	M 10x30	3/8x1 1/4	0.89	WFS33/25S	350	350	
1	25	20S	20	44.5	65	54.5	8.0	60	77.0	34	36	M 10x30	3/8x1 1/4	0.7	WFS34/20S	350	350	
1	25	22L	18	44.5	65	57.5	8.0	60	74.0	34	36	M 10x30	3/8x1 1/4	0.7	WFS34/22L	360	360	
1	25	28L	25	44.5	44	36.5	8.0	45	53.0	36	41	M 10x30	3/8x1 1/4	0.7	WFS34/28L	360	360	
1	25	25S	20	44.5	48	36.5	8.0	45	57.0	36	46	M 10x30	3/8x1 1/4	0.7	WFS34/25S	360	360	
1	25	30S	24	44.5	50	36.5	8.0	45	63.0	36	50	M 10x30	3/8x1 1/4	0.7	WFS34/30S	360	360	
1	25	35L	32	50.8	57	46.5	8.0	50	68.0	41	50	M 10x35	3/8x1 1/4	0.7	WFS35/35L/10³⁾	360	360	
1 1/4	32	25S	27	50.8	55	43.0	8.0	50	67.0	41	46	M 10x35	3/8x1 1/4	0.7	WFS35/25S/10	360	360	
1 1/4	32	30S	28	50.8	57	43.5	8.0	50	70.0	41	50	M 10x35	3/8x1 1/4	1.1	WFS35/30S/10	360	360	
1 1/4	32	38S	28	50.8	59	43.0	8.0	50	74.0	46	60	M 10x35	3/8x1 1/4	1.1	WFS35/38S	200	200	
1 1/4	32	35L	32	50.8	57	46.5	8.0	50	68.0	41	50	M 12x40	7/16x1 1/2	1.3	WFS35/35L/10	160	160	
1 1/4	32	25S	27	50.8	55	43.0	8.0	50	67.0	41	46	M 12x40	7/16x1 1/2	1.35	WFS35/35S/10	200	200	
1 1/4	32	30S	28	50.8	57	43.5	8.0	50	70.0	41	50	M 12x40	7/16x1 1/2	1.40	WFS35/30S	200	200	
1 1/4	32	38S	28	50.8	59	43.0	8.0	50	74.0	41	60	M 12x40	7/16x1 1/2	1.53	WFS35/38S	200	200	
1 1/2	38	35L	30	60.3	78	67.5	8.0	66	83.0	50	50	M 12x35	1/2x1 1/2	1.55	WFS36/35L	160	160	
1 1/2	38	42L	36	60.3	58	47.0	8.0	55	70.0	50	60	M 12x35	1/2x1 1/2	1.60	WFS36/42L	160	160	
1 1/2	38	38S	36	60.3	64	48.0	8.0	55	79.0	50	60	M 12x35	1/2x1 1/2	1.95	WFS36/38S	200	200	

¹⁾ Pressure shown = Item deliverable

²⁾ L = light series; S = heavy series

PN (bar) = PN (MPa)

10

Delivery without nut and ring.

Information on ordering complete fittings or alternative sealing materials see page N11.

³⁾ Order code for the elbow flange adapter assembled with FHS35/10CFX and M10x35 screws.

*Please add the suffixes below to the material/surface required

Material	Standard sealing material (no additional suffix needed)
Steel, zinc plated, Cr(VI)-free	MDCFU
Stainless steel	VIT



Catalogue 4100-10/UK

The corresponding order variant is contained in the table printed at the bottom of every page in the catalogue.



The right way to order made easy!

Step 1 Selecting order code

1. All flange sizes available in our program of supply are clearly listed in the index at the front of this catalogue.
2. Open the catalogue at the corresponding page containing detailed information of the product of your choice.
3. Select the required flange size!
The basic order code is printed in bold type on the right-hand side of the table of dimensions.

Example: **WFS34/30S**

Step 2 Selecting material and surface ...

Now simply add the corresponding ID code for the surface and material variant of the product you require to the basic order code.
This ID code is contained in the table printed at the bottom of every page.

Example: WFS34/30S + CFX = **WFS34/30SCFX**

4. **Ordering single parts**
Example: single part, Cr(VI)-free galvanized
WFS34/30S + CFX = **WFS34/30SCFX**
5. **Ordering complete types**
Example: order incl. splitflanges, metric-bolt pack and O-ring
WFS34/30S + OMDCF = **WFS34/30SOMDCF**
6. **Order containing nut and cutting ring**
Example: flange incl. splitflanges, metric-bolt pack, O-ring, nut and cutting ring
WFS34/30S + CF = **WFS34/30SCF**
7. **Order with functional nut**
Example: flange incl. splitflanges, metric-bolt pack, O-ring, nut and functional nut
WFS34/30 (+Z) S + CF = **WFS34/30ZSCF**
8. **Other sealing materials**
Example: flange made of steel incl. splitflanges, metric-bolt pack and O-ring made of **FKM**.
WFS34/30S + VITOMDCF = **WFS34/30SVITOMDCF**

Example: flange made of stainless steel incl. splitflanges, metric-bolt pack and O-ring made of **NBR** (for example, Perbunan).
WFS34/30S + NBRMD71 = **WFS34/30SNBROMD71**

Perbunan = registered trademark of Bayer

SAE Flange clamps



FHS – p. N16

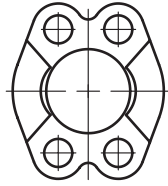

FUS – p. N17

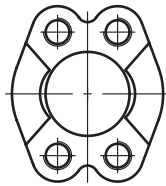

FUSM – p. N18



FHSF – p. N19

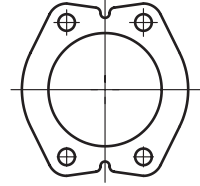

FUSF – p. N20

SAE Flange adapters

EO 24° cone end

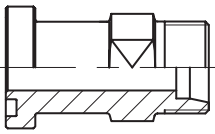

GFS – p. N21

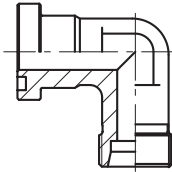

WFS – p. N23

BSPP 60° cone end

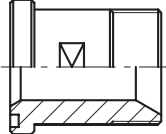

GFS-G – p. N25

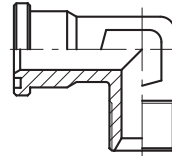

WFS-G – p. N26

Male NPT thread

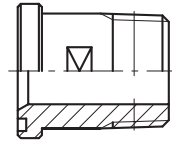

GFS-N – p. N27

O-Lok® ORFS end

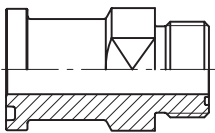

L(O)HQ – p. N28

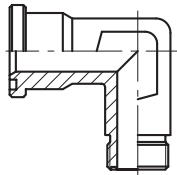

L(O)EMQ – p. N29

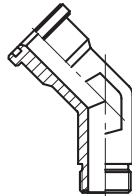

L(O)VQ – p. N30

Triple-Lok® 37° flare end

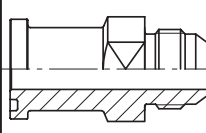

XHQ – p. N31

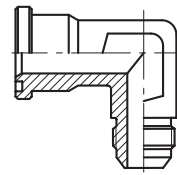

XEMQ – p. N32

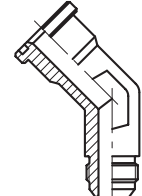

XVQ – p. N33

Butt weld end

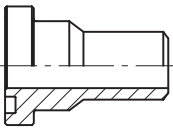

ASR – p. N34

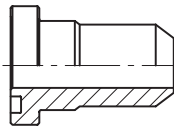

AS – p. N35

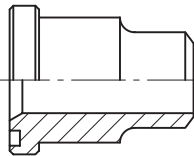

ASL – p. N37

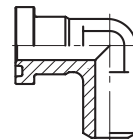

WAS – p. N38

Socket weld end

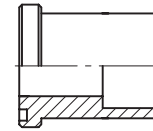

ES – p. N39

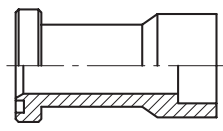

ESL – p. N41

SAE Full flanges

Female BSPP thread

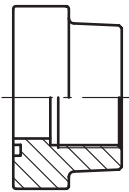

PFF-G – p. N42

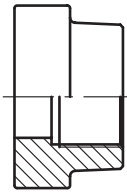

PCFF-G – p. N43



PAFSF-G – p. N44

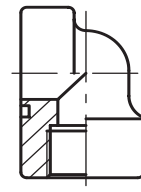

PEFF-G – p. N45

Female NPT thread

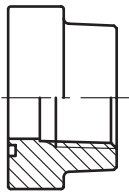

PFF-N – p. N46

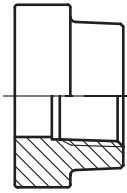

PCFF-N – p. N47

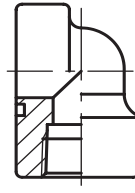

PEFF-N – p. N48

N

Visual index

SAE Full flanges

EO 24° cone end

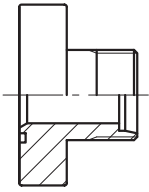

PFF-..S/L – p. N49

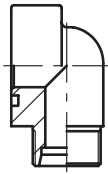

PAFG-90M – p. N50

BSPP 60° cone end

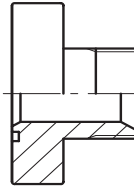

PAFG-G – p. N51



PAFG-90G – p. N52

Triple-Lok® 37° flare end

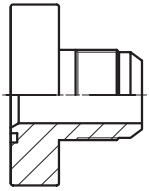

PAFG-X – p. N53

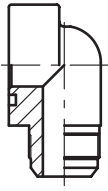

PAFG-90X – p. N54

O-Lok® ORFS end

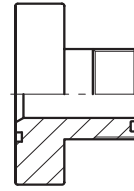

PAFG-L – p. N55

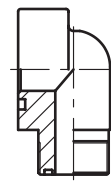

PAFG-90L – p. N56

Butt weld end

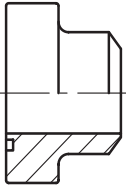

PAFS-B – p. N57

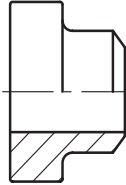

PGFS-B – p. N58

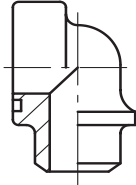

PAFS-90B – p. N59

Socket weld end

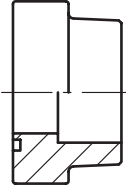

PAFS-S – p. N60

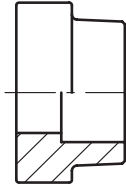

PGFS-S – p. N61



PAFSF-S – p. N62

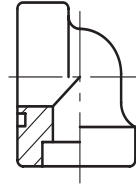

PAFS-90S – p. N63

Complete flange connections

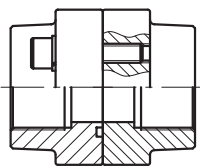

PDFS-G – p. N64

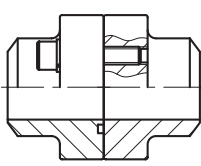

PDFS-B – p. N65

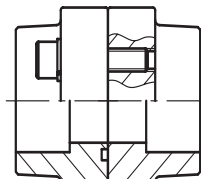

PDFS-S – p. N66

SAE Flange accessories

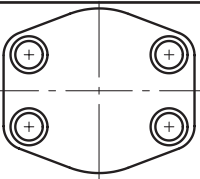

PCFF – p. N67

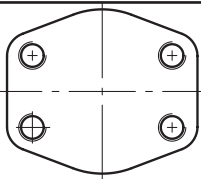

PCCFF – p. N68

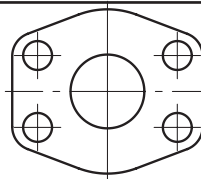

CPM – p. N69

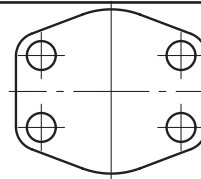

AP – p. N70



PMQ flat – p. N71

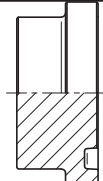

PMQ – p. N72

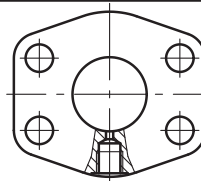

PAGL-(G/M) – p. N73

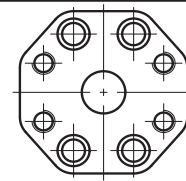

PRF – p. N74

Gear pump flanges

EO 24° cone end

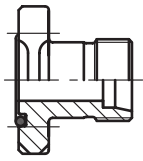

BFG – p. N75



BFW – p. N76



BFW3 – p. N77

O-Lok® ORFS end

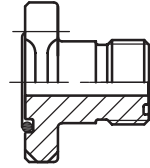

BFGL – p. N78

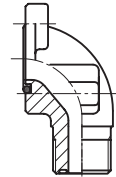

BFWL – p. N79

Male/Female BSPP thread

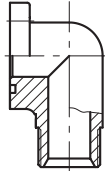

BFW-G – p. N80



BFW-GI – p. N81

Socket weld end

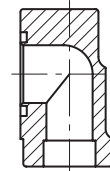

BFW-S – p. N82

Special pump size flanges

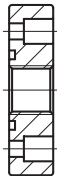

PF – p. N83

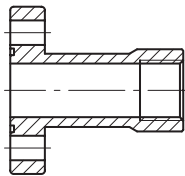

PFL – p. N83

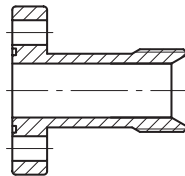

PFE – p. N84

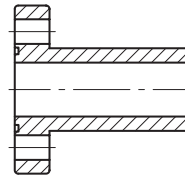

PFB – p. N84

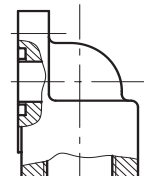

BFW3-G – p. N85

Aluminium flanges

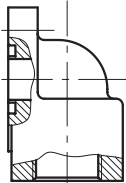

PWDS-G – p. N86

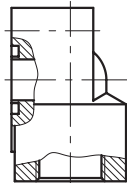

PWDA – p. N87

ISO 6164 Square flanges



PSFC – p. N88

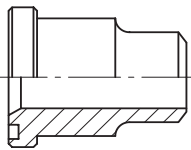

PSFA-B – p. N89

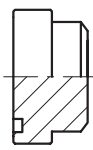

PSFP – p. N90

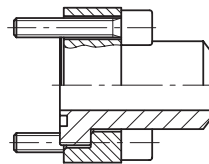

PSF-B – p. N91

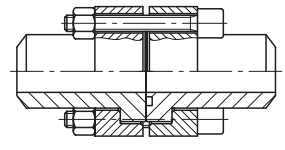

PDSF-B – p. N92

FHS SAE Split flange halves

ISO 6162-1/-2

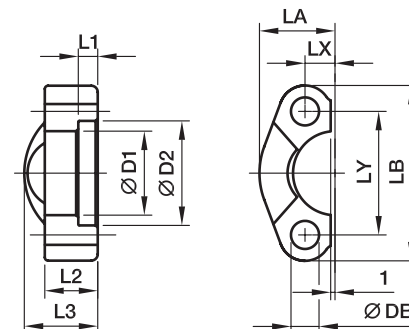

3000 PSI Series

Nom. flange size												Bolts		Weight (steel) kg/piece	Order code*	PN (bar) ¹⁾	
SAE (in.)	ISO (DN)	D1	D2	L1	L2	L3	LA	LB	LX	LY	DB	(metr.)	(unc.)			CF	SS
1/2	13	24.3	31.0	6.2	13	19	23.0	54.0	8.7	38.1	8.9	M 08×25	5/16×1 1/4	0.07	FHS32	345	345
3/4	19	32.2	38.9	6.2	14	22	25.9	65.0	11.1	47.6	10.6	M 10×30	3/8×1 1/4	0.09	FHS33	345	345
1	25	38.5	45.2	7.5	16	24	29.2	69.9	13.1	52.4	10.6	M 10×30	3/8×1 1/4	0.11	FHS34	345	345
1 1/4	32	43.7	51.6	7.5	16	22	36.3	79.4	15.1	58.7	10.6	M 10×35	–	0.17	FHS35/10	276	276
1 1/4	32	43.7	51.6	7.5	16	22	36.3	79.4	15.1	58.7	12.0	–	7/16×1 1/2	0.17	FHS35/12	276	276
1 1/4	32	43.7	51.6	7.5	16	22	36.3	79.4	15.1	58.7	12.5	M 12×35	–	0.17	FHS35	276	276
1 1/2	38	50.8	61.1	7.5	16	25	41.1	93.8	17.9	69.9	13.5	M 12×35	1/2×1 1/2	0.24	FHS36	207	207
1 1/2	38	50.8	61.1	7.5	16	25	41.1	93.8	17.9	69.9	14.5	M 14×35	–	0.24	FHS36/14	207	207
2	51	62.8	72.3	9.0	16	26	48.2	101.6	21.4	77.8	13.5	M 12×35	1/2×1 1/2	0.27	FHS38/12	207	207
2	51	62.8	72.3	9.0	16	26	48.2	101.6	21.4	77.8	14.5	M 14×35	–	0.27	FHS38	207	207
2 1/2	64	74.9	84.9	9.0	19	38	54.1	114.3	25.4	88.9	13.5	M 12×40	1/2×1 3/4	0.45	FHS310	172	172
2 1/2	64	74.9	84.9	9.0	19	38	54.1	114.3	25.4	88.9	14.5	M 14×40	–	0.45	FHS310/14	172	172
3	76	90.9	102.4	9.0	22	41	65.3	135.0	31.0	106.4	16.7	M 16×45	5/8×1 3/4	0.71	FHS312	138	138
3 1/2	89	102.4	115.0	10.7	22	28	68.6	152.4	34.9	120.7	16.7	M 16×45	5/8×2	0.65	FHS314	34	34
4	102	115.1	127.8	10.7	25	35	74.9	162.0	38.9	130.2	16.7	M 16×50	5/8×2	0.87	FHS316	34	34
5	127	140.5	153.2	10.7	28	41	89.4	184.2	46.0	152.4	16.7	M 16×50	5/8×2 1/4	1.25	FHS320	34	34

6000 PSI Series

1/2	13	24.6	32.5	7.2	16	22	24.0	56.4	9.1	40.5	9.0	M 08×30	5/16×1 1/4	0.08	FHS62	420	420
3/4	19	32.5	42.0	8.3	19	28	30.0	72.0	11.9	50.8	11.0	M 10×35	3/8×1 1/2	0.18	FHS63	420	420
1	25	38.8	48.4	9.0	24	33	34.8	81.0	13.9	57.2	13.0	M 12×45	–	0.27	FHS64	420	420
1	25	38.9	48.4	9.0	24	33	34.8	81.0	13.9	57.2	12.0	–	7/16×1 3/4	0.27	FHS64/12	420	420
1 1/4	32	44.5	54.8	9.8	27	38	38.6	95.3	15.9	66.6	15.0	M 14×50	–	0.27	FHS65	420	420
1 1/4	32	44.5	54.8	9.8	27	38	38.6	95.3	15.9	66.6	13.0	M 12×45	1/2×1 3/4	0.27	FHS65/12	420	420
1 1/2	38	51.6	64.3	12.1	30	43	47.5	112.8	18.3	79.3	17.0	M 16×55	5/8×2 1/4	0.40	FHS66	420	420
2	51	67.6	80.2	12.1	37	52	56.9	133.4	22.2	96.8	22.0	M 20×65	3/4×2 3/4	0.40	FHS68	420	420
2 1/2	64	90.0	108.0	20.0	45	45	75.1	180.0	29.4	123.8	25.0	M 24×75	–	0.68	FHS610	420	420
3	76	115.0	132.5	25.0	55	55	99.1	215.0	35.7	152.4	31.5	M 30×90	–	1.05	FHS612	420	420

¹⁾Pressure shown = Item deliverable

 PN (bar) = PN (MPa)
 10

 *Please add the **suffixes** below according to the material/surface required.

Order code suffixes			
Material	Suffix surface and material	Example	Description
Steel, zinc plated, Cr(VI)-free	CF	FHS32CFX	only flange half
Stainless steel	SS	FHS32SSX	only flange half

FUS SAE Full flanges

ISO 6162-1/-2

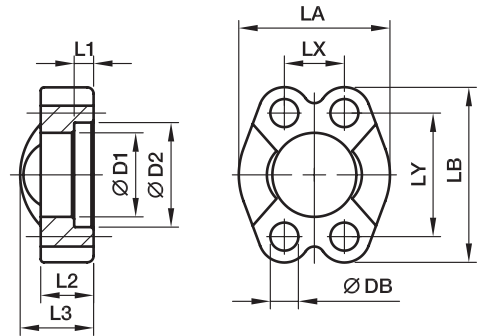

3000 PSI Series

Nom. flange size												Bolts		Weight (steel) kg/piece	Order code*	PN (bar) ¹⁾	
SAE (in.)	ISO (DN)	D1	D2	L1	L2	L3	LA	LB	LX	LY	DB	(metr.)	(unc.)			CF	SS
1/2	13	24.3	31.0	6.2	13	19	46	54.0	17.5	38.1	8.9	M 08×25	5/16×1 1/4	0.13	FUS32	345	345
3/4	19	32.2	38.9	6.2	14	22	52	65.0	22.3	47.6	10.6	M 10×30	3/8×1 1/4	0.18	FUS33	345	345
1	25	38.5	45.2	7.5	16	24	59	69.9	26.2	52.4	10.6	M 10×30	3/8×1 1/4	0.22	FUS34	345	345
1 1/4	32	43.7	51.6	7.5	16	22	73	79.4	30.2	58.7	10.6	M 10×35	-	0.30	FUS35/10	276	276
1 1/4	32	43.7	51.6	7.5	16	22	73	79.4	30.2	58.7	12.0	-	7/16×1 1/2	0.29	FUS35/12	276	276
1 1/4	32	43.7	51.6	7.5	16	22	73	79.4	30.2	58.7	12.5	M 12×35	-	0.29	FUS35	276	276
1 1/2	38	50.8	61.1	7.5	16	25	83	93.8	35.8	69.9	13.5	M 12×35	1/2×1 1/2	0.45	FUS36	207	207
1 1/2	38	50.8	61.1	7.5	16	25	83	93.8	35.8	69.9	14.5	M 14×35	-	0.44	FUS36/14	207	207
2	51	62.8	72.3	9.0	16	26	97	101.6	42.8	77.8	13.5	M 12×35	1/2×1 1/2	0.53	FUS38/12	207	207
2	51	62.8	72.3	9.0	16	26	97	101.6	42.8	77.8	14.5	M 14×35	-	0.51	FUS38	207	207
2 1/2	64	74.9	84.9	9.0	19	38	109	114.3	50.8	88.9	13.5	M 12×40	1/2×1 3/4	0.85	FUS310	172	172
2 1/2	64	74.9	84.9	9.0	19	38	109	114.3	50.8	88.9	14.5	M 14×40	-	0.82	FUS310/14	172	172
3	76	90.9	102.4	9.0	22	41	131	135.0	61.9	106.4	16.7	M 16×45	5/8×1 3/4	1.30	FUS312	138	138
3 1/2	89	102.4	115.0	10.7	22	28	140	152.4	69.9	120.7	16.7	M 16×45	5/8×2	1.57	FUS314	34	34
4	102	115.1	127.8	10.7	25	35	150	162.0	77.8	130.2	16.7	M 16×50	5/8×2	1.82	FUS316	34	34
5	127	140.5	153.2	10.7	28	41	180	184.2	92.1	152.4	16.7	M 16×50	5/8×2 1/4	2.63	FUS320	34	34

6000 PSI Series

1/2	13	24.6	32.5	7.2	16	22	48	56.4	18.2	40.5	8.9	M 08×30	5/16×1 1/4	0.16	FUS62	420	420
3/4	19	32.5	42.0	8.3	19	28	60	71.4	23.8	50.8	10.6	M 10×35	3/8×1 1/2	0.31	FUS63	420	420
1	25	38.8	48.4	9.0	24	33	70	81.0	27.8	57.2	13.3	M 12×45	-	0.49	FUS64	420	420
1	25	38.9	48.4	9.0	24	33	70	81.0	27.8	57.2	12.0	-	7/16×1 3/4	0.51	FUS64/12	420	420
1 1/4	32	44.5	54.8	9.8	27	38	78	95.3	31.8	66.6	15.0	M 14×50	-	0.77	FUS65	420	420
1 1/4	32	44.5	54.8	9.8	27	38	78	95.3	31.8	66.6	13.3	M 12×45	1/2×1 3/4	0.81	FUS65/12	420	420
1 1/2	38	51.6	64.3	12.1	30	43	96	112.8	36.5	79.3	16.7	M 16×55	5/8×2 1/4	1.31	FUS66	420	420
2	51	67.6	80.2	12.1	37	52	114	133.4	44.5	96.8	20.6	M 20×65	3/4×2 3/4	2.00	FUS68	420	420
2 1/2	64	90.0	108.9	20.5	45	45	150	180.0	58.7	123.8	25.0	M 24×75	-	3.95	FUS610	420	420
3	76	115.0	132.5	25.5	55	55	178	215.0	71.4	152.4	31.0	M 30×90	-	6.73	FUS612	420	420

1) Pressure shown = Item deliverable

$$\frac{\text{PN (bar)}}{10} = \text{PN (MPa)}$$

 *Please add the **suffixes** below according to the material/surface required.

Order code suffixes			
Material	Suffix surface and material	Example	Description
Steel, zinc plated, Cr(VI)-free	CF	FUS32CFX	only flange clamp
Stainless steel	SS	FUS32SSX	only flange clamp

FUSM SAE Full flanges with metric tapped holes

ISO 6162-1/-2

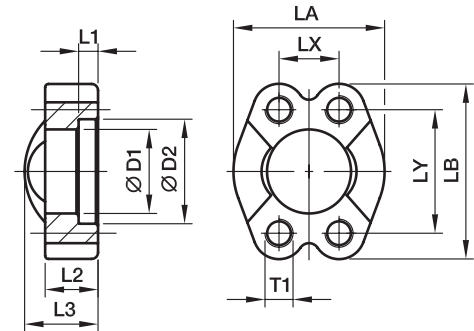

3000 PSI Series

Nom. flange size		D1	D2	L1	L2	L3	LA	LB	LX	LY	T1	Weight (steel) kg/piece	Order code*	PN (bar ¹⁾)	
SAE (in.)	ISO (DN)													CF	SS
1/2	13	24.3	31.0	6.2	13	20	46	54.0	17.5	38.1	M 8	0.13	FUSM32	345	345
3/4	19	32.1	38.9	6.2	14	22	52	65.0	22.3	47.6	M10	0.19	FUSM33	345	345
1	25	38.5	45.2	7.5	16	24	59	69.9	26.2	52.4	M10	0.23	FUSM34	345	345
1 1/4	32	43.7	51.6	7.5	16	22	73	79.4	30.2	58.7	M10	0.31	FUSM35/10	276	276
1 1/4	32	43.7	51.6	7.5	16	22	73	79.4	30.2	58.7	M12	0.30	FUSM35/12	276	276
1 1/2	38	50.8	61.1	7.5	16	25	83	93.8	35.7	69.9	M12	0.44	FUSM36	207	207
1 1/2	38	50.8	61.1	7.5	16	25	83	93.8	35.7	69.9	M14	0.47	FUSM36/14	207	207
2	51	62.8	72.3	9.0	16	26	97	101.6	42.9	77.8	M12	0.56	FUSM38/12	207	207
2	51	62.8	72.3	9.0	16	26	97	101.6	42.9	77.8	M14	0.54	FUSM38	207	207
2 1/2	64	74.9	84.9	9.0	19	38	109	114.3	50.8	88.9	M12	0.85	FUSM310	172	172
2 1/2	64	74.9	84.9	9.0	19	38	109	114.3	50.8	88.9	M14	0.73	FUSM310/14	172	172
3	76	90.9	102.4	9.0	22	41	131	135.0	61.9	106.4	M16	1.25	FUSM312	138	138
3 1/2	89	102.4	115.0	10.7	23	28	140	152.4	69.9	120.7	M16	1.66	FUSM314	34	34
4	102	115.1	127.8	10.7	25	35	150	162.0	77.8	130.2	M16	1.83	FUSM316	34	34
5	127	140.5	153.2	10.7	28	41	180	184.2	92.1	152.4	M16	2.50	FUSM320	34	34

6000 PSI Series

1/2	13	24.6	32.5	7.2	16	22	48	56.4	18.2	40.5	M 8	0.18	FUSM62	420	420
3/4	19	32.5	42.0	8.2	19	28	60	71.4	23.8	50.8	M10	0.34	FUSM63	420	420
1	25	38.9	48.4	9.0	24	33	70	81.0	27.8	57.2	M12	0.55	FUSM64	420	420
1 1/4	32	44.5	54.8	9.8	27	38	78	95.3	31.8	66.6	M14	0.87	FUSM65	420	420
1 1/4	32	44.5	54.8	9.8	27	38	78	95.3	31.8	66.6	M12	0.87	FUSM65/12	420	420
1 1/2	38	51.6	64.3	12.1	30	43	96	112.8	36.5	79.3	M16	1.33	FUSM66	420	420
2	51	67.6	80.2	12.1	37	52	114	133.4	44.5	96.8	M20	2.31	FUSM68	420	420
2 1/2	64	90.0	108.9	20.5	45	45	150	180.0	58.7	123.8	M24	4.02	FUSM610	420	420
3	76	115.0	132.5	25.5	55	55	178	215.0	71.4	152.4	M30	7.05	FUSM612	420	420

¹⁾Pressure shown = Item deliverable

$$\frac{PN \text{ (bar)}}{10} = PN \text{ (MPa)}$$

*Please add the **suffixes** below according to the material/surface required.

Order code suffixes			
Material	Suffix surface and material	Example only flange clamp with metr. threads	Description
Steel, zinc plated, Cr(VI)-free	CF	FUSM32CFM	only flange clamp
Stainless steel	SS	FUSM32SSM	only flange clamp

FHSF SAE Flange halves flat

ISO 6162-1/-2

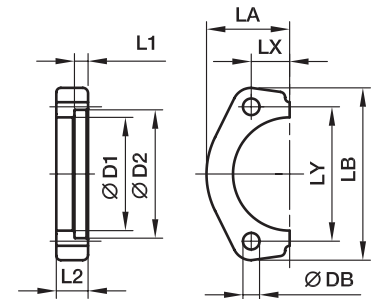

3000 PSI Series

Nom. flange size												Bolts		Weight (steel) kg/piece	Order code*	PN (bar) ¹⁾ CF
SAE (in.)	ISO (DN)	D1	D2	L1	L2	LA	LB	LX	LY	DB	(metr.)	(unc.)				
1/2	13	24.3	31.0	6.2	13	22.8	56	8.7	38.1	8.9	M 08x25	5/16x1 1/4	0.06	FHSF32	345	
3/4	19	32.1	38.9	6.2	14	25.9	65	11.1	47.6	10.6	M 10x30	3/8x1 1/4	0.07	FHSF33	345	
1	25	38.5	45.3	7.5	16	29.2	70	13.1	52.4	10.6	M 10x30	3/8x1 1/4	0.10	FHSF34	345	
1 1/4	32	43.7	51.6	7.5	16	36.6	79	15.1	58.7	10.6	M 10x35	-	0.16	FHSF35/10	276	
1 1/4	32	43.7	51.6	7.5	16	36.6	79	15.1	58.7	12.5	M 12x35	7/16x1 1/2	0.16	FHSF35/12	276	
1 1/2	38	50.8	61.1	7.5	16	41.1	94	17.9	69.9	13.5	M 12x35	1/2x1 1/2	0.21	FHSF36	207	
1 1/2	38	50.8	61.1	7.5	16	41.1	94	17.9	69.9	14.5	M 14x35	-	0.20	FHSF36/14	207	
2	51	62.8	72.3	9.0	16	48.2	104	21.4	77.8	13.5	M 12x35	1/2x1 1/2	0.26	FHSF38	207	
2	51	62.8	72.3	9.0	16	48.2	104	21.4	77.8	14.5	M 14x35	-	0.25	FHSF38/14	207	
2 1/2	64	74.9	84.9	9.0	19	53.0	114	25.4	88.9	13.5	M 12x40	1/2x1 3/4	0.38	FHSF310	172	
2 1/2	64	74.9	84.9	9.0	19	53.0	114	25.4	88.9	14.5	M 14x40	-	0.36	FHSF310/14	172	
3	76	90.9	102.4	9.0	22	64.3	135	31.0	106.4	16.7	M 16x45	5/8x1 3/4	0.57	FHSF312	138	

6000 PSI Series

1/2	13	24.6	32.5	7.2	16	23.6	56	9.1	40.5	8.9	M 08x30	5/16x1 1/4	0.08	FHSF62	420
3/4	19	32.5	42.0	8.3	20	30.0	71	11.9	50.8	10.6	M 10x35	3/8x1 1/2	0.14	FHSF63	420
1	25	38.8	48.4	9.0	25	34.8	81	13.9	57.2	13.3	M 12x45	-	0.23	FHSF64	420
1 1/4	32	44.5	54.8	9.8	27	38.6	95	15.9	66.6	15.0	M 14x50	-	0.34	FHSF65	420
1 1/4	32	44.5	54.8	9.8	27	38.6	95	15.9	66.6	13.3	M 12x50	1/2x1 3/4	0.34	FHSF65/12	420
1 1/2	38	51.6	64.3	12.1	30	47.5	113	18.3	79.3	16.7	M 16x55	5/8x2 1/4	0.59	FHSF66	420
2	51	67.6	80.2	12.1	37	56.9	133	22.2	96.8	20.6	M 20x65	3/4x2 3/4	0.93	FHSF68	420

1) Pressure shown = Item deliverable

$$\frac{\text{PN (bar)}}{10} = \text{PN (MPa)}$$

Material for steel: C60

 *Please add the **suffixes** below according to the material/surface required.

Order code suffixes			
Material	Suffix surface and material	Example	Description
Steel, zinc plated, Cr(VI)-free	CF	FHSF32CF	only flange half

FUSF SAE Full flanges flat

ISO 6162-1/-2

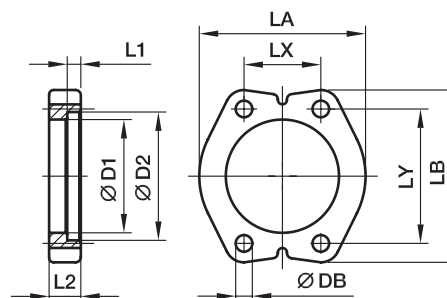
3000 PSI Series

Nom. flange size											Bolts		Weight (steel) kg/piece	Order code*	PN (bar) ¹⁾ CF
SAE (in.)	ISO (DN)	D1	D2	L1	L2	LA	LB	LX	LY	DB	(metr.)	(unc.)			
1/2	13	24.3	31.0	6.2	13	46	56	17.4	38.1	8.9	M 08×25	5/16×1 1/4	0.12	FUSF32	345
3/4	19	32.1	38.9	6.2	14	52	65	22.2	47.6	10.6	M 10×30	3/8×1 1/4	0.18	FUSF33	345
1	25	38.5	45.3	7.5	16	59	70	26.2	52.4	10.6	M 10×30	3/8×1 1/4	0.23	FUSF34	345
1 1/4	32	43.7	51.6	7.5	16	73	79	30.2	58.7	10.6	M 10×35	–	0.33	FUSF35/10	276
1 1/4	32	43.7	51.6	7.5	16	73	79	30.2	58.7	12.5	M 12×35	7/16×1 1/2	0.32	FUSF35/12	276
1 1/2	38	50.8	61.1	7.5	16	83	94	35.8	69.9	13.5	M 12×35	1/2×1 1/2	0.42	FUSF36	207
1 1/2	38	50.8	61.1	7.5	16	83	94	35.8	69.9	14.5	M 14×35	–	0.41	FUSF36/14	207
2	51	62.8	72.3	9.0	16	97	104	42.8	77.8	13.5	M 12×35	1/2×1 1/2	0.56	FUSF38/12	207
2	51	62.8	72.3	9.0	16	97	104	42.8	77.8	14.5	M 14×35	–	0.51	FUSF38	207
2 1/2	64	74.9	84.9	9.0	19	109	114	50.8	88.9	13.5	M 12×40	1/2×1 3/4	0.77	FUSF310	172
2 1/2	64	74.9	84.9	9.0	19	109	114	50.8	88.9	14.5	M 14×40	–	0.72	FUSF310/14	172
3	76	90.9	102.4	9.0	22	131	135	61.9	106.4	16.7	M 16×45	5/8×1 3/4	1.13	FUSF312	138

6000 PSI Series

1/2	13	24.6	32.5	7.2	16	48	56	18.2	40.5	8.9	M 08×30	5/16×1 1/4	0.17	FUSF62	420
3/4	19	32.5	42.0	8.3	20	60	71	23.8	50.8	10.6	M 10×35	3/8×1 1/2	0.32	FUSF63	420
1	25	38.8	48.4	9.0	25	70	81	27.8	57.2	13.3	M 12×45	–	0.56	FUSF64	420
1	25	38.8	48.4	9.0	25	70	81	27.8	57.2	12.0	M 12×45	7/16×1 3/4	0.56	FUSF64/12	420
1 1/4	32	44.5	54.8	9.8	27	78	95	31.8	66.6	15.0	M 14×50	–	0.76	FUSF65	420
1 1/4	32	44.5	54.8	9.8	27	78	95	31.8	66.6	13.3	M 12×50	1/2×1 3/4	0.76	FUSF65/12	420
1 1/2	38	51.6	64.3	12.1	30	95	113	36.5	79.3	16.7	M 16×55	5/8×2 1/4	1.30	FUSF66	420
2	51	67.6	80.2	12.1	37	114	133	44.5	96.8	20.6	M 20×65	3/4×2 3/4	1.88	FUSF68	420

¹⁾Pressure shown = Item deliverable

$$\frac{\text{PN (bar)}}{10} = \text{PN (MPa)}$$

Material for steel: C60

 *Please add the **suffixes** below according to the material/surface required.

Order code suffixes			
Material	Suffix surface and material	Example	Description
Steel, zinc plated, Cr(VI)-free	CF	FUSF32CF	only flange clamp

GFS SAE Straight flange adapter

SAE Flange / EO 24° cone end
(ISO 6162-1/-2)

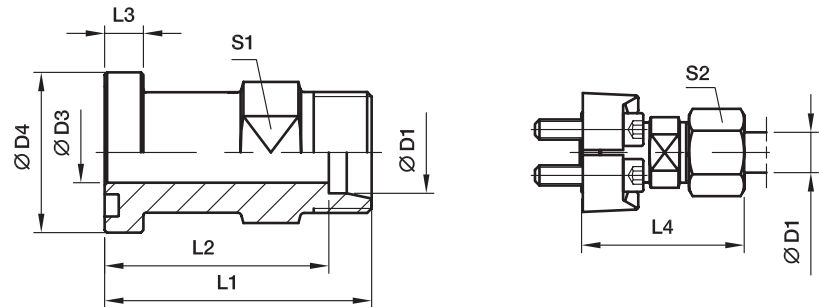

3000 PSI Series

Nom. flange size		D1 ²⁾									Bolts		Weight (steel) kg/piece	Order code*	PN (bar) ¹⁾	
SAE (in.)	ISO (DN)		D3	D4	L1	L2	L3	L4	S1	S2	(metr.)	(unc.)			CF	71
1/2	13	15L	12.0	30.2	48.0	41.0	6.7	56.0	24	27	M 08×25	5/16×1 1/4	0.13	GFS32/15L	315	315
1/2	13	16S	12.0	30.2	50.0	41.5	6.7	60.0	24	30	M 08×25	5/16×1 1/4	0.14	GFS32/16S	350	350
1/2	13	18L	14.0	30.2	50.0	42.5	6.7	61.0	19	32	M 08×25	5/16×1 1/4	0.12	GFS32/18L	315	315
3/4	19	16S	12.0	38.1	55.0	46.5	6.7	64.5	27	30	M 10×30	3/8×1 1/4	0.22	GFS33/16S	350	350
3/4	19	18L	17.0	38.1	53.0	45.5	6.7	62.0	30	32	M 10×30	3/8×1 1/4	0.22	GFS33/18L	315	315
3/4	19	22L	19.0	38.1	53.0	45.5	6.7	62.0	30	36	M 10×30	3/8×1 1/4	0.20	GFS33/22L	160	160
3/4	19	28L	19.0	38.1	55.0	41.0	6.7	64.0	32	41	M 10×30	3/8×1 1/4	0.23	GFS33/28L	160	160
3/4	19	20S	17.0	38.1	57.0	46.5	6.7	68.0	30	36	M 10×30	3/8×1 1/4	0.25	GFS33/20S	350	350
3/4	19	25S	17.0	38.1	57.0	45.0	6.7	69.0	30	46	M 10×30	3/8×1 1/4	0.27	GFS33/25S	350	350
1	25	20S	25.0	44.5	60.0	48.5	8.0	71.0	32	36	M 10×30	3/8×1 1/4	0.34	GFS34/20S	350	350
1	25	28L	24.0	44.5	54.0	46.5	8.0	63.0	36	41	M 10×30	3/8×1 1/4	0.28	GFS34/28L	160	160
1	25	25S	20.0	44.5	58.0	46.5	8.0	60.0	36	46	M 10×30	3/8×1 1/4	0.35	GFS34/25S	350	350
1	25	30S	24.0	44.5	63.0	49.5	8.0	76.0	36	50	M 10×30	3/8×1 1/4	0.36	GFS34/30S	250	250
1	25	42L	24.0	44.5	76.0	65.0	8.0	87.5	41	60	M 10×30	3/8×1 1/4	0.49	GFS34/42L	160	160
1 1/4	32	35L	32.0	50.8	58.0	47.5	8.0	69.0	41	50	M 10×35	-	0.36	GFS35/35L/10³⁾	160	160
1 1/4	32	25S	27.0	50.8	60.0	48.0	8.0	72.0	41	46	M 10×35	-	0.44	GFS35/25S/10³⁾	200	200
1 1/4	32	30S	28.5	50.8	62.0	48.5	8.0	75.0	41	50	M 10×35	-	0.44	GFS35/30S/10³⁾	200	200
1 1/4	32	38S	28.0	50.8	66.0	50.0	8.0	81.0	46	60	M 10×35	-	0.46	GFS35/38S/10³⁾	200	200
1 1/4	32	28L	23.0	50.8	60.0	52.5	8.0	67.0	36	41	M 12×40	7/16×1 1/2	0.41	GFS35/28L	160	160
1 1/4	32	35L	32.0	50.8	58.0	47.5	8.0	69.0	41	50	M 12×40	7/16×1 1/2	0.36	GFS35/35L	160	160
1 1/4	32	25S	27.0	50.8	60.0	48.0	8.0	72.0	41	46	M 12×40	7/16×1 1/2	0.44	GFS35/25S	200	200
1 1/4	32	30S	28.5	50.8	62.0	48.5	8.0	75.0	41	50	M 12×40	7/16×1 1/2	0.44	GFS35/30S	200	200
1 1/4	32	38S	28.0	50.8	66.0	50.0	8.0	81.0	46	60	M 12×40	7/16×1 1/2	0.46	GFS35/38S	200	200
1 1/2	38	35L	30.0	60.3	65.0	54.5	8.0	76.0	46	50	M 12×35	1/2×1 1/2	0.55	GFS36/35L	160	160
1 1/2	38	42L	36.0	60.3	64.0	53.0	8.0	76.0	46	60	M 12×35	1/2×1 1/2	0.49	GFS36/42L	160	160
1 1/2	38	38S	32.0	60.3	70.0	54.0	8.0	85.0	46	60	M 12×35	1/2×1 1/2	0.64	GFS36/38S	200	200

¹⁾ Pressure shown = Item deliverable

²⁾ L = light series; S = heavy series

$\frac{PN \text{ (bar)}}{10} = PN \text{ (MPa)}$

Delivery without nut and ring.

Information on ordering complete fittings or alternative sealing materials see page N12.

³⁾ Order code for the flange adapter assembled with FHS35/10CFX and M10×35 bolts.

See pages N16 and N19 for related flange halves depending on bolt sets.

Stainless steel parts may have dimensional deviations. Additional information on request.

*Please add the **suffixes** below according to the material/surface required.

Order code suffixes					
Material	Suffix surface and material	Example only flange adapter	Example incl. splitflanges, metr. bolts and O-ring	Example incl. splitflanges, UNC bolts and O-ring	Standard sealing material (no additional suffix needed)
Steel, zinc plated, Cr(VI)-free	CF	GFS32/16SCFX	GFS32/16SOMDCF	GFS32/16SOMDCFU	NBR
Stainless steel	71	GFS32/16S71X	GFS32/16SOMD71	-	VIT

SAE Flange adapters

GFS SAE Straight flange adapter

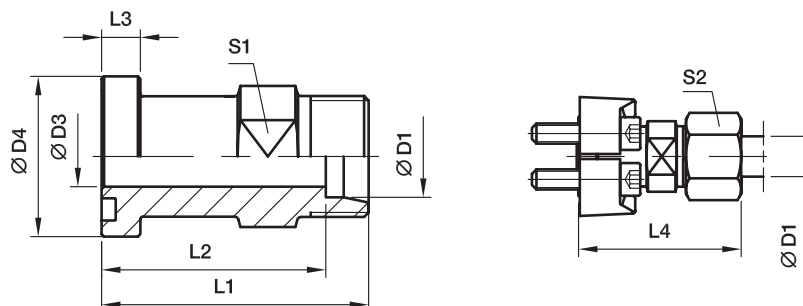
 SAE Flange / EO 24° cone end
 (ISO 6162-1/-2)

6000 PSI Series

Nom. flange size		D1 ²⁾									Bolts		Weight (steel) kg/piece	Order code*	PN (bar ¹⁾)	
SAE (in.)	ISO (DN)		D3	D4	L1	L2	L3	L4	S1	S2	(metr.)	(unc.)			CF	71
1/2	13	12S	8	31.8	50.0	42.5	7.7	57.5	19	24	M 08×30	5/16×1 1/4	0.14	GFS62/12S	420	420
1/2	13	14S	10	31.8	50.0	42.0	7.7	59.5	19	27	M 08×30	5/16×1 1/4	0.17	GFS62/14S	420	420
1/2	13	16S	12	31.8	50.0	41.5	7.7	49.5	19	30	M 08×30	5/16×1 1/4	0.15	GFS62/16S	420	420
3/4	19	16S	17	41.3	59.0	50.5	8.7	68.5	30	30	M 10×35	3/8×1 1/2	0.28	GFS63/16S	420	420
3/4	19	20S	17	41.3	61.0	50.5	8.7	72.0	30	36	M 10×35	3/8×1 1/2	0.27	GFS63/20S	420	400
3/4	19	25S	17	41.3	63.0	51.0	8.7	75.0	30	46	M 10×35	3/8×1 1/2	0.31	GFS63/25S	420	400
3/4	19	30S	18	41.3	76.0	62.0	8.7	89.0	30	50	M 10×35	3/8×1 1/2	0.42	GFS63/30S	420	400
3/4	19	38S	19	41.3	80.0	64.0	8.7	94.5	41	60	M 10×35	3/8×1 1/2	0.57	GFS63/38S	420	315
1	25	20S	16	47.6	75.0	64.5	9.5	88.0	36	36	M 12×45	7/16×1 3/4	0.49	GFS64/20S	420	400
1	25	25S	20	47.6	72.0	60.0	9.5	84.0	36	46	M 12×45	7/16×1 3/4	0.46	GFS64/25S	420	400
1	25	30S	24	47.6	74.0	62.0	9.5	87.0	36	50	M 12×45	7/16×1 3/4	0.43	GFS64/30S	420	400
1	25	38S	25	47.6	90.0	74.0	9.5	105.0	41	60	M 12×45	7/16×1 3/4	0.65	GFS64/38S	420	315
1 1/4	32	25S	20	54.0	80.0	68.0	10.2	92.0	41	46	M 14×50	-	0.68	GFS65/25S	420	400
1 1/4	32	25S	20	54.0	80.0	68.0	10.2	92.0	41	46	M 12×50	1/2×1 3/4	0.68	GFS65/25S/12³⁾	420	400
1 1/4	32	30S	30	54.0	79.0	65.5	10.2	92.0	41	50	M 12×50	1/2×1 3/4	0.58	GFS65/30S/12³⁾	420	400
1 1/4	32	38S	31	54.0	80.0	64.0	10.2	94.5	46	60	M 12×50	1/2×1 3/4	0.58	GFS65/38S/12³⁾	420	315
1 1/4	32	30S	30	54.0	79.0	65.5	10.2	92.0	41	50	M 14×50	-	0.58	GFS65/30S	420	400
1 1/4	32	38S	31	54.0	80.0	64.0	10.2	94.5	46	60	M 14×50	-	0.58	GFS65/38S	420	315
1 1/2	38	30S	30	63.5	90.0	76.5	12.5	103.0	46	50	M 16×55	5/8×2 1/4	1.00	GFS66/30S	420	400
1 1/2	38	38S	32	63.5	90.0	74.0	12.5	104.5	46	60	M 16×55	5/8×2 1/4	0.93	GFS66/38S	420	315

¹⁾ Pressure shown = Item deliverable

²⁾ S = heavy series

$$\frac{\text{PN (bar)}}{10} = \text{PN (MPa)}$$
Delivery without nut and ring.
Information on ordering complete fittings
or alternative sealing materials see page N12.
³⁾ Order code for the flange adapter assembled with FHS65/12CFX and M12×50 bolts.

See pages N16 and N19 for related flange halves depending on bolt sets.

Stainless steel parts may have dimensional deviations. Additional information on request.

 *Please add the **suffixes** below according to the material/surface required.

Order code suffixes					
Material	Suffix surface and material	Example only flange adapter	Example incl. splitflanges, metr. bolts and O-ring	Example incl. splitflanges, UNC bolts and O-ring	Standard sealing material (no additional suffix needed)
Steel, zinc plated, Cr(VI)-free	CF	GFS62/16SCFX	GFS62/16SOMDCF	GFS62/16SOMDCFU	NBR
Stainless steel	71	GFS62/16S71X	GFS62/16SOMD71	-	VIT

WFS SAE 90° Elbow flange adapter

SAE Flange / EO 24° cone end
(ISO 6162-1/-2)

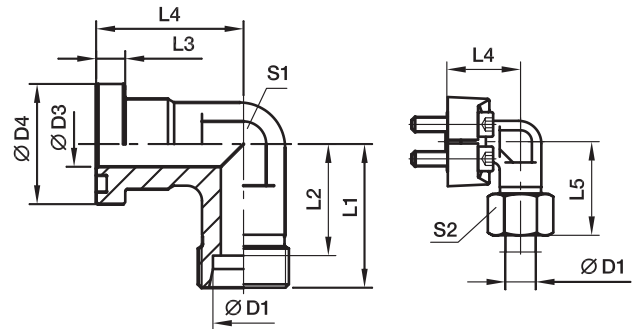

3000 PSI Series

Nom. flange size		D1 ²⁾											Bolts		Weight (steel) kg/piece	Order code*	PN (bar) ¹⁾	
SAE (in.)	ISO (DN)		D3	D4	L1	L2	L3	L4	L5	S1	S2	(metr.)	(unc.)	CF			71	
1/2	13	12S	12	30.2	50	42.5	6.7	44	58.5	22	24	M 08x25	5/16x1 1/4	0.24	WFS32/12S	210	210	
1/2	13	15L	12	30.2	36	29.0	6.7	36	44.0	24	27	M 08x25	5/16x1 1/4	0.16	WFS32/15L	315	315	
1/2	13	16S	12	30.2	38	29.5	6.7	36	48.0	24	30	M 08x25	5/16x1 1/4	0.17	WFS32/16S	350	350	
1/2	13	18L	12	30.2	50	42.5	6.7	44	59.0	22	32	M 08x25	5/16x1 1/4	0.20	WFS32/18L	315	315	
3/4	19	16S	19	38.1	64	55.5	6.7	53	73.5	27	30	M 10x30	3/8x1 1/4	0.36	WFS33/16S	350	350	
3/4	19	18L	19	38.1	39	31.5	6.7	42	48.0	30	32	M 10x30	3/8x1 1/4	0.30	WFS33/18L	315	315	
3/4	19	22L	19	38.1	41	33.5	6.7	42	50.0	30	36	M 10x30	3/8x1 1/4	0.28	WFS33/22L	160	160	
3/4	19	20S	17	38.1	43	32.5	6.7	42	54.0	30	36	M 10x30	3/8x1 1/4	0.33	WFS33/20S	350	350	
3/4	19	25S	17	38.1	45	33.0	6.7	42	57.0	30	46	M 10x30	3/8x1 1/4	0.32	WFS33/25S	350	350	
1	25	20S	16/23	44.5	65	54.5	8.0	60	77.0	34	36	M 10x30	3/8x1 1/4	0.55	WFS34/20S	350	350	
1	25	22L	18	44.5	65	57.5	8.0	60	74.0	34	36	M 10x30	3/8x1 1/4	0.53	WFS34/22L	160	160	
1	25	28L	25	44.5	44	36.5	8.0	45	53.0	36	41	M 10x30	3/8x1 1/4	0.41	WFS34/28L	160	160	
1	25	25S	20	44.5	48	36.5	8.0	45	57.0	36	46	M 10x30	3/8x1 1/4	0.52	WFS34/25S	350	350	
1	25	30S	24	44.5	50	36.5	8.0	45	63.0	36	50	M 10x30	3/8x1 1/4	0.48	WFS34/30S	250	250	
1 1/4	32	35L	32	50.8	57	46.5	8.0	50	68.0	41	50	M 10x35	-	0.53	WFS35/35L/10³⁾	160	160	
1 1/4	32	25S	27	50.8	55	43.0	8.0	60	67.0	41	46	M 10x35	-	0.72	WFS35/25S/10³⁾	200	200	
1 1/4	32	30S	28	50.8	57	43.5	8.0	50	70.0	41	50	M 10x35	-	0.67	WFS35/30S/10³⁾	200	200	
1 1/4	32	38S	28	50.8	59	43.0	8.0	50	74.0	46	60	M 10x35	-	0.71	WFS35/38S/10³⁾	200	200	
1 1/4	32	35L	32	50.8	57	46.5	8.0	50	68.0	41	50	M 12x40	7/16x1 1/2	0.53	WFS35/35L	160	160	
1 1/4	32	25S	27	50.8	55	43.0	8.0	50	67.0	41	46	M 12x40	7/16x1 1/2	0.72	WFS35/25S	200	200	
1 1/4	32	30S	28	50.8	57	43.5	8.0	50	70.0	41	50	M 12x40	7/16x1 1/2	0.67	WFS35/30S	200	200	
1 1/4	32	38S	28	50.8	59	43.0	8.0	50	74.0	41	60	M 12x40	7/16x1 1/2	0.71	WFS35/38S	200	200	
1 1/2	38	35L	30	60.3	78	67.5	8.0	66	83.0	50	50	M 12x35	1/2x1 1/2	1.36	WFS36/35L	160	160	
1 1/2	38	42L	36	60.3	58	47.0	8.0	55	70.0	50	60	M 12x35	1/2x1 1/2	0.73	WFS36/42L	160	160	
1 1/2	38	38S	36	60.3	64	48.0	8.0	55	79.0	50	60	M 12x35	1/2x1 1/2	0.95	WFS36/38S	200	200	

¹⁾ Pressure shown = Item deliverable

²⁾ L = light series; S = heavy series

$$\frac{\text{PN (bar)}}{10} = \text{PN (MPa)}$$

Delivery without nut and ring.

Information on ordering complete fittings or alternative sealing materials see page N12.

³⁾ Order code for the elbow flange adapter assembled with FHS35/10CFX and M10x35 bolts.

See pages N16 and N19 for related flange halves depending on bolt sets.

Stainless steel parts may have dimensional deviations. Additional information on request.

*Please add the suffixes below according to the material/surface required.

Order code suffixes					
Material	Suffix surface and material	Example only flange adapter	Example incl. splitflanges, metr. bolts and O-ring	Example incl. splitflanges, UNC bolts and O-ring	Standard sealing material (no additional suffix needed)
Steel, zinc plated, Cr(VI)-free	CF	WFS32/16SCFX	WFS32/16SOMDCF	WFS32/16SOMDCFU	NBR
Stainless steel	71	WFS32/16S71X	WFS32/16SOMD71	-	VIT

WFS SAE 90° Elbow flange adapter

SAE Flange / EO 24° cone end
(ISO 6162-1/-2)

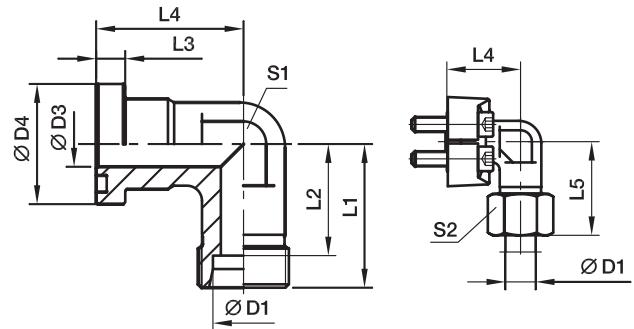

6000 PSI Series

Nom. flange size		D1 ²⁾											Bolts		Weight (steel) kg/piece	Order code*	PN (bar) ¹⁾	
SAE (in.)	ISO (DN)		D3	D4	L1	L2	L3	L4	L5	S1	S2	(metr.)	(unc.)	CF			71	
1/2	13	12S	12	31.8	50	42.5	7.7	44	58.5	22	24	M 08×30	5/16×1 1/4	0.22	WFS62/12S	420	420	
1/2	13	14S	12	31.8	50	42.0	7.7	44	59.5	22	27	M 08×30	5/16×1 1/4	0.27	WFS62/14S	420	420	
1/2	13	16S	12	31.8	38	29.5	7.7	39	48.0	24	30	M 08×30	5/16×1 1/4	0.19	WFS62/16S	420	420	
3/4	19	16S	17	41.3	45	36.5	8.7	48	55.0	32	30	M 10×35	3/8×1 1/2	0.42	WFS63/16S	420	420	
3/4	19	20S	17	41.3	46	35.5	8.7	48	57.0	32	36	M 10×35	3/8×1 1/2	0.42	WFS63/20S	420	400	
3/4	19	25S	17	41.3	48	36.0	8.7	48	60.0	32	46	M 10×35	3/8×1 1/2	0.46	WFS63/25S	420	400	
1	25	20S	16	47.6	65	54.5	9.5	62	75.0	34	36	M 12×45	7/16×1 3/4	0.60	WFS64/20S	420	400	
1	25	25S	20	47.6	53	41.0	9.5	60	65.0	41	46	M 12×45	7/16×1 3/4	0.74	WFS64/25S	420	400	
1	25	30S	25	47.6	55	41.5	9.5	60	68.0	41	50	M 12×45	7/16×1 3/4	0.64	WFS64/30S	420	400	
1 1/4	32	25S	25	54.0	72	60.0	10.2	70	84.0	42	46	M 12×50	1/2×1 3/4	1.06	WFS65/25S/12³⁾	420	400	
1 1/4	32	30S	30	54.0	58	44.5	10.2	68	71.0	46	50	M 12×50	1/2×1 3/4	0.88	WFS65/30S/12³⁾	420	400	
1 1/4	32	38S	30	54.0	72	56.0	10.2	70	87.0	46	60	M 12×50	1/2×1 3/4	0.93	WFS65/38S/12³⁾	420	315	
1 1/4	32	25S	20/28	54.0	72	60.0	10.3	70	84.0	42	46	M 14×50	-	1.06	WFS65/25S	420	400	
1 1/4	32	30S	30	54.0	58	44.5	10.2	68	71.0	46	50	M 14×50	-	0.88	WFS65/30S	420	400	
1 1/4	32	38S	30	54.0	72	56.0	10.2	70	87.0	46	60	M 14×50	-	0.93	WFS65/38S	420	315	
1 1/2	38	30S	25	63.5	76	63.5	12.5	77	90.0	50	50	M 16×55	5/8×2 1/4	1.75	WFS66/30S	420	400	
1 1/2	38	38S	32	63.5	84	68.0	12.5	80	99.0	50	60	M 16×55	5/8×2 1/4	1.46	WFS66/38S	420	315	

¹⁾Pressure shown = Item deliverable

²⁾S = heavy series

$$\frac{PN \text{ (bar)}}{10} = PN \text{ (MPa)}$$

Delivery without nut and ring.

Information on ordering complete fittings

or alternative sealing materials see page N12.

³⁾ Order code for the elbow flange adapter assembled with FHS65/12CFX and M12×50 bolts.

See pages N16 and N19 for related flange halves depending on bolt sets.

Stainless steel parts may have dimensional deviations. Additional information on request.

*Please add the suffixes below according to the material/surface required.

Order code suffixes					
Material	Suffix surface and material	Example only flange adapter	Example incl. splitflanges, metr. bolts and O-ring	Example incl. splitflanges, UNC bolts and O-ring	Standard sealing material (no additional suffix needed)
Steel, zinc plated, Cr(VI)-free	CF	WFS62/16SCFX	WFS62/16SOMDCF	WFS62/16SOMDCFU	NBR
Stainless steel	71	WFS62/16S71X	WFS62/16SOMD71	-	VIT

GFS-G SAE Straight flange adapter

SAE Flange / BSP 60° cone end
(ISO 6162-1/-2) (ISO 8434-6)

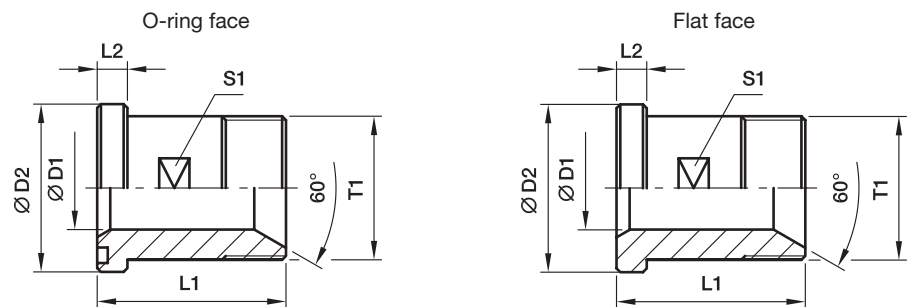

3000 PSI Series

Nom. flange size		T1	D1	D2	L1	L2	S1	Weight (steel) kg/piece	O-ring face Order code*	Flat face Order code*	PN (bar) ¹⁾	
SAE (in.)	ISO (DN)										CF	SS
1/2	13	G 1/2	12	30.2	50	6.7	19	0.11	GFS32/12G	GFSG32/12G	345	345
1/2	13	G 3/8	10	30.2	50	6.7	19	0.12	GFS32/38G	GFSG32/38G	345	345
3/4	19	G 3/4	17	38.1	55	6.7	27	0.18	GFS33/34G	GFSG33/34G	345	345
3/4	19	G 1/2	12	38.1	55	6.7	27	0.21	GFS33/12G	GFSG33/12G	345	345
1	25	G 1	22	44.4	60	8.0	32	0.28	GFS34/1G	GFSG34/1G	345	345
1	25	G 3/4	17	44.4	60	8.0	32	0.31	GFS34/34G	GFSG34/34G	345	345
1 1/4	32	G 1 1/4	27	50.8	65	8.0	41	0.41	GFS35/114G	GFSG35/114G	276	276
1 1/4	32	G 1	22	50.8	65	8.0	41	0.44	GFS35/1G	GFSG35/1G	276	276
1 1/2	38	G 1 1/2	32	60.3	70	8.0	46	0.58	GFS36/112G	GFSG36/112G	207	207
1 1/2	38	G 1 1/4	27	60.3	70	8.0	46	0.64	GFS36/114G	GFSG36/114G	207	207
2	51	G 2	40	71.4	75	9.5	55	0.89	GFS38/2G	GFSG38/2G	207	207
2	51	G 1 1/2	32	71.4	75	9.5	55	1.01	GFS38/112G	GFSG38/112G	207	207

6000 PSI Series

1/2	13	G 1/2	12	31.8	50	7.7	19	0.12	GFS62/12G	GFSG62/12G	420	420
1/2	13	G 3/8	10	31.8	50	7.7	19	0.13	GFS62/38G	GFSG62/38G	420	420
3/4	19	G 3/4	17	41.3	60	8.7	26	0.24	GFS63/34G	GFSG63/34G	420	420
3/4	19	G 1/2	12	41.3	60	8.7	26	0.22	GFS63/12G	GFSG63/12G	420	420
1	25	G 1	22	47.6	70	9.5	32	0.35	GFS64/1G	GFSG64/1G	420	420
1	25	G 3/4	17	47.6	70	9.5	32	0.40	GFS64/34G	GFSG64/34G	420	420
1 1/4	32	G 1 1/4	27	54.0	75	10.3	36	0.50	GFS65/114G	GFSG65/114G	420	420
1 1/4	32	G 1 1/4	27	54.0	75	10.3	36	0.50	GFS65/114G/12³⁾	GFSG65/114G/12³⁾	420	420
1 1/4	32	G 1	22	54.0	75	10.3	36	0.54	GFS65/1G	GFSG65/1G	420	420
1 1/4	32	G 1	22	54.0	75	10.3	36	0.54	GFS65/1G/12³⁾	GFSG65/1G/12³⁾	420	420
1 1/2	38	G 1 1/2	32	63.5	80	12.5	46	0.73	GFS66/112G	GFSG66/112G	420	420
1 1/2	38	G 1 1/4	27	63.5	80	12.5	46	0.80	GFS66/114G	GFSG66/114G	420	420
2	51	G 2	40	79.4	90	12.5	55	1.34	GFS68/2G	GFSG68/2G	420	420
2	51	G 1 1/2	32	79.4	90	12.5	55	1.54	GFS68/112G	GFSG68/112G	420	420

¹⁾ Pressure shown = Item deliverable

PN (bar) = PN (MPa)
10

³⁾ Order code for the straight flange adapter assembled with FHS65/12CFX and M12×45 bolts.

See pages N16 and N19 for related flange halves depending on bolt sets.

Stainless steel parts may have dimensional deviations. Additional information on request.

*Please add the **suffixes** below according to the material/surface required.

Order code suffixes					
Material	Suffix surface and material	Example only flange adapter	Example incl. splitflanges, metr. bolts and O-ring	Example incl. splitflanges, UNC bolts and O-ring	Standard sealing material (no additional suffix needed)
Steel, zinc plated, Cr(VI)-free	CF	GFS32/12GCF	GFS32/12GCFM	GFS32/12GCFU	NBR
Stainless steel	SS	GFS32/12GSS	GFS32/12GSSM	-	VIT

SAE Flange adapters

WFS-G SAE 90° Elbow flange adapter

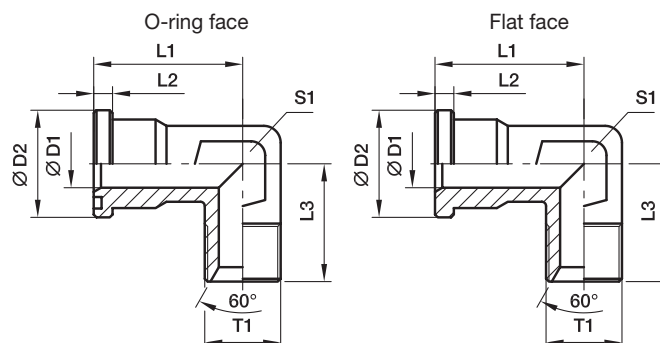
 SAE Flange / BSPP 60° cone end
 (ISO 6162-1/-2) (ISO 8434-6)

3000 PSI Series

Nom. flange size		T1	D1	D2	L1	L2	L3	S1	Weight (steel) kg/piece	O-ring face Order code*	Flat face Order code*	PN (bar) ¹⁾	
SAE (in.)	ISO (DN)											CF	SS
1/2	13	G 1/2	12	30.2	44	6.7	50	22	0.19	WFS32/12G	WFSG32/12G	345	345
1/2	13	G 3/8	10	30.2	44	6.7	50	22	0.20	WFS32/38G	WFSG32/38G	345	345
3/4	19	G 1/2	12	38.1	53	6.7	64	27	0.42	WFS33/12G	WFSG33/12G	345	345
3/4	19	G 3/4	17	38.1	53	6.7	64	27	0.35	WFS33/34G	WFSG33/34G	345	345
3/4	19	G 1	19	38.1	53	6.7	64	27	0.36	WFS33/1G	WFSG33/1G	345	345
1	25	G 3/4	17	44.4	60	8.0	65	34	0.71	WFS34/34G	WFSG34/34G	345	345
1	25	G 1	22	44.4	60	8.0	65	34	0.52	WFS34/1G	WFSG34/1G	345	345
1	25	G 1 1/4	25	44.4	60	8.0	65	34	0.62	WFS34/114G	WFSG34/114G	345	345
1 1/4	32	G 1	22	50.8	55	8.0	64	42	0.84	WFS35/1G	WFSG35/1G	276	276
1 1/4	32	G 1 1/4	28	50.8	55	8.0	64	42	0.76	WFS35/114G	WFSG35/114G	276	276
1 1/2	38	G 1 1/4	28	60.3	66	8.0	78	50	1.49	WFS36/114G	WFSG36/114G	207	207
1 1/2	38	G 1 1/2	34	60.3	66	8.0	78	50	1.23	WFS36/112G	WFSG36/112G	207	207

6000 PSI Series

1/2	13	G 1/2	12	31.8	44	7.7	50	22	0.22	WFS62/12G	WFSG62/12G	420	420
1/2	13	G 3/8	10	31.8	44	7.7	50	22	0.37	WFS62/34G	WFSG62/34G	420	420
3/4	19	G 1/2	14	41.3	53	8.7	64	27	0.88	WFS63/12G	WFSG63/12G	420	420
3/4	19	G 3/4	17	41.3	53	8.7	64	27	0.37	WFS63/34G	WFSG63/34G	420	420
3/4	19	G 1	19	41.3	53	8.7	64	27	0.41	WFS63/1G	WFSG63/1G	420	420
1	25	G 3/4	17	47.6	60	9.5	62	34	0.69	WFS64/34G	WFSG64/34G	420	420
1	25	G 1	22	47.6	60	9.5	62	34	0.59	WFS64/1G	WFSG64/1G	420	420
1	25	G 1 1/4	25	47.6	60	9.5	62	34	1.70	WFS64/114G	WFSG64/114G	420	420
1 1/4	32	G 1	22	54.0	70	10.3	72	42	1.17	WFS65/1G	WFSG65/1G	420	420
1 1/4	32	G 1	22	54.0	70	10.3	72	42	1.17	WFS65/1G/12³⁾	WFSG65/1G/12³⁾	420	420
1 1/4	32	G 1 1/4	27	54.0	70	10.3	72	42	0.99	WFS65/114G	WFSG65/114G	420	420
1 1/4	32	G 1 1/4	27	54.0	70	10.3	72	42	0.99	WFS65/114G/12³⁾	WFSG65/114G/12³⁾	420	420
1 1/2	38	G 1 1/4	27	63.5	80	12.5	84	50	1.70	WFS66/114G	WFSG66/114G	420	420
1 1/2	38	G 1 1/2	32	63.5	80	12.5	84	50	1.47	WFS66/112G	WFSG66/112G	420	420

¹⁾ Pressure shown = Item deliverable

$$\frac{\text{PN (bar)}}{10} = \text{PN (MPa)}$$
³⁾ Order code for the elbow flange adapter assembled with FHS65/12CFX and M12×45 bolts.

See pages N16 and N19 for related flange halves depending on bolt sets.

Stainless steel parts may have dimensional deviations. Additional information on request.

 *Please add the **suffixes** below according to the material/surface required.

Order code suffixes					
Material	Suffix surface and material	Example only flange adapter	Example incl. splitflanges, metr. bolts and O-ring	Example incl. splitflanges, UNC bolts and O-ring	Standard sealing material (no additional suffix needed)
Steel, zinc plated, Cr(VI)-free	CF	WFS32/12GCF	WFS32/12GCFM	WFS32/12GCFU	NBR
Stainless steel	SS	WFS32/12GSS	WFS32/12GSSM	–	VIT

GFS-N SAE Flange adapters straight

SAE Flange / Male NPT thread
(ISO 6162-1/-2) (SAE J476)

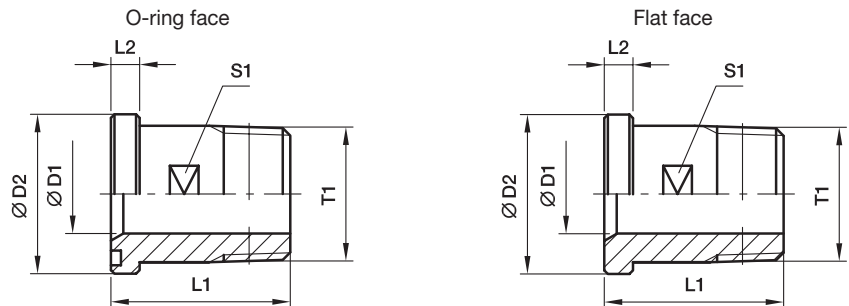

3000 PSI Series

Nom. flange size		T1	D1	D2	L1	L2	S1	Weight (steel) kg/piece	O-ring face	Flat face	PN (bar) ¹⁾	
SAE (in.)	ISO (DN)								Order code*	Order code*	CF	SS
1/2	13	1/2 NPT	12	30.2	50	6.7	19	0.12	GFS32/12N	GFSG32/12N	345	345
1/2	13	3/8 NPT	10	30.2	50	6.7	19	0.12	GFS32/38N	GFSG32/38N	345	345
3/4	19	3/4 NPT	17	38.1	55	6.7	27	0.18	GFS33/34N	GFSG33/34N	345	345
3/4	19	1/2 NPT	12	38.1	55	6.7	27	0.16	GFS33/12N	GFSG33/12N	345	345
1	25	1 NPT	22	44.4	60	8.0	32	0.29	GFS34/1N	GFSG34/1N	345	345
1	25	3/4 NPT	17	44.4	60	8.0	32	0.32	GFS34/34N	GFSG34/34N	345	345
1 1/4	32	1 1/4 NPT	27	50.8	65	8.0	41	0.42	GFS35/114N	GFSG35/114N	276	276
1 1/4	32	1 NPT	22	50.8	65	8.0	41	0.44	GFS35/1N	GFSG35/1N	276	276
1 1/2	38	1 1/2 NPT	32	60.3	70	8.0	46	0.62	GFS36/112N	GFSG36/112N	207	207
1 1/2	38	1 1/4 NPT	27	60.3	70	8.0	46	0.66	GFS36/114N	GFSG36/114N	207	207
2	51	2 NPT	40	71.4	75	9.5	55	0.99	GFS38/2N	GFSG38/2N	207	207
2	51	1 1/2 NPT	32	71.4	75	9.5	55	1.05	GFS38/112N	GFSG38/112N	207	207

6000 PSI Series

1/2	13	1/2 NPT	12	31.8	50	7.7	19	0.09	GFS62/12N	GFSG62/12N	420	420
1/2	13	3/8 NPT	10	31.8	50	7.7	19	0.13	GFS62/38N	GFSG62/38N	420	420
3/4	19	3/4 NPT	17	41.3	60	8.7	26	0.24	GFS63/34N	GFSG63/34N	420	420
3/4	19	1/2 NPT	12	41.3	60	8.7	26	0.25	GFS63/12N	GFSG63/12N	420	420
1	25	1 NPT	22	47.6	70	9.5	32	0.41	GFS64/1N	GFSG64/1N	420	420
1	25	3/4 NPT	17	47.6	70	9.5	32	0.43	GFS64/34N	GFSG64/34N	420	420
1 1/4	32	1 1/4 NPT	27	54.0	75	10.3	36	0.57	GFS65/114N	GFSG65/114N	420	420
1 1/4	32	1 1/4 NPT	27	54.0	75	10.3	36	0.57	GFS65/114N/12 ³⁾	GFSG65/114N/12 ³⁾	420	420
1 1/4	32	1 NPT	22	54.0	75	10.3	36	0.57	GFS65/1N	GFSG65/1N	420	420
1 1/4	32	1 NPT	22	54.0	75	10.3	36	0.57	GFS65/1N/12 ³⁾	GFSG65/1N/12 ³⁾	420	420
1 1/2	38	1 1/2 NPT	32	63.5	80	12.5	46	0.77	GFS66/112N	GFSG66/112N	420	420
1 1/2	38	1 1/4 NPT	27	63.5	80	12.5	46	0.81	GFS66/114N	GFSG66/114N	420	420
2	51	2 NPT	40	79.4	90	12.5	55	1.41	GFS68/2N	GFSG68/2N	420	420
2	51	1 1/2 NPT	32	79.4	90	12.5	55	1.57	GFS68/112N	GFSG68/112N	420	420

¹⁾ Pressure shown = Item deliverable

$$\frac{\text{PN (bar)}}{10} = \text{PN (MPa)}$$

³⁾ Order code for the straight flange adapter assembled with FHS65/12CFX and M12x45 bolts.

See pages N16 and N19 for related flange halves depending on bolt sets.

Stainless steel parts may have dimensional deviations. Additional information on request.

*Please add the **suffixes** below according to the material/surface required.

Order code suffixes					
Material	Suffix surface and material	Example only flange adapter	Example incl. splitflanges, metr. bolts and O-ring	Example incl. splitflanges, UNC bolts and O-ring	Standard sealing material (no additional suffix needed)
Steel, zinc plated, Cr(VI)-free	CF	GFS32/12NCF	GFS32/12NCFM	GFS32/12NCFU	NBR
Stainless steel	SS	GFS32/12NSS	GFS32/12NSSM	-	VIT

L(O)HQ SAE Straight flange adapter

SAE Flange / O-Lok® ORFS end
(ISO 6162-1/-2)

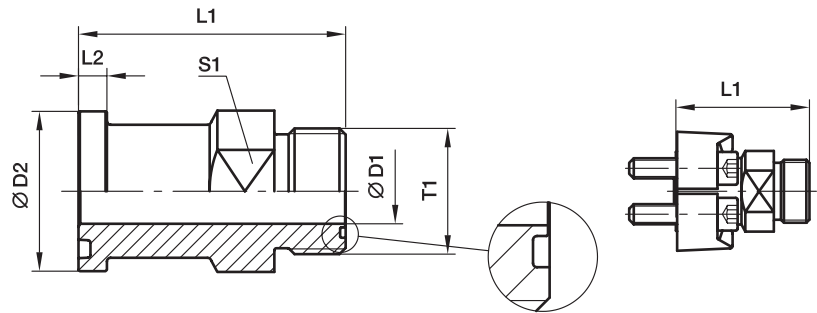

3000 PSI Series

Nom. flange size		Tube		T1	D1	D2	L1	L2	S1	Weight (steel) kg/piece	O-ring face without ORFS O-ring	O-ring face include ORFS O-ring	PN (bar) ¹⁾ S
SAE (in.)	ISO (DN)	(metr.)	(in.)								Order code*	Order code*	
3/4	19	18, 20	3/4	1 3/16-12UN	15.5	38.1	70.9	6.7	35.0	0.21	12LHQ1	12LOHQ1	350
1	25	22, 25	7/8, 1	1 7/16-12UN	20.6	44.5	71.4	8.0	41.0	0.30	16LHQ1	16LOHQ1	350
1 1/4	32	28, 30, 32	1 1/4	1 11/16-12UN	26.0	50.8	81.5	8.0	47.5	0.31	20LHQ1	20LOHQ1	280
1 1/2	38	35, 38	1 1/2	2-12UN	32.0	60.3	83.6	8.0	54.0	0.56	24LHQ1	24LOHQ1	210

6000 PSI Series

3/4	19	18, 20	3/4	1 3/16-12UN	15.5	41.3	76.7	8.8	35.0	0.21	12LHQ2	12LOHQ2	420
1	25	18, 20	3/4	1 3/16-12UN	15.5	47.6	84.8	9.5	35.0	0.26	12-16LHQ2	12-16LOHQ2	420
1	25	22, 27	3/4, 7/8	1 7/16-12UN	20.6	47.6	85.3	9.5	41.0	0.30	16LHQ2	16LOHQ2	420
1 1/4	32	28, 30, 32	1 1/4	1 11/16-12UN	26.0	54.0	88.4	10.3	47.5	0.31	20LHQ2	20LOHQ2	345
1 1/2	38	35, 38	1 1/2	2-12UN	32.0	63.5	105.2	12.6	54.0	0.56	24LHQ2	24LOHQ2	310

¹⁾Pressure shown = Item deliverable

$$\frac{PN \text{ (bar)}}{10} = PN \text{ (MPa)}$$

See pages N16 and N19 for related flange halves depending on bolt sets.

Stainless steel parts may have dimensional deviations. Additional information on request.

*Please add the **suffixes** below according to the material/surface required.

Order code suffixes				
Material	Suffix surface and material	Example only flange adapter without ORFS O-ring	Example only flange adapter incl. ORFS O-ring	Standard sealing material (no additional suffix needed)
Steel, oiled	S	12LHQ1-S	12LOHQ1-S	NBR

L(O)EMQ SAE 90° Elbow flange adapter

SAE Flange / O-Lok® ORFS end
(ISO 6162-1/-2)

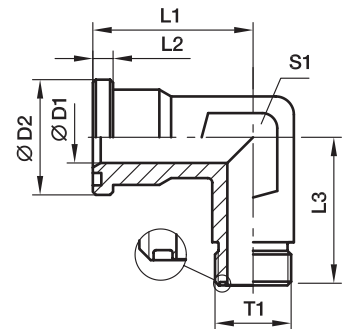

3000 PSI Series

Nom. flange size		Tube		T1	D1	D2	L1	L2	L3	S1	Weight (steel) kg/piece	O-ring face without ORFS O-ring	O-ring face include ORFS O-ring	PN (bar) ¹⁾	
SAE (in.)	ISO (DN)	(metr.)	(in.)									Order code*	Order code*	CF	SS
1/2	13	8, 10	3/8	11/16-16UN	6	30.2	44	6.7	50	22	0.40	6-8LEMQ1	6-8LOEMQ1	350	350
1/2	13	12	1/2	13/16-16UN	9	30.2	44	6.7	50	22	0.36	8LEMQ1	8LOEMQ1	350	350
1/2	13	14, 15, 16	5/8	1-14UN	12	30.2	44	6.7	50	22	0.32	10-8LEMQ1	10-8LOEMQ1	350	350
3/4	19	14, 15, 16	5/8	1-14UN	12	38.1	53	6.7	64	27	0.47	10-12LEMQ1	10-12LOEMQ1	350	350
3/4	19	18, 20	3/4	1 3/16-12UN	15	38.1	53	6.7	64	27	0.44	12LEMQ1	12LOEMQ1	350	350
1	25	18, 20	3/4	1 3/16-12UN	15	44.4	60	8.0	65	34	0.52	12-16LEMQ1	12-16LOEMQ1	350	350
1	25	22, 25	7/8, 1	1 7/16-12UN	20	44.4	60	8.0	65	34	0.50	16LEMQ1	16LOEMQ1	350	350
1 1/4	32	22, 25	7/8, 1	1 7/16-12UN	20	50.8	55	8.0	64	42	0.48	16-20LEMQ1	16-20LOEMQ1	278	278
1 1/4	32	28, 30, 32	1 1/4	1 11/16-12UN	26	50.8	55	8.0	64	42	0.56	20LEMQ1	20LOEMQ1	278	278
1 1/2	38	28, 30, 32	1 1/4	1 11/16-12UN	26	60.3	66	8.0	78	50	0.73	20-24LEMQ1	20-24LOEMQ1	207	207
1 1/2	38	35, 38	1 1/2	2-12UN	32	60.3	66	8.0	78	50	0.69	24LEMQ1	24LOEMQ1	207	207

6000 PSI Series

1/2	13	8, 10	3/8	11/16-16UN	6	31.8	44	7.7	50	22	0.40	6-8LEMQ2	6-8LOEMQ2	420	420
1/2	13	12	1/2	13/16-16UN	9	31.8	44	7.7	50	22	0.36	8LEMQ2	8LOEMQ2	420	420
1/2	13	14, 15, 16	5/8	1-14UN	12	31.8	44	7.7	50	22	0.32	10-8LEMQ2	10-8LOEMQ2	420	420
3/4	19	14, 15, 16	5/8	1-14UN	12	41.3	53	8.7	64	27	0.47	10-12LEMQ2	10-12LOEMQ2	420	420
3/4	19	18, 20	3/4	1 3/16-12UN	15	41.3	53	8.7	64	27	0.44	12LEMQ2	12LOEMQ2	420	420
1	25	18, 20	3/4	1 3/16-12UN	15	47.6	60	9.5	62	34	0.52	12-16LEMQ2	12-16LOEMQ2	420	420
1	25	22, 25	7/8, 1	1 7/16-12UN	20	47.6	60	9.5	62	34	0.50	16LEMQ2	16LOEMQ2	420	420
1 1/4	32	22, 25	7/8, 1	1 7/16-12UN	20	54.0	70	10.3	72	42	0.48	16-20LEMQ2	16-20LOEMQ2	420	420
1 1/4	32	28, 30, 32	1 1/4	1 11/16-12UN	26	54.0	70	10.3	72	42	0.56	20LEMQ2	20LOEMQ2	345	345
1 1/2	38	28, 30, 32	1 1/4	1 11/16-12UN	26	63.5	80	12.5	84	50	0.73	20-24LEMQ2	20-24LOEMQ2	345	345
1 1/2	38	35, 38	1 1/2	2-12UN	32	63.5	80	12.5	84	50	0.69	24LEMQ2	24LOEMQ2	310	310

1) Pressure shown = Item deliverable

$$\frac{\text{PN (bar)}}{10} = \text{PN (MPa)}$$

See pages N16 and N19 for related flange halves depending on bolt sets.

Stainless steel parts may have dimensional deviations. Additional information on request.

*Please add the **suffixes** below according to the material/surface required.

Order code suffixes				
Material	Suffix surface and material	Example only flange adapter without ORFS O-ring	Example only flange adapter incl. ORFS O-ring	Standard sealing material (no additional suffix needed)
Steel, zinc plated, Cr(VI)-free	CF	12LEMQ1CF	12LOEMQ1CF	NBR
Stainless steel	SS	12LEMQ1SS	12LOEMQ1SS	VIT

SAE Flange adapters

L(O)VQ SAE 45° Elbow flange adapter

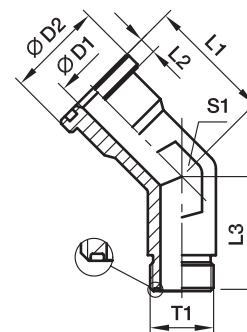
 SAE Flange / O-Lok® ORFS end
 (ISO 6162-1/-2)

3000 PSI Series

Nom. flange size		Tube		T1	D1	D2	L1	L2	L3	S1	Weight (steel) kg/piece	O-ring face without ORFS	O-ring face include ORFS	PN (bar) ¹⁾ S
SAE (in.)	ISO (DN)	(metr.)	(in.)									Order code*	Order code*	
3/4	19	18, 20	3/4	1 3/16-12UN	15.5	38.1	40.0	6.7	30.5	36.0	0.29	12LVQ1	12LOVQ1	350
1	25	22, 25	7/8, 1	1 7/16-12UN	20.5	44.5	47.0	8.0	32.0	41.0	0.39	16LVQ1	16LOVQ1	350
1 1/4	32	28, 30, 32	1 1/4	1 11/16-12UN	26.0	50.8	61.0	8.0	32.8	47.5	0.45	20LVQ1	20LOVQ1	280
1 1/2	38	35, 38	1 1/2	2-12UN	32.0	60.3	73.7	8.0	36.8	63.5	0.57	24LVQ1	24LOVQ1	210

6000 PSI Series

3/4	19	18, 20	3/4	1 3/16-12UN	15.5	41.3	46.5	8.8	30.5	36.0	0.29	12LVQ2	12LOVQ2	420
1	25	22, 25	7/8, 1	1 7/16-12UN	20.5	47.6	52.6	9.5	32.0	41.0	0.39	16LVQ2	16LOVQ2	420
1 1/4	32	28, 30, 32	1 1/4	1 11/16-12UN	26.0	54.0	61.0	10.3	32.8	47.5	0.45	20LVQ2	20LOVQ2	345
1 1/2	38	35, 38	1 1/2	2-12UN	32.0	63.5	73.7	12.6	36.8	63.5	0.57	24LVQ2	24LOVQ2	310

¹⁾Pressure shown = Item deliverable

$$\frac{PN(\text{bar})}{10} = PN(\text{MPa})$$

Stainless steel on request.

See pages N16 and N19 for related flange halves depending on bolt sets.

Stainless steel parts may have dimensional deviations. Additional information on request.

 *Please add the **suffixes** below according to the material/surface required.

Order code suffixes				
Material	Suffix surface and material	Example only flange adapter without ORFS O-ring	Example only flange adapter incl. ORFS O-ring	Standard sealing material (no additional suffix needed)
Steel, oiled	S	12LVQ1-S	12LOVQ1-S	NBR

XHQ SAE Straight flange adapter

SAE Flange / Triple-Lok® 37° flare end
(ISO 6162-1/-2)

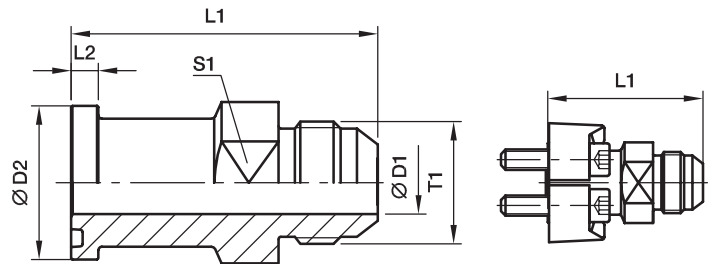

3000 PSI Series

Nom. flange size		Tube		T1	D1	D2	L1	L2	S1	Weight (steel) kg/piece	Order code*	PN (bar) ¹⁾
SAE (in.)	ISO (DN)	(metr.)	(in.)									S
3/4	19	18, 20	3/4	1 1/16-12UN	15.5	38.1	70.4	6.7	35.0	0.21	12XHQ1	350
1	25	22, 25	7/8, 1	1 5/16-12UN	21.5	44.5	73.9	8.0	41.0	0.30	16XHQ1	350
1 1/4	32	28, 30, 32	1 1/4	1 5/8-12UN	27.5	50.8	85.3	8.0	47.5	0.31	20XHQ1	275
1 1/2	38	35, 38	1 1/2	1 7/8-12UN	33.5	60.3	90.7	8.0	54.0	0.56	24XHQ1	210
2	51	50	2	2 1/2-12UN	45.0	71.4	102.6	9.5	66.5	1.10	32XHQ1	138

6000 PSI Series

3/4	19	18, 20	3/4	1 1/16-12UN	15.5	41.3	78.2	8.8	35.0	0.21	12XHQ2	350
1	25	22, 25	7/8, 1	1 5/16-12UN	21.5	47.6	87.1	9.5	41.0	0.30	16XHQ2	350
1 1/4	32	28, 30, 32	1 1/4	1 5/8-12UN	27.5	54.0	91.4	10.3	47.5	0.31	20XHQ2	275
1 1/2	38	35, 38	1 1/2	1 7/8-12UN	33.5	63.5	110.2	12.6	54.0	0.56	24XHQ2	210

¹⁾Pressure shown = Item deliverable

$$\frac{PN \text{ (bar)}}{10} = PN \text{ (MPa)}$$

Stainless steel on request.

See pages N16 and N19 for related flange halves depending on bolt sets.

*Please add the **suffixes** below according to the material/surface required.

Order code suffixes			
Material	Suffix surface and material	Example only flange adapter	Standard sealing material (no additional suffix needed)
Steel, oiled	S	12XHQ1-S	NBR

SAE Flange adapters

XEMQ SAE 90° Elbow flange adapter

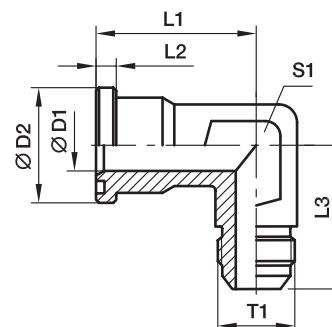
 SAE Flange / Triple-Lok® 37° flare end
 (ISO 6162-1/-2)

3000 PSI Series

Nom. flange size		Tube		T1	D1	D2	L1	L2	L3	S1	Weight (steel) kg/piece	Order code*	PN (bar) ¹⁾	
SAE (in.)	ISO (DN)	(metr.)	(in.)										S	SS
1/2	13	12	1/2	3/4-16UNF	10	30.2	44	6.7	50	22	0.20	8XEMQ1	350	350
1/2	13	14, 15, 16	5/8	7/8-14UNF	12	30.2	44	6.7	50	22	0.20	10-8XEMQ1	350	350
3/4	19	14, 15, 16	5/8	7/8-14UNF	19	38.1	53	6.7	64	27	0.29	10-12XEMQ1	350	350
3/4	19	18, 20	3/4	1 1/16-12UN	19	38.1	53	6.7	64	27	0.29	12XEMQ1	350	350
3/4	19	25	1	1 5/16-12UN	19	38.1	53	6.7	64	27	0.29	16-12XEMQ1	350	350
1	25	18, 20	3/4	1 1/16-12UN	22	44.4	60	8.0	65	34	0.39	12-16XEMQ1	350	350
1	25	25	1	1 5/16-12UN	22	44.4	60	8.0	65	34	0.39	16XEMQ1	350	350
1	25	30, 32	1 1/4	1 5/8-12UN	22	44.4	60	8.0	65	34	0.39	20-16XEMQ1	275	275
1 1/4	32	25	1	1 5/16-12UN	28	50.8	55	8.0	64	42	0.45	16-20XEMQ1	275	275
1 1/4	32	30, 32	1 1/4	1 5/8-12UN	28	50.8	55	8.0	64	42	0.45	20XEMQ1	275	275
1 1/2	38	30, 32	1 1/4	1 5/8-12UN	38	60.3	66	8.0	78	50	0.57	20-24XEMQ1	210	210
1 1/2	38	38	1 1/2	1 7/8-12UN	38	60.3	66	8.0	78	50	0.57	24XEMQ1	210	210

6000 PSI Series

1/2	13	12	1/2	3/4-16UNF	12	31.8	44	7.7	50	22	0.20	8XEMQ2	350	350
1/2	13	14, 15, 16	5/8	7/8-14UNF	12	31.8	44	7.7	50	22	0.20	10-8XEMQ2	350	350
3/4	19	14, 15, 16	5/8	7/8-14UNF	18	41.3	53	8.7	64	27	0.29	10-12XEMQ2	350	350
3/4	19	18, 20	3/4	1 1/16-12UN	18	41.3	53	8.7	64	27	0.29	12XEMQ2	350	350
3/4	19	25	1	1 5/16-12UN	18	41.3	53	8.7	64	27	0.29	16-12XEMQ2	350	350
1	25	18, 20	3/4	1 1/16-12UN	22	47.6	60	9.5	62	34	0.39	12-16XEMQ2	350	350
1	25	25	1	1 5/16-12UN	22	47.6	60	9.5	62	34	0.39	16XEMQ2	350	350
1	25	30, 32	1 1/4	1 5/8-12UN	22	47.6	60	9.5	62	34	0.39	20-16XEMQ2	275	275
1 1/4	32	25	1	1 5/16-12UN	27	54.0	70	10.3	70	42	0.45	16-20XEMQ2	350	350
1 1/4	32	30, 32	1 1/4	1 5/8-12UN	27	54.0	70	10.3	72	42	0.45	20XEMQ2	275	275
1 1/2	38	30, 32	1 1/4	1 5/8-12UN	32	63.5	80	12.5	87	50	0.57	20-24XEMQ2	275	275
1 1/2	38	38	1 1/2	1 7/8-12UN	32	63.5	80	12.5	87	50	0.57	24XEMQ2	210	210

1) Pressure shown = Item deliverable

$$\frac{\text{PN (bar)}}{10} = \text{PN (MPa)}$$

See pages N16 and N19 for related flange halves depending on bolt sets.

Stainless steel parts may have dimensional deviations. Additional information on request.

 *Please add the **suffixes** below according to the material/surface required.

Order code suffixes			
Material	Suffix surface and material	Example only flange adapter	Standard sealing material (no additional suffix needed)
Steel, zinc plated, Cr(VI)-free	CF	8XEMQ1CF	NBR
Stainless steel	SS	8XEMQ1SS	VIT

XVQ SAE 45° Elbow flange adapter

SAE Flange / Triple-Lok® 37° flare end
(ISO 6162-1/-2)

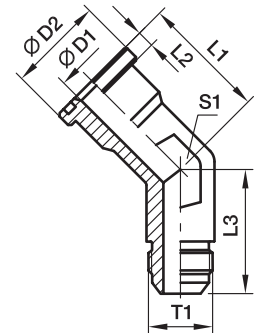

3000 PSI Series

Nom. flange size		Tube		T1	D1	D2	L1	L2	L3	S1	Weight (steel) kg/piece	Order code*	PN (bar) ¹⁾
SAE (in.)	ISO (DN)	(metr.)	(in.)										S
3/4	19	18, 20	3/4	1 1/16-12UN	15.5	38.1	40.1	6.7	32.3	36.0	0.29	12XVQ1	350
1	25	22, 25	7/8, 1	1 5/16-12UN	21.4	44.5	47.0	8.0	37.3	41.0	0.39	16XVQ1	350
1 1/4	32	28, 30, 32	1 1/4	1 5/8-12UN	27.4	50.8	61.0	8.0	40.4	47.5	0.45	20XVQ1	275
1 1/2	38	35, 38	1 1/2	1 7/8-12UN	33.3	60.3	73.7	8.0	45.2	63.5	0.57	24XVQ1	210
2	51	50	2	2 1/2-12UN	45.2	71.4	76.2	9.5	56.4	73.0	1.15	32XVQ1	138

6000 PSI Series

3/4	19	18, 20	3/4	1 1/16-12UN	15.5	41.3	46.5	8.8	32.3	36.0	0.42	12XVQ2	350
1	25	22, 25	7/8, 1	1 5/16-12UN	21.4	47.6	52.6	9.5	37.3	41.0	0.52	16XVQ2	350
1 1/4	32	28, 30, 32	1 1/4	1 5/8-12UN	27.4	54.0	61.0	10.3	40.4	47.5	0.56	20XVQ2	275
1 1/2	38	35, 38	1 1/2	1 7/8-12UN	33.3	63.5	73.7	12.6	45.2	63.5	0.69	24XVQ2	210

¹⁾Pressure shown = Item deliverable

$$\frac{\text{PN (bar)}}{10} = \text{PN (MPa)}$$

Stainless steel on request.

See pages N16 and N19 for related flange halves depending on bolt sets.

*Please add the **suffixes** below according to the material/surface required.

Material	Order code suffixes		
	Suffix surface and material	Example only flange adapter	Standard sealing material (no additional suffix needed)
Steel, oiled	S	12XVQ1-S	NBR

ASR SAE Straight flange adapter

SAE Flange / Butt weld reducer tube end
(ISO 6162-1/-2)

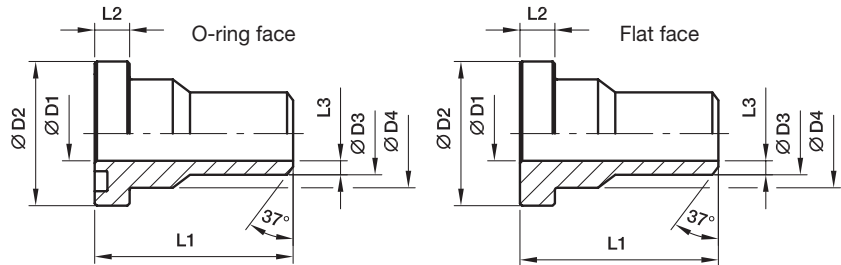

3000 PSI Series

Nom. flange size		Tube	D1	D2	D3	D4	L1	L2	L3	Weight (steel) kg/piece	O-ring face	Flat face	PN (bar ¹⁾)	
SAE (in.)	ISO (DN)										Order code*	Order code*	S	SS
1/2	13	18x4.5	10	30.2	18.0	24.0	45	6.7	4.0	0.12	ASR32/18X4.5	ASRG32/18X4.5	345	345
3/4	19	22x4.5	13	38.1	22.0	31.5	50	6.7	4.5	0.18	ASR33/22X4.5	ASRG33/22X4.5	345	345
1	25	28x4.5	19	44.4	28.0	38.0	55	8.0	4.5	0.26	ASR34/28X4.5	ASRG34/28X4.5	345	345
1 1/4	32	35x5.0	25	50.8	35.0	43.0	60	8.0	5.0	0.31	ASR35/35X5	ASRG35/35X5	276	276
1 1/2	38	43x6.0	31	60.3	43.0	50.0	65	8.0	6.0	0.51	ASR36/43X6	ASRG36/43X6	207	207
2	51	50x6.0	38	71.4	50.0	62.0	70	9.5	6.0	0.80	ASR38/50X6	ASRG38/50X6	207	207
2 1/2	64	62x7.5	47	84.1	62.0	74.0	75	9.5	7.5	1.24	ASR310/62X7.5	ASRG310/62X7.5	172	172
3	76	76x9.0	58	101.6	76.0	90.0	85	9.5	9.0	1.95	ASR312/76X9	ASRG312/76X9	138	138
3 1/2	89	90x10.0	70	114.3	90.0	102.0	90	11.2	10.0	2.15	ASR314/90X10	ASRG314/90X10	34	34
4	102	102x7.0	88	127.0	102.0	114.0	100	11.2	7.0	2.62	ASR316/102X7	ASRG316/102X7	34	34

6000 PSI Series

1/2	13	18x4.0	10	31.8	18.0	24.0	45	7.7	4.0	0.12	ASR62/18X4	ASRG62/18X4	420	420
3/4	19	22x4.5	13	41.3	22.0	32.0	50	8.7	4.5	0.20	ASR63/22X4.5	ASRG63/22X4.5	420	420
1	25	28x5.0	18	47.6	28.0	38.0	55	9.5	5.0	0.31	ASR64/28X5	ASRG64/28X5	420	420
1 1/4	32	35x6.5	22	54.0	35.0	44.0	60	10.3	6.5	0.46	ASR65/35X6.5	ASRG65/35X6.5	420	420
1 1/2	38	44x7.5	29	63.5	44.0	51.0	65	12.5	7.5	0.69	ASR66/44X7.5	ASRG66/44X7.5	420	420
2	51	51x8.0	35	79.4	51.0	67.0	70	12.5	8.0	1.24	ASR68/51X8	ASRG68/51X8	420	420

¹⁾Pressure shown = Item deliverable

$$\frac{\text{PN (bar)}}{10} = \text{PN (MPa)}$$

The pressures given here are the maximum allowable for the flange fittings. If the pipe or tube used has a lower pressure rating, then the welded assembly rating will be the lower one, assuming the weld is adequately strong.

See pages N16 - N20 for related flanges or flange halves depending on bolt sets.

Stainless steel parts may have dimensional deviations. Additional information on request.

*Please add the **suffixes** below according to the material/surface required.

Order code suffixes					
Material	Suffix surface and material	Example only flange adapter	Example incl. splitflanges, metr. bolts and O-ring	Example incl. splitflanges, UNC bolts and O-ring	Standard sealing material (no additional suffix needed)
Steel, oil dipped	S	ASR32/18X4.5S	ASR32/18X4.5SM	ASR32/18X4.5SU	NBR
Stainless steel	SS	ASR32/18X4.5SS	ASR32/18X4.5SSM	-	VIT

AS SAE Straight flange adapter

SAE Flange / Butt weld tube end
(ISO 6162-1/-2)

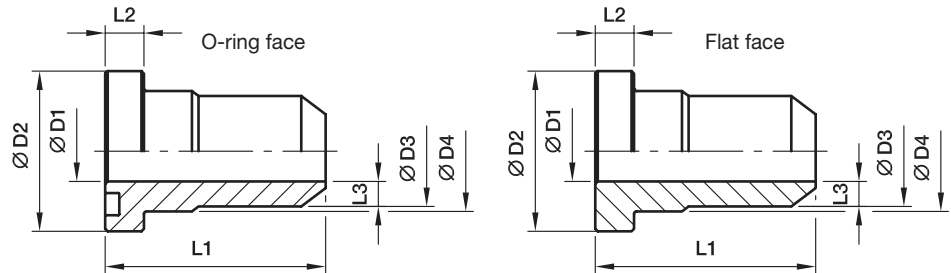

3000 PSI Series

Nom. flange size		Tube	D1	D2	D3	D4	L1	L2	L3	Weight (steel) kg/piece	O-ring face	Flat face	PN (bar) ¹⁾	
SAE (in.)	ISO (DN)										Order code*	Order code*	S	SS
1/2	13	15x2.0	11	30.2	15	23.9	45	6.8	2.0	0.09	AS32/15X2	ASG32/15X2	345	345
1/2	13	16x3.0	10	30.2	16	23.9	45	6.8	3.0	0.10	AS32/16X3	ASG32/16X3	345	345
1/2	13	21.3x2.6	13	30.2	22	23.9	45	6.8	4.5	0.12	AS32/21.3X2.6	ASG32/21.3X2.6	345	345
3/4	19	18x1.5	15	38.1	18	31.5	50	6.8	1.5	0.14	AS33/18X1.5	ASG33/18X1.5	345	345
3/4	19	22x2.0	18	38.1	22	31.5	50	6.8	2.0	0.12	AS33/22X2	ASG33/22X2	345	345
3/4	19	20x3.0	14	38.1	20	31.5	50	6.8	3.0	0.14	AS33/20X3	ASG33/20X3	345	345
3/4	19	25x4.0	17	38.1	25	31.5	50	6.8	4.0	0.17	AS33/25X4	ASG33/25X4	345	345
3/4	19	26.9x2.6	19	38.1	28	31.5	50	6.8	4.5	0.18	AS33/26.9X2.6	ASG33/26.9X2.6	345	345
1	25	20x2.5	15	44.5	20	38.0	55	8.0	2.5	0.26	AS34/20X2.5	ASG34/20X2.5	345	345
1	25	28x2.0	24	44.5	28	38.0	55	8.0	2.0	0.19	AS34/28X2	ASG34/28X2	345	345
1	25	30x4.5	21	44.5	30	38.0	55	8.0	4.5	0.26	AS34/30X4.5	ASG34/30X4.5	345	345
1	25	33.7x4.0	25	44.4	35	38.0	55	8.0	5.0	0.26	AS34/33.7X4	ASG34/33.7X4	345	345
1 1/4	32	35x2.0	31	50.8	35	43.0	60	8.0	2.0	0.31	AS35/35X2	ASG35/35X2	276	276
1 1/4	32	25x3.0	19	50.8	25	43.0	60	8.0	3.0	0.45	AS35/25X3	ASG35/25X3	276	276
1 1/4	32	30x4.0	22	50.8	30	43.0	60	8.0	4.0	0.45	AS35/30X4	ASG35/30X4	276	276
1 1/4	32	38x5.0	28	50.8	38	43.0	60	8.0	5.0	0.40	AS35/38X5	ASG35/38X5	276	276
1 1/4	32	42.4x6.0	31	50.8	43	43.0	60	8.0	6.0	0.34	AS35/42.4X5	ASG35/42.4X5	276	276
1 1/2	38	42x3.0	36	60.3	42	50.0	65	8.0	3.0	0.47	AS36/42X3	ASG36/42X3	207	207
1 1/2	38	38x4.0	30	60.3	38	50.0	65	8.0	4.0	0.57	AS36/38X4	ASG36/38X4	207	207
1 1/2	38	48.3x6.0	38	60.3	50	50.0	65	8.0	6.0	0.48	AS36/48.3X6	ASG36/48.3X6	207	207
2	51	50x6.0	38	71.4	50	62.0	70	9.5	6.0	0.96	AS38/50X6	ASG38/50X6	207	207
2	51	65x8.0	49	71.4	65	62.0	70	9.5	8.0	0.64	AS38/65X8	ASG38/65X8	207	207
2	51	60.3x7.5	47	71.4	62	62.0	70	9.5	7.5	0.78	AS38/62X7.5	ASG38/62X7.5	207	207
2 1/2	64	76.1x5.5	63	84.1	74	74.0	75	9.5	5.5	0.80	AS310/74X5.5	ASG310/74X5.5	172	172
3	76	88.9x10.0	70	101.6	90	90.0	85	9.5	10.0	1.78	AS312/90X10	ASG312/90X10	138	138
3 1/2	89	101.6x7.0	88	114.3	102	102.0	90	11.2	7.0	1.65	AS314/102X7	ASG314/102X7	34	34
4	102	114x8.0	98	127.0	114	114.0	100	11.2	8.0	2.34	AS316/115X8.5	ASG316/115X8.5	34	34
5	127	139.7x10.0	120	152.4	140	140.0	100	11.2	10.0	3.61	AS320/140X10	ASG320/140X10	34	34

¹⁾Pressure shown = Item deliverable

$$\frac{PN \text{ (bar)}}{10} = PN \text{ (MPa)}$$

The pressures given here are the maximum allowable for the flange fittings. If the pipe or tube used has a lower pressure rating, then the welded assembly rating will be the lower one, assuming the weld is adequately strong.

See pages N16 - N20 for related flanges or flange halves depending on bolt sets.

Stainless steel parts may have dimensional deviations. Additional information on request.

*Please add the **suffixes** below according to the material/surface required.

Order code suffixes					
Material	Suffix surface and material	Example only flange adapter	Example incl. splitflanges, metr. bolts and O-ring	Example incl. splitflanges, UNC bolts and O-ring	Standard sealing material (no additional suffix needed)
Steel, oil dipped	S	AS32/15X2S	AS32/15X2SM	AS32/15X2SU	NBR
Stainless steel	SS	AS32/15X2SS	AS32/15X2SSM	-	VIT

AS SAE Straight flange adapter

SAE Flange / Butt weld tube end
(ISO 6162-1/-2)

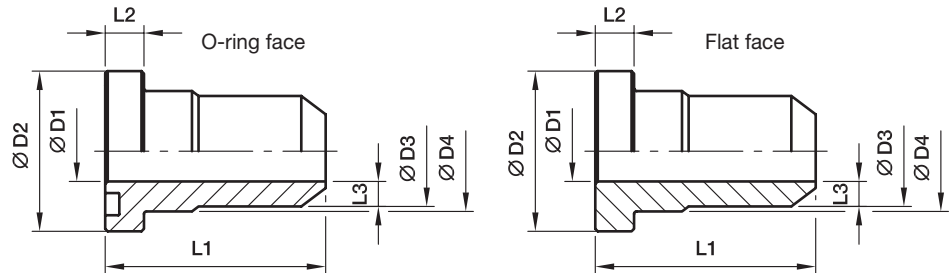

6000 PSI Series

Nom. flange size		Tube	D1	D2	D3	D4	L1	L2	L3	Weight (steel) kg/piece	O-ring face	Flat face	PN (bar ¹⁾)	
SAE (in.)	ISO (DN)										Order code*	Order code*	S	SS
1/2	13	16×3.0	10	31.8	16	24.0	45	7.8	3.0	0.12	AS62/16X3	ASG62/16X3	420	420
1/2	13	21.3×3.2	13	31.8	22	24.0	45	7.8	4.5	0.12	AS62/21.3X3.2	ASG62/21.3X3.2	420	420
3/4	19	16×3.0	10	41.3	16	31.8	50	8.8	3.0	0.20	AS63/16X3	ASG63/16X3	420	420
3/4	19	20×4.0	12	41.3	20	31.8	50	8.8	4.0	0.19	AS63/20X4	ASG63/20X4	420	420
3/4	19	26.9×4.0	18	41.3	28	32.0	50	8.8	5.0	0.21	AS63/26.9X4	ASG63/26.9X4	420	420
3/4	19	25×5.0	15	41.3	25	31.8	50	8.8	5.0	0.21	AS63/25X5	ASG63/25X5	420	420
1	25	25×5.0	15	47.6	25	38.0	55	9.5	5.0	0.30	AS64/25X5	ASG64/25X5	420	420
1	25	30×4.0	22	47.6	30	38.0	55	9.5	4.0	0.27	AS64/30X4	ASG64/30X4	420	420
1	25	30×6.0	18	47.3	30	38.0	67	9.5	6.0	0.33	AS64/30X6	ASG64/30X6	420	420
1	25	33.7×6.3	22	47.6	35	38.0	55	9.5	6.5	0.32	AS64/33.7X6.3	ASG64/33.7X6.3	420	420
1 1/4	32	30×4.0	22	54.0	30	44.0	60	10.3	4.0	0.48	AS65/30X4	ASG65/30X4	420	420
1 1/4	32	30×6.0	18	54.0	30	44.0	60	10.3	6.0	0.54	AS65/30X6	ASG65/30X6	420	420
1 1/4	32	38×5.0	28	54.0	38	44.0	60	10.3	5.0	0.45	AS65/38X5	ASG65/38X5	420	420
1 1/4	32	38×8.0	22	54.0	38	44.0	60	10.3	8.0	0.54	AS65/38X8	ASG65/38X8	420	420
1 1/4	32	42.4×6.3	29	54.0	44	44.0	60	10.3	7.5	0.48	AS65/42.4X6.3	ASG65/42.4X6.3	420	420
1 1/2	38	38×5.0	28	63.5	38	50.8	65	12.5	5.0	0.72	AS66/38X5	ASG66/38X5	420	420
1 1/2	38	38×8.0	22	63.5	38	50.8	65	12.5	8.0	0.85	AS66/38X8	ASG66/38X8	420	420
1 1/2	38	48.3×8.0	35	63.5	51	51.0	65	12.5	8.0	0.66	AS66/48.3X8	ASG66/48.3X8	420	420
2	51	50×9.0	32	79.4	50	66.6	70	12.5	9.0	1.24	AS68/50X9	ASG68/50X9	420	420
2	51	65×8.0	49	79.4	65	66.6	70	12.5	8.0	0.98	AS68/65X8	ASG68/65X8	420	420
2	51	60.3×10.0	43	79.4	61	67.0	70	12.5	9.0	1.12	AS68/60.3X10	ASG68/60.3X10	420	420
2 1/2	64	73×14.0	45	107.8	74	88.9	90	20.6	14.5	3.38	AS610/73X14	ASG610/73X14	420	420
3	76	88.6×16.0	58	131.7	90	113.8	110	25.6	16.0	6.70	AS612/88.6X16	ASG612/88.6X16	420	420

¹⁾Pressure shown = Item deliverable

$$\frac{\text{PN (bar)}}{10} = \text{PN (MPa)}$$

The pressures given here are the maximum allowable for the flange fittings. If the pipe or tube used has a lower pressure rating, then the welded assembly rating will be the lower one, assuming the weld is adequately strong.

See pages N16 - N20 for related flanges or flange halves depending on bolt sets.

Stainless steel parts may have dimensional deviations. Additional information on request.

*Please add the **suffixes** below according to the material/surface required.

Order code suffixes					
Material	Suffix surface and material	Example only flange adapter	Example incl. splitflanges, metr. bolts and O-ring	Example incl. splitflanges, UNC bolts and O-ring	Standard sealing material (no additional suffix needed)
Steel, oil dipped	S	AS62/16X3S	AS62/16X3SM	AS62/16X3SU	NBR
Stainless steel	SS	AS62/16X3SS	AS62/16X3SSM	-	VIT

ASL SAE Straight flange adapter

SAE Flange / Butt weld tube end
(ISO 6162-1/-2)

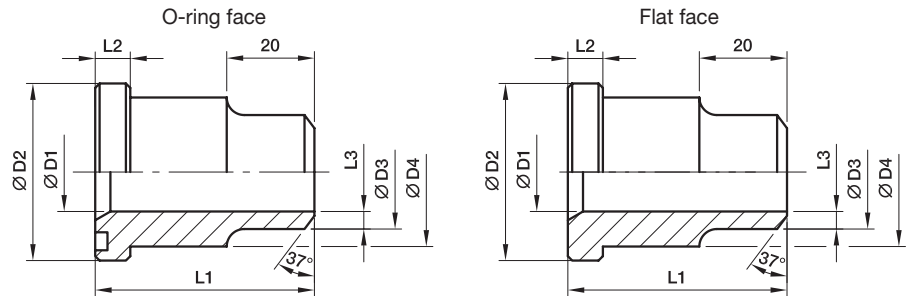

3000 PSI Series

Nom. flange size		Tube	D1	D2	D3	D4	L1	L2	L3	Weight (steel) kg/piece	O-ring face	Flat face	PN (bar) ¹⁾	
SAE (in.)	ISO (DN)										Order code*	Order code*	S	SS
1/2	13	16x2.0	12	30.2	16	23.9	41	6.7	2.5	0.26	ASL32/16X2	ASLG32/16X2	210	210
3/4	19	25x3.0	19	38.1	25	31.7	50	6.7	3.0	0.45	ASL33/25X3	ASLG33/25X3	210	210
1	25	30x4.0	22	44.4	30	38.0	50	8.0	4.0	0.25	ASL34/30X4	ASLG34/30X4	210	210
1 1/4	32	38x5.0	28	50.8	38	43.0	55	8.0	5.0	0.36	ASL35/38X5	ASLG35/38X5	210	210
1 1/2	38	45x5.0	35	60.3	45	50.0	57	8.0	5.0	0.45	ASL36/45X5	ASLG36/45X5	210	210
2	51	60x7.0	45	71.4	60	62.0	57	9.5	7.5	0.65	ASL38/60X7	ASLG38/60X7	210	210
2 1/2	64	70x7.5	55	84.1	70	74.0	58	9.5	7.5	0.89	ASL310/70X7.5	ASLG310/70X7.5	175	175
3	76	80x6.0	68	101.6	80	90.0	60	9.5	6.0	1.18	ASL312/80X6	ASLG312/80X6	138	138
3 1/2	89	100x6.0	88	114.3	100	102.0	60	11.2	6.0	1.10	ASL314/100X6	ASLG314/100X6	35	35
4	102	110x6.0	98	127.0	110	114.0	60	11.2	6.0	1.43	ASL316/110X6	ASLG316/110X6	35	35
5	127	133x6.5	120	152.4	133	140.0	60	11.2	6.5	2.22	ASL320/133X6.5	ASLG320/133X6.5	35	35

6000 PSI Series

1/2	13	16x2.0	12	31.8	17	24.0	34	7.7	2.0	0.09	ASL62/16X2	ASLG62/16X2	420	420
3/4	19	25x3.5	18	41.3	25	32.0	38	8.7	3.5	0.16	ASL63/25X3.5	ASLG63/25X3.5	420	420
1	25	30x4.0	22	47.6	30	38.5	40	9.5	4.0	0.22	ASL64/30X4	ASLG64/30X4	420	420
1 1/4	32	38x5.5	27	54.0	38	44.0	45	10.3	5.5	0.35	ASL65/38X5.5	ASLG65/38X5.5	420	420
1 1/2	38	45x6.5	32	63.5	45	51.0	50	12.5	6.5	0.53	ASL66/45X6.5	ASLG66/45X6.5	420	420
2	51	60x7.5	45	79.4	60	67.0	58	12.5	7.5	0.91	ASL68/60X7.5	ASLG68/60X7.5	420	420
2 1/2	64	74x14.5	45	107.8	74	88.9	90	20.6	14.5	3.45	ASL610/74X14.5	ASLG610/74X14.5	420	420
3	76	90x16.0	58	131.7	90	113.8	110	25.6	16.0	9.62	ASL612/90X16	ASLG612/90X16	420	420

¹⁾ Pressure shown = Item deliverable

$$\frac{PN \text{ (bar)}}{10} = PN \text{ (MPa)}$$

The pressures given here are the maximum allowable for the flange fittings. If the pipe or tube used has a lower pressure rating, then the welded assembly rating will be the lower one, assuming the weld is adequately strong.

See pages N16 - N20 for related flanges or flange halves depending on bolt sets.

Stainless steel parts may have dimensional deviations. Additional information on request.

*Please add the **suffixes** below according to the material/surface required.

Order code suffixes					
Material	Suffix surface and material	Example only flange adapter	Example incl. splitflanges, metr. bolts and O-ring	Example incl. splitflanges, UNC bolts and O-ring	Standard sealing material (no additional suffix needed)
Steel, oil dipped	S	ASL32/16X2S	ASL32/16X2SM	ASL32/16X2SU	NBR
Stainless steel	SS	ASL32/16X2SS	ASL32/16X2SSM	-	VIT

WAS SAE 90° Elbow flange adapter

SAE Flange / Butt weld tube end
(ISO 6162-1/-2)

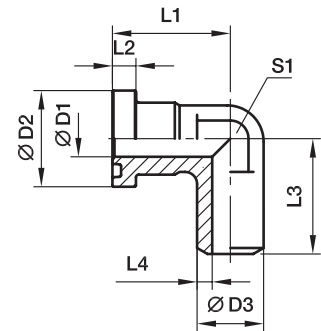

3000 PSI Series

Nom. flange size		max.	D1	D2	D3	L1	L2	L3	L4	S1	Weight (steel) kg/piece	Order code*	PN (bar) ¹⁾	
SAE (in.)	ISO (DN)												S	SS
1/2	13	21.3	13	30.2	21.6	44	6.7	50	4.3	22	0.22	WAS32/21.6	345	345
3/4	19	26.9	19	38.1	27.2	53	6.7	64	4.1	27	0.35	WAS33/27.2	345	345
1	25	33.7	25	44.4	34.5	60	8.0	65	4.7	34	0.52	WAS34/34.5	345	345
1 1/4	32	42.4	30	50.8	42.8	55	8.0	64	6.4	42	0.78	WAS35/42.8	276	276
1 1/2	38	48.3	38	60.3	48.6	66	8.0	78	5.3	50	1.04	WAS36/48.6	207	207

6000 PSI Series

1/2	13	21.3	13	31.8	21.6	44	7.7	50	4.3	22	0.35	WAS62/21.6	420	420
3/4	19	26.9	18	41.3	27.2	53	8.7	64	4.6	27	0.41	WAS63/27.2	420	420
1	25	33.7	22	47.6	34.5	60	9.5	62	6.3	34	0.64	WAS64/34.5	420	420
1 1/4	32	42.4	28	54.0	42.8	70	10.3	72	7.4	42	1.05	WAS65/42.8	420	420
1 1/2	38	48.3	32	63.5	48.6	80	12.5	84	8.3	50	1.58	WAS66/48.6	420	420

¹⁾Pressure shown = Item deliverable

$$\frac{PN \text{ (bar)}}{10} = PN \text{ (MPa)}$$

The pressures given here are the maximum allowable for the flange fittings. If the pipe or tube used has a lower pressure rating, then the welded assembly rating will be the lower one, assuming the weld is adequately strong.

See pages N16 - N20 for related flanges or flange halves depending on bolt sets.

Stainless steel parts may have dimensional deviations. Additional information on request.

*Please add the **suffixes** below according to the material/surface required.

Order code suffixes					
Material	Suffix surface and material	Example only flange adapter	Example incl. splitflanges, metr. bolt and O-ring	Example incl. splitflanges, UNC bolt and O-ring	Standard sealing material (no additional suffix needed)
Steel, oil dipped	S	WAS32/21.6S	WAS32/21.6SM	WAS32/21.6SU	NBR
Stainless steel	SS	WAS32/21.6SS	WAS32/21.6SSM	-	VIT

ES SAE Straight flange adapter

SAE Flange / Socket weld tube end
(ISO 6162-1/-2)

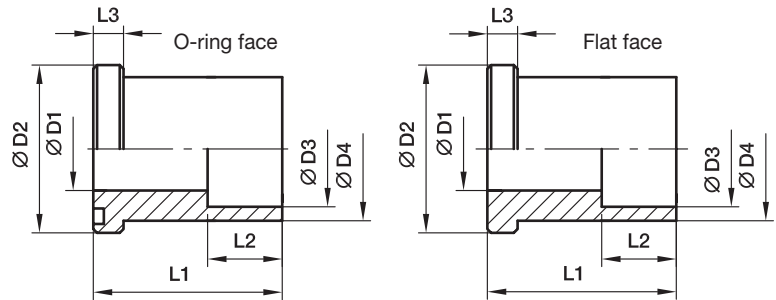

3000 PSI Series

Nom. flange size		max.	D1	D2	D3	D4	L1	L2	L3	Weight (steel) kg/piece	O-ring face Order code*	Flat face Order code*	PN (bar) ¹⁾	
SAE (in.)	ISO (DN)												S	SS
1/2	13	16.0	12.5	30.2	16.5	24.0	35	12	6.7	0.11	ES32/16.5	ESG32/16.5	345	345
1/2	13	17.3	12.5	30.2	17.6	24.0	35	12	6.7	0.12	ES32/17.6	ESG32/17.6	345	345
3/4	19	20.0	15.0	38.1	20.5	31.5	40	13	6.7	0.20	ES33/20.5	ESG33/20.5	345	345
3/4	19	21.3	15.0	38.1	21.7	31.5	40	13	6.7	0.20	ES33/21.7	ESG33/21.7	345	345
1	25	25.0	20.0	44.4	25.5	38.0	45	14	8.0	0.30	ES34/25.5	ESG34/25.5	345	345
1	25	26.9	20.0	44.4	27.3	38.0	45	14	8.0	0.28	ES34/27.3	ESG34/27.3	345	345
1 1/4	32	30.0	25.0	50.8	30.5	43.0	50	16	8.0	0.39	ES35/30.5	ESG35/30.5	276	276
1 1/4	32	32.0	25.0	50.8	32.5	43.0	50	16	8.0	0.37	ES35/32.5	ESG35/32.5	276	276
1 1/4	32	33.7	25.0	50.8	34.2	43.0	50	16	8.0	0.35	ES35/34.2	ESG35/34.2	276	276
1 1/2	38	38.0	32.0	60.3	38.5	50.0	55	18	8.0	0.52	ES36/38.5	ESG36/38.5	207	207
1 1/2	38	40.0	32.0	60.3	40.7	50.0	55	18	8.0	0.49	ES36/40.7	ESG36/40.7	207	207
1 1/2	38	42.4	32.0	60.3	43.0	50.0	55	18	8.0	0.47	ES36/43	ESG36/43	207	207
2	51	48.3	32.0	71.4	49.0	62.0	65	20	9.5	0.95	ES38/49	ESG38/49	207	207
2	51	50.0	38.0	71.4	50.7	62.0	65	20	9.5	0.87	ES38/50.7	ESG38/50.7	207	207
2 1/2	64	60.3	38.0	84.1	61.0	74.0	75	22	9.5	1.46	ES310/61	ESG310/61	172	172
2 1/2	64	63.5	47.0	84.1	64.0	74.0	75	22	9.5	1.37	ES310/64	ESG310/64	172	172
3	76	73.5	47.0	101.6	74.0	90.0	85	24	9.5	2.30	ES312/74	ESG312/74	138	138
3	76	76.1	58.0	101.6	77.0	90.0	85	24	9.5	2.23	ES312/77	ESG312/77	138	138
3	76	80.0	58.0	101.6	81.0	90.0	85	24	9.5	2.13	ES312/81	ESG312/81	138	138

¹⁾Pressure shown = Item deliverable

$$\frac{\text{PN (bar)}}{10} = \text{PN (MPa)}$$

The pressures given here are the maximum allowable for the flange fittings. If the pipe or tube used has a lower pressure rating, then the welded assembly rating will be the lower one, assuming the weld is adequately strong.

See pages N16 - N20 for related flanges or flange halves depending on bolt sets.

Stainless steel parts may have dimensional deviations. Additional information on request.

*Please add the **suffixes** below according to the material/surface required.

Order code suffixes					
Material	Suffix surface and material	Example only flange adapter	Example incl. splitflanges, metr. bolts and O-ring	Example incl. splitflanges, UNC bolts and O-ring	Standard sealing material (no additional suffix needed)
Steel, oil dipped	S	ES32/16.5S	ES32/16.5SM	ES32/16.5SU	NBR
Stainless steel	SS	ES32/16.5SS	ES32/16.5SSM	-	VIT

ES SAE Straight flange adapter

SAE Flange / Socket weld tube end
(ISO 6162-1/-2)

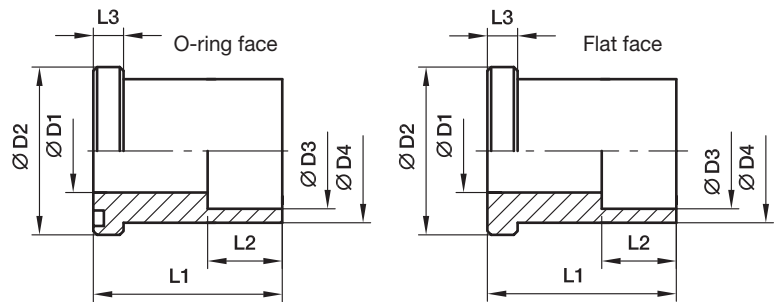

6000 PSI Series

Nom. flange size		max.	D1	D2	D3	D4	L1	L2	L3	Weight (steel) kg/piece	O-ring face Order code*	Flat face Order code*	PN (bar) ¹⁾	
SAE (in.)	ISO (DN)												S	SS
1/2	13	16.0	11.0	31.8	16.5	24.0	35	13	7.7	0.26	ES62/16.5	ESG62/16.5	420	420
1/2	13	17.3	11.0	31.8	17.6	24.0	35	13	7.7	0.24	ES62/17.6	ESG62/17.6	420	420
3/4	13	20.0	15.0	41.3	20.5	31.8	40	13	8.7	0.22	ES63/20.5	ESG63/20.5	420	420
3/4	19	21.3	15.0	41.3	21.7	31.8	40	13	8.7	0.19	ES63/21.7	ESG63/21.7	420	420
1	25	25.0	20.0	47.6	25.5	38.0	45	13	9.5	0.32	ES64/25.5	ESG64/25.5	420	420
1	25	26.9	20.0	47.6	27.3	38.0	45	13	9.5	0.31	ES64/27.3	ESG64/27.3	420	420
1 1/4	32	30.0	24.0	54.0	30.5	44.0	50	16	10.3	0.43	ES65/30.5	ESG65/30.5	420	420
1 1/4	32	32.0	24.0	54.0	32.5	44.0	50	16	10.3	0.43	ES65/32.5	ESG65/32.5	420	420
1 1/4	32	33.7	24.0	54.0	34.2	44.0	50	16	10.3	0.45	ES65/34.2	ESG65/34.2	420	420
1 1/2	38	38.0	31.0	63.5	38.5	51.0	55	18	12.5	0.63	ES66/38.5	ESG66/38.5	420	420
1 1/2	38	40.0	31.0	63.5	40.7	51.0	55	18	12.5	0.60	ES66/40.7	ESG66/40.7	420	420
1 1/2	38	42.4	31.0	63.5	42.8	51.0	55	18	12.5	0.57	ES66/42.8	ESG66/42.8	420	420
2	51	48.3	38.0	79.4	49.0	67.0	65	20	12.5	1.24	ES68/49	ESG68/49	420	420
2	51	50.0	38.0	79.4	50.7	67.0	65	20	12.5	1.22	ES68/50.7	ESG68/50.7	420	420

¹⁾ Pressure shown = Item deliverable

$$\frac{\text{PN (bar)}}{10} = \text{PN (MPa)}$$

The pressures given here are the maximum allowable for the flange fittings. If the pipe or tube used has a lower pressure rating, then the welded assembly rating will be the lower one, assuming the weld is adequately strong.

See pages N16 - N20 for related flanges or flange halves depending on bolt sets.

Stainless steel parts may have dimensional deviations. Additional information on request.

*Please add the **suffixes** below according to the material/surface required.

Order code suffixes					
Material	Suffix surface and material	Example only flange adapter	Example incl. splitflanges, metr. bolts and O-ring	Example incl. splitflanges, UNC bolts and O-ring	Standard sealing material (no additional suffix needed)
Steel, oil dipped	S	ES62/16.5S	ES62/16.5SM	ES62/16.5SU	NBR
Stainless steel	SS	ES62/16.5SS	ES62/16.5SSM	-	VIT

ESL SAE Straight flange adapter

SAE Flange / Socket weld tube end
(ISO 6162-1/-2)

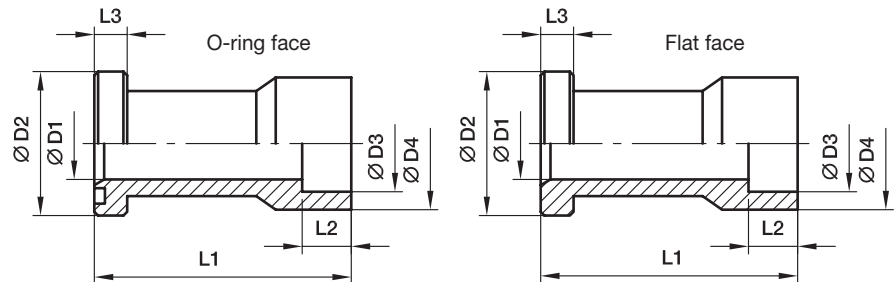

3000 PSI Series

Nom. flange size		max.	D1	D2	D3	D4	L1	L2	L3	Weight (steel) kg/piece	O-ring face Order code*	Flat face Order code*	PN (bar) ¹⁾	
SAE (in.)	ISO (DN)												S	SS
1/2	13	20.0	15	30.2	20.5	30	60	13	6.7	0.45	ESL32/20.5	ESLG32/20.5	345	345
1/2	13	21.3	15	30.2	21.7	30	60	13	6.7	0.44	ESL32/21.7	ESLG32/21.7	345	345
3/4	19	25.0	19	38.1	25.5	35	68	13	6.7	0.60	ESL33/25.5	ESLG33/25.5	345	345
3/4	19	26.9	19	38.1	27.3	35	68	13	6.7	0.30	ESL33/27.3	ESLG33/27.3	345	345
1	25	30.0	23	44.4	30.5	44	75	16	8.0	0.75	ESL34/30.5	ESLG34/30.5	345	345
1	25	32.0	24	44.4	32.5	44	75	16	8.0	0.72	ESL34/32.5	ESLG34/32.5	345	345
1	25	33.7	25	44.4	34.0	44	75	16	8.0	0.44	ESL34/34	ESLG34/34	345	345
1	25	35.0	25	44.4	35.5	44	75	16	8.0	0.42	ESL34/35.5	ESLG34/35.5	345	345
1 1/4	32	38.0	32	50.8	38.5	55	95	18	8.0	0.67	ESL35/38.5	ESLG35/38.5	276	276
1 1/4	32	40.0	32	50.8	40.5	55	95	18	8.0	0.95	ESL35/40.5	ESLG35/40.5	276	276
1 1/4	32	42.4	32	50.8	43.0	55	95	18	8.0	0.63	ESL35/43	ESLG35/43	276	276
1 1/2	38	48.3	38	60.3	49.0	68	100	20	8.0	0.94	ESL36/49	ESLG36/49	207	207
1 1/2	38	50.0	38	60.3	50.4	68	100	20	8.0	0.88	ESL36/50.4	ESLG36/50.4	207	207
2	51	60.3	50	71.4	61.0	79	107	22	9.5	1.34	ESL38/61	ESLG38/61	207	207
2	51	65.0	50	71.4	65.8	79	107	22	9.5	1.80	ESL38/65.8	ESLG38/65.8	207	207
2 1/2	64	73.0	58	84.1	74.0	98	130	24	9.5	2.30	ESL310/74	ESLG310/74	172	172
2 1/2	64	76.1	58	84.1	77.0	98	130	24	9.5	2.25	ESL310/77	ESLG310/77	172	172
2 1/2	64	80.0	58	84.1	81.0	98	130	24	9.5	2.15	ESL310/81	ESLG310/81	172	172
3	76	88.9	70	101.6	90.5	116	150	28	9.5	3.00	ESL312/90.5	ESLG312/90.5	138	138

6000 PSI Series

1/2	13	20.0	15	31.8	20.5	32	60	13	7.7	0.45	ESL62/20.5	ESLG62/20.5	420	420
1/2	13	21.3	15	31.8	21.7	32	60	13	7.7	0.44	ESL62/21.7	ESLG62/21.7	420	420
1/2	13	22.0	15	31.8	22.5	32	60	13	7.7	0.65	ESL62/22.5	ESLG62/22.5	420	420
3/4	19	25.0	19	41.3	25.7	40	68	13	8.7	0.38	ESL63/25.7	ESLG63/25.7	420	420
3/4	19	26.9	19	41.3	27.3	40	68	13	8.7	0.61	ESL63/27.3	ESLG63/27.3	420	420
3/4	19	28.0	19	41.3	28.7	40	68	13	8.7	0.37	ESL63/28.7	ESLG63/28.7	420	420
1	25	33.7	25	47.6	34.0	48	75	16	9.5	0.75	ESL64/34	ESLG64/34	420	420
1	25	35.0	25	47.6	35.5	48	75	16	9.5	0.73	ESL64/35.5	ESLG64/35.5	420	420

¹⁾Pressure shown = Item deliverable

$$\frac{\text{PN (bar)}}{10} = \text{PN (MPa)}$$

The pressures given here are the maximum allowable for the flange fittings. If the pipe or tube used has a lower pressure rating, then the welded assembly rating will be the lower one, assuming the weld is adequately strong.

See pages N16 and N19 for related flange halves depending on bolt sets.

Stainless steel parts may have dimensional deviations. Additional information on request.

*Please add the **suffixes** below according to the material/surface required.

Order code suffixes					
Material	Suffix surface and material	Example only flange adapter	Example incl. splitflanges, metr. bolts and O-ring	Example incl. splitflanges, UNC bolts and O-ring	Standard sealing material (no additional suffix needed)
Steel, oil dipped	S	ESL32/20.5S	ESL32/20.5SM	ESL32/20.5SU	NBR
Stainless steel	SS	ESL32/20.5SS	ESL32/20.5SSM	-	VIT

PFF-G SAE Straight 4 bolt flange with BSPP thread

SAE Flange / Female BSPP thread
(ISO 6162-1/-2)

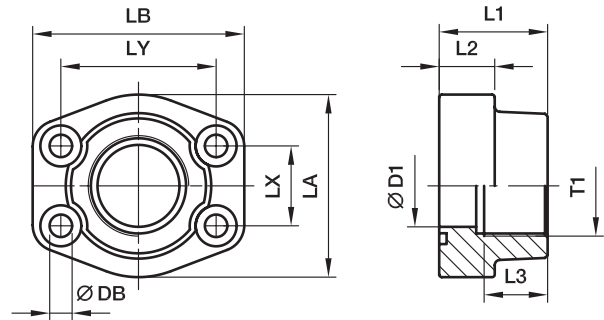

3000 PSI Series

Nom. flange size		T1	D1	L1	L2	L3	LA	LB	LX	LY	DB	Weight (steel) kg/piece	Order code*	PN (bar) ¹⁾	
SAE (in.)	ISO (DN)													S	SS
1/2	13	G 3/8	13	36	16	18	46	57	17.5	38.1	8.9	0.31	PFF32G38	345	345
1/2	13	G 1/2	13	36	16	18	46	54	17.5	38.1	8.9	0.28	PFF32G	345	345
3/4	19	G 3/4	19	36	18	18	52	65	22.2	47.6	10.6	0.39	PFF33G	345	345
3/4	19	G 1/2	13	36	18	18	52	65	22.2	47.6	10.6	0.42	PFF33G12	345	345
1	25	G 1	25	38	18	20	59	70	26.2	52.4	10.6	0.48	PFF34G	345	345
1	25	G 3/4	19	38	18	18	59	70	26.2	52.4	10.6	0.56	PFF34G34	345	345
1 1/4	32	G 1 1/4	31	41	21	22	68	79	30.2	58.7	10.6***	0.76	PFF35G	276	276
1 1/4	32	G 1	25	41	21	20	68	79	30.2	58.7	10.6***	0.89	PFF35G1	276	276
1 1/2	38	G 1 1/2	38	44	25	24	78	93	35.7	69.9	13.3	1.12	PFF36G	207	207
1 1/2	38	G 1 1/4	32	45	27	22	78	93	35.7	69.9	13.3	1.21	PFF36G114	207	207
2	51	G 2	50	45	25	26	89	103	42.9	77.8	13.5	1.32	PFF38G	207	207
2	51	G 1 1/2	38	45	25	24	89	103	42.9	77.8	13.5	1.65	PFF38G112	207	207
2 1/2	64	G 2 1/2	63	50	25	30	108	114	50.8	88.9	13.5	1.73	PFF310G	172	172
2 1/2	64	G 2	51	50	25	30	108	114	50.8	88.9	13.5	2.20	PFF310G2	172	172
3	76	G 3	73	50	27	34	124	135	61.9	106.4	17.5	2.38	PFF312G	138	138
3	76	G 2 1/2	63	50	27	30	124	135	61.9	106.4	16.7	2.57	PFF312G212	138	138
3 1/2	89	G 3 1/2	89	48	27	34	136	152	69.9	120.7	16.7	2.50	PFF314G	34	34
3 1/2	89	G 3	73	48	27	34	136	152	69.9	120.7	16.7	3.10	PFF314G3	34	34
4	102	G 4	99	48	27	34	146	162	77.8	130.2	16.7	2.65	PFF316G	34	34
4	102	G 3 1/2	89	48	27	34	146	162	77.8	130.2	16.7	3.30	PFF316G312	34	34
5	127	G 5	120	50	28	30	180	184	92.1	152.4	16.7	5.80	PFF320G	34	34

6000 PSI Series

1/2	13	G 3/8	13	36	16	18	46	57	18.2	40.5	8.9	0.29	PFF62G38	420	420
1/2	13	G 1/2	13	36	16	15	46	57	18.2	40.5	8.9	0.30	PFF62G	420	420
3/4	19	G 3/4	19	36	19	18	55	71	23.8	50.8	10.6	0.53	PFF63G	420	420
3/4	19	G 1/2	13	35	21	19	55	71	23.8	50.8	10.6	0.58	PFF63G12	420	420
1	25	G 1	25	44	24	20	69	81	27.8	57.2	13.3	0.86	PFF64G	420	420
1	25	G 3/4	19	44	24	18	69	81	27.8	57.2	13.3	0.94	PFF64G34	420	420
1 1/4	32	G 1 1/4	31	44	27	22	79	95	31.8	66.7	15.0**	1.16	PFF65G	420	420
1 1/4	32	G 1 1/4	32	45	27	25	78	95	31.8	66.7	13.5	1.23	PFF65/12G	420	420
1 1/4	32	G 1	25	45	27	24	78	95	31.8	66.7	15.0**	1.26	PFF65G1	420	420
1 1/4	32	G 1	25	45	27	25	78	95	31.8	66.7	13.3	1.26	PFF65/12G1	420	420
1 1/2	38	G 1 1/2	38	51	30	24	88	107	36.5	79.4	16.7	1.98	PFF66G	420	420
1 1/2	38	G 1 1/4	32	50	30	25	95	114	36.5	79.4	16.7	2.08	PFF66G114	420	420
2	51	G 2	50	70	37	33	117	136	44.5	96.8	20.6	3.31	PFF68G	420	420
2	51	G 1 1/2	38	65	37	28	114	134	44.5	96.8	20.6	3.76	PFF68G112	420	420
2 1/2	64	G 2 1/2	63	80	45	32	152	180	58.7	123.8	25.0	3.05	PFF610G	420	420
3	76	G 3	73	90	55	40	178	208	71.4	152.4	32.0	3.45	PFF612G	420	420

*Please add the suffixes below according to the material/surface required.

Order code suffixes					
Material	Suffix surface and material	Example only 4 bolt flange	Example 4 bolt flange incl. metr. bolts and O-ring	Example 4 bolt flange incl. UNC bolts and O-ring	Standard sealing material (no additional suffix needed)
Steel, zinc plated, Cr(VI)-free	CF	PFF32G38CF	PFF32G38CFM	PFF32G38CFU	NBR
Stainless steel	SS	PFF32G38SS	PFF32G38SSM	-	VIT

** DB = 13.3 for UNC Bolts

*** = 12 for UNC Bolts

1) Pressure shown = Item deliverable

$$\frac{PN \text{ (bar)}}{10} = PN \text{ (MPa)}$$

Stainless steel parts may have dimensional deviations. Additional information on request.

PCFF-G SAE Straight 4 bolt flange with BSPP thread

SAE Counter flange / Female BSPP thread
(ISO 6162-1/-2)

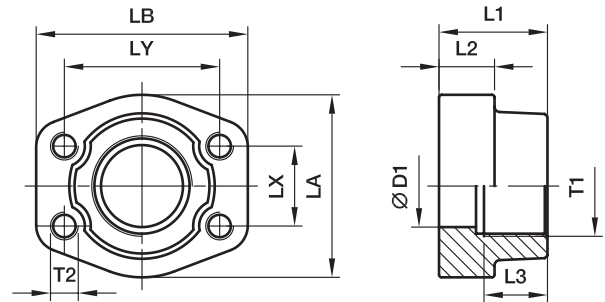

3000 PSI Series

Nom. flange size		T1	D1	L1	L2	L3	LA	LB	LX	LY	T2		Weight (steel) kg/piece	Order code*	PN (bar ¹)	
SAE (in.)	ISO (DN)										(metr.)	(unc.)			S	SS
1/2	13	G 3/8	13	36	16	15.0	46	57	17.5	38.1	M 8	5/16	0.33	PCFF32G38	345	345
1/2	13	G 1/2	13	36	16	18.0	46	54	17.5	38.1	M 8	5/16	0.29	PCFF32G	345	345
3/4	19	G 3/4	19	36	18	19.0	52	65	22.3	47.6	M10	3/8	0.34	PCFF33G	345	345
3/4	19	G 1/2	13	36	18	19.0	50	65	22.3	47.6	M10	3/8	0.42	PCFF33G12	345	345
1	25	G 1	25	38	18	20.5	59	70	26.2	52.4	M10	3/8	0.47	PCFF34G	345	345
1	25	G 3/4	19	35	21	19.0	55	70	26.2	52.4	M10	3/8	0.56	PCFF34G34	345	345
1 1/4	32	G 1 1/4	32	40	21	22.0	68	79	30.2	58.7	M10	7/16	0.68	PCFF35G	276	276
1 1/4	32	G 1	25	42	25	22.0	65	80	30.2	58.7	M10	7/16	0.84	PCFF35G1	276	276
1 1/2	38	G 1 1/2	38	45	25	24.0	78	93	35.7	69.9	M12	1/2	1.12	PCFF36G	207	207
1 1/2	38	G 1 1/4	32	45	27	22.0	78	95	35.7	69.9	M12	1/2	1.22	PCFF36G114	207	207
2	51	G 2	50	45	25	26.0	89	103	42.9	77.8	M12	1/2	1.38	PCFF38G	207	207
2	51	G 1 1/2	38	45	25	24.0	89	103	42.9	77.8	M12	1/2	1.59	PCFF38G112	207	207
2 1/2	64	G 2 1/2	63	50	25	30.0	101	115	50.8	88.9	M12	1/2	1.66	PCFF310G	172	172
2 1/2	64	G 2	51	50	25	30.0	101	115	50.8	88.9	M12	1/2	2.09	PCFF310G2	172	172
3	76	G 3	73	50	27	30.0	124	135	61.9	106.4	M16	5/8	2.37	PCFF312G	138	138
3	76	G 2 1/2	63	50	27	30.0	124	135	61.9	106.4	M16	5/8	2.65	PCFF312G212	138	138
3 1/2	89	G 3 1/2	89	50	27	30.0	136	152	69.9	120.7	M16	5/8	2.51	PCFF314G	34	34
3 1/2	89	G 3	73	48	27	34.0	136	152	69.9	120.7	M16	5/8	3.37	PCFF314G3	34	34
4	102	G 4	99	50	27	30.0	146	162	77.8	130.2	M16	5/8	2.87	PCFF316G	34	34
4	102	G 3 1/2	89	48	27	34.0	146	162	77.8	130.2	M16	5/8	3.39	PCFF316G312	34	34
5	127	G 5	120	50	28	30.0	180	184	92.1	152.4	M16	5/8	5.80	PCFF320G	34	34

6000 PSI Series

1/2	13	G 3/8	13	36	16	13.0	46	57	18.2	40.5	M 8	5/16	0.33	PCFF62G38	420	420
1/2	13	G 1/2	13	36	16	19.0	46	57	18.2	40.5	M 8	5/16	0.29	PCFF62G	420	420
3/4	19	G 3/4	19	35	21	22.0	55	71	23.8	50.8	M10	3/8	0.58	PCFF63G	420	420
3/4	19	G 1/2	13	35	21	19.0	55	71	23.8	50.8	M10	3/8	0.58	PCFF63G12	420	420
1	25	G 1	25	42	25	24.0	65	81	27.8	57.2	M12	7/16	0.82	PCFF64G	420	420
1	25	G 3/4	19	42	25	22.0	65	81	27.8	57.2	M12	7/16	0.88	PCFF64G34	420	420
1 1/4	32	G 1 1/4	32	45	27	25.0	78	95	31.8	66.6	M14	1/2	1.18	PCFF65G	420	420
1 1/4	32	G 1 1/4	32	45	27	25.0	78	95	31.8	66.6	M12	-	1.18	PCFF65/12G	420	420
1 1/4	32	G 1	25	45	27	24.0	78	95	31.8	66.6	M14	1/2	1.24	PCFF65G1	420	420
1 1/4	32	G 1	25	45	27	24.0	78	95	31.8	66.6	M12	-	1.24	PCFF65/12G1	420	420
1 1/2	38	G 1 1/2	38	50	30	28.0	94	112	36.5	79.3	M16	5/8	1.90	PCFF66G	420	420
1 1/2	38	G 1 1/4	32	50	30	25.0	94	112	36.5	79.3	M16	5/8	2.03	PCFF66G114	420	420
2	51	G 2	50	70	37	33.0	116	135	44.5	96.8	M20	3/4	3.68	PCFF68G	420	420
2	51	G 1 1/2	38	65	37	28.0	114	134	44.5	96.8	M20	3/4	3.86	PCFF68G112	420	420
2 1/2	64	G 2 1/2	63	80	45	32.0	152	180	58.7	123.8	M24	-	6.98	PCFF610G	420	420
3	76	G 3	73	90	55	40.0	178	208	71.4	152.4	M30	-	13.00	PCFF612G	420	420

*Please add the suffixes below according to the material/surface required.

Order code suffixes				
Material	Suffix surface and material	Example 4 bolt flange with metr. threads	Example 4 bolt flange with UNC threads	Standard sealing material (no additional suffix needed)
Steel, zinc plated, Cr(VI)-free	CF	PCFF32G38CFM	PCFF32G38CFU	NBR
Stainless steel	SS	PCFF32G38SSM	PCFF32G38SSU	VIT

¹) Pressure shown = Item deliverable

$$\frac{PN \text{ (bar)}}{10} = PN \text{ (MPa)}$$

Stainless steel parts may have dimensional deviations. Additional information on request.

PAFSF-G SAE Straight 4 bolt flange flat with BSPP thread

SAE Flange / Female BSPP thread
(ISO 6162-1/-2)

only for low pressure applications

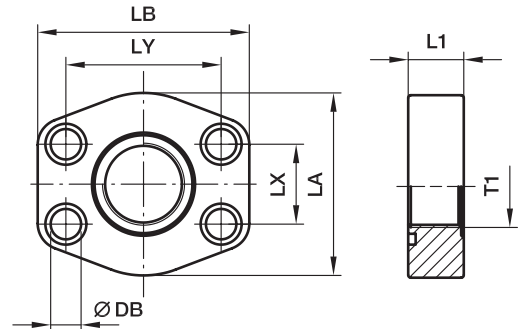

3000 PSI Series

Nom. flange size		T1	L1	LA	LB	LX	LY	DB	Bolts		O-ring	Weight (steel) kg/piece	Order code*	PN (bar) ¹⁾	
SAE (in.)	ISO (DN)								(metr.)	(unc.)				S	SS
1/2	13	G 3/8	16	46	58	17.5	38.1	8.9	M 08x30	5/16x1 1/4	Standard	0.20	PAFSF080G38	40	40
1/2	13	G 1/2	16	46	58	17.5	38.1	8.9	M 08x30	5/16x1 1/4	OR25.07x2.62X	0.27	PAFSF080G	40	40
3/4	19	G 1/2	18	49	66	22.3	47.6	10.6	M 10x35	3/8x1 1/2	Standard	0.29	PAFSF100G12	40	40
3/4	19	G 3/4	18	49	66	22.3	47.6	10.6	M 10x35	3/8x1 1/2	OR31.34X3.53X	0.27	PAFSF100G	40	40
1	25	G 3/4	19	53	71	26.2	52.4	10.6	M 10x35	3/8x1 1/2	Standard	0.37	PAFSF102G34	40	40
1	25	G 1	19	53	71	26.2	52.4	10.6	M 10x35	3/8x1 1/2	OR37.7X3.53X	0.32	PAFSF102G	40	40
1 1/4	32	G 1	21	69	80	30.2	58.7	10.6***	M 10x35	7/16x1 1/2	Standard	0.57	PAFSF104G1	40	40
1 1/4	32	G 1 1/4	21	69	80	30.2	58.7	10.6***	M 10x35	7/16x1 1/2	OR44.45X3.53X	0.62	PAFSF104G	40	40
1 1/2	38	G 1 1/4	24	77	95	35.7	69.9	13.3	M 12x45	1/2x1 3/4	Standard	0.83	PAFSF106G114	40	40
1 1/2	38	G 1 1/2	24	77	95	35.7	69.9	13.3	M 12x45	1/2x1 3/4	OR52.39X3.53X	0.79	PAFSF106G	40	40
2	51	G 1 1/2	24	89	103	42.9	77.8	13.5	M 12x45	1/2x1 3/4	Standard	1.00	PAFSF108G112	40	40
2	51	G 2	24	89	103	42.9	77.8	13.5	M 12x45	1/2x1 3/4	OR65.09X3.53X	0.90	PAFSF108G	40	40
2 1/2	64	G 2	25	101	116	50.8	88.9	13.5	M 12x45	1/2x1 3/4	Standard	1.30	PAFSF110G2	40	40
2 1/2	64	G 2 1/2	25	101	116	50.8	88.9	13.5	M 12x45	1/2x1 3/4	OR78.97X3.53X	1.25	PAFSF110G	40	40
3	76	G 2 1/2	25	124	136	61.9	106.4	16.7	M 16x55	5/8x2 1/4	Standard	1.86	PAFSF112G212	30	30
3	76	G 3	25	124	136	61.9	106.4	16.7	M 16x55	5/8x2 1/4	OR94.84X3.53X	1.49	PAFSF112G	30	30
3 1/2	89	G 3	25	136	152	69.9	120.7	16.7	M 16x55	5/8x2 1/4	Standard	1.68	PAFSF114G3	30	30
3 1/2	89	G 3 1/2	25	136	152	69.9	120.7	16.7	M 16x55	5/8x2 1/4	OR107.5X3.53X	1.59	PAFSF114G	30	30
4	102	G 3 1/2	25	146	162	77.8	130.2	16.7	M 16x55	5/8x2 1/4	Standard	2.35	PAFSF116G312	30	30
4	102	G 4	25	146	162	77.8	130.2	16.7	M 16x55	5/8x2 1/4	OR117.1X3.53X	2.25	PAFSF116G	30	30
5	127	G 4	25	180	184	92.1	152.4	16.7	M 16x55	5/8x2 1/4	Standard	3.45	PAFSF118G4	30	30
5	127	G 5	25	180	184	92.1	152.4	16.7	M 16x55	5/8x2 1/4	OR145.6X3.53X	3.15	PAFSF118G	30	30

6000 PSI Series

1/2	13	G 3/8	16	46	58	18.2	40.5	8.9	M 08x30	5/16x1 1/4	Standard	0.25	PAFSF401G38	40	40
1/2	13	G 1/2	16	46	58	18.2	40.5	8.9	M 08x30	5/16x1 1/4	OR25.07X2.62X	0.20	PAFSF401G	40	40
3/4	19	G 1/2	19	53	71	23.8	50.8	10.6	M 10x35	3/8x1 1/2	Standard	0.37	PAFSF402G12	40	40
3/4	19	G 3/4	19	60	71	23.8	50.8	10.6	M 10x35	3/8x1 1/2	OR32.92X3.53X	0.36	PAFSF402G	40	40
1	25	G 3/4	24	66	80	27.8	57.2	13.3***	M 12x45	7/16x1 1/2	Standard	0.64	PAFSF403G34	40	40
1	25	G 1	24	66	80	27.8	57.2	13.3***	M 12x45	7/16x1 1/2	OR37.7X3.53X	0.60	PAFSF403G	40	40
1 1/4	32	G 1	27	77	94	31.8	66.6	15.0**	M 14x50	1/2x1 3/4	Standard	0.88	PAFSF404G1	40	40
1 1/4	32	G 1	27	77	94	31.8	66.6	13.3	M 12x50	-	Standard	0.88	PAFSF404/12G1	40	40
1 1/4	32	G 1 1/4	27	77	94	31.8	66.6	15.0**	M 14x50	1/2x1 3/4	OR44.45X3.53X	0.87	PAFSF404G	40	40
1 1/4	32	G 1 1/4	27	77	94	31.8	66.6	13.3	M 12x50	-	OR44.45X3.53X	0.87	PAFSF404/12G	40	40
1 1/2	38	G 1 1/4	30	89	103	36.5	79.3	16.7	M 16x55	5/8x2 1/4	Standard	1.14	PAFSF405G114	40	40
1 1/2	38	G 1 1/2	30	89	103	36.5	79.3	16.7	M 16x55	5/8x2 1/4	OR52.39X3.53X	1.01	PAFSF405G	40	40
2	51	G 1 1/2	35	123	135	44.5	96.8	20.6	M 20x70	3/4x2 3/4	Standard	2.94	PAFSF406G112	40	40
2	51	G 2	35	123	135	44.5	96.8	20.6	M 20x70	3/4x2 3/4	OR65.09X3.53X	2.84	PAFSF406G	40	40

*Please add the suffixes below according to the material/surface required.

Order code suffixes					
Material	Suffix surface and material	Example only 4 bolt flange	Example 4 bolt flange incl. metr. bolts and O-ring	Example 4 bolt flange incl. UNC bolts and O-ring	Standard sealing material (no additional suffix needed)
Steel, zinc plated, Cr(VI)-free	CF	PAFSF080GCF	PAFSF080GCFM	PAFSF080GCFU	NBR
Stainless steel	SS	PAFSF080GSS	PAFSF080GSSM	-	VIT

** DB = 13.3 for UNC Bolts

*** = 12 for UNC Bolts

¹⁾ Pressure shown = Item deliverable

$$\frac{PN \text{ (bar)}}{10} = PN \text{ (MPa)}$$

Stainless steel parts may have dimensional deviations. Additional information on request.

PEFF-G SAE 90° 4 bolt flange with BSPP thread

SAE 90° Flange / Female BSPP thread
(ISO 6162-1/-2)

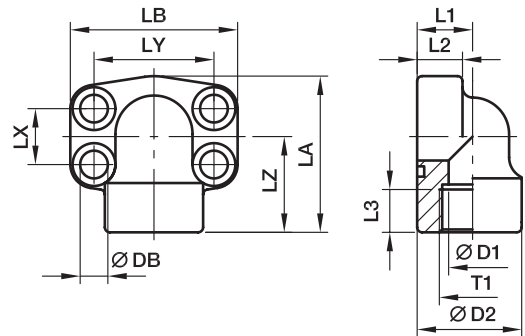

3000 PSI Series

Nom. flange size		T1	D1	D2	L1	L2	L3	LA	LB	LX	LY	LZ	DB	Bolt		Weight (steel) kg/piece	Order code*	PN (bar) ¹⁾	
SAE (in.)	ISO (DN)													(metr.)	(unc.)			S	SS
1/2	13	G 1/2	13	34.0	18	16	16	59	57	17.5	38.1	36	8.9	M 08×30	5/16×1 1/4	0.33	PEFF32G	348	348
3/4	19	G 3/4	19	38.5	22	18	19	63	68	22.3	47.6	38	10.6	M 10×35	3/8×1 1/2	0.52	PEFF33G	348	348
1	25	G 1	25	44.5	28	19	19	68	72	26.2	52.4	41	10.6	M 10×35	3/8×1 1/2	0.64	PEFF34G	348	348
1 1/4	32	G 1 1/4	31	53.5	30	22	22	84	81	30.2	58.7	50	10.6***	M 10×35	7/16×1 1/2	0.99	PEFF35G	278	278
1 1/2	38	G 1 1/2	38	62.5	36	25	24	97	93	35.7	69.9	58	13.3	M 12×45	1/2×1 3/4	1.42	PEFF36G	210	210
2	51	G 2	50	77.0	41	25	26	109	105	42.9	77.8	65	13.5	M 12×45	1/2×1 3/4	2.00	PEFF38G	210	210
2 1/2	64	G 2 1/2	60	89.0	50	25	30	127	115	50.8	88.9	77	13.5	M 12×45	1/2×1 3/4	2.90	PEFF310G	175	175

6000 PSI Series

1/2	13	G 1/2	13	34.0	18	16	16	59	57	18.2	40.5	36	8.9	M 08×30	5/16×1 1/4	0.33	PEFF62G	420	420
3/4	19	G 3/4	19	44.5	28	20	22	68	72	23.8	50.8	41	10.6	M 10×35	3/8×1 1/2	0.80	PEFF63G	420	420
1	25	G 1	25	53.5	30	24	24	84	82	27.8	57.2	50	13.3***	M 12×45	7/16×1 1/2	1.16	PEFF64G	420	420
1 1/4	32	G 1 1/4	31	62.5	36	25	25	97	95	31.8	66.6	58	15.0**	M 14×50	1/2×1 3/4	1.66	PEFF65G	420	420
1 1/4	32	G 1 1/4	31	62.5	36	25	25	97	95	31.8	66.6	58	13.3	M 12×50	-	1.66	PEFF65/12G	420	420
1 1/2	38	G 1 1/2	38	62.0	41	26	23	109	105	36.5	79.3	65	16.7	M 16×55	5/8×2 1/4	2.24	PEFF66G	420	420
2	51	G 2	50	87.0	45	35	34	133	134	44.5	96.8	75	20.6	M 20×70	3/4×2 3/4	3.85	PEFF68G	420	420

**DB = 13.3 for UNC Bolts

***DB = 12 for UNC Bolts

1) Pressure shown = Item deliverable

PN (bar) / 10 = PN (MPa)

Stainless steel parts may have dimensional deviations. Additional information on request.

*Please add the **suffixes** below according to the material/surface required.

Order code suffixes					
Material	Suffix surface and material	Example only 4 bolt flange	Example 4 bolt flange incl. metr. bolts and O-ring	Example 4 bolt flange incl. UNC bolts and O-ring	Standard sealing material (no additional suffix needed)
Steel, zinc plated, Cr(VI)-free	CF	PEFF32GCF	PEFF32GCFM	PEFF32GCFU	NBR
Stainless steel	SS	PEFF32GSS	PEFF32GSSM	-	VIT

PFF-N SAE Straight 4 bolt flange with NPT thread

SAE Flange / Female NPT thread
(ISO 6162-1/-2) (SAE 476)

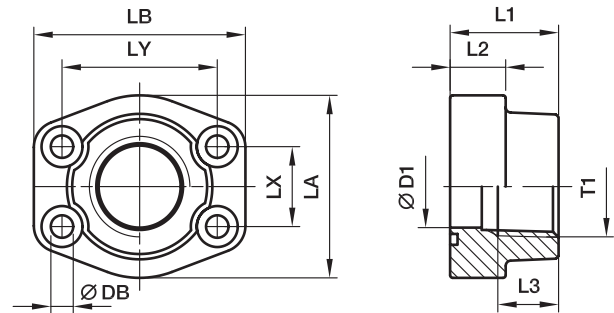

3000 PSI Series

Nom. flange size		T1	D1	L1	L2	L3	LA	LB	LX	LY	DB	Bolts		Weight (steel) kg/piece	Order code*	PN (bar ¹⁾)	
SAE (in.)	ISO (DN)											(metr.)	(unc.)			S	SS
1/2	13	3/8 NPT	13	36	16	15	46	58	17.5	38.1	8.9	M 08x30	5/16x1 1/4	0.25	PFF32N38	345	345
1/2	13	1/2 NPT	13	36	16	15	46	58	17.5	38.1	8.9	M 08x30	5/16x1 1/4	0.28	PFF32N	345	345
3/4	19	3/4 NPT	19	36	18	19	49	66	22.3	47.6	10.6	M 10x35	3/8x1 1/2	0.39	PFF33N	345	345
1	25	1 NPT	25	38	18	19	53	71	26.2	52.4	10.6	M 10x35	3/8x1 1/2	0.46	PFF34N	345	345
1 1/4	32	1 1/4 NPT	31	41	21	22	69	80	30.2	58.7	10.6***	M 10x40	7/16x1 1/2	0.66	PFF35N	276	276
1 1/2	38	1 1/2 NPT	38	44	25	24	77	94	35.7	69.9	13.3	M 12x45	1/2x1 3/4	1.05	PFF36N	207	207
2	51	2 NPT	50	45	25	26	89	103	42.9	77.8	13.5	M 12x45	1/2x1 3/4	1.19	PFF38N	207	207
2 1/2	64	2 1/2 NPT	63	50	25	30	101	115	50.8	88.9	13.5	M 12x45	1/2x1 3/4	1.70	PFF310N	172	172
3	76	3 NPT	73	50	27	34	124	135	61.9	106.4	16.7	M 16x55	5/8x2 1/4	2.22	PFF312N	138	138
3 1/2	89	3 1/2 NPT	89	50	27	36	136	152	69.9	120.7	16.7	M 16x55	5/8x2 1/4	2.40	PFF314N	34	34
4	102	4 NPT	99	50	27	36	146	162	77.8	130.2	16.7	M 16x55	5/8x2 1/4	2.71	PFF316N	34	34
5	127	5 NPT	120	50	28	36	180	184	92.1	152.4	16.7	M 16x55	5/8x2 1/4	3.25	PFF320N	34	34

6000 PSI Series

1/2	13	3/8 NPT	13	36	16	15	46	58	18.2	40.5	8.9	M 08x30	5/16x1 1/4	0.26	PFF62N38	420	420
1/2	13	1/2 NPT	13	36	16	15	46	58	18.2	40.5	8.9	M 08x30	5/16x1 1/4	0.29	PFF62N	420	420
3/4	19	3/4 NPT	19	36	19	22	53	71	23.8	50.8	10.6	M 10x35	3/8x1 1/2	0.50	PFF63N	420	420
1	25	1 NPT	25	44	24	24	69	80	27.8	57.2	13.3***	M 12x45	7/16x1 1/2	0.76	PFF64N	420	420
1 1/4	32	1 1/4 NPT	31	44	27	25	77	94	31.8	66.6	15.0**	M 14x50	1/2x1 3/4	1.20	PFF65N	420	420
1 1/4	32	1 1/4 NPT	31	44	27	25	77	94	31.8	66.6	13.3	M 12x50	-	1.20	PFF65/12N	420	420
1 1/2	38	1 1/2 NPT	38	51	30	24	89	106	36.5	79.3	16.7	M 16x55	5/8x2 1/4	1.91	PFF66N	420	420
2	51	2 NPT	50	70	37	33	116	135	44.5	96.8	20.6	M 20x70	3/4x2 3/4	3.37	PFF68N	420	420
2 1/2	64	2 1/2 NPT	63	75	45	35	150	166	58.7	123.8	25.0	M 24x90	-	3.05	PFF610N	420	420
3	76	3 NPT	73	90	55	40	178	208	71.4	152.4	31.0	M 30x110	-	3.45	PFF612N	420	420

**DB = 13.3 for UNC Bolts

***DB = 12 for UNC Bolts

1) Pressure shown = Item deliverable

$\frac{PN \text{ (bar)}}{10} = PN \text{ (MPa)}$

Stainless steel parts may have dimensional deviations. Additional information on request.

*Please add the suffixes below according to the material/surface required.

Order code suffixes					
Material	Suffix surface and material	Example only 4 bolt flange	Example 4 bolt flange incl. metr. bolts and O-ring	Example 4 bolt flange incl. UNC bolts and O-ring	Standard sealing material (no additional suffix needed)
Steel, oil dipped	S	PFF32N38S	PFF32N38SM	PFF32N38SU	NBR
Stainless steel	SS	PFF32N38SS	PFF32N38SSM	-	VIT

PCFF-N SAE Straight 4 bolt flange with NPT thread

SAE Counter flange / Female NPT thread
(ISO 6162-1/-2) (SAE 476)

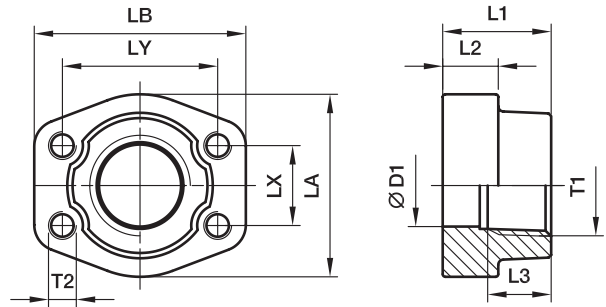

3000 PSI Series

Nom. flange size		T1	D1	L1	L2	L3	LA	LB	LX	LY	T2		Weight (steel) kg/piece	Order code*	PN (bar ¹⁾)	
SAE (in.)	ISO (DN)										(metr.)	(unc.)			S	SS
1/2	13	3/8 NPT	13	36	16	19	47	57	17.5	38.1	M 8	5/16	0.25	PCFF32N38	345	345
1/2	13	1/2 NPT	13	36	16	19	47	57	17.5	38.1	M 8	5/16	0.28	PCFF32N	345	345
3/4	19	3/4 NPT	19	36	18	19	49	66	22.3	47.6	M10	3/8	0.44	PCFF33N	345	345
1	25	1 NPT	25	38	18	19	53	71	26.2	52.4	M10	3/8	0.53	PCFF34N	345	345
1 1/4	32	1 1/4 NPT	31	41	21	22	69	80	30.2	58.7	M10	7/16	0.66	PCFF35N	276	276
1 1/2	38	1 1/2 NPT	38	44	25	24	77	94	35.7	69.9	M12	1/2	1.05	PCFF36N	207	207
2	51	2 NPT	50	45	25	26	89	103	42.9	77.8	M12	1/2	1.19	PCFF38N	207	207
2 1/2	64	2 1/2 NPT	63	50	25	30	101	115	50.8	88.9	M12	1/2	1.40	PCFF310N	172	172
3	76	3 NPT	73	50	27	30	124	135	61.9	106.4	M16	5/8	2.15	PCFF312N	138	138
3 1/2	89	3 1/2 NPT	89	50	27	30	136	152	69.9	120.7	M16	5/8	2.40	PCFF314N	34	34
4	102	4 NPT	99	50	27	30	146	162	77.8	130.2	M16	5/8	2.85	PCFF316N	34	34
5	127	5 NPT	120	50	28	30	180	184	92.1	152.4	M16	5/8	3.25	PCFF320N	34	34

6000 PSI Series

1/2	13	3/8 NPT	13	36	16	19	47	57	18.2	40.5	M 8	5/16	0.26	PCFF62N38	420	420
1/2	13	1/2 NPT	13	36	16	19	47	57	18.2	40.5	M 8	5/16	0.29	PCFF62N	420	420
3/4	19	3/4 NPT	19	36	19	22	53	71	23.8	50.8	M10	3/8	0.50	PCFF63N	420	420
1	25	1 NPT	25	44	24	24	69	80	27.8	57.2	M12	7/16	0.76	PCFF64N	420	420
1 1/4	32	1 1/4 NPT	31	44	27	25	77	94	31.8	66.6	M14	1/2	1.20	PCFF65N	420	420
1 1/4	32	1 1/4 NPT	31	44	27	25	77	94	31.8	66.6	M12	-	1.20	PCFF65/12N	420	420
1 1/2	38	1 1/2 NPT	38	51	30	28	89	106	36.5	79.3	M16	5/8	1.65	PCFF66N	420	420
2	51	2 NPT	50	70	37	33	116	135	44.5	96.8	M20	3/4	2.45	PCFF68N	420	420
2 1/2	64	2 1/2 NPT	63	75	45	35	150	166	58.7	123.8	M24	-	3.05	PCFF610N	420	420
3	76	3 NPT	73	90	55	40	178	208	71.4	152.4	M30	-	3.45	PCFF612N	420	420

¹⁾ Pressure shown = Item deliverable

$$\frac{PN \text{ (bar)}}{10} = PN \text{ (MPa)}$$

Stainless steel parts may have dimensional deviations. Additional information on request.

*Please add the **suffixes** below according to the material/surface required.

Order code suffixes				
Material	Suffix surface and material	Example 4 bolt flange with metr. threads	Example 4 bolt flange with UNC threads	Standard sealing material (no additional suffix needed)
Steel, oil dipped	S	PCFF32N38SM	PCFF32N38SU	NBR
Stainless steel	SS	PCFF32N38SSM	PCFF32N38SSU	VIT

SAE Full flanges

PEFF-N SAE 90° 4 bolt flange with NPT thread

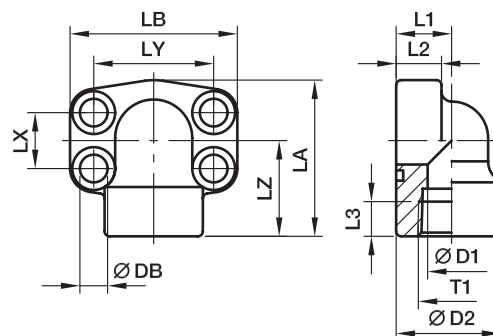
 SAE 90° Flange / Female NPT thread
 (ISO 6162-1/-2) (SAE 476)

3000 PSI Series

Nom. flange size		T1	D1	D2	L1	L2	L3	LA	LB	LX	LY	LZ	DB	Bolts		Weight (steel) kg/piece	Order code*	PN (bar) ¹⁾	
SAE (in.)	ISO (DN)													(metr.)	(unc.)			S	SS
1/2	13	1/2 NPT	13	34.0	18	16	16	59	56	17.5	38.1	36	8.9	M 08×30	5/16×1 1/4	0.35	PEFF32N	348	348
3/4	19	3/4 NPT	19	38.5	22	18	19	63	68	22.3	47.6	38	10.6	M 10×35	3/8×1 1/2	0.55	PEFF33N	348	348
1	25	1 NPT	25	44.5	28	19	19	68	74	26.2	52.4	41	10.6	M 10×35	3/8×1 1/2	0.80	PEFF34N	348	348
1 1/4	32	1 1/4 NPT	31	53.5	30	22	22	84	81	30.2	58.7	50	10.6***	M 10×35	7/16×1 1/2	1.30	PEFF35N	278	278
1 1/2	38	1 1/2 NPT	38	62.5	36	25	24	97	95	35.7	69.9	58	13.3	M 12×45	1/2×1 3/4	1.60	PEFF36N	210	210
2	51	2 NPT	50	77.0	41	25	26	109	105	42.9	77.8	65	13.5	M 12×45	1/2×1 3/4	2.00	PEFF38N	210	210
2 1/2	64	2 1/2 NPT	60	89.0	50	25	30	127	115	50.8	88.9	77	13.5	M 12×45	1/2×1 3/4	2.40	PEFF310N	175	175

6000 PSI Series

1/2	13	1/2 NPT	13	34.0	18	16	16	59	56	18.2	40.5	36	8.9	M 08×30	5/16×1 1/4	0.35	PEFF62N	420	420
3/4	19	3/4 NPT	19	44.5	28	20	22	68	72	23.8	50.8	41	10.6	M 10×35	3/8×1 1/2	0.80	PEFF63N	420	420
1	25	1 NPT	25	53.5	30	24	24	84	82	27.8	57.2	50	13.3***	M 12×45	7/16×1 1/2	1.30	PEFF64N	420	420
1 1/4	32	1 1/4 NPT	31	62.5	36	25	25	97	95	31.8	66.6	58	15.0**	M 14×50	1/2×1 3/4	1.60	PEFF65N	420	420
1 1/4	32	1 1/4 NPT	31	62.5	36	25	25	97	95	31.8	66.6	58	13.3	M 12×50	–	1.60	PEFF65/12N	420	420
1 1/2	38	1 1/2 NPT	38	77.0	51	26	28	109	110	36.5	79.3	65	16.7	M 16×55	5/8×2 1/4	2.00	PEFF66N	420	420
2	51	2 NPT	50	87.0	45	35	34	133	134	44.5	96.8	75	20.6	M 20×70	3/4×2 3/4	2.50	PEFF68N	420	420

**DB = 13.3 for UNC Bolts

***DB = 12 for UNC Bolts

1) Pressure shown = Item deliverable

$$\frac{\text{PN (bar)}}{10} = \text{PN (MPa)}$$

Stainless steel parts may have dimensional deviations. Additional information on request.

 *Please add the **suffixes** below according to the material/surface required.

Order code suffixes					
Material	Suffix surface and material	Example only 4 bolt flange	Example 4 bolt flange incl. metr. bolts and O-ring	Example 4 bolt flange incl. UNC bolts and O-ring	Standard sealing material (no additional suffix needed)
Steel, oil dipped	S	PEFF32NS	PEFF32NSM	PEFF32NSU	NBR
Stainless steel	SS	PEFF32NSS	PEFF32NSSM	–	VIT

PFF-..S/L SAE Straight 4 bolt flange with EO 24° cone end

SAE Flange / EO 24° cone end
(ISO 6162-1/-2)

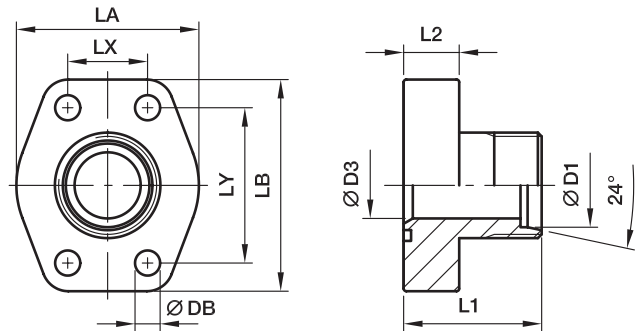

3000 PSI Series

Nom. flange size	D1 ²⁾	D3	L1	L2	LA	LB	LX	LY	DB	Bolts		Weight (steel) kg/piece	Order code*	PN (bar) ¹⁾		
										(metr.)	(unc.)			CF	SS	
1/2	13	12S	8	47	16	42	57	17.5	38.1	8.9	M 08x30	5/16x1 1/4	0.27	PFF32/12S	348	348
1/2	13	15L	11	47	16	42	57	17.5	38.1	8.9	M 08x30	5/16x1 1/4	0.27	PFF32/15L	348	315
1/2	13	16S	12	47	16	42	57	17.5	38.1	8.9	M 08x30	5/16x1 1/4	0.27	PFF32/16S	348	348
3/4	19	16S	12	52	18	50	66	22.3	47.6	10.6	M 10x35	3/8x1 1/2	0.42	PFF33/16S	348	348
3/4	19	20S	16	52	18	50	66	22.3	47.6	10.6	M 10x35	3/8x1 1/2	0.45	PFF33/20S	348	348
3/4	19	22L	18	52	18	50	66	22.3	47.6	10.6	M 10x35	3/8x1 1/2	0.44	PFF33/22L	250	160
1	25	20S	16	55	18	55	71	26.2	52.4	10.6	M 10x35	3/8x1 1/2	0.54	PFF34/20S	348	348
1	25	25S	20	55	18	55	71	26.2	52.4	10.6	M 10x35	3/8x1 1/2	0.55	PFF34/25S	348	348
1	25	28L	23	55	18	55	71	26.2	52.4	10.6	M 10x35	3/8x1 1/2	0.53	PFF34/28L	250	160
1 1/4	32	25S	20	60	21	66	80	30.2	58.7	10.6***	M 10x40	7/16x1 1/2	0.83	PFF35/25S	278	278
1 1/4	32	30S	25	60	21	66	80	30.2	58.7	10.6***	M 10x40	7/16x1 1/2	0.85	PFF35/30S	278	278
1 1/4	32	35L	30	60	21	66	80	30.2	58.7	10.6***	M 10x40	7/16x1 1/2	0.79	PFF35/35L	278	278
1 1/2	38	35L	30	70	25	77	94	35.7	69.9	13.3	M 12x45	1/2x1 3/4	1.25	PFF36/35L	210	210
1 1/2	38	38S	32	70	25	77	94	35.7	69.9	13.3	M 12x45	1/2x1 3/4	1.30	PFF36/38S	210	210
1 1/2	38	42L	36	70	25	77	94	35.7	69.9	13.3	M 12x45	1/2x1 3/4	1.21	PFF36/42L	210	210
2	51	38S	32	72	25	90	103	42.9	77.8	13.3	M 12x45	1/2x1 3/4	1.80	PFF38/38S	210	210
2	51	42L	36	72	25	90	103	42.9	77.8	13.3	M 12x45	1/2x1 3/4	1.60	PFF38/42L	210	210

6000 PSI Series

1/2	13	12S	8	47	16	47	57	18.2	40.5	8.9	M 08x30	5/16x1 1/4	0.27	PFF62/12S	420	420
1/2	13	14S	10	47	16	47	57	18.2	40.5	8.9	M 08x30	5/16x1 1/4	0.27	PFF62/14S	420	420
1/2	13	16S	12	47	16	47	57	18.2	40.5	8.9	M 08x30	5/16x1 1/4	0.27	PFF62/16S	420	420
3/4	19	16S	12	52	18	53	71	23.8	50.8	10.6	M 10x35	3/8x1 1/2	0.50	PFF63/16S	420	420
3/4	19	20S	16	52	18	53	71	23.8	50.8	10.6	M 10x35	3/8x1 1/2	0.51	PFF63/20S	420	400
3/4	19	22L	18	52	18	53	71	23.8	50.8	10.6	M 10x35	3/8x1 1/2	0.51	PFF63/22L	250	160
1	25	20S	16	60	21	66	80	27.8	57.2	13.3***	M 12x45	7/16x1 1/2	0.80	PFF64/20S	420	400
1	25	25S	20	60	21	66	80	27.8	57.2	13.3***	M 12x45	7/16x1 1/2	0.80	PFF64/25S	420	400
1	25	28L	23	60	21	66	80	27.8	57.2	13.3***	M 12x45	7/16x1 1/2	0.75	PFF64/28L	250	160
1 1/4	32	25S	20	68	24	78	94	31.8	66.6	15.0**	M 14x50	1/2x1 3/4	1.15	PFF65/25S	420	400
1 1/4	32	25S	20	68	24	78	94	31.8	66.6	13.3	M 12x50	-	1.15	PFF65/12/25S	420	400
1 1/4	32	30S	25	68	24	78	94	31.8	66.6	15.0**	M 14x50	1/2x1 3/4	1.18	PFF65/30S	420	400
1 1/4	32	30S	25	68	24	78	94	31.8	66.6	13.3	M 12x50	-	1.18	PFF65/12/30S	420	400
1 1/4	32	35L	30	68	24	78	94	31.8	66.6	15.0**	M 14x50	1/2x1 3/4	1.15	PFF65/35L	250	160
1 1/4	32	35L	30	68	24	78	94	31.8	66.6	13.3	M 12x50	-	1.15	PFF65/12/35L	250	160
1 1/4	32	38S	32	68	24	78	94	31.8	66.6	15.0**	M 14x50	1/2x1 3/4	1.28	PFF65/38S	420	315
1 1/4	32	38S	32	68	24	78	94	31.8	66.6	13.3	M 12x50	-	1.28	PFF65/12/38S	420	315
1 1/2	38	35L	25	72	27	90	106	36.5	79.3	16.7	M 16x55	5/8x2 1/4	1.60	PFF66/35L	250	160
1 1/2	38	38S	32	72	27	90	106	36.5	79.3	16.7	M 16x55	5/8x2 1/4	1.70	PFF66/38S	315	315
1 1/2	38	42L	36	72	27	90	106	36.5	79.3	16.7	M 16x55	5/8x2 1/4	1.60	PFF66/42L	250	160

²⁾ L = light series; S = heavy series

Delivery without nut and ring.

**DB = 13.3 for UNC Bolts

Information on ordering complete fittings

***DB = 12 for UNC Bolts

or alternative sealing materials see page N12.

Stainless steel parts may have dimensional deviations.

¹⁾ Pressure shown = Item deliverable

Additional information on request.

*Please add the suffixes below according to the material/surface required.

$$\frac{PN \text{ (bar)}}{10} = PN \text{ (MPa)}$$

Order code suffixes					
Material	Suffix surface and material	Example only 4 bolt flange	Example 4 bolt flange incl. metr. bolts and O-ring	Example 4 bolt flange incl. UNC bolts and O-ring	Standard sealing material (no additional suffix needed)
Steel, zinc plated, Cr(VI)-free	CF	PFF32/12SCF	PFF32/12SOMDCFM	PFF32/12SOMDCFU	NBR
Stainless steel	SS	PFF32/12S-SS	PFF32/12SOMDSSM	-	VIT

PAFG-90M SAE 90° 4 bolt flange with EO 24° cone end

SAE 90° Flange / EO 24° cone end
(ISO 6162-1/-2)

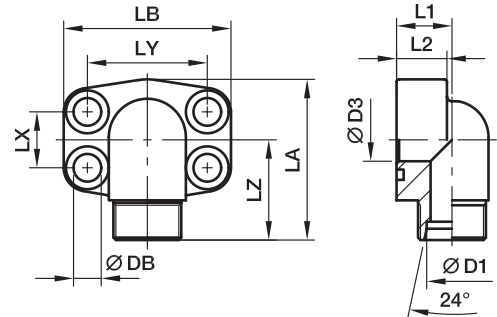

3000 PSI Series

Nom. flange size	D1 ²⁾	D3	L1	L2	LA	LB	LX	LY	LZ	DB	Bolts		Weight (steel) kg/piece	Order code*	PN (bar) ¹⁾		
											(metr.)	(unc.)			CF	SS	
1/2	13	12S	8	18	16	60	57	17.5	38.1	36	8.9	M 08×30	5/16×1 1/4	0.31	PAFG080/90M12S	348	348
1/2	13	15L	11	18	16	60	57	17.5	38.1	36	8.9	M 08×30	5/16×1 1/4	0.30	PAFG080/90M15L	348	315
1/2	13	16S	12	18	16	60	57	17.5	38.1	36	8.9	M 08×30	5/16×1 1/4	0.30	PAFG080/90M16S	348	348
3/4	19	16S	12	22	18	63	66	22.3	47.6	38	10.6	M 10×35	3/8×1 1/2	0.48	PAFG100/90M16S	348	348
3/4	19	20S	16	22	18	63	66	22.3	47.6	38	10.6	M 10×35	3/8×1 1/2	0.44	PAFG100/90M20S	348	348
3/4	19	22L	18	22	18	63	66	22.3	47.6	38	10.6	M 10×35	3/8×1 1/2	0.45	PAFG100/90M22L	250	160
1	25	20S	16	28	19	69	72	26.2	52.4	42	10.6	M 10×35	3/8×1 1/2	0.68	PAFG102/90M20S	348	348
1	25	25S	20	28	19	69	72	26.2	52.4	42	10.6	M 10×35	3/8×1 1/2	0.64	PAFG102/90M25S	348	348
1	25	28L	23	28	19	69	72	26.2	52.4	42	10.6	M 10×35	3/8×1 1/2	0.62	PAFG102/90M28L	250	160
1 1/4	32	25S	20	30	22	84	80	30.2	58.7	50	10.6***	M 10×40	7/16×1 1/2	1.05	PAFG104/90M25S	278	278
1 1/4	32	30S	25	30	22	84	80	30.2	58.7	50	10.6***	M 10×40	7/16×1 1/2	1.02	PAFG104/90M30S	278	278
1 1/4	32	35L	30	30	22	84	80	30.2	58.7	50	10.6***	M 10×40	7/16×1 1/2	0.94	PAFG104/90M35L	278	278
1 1/2	38	35L	30	36	25	88	94	35.7	69.9	58	13.3	M 12×45	1/2×1 3/4	1.51	PAFG106/90M35L	210	210
1 1/2	38	38S	32	36	25	88	94	35.7	69.9	58	13.3	M 12×45	1/2×1 3/4	1.55	PAFG106/90M38S	210	210
1 1/2	38	42L	36	36	25	88	94	35.7	69.9	58	13.3	M 12×45	1/2×1 3/4	1.42	PAFG106/90M42L	210	210

6000 PSI Series

1/2	13	12S	8	20	16	60	57	18.2	40.5	36	8.9	M 08×30	5/16×1 1/4	0.31	PAFG401/90M12S	420	420
1/2	13	14S	10	20	16	60	57	18.2	40.5	36	8.9	M 08×30	5/16×1 1/4	0.30	PAFG401/90M14S	420	420
1/2	13	16S	12	20	16	60	57	18.2	40.5	36	8.9	M 08×30	5/16×1 1/4	0.30	PAFG401/90M16S	420	420
3/4	19	16S	12	26	22	68	72	23.8	50.8	41	10.6	M 10×40	3/8×1 1/2	0.68	PAFG402/90M16S	420	420
3/4	19	20S	16	26	22	77	72	23.8	50.8	50	10.6	M 10×40	3/8×1 1/2	0.68	PAFG402/90M20S	420	400
3/4	19	22L	18	26	22	68	72	23.8	50.8	41	10.6	M 10×40	3/8×1 1/2	0.66	PAFG402/90M22L	250	160
1	25	20S	16	30	24	83	80	27.8	57.2	50	13.3***	M 12×45	7/16×1 1/2	1.11	PAFG403/90M20S	420	400
1	25	25S	20	30	24	83	80	27.8	57.2	50	13.3***	M 12×45	7/16×1 1/2	1.08	PAFG403/90M25S	420	400
1	25	28L	23	30	24	83	80	27.8	57.2	50	13.3***	M 12×45	7/16×1 1/2	1.05	PAFG403/90M28L	250	160
1 1/4	32	25S	20	36	25	97	94	31.8	66.6	58	15.0**	M 14×50	1/2×1 3/4	1.70	PAFG404/90M25S	420	400
1 1/4	32	25S	20	36	25	97	94	31.8	66.6	58	13.3	M 12×50	–	1.70	PAFG404/12/90M25S	420	400
1 1/4	32	30S	25	36	25	97	94	31.8	66.6	58	15.0**	M 14×50	1/2×1 3/4	1.45	PAFG404/90M30S	420	400
1 1/4	32	30S	25	36	25	97	94	31.8	66.6	58	13.3	M 12×50	–	1.45	PAFG404/12/90M30S	420	400
1 1/4	32	35L	30	36	25	97	94	31.8	66.6	58	15.0**	M 14×50	1/2×1 3/4	1.50	PAFG404/90M35L	250	160
1 1/4	32	35L	30	36	25	97	94	31.8	66.6	58	13.3	M 12×50	–	1.50	PAFG404/12/90M35L	250	160
1 1/2	38	35L	25	41	26	110	105	36.5	79.3	65	16.7	M 16×55	5/8×2 1/4	2.44	PAFG405/90M35L	250	160
1 1/2	38	38S	32/38	41	26	110	105	36.5	79.3	65	16.7	M 16×55	5/8×2 1/4	2.38	PAFG405/90M38S	315	315
1 1/2	38	42L	36	41	26	110	105	36.5	79.3	65	16.7	M 16×55	5/8×2 1/4	2.37	PAFG405/90M42L	250	160

²⁾ L = light series; S = heavy series

Delivery without nut and ring.
Information on ordering complete fittings
or alternative sealing materials see page N12.
Stainless steel parts may have dimensional deviations.
Additional information on request.

** DB = 13.3 for UNC Bolts
 ***DB = 12 for UNC Bolts
¹⁾ Pressure shown = Item deliverable

*Please add the **suffixes** below according to the material/surface required.

$$\frac{PN \text{ (bar)}}{10} = PN \text{ (MPa)}$$

Order code suffixes					
Material	Suffix surface and material	Example only 4 bolt flange	Example 4 bolt flange incl. metr. bolts and O-ring	Example 4 bolt flange incl. UNC bolts and O-ring	Standard sealing material (no additional suffix needed)
Steel, zinc plated, Cr(VI)-free	CF	PAFG080/90M12SCF	PAFG080/90M12SOMDCFM	PAFG080/90M12SOMDCFU	NBR
Stainless steel	SS	PAFG080/90M12S-SS	PAFG080/90M12SOMDSSM	–	VIT

PAFG-G SAE Straight 4 bolt flange with BSPP 60° cone end

SAE Flange / BSPP 60° cone end
(ISO 6162-1/-2) (ISO 8434-6)

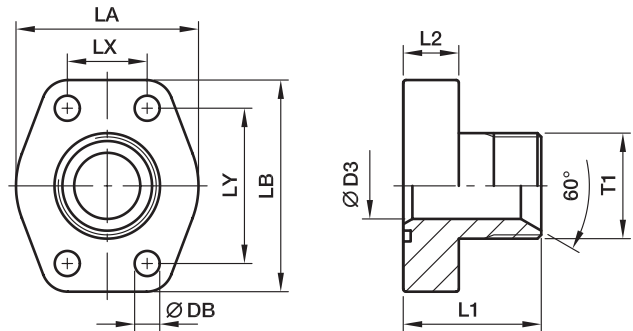

3000 PSI Series

Nom. flange size		T1	D3	L1	L2	LA	LB	LX	LY	DB	Bolts		Weight (steel) kg/piece	Order code*	PN (bar) ¹⁾	
SAE (in.)	ISO (DN)										(metr.)	(unc.)			CF	SS
1/2	13	G 3/8	10	37	16	47	56	17.5	38.1	8.9	M 08x30	5/16x1 1/4	0.25	PAFG080G38	348	348
1/2	13	G 1/2	12	39	16	47	56	17.5	38.1	8.9	M 08x30	5/16x1 1/4	0.29	PAFG080G	348	348
1/2	13	G 3/4	13	42	16	47	56	17.5	38.1	8.9	M 08x30	5/16x1 1/4	0.28	PAFG080G34	348	348
3/4	19	G 1/2	12	42	18	50	66	22.3	47.6	10.6	M 10x35	3/8x1 1/2	0.39	PAFG100G12	348	348
3/4	19	G 3/4	17	45	18	50	66	22.3	47.6	10.6	M 10x35	3/8x1 1/2	0.40	PAFG100G	348	348
3/4	19	G 1	19	47	18	50	66	22.3	47.6	10.6	M 10x35	3/8x1 1/2	0.43	PAFG100G1	348	348
1	25	G 3/4	17	47	18	53	71	26.2	52.4	10.6	M 10x35	3/8x1 1/2	0.44	PAFG102G34	348	348
1	25	G 1	22	49	18	53	71	26.2	52.4	10.6	M 10x35	3/8x1 1/2	0.49	PAFG102G	348	348
1	25	G 1 1/4	25	49	18	53	71	26.2	52.4	10.6	M 10x35	3/8x1 1/2	0.57	PAFG102G114	348	348
1 1/4	32	G 1	22	53	21	69	80	30.2	58.7	10.6***	M 10x40	7/16x1 1/2	0.74	PAFG104G1	278	278
1 1/4	32	G 1 1/4	27	53	21	69	80	30.2	58.7	10.6***	M 10x40	7/16x1 1/2	0.73	PAFG104G	278	278
1 1/4	32	G 1 1/2	31	55	21	69	80	30.2	58.7	10.6***	M 10x40	7/16x1 1/2	0.90	PAFG104G112	278	278
1 1/2	38	G 1 1/4	27	59	24	77	94	35.7	69.9	13.3	M 12x45	1/2x1 3/4	1.12	PAFG106G114	210	210
1 1/2	38	G 1 1/2	34	61	24	77	94	35.7	69.9	13.3	M 12x45	1/2x1 3/4	1.10	PAFG106G	210	210
1 1/2	38	G 2	38	63	24	77	94	35.7	69.9	13.3	M 12x45	1/2x1 3/4	1.28	PAFG106G2	210	210
2	51	G 1 1/2	34	69	25	90	103	42.9	77.8	13.3	M 12x45	1/2x1 3/4	1.59	PAFG108G112	210	210
2	51	G 2	42	69	25	90	103	42.9	77.8	13.3	M 12x45	1/2x1 3/4	1.62	PAFG108G	210	210

6000 PSI Series

1/2	13	G 3/8	10	38	16	47	56	18.2	40.5	8.9	M 08x30	5/16x1 1/4	0.24	PAFG401G38	420	420
1/2	13	G 1/2	12	40	16	47	56	18.2	40.5	8.9	M 08x30	5/16x1 1/4	0.24	PAFG401G	420	420
1/2	13	G 3/4	13	43	16	47	56	18.2	40.5	8.9	M 08x30	5/16x1 1/4	0.28	PAFG401G34	420	420
3/4	19	G 1/2	12	44	18	53	71	23.8	50.8	10.6	M 10x35	3/8x1 1/2	0.47	PAFG402G12	420	420
3/4	19	G 3/4	17	47	18	53	71	23.8	50.8	10.6	M 10x35	3/8x1 1/2	0.48	PAFG402G	420	420
3/4	19	G 1	19	49	18	53	71	23.8	50.8	10.6	M 10x35	3/8x1 1/2	0.54	PAFG402G1	420	420
1	25	G 3/4	17	54	21	68	81	27.8	57.2	13.3***	M 12x45	7/16x1 1/2	0.70	PAFG403G34	420	420
1	25	G 1	22	56	21	68	81	27.8	57.2	13.3***	M 12x45	7/16x1 1/2	0.78	PAFG403G	420	420
1	25	G 1 1/4	25	56	21	68	81	27.8	57.2	13.3***	M 12x45	7/16x1 1/2	0.80	PAFG403G114	420	420
1 1/4	32	G 1	22	61	24	78	94	31.8	66.6	15.0**	M 14x50	1/2x1 3/4	1.08	PAFG404G1	420	420
1 1/4	32	G 1 1/4	27	61	24	78	94	31.8	66.6	15.0**	M 14x50	1/2x1 3/4	1.13	PAFG404/12G1	420	420
1 1/4	32	G 1 1/4	27	61	24	78	94	31.8	66.6	13.3	M 12x50	-	1.13	PAFG404G	420	420
1 1/4	32	G 1 1/2	31	63	24	78	94	31.8	66.6	15.0**	M 14x50	1/2x1 3/4	1.15	PAFG404/12G	420	420
1 1/4	32	G 1 1/2	31	63	24	78	94	31.8	66.6	13.3	M 12x50	1/2x1 3/4	1.15	PAFG404G112	420	420
1 1/2	38	G 1 1/4	27	65	27	90	101	36.5	79.3	16.7	M 16x55	5/8x2 1/4	1.58	PAFG405G114	420	420
1 1/2	38	G 1 1/2	32	67	27	90	101	36.5	79.3	16.7	M 16x55	5/8x2 1/4	1.55	PAFG405G	420	420

Stainless steel parts may have dimensional deviations.
Additional information on request.

**DB = 13.3 for UNC Bolts

***DB = 12 for UNC Bolts

¹⁾ Pressure shown = Item deliverable

PN (bar) = PN (MPa) / 10

*Please add the suffixes below according to the material/surface required.

Order code suffixes					
Material	Suffix surface and material	Example only 4 bolt flange	Example 4 bolt flange incl. metr. bolts and O-ring	Example 4 bolt flange incl. UNC bolts and O-ring	Standard sealing material (no additional suffix needed)
Steel, zinc plated, Cr(VI)-free	CF	PAFG080GCF	PAFG080GCFM	PAFG080GCFU	NBR
Stainless steel	SS	PAFG080GSS	PAFG080GSSM	-	VIT

SAE Full flanges

PAFG-90G SAE 90° 4 bolt flange with BSPP 60° cone end

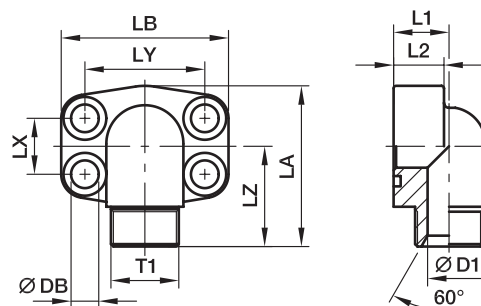
 SAE 90° Flange / BSPP 60° cone end
 (ISO 6162-1/-2) (ISO 8434-6)

3000 PSI Series

Nom. flange size		T1	D3	L1	L2	LA	LB	LX	LY	LZ	DB	Bolts		Weight (steel) kg/piece	Order code*	PN (bar) ¹⁾	
SAE (in.)	ISO (DN)											(metr.)	(unc.)			CF	SS
1/2	13	G 3/8	10	17	16	60	57	17.5	38.1	37	8.9	M 08×30	5/16×1 1/4	0.30	PAFG080/90G38	348	348
1/2	13	G 1/2	12	17	16	60	57	17.5	38.1	39	8.9	M 08×30	5/16×1 1/4	0.33	PAFG080/90G	348	348
1/2	13	G 3/4	13	20	16	60	57	17.5	38.1	40	8.9	M 08×30	5/16×1 1/4	0.31	PAFG080/90G34	348	348
3/4	19	G 1/2	12	20	18	63	66	22.3	47.6	41	10.6	M 10×35	3/8×1 1/2	0.47	PAFG100/90G12	348	348
3/4	19	G 3/4	17	20	18	63	66	22.3	47.6	44	10.6	M 10×35	3/8×1 1/2	0.45	PAFG100/90G	348	348
3/4	19	G 1	19	25	18	63	66	22.3	47.6	45	10.6	M 10×35	3/8×1 1/2	0.60	PAFG100/90G1	348	348
1	25	G 3/4	17	20	19	80	71	26.2	52.4	47	10.6	M 10×35	3/8×1 1/2	0.68	PAFG102/90G34	348	348
1	25	G 1	22	25	19	80	71	26.2	52.4	48	10.6	M 10×35	3/8×1 1/2	0.64	PAFG102/90G	348	348
1	25	G 1 1/4	25	31	19	80	71	26.2	52.4	49	10.6	M 10×40	3/8×1 1/2	0.81	PAFG102/90G114	348	348
1 1/4	32	G 1	22	25	22	84	80	30.2	58.7	54	10.6***	M 10×40	7/16×1 1/2	1.06	PAFG104/90G1	278	278
1 1/4	32	G 1 1/4	27	31	22	84	80	30.2	58.7	55	10.6***	M 10×35	7/16×1 1/2	0.93	PAFG104/90G	278	278
1 1/4	32	G 1 1/2	31	37	22	84	80	30.2	58.7	56	10.6***	M 10×40	7/16×1 1/2	0.96	PAFG104/90G112	278	278
1 1/2	38	G 1 1/4	27	31	25	88	94	35.7	69.9	59	13.3	M 12×45	1/2×1 3/4	1.44	PAFG106/90G114	210	210
1 1/2	38	G 1 1/2	34	37	25	88	94	35.7	69.9	61	13.3	M 12×45	1/2×1 3/4	1.49	PAFG106/90G	210	210

6000 PSI Series

1/2	13	G 3/8	10	17	16	60	57	18.2	40.5	37	8.9	M 08×30	5/16×1 1/4	0.30	PAFG401/90G38	420	420
1/2	13	G 1/2	12	17	16	60	57	18.2	40.5	39	8.9	M 08×30	5/16×1 1/4	0.32	PAFG401/90G	420	420
1/2	13	G 3/4	13	20	16	60	57	18.2	40.5	40	8.9	M 08×30	5/16×1 1/4	0.35	PAFG401/90G34	420	420
3/4	19	G 1/2	12	20	19	68	71	23.8	50.8	45	10.6	M 10×35	3/8×1 1/2	0.73	PAFG402/90G12	420	420
3/4	19	G 3/4	17	20	19	68	71	23.8	50.8	48	10.6	M 10×35	3/8×1 1/2	0.70	PAFG402/90G	420	420
3/4	19	G 1	19	25	19	68	71	23.8	50.8	50	10.6	M 10×35	3/8×1 1/2	0.75	PAFG402/90G1	420	420
1	25	G 3/4	17	25	24	83	80	27.8	57.2	52	13.3***	M 12×45	7/16×1 1/2	0.89	PAFG403/90G34	420	420
1	25	G 1	22	25	24	83	80	27.8	57.2	54	13.3***	M 12×45	7/16×1 1/2	0.90	PAFG403/90G	420	420
1	25	G 1 1/4	25	31	24	83	80	27.8	57.2	55	13.3***	M 12×45	7/16×1 1/2	1.07	PAFG403/90G114	420	420
1 1/4	32	G 1	22	31	25	97	94	31.8	66.6	59	15.0**	M 14×50	1/2×1 3/4	1.66	PAFG404/90G1	420	420
1 1/4	32	G 1	22	31	25	97	94	31.8	66.6	59	13.3	M 12×50	–	1.66	PAFG404/12/90G1	420	420
1 1/4	32	G 1 1/4	27	31	25	97	94	31.8	66.6	59	15.0**	M 14×50	1/2×1 3/4	1.59	PAFG404/90G	420	420
1 1/4	32	G 1 1/4	27	31	25	97	94	31.8	66.6	59	13.3	M 12×50	–	1.59	PAFG404/12/90G	420	420
1 1/4	32	G 1 1/2	31	37	25	97	94	31.8	66.6	61	15.0**	M 14×50	1/2×1 3/4	1.55	PAFG404/90G112	420	420
1 1/4	32	G 1 1/2	31	37	25	97	94	31.8	66.6	61	13.3	M 12×50	–	1.55	PAFG404/12/90G112	420	420
1 1/2	38	G 1 1/4	27	37	26	110	106	36.5	79.3	64	16.7	M 16×55	5/8×2 1/4	2.35	PAFG405/90G114	420	420
1 1/2	38	G 1 1/2	32	37	26	110	106	36.5	79.3	66	16.7	M 16×55	5/8×2 1/4	2.35	PAFG405/90G	420	420

1) Pressure shown = Item deliverable

**DB = 13.3 for UNC Bolts

***DB = 12 for UNC Bolts

$$\frac{\text{PN (bar)}}{10} = \text{PN (MPa)}$$

*Please add the suffixes below according to the material/surface required.

Stainless steel parts may have dimensional deviations.
Additional information on request.

Order code suffixes					
Material	Suffix surface and material	Example only 4 bolt flange	Example 4 bolt flange incl. metr. bolts and O-ring	Example 4 bolt flange incl. UNC bolts and O-ring	Standard sealing material (no additional suffix needed)
Steel, zinc plated, Cr(VI)-free	CF	PAFG080/90GCF	PAFG080/90GCFM	PAFG080/90GCFU	NBR
Stainless steel	SS	PAFG080/90GSS	PAFG080/90GSSM	–	VIT

PAFG-X SAE Straight 4 bolt flange with Triple-Lok® 37° flare end

SAE Flange / Triple-Lok® 37° flare end
(ISO 6162-1/-2)

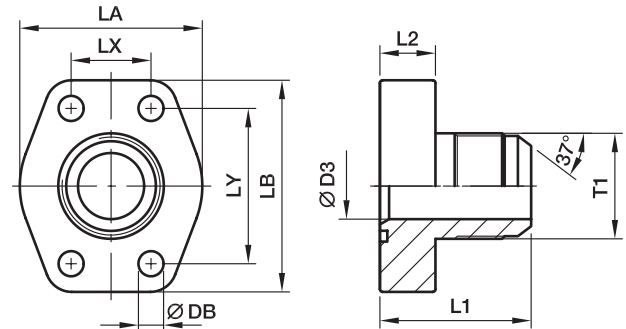

3000 PSI Series

Nom. flange size	SAE (in.)	ISO (DN)	T1	D3	L1	L2	LA	LB	LX	LY	DB	Bolts		Weight (steel) kg/piece	Order code*	PN (bar) ¹⁾	
												(metr.)	(unc.)			CF	SS
1/2	13	13	3/4-16UNF	9.9	41	16	47	57	17.5	38.1	8.9	M 08x30	5/16x1 1/4	0.25	PAFG080X-A	348	348
1/2	13	13	7/8-14UNF	12.3	41	16	47	57	17.5	38.1	8.9	M 08x30	5/16x1 1/4	0.25	PAFG080X-B	348	348
1/2	13	13	1 1/16-12UN	12.3	46	16	47	57	17.5	38.1	8.9	M 08x30	5/16x1 1/4	0.28	PAFG080X-C	348	348
3/4	19	19	7/8-14UN	12.3	47	18	50	66	22.3	47.6	10.6	M 10x35	3/8x1 1/2	0.35	PAFG100X-A	348	348
3/4	19	19	1 1/16-12UN	15.5	49	18	50	66	22.3	47.6	10.6	M 10x35	3/8x1 1/2	0.40	PAFG100X-B	348	348
3/4	19	19	1 5/16-12UN	21.5	50	18	50	66	22.3	47.6	10.6	M 10x35	3/8x1 1/2	0.41	PAFG100X-C	348	348
1	25	25	1 1/16-12UN	15.5	51	18	53	71	26.2	52.4	10.6	M 10x35	3/8x1 1/2	0.44	PAFG102X-A	348	348
1	25	25	1 5/16-12UN	21.5	52	18	53	71	26.2	52.4	10.6	M 10x35	3/8x1 1/2	0.46	PAFG102X-B	348	348
1	25	25	1 5/8-12UN	27.5	54	18	53	71	26.2	52.4	10.6	M 10x35	3/8x1 1/2	0.56	PAFG102X-C	348	348
1 1/4	32	32	1 5/16-12UN	21.5	56	21	69	81	30.2	58.7	10.6***	M 10x40	7/16x1 1/2	0.73	PAFG104X-A	278	278
1 1/4	32	32	1 5/8-12UN	27.5	58	21	69	81	30.2	58.7	10.6***	M 10x40	7/16x1 1/2	0.80	PAFG104X-B	278	278
1 1/4	32	32	1 7/8-12UN	33.0	61	21	69	81	30.2	58.7	10.6***	M 10x40	7/16x1 1/2	0.92	PAFG104X-C	278	278
1 1/2	38	38	1 5/8-12UN	27.5	64	24	77	94	35.7	69.9	13.3	M 12x45	1/2x1 3/4	1.17	PAFG106X-A	210	210
1 1/2	38	38	1 7/8-12UN	33.0	67	24	77	94	35.7	69.9	13.3	M 12x45	1/2x1 3/4	1.19	PAFG106X-B	210	210

6000 PSI Series

1/2	13	13	3/4-16UNF	9.9	42	16	47	57	18.2	40.5	8.9	M 08x30	5/16x1 1/4	0.26	PAFG401X-A	350	350
1/2	13	13	7/8-14UNF	12.3	45	16	47	57	18.2	40.5	8.9	M 08x30	5/16x1 1/4	0.26	PAFG401X-B	350	350
1/2	13	13	1 1/16-12UN	12.3	47	16	47	57	18.2	40.5	8.9	M 08x30	5/16x1 1/4	0.29	PAFG401X-C	350	350
3/4	19	19	7/8-14UN	12.3	49	18	53	71	23.8	50.8	10.6	M 10x35	3/8x1 1/2	0.45	PAFG402X-A	350	350
3/4	19	19	1 1/16-12UN	15.5	51	18	53	71	23.8	50.8	10.6	M 10x35	3/8x1 1/2	0.52	PAFG402X-B	350	350
3/4	19	19	1 5/16-12UN	21.5	52	18	53	71	23.8	50.8	10.6	M 10x35	3/8x1 1/2	0.52	PAFG402X-C	350	350
1	25	25	1 1/16-12UN	15.5	58	21	66	80	27.8	57.2	13.3***	M 12x45	7/16x1 1/2	0.70	PAFG403X-A	350	350
1	25	25	1 5/16-12UN	21.5	59	21	66	80	27.8	57.2	13.3***	M 12x45	7/16x1 1/2	0.71	PAFG403X-B	350	350
1	25	25	1 5/8-12UN	27.5	61	21	66	80	27.8	57.2	13.3***	M 12x45	7/16x1 1/2	0.82	PAFG403X-C	275	275
1 1/4	32	32	1 5/16-12UN	21.5	64	24	78	94	31.8	66.6	15.0**	M 14x50	1/2x1 3/4	1.07	PAFG404X-A	350	350
1 1/4	32	32	1 5/16-12UN	21.5	64	24	78	94	31.8	66.6	13.3	M 12x50	-	1.07	PAFG404/12X-A	350	350
1 1/4	32	32	1 5/8-12UN	27.5	66	24	78	94	31.8	66.6	15.0**	M 14x50	1/2x1 3/4	1.13	PAFG404X-B	275	275
1 1/4	32	32	1 5/8-12UN	27.5	66	24	78	94	31.8	66.6	13.3	M 12x50	-	1.13	PAFG404/12X-B	275	275
1 1/4	32	32	1 7/8-12UN	33.0	69	24	78	94	31.8	66.6	15.0**	M 14x50	1/2x1 3/4	1.10	PAFG404X-C	210	210
1 1/4	32	32	1 7/8-12UN	33.0	69	24	78	94	31.8	66.6	13.3	M 12x50	-	1.10	PAFG404/12X-C	210	210
1 1/2	38	38	1 5/8-12UN	27.5	70	27	90	106	36.5	79.3	16.7	M 16x55	5/8x2 1/4	1.60	PAFG405X-A	275	275
1 1/2	38	38	1 7/8-12UN	33.0	73	27	90	106	36.5	79.3	16.7	M 16x55	5/8x2 1/4	1.62	PAFG405X-B	210	210

¹⁾ Pressure shown = Item deliverable

**DB = 13.3 for UNC Bolts

PN (bar) / 10 = PN (MPa)

***DB = 12 for UNC Bolts

*Please add the suffixes below according to the material/surface required.

Stainless steel parts may have dimensional deviations. Additional information on request.

Order code suffixes					
Material	Suffix surface and material	Example only 4 bolt flange	Example 4 bolt flange incl. metr. bolts and O-ring	Example 4 bolt flange incl. UNC bolts and O-ring	Standard sealing material (no additional suffix needed)
Steel, zinc plated, Cr(VI)-free	CF	PAFG080X-ACF	PAFG080X-ACFM	PAFG080X-ACFU	NBR
Stainless steel	SS	PAFG080X-ASS	PAFG080X-ASSM	-	VIT

SAE Full flanges

PAFG-90X SAE 90° 4 bolt flange with Triple-Lok® 37° flare end

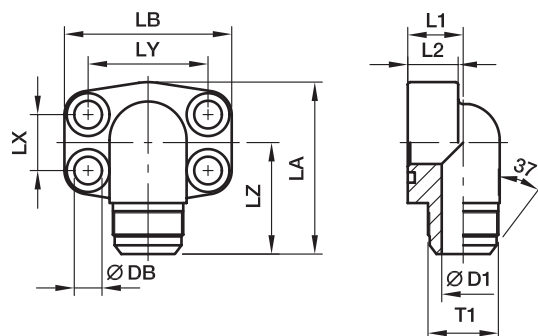
 SAE 90° Flange / Triple-Lok® 37° flare end
 (ISO 6162-1/-2)

3000 PSI Series

Nom. flange size		T1	D1	L1	L2	LA	LB	LX	LY	LZ	DB	Bolts		Weight (steel) kg/piece	Order code*	PN (bar) ¹⁾	
SAE (in.)	ISO (DN)											(metr.)	(unc.)			CF	SS
1/2	13	3/4-16	9.9	17	16	60	56	17.5	38.1	40	8.9	M 08x30	5/16x1 1/4	0.30	PAFG080/90X-A	348	348
1/2	13	7/8-14	12.3	17	16	60	56	17.5	38.1	42	8.9	M 08x30	5/16x1 1/4	0.30	PAFG080/90X-B	348	348
1/2	13	1 1/16-12	12.3	20	16	60	57	17.5	38.1	43	8.9	M 08x30	5/16x1 1/4	0.30	PAFG080/90X-C	348	348
3/4	19	7/8-14	12.3	20	18	63	66	22.3	47.6	45	10.6	M 10x35	3/8x1 1/2	0.50	PAFG100/90X-A	348	348
3/4	19	1 1/16-12	15.5	20	18	63	66	22.3	47.6	47	10.6	M 10x35	3/8x1 1/2	0.50	PAFG100/90X-B	348	348
3/4	19	1 5/16-12	21.5	25	18	63	66	22.3	47.6	48	10.6	M 10x35	3/8x1 1/2	0.58	PAFG100/90X-C	348	348
1	25	1 1/16-12	15.5	20	19	80	71	26.2	52.4	50	10.6	M 10x35	3/8x1 1/2	0.62	PAFG102/90X-A	348	348
1	25	1 5/16-12	21.5	25	19	80	71	26.2	52.4	51	10.6	M 10x35	3/8x1 1/2	0.68	PAFG102/90X-B	348	348
1 1/4	32	1 5/8-12	21.5	25	22	84	80	30.2	58.7	56	10.6***	M 10x40	7/16x1 1/2	1.06	PAFG104/90X-A	278	278
1 1/4	32	1 5/8-12	27.5	31	22	84	80	30.2	58.7	58	10.6***	M 10x40	7/16x1 1/2	1.03	PAFG104/90X-B	278	278
1 1/4	32	1 7/8-12	33.0	37	22	84	80	30.2	58.7	61	10.6***	M 10x40	7/16x1 1/2	0.96	PAFG104/90X-C	278	278
1 1/2	38	1 5/8-12	27.5	31	25	88	94	35.7	69.9	63	13.3	M 12x45	1/2x1 3/4	1.62	PAFG106/90X-A	210	210
1 1/2	38	1 7/8-12	33.0	37	25	88	94	35.7	69.9	66	13.3	M 12x45	1/2x1 3/4	1.53	PAFG106/90X-B	210	210

6000 PSI Series

1/2	13	3/4-16	9.9	17	16	60	57	18.2	40.5	40	8.9	M 08x30	5/16x1 1/4	0.30	PAFG401/90X-A	350	350
1/2	13	7/8-14	12.3	17	16	60	57	18.2	40.5	42	8.9	M 08x30	5/16x1 1/4	0.32	PAFG401/90X-B	350	350
1/2	13	1 1/16-12	12.3	20	16	60	57	18.2	40.5	43	8.9	M 08x30	5/16x1 1/4	0.35	PAFG401/90X-C	350	350
3/4	19	7/8-14	12.3	20	19	68	72	23.8	50.8	49	10.6	M 10x35	3/8x1 1/2	0.71	PAFG402/90X-A	350	350
3/4	19	1 1/16-12	15.5	20	19	68	72	23.8	50.8	51	10.6	M 10x35	3/8x1 1/2	0.67	PAFG402/90X-B	350	350
3/4	19	1 5/16-12	21.5	25	19	68	72	23.8	50.8	52	10.6	M 10x35	3/8x1 1/2	0.71	PAFG402/90X-C	350	350
1	25	1 1/16-12	15.5	25	24	90	80	27.8	57.2	55	13.3***	M 12x45	7/16x1 1/2	0.93	PAFG403/90X-A	350	350
1	25	1 5/16-12	25/21.5	25	24	90	80	27.8	57.2	56	13.3***	M 12x45	7/16x1 1/2	0.88	PAFG403/90X-B	350	350
1	25	1 5/8-12	27.5	31	24	90	80	27.8	57.2	58	13.3***	M 12x45	7/16x1 1/2	1.04	PAFG403/90X-C	275	275
1 1/4	32	1 5/16-12	21.5	31	25	97	94	31.8	66.6	56	15.0**	M 14x50	1/2x1 3/4	1.53	PAFG404/90X-A	350	350
1 1/4	32	1 5/16-12	21.5	31	25	97	94	31.8	66.6	56	13.3	M 12x50	-	1.53	PAFG404/12/90X-A	350	350
1 1/4	32	1 5/8-12	27.5	31	25	97	94	31.8	66.6	63	15.0**	M 14x50	1/2x1 3/4	1.56	PAFG404/90X-B	275	275
1 1/4	32	1 5/8-12	27.5	31	25	97	94	31.8	66.6	63	13.3	M 12x50	-	1.56	PAFG404/12/90X-B	275	275
1 1/4	32	1 7/8-12	33.0	37	25	97	94	31.8	66.6	63	15.0**	M 14x50	1/2x1 3/4	1.63	PAFG404/90X-C	210	210
1 1/4	32	1 7/8-12	33.0	37	25	97	94	31.8	66.6	63	13.3	M 12x50	-	1.63	PAFG404/12/90X-C	210	210
1 1/2	38	1 5/8-12	27.5	37	26	110	106	36.5	79.3	67	16.7	M 16x55	5/8x2 1/4	2.61	PAFG405/90X-A	275	275
1 1/2	38	1 7/8-12	33.0	37	26	110	106	36.5	79.3	70	16.7	M 16x55	5/8x2 1/4	2.49	PAFG405/90X-B	210	210

1) Pressure shown = Item deliverable

** DB = 13.3 for UNC Bolts

$$\frac{PN \text{ (bar)}}{10} = PN \text{ (MPa)}$$

***DB = 12 for UNC Bolts

*Please add the suffixes below according to the material/surface required.

Stainless steel parts may have dimensional deviations.
Additional information on request.

Order code suffixes					
Material	Suffix surface and material	Example only 4 bolt flange	Example 4 bolt flange incl. metr. bolts and O-ring	Example 4 bolt flange incl. UNC bolts and O-ring	Standard sealing material (no additional suffix needed)
Steel, zinc plated, Cr(VI)-free	CF	PAFG080/90X-ACF	PAFG080/90X-ACFM	PAFG080/90X-ACFU	NBR
Stainless steel	SS	PAFG080/90X-ASS	PAFG080/90X-ASSM	-	VIT

PAFG-L SAE Straight 4 bolt flange with O-Lok® ORFS end

SAE Flange / O-Lok® ORFS end
(ISO 6162-1/-2)

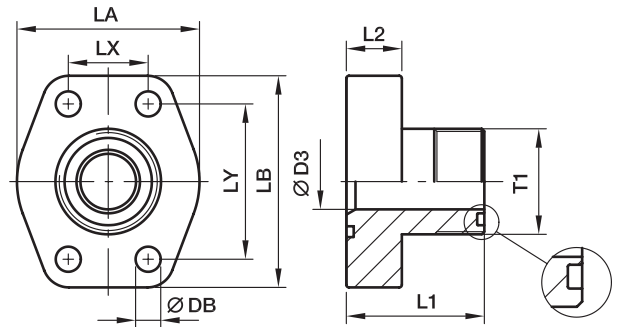

3000 PSI Series

Nom. flange size		T1	D3	L1	L2	LA	LB	LX	LY	DB	Bolts		Weight (steel) kg/piece	Order code*	PN (bar) ¹⁾	
SAE (in.)	ISO (DN)										(metr.)	(unc.)			CF	SS
1/2	13	11/16-16UN	6.0	37	16	47	56	17.5	38.1	8.9	M 08×30	5/16×1 1/4	0.24	PAFG080L-A	348	348
1/2	13	13/16-16UN	9.0	39	16	47	56	17.5	38.1	8.9	M 08×30	5/16×1 1/4	0.25	PAFG080L-B	348	348
1/2	13	1-14UN	12.0	42	16	47	56	17.5	38.1	8.9	M 08×30	5/16×1 1/4	0.27	PAFG080L-C	348	348
3/4	19	1-14UN	12.0	45	18	50	66	22.3	47.6	10.6	M 10×35	3/8×1 1/2	0.44	PAFG100L-A	348	348
3/4	19	1 3/16-12UN	15.0	47	18	50	66	22.3	47.6	10.6	M 10×35	3/8×1 1/2	0.46	PAFG100L-B	348	348
1	25	1 3/16-12UN	15.0	49	18	53	71	26.2	52.4	10.6	M 10×35	3/8×1 1/2	0.53	PAFG102L-A	348	348
1	25	1 7/16-12UN	20.0	49	18	53	71	26.2	52.4	10.6	M 10×35	3/8×1 1/2	0.54	PAFG102L-B	348	348
1 1/4	32	1 7/16-12UN	20.0	53	21	69	80	30.2	58.7	10.6***	M 10×40	7/16×1 1/2	0.80	PAFG104L-A	278	278
1 1/4	32	1 11/16-12UN	26.0	53	21	69	80	30.2	58.7	10.6***	M 10×40	7/16×1 1/2	0.83	PAFG104L-B	278	278
1 1/2	38	1 11/16-12UN	26.0	61	24	77	94	35.7	69.9	13.3	M 12×45	1/2×1 3/4	1.34	PAFG106L-A	210	210
1 1/2	38	2-12UN	32.0	61	24	77	94	35.7	69.9	13.3	M 12×45	1/2×1 3/4	1.20	PAFG106L-B	210	210

6000 PSI Series

1/2	13	11/16-16UN	6.0	38	16	47	57	18.2	40.5	8.9	M 08×30	5/16×1 1/4	0.25	PAFG401L-A	420	420
1/2	13	13/16-16UN	9.0	40	16	47	57	18.2	40.5	8.9	M 08×30	5/16×1 1/4	0.27	PAFG401L-B	420	420
1/2	13	1-14UN	12.5	43	16	47	57	18.2	40.5	8.9	M 08×30	5/16×1 1/4	0.28	PAFG401L-C	420	420
3/4	19	1-14UN	12.5	47	18	53	72	23.8	50.8	10.6	M 10×35	3/8×1 1/2	0.49	PAFG402L-A	420	420
3/4	19	1 3/16-12UN	15.0	49	18	53	72	23.8	50.8	10.6	M 10×35	3/8×1 1/2	0.51	PAFG402L-B	420	420
1	25	1 3/16-12UN	15.0	56	21	68	80	27.8	57.2	13.3***	M 12×45	7/16×1 1/2	0.75	PAFG403L-A	420	420
1	25	1 7/16-12UN	20.0	56	21	68	80	27.8	57.2	13.3***	M 12×45	7/16×1 1/2	0.77	PAFG403L-B	420	420
1 1/4	32	1 7/16-12UN	20.0	61	24	78	94	31.8	66.6	15.0**	M 14×50	1/2×1 3/4	1.15	PAFG404L-A	345	345
1 1/4	32	1 7/16-12UN	20.0	61	24	78	94	31.8	66.6	13.3	M 12×50	-	1.15	PAFG404/12L-A	345	345
1 1/4	32	1 11/16-12UN	26.0	61	24	78	94	31.8	66.6	15.0**	M 14×50	1/2×1 3/4	1.15	PAFG404L-B	345	345
1 1/4	32	1 11/16-12UN	26.0	61	24	78	94	31.8	66.6	13.3	M 12×50	-	1.15	PAFG404/12L-B	345	345
1 1/2	38	1 11/16-12UN	26.0	65	27	90	106	36.5	79.3	16.7	M 16×55	5/8×2 1/4	1.66	PAFG405L-A	310	310
1 1/2	38	2-12UN	32.0	67	27	90	106	36.5	79.3	16.7	M 16×55	5/8×2 1/4	1.75	PAFG405L-B	310	310

** DB = 13.3 for UNC Bolts

***DB = 12 for UNC Bolts

¹⁾Pressure shown = Item deliverable

PN (bar) / 10 = PN (MPa)

Stainless steel parts may have dimensional deviations. Additional information on request.

*Please add the suffixes below according to the material/surface required.

Order code suffixes					
Material	Suffix surface and material	Example only 4 bolt flange	Example 4 bolt flange incl. metr. bolts and O-ring	Example 4 bolt flange incl. UNC bolts and O-ring	Standard sealing material (no additional suffix needed)
Steel, zinc plated, Cr(VI)-free	CF	PAFG080L-ACF	PAFG080L-ACFM	PAFG080L-ACFU	NBR
Stainless steel	SS	PAFG080L-ASS	PAFG080L-ASSM	-	VIT

SAE Full flanges

PAFG-90L SAE 90° 4 bolt flange with O-Lok® ORFS end

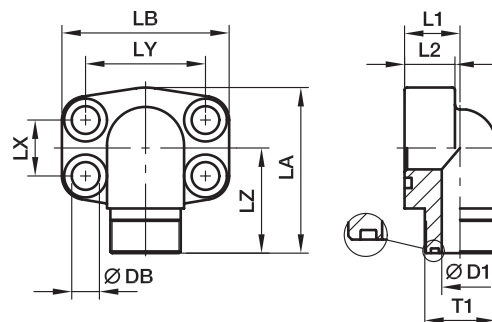
 SAE 90° Flange / O-Lok® ORFS end
 (ISO 6162-1/-2)

3000 PSI Series

Nom. flange size		T1	D1	L1	L2	LA	LB	LX	LY	LZ	DB	Bolts		Weight (steel) kg/piece	Order code*	PN (bar) ¹⁾	
SAE (in.)	ISO (DN)											(metr.)	(unc.)			CF	SS
1/2	13	11/16-16UN	6.5	17	16	60	57	17.5	38.1	37.0	8.9	M 08×30	5/16×1 1/4	0.31	PAFG080/90L-A	348	348
1/2	13	13/16-16UN	9.5	17	16	60	57	17.5	38.1	39.0	8.9	M 08×30	5/16×1 1/4	0.31	PAFG080/90L-B	348	348
1/2	13	1-14UN	12.5	20	16	60	57	17.5	38.1	36.5	8.9	M 08×30	5/16×1 1/4	0.31	PAFG080/90L-C	348	348
3/4	19	1-14UN	12.5	20	18	63	66	22.3	47.6	44.0	10.6	M 10×35	3/8×1 1/2	0.56	PAFG100/90L-A	348	348
3/4	19	1 3/16-12UN	15.5	25	24	63	66	22.3	47.6	45.0	10.6	M 10×35	3/8×1 1/2	0.60	PAFG100/90L-B	348	348
1	25	1 3/16-12UN	15.5	25	22	80	72	26.2	52.4	48.0	10.6	M 10×35	3/8×1 1/2	0.73	PAFG102/90L-A	348	348
1	25	1 7/16-12UN	20.5	31	19	80	72	26.2	52.4	42.5	10.6	M 10×35	3/8×1 1/2	0.64	PAFG102/90L-B	348	348
1 1/4	32	1 7/16-12UN	20.5	31	22	84	80	30.2	58.7	55.0	10.6***	M 10×40	7/16×1 1/2	1.15	PAFG104/90L-A	278	278
1 1/4	32	1 11/16-12UN	26.5	31	22	84	80	30.2	58.7	55.0	10.6***	M 10×40	7/16×1 1/2	1.08	PAFG104/90L-B	278	278
1 1/2	38	1 11/16-12UN	26.5	36	25	88	94	35.7	69.9	59.0	13.3	M 12×45	1/2×1 3/4	1.66	PAFG106/90L-A	210	210
1 1/2	38	2-12UN	32.5	37	25	88	94	35.7	69.9	61.0	13.3	M 12×45	1/2×1 3/4	1.60	PAFG106/90L-B	210	210

6000 PSI Series

1/2	13	11/16-16UN	16.0	17	16	60	57	18.2	40.5	37.0	8.9	M 08×30	5/16×1 1/4	0.33	PAFG401/90L-A	420	420
1/2	13	13/16-16UN	16.0	17	16	60	57	18.2	40.5	39.0	8.9	M 08×30	5/16×1 1/4	0.33	PAFG401/90L-B	420	420
1/2	13	1-14UN	16.0	20	16	60	57	18.2	40.5	40.0	8.9	M 08×30	5/16×1 1/4	0.33	PAFG401/90L-C	420	420
3/4	19	1-14UN	19.0	20	19	68	71	23.8	50.8	48.0	10.6	M 10×35	3/8×1 1/2	0.70	PAFG402/90L-A	420	420
3/4	19	1 3/16-12UN	19.0	25	19	68	71	23.8	50.8	50.0	10.6	M 10×35	3/8×1 1/2	0.73	PAFG402/90L-B	420	420
1	25	1 3/16-12UN	24.0	25	24	83	80	27.8	57.2	54.0	13.3***	M 12×45	7/16×1 1/2	0.96	PAFG403/90L-A	420	420
1	25	1 7/16-12UN	24.0	31	24	83	80	27.8	57.2	55.0	13.3***	M 12×45	7/16×1 1/2	1.14	PAFG403/90L-B	420	420
1 1/4	32	1 7/16-12UN	25.0	31	25	97	94	31.8	66.6	59.0	15.0**	M 14×50	1/2×1 3/4	1.76	PAFG404/90L-A	420	420
1 1/4	32	1 7/16-12UN	25.0	31	25	97	94	31.8	66.6	59.0	13.3	M 12×50	-	1.76	PAFG404/12/90L-A	420	420
1 1/4	32	1 11/16-12UN	25.0	31	25	97	94	31.8	66.6	59.0	15.0**	M 14×50	1/2×1 3/4	1.71	PAFG404/90L-B	345	345
1 1/4	32	1 11/16-12UN	25.0	31	25	97	94	31.8	66.6	59.0	13.3	M 12×50	-	1.71	PAFG404/12/90L-B	345	345
1 1/2	38	1 11/16-12UN	26.0	37	26	110	106	36.5	79.3	64.0	16.7	M 16×55	5/8×2 1/4	2.69	PAFG405/90L-A	345	345
1 1/2	38	2-12UN	26.0	37	26	110	106	36.5	79.3	66.0	16.7	M 16×55	5/8×2 1/4	2.50	PAFG405/90L-B	310	310

**DB = 13.3 for UNC Bolts

***DB = 12 for UNC Bolts

¹⁾Pressure shown = Item deliverable

$$\frac{PN \text{ (bar)}}{10} = PN \text{ (MPa)}$$

Stainless steel parts may have dimensional deviations. Additional information on request.

*Please add the suffixes below according to the material/surface required.

Order code suffixes					
Material	Suffix surface and material	Example only 4 bolt flange	Example 4 bolt flange incl. metr. bolts and O-ring	Example 4 bolt flange incl. UNC bolts and O-ring	Standard sealing material (no additional suffix needed)
Steel, zinc plated, Cr(VI)-free	CF	PAFG080/90L-ACF	PAFG080/90L-ACFM	PAFG080/90L-ACFU	NBR
Stainless steel	SS	PAFG080/90L-ASS	PAFG080/90L-ASSM	-	VIT

PAFS-B SAE Straight 4 bolt flange (butt weld)

SAE Flange / Butt weld tube end
(ISO 6162-1/-2)

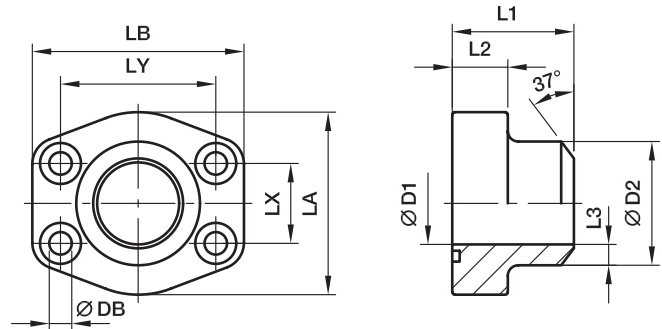

3000 PSI Series

Nom. flange size		⊕ max.	D1	D2	L1	L2	L3	LA	LB	LX	LY	DB	Bolts		Weight (steel) kg/piece	Order code*	PN (bar) ¹⁾	
SAE (in.)	ISO (DN)												(metr.)	(unc.)			S	SS
1/2	13	21.3	13	21.6	36	16	4.3	46	58	17.5	38.1	8.9	M 08×30	5/16×1 1/4	0.28	PAFS080B	345	345
3/4	19	26.9	19	27.2	36	18	4.1	49	66	22.3	47.6	10.6	M 10×35	3/8×1 1/2	0.36	PAFS100B	345	345
1	25	33.7	25	34.5	38	18	4.7	53	71	26.2	52.4	10.6	M 10×35	3/8×1 1/2	0.46	PAFS102B	345	345
1 1/4	32	42.4	31	42.8	41	21	5.9	69	81	30.2	58.7	10.6***	M 10×40	7/16×1 1/2	0.69	PAFS104B	276	276
1 1/2	38	48.3	38	48.6	44	25	5.3	77	94	35.7	69.9	13.3	M 12×45	1/2×1 3/4	1.01	PAFS106B	207	207
2	51	60.3	50	61.0	45	25	5.5	89	103	42.9	77.8	13.3	M 12×45	1/2×1 3/4	1.16	PAFS108B	207	207
2 1/2	64	76.1	63	76.6	50	25	6.8	101	115	50.8	88.9	13.3	M 12×45	1/2×1 3/4	1.45	PAFS110B	172	172
3	76	88.9	73	89.0	50	27	8.0	124	135	61.9	106.4	16.7	M 16×55	5/8×2 1/4	2.29	PAFS112B	138	138
3 1/2	89	101.6	89	103.0	50	27	7.0	134	153	69.9	120.7	16.7	M 16×55	5/8×2 1/4	2.80	PAFS114B	34	34
4	102	114.3	99	115.0	50	27	8.0	147	163	77.8	130.2	16.7	M 16×55	5/8×2 1/4	3.30	PAFS116B	34	34
5	127	140.0	120	141.0	50	28	10.5	180	184	92.1	152.4	16.7	M 16×55	5/8×2 1/4	4.50	PAFS118B	34	34

6000 PSI Series

1/2	13	17.2	10	17.5	36	16	3.7	46	58	18.2	40.5	8.9	M 08×30	5/16×1 1/4	0.28	PAFS401B38	420	420
1/2	13	21.3	13	21.6	36	16	4.3	46	58	18.2	40.5	8.9	M 08×30	5/16×1 1/4	0.28	PAFS401B	420	420
3/4	19	26.9	18	27.2	36	18	4.6	53	72	23.8	50.8	10.6	M 10×35	3/8×1 1/2	0.48	PAFS402B	420	420
1	25	33.7	22	34.5	44	24	6.3	68	81	27.8	57.2	10.6***	M 12×45	7/16×1 1/2	0.80	PAFS403B	420	420
1 1/4	32	42.4	28	42.8	44	27	7.4	78	95	31.8	66.6	15.0**	M 14×50	1/2×1 3/4	1.17	PAFS404B	420	420
1 1/4	32	42.4	28	42.8	44	27	7.4	78	95	31.8	66.6	13.3	M 12×50	-	1.17	PAFS404/12B	420	420
1 1/2	38	48.3	32	48.6	51	30	8.3	89	106	36.5	79.4	16.7	M 16×55	5/8×2 1/4	1.60	PAFS405B	420	420
2	51	60.3	41	61.0	70	37	10.0	116	135	44.5	96.8	20.6	M 20×70	3/4×2 3/4	3.50	PAFS406B	420	420
2 1/2	64	76.1	50	76.6	75	45	13.0	150	166	58.7	123.8	25.0	M 24×90	-	6.25	PAFS407B	420	420
3	76	88.9	58	90.0	90	55	16.0	178	208	71.4	152.4	32.0	M 30×110	-	12.25	PAFS408B	420	420

**DB = 13.3 for UNC Bolts

***DB = 12 for UNC Bolts

¹⁾Pressure shown = Item deliverable

$$\frac{PN(\text{bar})}{10} = PN(\text{MPa})$$

The pressures given here are the maximum allowable for the flange fittings. If the pipe or tube used has a lower pressure rating, then the welded assembly rating will be the lower one, assuming the weld is adequately strong.

Stainless steel parts may have dimensional deviations. Additional information on request.

*Please add the **suffixes** below according to the material/surface required.

Order code suffixes					
Material	Suffix surface and material	Example only 4 bolt flange	Example 4 bolt flange incl. metr. bolts and O-ring	Example 4 bolt flange incl. UNC bolts and O-ring	Standard sealing material (no additional suffix needed)
Steel, blanc oil dipped	S	PAFS080BS	PAFS080BSM	PAFS080BSU	NBR
Stainless steel	SS	PAFS080BSS	PAFS080BSSM	-	VIT

PGFS-B SAE Straight 4 bolt counter flange (butt weld)

SAE Counter flange / Butt weld tube end
(ISO 6162-1/-2)

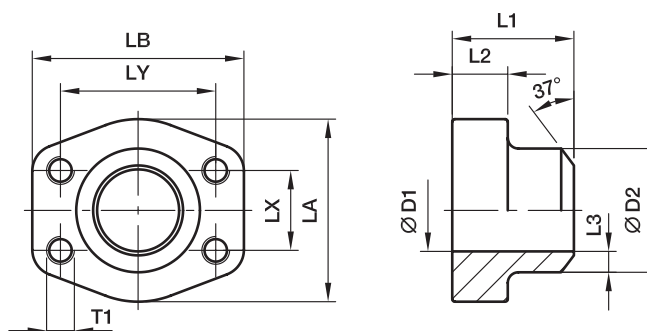

3000 PSI Series

Nom. flange size		⊕ max.	D1	D2	L1	L2	L3	LA	LB	LX	LY	Bolts		Weight (steel) kg/piece	Order code*	PN (bar ¹⁾)	
SAE (in.)	ISO (DN)											(metr.)	(unc.)			S	SS
1/2	13	21.3	13	21.6	36	16	4.3	47	57	17.5	38.1	M08	5/16	0.28	PGFS080B	345	345
3/4	19	26.9	19	27.2	36	18	4.1	49	66	22.3	47.6	M10	3/8	0.38	PGFS100B	345	345
1	25	33.7	25	34.5	38	18	4.7	53	71	26.2	52.4	M10	3/8	0.48	PGFS102B	345	345
1 1/4	32	42.4	31	42.8	41	21	5.9	69	80	30.2	58.7	M10	7/16	0.74	PGFS104B	276	276
1 1/2	38	48.3	38	48.6	44	25	5.3	77	94	35.7	69.9	M12	1/2	1.05	PGFS106B	207	207
2	51	60.3	50	61.0	45	25	5.5	89	103	42.9	77.8	M12	1/2	1.21	PGFS108B	207	207
2 1/2	64	76.1	63	76.6	50	25	6.8	101	115	50.8	88.9	M12	1/2	1.52	PGFS110B	172	172
3	76	88.9	73	89.0	50	27	8.0	124	135	61.9	106.4	M16	5/8	2.34	PGFS112B	138	138
3 1/2	89	101.6	89	103.0	50	27	7.0	134	153	69.9	120.7	M16	5/8	3.04	PGFS114B	34	34
4	102	114.3	99	115.0	50	27	8.0	147	163	77.8	130.2	M16	5/8	3.36	PGFS116B	34	34
5	127	140.0	120	141.0	50	28	10.5	180	184	92.1	152.4	M16	5/8	4.55	PGFS118B	34	34

6000 PSI Series

1/2	13	17.2	10	17.5	36	16	3.7	47	57	18.2	40.5	M08	5/16	0.29	PGFS401B38	420	420
1/2	13	21.3	13	21.6	36	16	4.3	47	57	18.2	40.5	M08	5/16	0.29	PGFS401B	420	420
3/4	19	26.9	18	27.2	36	19	4.6	53	71	23.8	50.8	M10	3/8	0.52	PGFS402B	420	420
1	25	33.7	22	34.5	44	24	6.3	66	82	27.8	57.2	M12	7/16	0.85	PGFS403B	420	420
1 1/4	32	42.4	28	42.8	44	27	7.4	78	95	31.8	66.6	M14	1/2	1.23	PGFS404B	420	420
1 1/4	32	42.4	28	42.8	44	27	7.4	78	95	31.8	66.6	M12	-	1.23	PGFS404/12B	420	420
1 1/2	38	48.3	32	48.6	51	30	8.3	89	106	36.5	79.3	M16	5/8	1.71	PGFS405B	420	420
2	51	60.3	41	61.0	70	37	10.0	116	135	44.5	96.8	M20	3/4	3.56	PGFS406B	420	420
2 1/2	64	76.1	50	76.6	75	45	13.0	150	166	58.7	123.8	M24	-	6.94	PGFS407B	420	420
3	76	88.9	58	90.0	90	55	16.0	178	208	71.4	152.4	M30	-	12.60	PGFS408B	420	420

¹⁾ Pressure shown = Item deliverable

$$\frac{\text{PN (bar)}}{10} = \text{PN (MPa)}$$

The pressures given here are the maximum allowable for the flange fittings. If the pipe or tube used has a lower pressure rating, then the welded assembly rating will be the lower one, assuming the weld is adequately strong.

Stainless steel parts may have dimensional deviations. Additional information on request.

*Please add the **suffixes** below according to the material/surface required.

Order code suffixes				
Material	Suffix surface and material	Example 4 bolt flange with metr. threads	Example 4 bolt flange with UNC threads	Standard sealing material (no additional suffix needed)
Steel, blanc oil dipped	S	PGFS080BSM	PGFS080BSU	NBR
Stainless steel	SS	PGFS080BSSM	PGFS080BSSU	VIT

PAFS-90B SAE 90° 4 bolt flange (butt weld)

SAE 90° Flange / Butt weld tube end
(ISO 6162-1/-2)

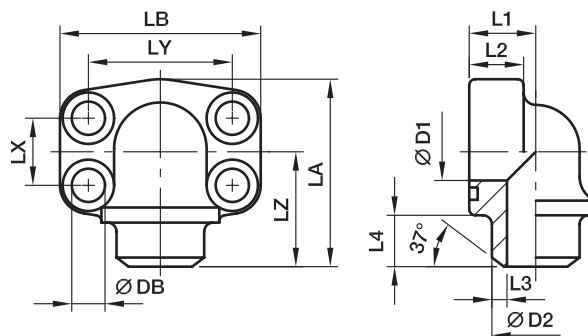

3000 PSI Series

Nom. flange size		max.	D1	D2	L1	L2	L3	L4	LA	LB	LX	LY	LZ	DB	Bolts		Weight (steel) kg/piece	Order code*	PN (bar) ¹⁾	
SAE (in.)	ISO (DN)														(metr.)	(unc.)			S	SS
1/2	13	21.3	13	21.6	18	16	4.3	12	63	57	17.5	38.1	40	8.9	M 08×30	5/16×1 1/4	0.31	PAFS080/90B	345	345
3/4	19	26.9	19	27.2	22	18	4.1	12	66	68	22.3	47.6	41	10.6	M 10×35	3/8×1 1/2	0.48	PAFS100/90B	345	345
1	25	33.7	25	34.5	28	19	4.7	13	77	74	26.2	52.4	50	10.6	M 10×35	3/8×1 1/2	0.72	PAFS102/90B	345	345
1 1/4	32	42.4	31	42.8	30	22	6.0	13	91	81	30.2	58.7	57	10.6***	M 10×40	7/16×1 1/2	1.01	PAFS104/90B	276	276
1 1/2	38	48.3	38	48.6	36	25	5.3	14	105	95	35.7	69.9	66	13.3	M 12×45	1/2×1 3/4	1.32	PAFS106/90B	207	207
2	51	60.3	50	61.0	41	25	5.5	15	110	105	42.9	77.8	66	13.3	M 12×45	1/2×1 3/4	1.74	PAFS108/90B	207	207
2 1/2	64	76.1	60	76.6	50	25	8.0	25	127	115	50.8	88.9	77	13.3	M 12×45	1/2×1 3/4	2.79	PAFS110/90B	172	172

6000 PSI Series

1/2	13	21.3	13	21.6	18	16	4.3	12	63	56	18.2	40.5	40	8.9	M 08×30	5/16×1 1/4	0.31	PAFS401/90B	420	420
3/4	19	26.9	18	27.2	28	20	4.6	12	77	72	23.8	50.8	50	10.6	M 10×35	3/8×1 1/2	0.76	PAFS402/90B	420	420
1	25	33.7	22	34.5	26	24	6.3	13	91	82	27.8	57.2	57	13.3***	M 12×45	7/16×1 1/2	0.91	PAFS403/90B	420	420
1 1/4	32	42.4	28	42.8	36	25	7.4	13	105	95	31.8	66.6	66	15.0**	M 14×50	1/2×1 3/4	1.65	PAFS404/90B	420	420
1 1/4	32	42.4	28	42.8	36	25	7.4	13	105	95	31.8	66.6	66	13.3*	M 12×50	–	1.65	PAFS404/12/90B	420	420
1 1/2	38	48.3	32	48.6	41	26	8.3	15	109	110	36.5	79.3	65	16.7	M 16×55	5/8×2 1/4	2.37	PAFS405/90B	420	420
2	51	60.3	41	61.0	45	35	10.0	15	133	134	44.5	96.8	75	20.6	M 20×70	3/4×2 3/4	4.06	PAFS406/90B	420	420

**DB = 13.3 for UNC Bolts

***DB = 12 for UNC Bolts

1) Pressure shown = Item deliverable

$\frac{PN(\text{bar})}{10} = PN(\text{MPa})$

The pressures given here are the maximum allowable for the flange fittings. If the pipe or tube used has a lower pressure rating, then the welded assembly rating will be the lower one, assuming the weld is adequately strong.

Stainless steel parts may have dimensional deviations. Additional information on request.

*Please add the **suffixes** below according to the material/surface required.

Order code suffixes					
Material	Suffix surface and material	Example only 4 bolt flange	Example 4 bolt flange incl. metr. bolts and O-ring	Example 4 bolt flange incl. UNC bolts and O-ring	Standard sealing material (no additional suffix needed)
Steel, blanc oil dipped	S	PAFS080/90BS	PAFS080/90BSM	PAFS080/90BSU	NBR
Stainless steel	SS	PAFS080/90BSS	PAFS080/90BSSM	–	VIT

SAE Full flanges

PAFS-S SAE Straight 4 bolt flange (socket weld)

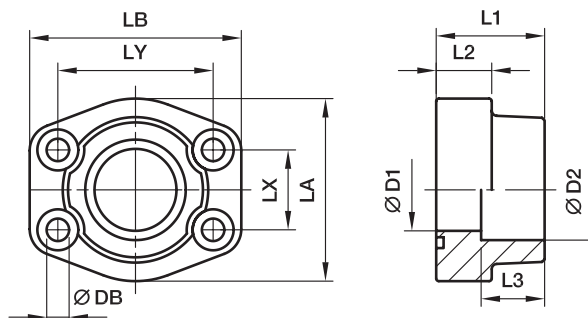
 SAE Flange / Socket weld tube end
 (ISO 6162-1/-2)

3000 PSI Series

Nom. flange size		⊕ max.	D1	D2	L1	L2	L3	LA	LB	LX	LY	DB	Bolts		Weight (steel) kg/piece	Order code*	PN (bar) ¹⁾	
SAE (in.)	ISO (DN)												(metr.)	(unc.)			S	SS
1/2	13	17.2	13	17.5	36	16	18	47	58	17.5	38.1	8.9	M 08×30	5/16×1 1/4	0.30	PAFS080S17.5	345	345
1/2	13	21.3	13	21.6	36	16	18	47	58	17.5	38.1	8.9	M 08×30	5/16×1 1/4	0.28	PAFS080S21.6	345	345
3/4	19	26.9	19	27.2	36	18	18	49	66	22.3	47.6	10.6	M 10×35	3/8×1 1/2	0.40	PAFS100S27.2	345	345
1	25	33.7	25	34.1	38	18	18	53	70	26.2	52.4	10.6	M 10×35	3/8×1 1/2	0.50	PAFS102S34.1	345	345
1 1/4	32	42.4	31	42.8	41	21	20	69	80	30.2	58.7	10.6***	M 10×40	7/16×1 1/2	0.72	PAFS104S42.8	276	276
1 1/2	38	48.3	38	48.6	44	25	22	77	94	35.7	69.9	13.3	M 12×45	1/2×1 3/4	1.08	PAFS106S48.6	207	207
2	51	60.3	50	61.0	45	25	24	89	103	42.9	77.8	13.3	M 12×45	1/2×1 3/4	1.16	PAFS108S61	207	207
2 1/2	64	76.1	63	76.6	50	25	28	101	115	50.8	88.9	13.3	M 12×45	1/2×1 3/4	1.40	PAFS110S76.6	172	172
3	76	88.9	73	90.5	50	27	28	124	135	61.9	106.4	16.7	M 16×55	5/8×2 1/4	2.23	PAFS112S90.5	138	138
3 1/2	89	101.6	89	103.0	50	27	28	137	153	69.9	120.7	16.7	M 16×55	5/8×2 1/4	2.92	PAFS114S103	34	34
4	102	114.3	99	115.5	50	27	28	147	163	77.8	130.2	16.7	M 16×55	5/8×2 1/4	3.05	PAFS116S115.5	34	34
5	127	140.0	120	142.0	50	28	28	180	184	92.1	152.4	16.7	M 16×55	5/8×2 1/4	4.21	PAFS118S142	34	34

6000 PSI Series

1/2	13	17.2	13	17.5	36	16	18	47	58	18.2	40.5	8.9	M 08×30	5/16×1 1/4	0.30	PAFS401S17.5	420	420
1/2	13	21.3	13	21.6	36	16	18	47	58	18.2	40.5	8.9	M 08×30	5/16×1 1/4	0.29	PAFS401S21.6	420	420
3/4	19	26.9	19	27.2	36	19	20	53	71	23.8	50.8	10.6	M 10×35	3/8×1 1/2	0.53	PAFS402S27.2	420	420
1	25	33.7	25	34.1	44	24	22	66	80	27.8	57.2	13.3***	M 12×45	7/16×1 1/2	0.85	PAFS403S34.1	420	420
1 1/4	32	42.4	31	42.8	44	27	22	77	94	31.8	66.6	15.0**	M 14×50	1/2×1 3/4	1.16	PAFS404S42.8	420	420
1 1/4	32	42.4	31	42.8	44	27	22	77	94	31.8	66.6	13.3	M 12×50	-	1.16	PAFS404/12S42.8	420	420
1 1/2	38	48.3	38	48.6	51	30	24	89	106	36.5	79.3	16.7	M 16×55	5/8×2 1/4	1.65	PAFS405S48.6	420	420
2	51	60.3	50	61.0	70	37	25	116	135	44.5	96.8	20.6	M 20×70	3/4×2 3/4	3.63	PAFS406S61	420	420
2 1/2	64	76.1	63	76.6	75	45	28	150	166	58.7	123.8	25.0	M 24×90	-	6.77	PAFS407S76.6	420	420
3	76	88.9	73	90.5	90	55	30	178	208	71.4	152.4	32.0	M 30×110	-	12.38	PAFS408S90.5	420	420

**DB = 13.3 for UNC Bolts

***DB = 12 for UNC Bolts

1) Pressure shown = Item deliverable

$$\frac{PN \text{ (bar)}}{10} = PN \text{ (MPa)}$$

The pressures given here are the maximum allowable for the flange fittings. If the pipe or tube used has a lower pressure rating, then the welded assembly rating will be the lower one, assuming the weld is adequately strong.

Stainless steel parts may have dimensional deviations. Additional information on request.

 *Please add the **suffixes** below according to the material/surface required.

Order code suffixes					
Material	Suffix surface and material	Example only 4 bolt flange	Example 4 bolt flange incl. metr. bolts and O-ring	Example 4 bolt flange incl. UNC bolts and O-ring	Standard sealing material (no additional suffix needed)
Steel, blanc oil dipped	S	PAFS080S17.5S	PAFS080S17.5SM	PAFS080S17.5SU	NBR
Stainless steel	SS	PAFS080S17.5SS	PAFS080S17.5SSM	-	VIT

PGFS-S SAE Straight counter 4 bolt flange (socket weld)

SAE Counter flange / Socket weld tube end
(ISO 6162-1/-2)

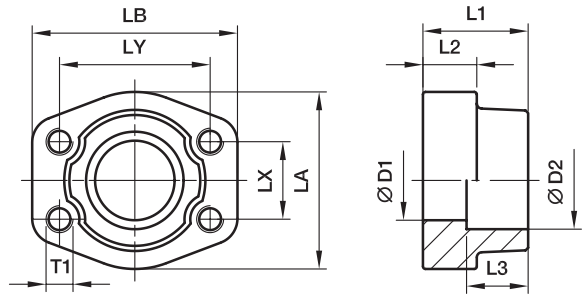

3000 PSI Series

Nom. flange size		max.	D1	D2	L1	L2	L3	LA	LB	LX	LY	DB	Bolts		Weight (steel) kg/piece	Order code*	PN (bar) ¹⁾	
SAE (in.)	ISO (DN)												(metr.)	(unc.)			S	SS
1/2	13	17.2	13	17.5	36	16	18	47	58	17.5	38.1	8.9	M 8	5/16	0.33	PGFS080S17.5	345	345
1/2	13	21.3	13	21.6	36	16	18	47	58	17.5	38.1	8.9	M 8	5/16	0.32	PGFS080S21.6	345	345
3/4	19	26.9	19	27.2	36	18	18	49	66	22.3	47.6	10.6	M10	3/8	0.42	PGFS100S27.2	345	345
1	25	33.7	25	34.1	38	18	18	53	70	26.2	52.4	10.6	M10	3/8	0.53	PGFS102S34.1	345	345
1 1/4	32	42.4	31	42.8	41	21	20	69	80	30.2	58.7	10.6***	M10	7/16	0.77	PGFS104S42.8	276	276
1 1/2	38	48.3	38	48.6	44	25	22	77	94	35.7	69.9	13.3	M12	1/2	1.14	PGFS106S48.6	207	207
2	51	60.3	50	61.0	45	25	24	89	103	42.9	77.8	13.3	M12	1/2	1.22	PGFS108S61	207	207
2 1/2	64	76.1	63	76.6	50	25	28	101	115	50.8	88.9	13.3	M12	1/2	1.50	PGFS110S76.6	172	172
3	76	88.9	73	90.5	50	27	28	124	135	61.9	106.4	16.7	M16	5/8	2.30	PGFS112S90.5	138	138
3 1/2	89	101.6	89	103.0	50	27	28	137	153	69.9	120.7	16.7	M16	5/8	2.64	PGFS114S103	34	34
4	102	114.3	99	115.5	50	27	28	147	163	77.8	130.2	16.7	M16	5/8	3.11	PGFS116S115.5	34	34
5	127	140.0	120	142.0	50	28	28	180	184	92.1	152.4	16.7	M16	5/8	4.31	PGFS118S142	34	34

6000 PSI Series

1/2	13	17.2	13	17.5	36	16	18	47	58	18.2	40.5	8.9	M 8	5/16	0.33	PGFS401S17.5	420	420
1/2	13	21.3	13	21.6	36	16	18	47	58	18.2	40.5	8.9	M 8	5/16	0.30	PGFS401S21.6	420	420
3/4	19	26.9	19	27.2	36	19	20	53	71	23.8	50.8	10.6	M10	3/8	0.57	PGFS402S27.2	420	420
1	25	33.7	25	34.1	44	24	22	66	80	27.8	57.2	13.3***	M12	7/16	0.89	PGFS403S34.1	420	420
1 1/4	32	42.4	31	42.8	44	27	22	77	94	31.8	66.6	15.0**	M14	1/2	1.22	PGFS404S42.8	420	420
1 1/4	32	42.4	31	42.8	44	27	22	77	94	31.8	66.6	13.3	M12	-	1.22	PGFS404/12S42.8	420	420
1 1/2	38	48.3	38	48.6	51	30	24	89	106	36.5	79.3	16.7	M16	5/8	1.78	PGFS405S48.6	420	420
2	51	60.3	50	61.0	70	37	25	116	135	44.5	96.8	20.6	M20	3/4	3.76	PGFS406S61	420	420
2 1/2	64	76.1	63	76.6	75	45	28	150	166	58.7	123.8	25.0	M24	-	7.28	PGFS407S76.6	420	420
3	76	88.9	73	90.5	90	55	30	178	208	71.4	152.4	30.0	M30	-	12.60	PGFS408S90.5	420	420

**DB = 13.3 for UNC Bolts

***DB = 12 for UNC Bolts

¹⁾Pressure shown = Item deliverable

PN (bar) = PN (MPa)
10

The pressures given here are the maximum allowable for the flange fittings. If the pipe or tube used has a lower pressure rating, then the welded assembly rating will be the lower one, assuming the weld is adequately strong.

Stainless steel parts may have dimensional deviations. Additional information on request.

*Please add the **suffixes** below according to the material/surface required.

Order code suffixes				
Material	Suffix surface and material	Example 4 bolt flange with metr. threads	Example 4 bolt flange with UNC threads	Standard sealing material (no additional suffix needed)
Steel, blanc oil dipped	S	PGFS080S17.5SM	PGFS080S17.5SU	NBR
Stainless steel	SS	PGFS080S17.5SSM	PGFS080S17.5SSU	VIT

PAFSF-S SAE Straight 4 bolt flange flat (socket weld)

SAE Flange / Socket weld tube end
(ISO 6162-1/-2)

only for low pressure applications

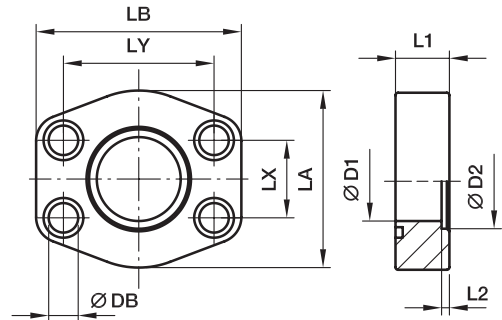

3000 PSI Series

Nom. flange size		max.											Bolts		Weight (steel) kg/piece	Order code*	PN (bar) ¹⁾	
SAE (in.)	ISO (DN)		D1	D2	L1	L2	LA	LB	LX	LY	DB	(metr.)	(unc.)	S			SS	
1/2	13	17.2	13	17.5	16	3	47	58	17.5	38.1	8.9	M 08x30	5/16x1 1/4	0.12	PAFSF080S17.5	40	40	
1/2	13	21.3	13	21.6	16	3	47	58	17.5	38.1	8.9	M 08x30	5/16x1 1/4	0.12	PAFSF080S21.6	40	40	
3/4	19	21.3	13	21.6	18	4	49	66	22.3	47.6	10.6	M 10x35	3/8x1 1/2	0.20	PAFSF100S21.6	40	40	
3/4	19	26.9	19	27.2	18	4	49	66	22.3	47.6	10.6	M 10x35	3/8x1 1/2	0.20	PAFSF100S27.2	40	40	
1	25	26.9	19	27.2	19	4	53	71	26.2	52.4	10.6	M 10x35	3/8x1 1/2	0.38	PAFSF102S27.2	40	40	
1	25	33.7	25	34.5	19	4	53	71	26.2	52.4	10.6	M 10x35	3/8x1 1/2	0.35	PAFSF102S34.5	40	40	
1 1/4	32	33.7	25	34.5	21	4	69	80	30.2	58.7	10.6***	M 10x40	7/16x1 1/2	0.40	PAFSF104S34.5	40	40	
1 1/4	32	42.4	31	42.8	21	4	69	80	30.2	58.7	10.6***	M 10x40	7/16x1 1/2	0.56	PAFSF104S42.8	40	40	
1 1/2	38	42.4	31	42.8	25	4	77	95	35.7	69.9	13.3	M 12x45	1/2x1 3/4	0.94	PAFSF106S42.8	40	40	
1 1/2	38	48.3	38	48.6	25	4	77	95	35.7	69.9	13.3	M 12x45	1/2x1 3/4	0.88	PAFSF106S48.6	40	40	
2	51	48.3	38	48.6	25	4	89	103	42.9	77.8	13.3	M 12x45	1/2x1 3/4	1.08	PAFSF108S48.6	40	40	
2	51	60.3	50	61.0	25	4	89	103	42.9	77.8	13.3	M 12x45	1/2x1 3/4	0.95	PAFSF108S61.0	40	40	
2 1/2	64	60.3	50	61.0	25	5	101	116	50.8	88.9	13.3	M 12x45	1/2x1 3/4	1.41	PAFSF110S61.0	40	40	
2 1/2	64	76.1	63	76.6	25	5	101	116	50.8	88.9	13.3	M 12x45	1/2x1 3/4	1.39	PAFSF110S76.6	40	40	
3	76	76.1	63	76.6	27	5	124	136	61.9	106.4	16.7	M 16x55	5/8x2 1/4	2.12	PAFSF112S76.6	30	30	
3	76	88.9	73	90.5	27	5	124	136	61.9	106.4	16.7	M 16x55	5/8x2 1/4	1.85	PAFSF112S90.5	30	30	
3 1/2	89	88.9	73	90.5	27	5	136	152	69.9	120.7	16.7	M 16x55	5/8x2 1/4	2.75	PAFSF114S90.5	30	30	
3 1/2	89	101.6	89	103.0	27	5	136	152	69.9	120.7	16.7	M 16x55	5/8x2 1/4	2.30	PAFSF114S103	30	30	
4	102	101.6	89	103.0	27	6	146	162	77.8	130.2	16.7	M 16x55	5/8x2 1/4	2.89	PAFSF116S103	30	30	
4	102	114.3	99	115.5	24	6	146	162	77.8	130.2	16.7	M 16x55	5/8x2 1/4	2.62	PAFSF116S115.5	30	30	
5	127	114.3	99	115.5	28	6	180	184	92.1	152.4	16.7	M 16x55	5/8x2 1/4	3.50	PAFSF118S115.5	30	30	
5	127	140.0	120	142.5	28	6	180	184	92.1	152.4	16.7	M 16x55	5/8x2 1/4	3.42	PAFSF118S142.5	30	30	

6000 PSI Series

1/2	13	17.2	13	17.5	16	4	47	58	18.2	40.5	8.9	M 08x30	5/16x1 1/4	0.25	PAFSF401S17.5	40	40
1/2	13	21.3	13	21.6	16	4	47	58	18.2	40.5	8.9	M 08x30	5/16x1 1/4	0.25	PAFSF401S21.6	40	40
3/4	19	21.3	13	21.6	19	4	53	71	23.8	50.8	10.6	M 10x35	3/8x1 1/2	0.50	PAFSF402S21.6	40	40
3/4	19	26.9	19	27.2	19	4	53	71	23.8	50.8	10.6	M 10x35	3/8x1 1/2	0.50	PAFSF402S27.2	40	40
1	25	26.9	19	27.2	24	4	66	80	27.8	57.2	13.3***	M 12x45	7/16x1 1/2	0.73	PAFSF403S27.2	40	40
1	25	33.7	25	34.5	24	4	66	80	27.8	57.2	13.3***	M 12x45	7/16x1 1/2	0.68	PAFSF403S34.5	40	40
1 1/4	32	33.7	25	34.5	27	4	77	94	31.8	66.6	15.0**	M 14x50	1/2x1 3/4	1.40	PAFSF404S34.5	40	40
1 1/4	32	33.7	25	34.5	27	4	77	94	31.8	66.6	13.3	M 12x50	-	1.40	PAFSF404/12S34.5	40	40
1 1/4	32	42.4	31	42.8	27	4	77	94	31.8	66.6	15.0**	M 14x50	1/2x1 3/4	1.35	PAFSF404S42.8	40	40
1 1/4	32	42.4	31	42.8	27	4	77	94	31.8	66.6	13.3	M 12x50	-	1.35	PAFSF404/12S42.8	40	40
1 1/2	38	42.4	31	42.8	30	4	89	103	36.5	79.3	16.7	M 16x55	5/8x2 1/4	1.30	PAFSF405S42.8	40	40
1 1/2	38	48.3	38	48.6	30	4	89	103	36.5	79.3	16.7	M 16x55	5/8x2 1/4	1.27	PAFSF405S48.6	40	40
2	51	48.3	38	48.6	37	4	123	135	44.5	96.8	20.6	M 20x70	3/4x2 3/4	3.03	PAFSF406S48.6	40	40
2	51	60.3	50	61.0	37	4	123	135	44.5	96.8	20.6	M 20x70	3/4x2 3/4	2.89	PAFSF406S61.0	40	40

The pressures given here are the maximum allowable for the flange fittings. If the pipe or tube used has a lower pressure rating, then the welded assembly rating will be the lower one, assuming the weld is adequately strong.
 **DB = 13.3 for UNC Bolts
 ***DB = 12 for UNC Bolts
 1) Pressure shown = Item deliverable

*Please add the suffixes below according to the material/surface required.

Order code suffixes					
Material	Suffix surface and material	Example only 4 bolt flange	Example 4 bolt flange incl. metr. bolts and O-ring	Example 4 bolt flange incl. UNC bolts and O-ring	Standard sealing material (no additional suffix needed)
Steel, blanc oil dipped	S	PAFSF080S17.5S	PAFSF080S17.5SM	PAFSF080S17.5SU	NBR
Stainless steel	SS	PAFSF080S17.5SS	PAFSF080S17.5SSM	-	VIT

PN (bar) = PN (MPa) / 10
Stainless steel parts may have dimensional deviations. Additional information on request.

PAFS-90S SAE 90° 4 bolt flange (socket weld)

SAE 90° Flange / Socket weld tube end
(ISO 6162-1/-2)

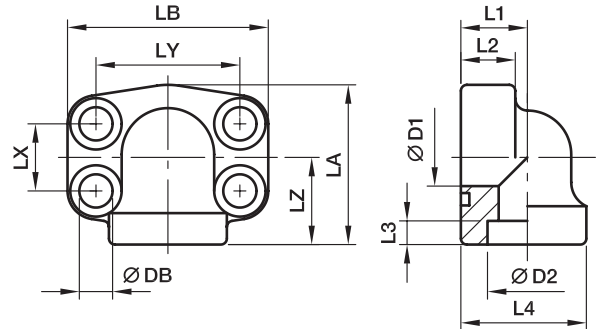

3000 PSI Series

Nom. flange size		⊕ max.	D1	D2	L1	L2	L3	L4	LA	LB	LX	LY	LZ	DB	Bolts		Weight (steel) kg/piece	Order code*	PN (bar) ¹⁾	
SAE (in.)	ISO (DN)														(metr.)	(unc.)			S	SS
1/2	13	21.3	13	21.6	18	17	5	34.0	51	57	17.5	38.1	28	8.9	M 08×30	5/16×1 1/4	0.45	PAFS080/90S21.6	345	345
3/4	19	26.9	19	27.2	22	18	5	38.5	50	68	22.2	47.6	25	10.6	M 10×35	3/8×1 1/2	0.50	PAFS100/90S27.2	345	345
1	25	33.7	25	34.1	28	19	6	44.5	55	72	26.2	52.4	28	10.6	M 10×35	3/8×1 1/2	0.55	PAFS102/90S34.1	345	345
1 1/4	32	42.4	31	42.8	30	22	7	53.5	68	82	30.2	58.7	34	10.6***	M 10×40	7/16×1 1/2	0.88	PAFS104/90S42.8	276	276
1 1/2	38	48.3	38	48.6	36	25	8	62.5	82	95	35.7	69.9	43	13.3	M 12×45	1/2×1 3/4	1.28	PAFS106/90S48.6	207	207
2	51	60.3	50	61.0	41	25	10	77.0	94	105	42.9	77.8	50	13.3	M 12×45	1/2×1 3/4	1.72	PAFS108/90S61	207	207
2 1/2	64	76.1	60	76.6	50	25	28	85.0	127	115	50.8	88.9	77	13.3	M 12×45	1/2×1 3/4	3.11	PAFS110/90S76.6	172	172

6000 PSI Series

1/2	13	21.3	13	21.6	18	17	5	34.0	51	57	18.2	40.5	28	8.9	M 08×30	5/16×1 1/4	0.35	PAFS401/90S21.6	420	420
3/4	19	26.9	19	27.2	28	19	6	44.5	55	72	23.8	50.8	28	10.6	M 10×35	3/8×1 1/2	0.76	PAFS402/90S27.2	420	420
1	25	33.7	25	34.1	30	24	7	53.5	68	82	27.8	57.2	34	13.3***	M 12×50	7/16×1 1/2	0.96	PAFS403/90S34.1	420	420
1 1/4	32	42.4	31	42.8	36	25	8	62.5	82	95	31.8	66.6	43	15.0**	M 14×45	1/2×1 3/4	1.77	PAFS404/90S42.8	420	420
1 1/4	32	42.4	31	42.8	36	25	8	62.5	82	95	31.8	66.6	43	13.3	M 12×45	-	1.77	PAFS404/12/90S42.8	420	420
1 1/2	38	48.3	38	48.6	41	26	10	77.0	94	110	36.5	79.3	50	16.7	M 16×55	5/8×2 1/4	2.24	PAFS405/90S48.6	420	420
2	51	60.3	50	61.0	45	35	12	89.0	123	134	44.5	96.8	65	20.6	M 20×70	3/4×2 3/4	3.48	PAFS406/90S61	420	420

**DB = 13.3 for UNC Bolts

***DB = 12 for UNC Bolts

1) Pressure shown = Item deliverable

PN (bar) = PN (MPa) / 10

The pressures given here are the maximum allowable for the flange fittings. If the pipe or tube used has a lower pressure rating, then the welded assembly rating will be the lower one, assuming the weld is adequately strong.

Stainless steel parts may have dimensional deviations. Additional information on request.

*Please add the **suffixes** below according to the material/surface required.

Order code suffixes					
Material	Suffix surface and material	Example only 4 bolt flange	Example 4 bolt flange incl. metr. bolts and O-ring	Example 4 bolt flange incl. UNC bolts and O-ring	Standard sealing material (no additional suffix needed)
Steel, blanc oil dipped	S	PAFS080/90S21.6S	PAFS080/90S21.6SM	PAFS080/90S21.6SU	NBR
Stainless steel	SS	PAFS080/90S21.6SS	PAFS080/90S21.6SSM	-	VIT

PDFS-G SAE Straight 4 bolt flange connection

SAE Flange / Female BSP thread
(ISO 6162-1/-2)

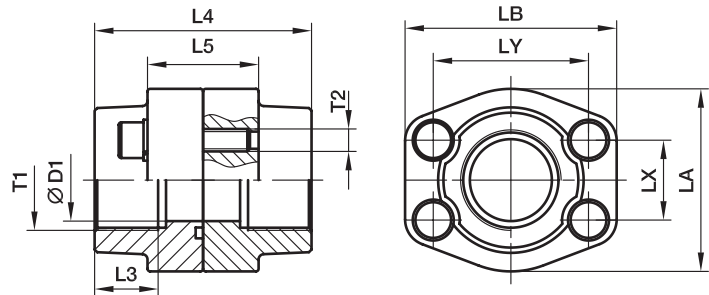

3000 PSI Series

Nom. flange size		T1	D1	L3	L4	L5	LA	LB	LX	LY	T2		Weight (steel) kg/piece	Order code*	PN (bar) ¹⁾	
SAE (in.)	ISO (DN)										(metr.)	(unc.)			S	SS
1/2	13	G 3/8	13	19	72	32	47	57	17.5	38.1	M 8	5/16	0.71	PDFS080G38	345	345
1/2	13	G 1/2	13	19	72	32	47	57	17.5	38.1	M 8	5/16	0.67	PDFS080G	345	345
3/4	19	G 3/4	19	19	72	36	49	66	22.3	47.6	M10	3/8	0.97	PDFS100G	345	345
1	25	G 1	25	19	76	36	53	71	26.2	52.4	M10	3/8	1.13	PDFS102G	345	345
1 1/4	32	G 1 1/4	31	22	82	42	69	80	30.2	58.7	M10	7/16	1.63	PDFS104G	276	276
1 1/2	38	G 1 1/2	38	24	88	48	77	94	35.7	69.9	M12	1/2	2.49	PDFS106G	207	207
2	51	G 2	50	26	90	48	89	103	42.9	77.8	M12	1/2	2.68	PDFS108G	207	207
2 1/2	64	G 2 1/2	63	30	100	48	101	115	50.8	88.9	M12	1/2	3.22	PDFS110G	172	172
3	76	G 3	73	34	100	53	124	135	61.9	106.4	M16	5/8	3.10	PDFS112G	138	138
3 1/2	89	G 3 1/2	89	27	100	54	136	152	69.9	120.7	M16	5/8	4.20	PDFS114G	34	34
4	102	G 4	99	30	100	54	146	162	77.8	130.2	M16	5/8	6.76	PDFS116G	34	34
5	127	G 5	120	30	100	54	180	184	92.1	152.4	M16	5/8	7.00	PDFS118G	34	34

6000 PSI Series

1/2	13	G 3/8	13	19	72	32	47	57	18.2	40.5	M 8	5/16	0.68	PDFS401G38	420	420
1/2	13	G 1/2	13	19	72	32	47	57	18.2	40.5	M 8	5/16	0.68	PDFS401G	420	420
3/4	19	G 3/4	19	22	72	38	53	71	23.8	50.8	M10	3/8	1.23	PDFS402G	420	420
1	25	G 1	25	24	88	48	69	80	27.8	57.2	M12	7/16	1.98	PDFS403G	420	420
1 1/4	32	G 1 1/4	31	25	88	54	77	94	31.8	66.6	M14	1/2	2.71	PDFS404G	420	420
1 1/4	32	G 1 1/4	31	25	88	54	77	94	31.8	66.6	M12	-	2.71	PDFS404/12G	420	420
1 1/2	38	G 1 1/2	38	28	102	60	89	106	36.5	79.3	M16	5/8	4.25	PDFS405G	420	420
2	51	G 2	50	33	140	74	116	135	44.5	96.8	M20	3/4	8.10	PDFS406G	420	420
2 1/2	64	G 2 1/2	63	35	150	90	150	166	58.7	123.8	M24	-	15.66	PDFS407G	420	420
3	76	G 3	73	40	180	110	178	208	71.4	152.4	M30	-	20.00	PDFS408G	420	420

¹⁾ Pressure shown = Item deliverable

$$\frac{PN \text{ (bar)}}{10} = PN \text{ (MPa)}$$

Stainless steel parts may have dimensional deviations. Additional information on request.

*Please add the **suffixes** below according to the material/surface required.

Order code suffixes				
Material	Suffix surface and material	Example 4 bolt flange coupling incl. metr. bolts and O-ring	Example 4 bolt flange coupling incl. UNC bolts and O-ring	Standard sealing material (no additional suffix needed)
Steel, zinc plated, Cr(VI)-free	CF	PDFS080GCF	PDFS080GCFU	NBR
Stainless steel	SS	PDFS080GSS	-	VIT

PDFS-B SAE Straight 4 bolt flange connection (butt weld)

SAE Flange / Butt weld tube end
(ISO 6162-1/-2)

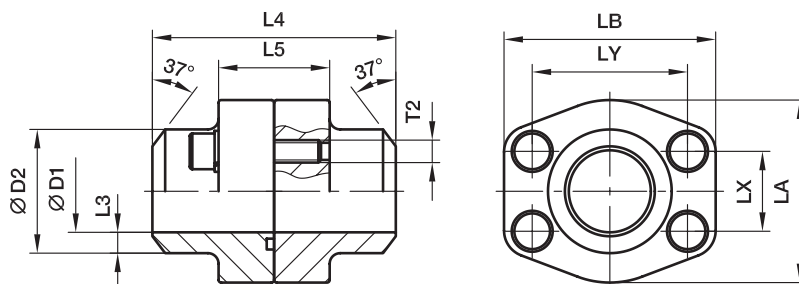

3000 PSI Series

Nom. flange size		⊕ max.	D1	D2	L3	L4	L5	LA	LB	LX	LY	T2		Weight (steel) kg/piece	Order code*	PN (bar ¹⁾)	
SAE (in.)	ISO (DN)											(metr.)	(unc.)			S	SS
1/2	13	21.3	13	21.6	4.3	72	32	47	57	17.5	38.1	M 8	5/16	0.64	PDFS080B	345	345
3/4	19	26.9	19	27.2	4.1	72	36	49	66	22.3	47.6	M10	3/8	0.85	PDFS100B	345	345
1	25	33.7	25	34.5	4.7	76	36	53	71	26.2	52.4	M10	3/8	1.05	PDFS102B	345	345
1 1/4	32	42.4	31	42.8	6.0	82	42	69	80	30.2	58.7	M10	7/16	1.55	PDFS104B	276	276
1 1/2	38	48.3	38	48.6	5.3	88	48	77	94	35.7	69.9	M12	1/2	2.31	PDFS106B	207	207
2	51	60.3	50	61.0	5.5	90	48	89	103	42.9	77.8	M12	1/2	2.64	PDFS108B	207	207
2 1/2	64	76.1	63	76.6	6.8	100	48	101	115	50.8	88.9	M12	1/2	3.32	PDFS110B	172	172
3	76	88.9	73	89.0	8.0	100	53	124	135	61.9	106.4	M16	5/8	5.18	PDFS112B	138	138
3 1/2	89	101.6	89	103.0	7.0	100	54	137	153	69.9	120.7	M16	5/8	6.00	PDFS114B	34	34
4	102	114.3	99	115.0	8.0	100	54	147	163	77.8	130.2	M16	5/8	7.31	PDFS116B	34	34
5	127	140.0	120	141.0	10.5	100	54	180	184	92.1	152.4	M16	5/8	9.18	PDFS118B	34	34

6000 PSI Series

1/2	13	17.2	10	17.5	3.7	72	32	47	57	18.2	40.5	M 8	5/16	0.63	PDFS401B38	420	420
1/2	13	21.3	13	21.6	4.3	72	32	47	57	18.2	40.5	M 8	5/16	0.64	PDFS401B	420	420
3/4	19	26.9	18	27.2	4.6	72	38	53	71	23.8	50.8	M10	3/8	1.34	PDFS402B	420	420
1	25	33.7	22	34.5	6.3	88	48	66	80	27.8	57.2	M12	7/16	1.86	PDFS403B	420	420
1 1/4	32	42.4	28	42.8	7.4	88	54	77	94	31.8	66.5	M14	1/2	2.81	PDFS404B	420	420
1 1/4	32	42.4	28	42.8	7.4	88	54	77	94	31.8	66.5	M12	-	2.81	PDFS404/12B	420	420
1 1/2	38	48.3	32	48.6	8.3	102	60	89	106	36.5	79.3	M16	5/8	3.84	PDFS405B	420	420
2	51	60.3	41	61.0	10.0	140	74	116	135	44.5	96.8	M20	3/4	8.10	PDFS406B	420	420
2 1/2	64	76.1	50	76.6	13.0	150	90	150	166	58.7	123.8	M24	-	14.72	PDFS407B	420	420
3	76	88.9	58	90.0	16.0	180	110	178	208	71.4	152.4	M30	-	27.80	PDFS408B	420	420

¹⁾ Pressure shown = Item deliverable

$$\frac{\text{PN (bar)}}{10} = \text{PN (MPa)}$$

The pressures given here are the maximum allowable for the flange fittings. If the pipe or tube used has a lower pressure rating, then the welded assembly rating will be the lower one, assuming the weld is adequately strong.

Stainless steel parts may have dimensional deviations. Additional information on request.

*Please add the **suffixes** below according to the material/surface required.

Order code suffixes				
Material	Suffix surface and material	Example 4 bolt flange coupling incl. metr. bolts and O-ring	Example 4 bolt flange coupling incl. UNC bolts and O-ring	Standard sealing material (no additional suffix needed)
Steel, blanc oil dipped	S	PDFS080BS	PDFS080BSU	NBR
Stainless steel	SS	PDFS080BSS	-	VIT

PDFS-S SAE Straight 4 bolt flange connection (socket weld)

SAE Flange / Socket weld tube end
(ISO 6162-1/-2)

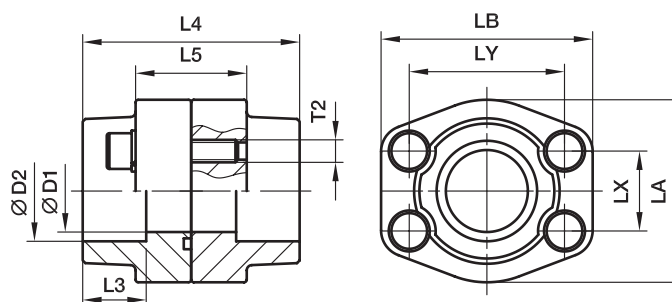

3000 PSI Series

Nom. flange size		⊕ max.	D1	D2	L3	L4	L5	LA	LB	LX	LY	T2		Weight (steel) kg/piece	Order code*	PN (bar) ¹⁾	
SAE (in.)	ISO (DN)											(metr.)	(unc.)			S	SS
1/2	13	17.2	13	17.5	18	72	36	47	57	17.5	38.1	M 8	5/16	0.70	PDFS080S17.5	345	345
1/2	13	21.3	13	21.6	18	72	36	47	57	17.5	38.1	M 8	5/16	0.67	PDFS080S21.6	345	345
3/4	19	26.9	19	27.2	18	72	36	49	66	22.3	47.6	M10	3/8	1.00	PDFS100S27.2	345	345
1	25	33.7	25	34.1	18	76	36	53	71	26.2	52.4	M10	3/8	1.13	PDFS102S34.1	345	345
1 1/4	32	42.4	31	42.8	20	82	42	69	80	30.2	58.7	M10	7/16	1.63	PDFS104S42.8	276	276
1 1/2	38	48.3	38	48.6	22	88	48	77	94	35.7	69.9	M12	1/2	2.47	PDFS106S48.6	207	207
2	51	60.3	50	61.0	24	90	48	89	103	42.9	77.8	M12	1/2	2.60	PDFS108S61	207	207
2 1/2	64	76.1	63	76.6	28	100	48	101	116	50.8	88.9	M12	1/2	3.21	PDFS110S76.6	172	172
3	76	88.9	73	90.5	28	100	53	124	135	61.9	106.4	M16	5/8	5.08	PDFS112S90.5	138	138
3 1/2	89	101.6	89	103.0	28	100	54	137	153	69.9	120.7	M16	5/8	5.91	PDFS114S103	34	34
4	102	114.3	99	115.5	28	100	54	147	163	77.8	130.2	M16	5/8	6.50	PDFS116S115.5	34	34
5	127	140.0	120	142.0	28	100	54	180	184	92.1	152.4	M16	5/8	8.62	PDFS118S142	34	34

6000 PSI Series

1/2	13	17.2	13	17.5	18	72	32	47	57	18.2	40.5	M 8	5/16	0.66	PDFS401S17.5	420	420
1/2	13	21.3	13	21.6	18	72	32	47	57	18.2	40.5	M 8	5/16	0.60	PDFS401S21.6	420	420
3/4	19	26.9	19	27.2	20	72	38	53	71	23.8	50.8	M10	3/8	1.14	PDFS402S27.2	420	420
1	25	33.7	25	34.1	22	88	48	66	80	27.8	57.2	M12	7/16	1.78	PDFS403S34.1	420	420
1 1/4	32	42.4	31	42.8	22	88	54	77	94	31.8	66.6	M14	1/2	2.44	PDFS404S42.8	420	420
1 1/4	32	42.4	31	42.8	22	88	54	77	94	31.8	66.6	M12	-	2.44	PDFS404/12S42.8	420	420
1 1/2	38	48.3	38	48.6	24	102	60	89	106	36.5	79.3	M16	5/8	3.54	PDFS405S48.6	420	420
2	51	60.3	50	61.0	25	140	74	116	135	44.5	96.8	M20	3/4	7.52	PDFS406S61	420	420
2 1/2	64	76.1	63	76.6	28	150	90	150	166	58.7	123.8	M24	-	14.56	PDFS407S76.6	420	420
3	76	88.9	73	90.5	30	180	110	178	208	71.4	152.4	M30	-	25.20	PDFS408S90.5	420	420

¹⁾ Pressure shown = Item deliverable

$$\frac{\text{PN (bar)}}{10} = \text{PN (MPa)}$$

The pressures given here are the maximum allowable for the flange fittings. If the pipe or tube used has a lower pressure rating, then the welded assembly rating will be the lower one, assuming the weld is adequately strong.

Stainless steel parts may have dimensional deviations. Additional information on request.

*Please add the **suffixes** below according to the material/surface required.

Order code suffixes				
Material	Suffix surface and material	Example 4 bolt flange coupling incl. metr. bolts and O-ring	Example 4 bolt flange coupling incl. UNC bolts and O-ring	Standard sealing material (no additional suffix needed)
Steel, blanc oil dipped	S	PDFS080S17.5S	PDFS080S17.5SU	NBR
Stainless steel	SS	PDFS080S17.5SS	-	VIT

PCFF SAE Closed flange

SAE Closed flange
(ISO 6162-1/-2)

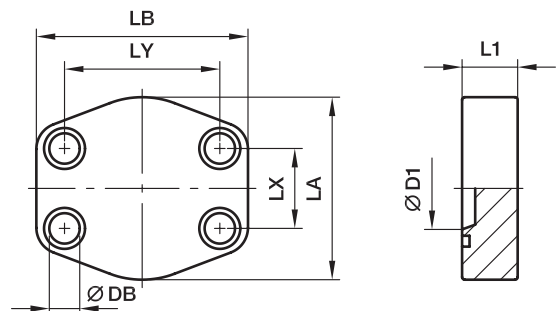

3000 PSI Series

Nom. flange size		D1	L1	LA	LB	LX	LY	DB	Bolts		Weight (steel) kg/piece	Order code*	PN (bar) ¹⁾	
SAE (in.)	ISO (DN)								(metr.)	(unc.)			S	SS
1/2	13	13	16	47	58	17.5	38.1	8.9	M 08×30	5/16×1 1/4	0.25	PCFF32	345	345
3/4	19	16	18	49	66	22.3	47.6	10.6	M 10×35	3/8×1 1/2	0.36	PCFF33	345	345
1	25	25	19	53	71	26.2	52.4	10.6	M 10×35	3/8×1 1/2	0.43	PCFF34	345	345
1 1/4	32	25	21	69	80	30.2	58.7	10.6***	M 10×40	7/16×1 1/2	0.71	PCFF35	276	276
1 1/2	38	34	25	77	95	35.7	69.9	13.3	M 12×45	1/2×1 3/4	1.11	PCFF36	207	207
2	51	43	25	89	103	42.9	77.8	13.3	M 12×45	1/2×1 3/4	1.38	PCFF38	207	207
2 1/2	64	61	25	101	116	50.8	88.9	13.3	M 12×45	1/2×1 3/4	1.77	PCFF310	172	172
3	76	58	27	124	136	61.9	106.4	16.7	M 16×55	5/8×2 1/4	2.72	PCFF312	138	138
3 1/2	89	73	27	136	152	69.9	120.7	16.7	M 16×55	5/8×2 1/4	3.77	PCFF314	34	34
4	102	87	27	146	162	77.8	130.2	16.7	M 16×55	5/8×2 1/4	4.20	PCFF316	34	34
5	127	127	25	180	184	92.1	152.4	16.7	M 16×55	5/8×2 1/4	6.42	PCFF320	34	34

6000 PSI Series

1/2	13	13	16	47	58	18.2	40.5	8.9	M 08×30	5/16×1 1/4	0.25	PCFF62	420	420
3/4	19	20	19	53	71	23.8	50.8	10.6	M 10×35	3/8×1 1/2	0.46	PCFF63	420	420
1	25	25	24	66	80	27.8	57.2	13.3***	M 12×45	7/16×1 1/2	0.78	PCFF64	420	420
1 1/4	32	25	27	77	94	31.8	66.6	15.0**	M 14×50	1/2×1 3/4	1.17	PCFF65	420	420
1 1/4	32	25	27	77	94	31.8	66.6	13.3	M 12×50	-	1.17	PCFF65/12	420	420
1 1/2	38	34	30	89	107	36.5	79.3	16.7	M 16×55	5/8×2 1/4	1.62	PCFF66	420	420
2	51	46	37	116	135	44.5	96.8	20.6	M 20×70	3/4×2 3/4	3.40	PCFF68	420	420
2 1/2	64	56	45	150	166	58.7	123.8	25.0	M 24×90	-	6.77	PCFF610	420	420
3	76	81	55	178	208	71.4	152.4	32.0	M 30×110	-	12.36	PCFF612	420	420

**DB = 13.3 for UNC Bolts

***DB = 12 for UNC Bolts

¹⁾Pressure shown = Item deliverable

PN (bar) = PN (MPa)
10

Stainless steel parts may have dimensional deviations. Additional information on request.

*Please add the **suffixes** below according to the material/surface required.

Order code suffixes					
Material	Suffix surface and material	Example only closed flange	Example closed flange incl. metr. bolts and O-ring	Example closed flange incl. UNC bolts and O-ring	Standard sealing material (no additional suffix needed)
Steel, zinc plated, Cr(VI)-free	CF	PCFF32CF	PCFF32CFM	PCFF32CFU	NBR
Stainless steel	SS	PCFF32SS	PCFF32SSM	-	VIT

PCCFF SAE Closed counter flange

SAE Closed counter flange
(ISO 6162-1/-2)

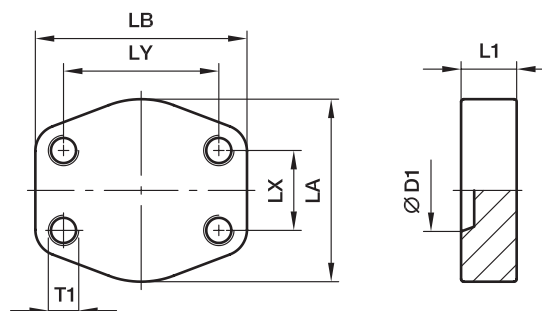

3000 PSI Series

Nom. flange size		D1	L1	LA	LB	LX	LY	T1		Weight (steel) kg/piece	Order code*	PN (bar) ¹⁾	
SAE (in.)	ISO (DN)							(metr.)	(unc.)			S	SS
1/2	13	13	16	47	58	17.5	38.1	M 8	5/16	0.26	PCCFF32	345	345
3/4	19	16	18	49	66	22.3	47.6	M10	3/8	0.37	PCCFF33	345	345
1	25	25	19	53	71	26.2	52.4	M10	3/8	0.45	PCCFF34	345	345
1 1/4	32	25	21	69	80	30.2	58.7	M10	7/16	0.73	PCCFF35	276	276
1 1/2	38	34	25	77	95	35.7	69.9	M12	1/2	1.50	PCCFF36	207	207
2	51	43	25	89	103	42.9	77.8	M12	1/2	1.40	PCCFF38	207	207
2 1/2	64	61	25	101	116	50.8	88.9	M12	1/2	1.83	PCCFF310	172	172
3	76	60	27	124	136	61.9	106.4	M16	5/8	2.80	PCCFF312	138	138
3 1/2	89	73	27	136	152	69.9	120.7	M16	5/8	3.68	PCCFF314	34	34
4	102	87	27	146	162	77.8	130.2	M16	5/8	4.10	PCCFF316	34	34
5	127	127	25	180	184	92.1	152.4	M16	5/8	6.40	PCCFF320	34	34

6000 PSI Series

1/2	13	13	16	47	58	18.2	40.5	M 8	5/16	0.30	PCCFF62	420	420
3/4	19	20	19	53	71	23.8	50.8	M10	3/8	0.49	PCCFF63	420	420
1	25	25	24	66	80	27.8	57.2	M12	7/16	0.82	PCCFF64	420	420
1 1/4	32	25	27	77	94	31.8	66.6	M14	1/2	1.22	PCCFF65	420	420
1 1/4	32	25	27	77	94	31.8	66.6	M12	–	1.22	PCCFF65/12	420	420
1 1/2	38	34	30	89	103	36.5	79.3	M16	5/8	1.69	PCCFF66	420	420
2	51	46	37	123	135	44.5	96.8	M20	3/4	3.48	PCCFF68	420	420
2 1/2	64	56	45	150	166	58.7	123.8	M24	–	7.08	PCCFF610	420	420
3	76	71	55	178	208	71.4	152.4	M30	–	12.67	PCCFF612	420	420

¹⁾ Pressure shown = Item deliverable

$\frac{PN \text{ (bar)}}{10} = PN \text{ (MPa)}$

Stainless steel parts may have dimensional deviations. Additional information on request.

*Please add the **suffixes** below according to the material/surface required.

Order code suffixes				
Material	Suffix surface and material	Example closed flange with metr. threads	Example closed flange with UNC threads	Standard sealing material (no additional suffix needed)
Steel, zinc plated, Cr(VI)-free	CF	PCCF32CFM	PCCFF32CFU	NBR
Stainless steel	SS	PCCFF32SSM	PCCFF32SSU	VIT

CPM SAE Flange connector plate

ISO 6162-1/-2

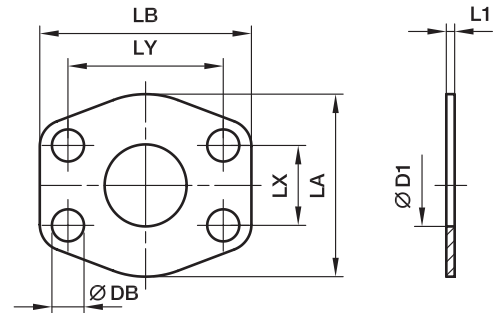

3000 PSI Series

Nom. flange size		D1	L1	LA	LB	LX	LY	DB	Weight (steel) kg/piece	Order code*	PN (bar) ¹⁾	
SAE (in.)	ISO (DN)										CF	SS
1/2	13	13	3	47	57	17.5	38.1	9.0	0.05	8CPM1	345	345
3/4	19	19	3	49	66	22.3	47.6	11.0	0.05	12CPM1	345	345
1	25	25	3	53	71	26.2	52.4	11.0	0.07	16CPM1	345	345
1 1/4	32	32	3	69	80	30.2	58.7	11.5	0.09	20CPM1	276	276
1 1/2	38	38	3	77	95	35.7	69.9	13.5	0.12	24CPM1	207	207
2	51	51	3	89	103	42.9	77.8	13.5	0.13	32CPM1	207	207
2 1/2	64	63	3	101	116	50.8	88.9	13.5	0.15	40CPM1	172	172
3	76	73	4	124	136	61.9	106.4	17.0	0.29	48CPM1	138	138
3 1/2	89	89	4	136	152	69.9	120.7	17.0	0.34	56CPM1	34	34
4	102	99	4	146	162	77.8	130.2	17.0	0.46	64CPM1	34	34
5	127	120	4	180	184	92.1	152.4	17.0	0.50	80CPM1	34	34

6000 PSI Series

1/2	13	13	4	47	57	18.2	40.5	9.0	0.08	8CPM2	420	420
3/4	19	17	4	53	71	23.8	50.8	11.0	0.11	12CPM2	420	420
1	25	24	4	66	80	27.8	57.2	13.0	0.14	16CPM2	420	420
1 1/4	32	31	4	77	94	31.8	66.6	15.0	0.20	20CPM2	420	420
1 1/2	38	38	4	89	103	36.5	79.3	17.0	0.24	24CPM2	420	420
2	51	51	4	123	135	44.5	96.8	21.0	0.30	32CPM2	420	420
2 1/2	64	63	4	150	166	58.7	123.8	25.0	0.50	40CPM2	420	420
3	76	73	4	178	208	71.4	152.4	32.0	0.73	48CPM2	420	420

¹⁾Pressure shown = Item deliverable

$$\frac{PN \text{ (bar)}}{10} = PN \text{ (MPa)}$$

Stainless steel parts may have dimensional deviations. Additional information on request.

*Please add the **suffixes** below according to the material/surface required.

Order code suffixes			
Material	Suffix surface and material	Example	Description
Steel, zinc plated, Cr(VI)-free	CF	8CPM1CF	only connector plate
Stainless steel	SS	8CPM1SS	only connector plate

AP SAE Flange locking plate

ISO 6162-1/-2

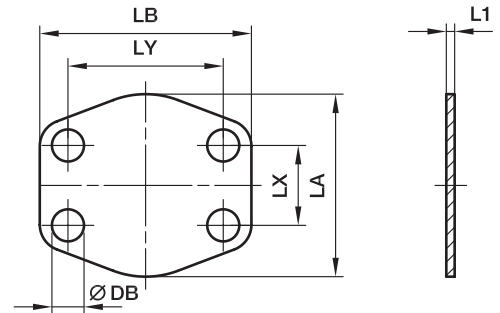

3000 PSI Series

Nom. flange size		L1	LA	LB	LX	LY	DB	Weight (steel) kg/piece	Order code*	PN (bar)	
SAE (in.)	ISO (DN)									CF	SS
1/2	13	3	47	57	17.5	38.1	9.0	0.05	8AP1	-	-
3/4	19	3	49	66	22.3	47.6	11.0	0.06	12AP1	-	-
1	25	3	59	71	26.2	52.4	11.0	0.07	16AP1	-	-
1 1/4	32	3	69	80	30.2	58.7	11.5	0.10	20AP1	-	-
1 1/2	38	3	77	95	35.7	69.9	13.5	0.15	24AP1	-	-
2	51	3	97	103	42.9	77.8	13.5	0.19	32AP1	-	-
2 1/2	64	3	109	116	50.8	89.9	13.5	0.22	40AP1	-	-
3	76	4	131	136	61.9	106.4	17.0	0.40	48AP1	-	-
3 1/2	89	4	136	152	69.9	102.7	17.0	0.53	56AP1	-	-
4	102	4	146	162	77.8	130.2	17.0	0.61	64AP1	-	-
5	127	4	181	184	92.1	152.4	17.0	0.86	80AP1	-	-

6000 PSI Series

1/2	13	4	48	57	18.2	40.5	9.0	0.02	8AP2	-	-
3/4	19	4	60	71	23.8	50.8	11.0	0.10	12AP2	-	-
1	25	4	70	81	27.8	57.2	13.0	0.12	16AP2	-	-
1 1/4	32	4	78	95	31.8	66.6	15.0	0.17	20AP2	-	-
1 1/2	38	4	95	113	36.5	79.4	17.0	0.22	24AP2	-	-
2	51	4	117	135	44.5	96.8	21.0	0.36	32AP2	-	-
2 1/2	64	4	150	176	58.7	123.8	25.0	0.58	40AP2	-	-
3	76	4	178	210	71.4	152.4	32.0	0.86	48AP2	-	-

This flange locking plate is not used under pressure.

Stainless steel parts may have dimensional deviations. Additional information on request.

*Please add the **suffixes** below according to the material/surface required.

Order code suffixes			
Material	Suffix surface and material	Example	Description
Steel, zinc plated, Cr(VI)-free	CF	8AP1CF	only locking plate
Stainless steel	SS	8AP1SS	only locking plate

PFMQ Flange head plug flat

(ISO 6162-1/-2)

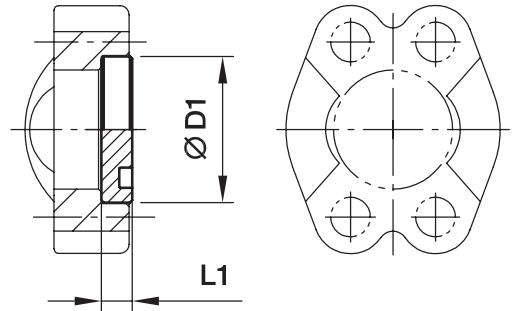

3000 PSI Series

Nom. flange size SAE (in.)	D1 	L1	Weight (steel) kg/piece	O-ring face Order code*	PN (bar) ¹⁾ CF
1/2	30.2	6.8	0.03	8PFMQ1	210
3/4	38.1	6.8	0.05	12PFMQ1	210
1	44.5	8.0	0.09	16PFMQ1	210
1 1/4	50.8	8.0	0.12	20PFMQ1	210
1 1/2	60.3	8.0	0.17	24PFMQ1	160
2	71.4	9.6	0.29	32PFMQ1	200
2 1/2	84.1	9.6	0.39	40PFMQ1	-
3	101.6	9.6	0.58	48PFMQ1	-
3 1/2	114.3	11.3	0.86	56PFMQ1	-
4	127.0	11.3	1.09	64PFMQ1	-
5	152.4	11.3	1.96	80PFMQ1	-

6000 PSI Series

1/2	31.8	7.8	0.04	8PFMQ2	250
3/4	41.3	8.8	0.09	12PFMQ2	250
1	47.6	9.5	0.13	16PFMQ2	250
1 1/4	54.0	10.3	0.18	20PFMQ2	250
1 1/2	63.5	12.6	0.30	24PFMQ2	250
2	79.4	12.6	0.48	32PFMQ2	250
2 1/2	107.7	20.5	1.44	40PFMQ2	-
3	131.7	26.0	2.75	48PFMQ2	-

1) Pressure shown = Item deliverable

$$\frac{\text{PN (bar)}}{10} = \text{PN (MPa)}$$

Flange head plug in stainless steel on request.

 *Please add the **suffixes** below according to the material/surface required.

Order code suffixes			
Material	Suffix surface and material	Example	Description
Steel, zinc plated, Cr(VI)-free	CF	8PFMQ1CF	only flange head plug

PMQ Flange head plug

(ISO 6162-1/-2)

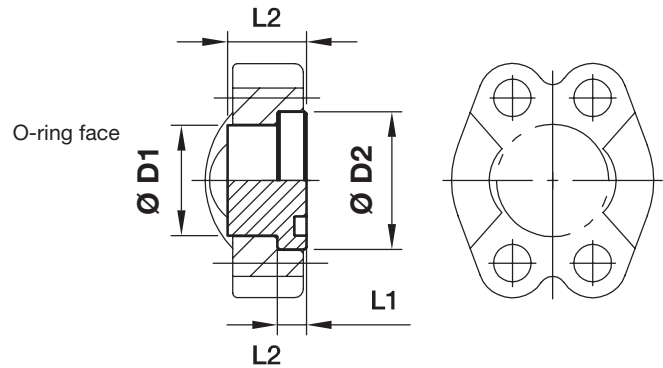

3000 PSI Series

Nom. flange size SAE (in.)	D1	D2	L1	L2	Weight (steel) kg/piece	O-ring face Order code	Flat face Order code	PN (bar) ¹⁾ CF
1/2	24.0	30.2	6.8	16	0.06	8PMQ1	8PCMQ1	350
3/4	31.8	38.1	6.8	17	0.12	12PMQ1	12PCMQ1	350
1	38.0	44.5	8.0	17	0.16	16PMQ1	16PCMQ1	315
1 1/4	43.0	50.8	8.0	17	0.22	20PMQ1	20PCMQ1	250
1 1/2	50.0	60.3	8.0	19	0.33	24PMQ1	24PCMQ1	200
2	62.0	71.4	9.6	19	0.51	32PMQ1	32PCMQ1	200
2 1/2	74.0	84.1	9.6	40	1.42	40PMQ1	40PCMQ1	160
3	90.0	101.6	9.6	45	2.35	48PMQ1	48PCMQ1	138
3 1/2	102.0	114.3	11.3	30	2.62	56PMQ1	56PCMQ1	35
4	114.5	127.0	11.3	36	3.14	64PMQ1	64PCMQ1	35
5	140.0	152.4	11.3	45	5.12	80PMQ1	80PCMQ1	35

6000 PSI Series

1/2	24.0	31.8	7.8	14	0.07	8PMQ2	8PCMQ1	400
3/4	31.8	41.3	8.8	15	0.12	12PMQ2	12PCMQ1	400
1	38.0	47.6	9.5	16	0.18	16PMQ2	16PCMQ1	400
1 1/4	44.0	54.0	10.3	16	0.24	20PMQ2	20PCMQ1	400
1 1/2	50.8	63.5	12.6	19	0.40	24PMQ2	24PCMQ1	400
2	67.0	79.4	12.6	30	0.95	32PMQ2	32PCMQ1	400
2 1/2	89.0	108.0	21.2	45	2.67	40PMQ2	40PCMQ1	400
3	114.3	132.0	26.5	55	5.11	48PMQ2	48PCMQ1	400

¹⁾Pressure shown = Item deliverable

$$\frac{PN \text{ (bar)}}{10} = PN \text{ (MPa)}$$

Flange head plug in stainless steel on request.

Please add the **suffixes** below according to the material/surface required.

Order code suffixes			
Material	Suffix surface and material	Example	Description
Steel, zinc plated, Cr(VI)-free	CF	8PMQ1CF	only flange head plug

PAGL-(G/M) SAE 4 bolt flange with test point port

SAE Flange with test point port
(ISO 6162-1/-2)

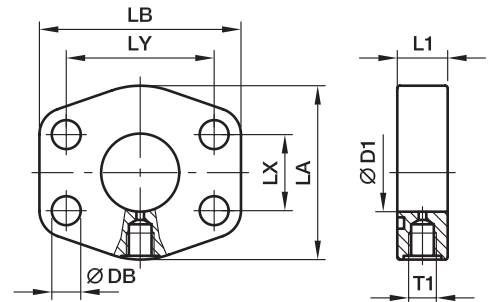

3000 PSI Series

Nom. flange size		T1	D1	L1	LA	LB	LX	LY	DB	Weight (steel) kg/piece	Order code*	PN (bar ¹⁾)	
SAE (in.)	ISO (DN)											S	SS
1	25	G 1/4	25	22	53	71	26.2	52.4	10.6	0.43	PAGL102G14	348	348
1	25	M 10x1.0	25	19	53	71	26.2	52.4	10.6	0.50	PAGL102M10	348	348
1 1/4	32	G 1/4	31	20	69	82	30.2	58.7	10.6	0.56	PAGL104G14	278	278
1 1/4	32	M 10x1.0	31	20	69	82	30.2	58.7	10.6	0.55	PAGL104M10	278	278
1 1/2	38	G 1/4	38	25	77	94	35.7	69.9	13.3	0.86	PAGL106G14	210	210
1 1/2	38	M 10x1.0	38	25	77	94	35.7	69.9	13.3	0.90	PAGL106M10	210	210
2	51	G 1/4	50	25	89	103	42.9	77.8	13.3	0.95	PAGL108G14	210	210
2	51	M 10x1.0	50	25	89	103	42.9	77.8	13.3	0.96	PAGL108M10	210	210
2 1/2	64	G 1/4	63	25	101	115	50.8	88.9	13.3	1.21	PAGL110G14	175	175
2 1/2	64	M 10x1.0	63	25	101	115	50.8	88.9	13.3	1.23	PAGL110M10	175	175
3	76	G 1/4	73	27	124	135	61.9	106.4	16.7	2.00	PAGL112G14	138	138
3	76	M 10x1.0	73	27	124	135	61.9	106.4	16.7	2.01	PAGL112M10	138	138
3 1/2	89	G 1/4	89	27	136	152	69.9	120.7	16.7	2.42	PAGL114G14	35	35
3 1/2	89	M 10x1.0	89	27	136	152	69.9	120.7	16.7	2.43	PAGL114M10	35	35
4	102	G 1/4	99	27	146	162	77.8	130.2	16.7	2.73	PAGL116G14	35	35
4	102	M 10x1.0	99	27	146	162	77.8	130.2	16.7	2.73	PAGL116M10	35	35
5	127	G 1/4	120	28	180	184	92.1	152.4	16.7	3.76	PAGL118G14	35	35
5	127	M 10x1.0	120	28	180	184	92.1	152.4	16.7	3.76	PAGL118M10	35	35

6000 PSI Series

1	25	G 1/4	25	22	69	82	27.8	57.2	13.3	0.65	PAGL403G14	420	420
1	25	M 10x1.0	25	22	69	82	27.8	57.2	13.3	0.65	PAGL403M10	420	420
1 1/4	32	G 1/4	31	26	79	96	31.8	66.6	15.0	0.95	PAGL404G14	420	420
1 1/4	32	G 1/4	31	26	79	96	31.8	66.6	13.3	0.95	PAGL404/12G14	420	420
1 1/4	32	M 10x1.0	31	26	79	96	31.8	66.6	15.0	0.95	PAGL404M10	420	420
1 1/4	32	M 10x1.0	31	26	79	96	31.8	66.6	13.3	0.95	PAGL404/12M10	420	420
1 1/2	38	G 1/4	38	30	89	108	36.5	79.3	16.7	1.37	PAGL405G14	420	420
1 1/2	38	M 10x1.0	38	30	89	108	36.5	79.3	16.7	1.37	PAGL405M10	420	420
2	51	G 1/4	50	36	116	135	44.5	96.8	20.6	2.84	PAGL406G14	420	420
2	51	M 10x1.0	50	36	116	135	44.5	96.8	20.6	2.84	PAGL406M10	420	420
2 1/2	64	G 1/4	63	45	150	166	58.7	123.8	25.0	5.90	PAGL408G14	420	420
2 1/2	64	M 10x1.0	63	45	150	166	58.7	123.8	25.0	5.90	PAGL408M10	420	420
3	76	G 1/4	73	55	178	208	71.4	152.4	31.0	8.50	PAGL410G14	420	420
3	76	M 10x1.0	73	55	178	208	71.4	152.4	31.0	8.50	PAGL410M10	420	420

¹⁾ Pressure shown = Item deliverable

$\frac{\text{PN (bar)}}{10} = \text{PN (MPa)}$

Stainless steel parts may have dimensional deviations. Additional information on request.

*Please add the **suffixes** below according to the material/surface required.

Order code suffixes			
Material	Suffix surface and material	Example	Description
Steel, zinc plated, Cr(VI)-free	CF	PAGL102G14CF	only flange
Stainless steel	SS	PAGL102G14SS	only flange

PRF SAE Straight reducing flange adapter

ISO 6162-1/-2

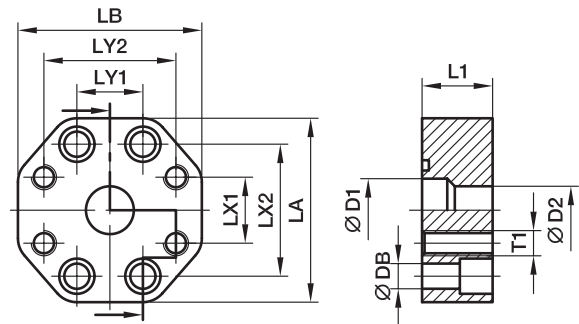

3000 PSI Series

Nom. flange size		D1	D2	L1	LA	LB	LX1	LX2	LY1	LY2	DB	Bolts (metr.)	T1	Weight (steel) kg/piece	Order code*	PN (bar) ¹⁾ S
SAE (in.)	ISO (DN)															
1x1	25/25	25	25	28	73	73	26.2	52.4	26.2	52.4	10.6	M 10x30	M10	0.75	PRF102/102	210
1x3/4	25/19	25	19	28	73	73	22.3	52.4	26.2	47.6	10.6	M 10x30	M10	0.76	PRF102/100	210
1 1/4x1 1/4	32/32	30	30	28	80	80	30.2	58.7	30.2	58.7	10.6	M 10x30	M10	0.83	PRF104/104	210
1 1/4x1	32/25	30	25	28	80	71	26.2	58.7	30.2	52.4	10.6	M 10x30	M10	0.95	PRF104/102	210
1 1/2x1 1/2	38/38	38	38	32	94	94	35.7	69.9	35.7	69.9	13.3	M 12x35	M12	1.20	PRF106/106	210
1 1/2x1 1/4	38/32	38	30	32	94	80	30.2	69.9	35.7	58.7	13.3	M 12x35	M10	1.36	PRF106/104	210
2x2	51/51	50	50	33	103	103	42.9	77.8	42.9	77.8	13.3	M 12x35	M12	1.56	PRF108/108	210
2x1 1/2	51/38	50	38	33	103	94	35.7	77.8	42.9	70.0	13.3	M 12x35	M12	1.69	PRF108/106	210
2 1/2x2 1/2	64/64	63	63	33	115	115	50.8	88.9	50.8	88.9	13.3	M 12x35	M12	2.05	PRF110/110	175
2 1/2x2	64/51	63	50	33	115	103	42.9	88.9	50.8	77.8	13.3	M 12x35	M12	2.04	PRF110/108	175
3x3	76/76	73	73	36	135	135	61.9	106.4	61.9	106.4	16.7	M 16x40	M16	2.61	PRF112/112	138
3x2 1/2	76/64	73	63	36	135	115	50.8	106.4	61.9	89.0	16.7	M 16x40	M12	2.61	PRF112/110	138

6000 PSI Series

3/4x3/4	19/19	19	19	28	73	73	23.8	50.8	23.8	50.8	10.6	M 10x30	M10	0.80	PRF402/402	420
1x1	25/25	25	25	33	80	80	27.8	57.2	27.8	57.2	13.3	M 12x35	M12	1.03	PRF403/403	420
1x3/4	25/19	25	19	33	80	71	23.8	57.2	27.8	50.8	13.3	M 12x35	M10	0.98	PRF403/402	420
1 1/4x1 1/4	32/32	30	30	33	94	94	31.8	66.6	31.8	66.6	15.0	M 14x35	M14	1.47	PRF404/404	420
1 1/4x1 1/4	32/32	30	30	33	94	94	31.8	66.6	31.8	66.6	13.3	M 12x35	M12	1.47	PRF404/12/404/12	420
1 1/4x1	32/25	30	25	33	94	80	27.8	66.6	31.8	57.2	15.0	M 14x35	M12	1.26	PRF404/403	420
1 1/4x1	32/25	30	25	33	94	80	27.8	66.6	31.8	57.2	13.3	M 12x35	M12	1.26	PRF404/12/403	420
1 1/2x1 1/2	38/38	38	38	48	106	106	36.5	79.3	36.5	79.3	16.7	M 16x50	M16	1.72	PRF405/405	420
1 1/2x1 1/4	38/32	38	30	48	106	94	31.8	79.3	36.5	66.6	16.7	M 16x50	M14	2.32	PRF405/404	420
1 1/2x1 1/4	38/32	38	30	48	106	94	31.8	79.3	36.5	66.6	16.7	M 16x50	M12	2.32	PRF405/404/12	420
2x2	51/51	50	50	48	135	135	44.5	96.8	44.5	96.8	20.6	M 20x55	M20	4.20	PRF406/406	420
2x1 1/2	51/38	50	38	48	135	106	36.5	96.8	44.5	79.3	20.6	M 20x55	M16	3.35	PRF406/405	420
2 1/2x2	64/64	63	63	53	166	166	50.8	123.8	50.8	123.8	25.0	M 24x60	M24	6.40	PRF408/408	420
3x2	76/51	73	50	58	208	178	44.5	152.4	71.4	96.8	31.0	M 30x70	M20	10.40	PRF410/406	420

¹⁾Pressure shown = Item deliverable

$$\frac{PN \text{ (bar)}}{10} = PN \text{ (MPa)}$$

Stainless steel parts may have dimensional deviations. Additional information on request.

*Please add the **suffixes** below according to the material/surface required.

Order code suffixes			
Material	Suffix surface and material	Example	Description
Steel, zinc plated, Cr(VI)-free	CF	PRF102/102CF	only flange
Stainless steel	SS	PRF102/102SS	only flange

BFG Gear pump flange straight

Hydraulic flange / EO 24° cone end

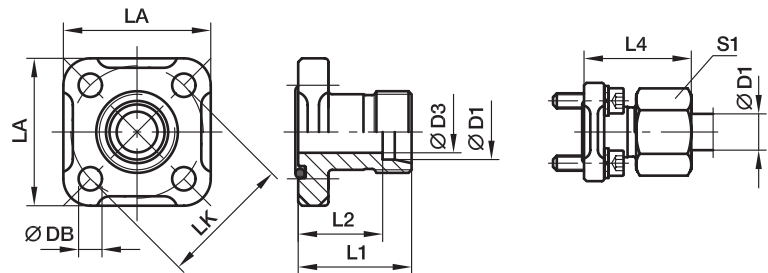

BFG Straight flange connection EO 24° cone end

LK	D1 ²⁾	D3	L1	L2	L4	LA	S1	DB	Bolts (metr.)	O-ring	Weight (steel) kg/piece	Order code*	PN (bar) ¹⁾ CF
35	10L	8	30	23.0	39.0	40	19	6.4	M 06×22	20×2.5	0.15	BFG10L/LK35	315
35	12L	10	30	23.0	39.0	40	22	6.4	M 06×22	20×2.5	0.16	BFG12L/LK35	315
35	15L	12	30	23.0	38.0	40	27	6.4	M 06×22	20×2.5	0.19	BFG15L/LK35	250
35	16S	12	30	21.5	39.5	40	30	6.4	M 06×22	20×2.5	0.21	BFG16S/LK35	315
40	15L	12	35	28.0	43.0	42	27	6.4	M 06×22	26×2.5	0.17	BFG15L/LK40	100
40	18L	15	35	27.5	44.0	42	32	6.4	M 06×22	26×2.5	0.22	BFG18L/LK40	100
40	22L	19	35	27.5	44.5	42	36	6.4	M 06×22	26×2.5	0.26	BFG22L/LK40	100
40	28L	24	42	34.5	51.5	42	41	6.4	M 06×22	26×2.5	0.30	BFG28L/LK40	100
55	20S	16	40	29.5	51.0	55	36	8.4	M 08×25	32×2.5	0.49	BFG20S/LK55	250

¹⁾ Pressure shown = Item deliverable

²⁾ L = light series; S = heavy series

$$\frac{\text{PN (bar)}}{10} = \text{PN (MPa)}$$

Delivery without nut and ring.
Information on ordering complete fittings
or alternative sealing materials see page N12.

*Please add the **suffixes** below according to the material/surface required.

Order code suffixes			
Material	Suffix surface and material	Example incl. metr. bolts and O-ring	Standard sealing material (no additional suffix needed)
Steel, zinc plated, Cr(VI)-free	CF	BFG16S/LK35OMDCF	NBR

BFW Gear pump flange 90° elbow

Hydraulic flange / EO 24° cone end

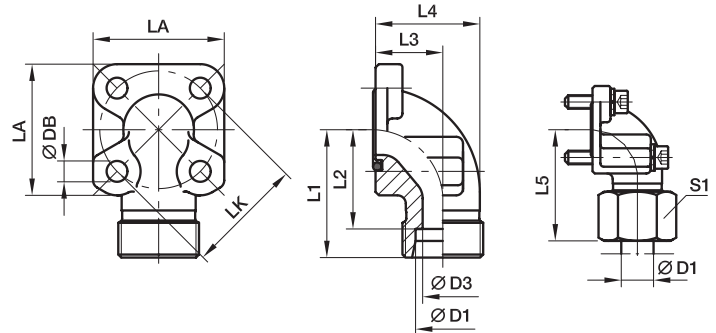

BFW 90° Flange connection EO 24° cone end

LK	D1 ²⁾	D3	L1	L2	L3	L4	L5	LA	S1	DB	Bolts		O-ring	Weight (steel) kg/piece	Order code*	PN (bar) ¹⁾ CF
											2 pieces (metr.)	2 pieces (metr.)				
35	10L	8	38	31.0	16.5	26.5	47.0	40	19	6.4	M 06×22	M 06×35	20×2.5	0.23	BFW10L/LK35	315
35	12L	10	38	31.0	16.5	26.5	47.0	40	22	6.4	M 06×22	M 06×35	20×2.5	0.26	BFW12L/LK35	315
35	15L	12	38	31.0	16.5	26.5	46.0	40	27	6.4	M 06×22	M 06×35	20×2.5	0.26	BFW15L/LK35	250
35	16S	12	38	29.5	20.0	31.0	48.0	40	30	6.4	M 06×22	M 06×40	20×2.5	0.30	BFW16S/LK35	315
35	20S	16	45	34.5	25.0	38.0	56.0	40	36	6.4	M 06×22	M 06×45	20×2.5	0.40	BFW20S/LK35	315
35	22L	19	45	37.5	25.0	38.0	54.5	40	36	6.4	M 06×22	M 06×45	20×2.5	0.25	BFW22L/LK35	250
40	15L	12	38	31.0	22.5	36.5	46.0	42	27	6.4	M 06×22	M 06×22	26×2.5	0.23	BFW15L/LK40	100
40	18L	15	38	30.5	22.5	36.5	47.0	42	32	6.4	M 06×22	M 06×22	26×2.5	0.30	BFW18L/LK40	100
40	22L	19	38	30.5	22.5	36.5	47.5	42	36	6.4	M 06×22	M 06×22	26×2.5	0.30	BFW22L/LK40	100
40	28L	22	40	32.5	28.0	43.0	49.0	42	41	6.4	M 06×20	M 06×50	26×2.5	0.40	BFW28L/LK40	100
40	35L	31	41	30.5	34.0	55.0	52.0	42	50	6.4	M 06×22	M 06×60	26×2.5	0.35	BFW35L/LK40	100
40	20S	16	40	29.5	22.5	35.5	50.0	42	36	6.4	M 06×22	M 06×45	26×2.5	0.35	BFW20S/LK40	250
55	35L	31	49	38.5	32.0	51.5	62.0	58	50	8.4	M 08×25	M 08×60	32×2.5	0.74	BFW35L/LK55	100
55	42L	38	49	38.0	40.0	64.5	61.0	58	60	8.4	M 08×25	M 08×70	32×2.5	0.60	BFW42L/LK55	100
55	20S	17	45	34.5	24.0	38.0	56.0	58	36	8.4	M 08×25	M 08×50	32×2.5	0.64	BFW20S/LK55	250
55	25S	20	49	37.0	30.0	46.0	61.0	58	46	8.4	M 08×25	M 08×55	32×2.5	0.80	BFW25S/LK55	250
55	30S	26	49	35.5	32.0	50.0	62.0	58	50	8.4	M 08×25	M 08×50	32×2.5	0.81	BFW30S/LK55	250

¹⁾Pressure shown = Item deliverable

²⁾L = light series; S = heavy series

$$\frac{PN \text{ (bar)}}{10} = PN \text{ (MPa)}$$

Delivery without nut and ring.

Information on ordering complete fittings or alternative sealing materials see page N12.

*Please add the **suffixes** below according to the material/surface required.

Order code suffixes			
Material	Suffix surface and material	Example incl. metr. bolts and O-ring	Standard sealing material (no additional suffix needed)
Steel, zinc plated, Cr(VI)-free	CF	BFW16S/LK35OMDCF	NBR

BFW3 Gear pump flange 90° elbow 3 holes

Hydraulic flange / EO 24° cone end

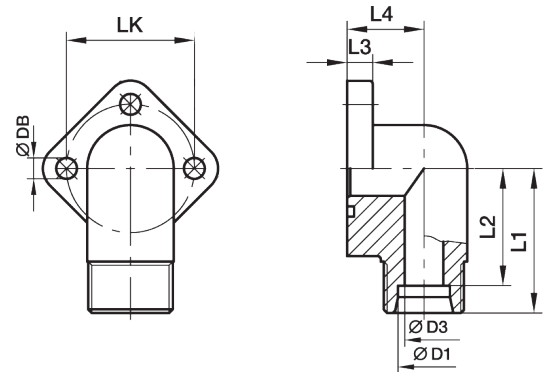

BFW-3 90° Flange connection EO 24° cone end

LK	D1 ²⁾	D3	L1	L2	L3	L4	DB	Bolts (metr.)	O-ring	Weight (steel) kg/piece	Order code*	PN (bar) ¹⁾ CF
30	12L	9	31	24.0	9.0	17.0	6.5	M 06x22	16x2.5	0.20	BFW3-12L/LK30	250
30	15L	11	31	24.0	9.0	17.0	6.5	M 06x22	16x2.5	0.22	BFW3-15L/LK30	250
30	18L	12	31	23.5	9.0	17.0	6.5	M 06x22	16x2.5	0.25	BFW3-18L/LK30	160
40	22L	18	36	28.5	11.5	23.0	8.5	M 08x30	24x2.5	0.44	BFW3-22L/LK40	160
40	28L	19	36	28.5	11.5	23.0	8.5	M 08x30	24x2.5	0.45	BFW3-28L/LK40	160

¹⁾ Pressure shown = Item deliverable

²⁾ L = light series

$\frac{PN \text{ (bar)}}{10} = PN \text{ (MPa)}$

Delivery without nut and ring.

Information on ordering complete fittings
or alternative sealing materials see page N12.

*Please add the **suffixes** below according to the material/surface required.

Order code suffixes			
Material	Suffix surface and material	Example incl. metr. bolts and O-ring	Standard sealing material (no additional suffix needed)
Steel, zinc plated, Cr(VI)-free	CF	BFW3-12L/LK30OMDCF	NBR

BFGL Gear pump flange straight

Hydraulic flange / O-Lok®-connection straight

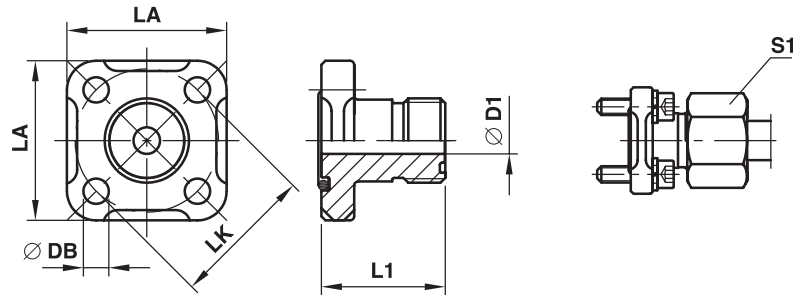

BFGL Straight flange connection O-Lok® end

LK	D1	S1	Thread UN/UNF T1	L1	LA	DB	Bolts (metr.)	O-ring 1	O-ring 2	Weight (steel) kg/piece	Order code*	PN (bar) ¹⁾ CF
35	6.5	10L	11/16-16	30	40	6.4	M 06×22	20×2.5	9.25×1.78	0.09	6BFGL/LK35	315
35	9.5	12L	13/16-16	30	40	6.4	M 06×22	20×2.5	12.42×1.78	0.10	8BFGL/LK35	315
35	12.5	15L	1-14	30	40	6.4	M 06×22	20×2.5	15.60×1.78	0.10	10BFGL/LK35	250
40	12.5	15L	1-14	35	42	6.4	M 06×22	26×2.5	15.60×1.78	0.10	10BFGL/LK40	100
40	15.5	18L	1 3/16-12	35	42	6.4	M 06×22	26×2.5	18.77×1.78	0.16	12BFGL/LK40	100
40	20.5	28L	1 7/16-12	35	42	6.4	M 06×22	26×2.5	23.52×1.78	0.17	16BFGL/LK40	100

¹⁾Pressure shown = Item deliverable

$$\frac{PN \text{ (bar)}}{10} = PN \text{ (MPa)}$$

Delivery without nut and ring.

Information on ordering complete fittings or alternative sealing materials see page N12.

*Please add the **suffixes** below according to the material/surface required.

Order code suffixes			
Material	Suffix surface and material	Example incl. metr. bolts and O-ring	Standard sealing material (no additional suffix needed)
Steel, zinc plated, Cr(VI)-free	CF	6BFGL/LK35OMDCF	NBR

BFWL Gear pump flange 90° elbow

Hydraulic flange / O-Lok®-connection – 90°

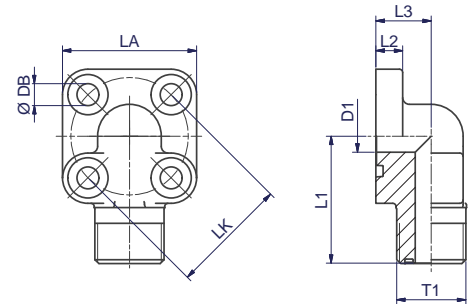

BFWL-90° O-Lok®-connection

LK	D1	Thread UN/UNF T1	L1	L2	L3	LA	DB	Bolts		O-ring 1	O-ring 2	Weight kg/piece	Order code	PN (bar) ¹⁾ CF
								2 pieces (metr.)	2 pieces (metr.)					
35	6.5	11/16-16	38	8	16.5	40	6.5	M 06×22	M 06×35	20×2.5	9.25×1.78	0.16	6BFWL/LK35	315
35	9.5	13/16-16	38	8	16.5	40	6.5	M 06×22	M 06×35	20×2.5	12.42×1.78	0.16	8BFWL/LK35	315
35	12.5	1-14	38	8	20.0	40	6.5	M 06×22	M 06×40	20×2.5	15.60×1.78	0.19	10BFWL/LK35	250
40	12.5	1-14	40	8	22.5	42	6.5	M 06×22	M 06×40	26×2.5	15.60×1.78	0.16	10BFWL/LK40	100
40	15.5	1 3/16-12	45	8	24.0	42	6.5	M 06×22	M 06×45	26×2.5	18.77×1.78	0.20	12BFWL/LK40	250

¹⁾Pressure shown = Item deliverable

$\frac{PN \text{ (bar)}}{10} = PN \text{ (MPa)}$

Material: Steel

- Complete with O-ring and metric bolts
- Single part without accessories

*Please add the **suffixes** below according to the material/surface required.

Order code suffixes			
Material	Suffix surface and material	Example incl. metr. bolts and O-ring	Standard sealing material (no additional suffix needed)
Steel, zinc plated, Cr(VI)-free	CF	6BFWL/L/LK35CFM	NBR

BFW-G Gear pump flange 90° elbow

Hydraulic flange / BSPP 60° cone end
(ISO 8434-6)

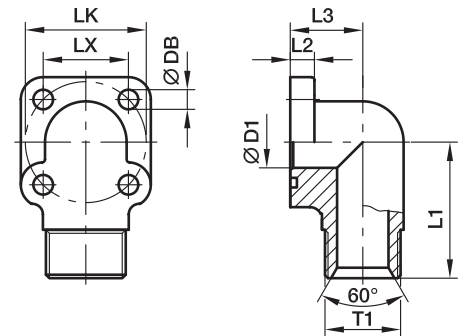

BFW-G 90° BSPP 60° cone end

LK	T1	D1	L1	L2	L3	LX	DB	Bolts		O-ring	Weight (steel) kg/piece	Order code*	PN (bar) ¹⁾ CF
								2 pieces (metr.)	2 pieces (metr.)				
35	G 3/8	10	40	8	20.0	24.8	6.5	M 06×20	M 06×35	18.72×2.62	0.20	BFW-G38/LK35	315
35	G 1/2	12	40	8	16.5	24.8	6.5	M 06×20	M 06×40	18.72×2.62	0.20	BFW-G12/LK35	315
35	G 3/4	12	40	8	20.0	24.8	6.5	M 06×20	M 06×40	18.72×2.62	0.25	BFW-G34/LK35	315
40	G 3/8	10	40	8	22.5	28.2	6.5	M 06×20	M 06×40	25.07×2.62	0.32	BFW-G38/LK40	250
40	G 1/2	12	45	8	24.0	28.2	6.5	M 06×20	M 06×40	25.07×2.62	0.26	BFW-G12/LK40	250
40	G 3/4	17	45	8	24.0	28.2	6.5	M 06×20	M 06×40	25.07×2.62	0.28	BFW-G34/LK40	250
40	G 1	19	40	8	28.0	28.2	6.5	M 06×20	M 06×50	25.07×2.62	0.30	BFW-G1/LK40	250
55	G 1/2	13	49	12	24.0	38.8	8.5	M 08×25	M 08×45	31.42×2.62	0.54	BFW-G12/LK55	315
55	G 3/4	17	46	12	31.0	38.8	8.5	M 08×25	M 08×60	31.42×2.62	0.48	BFW-G34/LK55	315
55	G 1	22	50	12	40.0	38.8	8.5	M 08×25	M 08×70	31.42×2.62	0.62	BFW-G1/LK55	315

¹⁾ Pressure shown = Item deliverable

$$\frac{\text{PN (bar)}}{10} = \text{PN (MPa)}$$

*Please add the **suffixes** below according to the material/surface required.

Order code suffixes			
Material	Suffix surface and material	Example incl. metr. bolts and O-ring	Standard sealing material (no additional suffix needed)
Steel, zinc plated, Cr(VI)-free	CF	BFW-G38/LK35CFM	NBR

BFW-GI Gear pump flange 90° elbow

Hydraulic flange / Female BSPP thread

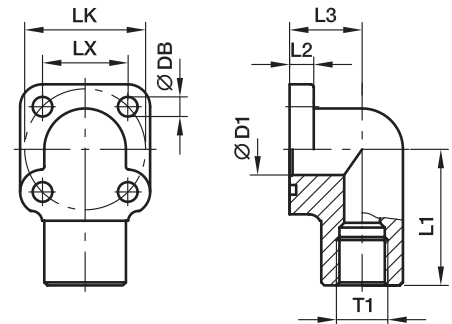

BFW-GI 90° Female BSPP thread

LK	T1	D1	L1	L2	L3	LX	DB	Bolts		O-ring	Weight (steel) kg/piece	Order code*	PN (bar) ¹⁾ CF
								2 pieces (metr.)	2 pieces (metr.)				
35	G 3/8	10	40	8	20.0	24.8	6.5	M 06×20	M 06×35	18.72×2.62	0.22	BFW-GI38/LK35	315
35	G 1/2	13	40	8	20.0	24.8	6.5	M 06×20	M 06×35	18.72×2.62	0.30	BFW-GI12/LK35	315
40	G 3/8	10	45	8	24.0	28.2	6.5	M 06×20	M 06×40	25.07×2.62	0.42	BFW-GI38/LK40	250
40	G 1/2	13	45	8	24.0	28.2	6.5	M 06×20	M 06×40	25.07×2.62	0.42	BFW-GI12/LK40	250
40	G 3/4	17	45	8	24.0	28.2	6.5	M 06×20	M 06×40	25.07×2.62	0.32	BFW-GI34/LK40	250
55	G 1/2	13	46	12	24.0	38.8	8.5	M 08×25	M 08×45	31.42×2.62	0.58	BFW-GI12/LK55	315
55	G 3/4	17	49	12	31.0	38.8	8.5	M 08×25	M 08×60	31.42×2.62	0.69	BFW-GI34/LK55	315
55	G 1	22	50	12	40.0	38.8	8.5	M 08×25	M 08×70	31.42×2.62	0.81	BFW-G 11/LK55	315

¹⁾Pressure shown = Item deliverable

$\frac{PN \text{ (bar)}}{10} = PN \text{ (MPa)}$

*Please add the **suffixes** below according to the material/surface required.

Order code suffixes			
Material	Suffix surface and material	Example incl. metr. bolts and O-ring	Standard sealing material (no additional suffix needed)
Steel, zinc plated, Cr(VI)-free	CF	BFW-GI38/LK35CFM	NBR

BFW-S Gear pump flange 90° elbow

Hydraulic flange / Socket weld end

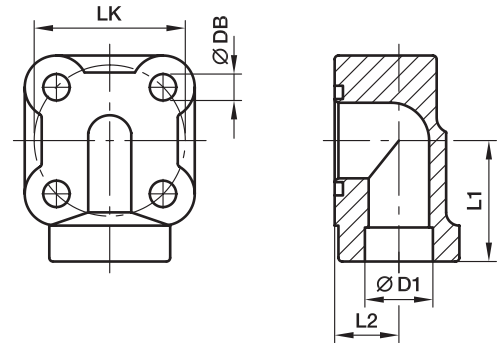

BFW-S 90° Socket weld end

LK	D1	L1	L2	DB	Bolts (metr.)	O-ring	Weight (steel) kg/piece	Order code*	PN (bar) ¹⁾ S
30	12	30	14	7.0	M 06×30	15.88×2.62	0.30	BFW-S12/LK30/M6	200
30	12	27	13	8.5	M 08×35	15.88×2.62	0.29	BFW-S12/LK30/M8	250
30	14	27	13	6.5	M 06×30	15.88×2.62	0.29	BFW-S14/LK30/M6	200
30	14	27	13	8.5	M 08×35	15.88×2.62	0.28	BFW-S14/LK30/M8	250
30	16	27	13	6.5	M 06×30	15.88×2.62	0.29	BFW-S16/LK30/M6	200
30	16	27	13	8.5	M 08×35	15.88×2.62	0.28	BFW-S16/LK30/M8	250
30	18	27	13	6.5	M 06×30	15.88×2.62	0.27	BFW-S18/LK30/M6	200
35	14	30	12	6.5	M 06×35	18.72×2.62	0.40	BFW-S14/LK35/M6	200
35	14	30	14	8.5	M 08×40	18.72×2.62	0.39	BFW-S14/LK35/M8	250
35	16	30	12	6.5	M 06×35	18.72×2.62	0.27	BFW-S16/LK35/M6	200
35	16	30	14	8.5	M 08×40	18.72×2.62	0.27	BFW-S16/LK35/M8	250
35	18	30	14	6.5	M 06×35	18.72×2.62	0.26	BFW-S18/LK35/M6	200
35	18	30	14	8.5	M 08×40	18.72×2.62	0.25	BFW-S18/LK35/M8	250
35	20	30	14	7.0	M 06×35	18.72×2.62	0.27	BFW-S20/LK35/M6	200
40	18	32	17	6.5	M 06×40	23.81×2.62	0.37	BFW-S18/LK40/M6	200
40	18	32	17	8.5	M 08×40	23.81×2.62	0.36	BFW-S18/LK40/M8	250
40	20	32	17	6.5	M 06×40	23.81×2.62	0.36	BFW-S20/LK40/M6	200
40	20	32	17	8.5	M 08×40	23.81×2.62	0.35	BFW-S20/LK40/M8	250
40	22	32	17	6.5	M 06×40	23.81×2.62	0.35	BFW-S22/LK40/M6	200
40	22	32	17	8.5	M 08×40	23.81×2.62	0.35	BFW-S22/LK40/M8	250
40	25	32	17	6.5	M 06×40	23.81×2.62	0.34	BFW-S25/LK40/M6	200
40	25	32	17	8.5	M 08×40	23.81×2.62	0.33	BFW-S25/LK40/M8	250

¹⁾Pressure shown = Item deliverable

$$\frac{PN \text{ (bar)}}{10} = PN \text{ (MPa)}$$

The pressures given here are the maximum allowable for the flange fittings. If the pipe or tube used has a lower pressure rating, then the welded assembly rating will be the lower one, assuming the weld is adequately strong.

*Please add the **suffixes** below according to the material/surface required.

Order code suffixes			
Material	Suffix surface and material	Example incl. metr. bolts and O-ring	Standard sealing material (no additional suffix needed)
Steel, blanc oil dipped	S	BFW-S16/LK30/M6SM	NBR

PF Gear pump flange straight

Hydraulic flange / Female BSPB thread

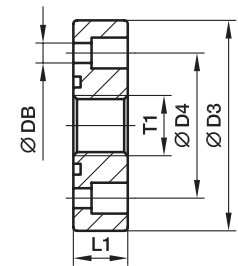

PF

Pump size	LK	T1	D3	D4	L1	DB	Bolts (metr.)	O-ring	Weight (steel) kg/piece	Order code*	PN (bar) ¹⁾ CF
1.0	30.0	G 3/8	45	30.0	13	6.5	M 06×16	18.77×1.78	0.15	PF1	315
2.0	40.0	G 1/2	58	40.0	15	8.5	M 08×20	25.12×1.78	0.29	PF2	315
3.0	51.0	G 3/4	75	51.0	18	10.5	M 10×25	31.42×2.62	0.58	PF3	315
3B	56.0	G 3/4	76	56.0	18	10.5	M 10×25	31.42×2.62	0.61	PF3B	315
3.5	62.0	G 1	88	62.0	20	10.5	M 10×25	39.69×3.53	0.84	PF3.5	315
3.5B	62.0	G 1	88	62.0	20	12.5	M 12×35	39.69×3.53	0.82	PF3.5B	315
4.0	72.5	G 1 1/4	98	72.5	22	12.5	M 12×30	47.22×3.53	1.06	PF4	315

PFL Gear pump flange straight

Hydraulic flange / Female BSBP thread – long version

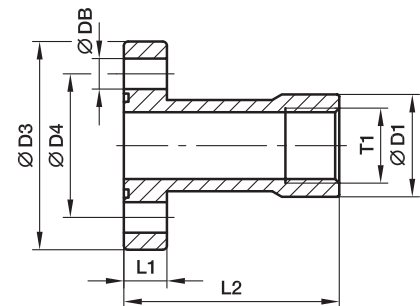

PFL

Pump size	LK	T1	D1	D3	D4	L1	L2	DB	Bolts (metr.)	O-ring	Weight (steel) kg/piece	Order code*	PN (bar) ¹⁾ CF
1.0	30.0	G 3/8	21.0	45	30.0	10	55	6.5	M 06×20	18.77×1.78	0.20	PFL1	315
2.0	40.0	G 1/2	26.5	58	40.0	12	60	8.5	M 08×25	25.12×1.78	0.39	PFL2	315
3.0	51.0	G 3/4	33.5	76	51.0	16	72	10.5	M 10×35	31.42×2.62	0.79	PFL3	315
3B	56.0	G 3/4	33.5	76	56.0	16	72	10.5	M 10×35	31.42×2.62	0.79	PFL3.5	315

¹⁾ Pressure shown = Item deliverable

$\frac{PN \text{ (bar)}}{10} = PN \text{ (MPa)}$

*Please add the **suffixes** below according to the material/surface required.

Order code suffixes			
Material	Suffix surface and material	Example incl. metr. bolts and O-ring	Standard sealing material (no additional suffix needed)
Steel, zinc plated, Cr(VI)-free	PF CF	PF1CFM	NBR
Steel, zinc plated, Cr(VI)-free	PFL CF	PFL1CFM	NBR

Gear pump flanges

PFE Gear pump flange straight

Hydraulic flange / BSPP 60° cone end
(ISO 8434-6)

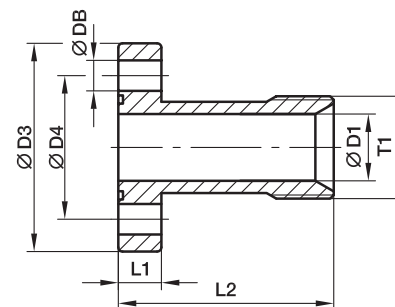

PFE

Pump size	LK	T1	D1	D3	D4	L1	L2	DB	Bolts (metr.)	O-ring	Weight (steel) kg/piece	Order code*	PN (bar) ¹⁾ CF
1.0	30.0	G 1/2	14.0	45	30.0	10	55	6.5	M 06×20	18.77×1.78	0.19	PFE1	315
2.0	40.0	G 3/4	19.0	58	40.0	12	60	8.5	M 08×25	25.12×1.78	0.37	PFE2	315
3.0	51.0	G 1	24.0	76	51.0	16	72	10.5	M 10×35	31.42×2.62	0.75	PFE3	315
3B	56.0	G 1	24.0	76	56.0	16	72	10.5	M 10×35	31.42×2.62	0.72	PFE3.5	315

PFB Gear pump flange straight

Hydraulic flange / Butt weld tube end

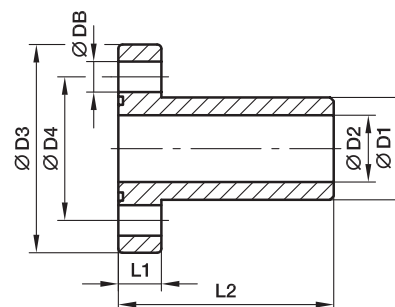

PFB

Pump size	LK	D1	D2	D3	D4	L1	L2	DB	Bolts (metr.)	O-ring	Weight (steel) kg/piece	Order code*	PN (bar) ¹⁾ S
1.0	30.0	19.0	14.0	45	30.0	10	55	6.5	M 06×20	18.77×1.78	0.19	PFB1	250
2.0	40.0	25.4	19.0	58	40.0	12	60	8.5	M 08×25	25.12×1.78	0.37	PFB2	250
3.0	51.0	32.0	24.5	76	51.0	16	72	10.5	M 10×35	31.42×2.62	0.78	PFB3	250
3B	56.0	32.0	24.5	76	56.0	16	72	10.5	M 10×35	31.42×2.62	0.74	PFB3.5	250

¹⁾ Pressure shown = Item deliverable

$\frac{PN \text{ (bar)}}{10} = PN \text{ (MPa)}$

The pressures (PFB) given here are the maximum allowable for the flange fittings. If the pipe or tube used has a lower pressure rating, then the welded assembly rating will be the lower one, assuming the weld is adequately strong.

*Please add the **suffixes** below according to the material/surface required.

Order code suffixes			
Material	Suffix surface and material	Example incl. metr. bolts and O-ring	Standard sealing material (no additional suffix needed)
Steel, zinc plated, Cr(VI)-free	PFE CF	PFE1CFM	NBR
Steel, blanc oil dipped	PFB S	PFB1SM	NBR

BFW3-G Gear pump flange 90° elbow 3 holes

Hydraulic flange / Female BSPP thread

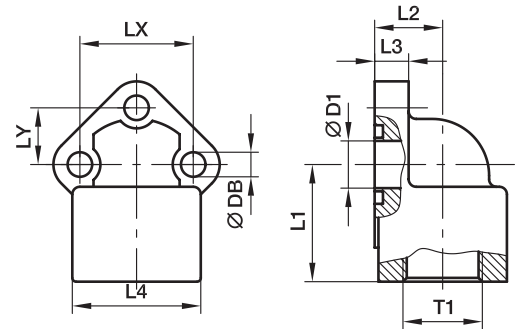

PWDS Female BSPP thread

Pump size	LK	T1	D1	L1	L2	L3	L4	LX	LY	DB	Bolts (metr.)	O-ring	Weight (steel) kg/piece	Order code*	PN (bar) ¹⁾ CF
0.5	26.0	3/8	11	31	17	9.0	30	26.0	13.0	5.5	M 05×18	15.60×1.78	0.17	BFW3-G38/LK26	315
0.5	26.0	1/2	11	31	17	9.0	30	26.0	13.0	5.5	M 05×18	15.60×1.78	0.18	BFW3-G12/LK26	315
1.0	30.0	3/8	12	31	17	9.0	30	30.0	15.0	6.5	M 06×20	15.88×2.62	0.19	BFW3-G38/LK30	315
1.0	30.0	1/2	12	31	17	9.0	30	30.0	15.0	6.5	M 06×20	15.88×2.62	0.18	BFW3-G12/LK30	315
2.0	40.0	1/2	18	36	23	11.5	36	40.0	20.0	8.5	M 08×25	23.81×2.62	0.37	BFW3-G12/LK40	315
2.0	40.0	3/4	19	36	23	11.5	36	40.0	20.0	8.5	M 08×25	23.81×2.62	0.33	BFW3-G34/LK40	315
3.0	51.0	3/4	24	46	26	13.0	45	51.0	25.5	10.5	M 10×30	29.75×3.53	0.67	BFW3-G34/LK51	315
3.0	51.0	1	24	46	26	13.0	45	51.0	25.5	10.5	M 10×30	29.75×3.53	0.56	BFW3-G1/LK51	315
3B	56.0	3/4	24	46	26	13.0	45	56.0	28.0	10.5	M 10×30	29.75×3.53	0.61	BFW3-G34/LK56	315
3B	56.0	1	24	46	26	13.0	45	56.0	28.0	10.5	M 10×30	29.75×3.53	0.57	BFW3-G1/LK56	315
3.5	62.0	1 1/4	31	55	35	14.0	55	62.0	31.0	10.5	M 10×30	37.69×3.53	0.95	BFW3-G114/LK62	315
3.5	62.0	1	25	55	35	14.0	55	62.0	31.0	10.5	M 10×30	37.69×3.53	1.00	BFW3-G1/LK62	315
3.5	62.0	1 1/4	31	55	35	14.0	55	62.0	31.0	13.0	M 12×35	37.69×3.53	0.95	BFW3-G114/LK62/12	315
3.5	62.0	1	25	55	35	14.0	55	62.0	31.0	13.0	M 12×35	37.69×3.53	1.20	BFW3-G1/LK62/12	315
4.0	72.5	1 1/2	38	58	38	15.0	62	72.5	36.2	13.0	M 12×35	47.22×3.53	1.12	BFW3-G112/LK72.5	315
4.0	72.5	1 1/4	31	58	38	15.0	62	72.5	36.2	13.0	M 12×35	47.22×3.53	1.14	BFW3-G114/LK72.5	315

¹⁾ Pressure shown = Item deliverable

$$\frac{\text{PN (bar)}}{10} = \text{PN (MPa)}$$

*Please add the **suffixes** below according to the material/surface required.

Order code suffixes			
Material	Suffix surface and material	Example incl. metr. bolts and O-ring	Standard sealing material (no additional suffix needed)
Steel, zinc plated, Cr(VI)-free	CF	BFW3-G38/LK26CFM	NBR

Gear pump flanges

PWDS-G Gear pump flange 90° elbow 4 holes – aluminium

Hydraulic flange / Female BSPP thread

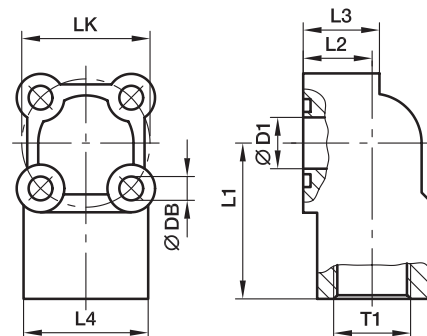
PWDS-G 90° Female BSPP thread

LK	T1	D1	L1	L2	L3	L4	DB	Bolts		O-ring	Weight (steel) kg/piece	Order code*	PN (bar) ¹⁾ A
								2 pieces (metr.)	2 pieces (metr.)				
30	G 3/8	11.5	39.0	18	20	33	6.5	M 06×30	M 06×40	15.88×2.62	0.14	PWDS-G38/LK30	180
30	G 1/2	11.5	39.0	18	20	33	6.5	M 06×30	M 06×40	15.88×2.62	0.14	PWDS-G12/LK30	180
35	G 3/8	14.0	42.5	18	20	34	6.5	M 06×30	M 06×40	18.72×2.62	0.16	PWDS-G38/LK35	180
35	G 1/2	14.0	42.5	18	20	34	6.5	M 06×30	M 06×40	18.72×2.62	0.15	PWDS-G12/LK35	180
40	G 1/2	18.0	47.5	24	28	41	6.5	M 06×40	M 06×50	22.22×2.62	0.25	PWDS-G12/LK40	180
40	G 3/4	18.0	47.5	24	28	41	6.5	M 06×40	M 06×50	22.22×2.62	0.24	PWDS-G34/LK40	180
55	G 3/4	24.5	54.0	29	31	49	8.5	M 08×45	M 08×60	29.75×3.53	0.45	PWDS-G34/LK55	180
55	G 1	24.5	54.0	29	31	49	8.5	M 08×45	M 08×60	29.75×3.53	0.43	PWDS-G1/LK55	180

¹⁾Pressure shown = Item deliverable

$$\frac{\text{PN (bar)}}{10} = \text{PN (MOPa)}$$

 *Please add the **suffixes** below according to the material/surface required.

Order code suffixes			
Material	Suffix surface and material	Example incl. metr. bolts and O-ring	Standard sealing material (no additional suffix needed)
Aluminium	A	PWDS-G38/LK30AM	NBR

PWDA Gear pump flange 90° elbow 3 holes – aluminium

Hydraulic flange / Female BSPP thread

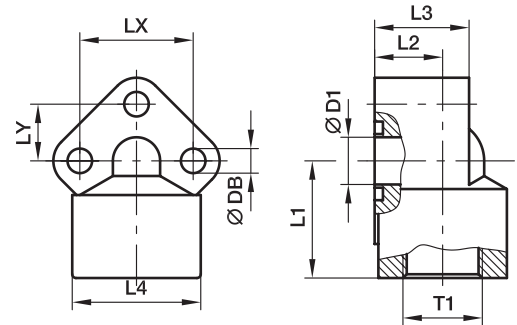

PWDA 90° Female BSPP thread

Pump size	LK	T1	D1	L1	L2	L3	L4	LX	LY	DB	Boles (metr.)	O-ring	Weight (steel) kg/piece	Order code*	PN (bar) ¹⁾ A
0.5	26	G 3/8	10.0	31	18.0	25	31	26	13.0	5.5	M 05×35	14.00×1.78	0.10	PWDA-05/38	180
0.5	26	G 1/2	10.0	31	18.0	25	31	26	13.0	5.5	M 05×35	14.00×1.78	0.10	PWDA-05/12	180
1.0	30	G 3/8	12.5	31	18.0	26	34	30	15.0	6.5	M 06×35	15.88×2.62	0.13	PWDA-1/38	180
1.0	30	G 1/2	12.5	31	18.0	26	34	30	15.0	6.5	M 06×35	15.88×2.62	0.14	PWDA-1/12	180
2.0	40	G 1/2	18.0	40	21.5	31	42	40	20.0	8.5	M 08×45	22.22×2.62	0.26	PWDA-2/12	180
2.0	40	G 3/4	18.0	40	21.5	31	42	40	20.0	8.5	M 08×45	22.22×2.62	0.26	PWDA-2/34	180
3.0*	51 -56	G 3/4	24.5	46	26.0	42	49	51 -56	25.5 -28	11.0	M 10×60	29.75×3.53	0.52	PWDA-3/34	180
3.0*	51 -56	G 1	24.5	46	26.0	42	49	51 -56	25.5 -28	11.0	M 10×60	29.75×3.53	0.50	PWDA-3/100	180

¹⁾Pressure shown = Item deliverable

*Oval drill hole

$\frac{PN \text{ (bar)}}{10} = PN \text{ (MPa)}$

*Please add the **suffixes** below according to the material/surface required.

Order code suffixes			
Material	Suffix surface and material	Example incl. metr. bolts and O-ring	Standard sealing material (no additional suffix needed)
Aluminium	A	PWDA-05/38AM	NBR

PSFC Square flange

ISO 6164

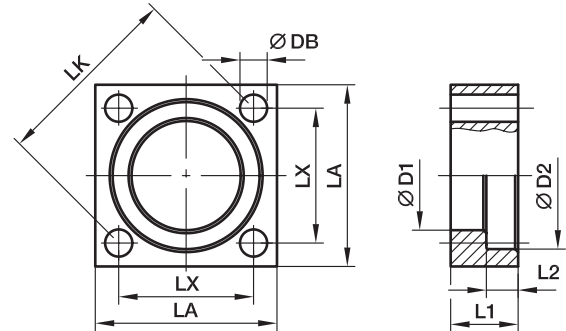

250 bar Series

Series ²⁾	Nom. flange size		LK	D1	D2	L1	L2	LA	LX	DB	Weight (steel) kg/piece	Order code*	PN (bar) ¹⁾ S
	SAE (in.)	ISO (DN)											
L	3/8	10	35	18.5	25.0	18	6.2	40	24.7	6.6	0.19	PSFC/L/10	250
L	1/2	13	42	24.3	31.0	20	6.2	45	29.7	9.0	0.20	PSFC/L/13	250
L	3/4	19	50	32.2	38.9	22	6.2	50	35.4	9.0	0.23	PSFC/L/19	250
L	1	25	62	38.5	45.3	25	7.5	65	43.8	11.0	0.52	PSFC/L/25	250
L	1 1/4	32	73	43.7	51.6	30	7.5	75	51.6	13.5	0.82	PSFC/L/32	250
L	1 1/2	38	85	50.8	61.1	36	7.5	90	60.1	17.5	1.40	PSFC/L/38	250
L	2	51	98	62.8	72.3	40	9.0	100	69.3	17.5	1.77	PSFC/L/51	250
L	2 1/2	56	118	76.6	88.0	45	9.0	120	83.4	22.0	2.75	PSFC/L/56	250
L	3	63	145	90.8	102.3	52	9.0	140	102.5	22.0	4.47	PSFC/L/63	250
L	4	80	160	114.5	132.0	60	21.0	160	113.5	25.0	6.00	PSFC/L/80	250

400 bar Series

S	3/8	10	35	18.5	26.4	18	7.2	40	24.7	6.6	0.17	PSFC/S/10	400
S	1/2	13	42	24.7	32.6	20	7.2	45	29.7	9.0	0.20	PSFC/S/13	400
S	3/4	19	50	32.5	42.1	22	8.2	50	35.4	9.0	0.23	PSFC/S/19	400
S	1	25	62	38.9	48.4	25	9.0	65	43.8	11.0	0.50	PSFC/S/25	400
S	1 1/4	32	73	44.6	54.8	30	9.8	75	51.6	13.5	0.78	PSFC/S/32	400
S	1 1/2	38	85	51.6	64.3	36	12.0	90	60.1	17.5	1.33	PSFC/S/38	400
S	2	51	98	67.6	80.2	40	12.0	100	69.3	17.5	1.59	PSFC/S/51	400
S	2 1/2	56	118	80.5	95.0	50	16.1	120	83.4	22.0	2.98	PSFC/S/56	400
S	3	63	145	90.5	111.0	52	16.1	150	102.5	26.0	5.70	PSFC/S/63	400
S	3 1/2	70	160	102.5	120.0	60	17.5	160	113.1	26.0	6.57	PSFC/S/70	400
S	4	80	175	114.5	136.0	70	21.0	180	123.7	33.0	9.70	PSFC/S/80	350

¹⁾ Pressure shown = Item deliverable

²⁾ L = light series; S = heavy series

$$\frac{PN \text{ (bar)}}{10} = PN \text{ (MPa)}$$

The pressures given here are the maximum allowable for the flange fittings. If the pipe or tube used has a lower pressure rating, then the welded assembly rating will be the lower one, assuming the weld is adequately strong.

*Please add the **suffixes** below according to the material/surface required.

Order code suffixes			
Material	Suffix surface and material	Example	Description
Steel, zinc plated, Cr(VI)-free	CF	PSFC/L/10CF	only flange clamp

PSFA-B Square flange adapter (butt weld)

Square flange / Butt weld end
(ISO 6164)

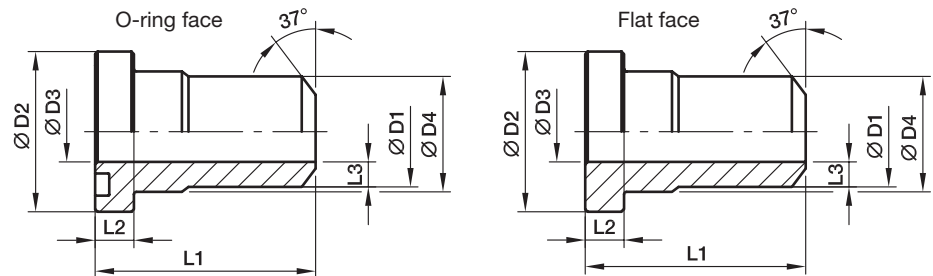

250 bar Series

Se-ries ²⁾	Nom. flange size		D1	D2	D3	D4	L1	L2	L3	O-ring	Weight (steel) kg/piece	O-ring face Order code*	Flat face Order code*	PN (bar) ¹⁾ S
	SAE (in.)	ISO (DN)												
L	3/8	10	17.5	24.5	10	18.0	40	6.8	3.75	17.13×2.62	0.09	PSFA10/L/17.5B	PSCFA10/L/17.5B	250
L	1/2	13	21.6	30.2	13	24.0	50	6.8	4.30	18.64×3.53	0.13	PSFA13/L/21.6B	PSCFA13/L/21.6B	250
L	3/4	19	27.2	38.1	19	31.5	60	6.8	4.10	24.99×3.53	0.22	PSFA19/L/27.2B	PSCFA19/L/27.2B	250
L	1	25	34.5	44.5	25	38.0	70	8.0	4.75	32.93×3.53	0.35	PSFA25/L/34.5B	PSCFA25/L/34.5B	250
L	1 1/4	32	43.0	50.8	31	43.0	80	8.0	6.00	37.89×3.53	0.50	PSFA32/L/43B	PSCFA32/L/43B	250
L	1 1/2	38	48.6	60.4	38	50.0	90	8.0	5.30	47.22×3.53	0.62	PSFA38/L/48.6B	PSCFA38/L/48.6B	250
L	2	51	61.0	71.4	50	62.0	100	9.6	5.50	56.74×3.53	0.88	PSFA51/L/61B	PSCFA51/L/61B	250
L	2 1/2	56	76.6	87.2	63	76.0	110	12.0	6.80	69.44×3.53	1.40	PSFA56/L/76.6B	PSCFA56/L/76.6B	250
L	3	63	89.0	101.6	70	90.0	120	15.0	9.50	85.32×3.53	2.57	PSFA63/L/89B	PSCFA63/L/89B	250
L	4	80	114.0	131.0	90	114.0	140	23.5	12.00	97.79×5.34	6.03	PSFA80/L/114B	PSCFA80/L/114B	250

400 bar Series

S	3/8	10	17.5	26.0	10	18.0	40	7.8	3.75	17.13×2.62	0.08	PSFA10/S/17.5B	PSCFA10/S/17.5B	400
S	1/2	13	21.6	31.8	13	24.0	50	7.8	4.30	18.64×3.53	0.14	PSFA13/S/21.6B	PSCFA13/S/21.6B	400
S	3/4	19	27.2	41.3	18	32.0	60	8.8	4.60	24.99×3.53	0.26	PSFA19/S/27.2B	PSCFA19/S/27.2B	400
S	1	25	34.5	47.6	22	38.0	70	9.5	6.25	32.93×3.53	0.45	PSFA25/S/34.5B	PSCFA25/S/34.5B	400
S	1 1/4	32	43.0	54.0	28	44.0	90	10.3	7.50	37.89×3.53	0.65	PSFA32/S/43B	PSCFA32/S/43B	400
S	1 1/2	38	48.6	63.5	32	51.0	90	12.6	8.30	47.22×3.53	0.99	PSFA38/S/48.6B	PSCFA38/S/48.6B	400
S	2	51	61.0	79.4	41	67.0	100	12.6	10.00	56.52×5.34	1.73	PSFA51/S/61B	PSCFA51/S/61B	400
S	2 1/2	56	76.6	94.2	50	90.0	110	16.5	13.30	69.22×5.34	2.70	PSFA56/S/76.6B	PSCFA56/S/76.6B	400
S	3	63	89.0	104.0	58	90.0	120	18.0	15.50	75.57×5.34	3.64	PSFA63/S/89B	PSCFA63/S/89B	400
S	3 1/2	70	102.0	119.0	63	102.0	130	20.0	19.50	85.09×5.34	5.55	PSFA70/S/102B	PSCFA70/S/102B	400
S	4	80	114.0	131.0	74	114.0	140	23.5	20.00	88.27×5.34	7.10	PSFA80/S/114B	PSCFA80/S/114B	350

¹⁾ Pressure shown = Item deliverable

²⁾ L = light series; S = heavy series

$$\frac{\text{PN (bar)}}{10} = \text{PN (MPa)}$$

The pressures given here are the maximum allowable for the flange fittings. If the pipe or tube used has a lower pressure rating, then the welded assembly rating will be the lower one, assuming the weld is adequately strong.

*Please add the **suffixes** below according to the material/surface required.

Order code suffixes			
Material	Suffix surface and material	Example	Description
Steel, blanc oil dipped	S	PSFA10/L/17.5BS	only flange adapter

PSFP Square flange plug

ISO 6164

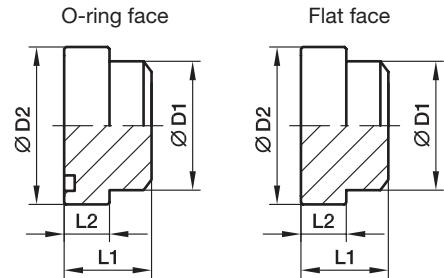

250 bar Series

Series ²⁾	Nom. flange size		D1	D2	L1	L2	O-ring	Weight (steel) kg/piece	O-ring face Order code*	Flat face Order code*	PN (bar) ¹⁾ S
	SAE (in.)	ISO (DN)									
L	3/8	10	18.0	24.5	18.0	6.8	17.13×2.62	0.07	PSFP10/L/18B	PSCFP10/L/18B	250
L	1/2	13	24.0	30.2	20.0	6.8	18.64×3.53	0.08	PSFP13/L/24B	PSCFP13/L/24B	250
L	3/4	19	31.5	38.1	22.0	6.8	24.99×3.53	0.17	PSFP19/L/31.5B	PSCFP19/L/31.5B	250
L	1	25	38.0	44.5	25.0	8.0	32.93×3.53	0.24	PSFP25/L/38B	PSCFP25/L/38B	250
L	1 1/4	32	43.0	50.8	30.0	8.0	37.89×3.53	0.38	PSFP32/L/43B	PSCFP32/L/43B	250
L	1 1/2	38	50.0	60.4	36.0	8.0	47.22×3.53	0.63	PSFP38/L/50B	PSCFP38/L/50B	250
L	2	51	62.0	71.4	40.0	9.6	56.74×3.53	1.03	PSFP51/L/62B	PSCFP51/L/62B	250
L	2 1/2	56	76.0	87.2	45.0	12.0	69.44×3.53	1.75	PSFP56/L/76B	PSCFP56/L/76B	250
L	3	63	90.0	101.6	52.0	15.0	85.32×3.53	2.81	PSFP63/L/90B	PSCFP63/L/90B	250
L	4	80	114.0	131.0	61.5	23.5	97.79×5.34	4.50	PSFP80/L/114B	PSCFP80/L/114B	250

400 bar Series

S	3/8	10	18.0	26.0	18.0	7.8	17.13×2.62	0.08	PSFP10/S/18B	PSCFP10/S/18B	400
S	1/2	13	24.0	31.8	20.0	7.8	18.64×3.53	0.10	PSFP13/S/24B	PSCFP13/S/24B	400
S	3/4	19	32.0	41.3	22.0	8.8	24.99×3.53	0.19	PSFP19/S/32B	PSCFP19/S/32B	400
S	1	25	38.0	47.6	25.0	9.5	32.93×3.53	0.28	PSFP25/S/38B	PSCFP25/S/38B	400
S	1 1/4	32	44.0	54.0	30.0	10.3	37.89×3.53	0.43	PSFP32/S/44B	PSCFP32/S/44B	400
S	1 1/2	38	51.0	63.5	36.0	12.6	47.22×3.53	0.70	PSFP38/S/51B	PSCFP38/S/51B	400
S	2	51	67.0	79.4	40.0	12.6	56.52×5.34	1.28	PSFP51/S/67B	PSCFP51/S/67B	400
S	2 1/2	56	80.0	94.2	45.0	16.5	69.22×5.34	2.21	PSFP56/S/80B	PSCFP56/S/80B	400
S	3	63	90.0	104.0	52.0	18.0	75.57×5.34	2.80	PSFP63/S/90B	PSCFP63/S/90B	400
S	3 1/2	70	102.0	119.0	60.0	20.0	85.09×5.34	4.29	PSFP70/S/102B	PSCFP70/S/102B	400
S	4	80	114.0	131.0	70.0	23.5	88.27×5.34	4.50	PSFP80/S/114B	PSCFP80/S/114B	350

¹⁾ Pressure shown = Item deliverable

²⁾ L = light series; S = heavy series

$$\frac{PN \text{ (bar)}}{10} = PN \text{ (MPa)}$$

The pressures given here are the maximum allowable for the flange fittings. If the pipe or tube used has a lower pressure rating, then the welded assembly rating will be the lower one, assuming the weld is adequately strong.

*Please add the **suffixes** below according to the material/surface required.

Order code suffixes			
Material	Suffix surface and material	Example	Description
Steel, blanc oil dipped	S	PSFP10/L/18BS	only flange plug

PSF-B Square flange (butt weld adapter coupling)

Square flange / Butt weld end
(ISO 6164)

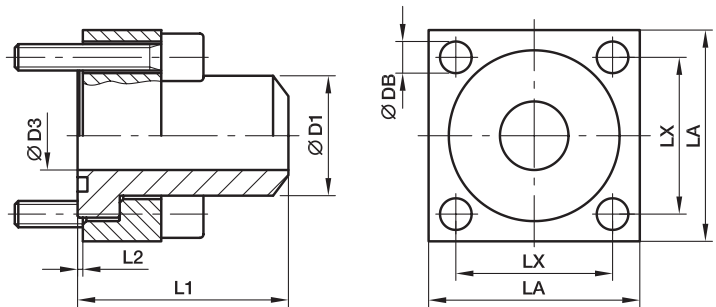

250 bar Series

Series ²⁾	Nom. flange size		D1	D3	L1	L2	LA	LX	DB	Bolts (metr.)	O-ring	Weight (steel) kg/piece	Order code*	PN (bar) ¹⁾ S
	SAE (in.)	ISO (DN)												
L	3/8	10	17.5	10	40	0.4	40	24.7	6.6	M 06×30	17.13×2.62	0.25	PSF10/L/17.5B	250
L	1/2	13	21.6	13	50	0.4	45	29.7	9.0	M 08×35	18.64×3.53	0.30	PSF13/L/21.6B	250
L	3/4	19	27.2	19	60	0.4	50	35.4	9.0	M 08×35	24.99×3.53	0.53	PSF19/L/27.2B	250
L	1	25	34.5	25	70	0.5	65	43.8	11.0	M 10×40	32.93×3.53	0.98	PSF25/L/34.5B	250
L	1 1/4	32	43.0	31	80	0.5	75	51.6	13.5	M 12×50	37.89×3.53	1.53	PSF32/L/43B	250
L	1 1/2	38	48.6	38	90	0.5	90	60.1	17.5	M 16×60	47.22×3.53	2.52	PSF38/L/48.6B	250
L	2	51	61.0	50	100	0.6	100	69.3	17.5	M 16×70	56.74×3.53	3.23	PSF51/L/61B	250
L	2 1/2	56	76.6	63	110	3.0	120	83.4	22.0	M 20×80	69.44×3.53	5.82	PSF56/L/76.6B	250
L	3	63	89.0	70	120	6.0	140	102.5	22.0	M 20×90	85.32×3.53	8.19	PSF63/L/89B	250
L	4	80	114.0	90	140	2.5	160	113.5	25.0	M 24×100	97.79×5.34	12.45	PSF80/L/114B	250

400 bar Series

S	3/8	10	17.5	10	40	0.6	40	24.7	6.6	M 06×30	17.13×2.62	0.26	PSF10/S/17.5B	400
S	1/2	13	21.6	13	50	0.6	45	29.7	9.0	M 08×35	18.64×3.53	0.31	PSF13/S/21.6B	400
S	3/4	19	27.2	18	60	0.6	50	35.4	9.0	M 08×35	24.99×3.53	0.55	PSF19/S/27.2B	400
S	1	25	34.5	22	70	0.5	65	43.8	11.0	M 10×40	32.93×3.53	1.02	PSF25/S/34.5B	400
S	1 1/4	32	43.0	28	90	0.5	75	51.6	13.5	M 12×50	37.89×3.53	1.70	PSF32/S/43B	400
S	1 1/2	38	48.6	32	90	0.6	90	60.1	17.5	M 16×60	47.22×3.53	2.76	PSF38/S/48.6B	400
S	2	51	61.0	41	100	0.6	100	69.3	17.5	M 16×70	56.52×5.34	3.81	PSF51/S/61B	400
S	2 1/2	56	76.6	50	110	0.4	120	83.4	22.0	M 20×80	69.22×5.34	6.75	PSF56/S/76.6B	400
S	3	63	89.0	58	120	1.9	150	102.5	26.0	M 24×90	75.57×5.34	11.00	PSF63/S/89B	400
S	3 1/2	70	102.0	63	130	2.5	160	113.1	26.0	M 24×100	85.09×5.34	13.60	PSF70/S/102B	400
S	4	80	114.0	74	140	2.5	180	123.7	33.0	M 30×120	88.27×5.34	19.97	PSF80/S/114B	350

¹⁾ Pressure shown = Item deliverable

²⁾ L = light series; S = heavy series

$$\frac{\text{PN (bar)}}{10} = \text{PN (MPa)}$$

The pressures given here are the maximum allowable for the flange fittings. If the pipe or tube used has a lower pressure rating, then the welded assembly rating will be the lower one, assuming the weld is adequately strong.

*Please add the **suffixes** below according to the material/surface required.

Order code suffixes			
Material	Suffix surface and material	Example incl. flange clamp, metr. bolts and O-ring	Standard sealing material (no additional suffix needed)
Steel, blanc oil dipped	S	PSF10/L/17.5BS	NBR

PDSF-B Square flange (butt weld connection)

Square flange / Butt weld tube end
(ISO 6164)

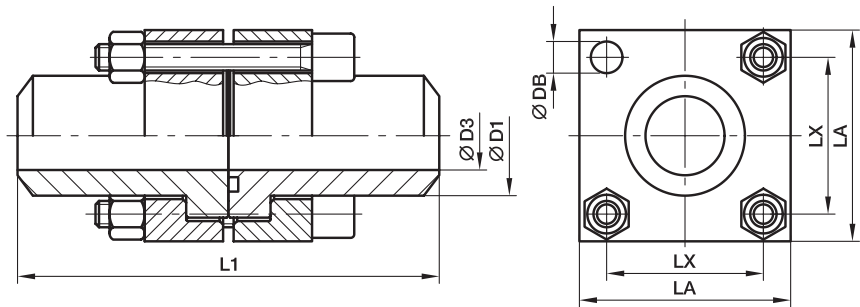

250 bar Series

Series ²⁾	Nom. flange size		D1	D3	L1	LA	LX	DB	Bolts (Metr.)	O-ring	Weight (steel) kg/piece	Order code*	PN (bar) ¹⁾ S
	SAE (in.)	ISO (DN)											
L	3/8	10	17.5	10	80	40	24.7	6.6	M 06x45	17.13x2.62	0.50	PDSF10/L/17.5B	250
L	1/2	13	21.6	13	100	45	29.7	9.0	M 08x50	18.64x3.53	0.60	PDSF13/L/21.6B	250
L	3/4	19	27.2	19	120	50	35.4	9.0	M 08x55	24.99x3.53	1.06	PDSF19/L/27.2B	250
L	1	25	34.5	25	140	65	43.8	11.0	M 10x65	32.93x3.53	1.96	PDSF25/L/34.5B	250
L	1 1/4	32	43.0	31	160	75	51.6	13.5	M 12x75	37.89x3.53	3.06	PDSF32/L/43B	250
L	1 1/2	38	48.6	38	180	90	60.1	17.5	M 16x90	47.22x3.53	5.04	PDSF38/L/48.6B	250
L	2	51	61.0	50	200	100	69.3	17.5	M 16x100	56.74x3.53	6.46	PDSF51/L/61B	250
L	2 1/2	56	76.6	63	220	120	83.4	22.0	M 20x120	69.44x3.53	11.62	PDSF56/L/76.6B	250
L	3	63	89.0	70	240	140	102.5	22.0	M 20x140	85.32x3.53	16.38	PDSF63/L/89B	250
L	4	80	114.0	90	280	160	113.5	25.0	M 24x150	97.79x5.34	24.90	PDSF80/L/114B	250

400 bar Series

S	3/8	10	17.5	10	80	40	24.7	6.6	M 06x45	17.13x2.62	0.52	PDSF10/S/17.5B	400
S	1/2	13	21.6	13	100	45	29.7	9.0	M 08x50	18.64x3.53	0.62	PDSF13/S/21.6B	400
S	3/4	19	27.2	18	120	50	35.4	9.0	M 08x55	24.99x3.53	1.10	PDSF19/S/27.2B	400
S	1	25	34.5	22	140	65	43.8	11.0	M 10x65	32.93x3.53	2.04	PDSF25/S/34.5B	400
S	1 1/4	32	43.0	28	180	75	51.6	13.5	M 12x75	37.89x3.53	3.40	PDSF32/S/43B	400
S	1 1/2	38	48.6	32	180	90	60.1	17.5	M 16x90	47.22x3.53	5.52	PDSF38/S/48.6B	400
S	2	51	61.0	41	200	100	69.3	17.5	M 16x100	56.52x5.34	7.62	PDSF51/S/61B	400
S	2 1/2	56	76.6	50	220	120	83.4	22.0	M 20x130	69.22x5.34	13.50	PDSF56/S/76.6B	400
S	3	63	89.0	58	240	150	102.5	26.0	M 24x140	75.57x5.34	22.00	PDSF63/S/89B	400
S	3 1/2	70	102.0	63	260	160	113.1	26.0	M 24x150	85.09x5.34	27.20	PDSF70/S/102B	400
S	4	80	114.0	74	280	180	123.7	33.0	M 30x180	88.27x5.34	39.94	PDSF80/S/114B	350

¹⁾ Pressure shown = Item deliverable

²⁾ L = light series; S = heavy series

$$\frac{\text{PN (bar)}}{10} = \text{PN (M Pa)}$$

The pressures given here are the maximum allowable for the flange fittings. If the pipe or tube used has a lower pressure rating, then the welded assembly rating will be the lower one, assuming the weld is adequately strong.











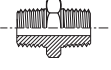
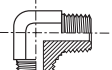
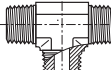
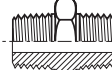

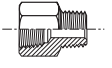
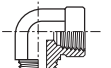
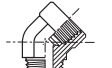

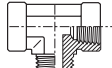
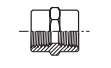

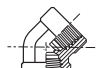
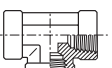
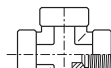
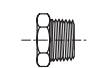

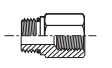
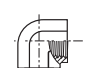

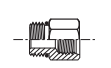
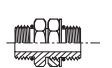
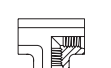

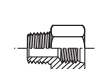
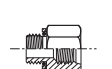
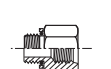
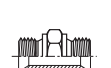

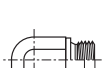
*Please add the **suffixes** below according to the material/surface required.

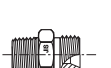
Order code suffixes			
Material	Suffix surface and material	Example Flange coupling incl. flange clamps, metr. bolts and O-ring	Standard sealing material (no additional suffix needed)
Steel, blanc oil dipped	S	PDSF10/L/17.5BS	NBR

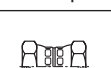

Adapters

Visual index

NPTF Adapters Male/male						
	FF / p.04	CR / p.05	RRS / p.05	FFFM / p.06		
NPTF Adapters Male/Female						
	PTRM / p.07	FGM / p.08	CDM / p.09	CD45 / p.010	MRO / p.011	MMS / p.012
NPTF Adapters Female/Female						
	GG / p.013	DD / p.014	DD45 / p.014	MMO / p.015	KMMOO / p.015	
NPTF Plug			UNF/NPTF Adapters			
	HP / p.016	HHP / p.016		F5OG / p.017	AOEG / p.018	AOE4G / p.018
UNF Adapters				UNF/ Plugs		
	F5OG5 / p.019	F5OHAO / p.020	G5G5JG5 / p.020		P5ONM / p.021	HP5ON / p.022
BSPT-BSPP metric-UNF Conversion adapters						
	F3HG5 / p.023	F4OHG5 / p.024	F8OHG5 / p.025			
Male/Male adapters BSPP 60° cone, BSPT, NPT						
	HMK4 / p.026	WMK4WL4NM / p.027	EMK4 / p.028	JMK4 / p.028	F3MK4 / p.038	FMK4 / p.040
Male/Female swivel adapters BSPP 60° cone						
	F6MK4 / p.030	C6MK4 / p.031	R6MK4 / p.032	S6MK4 / p.033		
Female/Female swivel adapters BSPP 60° cone						
	H6MK4 / p.034	E6MK4 / p.035	J6MK4 / p.036			

Visual index

BSPP 60° cone Expander/Adapter cap				
	G4MK4 / p.O37	FNMK4 / p.O39	PNMK4 / p.O29	
BSPP Adapters Female/Female				
	GG44M / p.O41 MMO444M / p.O42			
Reducing bushes BSPP/BSPT		BSPT male union and plug		
	PTR34M / p.O43		FF33M / p.O44	HP3M p.O45
Female swivel NPSM / male NPTF				
	0107 / p.O46	2107 / p.O47	3107 / p.O48	
Female swivel NPSM / female NPTF				
	0207 / p.O49	2207 / p.O50		
Female swivel NPSM / male UNF				
	0507 / p.O51	2507 / p.O52	3507 / p.O53	
JIS Adapters Male to BSPT				JIS Unions
	F3T4 / p.O54	C3T4 / p.O55	V3T4 / p.O55	
	HP4 / p.O56	HP46 / p.O56		
JIS Adapters Female cone to BSPT				
	F3P4 / p.O57	C3P4 / p.O57	V3P4 / p.O58	F63P4 / p.O58
				G63P4 / p.O59
				G3P4 / p.O59
Seals/ Retaining ring				
	Adapter Components p.O60			



Adapters

FF Male nipple

Male NPTF* thread (SAE J476) / Male NPTF* thread (SAE J476)

SAE 140137

*Stainless Steel = NPT to prevent galling

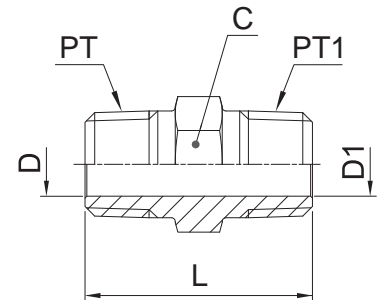

Thread NPT/NPTF PT	Thread NPT/NPTF PT1	C mm	D mm	D1 mm	L mm	Weight (steel) g/1 piece	Adapter Steel	Adapter Stainless Steel	PN (bar)	
									S	SS
1/8-27	1/8-27	11.0	4.8	4.8	27	11	1/8 FF-S	1/8FFMSS	420	420
1/4-18	1/8-27	16.0	7.1	4.8	32	31	1/4 X 1/8 FF-S	1/4X1/8FFMSS	420	420
1/4-18	1/4-18	16.0	7.1	7.1	37	28	1/4 FF-S	1/4FFMSS	420	420
3/8-18	1/8-27	19.0	10.3	4.8	32	45	3/8 X 1/8 FF-S	3/8X1/8FFMSS	420	420
3/8-18	1/4-18	19.0	10.3	7.0	37	51	3/8 X 1/4 FF-S	3/8X1/4FFMSS	420	420
3/8-18	3/8-18	19.0	10.3	10.3	37	40	3/8 FF-S	3/8FFMSS	420	420
1/2-14	1/8-27	22.2	13.5	4.8	39	58	1/2 X 1/8 FF-S	1/2X1/8FFMSS	420	420
1/2-14	1/4-18	22.2	13.5	7.1	43	88	1/2 X 1/4 FF-S	1/2X1/4FFMSS	420	420
1/2-14	3/8-18	22.2	13.5	10.3	43	71	1/2 X 3/8 FF-S	1/2X3/8FFMSS	420	420
1/2-14	1/2-14	22.2	13.5	13.5	48	71	1/2FFMS	1/2FFMSS	420	420
3/4-14	1/4-18	28.6	18.3	7.1	45	104	3/4 X 1/4 FF-S	3/4X1/4FFMSS	380	380
3/4-14	3/8-18	28.6	18.3	10.3	45	134	3/4 X 3/8 FF-S	3/4X3/8FFMSS	380	380
3/4-14	1/2-14	28.6	18.3	13.5	50	161	3/4 X 1/2 FF-S	3/4X1/2FFMSS	380	380
3/4-14	3/4-14	28.6	18.3	18.3	50	104	3/4 FF-S	3/4FFMSS	380	380
1-11.5	1-11.5	35.0	23.8	23.8	59	179	1 FF-S	1FFMSS	380	380
1-11.5	1/4-18	35.0	23.8	7.1	50	188	1 X 1/4 FF-S	1X1/4FFMSS	380	380
1-11.5	3/4-14	35.0	23.8	18.3	53	195	1 X 3/4 FF-S	1X3/4FFMSS	380	380
1 1/4-11.5	1-11.5	44.5	31.8	23.8	62	256	1 1/4 X 1 FF-S	11/4X1FFMSS	350	350
1 1/4-11.5	1 1/4-11.5	44.5	31.8	31.8	63	256	1 1/4 FF-S	11/4FFMSS	350	350
1 1/2-11.5	1-11.5	50.8	38.1	23.8	65	341	1 1/2 X 1 FF-S	11/2X1FFMX	210	210
1 1/2-11.5	1 1/2-11.5	50.8	38.1	38.1	66	364	1 1/2 FF-S	11/2FFMSS	210	210
2-11.5	2-11.5	63.5	49.2	49.2	72	848	2 FF-S	2FFMSS	170	170

Order codes shown are part of our current manufacturing programme.

Imperial and metric parts may vary in hexagon dimensions.

$$\frac{\text{PN (bar)}}{10} = \text{PN (MPa)}$$

Do not create drawings from these dimensions, they are subject to change and ISO manufacturing allowances.

CR Male thread elbow

Male NPTF* thread (SAE J476) / Male NPTF* thread (SAE J476)

SAE 140237

*Stainless Steel = NPT to prevent galling

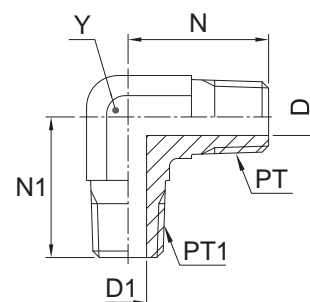

Thread NPT/NPTF PT	Thread NPT/NPTF PT1	D mm	D1 mm	N mm	N1 mm	Y mm	Weight (steel) g/1 piece	Adapter Steel	Adapter Stainless Steel	PN (bar)	
										S	SS
1/8-27	1/8-27	4.8	4.8	20	20	11.0	27	1/8 CR-S	1/8 CR-SS	420	420
1/4-18	1/4-18	7.1	7.1	28	28	14.0	54	1/4 CR-S	1/4 CR-SS	420	420
3/8-18	3/8-18	10.3	10.3	31	31	19.0	181	3/8 CR-S	3/8 CR-SS	420	420
3/8-18	1/4-18	10.3	7.1	31	31	19.0	66	3/8 X 1/4 CR-S	3/8 X 1/4 CR-SS	420	420
1/2-14	1/2-14	13.5	13.5	37	37	22.0	172	1/2 CR-S	1/2 CR-SS	420	420
1/2-14	3/8-18	13.5	10.3	37	33	22.0	103	1/2 X 3/8 CR-S	1/2 X 3/8 CR-SS	420	420
3/4-14	3/4-14	18.3	18.3	40	40	27.0	263	3/4 CR-S	3/4 CR-SS	280	280
3/4-14	1/2-14	18.3	13.5	40	37	27.0	164	3/4 X 1/2 CR-S	3/4 X 1/2 CR-SS	280	280
1-11.5	1-11.5	23.8	23.8	50	50	33.3	462	1 CR-S	1 CR-SS	210	210
1 1/4-11.5	1 1/4-11.5	31.8	31.8	56	56	47.6	782	1 1/4 CR-S	1 1/4 CR-SS	170	170
1 1/2-11.5	1 1/2-11.5	38.1	38.1	59	59	47.6	782	1 1/2 CR-S	1 1/2 CR-SS	170	170

Do not create drawings from these dimensions, they are subject to change and ISO manufacturing allowances.

RRS Male thread tee

Male NPTF* thread (SAE J476)

SAE 140437

*Stainless Steel = NPT to prevent galling

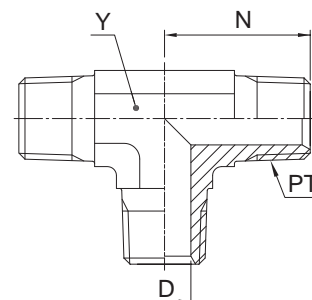

Thread NPT/NPTF PT	D mm	N mm	Y mm	Weight (steel) g/1 piece	Adapter Steel	Adapter Stainless Steel	PN (bar)	
							S	SS
1/8-27	4.8	20	11	33	1/8 RRS-S	1/8 RRS-SS	420	420
1/4-18	7.1	28	14	56	1/4 RRS-S	1/4 RRS-SS	420	420
3/8-18	10.3	31	19	92	3/8 RRS-S	3/8 RRS-SS	420	420
1/2-14	13.5	37	22	96	1/2 RRS-S	1/2 RRS-SS	420	420
3/4-14	18.3	40	27	235	3/4 RRS-S	3/4 RRS-SS	280	280

Order codes shown are part of our current manufacturing programme.

Imperial and metric parts may vary in hexagon dimensions.

$$\frac{\text{PN (bar)}}{10} = \text{PN (MPa)}$$

Do not create drawings from these dimensions, they are subject to change and ISO manufacturing allowances.

Adapters

FFFM Extended male nipple

Male NPTF* thread (SAE J476) / Male NPTF* thread (SAE J476)

*Stainless Steel = NPT to prevent galling

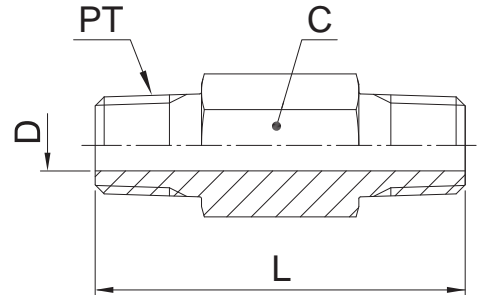

Thread NPT/NPTF PT	C mm	D mm	L mm	Weight (steel) g/1 piece	Adapter Steel	Adapter Stainless Steel	PN (bar)	
							S	SS
1/8-27	11.0	4.8	38	23	1/8 X 1.5 FFF-S	1/8X1.5FFFMS	420	420
1/8-27	11.0	4.8	51	33	1/8 X 2.0 FFF-S	1/8X2.0FFFMS	420	420
1/8-27	11.0	4.8	64	41	1/8 X 2.5 FFF-S	1/8X2.5FFFMS	420	420
1/8-27	11.0	4.8	76	50	1/8 X 3.0 FFF-S	1/8X3.0FFFMS	420	420
1/4-18	16.0	7.1	38	35	1/4 X 1.5 FFF-S	1/4X1.5FFFMS	420	420
1/4-18	16.0	7.1	51	51	1/4 X 2.0 FFF-S	1/4X2.0FFFMS	420	420
1/4-18	16.0	7.1	64	72	1/4 X 2.5 FFF-S	1/4X2.5FFFMS	420	420
1/4-18	16.0	7.1	76	93	1/4 X 3.0 FFF-S	1/4X3.0FFFMS	420	420
1/4-18	16.0	7.1	102	110	1/4 X 4.0 FFF-S	1/4X4.0FFFMS	420	420
1/2-14	22.2	13.5	51	91	1/2 X 2.0 FFF-S	1/2X2.0FFFMS	420	420
1/2-14	22.2	13.5	76	151	1/2 X 3.0 FFF-S	1/2X3.0FFFMS	420	420

Order codes shown are part of our current manufacturing programme.

Imperial and metric parts may vary in hexagon dimensions.

$$\frac{\text{PN (bar)}}{10} = \text{PN (MPa)}$$

Do not create drawings from these dimensions, they are subject to change and ISO manufacturing allowances.

PTRM Thread reducer

Male NPTF* thread (SAE J476) / Female NPTF* thread (SAE J476)

SAE 140140

*Stainless Steel = NPT to prevent galling

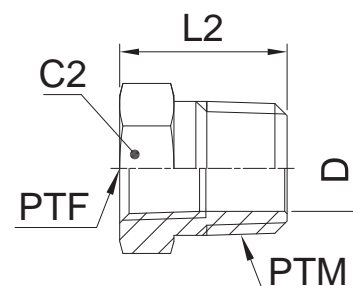

Thread NPT/NPTF PTM	Thread NPT/NPTF PTF	C2 mm	D mm	L2 mm	Weight (steel) g/1 piece	Adapter Steel	Adapter Stainless Steel	PN (bar)	
								S	SS
1/4-18	1/8-27	16.0	8.3	22	24	1/4 X 1/8 PTR-S	1/4X1/8PTRMSS	420	420
3/8-18	1/8-27	19.0	8.3	22	25	3/8 X 1/8 PTR-S	3/8X1/8PTRMSS	420	420
3/8-18	1/4-18	19.0	10.7	22	25	3/8 X 1/4 PTR-S	3/8X1/4PTRMSS	420	420
1/2-14	1/8-27	22.2	8.3	28	58	1/2 X 1/8 PTR-S	1/2X1/8PTRMSS	420	350
1/2-14	1/4-18	22.2	10.7	28	53	1/2 X 1/4 PTR-S	1/2X1/4PTRMSS	420	350
1/2-14	3/8-18	22.2	13.5	28	40	1/2 X 3/8 PTR-S	1/2X3/8PTRMSS	420	350
3/4-14	1/8-27	28.6	18.3	30	82	3/4 X 1/8 PTR-S	3/4X1/8PTRMSS	280	280
3/4-14	1/4-18	28.6	10.7	30	94	3/4 X 1/4 PTR-S	3/4X1/4PTRMSS	280	280
3/4-14	3/8-18	28.6	14.2	30	101	3/4 X 3/8 PTR-S	3/4X3/8PTRMSS	380	280
3/4-14	1/2-14	28.6	17.5	30	110	3/4 X 1/2 PTR-S	3/4X1/2PTRMSS	350	280
1-11.5	1/8-27	35.0	23.8	35	132	1 X 1/8 PTR-S	1X1/8PTRMSS	210	210
1-11.5	1/4-18	35.0	23.8	35	132	1 X 1/4 PTR-S	1X1/4PTRMSS	210	210
1-11.5	3/8-18	35.0	14.2	35	163	1 X 3/8 PTR-S	1X3/8PTRMSS	210	210
1-11.5	1/2-14	35.0	17.5	35	139	1 X 1/2 PTR-S	1X1/2PTRMSS	210	210
1-11.5	3/4-14	35.0	22.8	35	116	1 X 3/4 PTR-S	1X3/4PTRMSS	280	210
1 1/4-11.5	1/2-14	44.5	17.5	37	220	1 1/4 X 1/2 PTR-S	11/4X1/2PTRMSS	170	170
1 1/4-11.5	3/4-14	44.5	22.8	37	236	1 1/4 X 3/4 PTR-S	11/4X3/4PTRMSS	170	170
1 1/4-11.5	1-11.5	46.0	28.7	37	250	1 1/4X1PTRMS	11/4X1PTRMSS	210	175
1 1/2-11.5	3/4-14	50.8	22.8	40	306	1 1/2 X 3/4 PTR-S	11/2X3/4PTRMSS	140	140
1 1/2-11.5	1-11.5	50.0	29.0	40	360	1 1/2X1PTRMS	11/2X1PTRMSS	210	140
1 1/2-11.5	1 1/4-11.5	50.8	38.1	40	282	1 1/2X1 1/4 PTR-S	11/2X11/4PTRMSS	170	140
2-11.5	1/2-14	63.5	17.5	45	561	2 X 1/2 PTR-S	2X1/2PTRMSS	140	140
2-11.5	1-11.5	63.5	49.2	45	550	2 X 1 PTR-S	2X1PTRMSS	140	140
2-11.5	1 1/4-11.5	63.5	37.4	45	548	2 X 1 1/4 PTR-S	2X11/4PTRMSS	140	140

Order codes shown are part of our current manufacturing programme.

Imperial and metric parts may vary in hexagon dimensions.

$$\frac{\text{PN (bar)}}{10} = \text{PN (MPa)}$$

Do not create drawings from these dimensions, they are subject to change and ISO manufacturing allowances.

Adapters

FGM Thread expander / Adapter

Male NPTF* thread (SAE J476) / Female NPTF* thread (SAE J476)

SAE 140139

*Stainless Steel = NPT to prevent galling

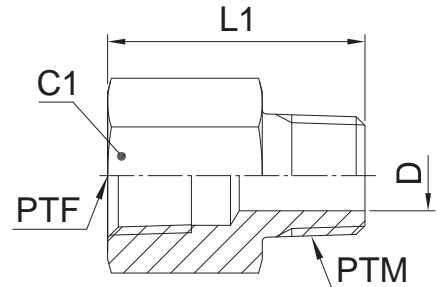

Thread NPT/NPTF PTF	Thread NPT/NPTF PTM	C1 mm	D mm	L1 mm	Weight (steel) g/1 piece	Adapter Steel	Adapter Stainless Steel	PN (bar)	
								S	SS
1/8-27	1/8-27	16.0	4.8	26	30	1/8 FG-S	1/8FGMSS	420	420
1/4-18	1/8-27	19.0	4.8	31	57	1/4 X 1/8 FG-S	1/4X1/8FGMSS	420	420
1/4-18	1/4-18	19.0	7.1	35	44	1/4 FG-S	1/4FGMSS	420	420
3/8-18	1/8-27	22.2	4.8	32	50	3/8 X 1/8 FG-S	3/8X1/8FGMSS	420	420
3/8-18	1/4-18	22.2	7.1	37	108	3/8 X 1/4 FG-S	3/8X1/4FGMSS	420	420
3/8-18	3/8-18	22.2	10.3	37	55	3/8 FG-S	3/8FGMSS	420	420
1/2-14	1/8-27	28.6	4.8	38	98	1/2 X 1/8 FG-S	1/2X1/8FGMSS	350	350
1/2-14	1/4-18	28.6	7.1	43	104	1/2 X 1/4 FG-S	1/2X1/4FGMSS	350	350
1/2-14	3/8-18	28.6	10.3	43	108	1/2 X 3/8 FG-S	1/2X3/8FGMSS	350	350
1/2-14	1/2-14	28.6	13.5	48	108	1/2 FG-S	1/2FGMSS	350	350
3/4-14	3/4-14	35.0	18.3	49	178	3/4 FG-S	3/4FGMSS	280	280
3/4-14	1/4-18	35.0	7.1	45	129	3/4 X 1/4 FG-S	3/4X1/4FGMSS	280	280
3/4-14	1/2-14	35.0	13.5	49	129	3/4 X 1/2FG-S	3/4X1/2FGMSS	280	280
1-11.5	1-11.5	41.3	23.8	60	160	1 FG-S	1FGMSS	210	210
1-11.5	1/2-14	41.3	13.5	56	180	1 X 1/2FG-S	1X1/2FGMSS	210	210
1-11.5	3/4-14	41.3	18.3	55	98	1 X 3/4FG-S	1X3/4FGMSS	210	210
1 1/4-11.5	1-11.5	50.8	23.8	63	296	1 1/4 X 1FG-S	11/4X1FGMSS	170	170

Order codes shown are part of our current manufacturing programme.

Imperial and metric parts may vary in hexagon dimensions.

$$\frac{PN \text{ (bar)}}{10} = PN \text{ (MPa)}$$

Do not create drawings from these dimensions, they are subject to change and ISO manufacturing allowances.

CDM Male female thread elbow

Male NPTF* thread (SAE J476) / Female NPTF* thread (SAE J476)

SAE 140239

*Stainless Steel = NPT to prevent galling

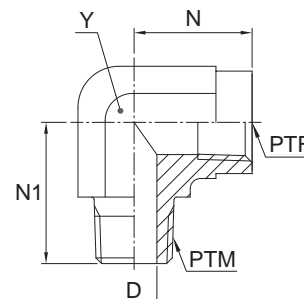

Thread NPT/NPTF PTM	Thread NPT/NPTF PTF	D mm	N mm	N1 mm	Y mm	Weight (steel) g/1 piece	Adapter Steel	Adapter Stainless Steel	PN (bar)	
									S	SS
1/8-27	1/8-27	4.8	20	17	14.0	30	1/8 CD-S	1/8 CD-SS	350	350
1/4-18	1/4-18	7.0	28	22	19.0	77	1/4 CDMS	1/4 CD-SS	350	350
1/4-18	1/8-27	7.1	28	17	14.0	33	1/4 X 1/8 CD-S	1/4 X 1/8 CD-SS	350	350
3/8-18	3/8-18	10.0	31	26	22.0	96	3/8 CDMS	3/8 CD-SS	310	310
3/8-18	1/4-18	10.3	31	22	19.0	79	3/8 X 1/4 CD-S	3/8 X 1/4 CD-SS	350	350
3/8-18	1/2-14	10.3	33	31	27.0	260	3/8 X 1/2 CD-S	3/8 X 1/2 CD-SS	210	210
1/2-14	1/2-14	13.5	37	31	27.0	174	1/2 CD-S	1/2 CD-SS	210	210
1/2-14	3/8-18	13.5	38	32	22.0	96	1/2 X 3/8 CD-S	1/2 X 3/8 CD-SS	310	310
1/2-14	3/4-14	13.5	40	35	33.3	319	1/2 X 3/4 CD-S	1/2 X 3/4 CD-SS	210	210
3/4-14	3/4-14	18.3	40	35	33.3	285	3/4 CD-S	3/4 CD-SS	210	210
3/4-14	1/2-14	18.3	40	31	27.0	164	3/4 X 1/2 CD-S	3/4 X 1/2 CD-SS	210	210
1-11.5	1-11.5	23.8	50	41	47.6	515	1 CD-S	1 CD-SS	125	120
1 1/4-11.5	1 1/4-11.5	31.8	61	43	47.6	978	1 1/4 CD-S	1 1/4 CD-SS	100	100
1 1/2-11.5	1 1/2-11.5	38.1	67	53	63.5	1679	1 1/2 CD-S	1 1/2 CD-SS	100	100

Order codes shown are part of our current manufacturing programme.

Imperial and metric parts may vary in hexagon dimensions.

$\frac{\text{PN (bar)}}{10} = \text{PN (MPa)}$

Do not create drawings from these dimensions, they are subject to change and ISO manufacturing allowances.

Adapters

CD45 Male female thread 45° elbow

Male NPTF* thread (SAE J476) / Female NPTF* thread (SAE J476)

SAE 140339

*Stainless Steel = NPT to prevent galling

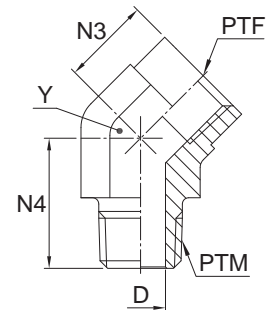

Thread NPT/NPTF PTM	Thread NPT/NPTF PTF	D mm	N3 mm	N4 mm	Y mm	Weight (steel) g/1 piece	Adapter Steel	Adapter Stainless Steel	PN (bar)	
									S	SS
1/8-27	1/8-27	4.8	12	18	14.0	24	1/8 CD45-S	1/8 CD45-SS	350	350
1/4-18	1/4-18	7.1	16	27	19.0	57	1/4 CD45-S	1/4 CD45-SS	350	350
3/8-18	3/8-18	10.3	18	27	22.0	79	3/8 CD45-S	3/8 CD45-SS	310	310
1/2-14	1/2-14	13.5	23	34	27.0	141	1/2 CD45-S	1/2 CD45-SS	210	210
3/4-14	3/4-14	18.3	25	35	33.3	196	3/4 CD45-S	3/4 CD45-SS	210	210
1-11.5	1-11.5	23.8	29	44	41.0	380	1 CD45-S	1 CD45-SS	125	120
1 1/4-11.5	1 1/4-11.5	31.8	41	46	47.6	719	1 1/4 CD45-S	1 1/4 CD45-SS	100	100

Order codes shown are part of our current manufacturing programme.

Imperial and metric parts may vary in hexagon dimensions.

$$\frac{\text{PN (bar)}}{10} = \text{PN (MPa)}$$

Do not create drawings from these dimensions, they are subject to change and ISO manufacturing allowances.

MRO Male female thread tee

Male NPTF* thread (SAE J476) / Female NPTF* thread (SAE J476)

SAE 140424

*Stainless Steel = NPT to prevent galling

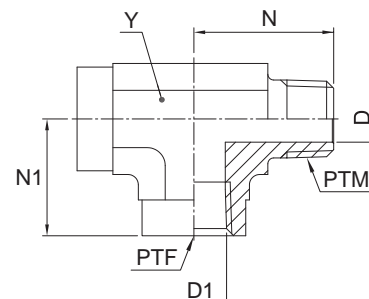

Thread NPT/NPTF PTM	Thread NPT/NPTF PTF	D mm	D1 mm	N mm	N1 mm	Y mm	Weight (steel) g/1 piece	Adapter Steel	Adapter Stainless Steel	PN (bar)	
										S	SS
1/8-27	1/8-27	4.8	8.3	20	17	14.0	59	1/8 MRO-S	1/8 MRO-SS	350	350
1/4-18	1/4-18	7.1	10.7	28	22	19.0	115	1/4 MRO-S	1/4 MRO-SS	350	350
3/8-18	3/8-18	10.3	14.2	31	26	22.0	122	3/8 MRO-S	3/8 MRO-SS	310	310
1/2-14	1/2-14	13.5	17.5	37	31	27.0	285	1/2 MRO-S	1/2 MRO-SS	210	210
3/4-14	3/4-14	18.3	22.8	40	35	33.3	497	3/4 MRO-S	3/4 MRO-SS	210	210
1-11.5	1-11.5	23.8	28.6	50	41	41.0	987	1 MRO-S	1 MRO-SS	125	120

Order codes shown are part of our current manufacturing programme.

Imperial and metric parts may vary in hexagon dimensions.

$$\frac{\text{PN (bar)}}{10} = \text{PN (MPa)}$$

Do not create drawings from these dimensions, they are subject to change and ISO manufacturing allowances.

Adapters

MMS Male female thread tee

Male NPTF* thread (SAE J476) / Female NPTF* thread (SAE J476)
SAE 140425

*Stainless Steel = NPT to prevent galling

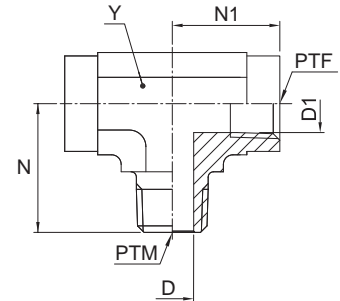

Thread NPT/NPTF PTM	Thread NPT/NPTF PTF	D mm	D1 mm	N mm	N1 mm	Y mm	Weight (steel) g/1 piece	Adapter Steel	Adapter Stainless Steel	PN (bar)	
										S	SS
1/8-27	1/8-27	4.8	8.3	20	17	14.0	45	1/8 MMS-S	1/8 MMS-SS	350	350
1/4-18	1/4-18	7.1	10.7	28	22	19.0	118	1/4 MMS-S	1/4 MMS-SS	350	350
3/8-18	3/8-18	10.3	14.2	31	26	22.0	126	3/8 MMS-S	3/8 MMS-SS	310	310
1/2-14	1/2-14	13.5	17.5	37	31	27.0	272	1/2 MMS-S	1/2 MMS-SS	210	210
3/4-14	3/4-14	18.3	22.8	40	35	33.3	408	3/4 MMS-S	3/4 MMS-SS	210	210
1-11.5	1-11.5	23.8	28.6	50	41	41.0	606	1 MMS-S	1 MMS-SS	125	120

Order codes shown are part of our current manufacturing programme.

Imperial and metric parts may vary in hexagon dimensions.

$$\frac{PN \text{ (bar)}}{10} = PN \text{ (MPa)}$$

Do not create drawings from these dimensions, they are subject to change and ISO manufacturing allowances.

GG Female thread coupling

Female NPTF* thread (SAE J476) / Female NPTF* thread (SAE J476)

SAE 140138

*Stainless Steel = NPT to prevent galling

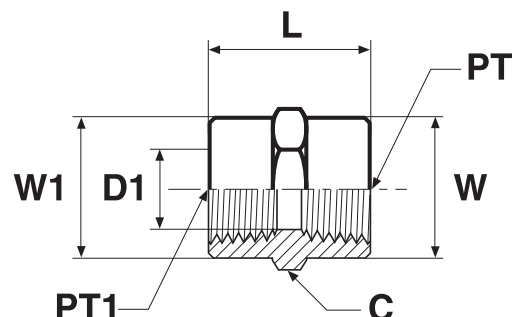

Thread NPT/NPTF PT	Thread NPT/NPTF PT1	C mm	D1 mm	L mm	W mm	W1 mm	Weight (steel) g/1 piece	Adapter Steel	Adapter Stainless Steel	PN (bar)	
										S	SS
1/8-27	1/8-27	16.0	8.3	19	16	16	19	1/8 GG-S	1/8 GG-SS	420	420
1/4-18	1/8-27	19.0	8.3	24	19	16	35	1/4 X 1/8 GG-S	1/4 X 1/8 GG-SS	420	420
1/4-18	1/4-18	19.0	10.7	29	19	19	45	1/4 GG-S	1/4 GG-SS	420	420
3/8-18	1/8-27	22.2	8.3	26	22	16	56	3/8 X 1/8 GG-S	3/8 X 1/8 GG-SS	420	420
3/8-18	1/4-18	22.2	10.7	29	22	19	56	3/8 X 1/4 GG-S	3/8 X 1/4 GG-SS	420	420
3/8-18	3/8-18	22.2	14.2	29	22	22	62	3/8 GG-S	3/8 GG-SS	420	420
1/2-14	1/4-18	28.6	10.7	35	29	19	117	1/2 X 1/4 GG-S	1/2 X 1/4 GG-SS	350	350
1/2-14	3/8-18	28.6	14.2	38	29	22	100	1/2 X 3/8 GG-S	1/2 X 3/8 GG-SS	350	350
1/2-14	1/2-14	28.6	17.5	38	29	29	112	1/2 GG-S	1/2 GG-SS	350	350
3/4-14	1/4-18	35.0	10.7	39	35	19	150	3/4 X 1/4 GG-S	3/4 X 1/4 GG-SS	280	280
3/4-14	1/2-14	35.0	17.5	48	35	29	134	3/4 X 1/2 GG-S	3/4 X 1/2 GG-SS	280	280
3/4-14	3/4-14	35.0	22.8	39	35	35	156	3/4 GG-S	3/4 GG-SS	280	280
1-11.5	1-11.5	41.3	28.6	48	41	41	289	1 GG-S	1 GG-SS	210	210
1-11.5	1/2-14	41.3	17.5	45	41	29	235	1 X 1/2 GG-S	1 X 1/2 GG-SS	210	210
1-11.5	3/4-14	41.3	22.8	45	41	35	239	1 X 3/4 GG-S	1 X 3/4 GG-SS	210	210
1 1/4-11.5	1 1/4-11.5	50.8	37.4	49	51	51	340	1 1/4 GG-S	1 1/4 GG-SS	170	170
1 1/4-11.5	1-11.5	50.8	28.6	49	51	41	182	1 1/4 X 1 GG-S	1 1/4 X 1 GG-SS	170	170
1 1/2-11.5	1 1/2-11.5	60.3	43.4	49	60	60	706	1 1/2 GG-S	1 1/2 GG-SS	140	140
1 1/2-11.5	1 1/4-11.5	60.3	37.4	49	60	60	531	1 1/2 X 1 1/4 GG-S	1 1/2 X 1 1/4 GG-SS	140	140
2-11.5	2-11.5	73.0	55.5	50	73	73	814	2 GG-S	2 GG-SS	140	140

Order codes shown are part of our current manufacturing programme.

Imperial and metric parts may vary in hexagon dimensions.

$\frac{\text{PN (bar)}}{10} = \text{PN (MPa)}$

Do not create drawings from these dimensions, they are subject to change and ISO manufacturing allowances.

Adapters

DD Female thread elbow

Female NPTF* thread (SAE J476)
SAE 140238

*Stainless Steel = NPT to prevent galling

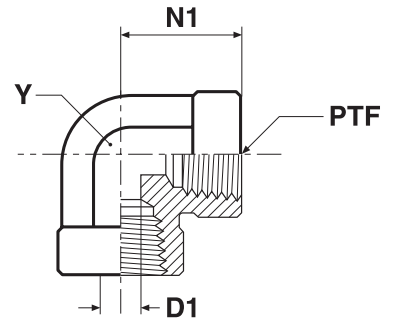

Thread NPT/NPTF PTF	D1 mm	N1 mm	Y mm	Weight (steel) g/1 piece	Adapter Steel	Adapter Stainless Steel	PN (bar)	
							S	SS
1/8-27	8.3	17	14.0	28	1/8 DD-S	1/8 DD-SS	350	350
1/4-18	10.7	22	19.0	72	1/4 DD-S	1/4 DD-SS	350	350
3/8-18	14.2	26	22.0	96	3/8 DD-S	3/8 DD-SS	310	310
1/2-14	17.5	31	27.0	159	1/2 DD-S	1/2 DD-SS	210	210
3/4-14	22.8	35	33.3	263	3/4 DD-S	3/4 DD-SS	210	210
1-11.5	28.6	41	41.0	488	1 DD-S	1 DD-SS	125	120
1 1/4-11.5	37.4	43	47.6	978	1 1/4 DD-S	1 1/4 DD-SS	100	100
1 1/2-11.5	43.4	53	63.5	1889	1 1/2 DD-S	1 1/2 DD-SS	100	100

Do not create drawings from these dimensions, they are subject to change and ISO manufacturing allowances.

DD45 Female thread 45° elbow

Female NPTF* thread (SAE J476)
SAE 140338

*Stainless Steel = NPT to prevent galling

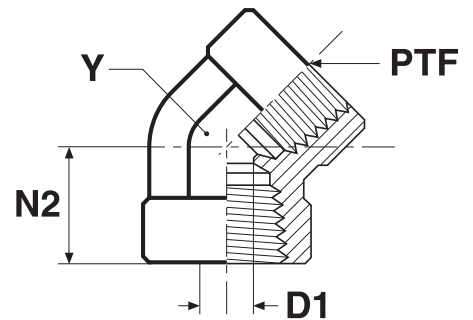

Thread NPT/NPTF PTF	D1 mm	N2 mm	Y mm	Weight (steel) g/1 piece	Adapter Steel	Adapter Stainless Steel	PN (bar)	
							S	SS
1/8-27	8.3	12	14.0	27	1/8 DD45-S	1/8 DD45-SS	350	350
1/4-18	10.7	18	19.0	69	1/4 DD45-S	1/4 DD45-SS	350	350
3/8-18	14.2	19	22.0	97	3/8 DD45-S	3/8 DD45-SS	310	310
1/2-14	17.5	24	27.0	172	1/2 DD45-S	1/2 DD45-SS	210	210
3/4-14	22.8	25	33.3	248	3/4 DD45-S	3/4 DD45-SS	210	210
1-11.5	28.6	30	41.0	479	1 DD45-S	1 DD45-SS	125	120

Order codes shown are part of our current manufacturing programme.

Imperial and metric parts may vary in hexagon dimensions.

$$\frac{PN \text{ (bar)}}{10} = PN \text{ (MPa)}$$

Do not create drawings from these dimensions, they are subject to change and ISO manufacturing allowances.

MMO Female thread tee

Female NPTF* threads (SAE J476)

SAE 140438

*Stainless Steel = NPT to prevent galling

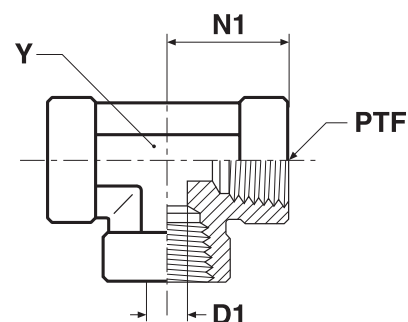

Thread NPT/NPTF PTF	D1 mm	N1 mm	Y mm	Weight (steel) g/1 piece	Adapter Steel	Adapter Stainless Steel	PN (bar)	
							S	SS
1/8-27	8.3	17	14.0	36	1/8 MMO-S	1/8 MMO-SS	350	350
1/4-18	10.7	22	19.0	94	1/4 MMO-S	1/4 MMO-SS	350	350
3/8-18	14.2	26	22.0	121	3/8 MMO-S	3/8 MMO-SS	210	210
1/2-14	17.5	31	27.0	202	1/2 MMO-S	1/2 MMO-SS	210	210
3/4-14	22.8	35	33.3	312	3/4 MMO-S	3/4 MMO-SS	210	210
1-11.5	28.6	41	41.0	606	1 MMO-S	1 MMO-SS	125	120
1 1/4-11.5	37.4	43	47.6	576	1 1/4 MMO-S	1 1/4 MMO-SS	100	100
1 1/2-11.5	43.4	53	63.5	576	1 1/2 MMO-S	1 1/2 MMO-SS	100	100

Do not create drawings from these dimensions, they are subject to change and ISO manufacturing allowances.

KMMOO Female thread cross

Female NPTF* threads (SAE J476)

SAE 140538

*Stainless Steel = NPT to prevent galling

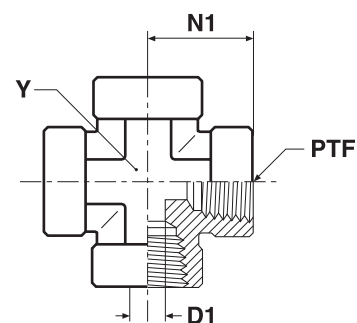

Thread NPT/NPTF PTF	D1 mm	N1 mm	Y mm	Weight (steel) g/1 piece	Adapter Steel	Adapter Stainless Steel	PN (bar)	
							S	SS
1/8-27	8.3	17	14.0	45	1/8 KMMOO-S	1/8 KMMOO-SS	350	350
1/4-18	10.7	22	19.0	113	1/4 KMMOO-S	1/4 KMMOO-SS	350	350
3/8-18	14.2	26	22.0	147	3/8 KMMOO-S	3/8 KMMOO-SS	210	210
1/2-14	17.5	31	27.0	257	1/2 KMMOO-S	1/2 KMMOO-SS	210	210
3/4-14	22.8	35	33.3	382	3/4 KMMOO-S	3/4 KMMOO-SS	210	210
1-11.5	28.6	41	41.0	690	1 KMMOO-S	1 KMMOO-SS	125	120

Order codes shown are part of our current manufacturing programme.

Imperial and metric parts may vary in hexagon dimensions.

$$\frac{\text{PN (bar)}}{10} = \text{PN (MPa)}$$

Do not create drawings from these dimensions, they are subject to change and ISO manufacturing allowances.

Adapters

HP Hexagon head plug

Male NPTF* Thread (SAE J476)

SAE 130109E

*Stainless Steel = NPT to prevent galling

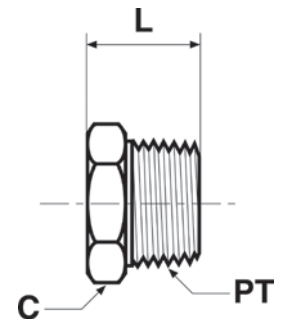

Thread NPT/NPTF PT	C mm	L mm	Weight (steel) g/1 piece	Adapter Steel	Adapter Stainless Steel	PN (bar)	
						S	SS
1/8-27	11.0	14	19	1/8 HP-S	1/8HPMSS	420	420
1/4-18	14.3	19	22	1/4 HP-S	1/4HPMSS	420	420
3/8-18	17.5	20	28	3/8 HP-S	3/8HPMSS	420	420
1/2-14	22.2	24	72	1/2 HP-S	1/2HPMSS	420	420
3/4-14	27.0	27	119	3/4 HP-S	3/4HPMSS	380	380
1-11.5	33.3	32	218	1 HP-S	1HPMSS	380	380
1 1/4-11.5	44.5	36	217	1 1/4 HP-S	1 1/4HPMSS	345	345
1 1/2-11.5	50.8	38	300	1 1/2 HP-S	1 1/2HPMSS	210	210

Do not create drawings from these dimensions, they are subject to change and ISO manufacturing allowances.

HHP Hexagon socket plug

Male NPTF* thread (SAE J476)

SAE 130109N

*Stainless Steel = NPT to prevent galling

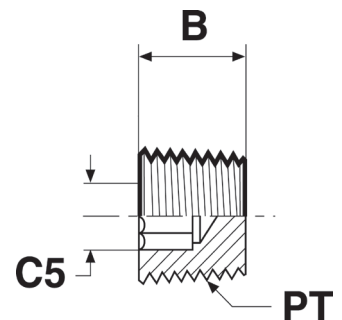

Thread NPT/NPTF PT	B mm	C5 inch	Weight (steel) g/1 piece	Adapter Steel	Adapter Stainless Steel	PN (bar)	
						S	SS
1/16-27	8	5/32	2	1/16 HHP-S	1/16 HHP-SS	420	420
1/8-27	8	3/16	3	1/8 HHP-S	1/8 HHP-SS	420	420
1/4-18	12	1/4	7	1/4 HHP-S	1/4 HHP-SS	420	420
3/8-18	12	5/16	13	3/8 HHP-S	3/8 HHP-SS	420	420
1/2-14	16	3/8	16	1/2 HHP-S	1/2 HHP-SS	420	420
3/4-14	16	9/16	66	3/4 HHP-S	3/4 HHP-SS	380	380
1-11.5	20	5/8	73	1 HHP-S	1 HHP-SS	380	380
1 1/4-11.5	21	3/4	127	1 1/4 HHP-S	1 1/4 HHP-SS	210	345
1 1/2-11.5	21	3/4	168	1 1/2 HHP-S	1 1/2 HHP-SS	210	210
2-11.5	22	3/4	264	2 HHP-S	2 HHP-SS	140	170

Order codes shown are part of our current manufacturing programme.

Imperial and metric parts may vary in hexagon dimensions.

$$\frac{\text{PN (bar)}}{10} = \text{PN (MPa)}$$

Do not create drawings from these dimensions, they are subject to change and ISO manufacturing allowances.

F5OG Male female thread adapter

Male UN/UNF thread – O-ring (ISO 11926) / Female NPTF* thread (SAE 476)

*Stainless Steel = NPT to prevent galling

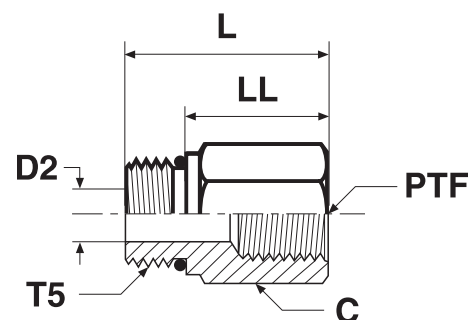

Thread UN/UNF-2A T5	Thread NPT/NPTF PTF	C mm	D2 mm	L mm	LL mm	Weight (steel) g/1 piece	Adapter Steel	Adapter Stainless Steel	PN (bar)	
									S	SS
7/16-20	1/8-27	14.3	4.4	25	16	18	4-1/8 F5OG-S	4-1/8 F5OG-SS	420	420
7/16-20	1/4-18	19.0	4.4	30	20	36	4-1/4 F5OG-S	4-1/4 F5OG-SS	420	420
1/2-20	1/8-27	16.0	6.0	27	18	45	5-1/8 F5OG-S	5-1/8 F5OG-SS	420	420
1/2-20	1/4-18	19.0	6.0	30	21	55	5-1/4 F5OG-S	5-1/4 F5OG-SS	420	420
9/16-18	1/4-18	19.0	7.5	30	20	36	6-1/4 F5OG-S	6-1/4 F5OG-SS	420	420
3/4-16	1/4-18	22.2	9.9	29	18	53	8-1/4 F5OG-S	8-1/4 F5OG-SS	420	420
3/4-16	3/8-18	22.2	9.9	33	21	67	8-3/8 F5OG-S	8-3/8 F5OG-SS	420	420
3/4-16	1/2-14	28.6	9.9	38	27	98	8-1/2 F5OG-S	8-1/2 F5OG-SS	350	350
7/8-14	1/4-18	25.4	12.7	21	8	78	10-1/4 F5OG-S	10-1/4 F5OG-SS	380	380
7/8-14	3/8-18	25.4	12.7	33	21	77	10-3/8 F5OG-S	10-3/8 F5OG-SS	380	380
7/8-14	1/2-14	28.6	12.7	39	26	98	10-1/2 F5OG-S	10-1/2 F5OG-SS	350	350
7/8-14	3/4-14	35.0	12.7	41	29	153	10-3/4 F5OG-S	10-3/4 F5OG-SS	280	280
1 1/16-12	1/2-14	31.8	15.5	36	21	114	12-1/2 F5OG-S	12-1/2 F5OG-SS	350	350
1 1/16-12	3/4-14	35.0	15.5	44	29	150	12-3/4 F5OG-S	12-3/4 F5OG-SS	280	280
1 3/16-12	1/2-14	35.0	18.3	27	12	159	14-1/2 F5OG-S	14-1/2 F5OG-SS	280	280
1 3/16-12	3/4-14	35.0	18.3	43	28	167	14-3/4 F5OG-S	14-3/4 F5OG-SS	280	280
1 5/16-12	1/2-14	38.0	21.4	25	10	137	16-1/2 F5OG-S	16-1/2 F5OG-SS	280	280
1 5/16-12	3/4-14	38.0	21.4	38	23	189	16-3/4 F5OG-S	16-3/4 F5OG-SS	280	280
1 5/16-12	1-11.5	41.3	22.2	48	33	216	16-1 F5OG-S	16-1 F5OG-SS	210	210
1 5/8-12	1-11.5	47.6	27.5	25	10	151	20-1 F5OG-S	20-1 F5OG-SS	210	210
1 5/8-12	1 1/4-11.5	50.8	27.5	50	35	191	20-1 1/4 F5OG-S	20-1 1/4 F5OG-SS	170	170
1 7/8-12	1-11.5	54.0	34.1	25	10	612	24-1 F5OG-S	24-1 F5OG-SS	170	170
1 7/8-12	1 1/2-11.5	57.4	34.1	51	36	653	24-1 1/2 F5OG-S	24-1 1/2 F5OG-SS	140	140

Parker Adapter are delivered with NBR elastomeric seals as standard. For more details on other seal materials see page O60.

Order codes shown are part of our current manufacturing programme.

Imperial and metric parts may vary in hexagon dimensions.

$\frac{\text{PN (bar)}}{10} = \text{PN (MPa)}$

Do not create drawings from these dimensions, they are subject to change and ISO manufacturing allowances.

Adapters

AOEG Elbow

Male UN/UNF thread O-ring (ISO 11926) / Female NPTF thread (SAE 476)

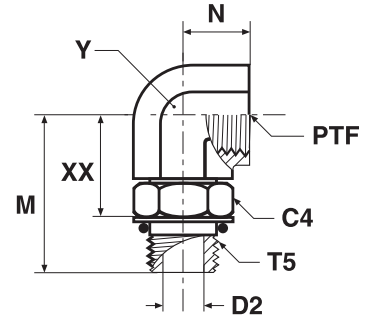

Thread UN/UNF-2A T5	Thread NPTF/NPTF PTF	C4 mm	D2 mm	M mm	N mm	XX mm	Y mm	Weight (steel) g/1 piece	Adapter Steel	PN (bar)
9/16-18	1/4-18	18	7.5	34	16	21	19	86	6-1/4 AOEG-S	350
3/4-16	3/8-18	22	9.9	37	16	24	22	100	8-3/8 AOEG-S	310
7/8-14	1/2-14	25	12.3	46	19	31	27	172	10-1/2 AOEG-S	210
1 1/16-12	3/4-14	32	15.5	51	21	34	33	274	12-3/4 AOEG-S	210
1 5/16-12	1-11.5	38	21.4	57	25	40	41	471	16-1 AOEG-S	125

Do not create drawings from these dimensions, they are subject to change and ISO manufacturing allowances.

AOE4G Extra long elbow

Male UN/UNF thread O-ring (ISO 11926) / Female NPTF thread (SAE 476)

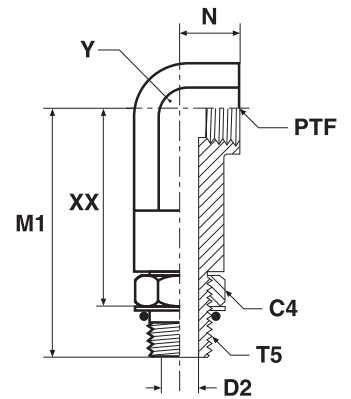

Thread UN/UNF-2A T5	Thread NPTF/NPTF PTF	C4 mm	D2 mm	M1 mm	N mm	XX mm	Y mm	Weight (steel) g/1 piece	Adapter Steel	PN (bar)
3/4-16	3/8-18	22	9.9	75	16	62	22.0	176	8-3/8 AOE4G-S	310
7/8-14	1/2-14	25	12.3	90	19	76	27.0	246	10-1/2 AOE4G-S	210
1 1/16-12	3/4-14	32	15.5	103	21	86	33.3	356	12-3/4 AOE4G-S	210
1 5/16-12	1-11.5	38	21.4	118	25	101	41.0	956	16-1 AOE4G-S	125

Parker Adapter are delivered with NBR elastomeric seals as standard. For more details on other seal materials see page O60.

Order codes shown are part of our current manufacturing programme.

Imperial and metric parts may vary in hexagon dimensions.

$$\frac{PN \text{ (bar)}}{10} = PN \text{ (MPa)}$$

Do not create drawings from these dimensions, they are subject to change and ISO manufacturing allowances.

F5OG5 Thread reducer / Expander

Male UN/UNF threads – O-ring (ISO 11926)
SAE 090136

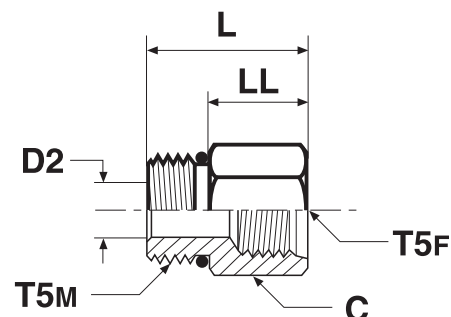

Thread UN/UNF-2A T5M	Thread UN/UNF-2B T5F	C mm	D2 mm	L mm	LL mm	Weight (steel) g/1 piece	Adapter Steel	Adapter Stainless Steel	PN (bar)	
									S	SS
7/16-20	7/16-20	17.5	4.4	27	18	42	4-4 F5OG5-S	4-4 F5OG5-SS	500	315
7/16-20	9/16-18	20.6	4.4	30	20	49	4-6 F5OG5-S	4-6 F5OG5-SS	420	315
9/16-18	7/16-20	17.5	7.5	26	16	30	6-4 F5OG5-S	6-4 F5OG5-SS	500	315
9/16-18	3/4-16	27.0	7.5	35	25	64	6-8 F5OG5-S	6-8 F5OG5-SS	420	280
3/4-16	9/16-18	22.2	9.9	29	18	93	8-6 F5OG5-S	8-6 F5OG5-SS	420	315
3/4-16	7/8-14	28.6	9.9	40	29	73	8-10 F5OG5-S	8-10 F5OG5-SS	310	210
7/8-14	9/16-18	25.4	12.3	32	19	73	10-6 F5OG5-S	10-6 F5OG5-SS	420	350
7/8-14	3/4-16	25.4	12.3	33	21	75	10-8 F5OG5-S	10-8 F5OG5-SS	310	280
7/8-14	1 1/16-12	35.0	12.3	43	30	209	10-12 F5OG5-S	10-12 F5OG5-SS	310	245
1 1/16-12	3/4-16	31.8	15.5	37	22	114	12-8 F5OG5-S	12-8 F5OG5-SS	420	315
1 1/16-12	7/8-14	31.8	15.5	39	24	150	12-10 F5OG5-S	12-10 F5OG5-SS	350	210
1 1/16-12	1 5/16-12	41.3	15.5	48	33	170	12-16 F5OG5-S	12-16 F5OG5-SS	240	140
1 5/16-12	3/4-16	38.0	17.5	25	10	159	16-8 F5OG5-S	16-8 F5OG5-SS	310	310
1 5/16-12	7/8-14	38.0	20.6	25	10	240	16-10 F5OG5-S	16-10 F5OG5-SS	310	245
1 5/16-12	1 1/16-12	38.0	21.4	45	29	259	16-12 F5OG5-S	16-12 F5OG5-SS	310	245
1 5/16-12	1 5/8-12	54.0	21.4	50	35	280	16-20 F5OG5-S	16-20 F5OG5-SS	210	175
1 5/8-12	1 1/16-12	47.6	27.4	25	10	249	20-12 F5OG5-S	20-12 F5OG5-SS	280	210
1 5/8-12	1 5/16-12	47.6	27.4	44	29	249	20-16 F5OG5-S	20-16 F5OG5-SS	280	140
1 7/8-12	1 1/16-12	54.0	24.7	25	10	263	24-12 F5OG5-S	24-12 F5OG5-SS	210	140
1 7/8-12	1 5/16-12	54.0	30.9	25	10	268	24-16 F5OG5-S	24-16 F5OG5-SS	210	140
1 7/8-12	1 5/8-12	54.0	33.3	45	29	272	24-20 F5OG5-S	24-20 F5OG5-SS	210	140

Parker Adapter are delivered with NBR elastomeric seals as standard. For more details on other seal materials see page O60.

Order codes shown are part of our current manufacturing programme.

Imperial and metric parts may vary in hexagon dimensions.

$$\frac{\text{PN (bar)}}{10} = \text{PN (MPa)}$$

Do not create drawings from these dimensions, they are subject to change and ISO manufacturing allowances.

Adapters

F5OHAO Straight thread union

Male UN/UNF threads – O-ring (ISO 11926)

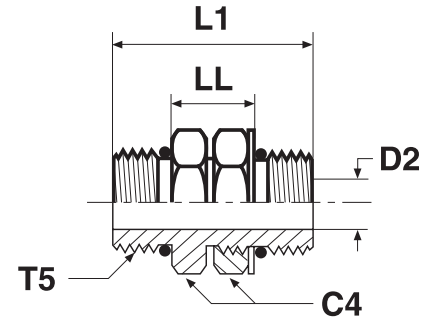

Thread UN/UNF-2A T5	C4 mm	D2 mm	L1 mm	LL mm	Weight (steel) g/1 piece	Adapter Steel	Adapter Stainless Steel	PN (bar)	
								S	SS
7/16-20	14.3	5.2	32	13	25	4 F5OHAO-S	4 F5OHAO-SS	350	350
9/16-18	17.5	7.5	36	14	52	6 F5OHAO-S	6 F5OHAO-SS	350	350
3/4-16	22.2	10.7	42	18	76	8 F5OHAO-S	8 F5OHAO-SS	350	350
7/8-14	25.4	12.3	46	19	118	10 F5OHAO-S	10 F5OHAO-SS	310	310
1 1/16-12	31.8	15.5	54	22	213	12 F5OHAO-S	12 F5OHAO-SS	280	280
1 5/16-12	38.0	21.5	62	30	235	16 F5OHAO-S	16 F5OHAO-SS	210	210
1 5/8-12	47.6	27.4	62	30	367	20 F5OHAO-S	20 F5OHAO-SS	170	170
1 7/8-12	54.0	34.1	62	30	538	24 F5OHAO-S	24 F5OHAO-SS	140	140

Do not create drawings from these dimensions, they are subject to change and ISO manufacturing allowances.

G5G5JG5 Female straight thread tee

Female UN/UNF threads – all 3 ends

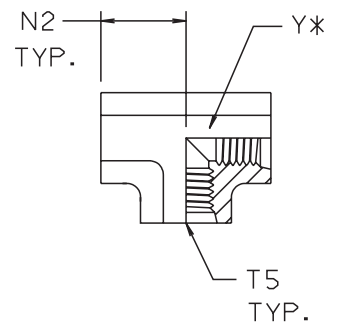

Thread UN/UNF-2B T5	N2 mm	Y mm	Weight (steel) g/1 piece	Adapter Steel	PN (bar)
7/16-20	19	19	68	4 G5G5JG5-S	350
9/16-18	22	22	47	6 G5G5JG5-S	350
3/4-16	26	27	228	8 G5G5JG5-S	350
7/8-14	30	27	228	10 G5G5JG5-S	310

Parker Adapter are delivered with NBR elastomeric seals as standard. For more details on other seal materials see page O60.

Order codes shown are part of our current manufacturing programme.

Imperial and metric parts may vary in hexagon dimensions.

$$\frac{PN \text{ (bar)}}{10} = PN \text{ (MPa)}$$

Do not create drawings from these dimensions, they are subject to change and ISO manufacturing allowances.

P50NM Hexagon head plug

Male UN/UNF thread – O-ring (ISO 11926)
SAE 090109A

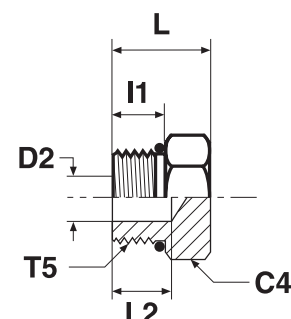

Thread UN/UNF-2A T5	C4 mm	D2 mm	I1 mm	L mm	L2 mm	Weight (steel) g/1 piece	Adapter Steel	Adapter Stainless Steel	PN (bar)	
									S	SS
5/16-24	11.0	2.4	8	15	10	7	2 P50N-S	2P50NMSS	420	420
3/8-24	12.7	3.2	8	15	9	9	3 P50N-S	3P50NMSS	420	420
7/16-20	14.3	5.2	9	17	10	13	4 P50N-S	4P50NMSS	420	420
1/2-20	16.0	5.9	9	17	10	19	5 P50N-S	5P50NMSS	420	420
9/16-18	17.5	7.5	10	19	11	22	6 P50N-S	6P50NMSS	420	420
3/4-16	22.2	10.7	11	20	11	44	8 P50N-S	8P50NMSS	420	420
7/8-14	25.4	12.7	13	24	12	53	10 P50N-S	10P50NMSS	420	420
1 1/16-12	31.8	16.7	15	28	15	117	12 P50N-S	12P50NMSS	420	420
1 3/16-12	35.0	18.2	15	28	14	124	14 P50N-S	14P50NMSS	380	380
1 5/16-12	38.0	22.2	15	28	13	141	16 P50N-S	16P50NMSS	380	380
1 5/8-12	47.6	27.8	15	31	10	284	20 P50N-S	20P50NMSS	280	280
1 7/8-12	54.0	34.1	15	32	9	447	24 P50N-S	24P50NMSS	210	210
2 1/2-12	70.0	46.1	15	36	14	807	32 P50N-S	32P50NMSS	140	140

Parker Adapter are delivered with NBR elastomeric seals as standard. For more details on other seal materials see page O60.

Order codes shown are part of our current manufacturing programme.

Imperial and metric parts may vary in hexagon dimensions.

$$\frac{\text{PN (bar)}}{10} = \text{PN (MPa)}$$

Do not create drawings from these dimensions, they are subject to change and ISO manufacturing allowances.

Adapters

HP50N Hexagon socket plug

Male UN/UNF thread – O-ring (ISO 11926)
SAE 090109B

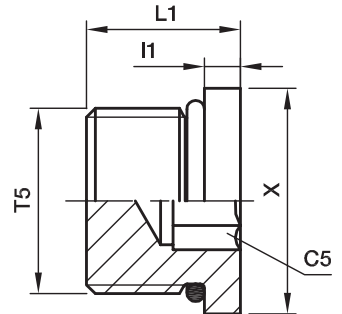

Thread UN/UNF-2A T5	C5 mm	I1 mm	L1 mm	X mm	Weight (steel) g/1 piece	Adapter Steel	Adapter Stainless Steel	PN (bar)	
								S	SS
5/16-24	1/8	3	10	11	5	2 HP50N-S	2 HP50N-SS	420	420
3/8-24	5/32	3	10	13	5	3 HP50N-S	3 HP50N-SS	420	420
7/16-20	3/16	3	12	14	7	4 HP50N-S	4 HP50N-SS	420	420
1/2-20	7/32	3	12	16	10	5 HP50N-S	5 HP50N-SS	420	420
9/16-18	1/4	3	13	18	12	6 HP50N-S	6 HP50N-SS	420	420
3/4-16	5/16	4	15	22	26	8 HP50N-S	8 HP50N-SS	420	420
7/8-14	3/8	4	17	25	39	10 HP50N-S	10 HP50N-SS	420	420
1 1/16-12	9/16	5	20	32	64	12 HP50N-S	12 HP50N-SS	420	420
1 3/16-12	9/16	5	20	35	85	14 HP50N-S	14 HP50N-SS	380	380
1 5/16-12	5/8	5	20	38	103	16 HP50N-S	16 HP50N-SS	380	380
1 5/8-12	3/4	5	20	48	165	20 HP50N-S	20 HP50N-SS	280	280
1 7/8-12	3/4	5	20	54	238	24 HP50N-S	24 HP50N-SS	210	210

Parker Adapter are delivered with NBR elastomeric seals as standard. For more details on other seal materials see page O60.

Order codes shown are part of our current manufacturing programme.

Imperial and metric parts may vary in hexagon dimensions.

$$\frac{\text{PN (bar)}}{10} = \text{PN (MPa)}$$

Do not create drawings from these dimensions, they are subject to change and ISO manufacturing allowances.

F3HG5 Male female thread adapter

Male BSPT thread (ISO 7) / Female UN/UNF thread – O-ring (ISO 11926-1)

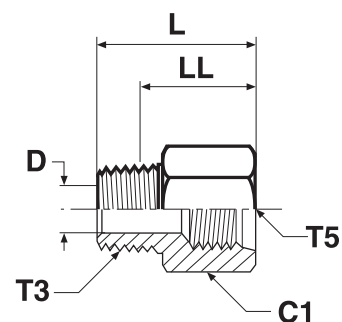

Thread BSPT T3	Thread UN/UNF-2B T5	C1 mm	D mm	L mm	Weight (steel) g/1 piece	Adapter Steel	Adapter Stainless Steel	PN (bar)	
								S	SS
1/8-28	7/16-20	17.5	4.8	28	27	1/8-4F3HG5S	1/8-4F3HMG5SS	350	350
1/8-28	1/2-20	19.0	5.0	28	32	1/8-5F3HG5S	1/8-5F3HMG5SS	350	350
1/4-19	9/16-18	20.6	7.1	35	45	1/4-6F3HG5S	1/4-6F3HMG5SS	350	350
3/8-19	3/4-16	25.4	10.3	37	73	3/8-8F3HG5S	3/8-8F3HMG5SS	315	315
1/2-14	7/8-14	28.6	13.5	45	111	1/2-10F3HG5S	1/2-10F3HMG5SS	210	210
3/4-14	1 1/16-12	35.0	18.3	49	177	3/4-12F3HG5S	3/4-12F3HMG5SS	210	210
1-11	1 5/16-12	41.3	23.8	54	272	1-16F3HG5S	1-16F3HMG5SS	120	120

Order codes shown are part of our current manufacturing programme.

Imperial and metric parts may vary in hexagon dimensions.

$$\frac{\text{PN (bar)}}{10} = \text{PN (MPa)}$$

Do not create drawings from these dimensions, they are subject to change and ISO manufacturing allowances.

Adapters

F4OHG5 Male female thread adapter

Male BSPP thread O-ring + retaining ring (ISO 1179) /
 Female UN/UNF thread – O-ring (ISO 11926-1)

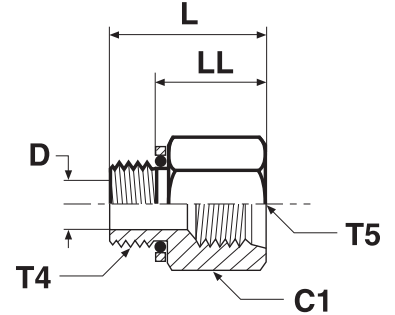

Thread BSPP T4	Thread UN/UNF-2B T5	C1 mm	D mm	L mm	LL mm	Weight (steel) g/1 piece	Adapter Steel	Adapter Stainless Steel	PN (bar)	
									S	SS
1/8-28	7/16-20	17.5	4.4	25	19	27	1/8-4F4OHG5S	1/8-4F4OHMG5SS	350	315
1/4-19	7/16-20	19.0	7.5	28	17	40	1/4-4F4OHG5S	1/4-4F4OHMG5SS	350	315
1/4-19	9/16-18	20.6	7.5	32	22	45	1/4-6F4OHG5S	1/4-6F4OHMG5SS	350	315
3/8-19	9/16-18	22.2	9.9	32	22	70	3/8-6F4OHG5S	3/8-6F4OHMG5SS	350	315
3/8-19	3/4-16	25.4	9.9	34	24	73	3/8-8F4OHG5S	3/8-8F4OHMG5SS	350	280
1/2-14	7/8-14	28.6	12.3	41	28	111	1/2-10F4OHG5S	1/2-10F4OHMG5SS	240	240
3/4-14	1 1/16-12	35.0	15.5	44	32	177	3/4-12F4OHG5S	3/4-12F4OHMG5SS	240	240
1-11	1 5/16-12	44.5	21.4	49	33	272	1-16F4OHG5S	1-16F4OHMG5SS	240	210
1 1/4-11	1 5/8-12	50.8	27.4	50	33	320	1 1/4-20F4OHG5S	1 1/4-20F4OHMG5SS	140	140

Parker Adapter are delivered with NBR elastomeric seals as standard. For more details on other seal materials see page O60.

Order codes shown are part of our current manufacturing programme.

Imperial and metric parts may vary in hexagon dimensions.

$$\frac{PN \text{ (bar)}}{10} = PN \text{ (MPa)}$$

Do not create drawings from these dimensions, they are subject to change and ISO manufacturing allowances.

F8OHG5 Male female thread adapter

Male metric thread O-ring + retaining ring / Female UN/UNF thread – O-ring (ISO 11926-1)

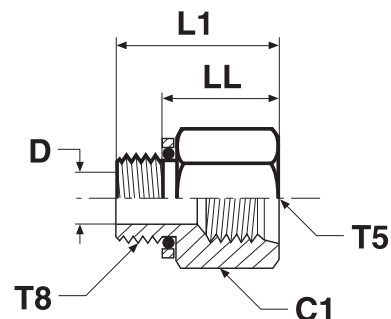

Thread Metric T8	Thread UN/UNF-2B T5	C1 mm	D mm	L1 mm	LL mm	Weight (steel) g/1 piece	Adapter Steel	Adapter Stainless Steel	PN (bar)	
									S	SS
M 10×1.0	7/16-20	17.5	4	27	19	27	M10-4F8OHG5S	M10-4F8OHG5SS	350	315
M 14×1.5	9/16-18	20.6	7	30	22	45	M14-6F8OHG5S	M14-6F8OHG5SS	350	315
M 16×1.5	3/4-16	25.4	9	33	23	73	M16-8F8OHG5S	M16-8F8OHG5SS	350	280
M 22×1.5	7/8-14	28.6	13	38	25	111	M22-10F8OHG5S	M22-10F8OHG5SS	240	210
M 27×2.0	1 1/16-12	35.0	16	48	33	170	M27-12F8OHG5S	M27-12F8OHG5SS	240	210
M 33×2.0	1 5/16-12	41.3	22	49	34	250	M33-16F8OHG5S	M33-16F8OHG5SS	140	140
M 42×2.0	1 5/8-12	50.8	28	49	33	320	M42-20F8OHG5S	M42-20F8OHG5SS	140	140

Parker Adapter are delivered with NBR elastomeric seals as standard. For more details on other seal materials see page O60.

Order codes shown are part of our current manufacturing programme.

Imperial and metric parts may vary in hexagon dimensions.

$$\frac{\text{PN (bar)}}{10} = \text{PN (MPa)}$$

Do not create drawings from these dimensions, they are subject to change and ISO manufacturing allowances.

Adapters

HMK4 Union

BSPP 60° Cone end (ISO 8434-6)

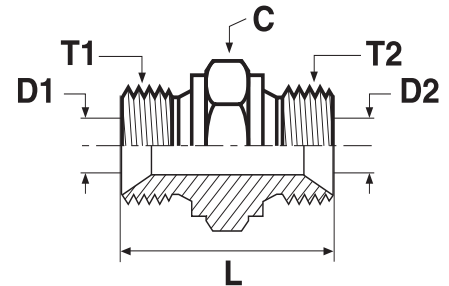

Thread BSPP T1	Thread BSPP T2	C mm	D1 mm	D2 mm	L mm	Weight (steel) g/1 piece	Adapter Steel	Adapter Stainless Steel	PN (bar)	
									S	SS
1/8-28	1/8-28	14	3.5	3.5	24	15	2HMK4S	2HMK4SS	350	350
1/4-19	1/8-28	19	4.7	3.5	28	29	4-2HMK4S	4-2HMK4SS	350	350
1/4-19	1/4-19	19	4.7	4.7	32	35	4HMK4S	4HMK4SS	350	350
3/8-19	1/4-19	22	7.9	4.7	33	46	6-4HMK4S	6-4HMK4SS	350	350
3/8-19	3/8-19	22	7.9	7.9	35	51	6HMK4S	6HMK4SS	350	350
1/2-14	1/4-19	27	11.1	4.7	37	70	8-4HMK4S	8-4HMK4SS	200	200
1/2-14	3/8-19	27	11.1	7.9	38	76	8-6HMK4S	8-6HMK4SS	200	200
1/2-14	1/2-14	27	11.1	11.1	41	85	8HMK4S	8HMK4SS	200	200
5/8-14	1/2-14	30	14.3	11.1	43	106	10-8HMK4S	10-8HMK4SS	200	200
5/8-14	5/8-14	30	14.3	14.3	45	112	10HMK4S	10HMK4SS	200	200
3/4-14	1/4-19	32	16.7	4.7	39	92	12-4HMK4S	12-4HMK4SS	200	200
3/4-14	3/8-19	32	16.7	7.9	41	107	12-6HMK4S	12-6HMK4SS	200	200
3/4-14	1/2-14	32	16.7	11.1	43	111	12-8HMK4S	12-8HMK4SS	200	200
3/4-14	5/8-14	32	16.7	14.3	45	106	12-10HMK4S	12-10HMK4SS	200	200
3/4-14	3/4-14	32	16.7	16.7	45	124	12HMK4S	12HMK4SS	200	200
1-11	1/2-14	41	22.2	11.1	47	175	16-8HMK4S	16-8HMK4SS	120	120
1-11	5/8-14	41	22.2	14.3	49	188	16-10HMK4S	16-10HMK4SS	120	120
1-11	3/4-14	41	22.2	16.7	49	190	16-12HMK4S	16-12HMK4SS	120	120
1-11	1-11	41	22.2	22.2	52	199	16HMK4S	16HMK4SS	120	120
1 1/4-11	3/4-14	50	28.6	16.7	57	259	20-12HMK4S	20-12HMK4SS	105	105
1 1/4-11	1-11	50	28.6	22.2	60	383	20-16HMK4S	20-16HMK4SS	105	105
1 1/4-11	1 1/4-11	50	28.6	28.6	61	405	20HMK4S	20HMK4SS	105	105
1 1/2-11	3/4-14	55	33.3	16.7	61	501	24-12HMK4S	24-12HMK4SS	105	105
1 1/2-11	1-11	55	33.3	22.2	64	417	24-16HMK4S	24-16HMK4SS	105	105
1 1/2-11	1 1/4-11	55	33.3	28.6	65	410	24-20HMK4S	24-20HMK4SS	105	105
1 1/2-11	1 1/2-11	55	33.3	33.3	67	534	24HMK4S	24HMK4SS	105	105
2-11	1 1/2-11	70	46.0	33.3	73	660	32-24HMK4S	32-24HMK4SS	70	70
2-11	2-11	70	46.0	46.0	76	719	32HMK4S	32HMK4SS	70	70

Order codes shown are part of our current manufacturing programme.

Imperial and metric parts may vary in hexagon dimensions.

$$\frac{\text{PN (bar)}}{10} = \text{PN (MPa)}$$

Do not create drawings from these dimensions, they are subject to change and ISO manufacturing allowances.

WMK4WL4NM Bulkhead union

BSPP 60° Cone end (ISO 8434-6)

*Supplied with locknut

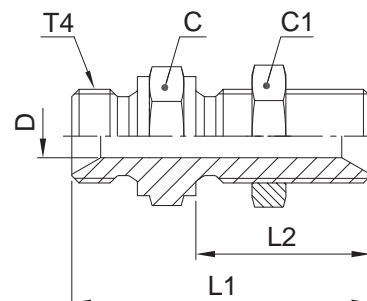

Thread BSPP T4	L1 mm	L2 mm	C mm	C1 mm	D mm	Weight (steel) g/1 piece	Adapter Steel	Adapter Stainless Steel	PN (bar)	
									S	SS
1/4-19	49	28	19	19	4.7	57	4WMK4WL4NMS	4WMK4WL4NMSS	350	350
3/8-19	55	32	22	22	7.9	84	6WMK4WL4NMS	6WMK4WL4NMSS	350	350
1/2-14	62	35	27	27	11.1	122	8WMK4WL4NMS	8WMK4WL4NMSS	200	200
5/8-14	64	35	30	30	14.3	146	10WMK4WL4NMS	10WMK4WL4NMSS	200	200
3/4-14	67	38	32	36	16.7	209	12WMK4WL4NMS	12WMK4WL4NMSS	200	200
1-11	74	41	41	41	22.2	328	16WMK4WL4NMS	16WMK4WL4NMSS	120	120
1 1/4-11	85	44	50	50	28.6	507	20WMK4WL4NMS	20WMK4WL4NMSS	105	105
1 1/2-11	93	48	55	55	33.3	609	24WMK4WL4NMS	24WMK4WL4NMSS	105	105

Order codes shown are part of our current manufacturing programme.

Imperial and metric parts may vary in hexagon dimensions.

For the version without locknut, please delete "WL4NM" (e.g. 16WMK4)

$\frac{\text{PN (bar)}}{10} = \text{PN (MPa)}$

Do not create drawings from these dimensions, they are subject to change and ISO manufacturing allowances.

Maximum bulkhead wallthickness

Thread BSPP	Bulkhead union Max. thickness mm
1/4	9.5
3/8	12.5
1/2	12.4
5/8	10.8
3/4	13.4
1	10.1
1 1/4	12.1
1 1/2	14.1

Adapters

EMK4 Union elbow

BSPP 60° Cone end (ISO 8434-6)

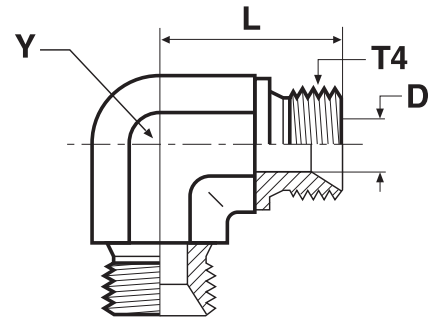

Thread BSPP T4	D mm	L mm	Y mm	Weight (steel) g/1 piece	Adapter Steel	Adapter Stainless Steel	PN (bar)	
							S	SS
1/8-28	3.5	17	11	21	2EMK4S	2EMK4SS	350	350
1/4-19	4.7	24	14	45	4EMK4S	4EMK4SS	350	350
3/8-19	7.9	27	19	85	6EMK4S	6EMK4SS	350	350
1/2-14	11.1	32	22	123	8EMK4S	8EMK4SS	200	200
5/8-14	14.3	34	22	109	10EMK4S	10EMK4SS	200	200
3/4-14	16.7	36	27	178	12EMK4S	12EMK4SS	200	200
1-11	22.2	42	33	288	16EMK4S	16EMK4SS	120	120
1 1/4-11	28.6	48	41	512	20EMK4S	20EMK4SS	105	105
1 1/2-11	33.3	54	48	824	24EMK4S	24EMK4SS	105	105

Do not create drawings from these dimensions, they are subject to change and ISO manufacturing allowances.

JMK4 Union tee

BSPP 60° Cone end (ISO 8434-6)

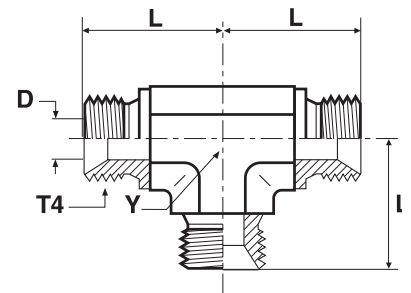

Thread BSPP T4	D mm	L mm	Y mm	Weight (steel) g/1 piece	Adapter Steel	Adapter Stainless Steel	PN (bar)	
							S	SS
1/8-28	3.5	17	11	33	2JMK4S	2JMK4SS	350	350
1/4-19	4.7	24	14	61	4JMK4S	4JMK4SS	350	350
3/8-19	7.9	27	19	105	6JMK4S	6JMK4SS	350	350
1/2-14	11.1	32	22	157	8JMK4S	8JMK4SS	200	200
5/8-14	14.3	34	22	145	10JMK4S	10JMK4SS	200	200
3/4-14	16.7	36	27	258	12JMK4S	12JMK4SS	200	200
1-11	22.2	42	33	591	16JMK4S	16JMK4SS	120	120
1 1/4-11	28.6	48	41	646	20JMK4S	20JMK4SS	105	105
1 1/2-11	33.3	54	48	940	24JMK4S	24JMK4SS	105	105

Order codes shown are part of our current manufacturing programme.

Imperial and metric parts may vary in hexagon dimensions.

$$\frac{\text{PN (bar)}}{10} = \text{PN (MPa)}$$

Do not create drawings from these dimensions, they are subject to change and ISO manufacturing allowances.

PNMK4 Plug

BSPP 60° Cone plug (ISO 8434-6)

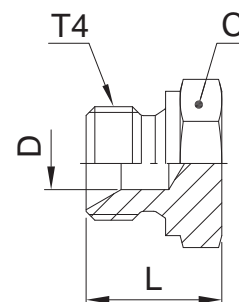

Thread BSPP T4	C mm	D mm	L mm	Weight (steel) g/1 piece	Adapter Steel	Adapter Stainless Steel	PN (bar)	
							S	SS
1/8-28	14	3.5	14	11	2PNMK4S	2PNMK4SS	350	350
1/4-19	19	4.7	19	22	4PNMK4S	4PNMK4SS	350	350
3/8-19	22	7.9	21	38	6PNMK4S	6PNMK4SS	350	350
1/2-14	27	11.1	24	66	8PNMK4S	8PNMK4SS	200	200
5/8-14	30	14.3	27	76	10PNMK4S	10PNMK4SS	200	200
3/4-14	32	16.7	27	106	12PNMK4S	12PNMK4SS	200	200
1-11	41	22.2	30	170	16PNMK4S	16PNMK4SS	120	120
1 1/4-11	50	28.6	39	316	20PNMK4S	20PNMK4SS	105	105
1 1/2-11	55	33.3	43	386	24PNMK4S	24PNMK4SS	105	105
2-11	70	46.0	48	650	32PNMK4S	32PNMK4SS	70	70

Order codes shown are part of our current manufacturing programme.

Imperial and metric parts may vary in hexagon dimensions.

$$\frac{\text{PN (bar)}}{10} = \text{PN (MPa)}$$

Do not create drawings from these dimensions, they are subject to change and ISO manufacturing allowances.

Adapters

F6MK4 Swivel male stud

BSPP 60° cone end (ISO 8434-6) / BSPP 60° Female swivel end (ISO 8434-6)

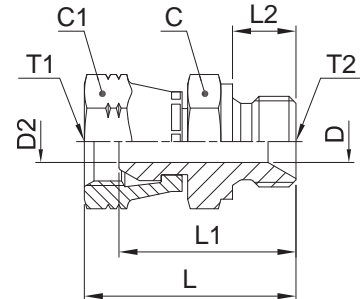

Thread BSPP T1	Thread BSPP T2	C mm	C1 mm	D mm	D2 mm	L mm	L1 mm	L2 mm	Weight (steel) g/1 piece	Adapter Steel	Adapter Stainless Steel	PN (bar)	
												S	SS
1/4-19	1/4-19	19	19	4.7	4.7	37	31	11	44	4-4F6MK4S	4-4F6MK4SS	350	350
1/4-19	3/8-19	22	19	7.9	4.7	39	34	12	61	4-6F6MK4S	4-6F6MK4SS	350	350
1/4-19	1/2-14	27	19	11.1	4.7	42	36	14	75	4-8F6MK4S	4-8F6MK4SS	200	200
3/8-19	1/4-19	19	22	4.7	4.7	38	32	11	59	6-4F6MK4S	6-4F6MK4SS	350	350
3/8-19	3/8-19	22	22	7.9	7.9	40	34	12	71	6-6F6MK4S	6-6F6MK4SS	350	350
3/8-19	1/2-14	27	22	11.1	7.9	44	37	14	92	6-8F6MK4S	6-8F6MK4SS	200	200
1/2-14	3/8-19	22	27	7.9	7.9	44	37	12	102	8-6F6MK4S	8-6F6MK4SS	200	200
1/2-14	1/2-14	27	27	11.1	11.1	46	39	14	143	8-8F6MK4S	8-8F6MK4SS	200	200
1/2-14	3/4-14	32	27	16.7	11.1	49	42	16	157	8-12F6MK4S	8-12F6MK4SS	200	200
3/4-14	1/2-14	27	32	11.1	11.1	48	39	14	171	12-8F6MK4S	12-8F6MK4SS	200	200
3/4-14	3/4-14	32	32	16.7	16.7	50	41	16	165	12-12F6MK4S	12-12F6MK4SS	200	200
3/4-14	1-11	41	32	22.2	16.7	54	45	19	261	12-16F6MK4S	12-16F6MK4SS	120	120
1-11	3/4-14	32	41	16.7	16.7	54	43	16	250	16-12F6MK4S	16-12F6MK4SS	120	120
1-11	1-11	41	41	22.2	22.2	57	46	19	300	16-16F6MK4S	16-16F6MK4SS	120	120
1-11	1-11	50	50	28.6	28.6	71	61	20	528	20-20F6MK4S	20-20F6MK4SS	120	120

Order codes shown are part of our current manufacturing programme.

Imperial and metric parts may vary in hexagon dimensions.

$$\frac{\text{PN (bar)}}{10} = \text{PN (MPa)}$$

Do not create drawings from these dimensions, they are subject to change and ISO manufacturing allowances.

C6MK4 Swivel nut elbow

BSPP 60° cone end (ISO 8434-6) / BSPP 60° Female swivel end (ISO 8434-6)

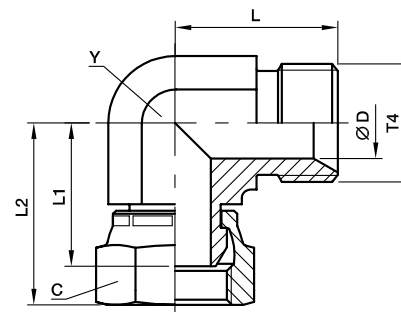

Thread BSPP T4	C mm	D mm	L mm	L1 mm	L2 mm	Y mm	Weight (steel) g/1 piece	Adapter Steel	Adapter Stainless Steel	PN (bar)	
										S	SS
1/8-28	14	3.5	17	18	23	11	26	2C6MK4S	2C6MK4SS	350	350
1/4-19	19	4.7	24	25	31	14	62	4C6MK4S	4C6MK4SS	350	350
3/8-19	22	7.9	27	26	33	19	104	6C6MK4S	6C6MK4SS	350	350
1/2-14	27	11.1	32	32	39	22	159	8C6MK4S	8C6MK4SS	200	200
5/8-14	30	14.3	34	30	40	22	158	10C6MK4S	10C6MK4SS	200	200
3/4-14	32	16.7	36	33	42	27	226	12C6MK4S	12C6MK4SS	200	200
1-11	41	22.2	42	38	49	33	377	16C6MK4S	16C6MK4SS	120	120
1 1/4-11	50	28.6	48	48	58	41	650	20C6MK4S	20C6MK4SS	105	105
1 1/2-11	60	33.3	54	50	63	48	999	24C6MK4S	24C6MK4SS	105	105

Order codes shown are part of our current manufacturing programme.

Imperial and metric parts may vary in hexagon dimensions.

$$\frac{\text{PN (bar)}}{10} = \text{PN (MPa)}$$

Do not create drawings from these dimensions, they are subject to change and ISO manufacturing allowances.

Adapters

R6MK4 Swivel nut run tee

BSPP 60° Cone ends (ISO 8434-6) / BSPP 60° Female swivel end (ISO 8434-6)

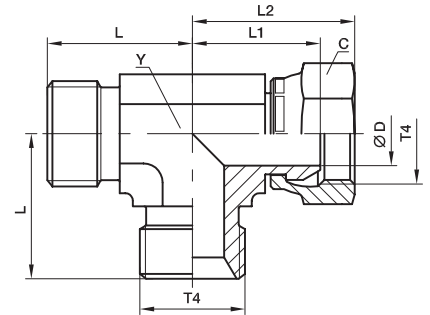

Thread BSPP T4	C mm	D mm	L mm	L1 mm	L2 mm	Y mm	Weight (steel) g/1 piece	Adapter Steel	Adapter Stainless Steel	PN (bar)	
										S	SS
1/8-28	14	3.5	17	18	23	11	29	2R6MK4S	2R6MK4SS	350	350
1/4-19	19	4.7	24	25	31	14	77	4R6MK4S	4R6MK4SS	350	350
3/8-19	22	7.9	27	26	33	19	128	6R6MK4S	6R6MK4SS	350	350
1/2-14	27	11.1	32	32	39	22	203	8R6MK4S	8R6MK4SS	200	200
5/8-14	30	14.3	34	30	40	22	274	10R6MK4S	10R6MK4SS	200	200
3/4-14	32	16.7	36	33	42	27	274	12R6MK4S	12R6MK4SS	200	200
1-11	41	22.2	42	38	49	33	456	16R6MK4S	16R6MK4SS	120	120
1 1/4-11	50	28.6	48	48	58	41	801	20R6MK4S	20R6MK4SS	105	105

Order codes shown are part of our current manufacturing programme.

Imperial and metric parts may vary in hexagon dimensions.

$$\frac{\text{PN (bar)}}{10} = \text{PN (MPa)}$$

Do not create drawings from these dimensions, they are subject to change and ISO manufacturing allowances.

S6MK4 Swivel nut branch tee

BSPP 60° Cone ends (ISO 8434-6) / BSPP 60° Female swivel end (ISO 8434-6)

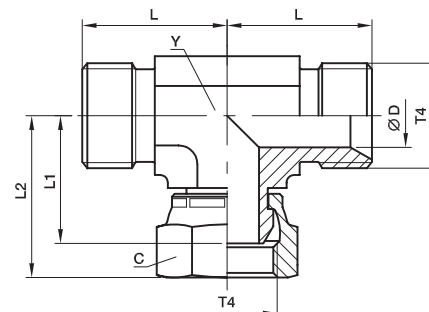

Thread BSPP T4	C mm	D mm	L mm	L1 mm	L2 mm	Y mm	Weight (steel) g/1 piece	Adapter Steel	Adapter Stainless Steel	PN (bar)	
										S	SS
1/8-28	14	3.5	17	18	23	11	33	2S6MK4S	2S6MK4SS	350	350
1/4-19	19	4.7	24	25	31	14	77	4S6MK4S	4S6MK4SS	350	350
3/8-19	22	7.9	27	26	33	19	126	6S6MK4S	6S6MK4SS	350	350
1/2-14	27	11.1	32	32	39	22	191	8S6MK4S	8S6MK4SS	200	200
5/8-14	30	14.3	34	30	40	22	209	10S6MK4S	10S6MK4SS	200	200
3/4-14	32	16.7	36	33	42	27	286	12S6MK4S	12S6MK4SS	200	200
1-11	41	22.2	42	38	49	33	493	16S6MK4S	16S6MK4SS	120	120
1 1/4-11	50	28.6	48	48	58	41	796	20S6MK4S	20S6MK4SS	105	105

Order codes shown are part of our current manufacturing programme.

Imperial and metric parts may vary in hexagon dimensions.

$\frac{\text{PN (bar)}}{10} = \text{PN (MPa)}$

Do not create drawings from these dimensions, they are subject to change and ISO manufacturing allowances.

Adapters

H6MK4 Swivel nut union

BSPP 60° Female swivel ends (ISO 8434-6)

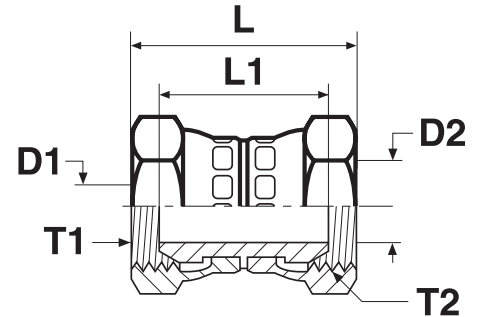

Thread BSPP T1	Thread BSPP T2	D1 mm	D2 mm	L mm	L1 mm	Weight (steel) g/1 piece	Adapter Steel	Adapter Stainless Steel	PN (bar)	
									S	SS
1/4-19	1/4-19	4.7	4.7	38	27	50	4H6MK4S	4H6MK4SS	350	350
3/8-19	1/4-19	7.9	4.7	40	28	61	6-4H6MK4S	6-4H6MK4SS	350	350
3/8-19	3/8-19	7.9	7.9	42	29	73	6H6MK4S	6H6MK4SS	350	350
1/2-14	1/4-19	11.1	4.7	43	30	85	8-4H6MK4S	8-4H6MK4SS	200	200
1/2-14	3/8-19	11.1	7.9	44	31	96	8-6H6MK4S	8-6H6MK4SS	200	200
1/2-14	1/2-14	11.1	11.1	47	33	107	8H6MK4S	8H6MK4SS	200	200
5/8-14	5/8-14	14.3	14.3	48	29	130	10H6MK4S	10H6MK4SS	200	200
3/4-14	1/2-14	16.7	11.1	49	33	152	12-8H6MK4S	12-8H6MK4SS	200	200
3/4-14	3/4-14	16.7	16.7	50	32	167	12H6MK4S	12H6MK4SS	200	200
1-11	1-11	22.2	22.2	57	35	201	16H6MK4S	16H6MK4SS	120	120
1 1/4-11	1 1/4-11	28.6	28.6	66	45	340	20H6MK4S	20H6MK4SS	105	105
1 1/2-11	1 1/2-11	33.3	33.3	70	43	583	24H6MK4S	24H6MK4SS	105	105

Order codes shown are part of our current manufacturing programme.

Imperial and metric parts may vary in hexagon dimensions.

$$\frac{\text{PN (bar)}}{10} = \text{PN (MPa)}$$

Do not create drawings from these dimensions, they are subject to change and ISO manufacturing allowances.

E6MK4 Swivel nut elbow

BSPP 60° Female swivel ends (ISO 8434-6)

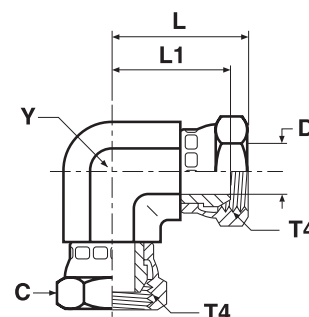

Thread BSPP T4	C mm	D mm	L mm	L1 mm	Y mm	Weight (steel) g/1 piece	Adapter Steel	Adapter Stainless Steel	PN (bar)	
									S	SS
1/4-19	19	4.7	31	25	14	90	4E6MK4S	4E6MK4SS	350	350
3/8-19	22	7.9	33	26	19	127	6E6MK4S	6E6MK4SS	350	350
1/2-14	27	11.1	39	32	22	225	8E6MK4S	8E6MK4SS	200	200
5/8-14	30	14.3	39	30	22	203	10E6MK4S	10E6MK4SS	200	200
3/4-14	32	16.7	42	33	27	263	12E6MK4S	12E6MK4SS	200	200
1-11	41	22.2	49	38	33	667	16E6MK4S	16E6MK4SS	120	120
1 1/4-11	50	28.6	58	48	41	795	20E6MK4S	20E6MK4SS	105	105
1 1/2-11	60	33.3	63	50	48	1219	24E6MK4S	24E6MK4SS	105	105

Order codes shown are part of our current manufacturing programme.

Imperial and metric parts may vary in hexagon dimensions.

$$\frac{\text{PN (bar)}}{10} = \text{PN (MPa)}$$

Do not create drawings from these dimensions, they are subject to change and ISO manufacturing allowances.

Adapters

J6MK4 Swivel nut tee

BSPP 60° Female swivel ends (ISO 8434-6)

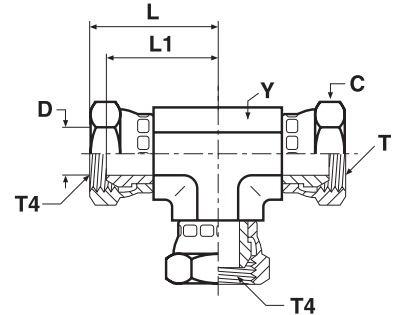

Thread BSPP T4	C mm	D mm	L mm	L1 mm	Y mm	Weight (steel) g/1 piece	Adapter Steel	Adapter Stainless Steel	PN (bar)	
									S	SS
1/4-19	19	4.7	31	25	14	119	4J6MK4S	4J6MK4SS	350	350
3/8-19	22	7.9	33	26	19	195	6J6MK4S	6J6MK4SS	350	350
1/2-14	27	11.1	39	32	22	267	8J6MK4S	8J6MK4SS	200	200
5/8-14	30	14.3	39	30	22	300	10J6MK4S	10J6MK4SS	200	200
3/4-14	32	16.7	42	33	27	398	12J6MK4S	12J6MK4SS	200	200
1-11	41	22.2	49	38	33	620	16J6MK4S	16J6MK4SS	120	120
1 1/4-11	50	28.6	58	48	41	1050	20J6MK4S	20J6MK4SS	105	105

Order codes shown are part of our current manufacturing programme.

Imperial and metric parts may vary in hexagon dimensions.

$$\frac{\text{PN (bar)}}{10} = \text{PN (MPa)}$$

Do not create drawings from these dimensions, they are subject to change and ISO manufacturing allowances.

G4MK4 Female connector

BSPP 60° Cone end (ISO8434-6) / Female BSPP thread (ISO1179-1)

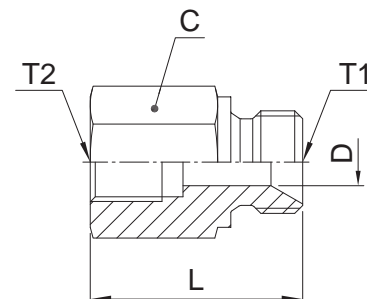

Thread BSPP T1	Thread BSPP T2	C mm	D mm	L mm	Weight (steel) g/1 piece	Adapter Steel	Adapter Stainless Steel	PN (bar)	
								S	SS
1/4-19	1/4-19	19	4.7	34	47	4-4G4MK4S	4-4G4MK4SS	350	350
3/8-19	1/4-19	22	7.9	36	74	6G4MK4S	6G4MK4SS	350	350
3/8-19	3/8-19	27	7.9	35	75	6-6G4MK4S	6-6G4MK4SS	200	200
1/2-14	1/4-19	27	11.1	38	77	8-4G4MK4S	8-4G4MK4SS	200	200
1/2-14	3/8-19	27	11.1	40	102	8G4MK4S	8G4MK4SS	200	200
1/2-14	1/2-14	27	11.1	46	120	8-8G4MK4S	8-8G4MK4SS	200	200
3/4-14	1/4-19	32	16.7	40	180	12-4G4MK4S	12-4G4MK4SS	200	200
3/4-14	3/8-19	32	16.7	42	167	12-6G4MK4S	12-6G4MK4SS	200	200
3/4-14	1/2-14	32	16.7	48	209	12-8G4MK4S	12-8G4MK4SS	200	200
3/4-14	3/4-14	36	16.7	46	188	12G4MK4S	12G4MK4SS	200	200
1-11	1/4-19	41	22.2	43	298	16-4G4MK4S	16-4G4MK4SS	120	120
1-11	3/8-19	41	22.2	45	287	16-6G4MK4S	16-6G4MK4SS	120	120
1-11	1/2-14	41	22.2	51	275	16-8G4MK4S	16-8G4MK4SS	120	120
1-11	3/4-14	41	22.2	52	360	16-12G4MK4S	16-12G4MK4SS	120	120

Order codes shown are part of our current manufacturing programme.

Imperial and metric parts may vary in hexagon dimensions.

$$\frac{\text{PN (bar)}}{10} = \text{PN (MPa)}$$

Do not create drawings from these dimensions, they are subject to change and ISO manufacturing allowances.

Adapters

F3MK4 Male stud connector

BSPP 60° Cone end (ISO 8434-6) / Male BSPT thread (ISO 7)

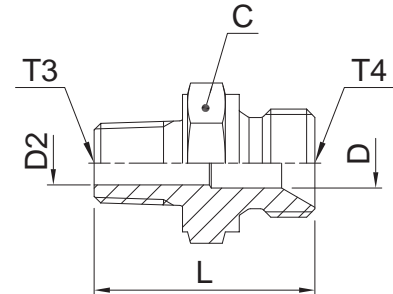

Thread BSPP T4	Thread BSPT T3	C mm	D mm	D2 mm	L mm	Weight (steel) g/1 piece	Adapter Steel	Adapter Stainless Steel	PN (bar)	
									S	SS
1/8-28	1/8-28	14	3.5	3.5	25	15	2F3MK4S	2F3MK4SS	315	315
1/8-28	1/4-19	14	3.5	7.0	29	28	2-4F3MK4S	2-4F3MK4SS	315	315
1/4-19	1/4-19	19	4.7	4.7	34	31	4-4F3MK4S	4-4F3MK4SS	315	315
1/4-19	1/8-28	19	4.7	4.7	29	27	4F3MK4S	4F3MK4SS	315	315
1/4-19	3/8-19	19	4.7	10.0	34	44	4-6F3MK4S	4-6F3MK4SS	315	315
3/8-19	3/8-19	22	7.9	7.9	35	52	6-6F3MK4S	6-6F3MK4SS	315	315
3/8-19	1/2-14	22	7.9	13.5	40	68	6-8F3MK4S	6-8F3MK4SS	160	160
3/8-19	1/4-19	22	7.9	7.0	35	48	6F3MK4S	6F3MK4SS	315	315
1/2-14	1/2-14	27	11.1	11.1	44	79	8-8F3MK4S	8-8F3MK4SS	160	160
1/2-14	3/8-19	27	11.1	10.0	39	68	8F3MK4S	8F3MK4SS	200	200
5/8-14	1/2-14	30	14.3	13.5	46	101	10F3MK4S	10F3MK4SS	200	200
5/8-14	3/4-14	30	14.3	14.3	47	102	10-12F3MK4S	10-12F3MK4SS	160	160
3/4-14	1/2-14	32	16.7	13.5	46	111	12-8F3MK4S	12-8F3MK4SS	315	315
3/4-14	3/4-14	32	16.7	16.7	46	126	12F3MK4S	12F3MK4SS	160	160
3/4-14	1-14	36	16.7	24.0	51	242	12-16F3MK4S	12-16F3MK4SS	120	120
1-11	3/4-14	41	22.2	18.0	50	173	16-12F3MK4S	16-12F3MK4SS	120	120
1-11	1-11	41	22.2	22.2	55	219	16F3MK4S	16F3MK4SS	120	120
1 1/4-11	1 1/4-11	50	28.6	32.0	64	337	20F3MK4S	20F3MK4SS	105	105
1 1/2-11	1 1/2-11	55	33.3	33.3	69	497	24F3MK4S	24F3MK4SS	105	105

Order codes shown are part of our current manufacturing programme.

Imperial and metric parts may vary in hexagon dimensions.

$$\frac{\text{PN (bar)}}{10} = \text{PN (MPa)}$$

Do not create drawings from these dimensions, they are subject to change and ISO manufacturing allowances.

FNMK4 Cap

BSPP 60° Cone female swivel cap end

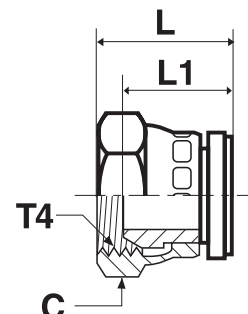

Thread BSPP T4	C mm	L mm	L1 mm	Weight (steel) g/1 piece	Adapter Steel	Adapter Stainless Steel	PN (bar)	
							S	SS
1/8-28	14	16	11	19	2FNMK4S	2FNMK4SS	350	350
1/4-19	19	20	15	23	4FNMK4S	4FNMK4SS	350	350
3/8-19	22	22	15	43	6FNMK4S	6FNMK4SS	350	350
1/2-14	27	25	18	64	8FNMK4S	8FNMK4SS	200	200
5/8-14	30	25	16	80	10FNMK4S	10FNMK4SS	200	200
3/4-14	32	26	17	115	12FNMK4S	12FNMK4SS	200	200
1-11	41	30	19	154	16FNMK4S	16FNMK4SS	120	120
1 1/4-11	50	34	24	345	20FNMK4S	20FNMK4SS	105	105
1 1/2-11	60	36	23	500	24FNMK4S	24FNMK4SS	105	105

Order codes shown are part of our current manufacturing programme.

Imperial and metric parts may vary in hexagon dimensions.

$$\frac{\text{PN (bar)}}{10} = \text{PN (MPa)}$$

Do not create drawings from these dimensions, they are subject to change and ISO manufacturing allowances.

Adapters

FMK4 Male stud connector

BSPP 60° Cone end (ISO 8434-6) / Male NPTF* thread (SAE J476)

*Stainless Steel = NPT to prevent galling

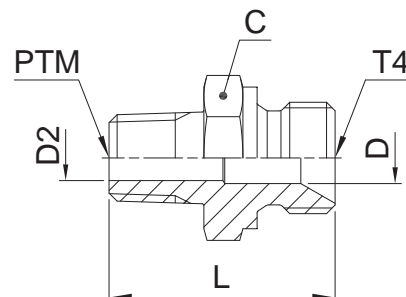

Thread BSPP T4	Thread NPT/NPTF PTM	C mm	D mm	D2 mm	L mm	Weight (steel) g/1 piece	Adapter Steel	Adapter Stainless Steel	PN (bar)	
									S	SS
1/8-28	1/8-27	14	3.5	3.5	24	17	2FMK4S	2FMK4SS	350	350
1/8-28	1/4-18	14	3.5	3.5	29	21	2-4FMK4S	2-4FMK4SS	350	350
1/4-19	1/8-27	19	4.7	4.7	29	24	4FMK4S	4FMK4SS	350	350
1/4-19	1/4-18	19	4.7	4.7	33	33	4-4FMK4S	4-4FMK4SS	350	350
1/4-19	3/8-18	19	4.7	4.7	33	41	4-6FMK4S	4-6FMK4SS	350	350
1/4-19	1/2-14	22	4.7	4.7	40	80	4-8FMK4S	4-8FMK4SS	350	350
3/8-19	1/4-18	22	7.9	7.0	35	45	6FMK4S	6FMK4SS	350	350
3/8-19	3/8-18	22	7.9	7.9	35	50	6-6FMK4S	6-6FMK4SS	350	350
3/8-19	1/2-14	22	7.9	7.9	40	77	6-8FMK4S	6-8FMK4SS	350	350
1/2-14	3/8-18	27	11.1	10.0	39	48	8FMK4S	8FMK4SS	200	200
1/2-14	1/2-14	27	11.1	11.1	43	93	8-8FMK4S	8-8FMK4SS	200	200
1/2-14	3/4-14	27	11.1	11.1	43	95	8-12FMK4S	8-12FMK4SS	200	200
3/4-14	1/2-14	32	16.7	13.5	46	112	12-8FMK4S	12-8FMK4SS	200	200
3/4-14	3/4-14	32	16.7	16.7	46	124	12FMK4S	12FMK4SS	200	200
3/4-14	1-11 1/2	36	16.7	16.7	51	150	12-16FMK4S	12-16FMK4SS	200	200
1-11	3/4-14	41	22.2	18.0	50	188	16-12FMK4S	16-12FMK4SS	120	120
1-11	1-11 1/2	41	22.2	22.2	55	234	16FMK4S	16FMK4SS	120	120
1 1/4-11	1 1/4-11 1/2	50	28.6	28.6	64	360	20FMK4S	20FMK4SS	105	105
1 1/2-11	1 1/2-11 1/2	55	33.3	38.0	69	510	24FMK4S	24FMK4SS	105	105

Order codes shown are part of our current manufacturing programme.

Imperial and metric parts may vary in hexagon dimensions.

$$\frac{\text{PN (bar)}}{10} = \text{PN (MPa)}$$

Do not create drawings from these dimensions, they are subject to change and ISO manufacturing allowances.

GG44M Female thread coupling

Female BSPP thread (ISO 1179-1)

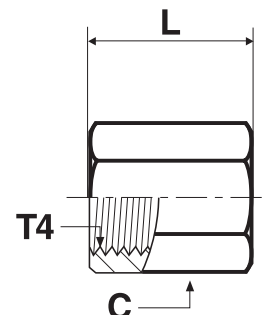

Thread BSPP T4	C mm	L mm	Weight (steel) g/1 piece	Adapter Steel	Adapter Stainless Steel	PN (bar)	
						S	SS
1/8-28	14	19	16	1/8GG44MS	1/8GG44MSS	420	420
1/4-19	17	28	30	1/4GG44MS	1/4GG44MSS	420	420
3/8-19	22	28	47	3/8GG44MS	3/8GG44MSS	420	420
1/2-14	27	33	78	1/2GG44MS	1/2GG44MSS	350	350
3/4-14	32	37	105	3/4GG44MS	3/4GG44MSS	280	280
1-11	46	42	341	1GG44MS	1GG44MSS	210	210

Order codes shown are part of our current manufacturing programme.

Imperial and metric parts may vary in hexagon dimensions.

$$\frac{\text{PN (bar)}}{10} = \text{PN (MPa)}$$

Do not create drawings from these dimensions, they are subject to change and ISO manufacturing allowances.

Adapters

MMO444M Female thread tee

Female BSPP threads (ISO 1179-1)

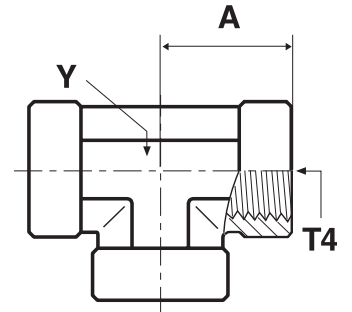

Thread BSPP T4	A mm	Y mm	Weight (steel) g/1 piece	Adapter Steel	PN (bar)
1/4-19	22	19	74	1/4MMO444MS	350
3/8-19	26	22	111	3/8MMO444MS	315
1/2-14	31	27	177	1/2MMO444MS	210
3/4-14	40	33	294	3/4MMO444MS	210
1-11	46	41	567	1MMO444MS	120

Order codes shown are part of our current manufacturing programme.

Imperial and metric parts may vary in hexagon dimensions.

$$\frac{\text{PN (bar)}}{10} = \text{PN (MPa)}$$

Do not create drawings from these dimensions, they are subject to change and ISO manufacturing allowances.

PTR34M Thread reducer

Male BSPT thread (ISO 7) / Female BSPP thread (ISO 1179-1)

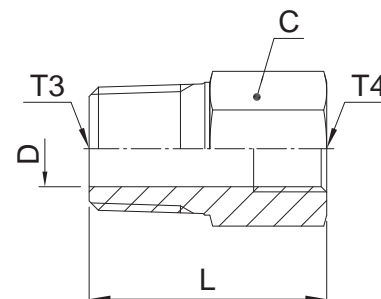

Thread BSPT T3	Thread BSPP T4	C mm	D mm	L mm	Weight (steel) g/1 piece	Adapter Steel	Adapter Stainless Steel	PN (bar)	
								S	SS
1/4-19	1/8-28	14	7.0	28	16	1/4X1/8PTR34MS	1/4X1/8PTR34MSS	315	315
3/8-19	1/4-19	19	10.0	33	44	3/8X1/4PTR34MS	3/8X1/4PTR34MSS	315	315
1/2-14	1/4-19	22	11.7	39	71	1/2X1/4PTR34MS	1/2X1/4PTR34MSS	315	315
1/2-14	3/8-19	22	13.5	39	48	1/2X3/8PTR34MS	1/2X3/8PTR34MSS	315	315
3/4-14	1/4-19	27	11.7	39	108	3/4X1/4PTR34MS	3/4X1/4PTR34MSS	280	280
3/4-14	3/8-19	27	18.0	39	127	3/4X3/8PTR34MS	3/4X3/8PTR34MSS	280	280
3/4-14	1/2-14	27	18.0	42	94	3/4X1/2PTR34MS	3/4X1/2PTR34MSS	280	280
1-11	3/8-19	36	24.0	40	185	1X3/8PTR34MS	1X3/8PTR34MSS	210	210
1-11	1/2-14	36	24.0	48	224	1X1/2PTR34MS	1X1/2PTR34MSS	210	210
1-11	3/4-14	36	24.0	49	186	1X3/4PTR34MS	1X3/4PTR34MSS	210	210

Order codes shown are part of our current manufacturing programme.

Imperial and metric parts may vary in hexagon dimensions.

$$\frac{\text{PN (bar)}}{10} = \text{PN (MPa)}$$

Do not create drawings from these dimensions, they are subject to change and ISO manufacturing allowances.

Adapters

FF33M Male nipple

Male BSPT thread (ISO 7)

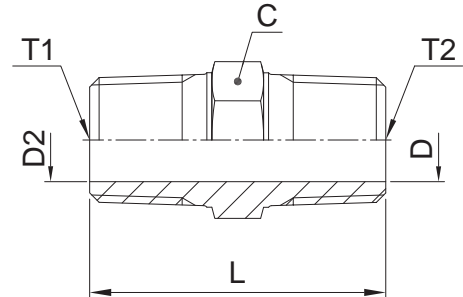

Thread BSPT T1	Thread BSPT T2	C mm	D mm	D2 mm	L mm	Weight (steel) g/1 piece	Adapter Steel	Adapter Stainless Steel	PN (bar)	
									S	SS
1/8-28	1/8-28	11	5.0	5.0	27	12	1/8FF33MS	1/8FF33MSS	315	315
1/4-19	1/8-28	14	5.0	5.0	32	25	1/4X1/8FF33MS	1/4X1/8FF33MSS	315	315
1/4-19	1/4-19	14	7.0	7.0	37	25	1/4FF33MS	1/4FF33MSS	315	315
3/8-19	1/4-19	17	7.0	7.0	37	42	3/8X1/4FF33MS	3/8X1/4FF33MSS	315	315
3/8-19	3/8-19	17	10.0	10.0	37	30	3/8FF33MS	3/8FF33MSS	315	315
1/2-14	1/4-19	22	7.0	7.0	43	68	1/2X1/4FF33MS	1/2X1/4FF33MSS	315	315
1/2-14	3/8-19	22	10.3	10.3	43	67	1/2X3/8FF33MS	1/2X3/8FF33MSS	315	315
1/2-14	1/2-14	22	13.5	13.5	48	72	1/2FF33MS	1/2FF33MSS	315	315
3/4-14	1/2-14	27	13.5	13.5	50	123	3/4X1/2FF33MS	3/4X1/2FF33MSS	160	160
3/4-14	3/4-14	27	18.0	18.0	50	110	3/4FF33MS	3/4FF33MSS	160	160
1-11	3/4-14	36	18.0	18.0	55	215	1X3/4FF33MS	1X3/4FF33MSS	160	160
1-11	1-11	36	23.8	23.8	59	190	1FF33MS	1FF33MSS	160	160

Order codes shown are part of our current manufacturing programme.

Imperial and metric parts may vary in hexagon dimensions.

$$\frac{\text{PN (bar)}}{10} = \text{PN (MPa)}$$

Do not create drawings from these dimensions, they are subject to change and ISO manufacturing allowances.

HP3M Hexagon head plug

Male BSPT thread (ISO 7)

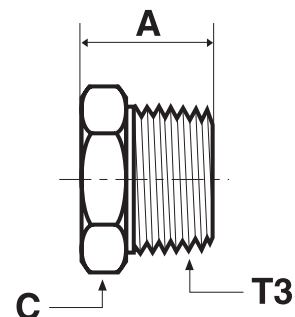

Thread BSPT T3	A mm	C mm	Weight (steel) g/1 piece	Adapter Steel	Adapter Stainless Steel	PN (bar)	
						S	SS
1/8-28	14	11	9	1/8HP3MS	1/8HP3MSS	315	315
1/4-19	19	14	16	1/4HP3MS	1/4HP3MSS	315	315
3/8-19	20	19	35	3/8HP3MS	3/8HP3MSS	315	315
1/2-14	25	22	52	1/2HP3MS	1/2HP3MSS	315	315
3/4-14	27	27	85	3/4HP3MS	3/4HP3MSS	160	160
1-11	32	36	134	1HP3MS	1HP3MSS	160	160

Order codes shown are part of our current manufacturing programme.

Imperial and metric parts may vary in hexagon dimensions.

$$\frac{\text{PN (bar)}}{10} = \text{PN (MPa)}$$

Do not create drawings from these dimensions, they are subject to change and ISO manufacturing allowances.

Adapters

0107 Swivel male stud

Male NPTF* thread (SAE J476) / NPSM Female swivel end (SAE J516)

SAE 140130

*Stainless Steel = NPT to prevent galling

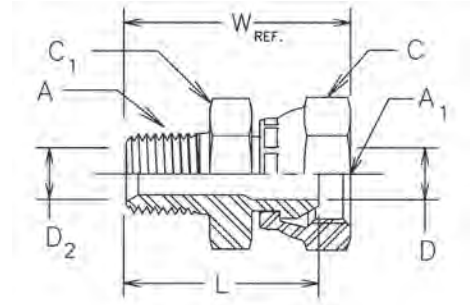

Thread NPTF A	Thread NPSM A1	C mm	C1 mm	D mm	D2 mm	L mm	W mm	Weight (steel) g/1 piece	Adapter Steel	Adapter Stainless Steel	PN (bar)	
											S	SS
1/8-27	1/8-27	14.3	14.3	4.0	4.8	24	28	23	0107-2-2	0107-2-2-SS	350	350
1/8-27	1/4-18	17.5	16.0	4.8	4.8	27	32	33	0107-2-4	0107-2-4-SS	350	350
1/4-18	1/4-18	17.5	17.5	5.6	7.1	32	36	40	0107-4-4	0107-4-4-SS	350	350
1/4-18	3/8-18	22.2	20.6	7.1	7.1	32	37	57	0107-4-6	0107-4-6-SS	280	280
1/4-18	1/2-14	25.4	23.8	11.9	7.1	37	44	91	0107-4-8	0107-4-8-SS	245	245
3/8-18	1/4-18	17.5	17.5	5.6	10.3	33	38	48	0107-6-4	0107-6-4-SS	350	350
3/8-18	3/8-18	22.2	22.2	8.7	10.3	33	38	62	0107-6-6	0107-6-6-SS	280	280
3/8-18	1/2-14	25.4	23.8	10.3	10.3	37	44	97	0107-6-8	0107-6-8-SS	245	245
1/2-14	3/8-18	22.2	22.2	8.7	13.5	38	43	76	0107-8-6	0107-8-6-SS	280	280
1/2-14	1/2-14	25.4	25.4	11.9	13.5	41	49	109	0107-8-8	0107-8-8-SS	245	245
1/2-14	3/4-14	31.8	31.8	13.5	13.5	43	52	167	0107-8-12	0107-8-12-SS	140	140
3/4-14	1/2-14	25.4	28.6	11.9	18.3	41	49	122	0107-12-8	0107-12-8-SS	245	245
3/4-14	3/4-14	31.8	31.8	16.3	18.3	43	52	154	0107-12-12	0107-12-12-SS	140	140
3/4-14	1-11.5	38.0	38.0	21.4	18.3	46	55	247	0107-12-16	0107-12-16-SS	120	120
1-11.5	3/4-14	31.8	35.0	16.3	23.8	49	58	217	0107-16-12	0107-16-12-SS	140	140
1-11.5	1-11.5	38.0	38.0	21.4	23.8	51	60	238	0107-16-16	0107-16-16-SS	120	120
1-11.5	1 1/4-11.5	47.6	44.5	29.0	23.8	51	61	298	0107-16-20	0107-16-20-SS	120	120
1 1/4-11.5	1-11.5	38.0	47.6	21.4	31.8	53	63	356	0107-20-16	0107-20-16-SS	120	120
1 1/4-11.5	1 1/4-11.5	47.6	47.6	29.0	31.8	53	63	390	0107-20-20	0107-20-20-SS	120	120
1 1/2-11.5	1 1/2-11.5	54.0	54.0	34.5	38.1	56	66	498	0107-24-24	0107-24-24-SS	85	85
2-11.5	2-11.5	66.7	66.7	46.1	49.2	60	71	749	0107-32-32	0107-32-32-SS	75	75

Order codes shown are part of our current manufacturing programme.

Imperial and metric parts may vary in hexagon dimensions.

$$\frac{PN \text{ (bar)}}{10} = PN \text{ (MPa)}$$

Do not create drawings from these dimensions, they are subject to change and ISO manufacturing allowances.

2107 Swivel male elbow

Male NPTF* thread (SAE J476) / NPSM Female swivel end (SAE J516)

SAE 140230

*Stainless Steel = NPT to prevent galling

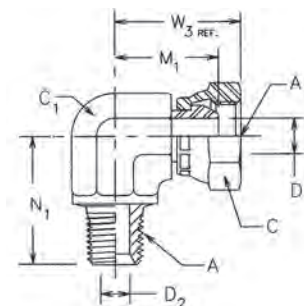

Thread NPTF A	Thread NPSM A1	C mm	C1 mm	D mm	D2 mm	M1 mm	N1 mm	W3 mm	Weight (steel) g/1 piece	Adapter Steel	Adapter Stainless Steel	PN (bar)	
												S	SS
1/8-27	1/8-27	14.3	11.0	4.0	4.8	18	18	22	28	2107-2-2	2107-2-2-SS	350	350
1/4-18	1/4-18	17.5	14.0	5.6	7.1	22	28	27	55	2107-4-4	2107-4-4-SS	350	350
1/4-18	3/8-18	22.2	19.0	8.7	7.1	25	28	33	94	2107-4-6	2107-4-6-SS	280	280
3/8-18	1/4-18	17.5	19.0	5.6	10.3	25	31	30	88	2107-6-4	2107-6-4-SS	350	350
3/8-18	3/8-18	22.2	19.0	8.7	10.3	25	31	33	90	2107-6-6	2107-6-6-SS	280	280
3/8-18	1/2-14	25.4	19.0	11.9	10.3	26	31	34	107	2107-6-8	2107-6-8-SS	245	245
1/2-14	3/8-18	22.2	22.0	8.7	13.5	27	37	34	130	2107-8-6	2107-8-6-SS	280	280
1/2-14	1/2-14	25.4	22.0	11.9	13.5	28	37	36	139	2107-8-8	2107-8-8-SS	245	245
1/2-14	3/4-14	31.8	27.0	16.3	13.5	33	37	42	221	2107-8-12	2107-8-12-SS	140	140
3/4-14	3/8-18	22.2	27.0	8.7	18.3	30	40	38	227	2107-12-6	2107-12-6-SS	280	280
3/4-14	1/2-14	25.4	27.0	11.9	18.3	32	40	39	191	2107-12-8	2107-12-8-SS	245	245
3/4-14	3/4-14	31.8	27.0	16.3	18.3	33	40	42	225	2107-12-12	2107-12-12-SS	140	140
1-11.5	3/4-14	31.8	33.3	16.3	23.8	37	50	46	374	2107-16-12	2107-16-12-SS	140	140
1-11.5	1-11.5	38.0	33.3	21.4	23.8	39	50	49	361	2107-16-16	2107-16-16-SS	120	120
1 1/4-11.5	1 1/4-11.5	47.6	41.0	29.0	31.8	44	61	54	794	2107-20-20	2107-20-20-SS	120	120
1 1/2-11.5	1 1/2-11.5	54.0	47.6	34.5	38.1	48	67	59	782	2107-24-24	2107-24-24-SS	85	85
2-11.5	2-11.5	66.7	63.5	46.1	49.2	58	76	69	1910	2107-32-32	2107-32-32-SS	75	75

Order codes shown are part of our current manufacturing programme.

Imperial and metric parts may vary in hexagon dimensions.

$$\frac{\text{PN (bar)}}{10} = \text{PN (MPa)}$$

Do not create drawings from these dimensions, they are subject to change and ISO manufacturing allowances.

Adapters

3107 Swivel male 45° elbow

Male NPTF* thread (SAE J476) / NPSM Female swivel end (SAE J516)
SAE 140330

*Stainless Steel = NPT to prevent galling

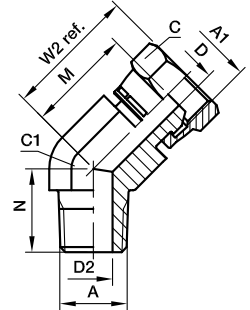

Thread NPTF A	Thread NPSM A1	C mm	C1 mm	D mm	D2 mm	M mm	N mm	W2 mm	Weight (steel) g/1 piece	Adapter Steel	Adapter Stainless Steel	PN (bar)	
												S	SS
1/8-27	1/8-27	14.3	11.0	4.0	4.8	16	13	20	21	3107-2-2		350	—
1/4-18	1/4-18	17.5	14.0	5.6	7.1	19	22	23	44	3107-4-4	3107-4-4-SS	350	350
3/8-18	3/8-18	22.2	19.0	8.7	10.3	21	24	28	80	3107-6-6	3107-6-6-SS	280	280
1/2-14	3/8-18	22.2	22.0	8.7	13.5	21	30	28	110	3107-8-6	3107-8-6-SS	280	280
1/2-14	1/2-14	25.4	22.0	11.9	13.5	22	30	30	114	3107-8-8	3107-8-8-SS	245	245
1/2-14	3/4-14	31.8	27.0	16.3	13.5	23	38	31	144	3107-8-12	3107-8-12-SS	140	140
3/4-14	1/2-14	25.4	27.0	11.9	18.3	24	31	31	153	3107-12-8	3107-12-8-SS	245	245
3/4-14	3/4-14	31.8	27.0	16.3	18.3	26	31	35	172	3107-12-12	3107-12-12-SS	140	140
1-11.5	3/4-14	31.8	33.3	16.3	23.8	28	38	37	245	3107-16-12	3107-16-12-SS	140	140
1-11.5	1-11.5	38.0	33.3	21.4	23.8	29	38	39	368	3107-16-16	3107-16-16-SS	120	120
1 1/4-11.5	1 1/4-11.5	47.6	41.0	29.0	31.8	31	42	41	619	3107-20-20	3107-20-20-SS	120	120
1 1/2-11.5	1 1/2-11.5	54.0	47.6	34.5	38.1	34	45	45	719	3107-24-24	3107-24-24-SS	85	85
2-11.5	2-11.5	66.7	63.5	46.1	49.2	37	54	48	1372	3107-32-32	3107-32-32-SS	75	75

Order codes shown are part of our current manufacturing programme.

Imperial and metric parts may vary in hexagon dimensions.

$$\frac{\text{PN (bar)}}{10} = \text{PN (MPa)}$$

Do not create drawings from these dimensions, they are subject to change and ISO manufacturing allowances.

0207 Female connector

Female NPTF* thread (SAE J476) / NPSM Female swivel end (SAE J516)

SAE 140131

*Stainless Steel = NPT to prevent galling

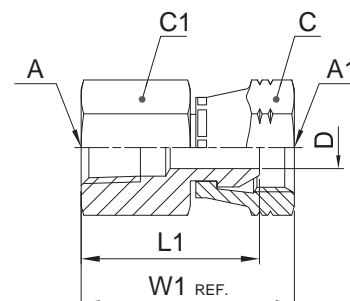

Thread NPTF A	Thread NPSM A1	C mm	C1 mm	D mm	L1 mm	W1 mm	Weight (steel) g/1 piece	Adapter Steel	Adapter Stainless Steel	PN (bar)	
										S	SS
1/8-27	1/8-27	14.3	14.3	4.0	22	26	15	0207-2-2	0207-2-2-SS	350	350
1/4-18	1/4-18	17.5	17.5	5.6	32	36	44	0207-4-4	0207-4-4-SS	350	350
3/8-18	1/4-18	17.5	22.2	5.6	33	38	52	0207-6-4	0207-6-4-SS	350	350
3/8-18	3/8-18	22.2	22.2	8.7	33	38	81	0207-6-6	0207-6-6-SS	280	280
1/2-14	3/8-18	22.2	25.4	8.7	39	44	121	0207-8-6	0207-8-6-SS	280	280
1/2-14	1/2-14	25.4	25.4	11.9	38	46	119	0207-8-8	0207-8-8-SS	245	245
3/4-14	3/4-14	31.8	31.8	16.3	41	50	161	0207-12-12	0207-12-12-SS	140	140
1-11.5	1-11.5	38.0	38.0	21.4	51	60	162	0207-16-16	0207-16-16-SS	120	120
1 1/4-11.5	1 1/4-11.5	47.6	47.6	29.0	51	61	378	0207-20-20	0207-20-20-SS	120	120
1 1/2-11.5	1 1/2-11.5	54.0	54.0	34.5	51	62	446	0207-24-24	0207-24-24-SS	85	85
2-11.5	2-11.5	66.7	66.7	46.1	54	65	707	0207-32-32	0207-32-32-SS	75	75

Order codes shown are part of our current manufacturing programme.

Imperial and metric parts may vary in hexagon dimensions.

$$\frac{\text{PN (bar)}}{10} = \text{PN (MPa)}$$

Do not create drawings from these dimensions, they are subject to change and ISO manufacturing allowances.

Adapters

2207 Female elbow

Female NPTF* thread (SAE J476) / NPSM Female swivel end (SAE J516)
SAE 140231

*Stainless Steel = NPT to prevent galling

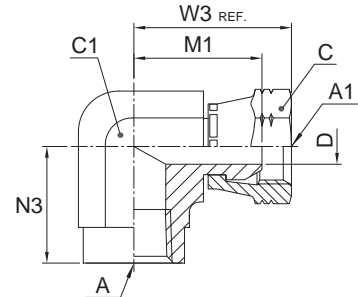

Thread NPTF A	Thread NPSM A1	C mm	C1 mm	D mm	M1 mm	W3 mm	N3 mm	Weight (steel) g/1 piece	Adapter Steel	Adapter Stainless Steel	PN (bar)	
											S	SS
1/8-27	1/8-27	14.3	14.0	4.0	20	24	17	37	2207-2-2	2207-2-2-SS	350	350
1/4-18	1/4-18	17.5	19.0	5.6	25	30	22	98	2207-4-4	2207-4-4-SS	350	350
3/8-18	3/8-18	22.2	22.0	8.7	27	32	26	152	2207-6-6	2207-6-6-SS	280	280
1/2-14	1/2-14	25.4	27.0	11.9	32	39	31	246	2207-8-8	2207-8-8-SS	245	245
3/4-14	3/4-14	31.8	33.3	16.3	37	46	35	313	2207-12-12	2207-12-12-SS	140	140
1-11.5	1-11.5	38.0	41.0	21.4	44	53	41	530	2207-16-16	2207-16-16-SS	120	120
1 1/4-11.5	1 1/4-11.5	47.6	47.6	29.0	47	56	43	1159	2207-20-20	2207-20-20-SS	120	120
1 1/2-11.5	1 1/2-11.5	54.0	63.5	34.5	61	72	53	1679	2207-24-24	2207-24-24-SS	85	85
2-11.5	2-11.5	66.7	71.5	46.1	65	76	61	2136	2207-32-32	2207-32-32-SS	75	75

Order codes shown are part of our current manufacturing programme.

Imperial and metric parts may vary in hexagon dimensions.

$$\frac{\text{PN (bar)}}{10} = \text{PN (MPa)}$$

Do not create drawings from these dimensions, they are subject to change and ISO manufacturing allowances.

0507 Swivel male stud

Male UN/UNF thread O-ring (ISO 11926) / NPSM Female swivel end (SAE J516)
SAE 140157

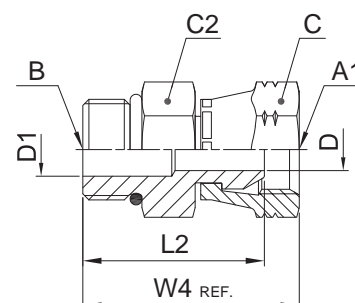

Thread UN/UNF-2A B	Thread NPSM A1	C mm	C2 mm	D mm	D1 mm	L2 mm	W4 mm	Weight (steel) g/1 piece	Adapter Steel	PN (bar)
7/16-20	1/4-18	17.5	14.3	5.6	5.6	29	34	32	0507-4-4	350
9/16-18	1/4-18	17.5	17.5	5.6	5.6	30	34	45	0507-6-4	350
9/16-18	3/8-18	22.2	17.5	8.7	8.7	30	35	48	0507-6-6	280
9/16-18	1/2-14	25.4	19.0	7.5	7.5	33	40	76	0507-6-8	245
3/4-16	1/4-18	17.5	22.2	5.6	9.9	32	36	65	0507-8-4	350
3/4-16	3/8-18	22.2	22.2	8.7	8.7	32	37	69	0507-8-6	280
3/4-16	1/2-14	25.4	22.2	9.9	9.9	32	40	83	0507-8-8	245
3/4-16	3/4-14	31.8	25.4	16.3	9.9	37	46	137	0507-8-12	140
7/8-14	1/2-14	25.4	25.4	11.9	11.9	37	44	98	0507-10-8	245
1 1/16-12	1/2-14	25.4	31.8	11.9	11.9	40	48	157	0507-12-8	245
1 1/16-12	3/4-14	31.8	31.8	16.3	16.3	41	50	200	0507-12-12	140
1 5/16-12	1-11.5	38.0	38.0	21.4	21.4	45	54	317	0507-16-16	120
1 5/8-12	1 1/4-11.5	47.6	47.6	27.4	27.4	47	56	398	0507-20-20	120
1 7/8-12	1 1/2-11.5	54.0	54.0	33.3	33.3	50	61	498	0507-24-24	85
2 1/2-12	2-11.5	66.7	70.0	45.2	45.2	52	63	749	0507-32-32	75

Parker Adapter are delivered with NBR elastomeric seals as standard. For more details on other seal materials see page O60.

Order codes shown are part of our current manufacturing programme.

Imperial and metric parts may vary in hexagon dimensions.

$$\frac{\text{PN (bar)}}{10} = \text{PN (MPa)}$$

Do not create drawings from these dimensions, they are subject to change and ISO manufacturing allowances.

Adapters

2507 Swivel male elbow

Male UN/UNF thread O-ring (ISO 11926) / NPSM Female swivel end (SAE J516)
SAE 140257

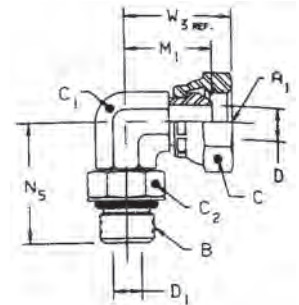

Thread UN/UNF-2A B	Thread NPSM A1	C mm	C1 mm	C2 mm	D mm	D1 mm	M1 mm	W3 mm	N5 mm	Weight (steel) g/1 piece	Adapter Steel	PN (bar)
7/16-20	1/4-18	17.5	11.0	14.3	5.6	4.4	20	25	26	42	2507-4-4	350
9/16-18	1/4-18	17.5	14.0	17.6	5.6	7.5	22	27	31	56	2507-6-4	350
9/16-18	3/8-18	22.2	14.0	17.6	8.7	7.5	22	28	31	56	2507-6-6	280
9/16-18	1/2-14	19.0	19.0	17.6	11.9	7.5	26	34	36	65	2507-6-8	245
3/4-16	3/8-18	22.2	19.0	22.2	8.7	9.9	25	30	37	119	2507-8-6	280
3/4-16	1/2-14	25.4	19.0	22.2	11.9	9.9	26	34	37	119	2507-8-8	245
3/4-16	3/4-14	31.8	27.0	22.2	16.0	9.9	33	42	41	174	2507-8-12	140
7/8-14	3/8-18	22.2	22.0	25.4	8.7	12.3	27	32	43	164	2507-10-6	280
7/8-14	1/2-14	25.4	22.0	25.4	11.9	12.3	28	36	43	178	2507-10-8	245
7/8-14	3/4-14	31.8	27.0	25.4	16.3	12.3	33	42	45	243	2507-10-12	140
1 1/16-12	1/2-14	25.4	27.0	31.8	11.9	15.5	31	38	49	193	2507-12-8	245
1 1/16-12	3/4-14	31.8	27.0	31.8	16.3	15.5	33	42	49	283	2507-12-12	140
1 5/16-12	1-11.5	38.0	33.3	38.0	21.4	21.4	39	49	53	525	2507-16-16	120
1 5/8-12	1 1/4-11.5	47.6	41.3	47.6	29.0	27.4	45	55	57	530	2507-20-20	120
1 7/8-12	1 1/2-11.5	54.0	47.6	54.0	34.5	33.3	48	59	61	600	2507-24-24	85

Parker Adapter are delivered with NBR elastomeric seals as standard. For more details on other seal materials see page O60.

Order codes shown are part of our current manufacturing programme.

Imperial and metric parts may vary in hexagon dimensions.

$$\frac{\text{PN (bar)}}{10} = \text{PN (MPa)}$$

Do not create drawings from these dimensions, they are subject to change and ISO manufacturing allowances.

3507 Swivel male 45° elbow

Male UN/UNF thread O-ring (ISO 11926) / NPSM Female swivel end (SAE J516)
SAE 140357

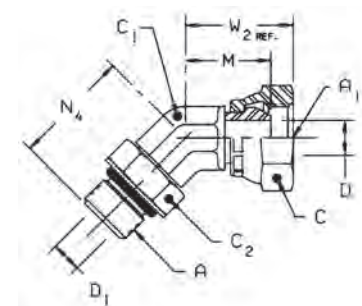

Thread UN/UNF-2A A	Thread NPSM A1	C mm	C1 mm	C2 mm	D mm	D1 mm	M mm	W2 mm	N4 mm	Weight (steel) g/1 piece	Adapter Steel	PN (bar)
7/16-20	1/4-18	17.5	11.0	14.3	5.6	4.4	16	20	27	41	3507-4-4	350
9/16-18	3/8-18	22.2	14.0	17.5	8.7	7.5	21	26	29	62	3507-6-6	280
3/4-16	3/8-18	22.2	19.0	22.2	8.7	9.9	21	26	33	106	3507-8-6	280
3/4-16	1/2-14	25.4	19.0	22.2	11.9	9.9	21	30	33	141	3507-8-8	245
3/4-16	3/4-14	31.8	27.0	22.2	16.3	9.9	26	35	36	226	3507-8-12	140
7/8-14	1/2-14	25.4	22.0	25.4	11.9	12.3	22	30	39	154	3507-10-8	245
1 1/16-12	3/4-14	31.8	27.0	31.8	16.3	15.5	26	35	44	208	3507-12-12	140
1 5/16-12	1-11.5	38.0	33.3	38.0	21.4	21.4	29	39	47	408	3507-16-16	120

Parker Adapter are delivered with NBR elastomeric seals as standard. For more details on other seal materials see page O60.

Order codes shown are part of our current manufacturing programme.

Imperial and metric parts may vary in hexagon dimensions.

$$\frac{\text{PN (bar)}}{10} = \text{PN (MPa)}$$

Do not create drawings from these dimensions, they are subject to change and ISO manufacturing allowances.

Adapters

F3T4 Male stud connector

JIS BSPP 60° cone adapters (JIS B8363) / Male BSPT thread (ISO 7)

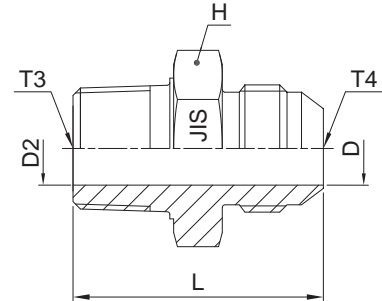

Thread BSPP T4	Thread BSPT T3	D mm	D2 mm	H mm	L mm	Weight (steel) g/1 piece	Adapter Steel	Adapter Stainless Steel	PN (bar)	
									S	SS
1/4-19	1/4-19	4.5	4.5	19.0	37	41	4F3T4S	4F3MT4SS	315	315
1/4-19	3/8-19	4.5	4.5	22.2	38	61	4-6F3T4S	4-6F3MT4SS	315	315
3/8-19	1/4-19	7.0	7.0	22.2	40	57	6-4F3T4S	6-4F3MT4SS	315	315
3/8-19	3/8-19	7.0	7.0	22.2	40	66	6F3T4S	6F3MT4SS	315	315
1/2-14	3/8-19	10.3	10.3	27.0	43	88	8-6F3T4S	8-6F3MT4SS	315	315
1/2-14	1/2-14	11.0	11.0	27.0	48	105	8F3T4S	8F3MT4SS	315	200
3/4-14	3/4-14	15.9	15.9	36.5	53	334	12F3T4S	12F3MT4SS	160	160
1-11	1-11	21.0	21.0	41.3	58	268	16F3T4S	16F3MT4SS	120	120

Order codes shown are part of our current manufacturing programme.

Imperial and metric parts may vary in hexagon dimensions.

$$\frac{\text{PN (bar)}}{10} = \text{PN (MPa)}$$

Do not create drawings from these dimensions, they are subject to change and ISO manufacturing allowances.

C3T4 Male elbow

JIS BSPP 60° cone adapters (JIS B8363) / Male BSPT thread (ISO 7)

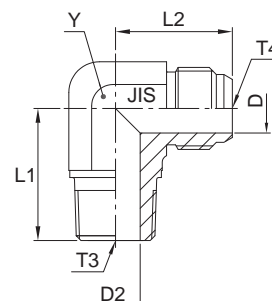

Thread BSPP T4	Thread BSPT T3	D mm	D2 mm	L1 mm	L2 mm	Y mm	Weight (steel) g/1 piece	Adapter Steel	PN (bar)
1/4-19	1/4-19	4.5	4.5	25	25	14.0	41	4C3T4S	315
3/8-19	3/8-19	7.0	7.0	30	29	19.0	74	6C3T4S	315
1/2-14	1/2-14	11.0	11.0	36	34	22.0	131	8C3T4S	200
3/4-14	3/4-14	15.9	15.9	43	38	27.0	146	12C3T4S	160
1-11	1-11	21.0	21.0	50	44	33.3	398	16C3T4S	120

Do not create drawings from these dimensions, they are subject to change and ISO manufacturing allowances.

V3T4 Male 45° elbow

JIS BSPP 30° Flare end (JIS B8363) / Male BSPT thread (ISO 7)

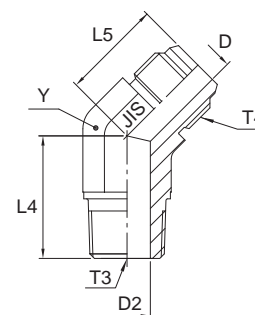

Thread BSPP T4	Thread BSPT T3	D mm	D2 mm	L4 mm	L5 mm	Y mm	Weight (steel) g/1 piece	Adapter Steel	PN (bar)
1/4-19	1/4-19	4.5	4.5	19	22	14.0	33	4V3T4S	315
3/8-19	3/8-19	7.0	7.0	22	25	19.0	64	6V3T4S	315
1/2-14	1/2-14	11.0	11.0	27	28	22.0	112	8V3T4S	200
3/4-14	3/4-14	15.9	15.9	30	32	27.0	162	12V3T4S	160
1-11	1-11	21.0	21.0	35	32	33.3	256	16V3T4S	120

Order codes shown are part of our current manufacturing programme.

Imperial and metric parts may vary in hexagon dimensions.

$$\frac{\text{PN (bar)}}{10} = \text{PN (MPa)}$$

Do not create drawings from these dimensions, they are subject to change and ISO manufacturing allowances.

Adapters

HP4 Union

JIS BSPP 60° cone end (JIS B8363)

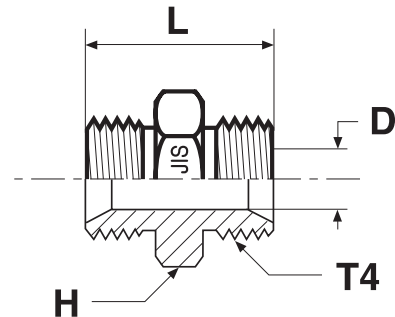

Thread BSPP T4	D mm	H mm	L mm	Weight (steel) g/1 piece	Adapter Steel	Adapter Stainless Steel	PN (bar)	
							S	SS
1/4-19	4.5	19.0	34	40	4HP4S	4HMP4SS	350	350
3/8-19	7.0	22.2	38	91	6HP4S	6HMP4SS	350	350
1/2-14	11.0	27.0	46	159	8HP4S	8HMP4SS	200	200
3/4-14	15.9	36.5	52	186	12HP4S	12HMP4SS	200	200
1-11	21.0	41.3	58	290	16HP4S	16HMP4SS	120	120

Do not create drawings from these dimensions, they are subject to change and ISO manufacturing allowances.

HP46 Swivel female union

JIS BSPP 60° Cone swivel female end (JIS B8363)

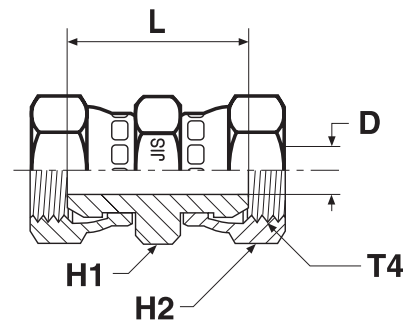

Thread BSPP T4	D mm	H1 mm	H2 mm	L mm	Weight (steel) g/1 piece	Adapter Steel	PN (bar)
3/8-19	7.0	22.2	22.2	35	49	6HP46S	350
1/2-14	11.0	27.0	27.0	38	77	8HP46S	200
3/4-14	15.9	36.5	36.5	40	114	12HP46S	200
1-11	21.0	41.3	41.3	46	180	16HP46S	120

Order codes shown are part of our current manufacturing programme.

Imperial and metric parts may vary in hexagon dimensions.

$$\frac{PN \text{ (bar)}}{10} = PN \text{ (MPa)}$$

Do not create drawings from these dimensions, they are subject to change and ISO manufacturing allowances.

F3P4 Male stud connector

JIS BSPP 60° Cone end (JIS B8363) / Male BSPT thread (ISO 7)

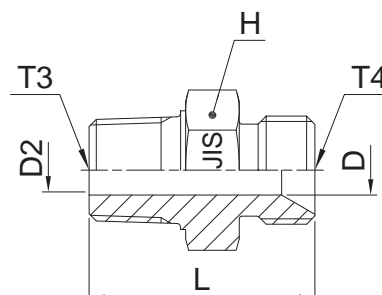

Thread BSPP T4	Thread BSPT T3	D mm	D2 mm	H mm	L mm	Weight (steel) g/1 piece	Adapter Steel	Adapter Stainless Steel	PN (bar)	
									S	SS
1/4-19	1/4-19	4.5	4.5	19.0	37	47	4F3P4S	4F3MP4SS	315	315
3/8-19	3/8-19	7.0	7.0	22.2	38	67	6F3P4S	6F3MP4SS	315	315
1/2-14	1/2-14	11.0	11.0	27.0	46	109	8F3P4S	8F3MP4SS	200	200
3/4-14	3/4-14	15.9	15.9	36.5	52	195	12F3P4S	12F3MP4SS	160	160
1-11	1-11	21.0	21.0	41.3	58	292	16F3P4S	16F3MP4SS	120	120

Do not create drawings from these dimensions, they are subject to change and ISO manufacturing allowances.

C3P4 Male 90° elbow

JIS BSPP 60° cone end (JIS B8363) / Male BSPT thread (ISO 7)

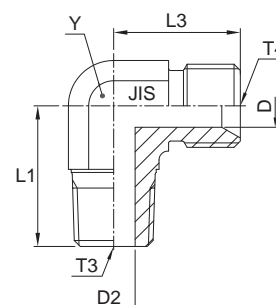

Thread BSPP T4	Thread BSPT T3	D mm	D2 mm	L1 mm	L3 mm	Y mm	Weight (steel) g/1 piece	Adapter Steel	PN (bar)
3/8-19	3/8-19	7.0	7.0	30	29	19.0	97	6C3P4S	315
1/2-14	1/2-14	11.0	11.0	36	33	22.0	147	8C3P4S	200
3/4-14	3/4-14	15.9	15.9	43	40	27.0	206	12C3P4S	160
1-11	1-11	21.0	21.0	50	44	33.3	434	16C3P4S	120

Order codes shown are part of our current manufacturing programme.

Imperial and metric parts may vary in hexagon dimensions.

$$\frac{\text{PN (bar)}}{10} = \text{PN (MPa)}$$

Do not create drawings from these dimensions, they are subject to change and ISO manufacturing allowances.

Adapters

V3P4 Male 45° elbow

JIS BSPP 60° Cone end (JIS B8363) / Male BSPT thread (ISO 7)

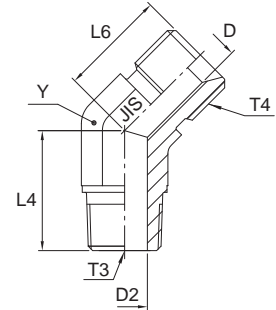

Thread BSPP T4	Thread BSPT T3	D mm	D2 mm	L4 mm	L6 mm	Y mm	Weight (steel) g/1 piece	Adapter Steel	PN (bar)
1/4-19	1/4-19	4.5	4.5	19	21	14.0	36	4V3P4S	350
3/8-19	3/8-19	7.0	7.0	22	23	19.0	65	6V3P4S	350
1/2-14	1/2-14	11.0	11.0	27	27	22.0	122	8V3P4S	200
3/4-14	3/4-14	15.9	15.9	30	30	27.0	159	12V3P4S	200
1-11	1-11	21.0	21.0	35	33	33.3	412	16V3P4S	120

Do not create drawings from these dimensions, they are subject to change and ISO manufacturing allowances.

F63P4 Swivel male stud

JIS BSPP 60° Cone swivel female end (JIS B8363) / Male BSPT thread (ISO 7)

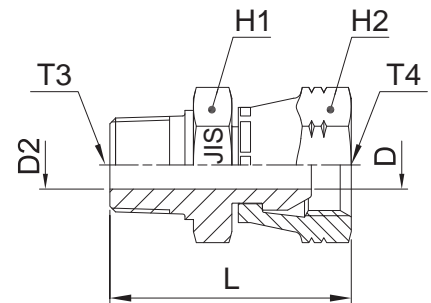

Thread BSPT T3	Thread BSPP T4	D mm	D2 mm	H1 mm	H2 mm	L mm	Weight (steel) g/1 piece	Adapter Steel	Adapter Stainless Steel	PN (bar)	
									S	SS	
1/4-19	1/4-19	4.5	4.5	19.0	19.0	33	41	4F63P4S	4F63MP4SS	315	315
3/8-19	3/8-19	7.0	7.0	22.2	22.2	37	70	6F63P4S	6F63MP4SS	315	315
1/2-14	1/2-14	11.0	11.0	27.0	27.0	42	122	8F63P4S	8F63MP4SS	200	200
3/4-14	3/4-14	15.9	15.9	36.5	36.5	47	254	12F63P4S	12F63MP4SS	160	160
1-11	1-11	21.0	21.0	41.3	41.3	52	367	16F63P4S	16F63MP4SS	120	120

Order codes shown are part of our current manufacturing programme.

Imperial and metric parts may vary in hexagon dimensions.

$$\frac{PN \text{ (bar)}}{10} = PN \text{ (MPa)}$$

Do not create drawings from these dimensions, they are subject to change and ISO manufacturing allowances.

G63P4 Female swivel connector

JIS BSPP 30° Flare swivel female end (JIS B8363) / Female BSPT thread (ISO 7)

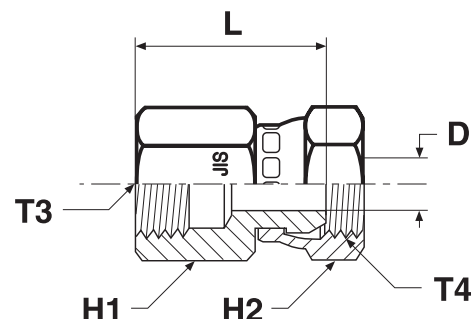

Thread BSPT T3	Thread BSPP T4	D mm	H1 mm	H2 mm	L mm	Weight (steel) g/1 piece	Adapter Steel	PN (bar)
1/4-19	1/4-19	4.5	19.0	19.0	30	36	4G63P4S	315
3/8-19	3/8-19	7.0	22.2	22.2	33	49	6G63P4S	315
1/2-14	1/2-14	11.0	27.0	27.0	36	73	8G63P4S	200
3/4-14	3/4-14	15.9	36.5	36.5	38	163	12G63P4S	160
1-11	1-11	21.0	41.3	41.3	46	195	16G63P4S	120

Do not create drawings from these dimensions, they are subject to change and ISO manufacturing allowances.

G3P4 Female stud connector

JIS BSPP 30° Flare end (JIS B8363) / Female BSPT thread (ISO 7)

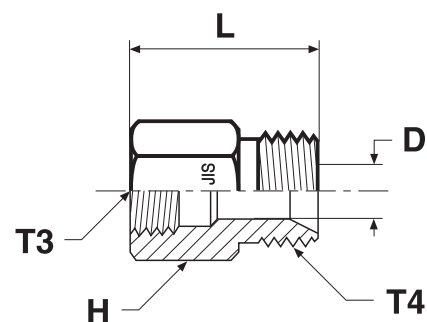

Thread BSPT T3	Thread BSPP T4	D mm	H mm	L mm	Weight (steel) g/1 piece	Adapter Steel	PN (bar)
1/4-19	1/4-19	4.5	19.0	31	40	4G3P4S	315
3/8-19	3/8-19	7.0	22.2	34	55	6G3P4S	315
1/2-14	1/2-14	11.0	27.0	40	141	8G3P4S	200
3/4-14	3/4-14	15.9	36.5	44	159	12G3P4S	160
1-11	1-11	21.0	41.3	49	225	16G3P4S	120

Order codes shown are part of our current manufacturing programme.

Imperial and metric parts may vary in hexagon dimensions.

$$\frac{\text{PN (bar)}}{10} = \text{PN (MPa)}$$

Do not create drawings from these dimensions, they are subject to change and ISO manufacturing allowances.

Adapters

Spare parts guide – Triple-Lok® retaining rings and seals

BSPP male threads – ISO 1179

BSPP Thread	ED seal Order code		O-ring order code*		O-ring ID x section mm	Retainer ring Order code Steel	Retainer ring Order code Stainless Steel
	NBR	FKM	NBR	FKM			
1/8	ED10X1X	ED10X1VITX	6-002-N552-9	6-002-V894-9	8.00 x 2.00	8207-1/8	8207SS1/8
1/4	ED14X1.5X	ED14X1.5VITX	2-111-N552-9	2-111-V894-9	10.77 x 2.62	8207-1/4	8207SS1/4A
3/8	ED3/8X	ED3/8VITX	2-113-N552-9	2-113-V894-9	13.94 x 2.62	8207-3/8	8207SS3/8A
1/2	ED1/2X	ED1/2VITX	5-256-N552-9	5-256-V894-9	17.96 x 2.62	8207-1/2	8207SS1/2
3/4	ED26X1.5X	ED26X1.5VITX	2-119-N552-9	2-119-V894-9	23.47 x 2.62	8207-3/4	8207SS3/4
1	ED33X2X	ED33X2VITX	2-217-N552-9	2-217-V894-9	29.74 x 3.53	8207-1	8207SS1A
1 1/4	ED42X2X	ED42X2VITX	2-222-N552-9	2-222-V894-9	37.69 x 3.53	8207-1-1/4	8207SS1 1/4
1 1/2	ED48X2X	ED48X2VITX	2-224-N552-9	2-224-V894-9	44.04 x 3.53	8207-1-1/2	8207SS1 1/2

Typical fittings using these parts: PTR44M / RI-ED / F4OHG5 etc.

* Must be used with correct retainer ring

Metric male threads – ISO 9974

Metric Thread	ED seal order code		O-ring Order code*		O-ring ID x section mm	Retainer ring Order code Steel	Retainer ring Order code Stainless Steel
	NBR	FKM	NBR	FKM			
M 10x1.0	ED10X1X	ED10X1VITX	6-074-N552-9	6-074-V894-9	8.00 x 1.50	M10RR	RRM10X1SS
M 12x1.5	ED12X1.5X	ED12x1.5VITX	2-012-N552-9	2-012-V894-9	9.25 x 1.78	M12RR	RRM12X1.5SS
M 14x1.5	ED14X1.5X	ED14X1.5VITX	2-013-N552-9	2-013-V894-9	10.82 x 1.78	M14RR	RRM14X1.5SS
M 16x1.5	ED16X1.5X	ED16X1.5VITX	3-907-N552-9	3-907-V894-9	13.46 x 2.08	M16RR	RRM16X1.5SS
M 18x1.5	ED18X1.5X	ED18X1.5VITX	2-114-N552-9	2-114-V894-9	15.54 x 2.62	M18RR	RRM18X1.5SS
M 22x2.0	ED22X1.5X	ED22X1.5VITX	2-018-N552-9	2-018-V894-9	18.77 x 1.78	M22RR	RRM22X1.5SS
M 27x2.0	ED26X1.5X**	ED26X1.5VITX	2-119-N552-9	2-119-V894-9	23.47 x 2.62	M27RR	RRM27X2SS
M 33x2.0	ED33X2X	ED33X2VITX	2-122-N552-9	2-122-V894-9	28.24 x 2.62	M33RR	RRM33X2SS
M 42x2.0	ED42X2X	ED42X2VITX	2-128-N552-9	2-128-V894-9	37.77 x 2.62	M42RR	RRM42X2SS
M 48x2.0	ED48X2X	ED48X2VITX	2-132-N552-9	2-132-V894-9	44.12 x 2.62	M48RR	RRM48X2SS

Typical fittings using these parts: F8OHG5 / VSTI MED etc.

* Must be used with correct retainer ring ** Same seal used for M 26x1.5 and M 27x2.0 Threads

UN / UNF male threads – ISO 11926

UN / UNF Thread	Dash size	O-ring Order code		O-Ring ID x section (mm)
		NBR	FKM	
5/16-24	2	3-902-N552-9	3-902-V894-9	6.07 x 1.63
3/8-24	3	3-903-N552-9	3-903-V894-9	7.65 x 1.63
7/16-20	4	3-904-N552-9	3-904-V894-9	8.92 x 1.83
1/2-20	5	3-905-N552-9	3-905-V894-9	10.52 x 1.83
9/16-18	6	3-906-N552-9	3-906-V894-9	11.89 x 1.98
3/4-16	8	3-908-N552-9	3-908-V894-9	16.36 x 2.21
7/8-14	10	3-910-N552-9	3-910-V894-9	19.18 x 2.46
1 1/16-12	12	3-912-N552-9	3-912-V894-9	23.47 x 2.95
1 3/16-12	14	3-914-N552-9	3-914-V894-9	26.59 x 2.95
1 5/16-12	16	3-916-N552-9	3-916-V894-9	29.74 x 2.95
1 5/8-12	20	3-920-N552-9	3-920-V894-9	37.47 x 3.00
1 7/8-12	24	3-924-N552-9	3-924-V894-9	43.69 x 3.00
2 1/2-12	32	3-932-N552-9	3-932-V894-9	59.36 x 3.00

Typical fittings using these parts: F5OG / P5ON / F5OHAO etc.

Metric male threads – ISO 6149

Metric Thread	O-ring Order code		O-Ring ID x section (mm)
	NBR	FKM	
M 10x1.0	6-345-N552-9	6-345-V894-9	8.20 x 1.50
M 12x1.5	6-346-N552-9	6-346-V894-9	9.40 x 2.10
M 14x1.5	6-347-N552-9	6-347-V894-9	11.40 x 2.10
M 16x1.5	6-348-N552-9	6-348-V894-9	13.40 x 2.10
M 18x1.5	6-349-N552-9	6-349-V894-9	15.40 x 2.10
M 22x1.5	6-350-N552-9	6-350-V894-9	19.40 x 2.10
M 27x2.0	6-351-N552-9	6-351-V894-9	23.70 x 2.80
M 33x2.0	6-352-N552-9	6-352-V894-9	29.70 x 2.80
M 42x2.0	6-353-N552-9	6-353-V894-9	38.70 x 2.80
M 48x2.0	6-354-N552-9	6-354-V894-9	46.70 x 2.80

Typical fittings using these parts: VSTI-OR etc.

BSPP Bonded Seal

BSPP Thread Size	O.D. (mm)	I.D. (mm)	W (mm)	Material			Order code
				S*	SS	B	
1/8-28	15.9	10.4	2.0	•			D9DT-2
1/4-19	20.6	13.7	2.0	•			D9DT-4
3/8-19	23.8	17.3	2.0	•			D9DT-6
1/2-14	28.6	21.5	2.3	•			D9DT-8
5/8-14	31.8	23.5	2.3	•			D9DT-10
3/4-14	34.9	27.1	2.3	•			D9DT-12
1-11	42.8	33.9	2.3	•			D9DT-16
1 1/4-11	52.4	42.9	3.3	•			D9DT-20
1 1/2-11	58.6	48.4	3.3	•			D9DT-24

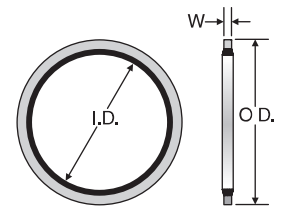

Used on K4 Style Straight Fittings as a Port Seal. For use with ISO 1179 / DIN 3852-2 port.

* NBR is the standard elastomer compound - 90-durometer Nitrile Zinc plated steel ring

Other seal compounds available on request for alternative applications



EO[®] Ermeto Original Valves



Visual index Non return valves

RHD / p. P13

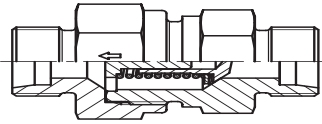

EO 24° cone end / EO 24° cone end

RHV-R-ED / p. P14

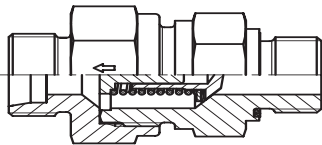

EO 24° cone end /
Male BSPP thread – ED-seal (ISO 1179)

RHZ-R-ED / p. P15

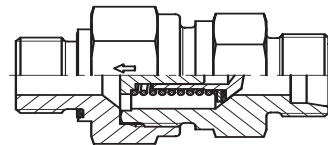

Male BSPP thread – ED-seal (ISO 1179) /
EO 24° cone end

RHV-M-ED / p. P16

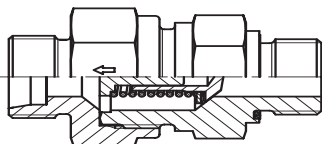

EO 24° cone end /
Male metric thread – ED-seal (ISO 9974)

RHZ-M-ED / p. P17

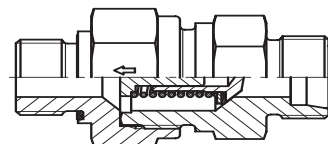

Male metric thread – ED-seal (ISO 9974) /
EO 24° cone end

RHDI / p. P18

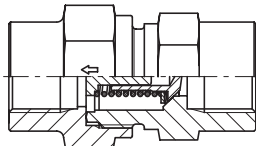

Female BSPP thread (ISO 1179-1) /
Female BSPP thread (ISO 1179-1)

RVP / p. P19

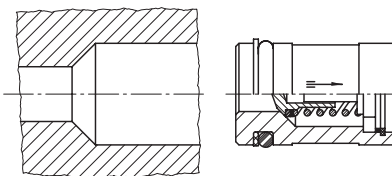

Non return valve cartridge

I-TL / p. P20

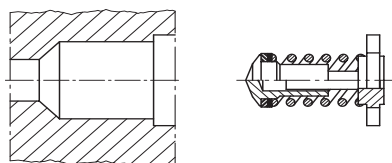

Internal parts of non return valve

Visual index Non return valves with O-Lok® connections

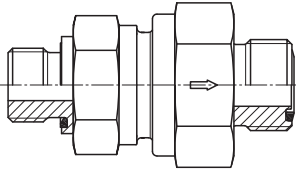
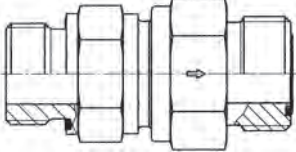
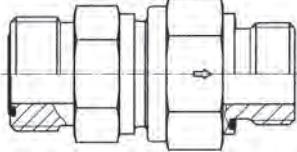
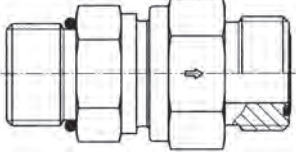
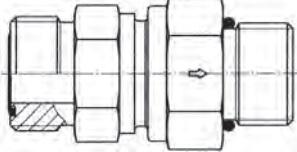
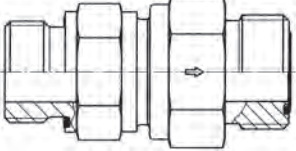
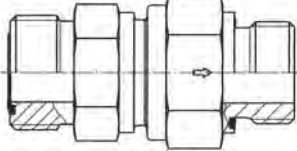
<p>RHDMLOS / p. P22</p>  <p>O-Lok® ORFS end / O-Lok® ORFS end</p>	
<p>RHV42EDMLOS / p. P23</p>  <p>Male BSPP thread – ED-seal (ISO 1179) / O-Lok® ORFS end</p>	<p>RHZ42EDMLOS / p. P24</p>  <p>O-Lok® ORFS end / Male BSPP thread – ED-seal (ISO 1179)</p>
<p>RHV50MLOS / p. P25</p>  <p>Male UN/UNF thread– O-ring (ISO 11926) / O-Lok® ORFS end</p>	<p>RHZ50MLOS / p. P26</p>  <p>O-Lok® ORFS end / Male UN/UNF thread– O-ring (ISO 11926)</p>
<p>RHV82EDMLOS / p. P27</p>  <p>Male metric thread – ED-seal (ISO 9974) / O-Lok® ORFS end</p>	<p>RHZ82EDMLOS / p. P28</p>  <p>O-Lok® ORFS end / Male metric thread – ED-seal (ISO 9974)</p>

Visual index Non return valves with Triple-Lok® connections

RHDMTXS / p. P29

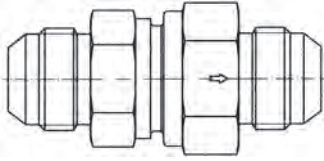

Triple-Lok® 37° flare end /
Triple-Lok® 37° flare end

RHV42EDMXS / p. P30

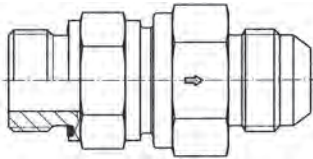

Male BSPP thread – ED-seal (ISO 1179) /
Triple-Lok® 37° flare end

RHZ42EDMXS / p. P31

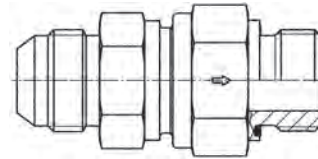

Triple-Lok® 37° flare end /
Male BSPP thread – ED-seal (ISO 1179)

RHV50MXS / p. P32

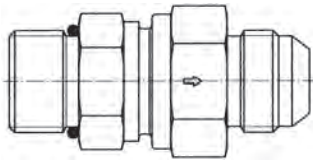

Male UN/UNF thread – O-ring (ISO 11926) /
Triple-Lok® 37° flare end

RHZ50MXS / p. P33

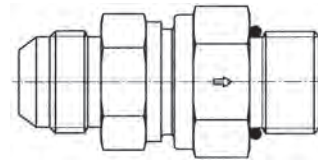

Triple-Lok® 37° flare end /
Male UN/UNF thread – O-ring (ISO 11926)

RHV82EDMXS / p. P34

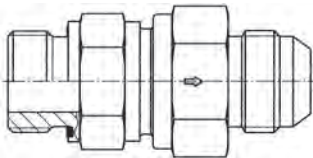

Male metric thread – ED-seal (ISO 9974) /
Triple-Lok® 37° flare end

RHZ82EDMXS / p. P35

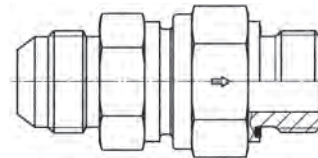

Triple-Lok® 37° flare end /
Male metric thread – ED-seal (ISO 9974)

Visual index 2-way ball valves

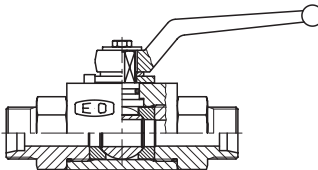
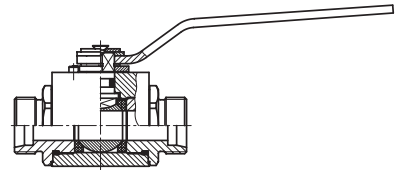
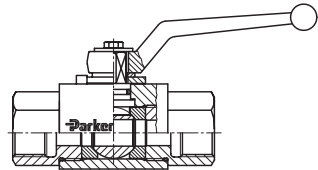
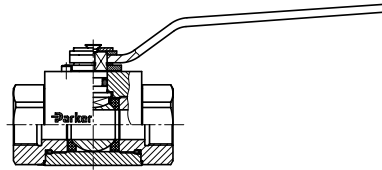
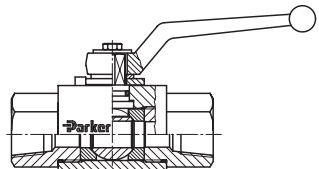
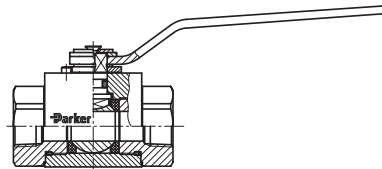
 <p>KH (Steel CF) p. P40</p> <p>EO 24° cone end</p>	 <p>KH (Stainless steel 71) p. P41</p> <p>EO 24° cone end</p>
 <p>KH-BSPP (Steel CF) p. P42</p> <p>Female BSPP thread (ISO 1179-1)</p>	 <p>KH-BSPP (Stainless steel 71) p. P43</p> <p>Female BSPP thread (ISO 1179-1)</p>
 <p>KH-NPT (Steel CF) p. P44</p> <p>Female NPT thread (SAE 476)</p>	 <p>KH-NPT (Stainless steel 71) p. P45</p> <p>Female NPT thread (SAE 476)</p>

Visual index 3-way ball valves

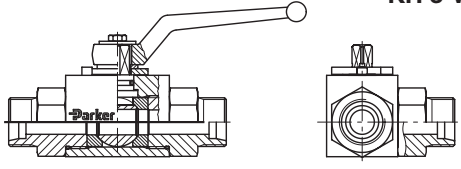
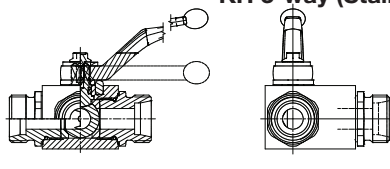
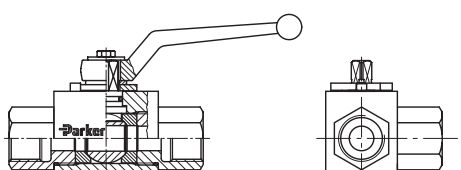
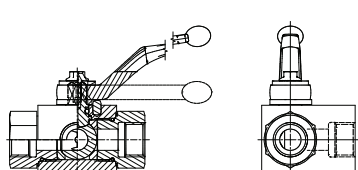
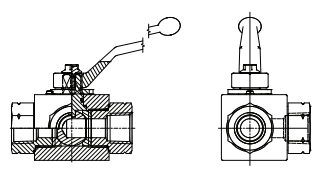
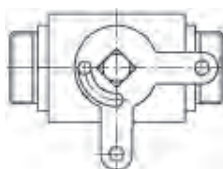
 <p>KH 3-way (Steel CF) p. P46</p> <p>EO 24° cone end</p>	 <p>KH 3-way (Stainless steel 71) p. P47</p> <p>EO 24° cone end</p>
 <p>KH 3-way BSPP (Steel CF) p. P48</p> <p>Female BSPP thread (ISO 1179-1)</p>	 <p>KH 3-way BSPP (Stainless steel 71) p. P49</p> <p>Female BSPP thread (ISO 1179-1)</p>
 <p>KH 3-way NPT (Steel CF) p. P50</p> <p>Female NPT thread (SAE 476)</p>	 <p>KHLOCKING p. P51</p> <p>Locking Devices for Two-Way and Multiway ball valves</p>

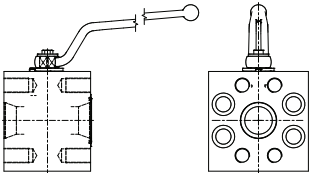
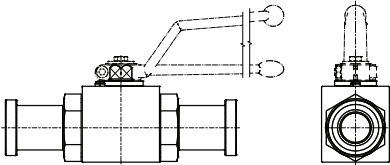
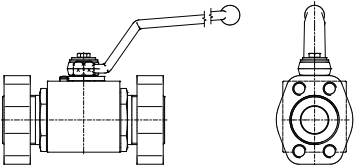

Visual index SAE ball valves

<p style="text-align: right;">KH-B1V (Steel CF) p. P52</p>  <p style="text-align: center;">Ball valve with SAE Flange connection</p>	<p style="text-align: right;">KH-A (Steel CF) p. P53</p>  <p style="text-align: center;">Ball valve with SAE Flange connection</p>
<p style="text-align: right;">KH-T (Steel CF) p. P54</p>  <p style="text-align: center;">Ball valve with SAE Flange connection ISO 6162 (1/2)</p>	<p style="text-align: center;">More flange ball valves see catalogue 4162</p>

Visual index ball valves for block structure

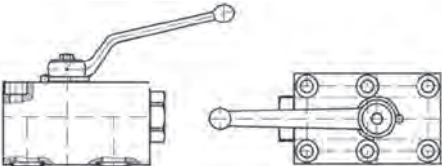
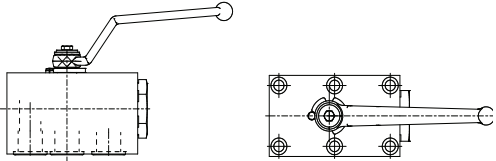
<p style="text-align: right;">KHBLOCK p. P55</p>  <p style="text-align: center;">2-way ball valve for block structure</p>	<p style="text-align: right;">KHBLOCK -3-way p. P56</p>  <p style="text-align: center;">3-way ball valve for block structure</p>
--	--

Visual index Flow Control Valves

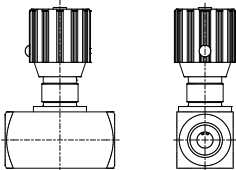
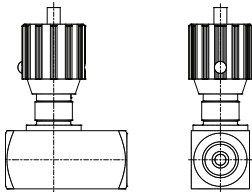
<p style="text-align: right;">RDV p. P58</p>  <p style="text-align: center;">Flow Control Valve (Female BSPP thread ISO 1179-1)</p>	<p style="text-align: right;">RDVR p. P59</p>  <p style="text-align: center;">Flow Control Check Valve (Female BSPP thread ISO 1179-1)</p>
---	--

Visual index shut off valves

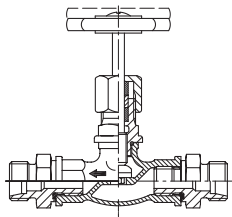

DV
p. P60

EO 24° cone end

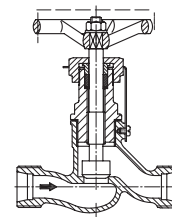

LD
p. P61

EO 24° cone end

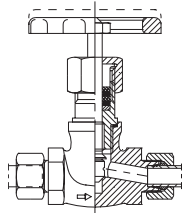

VDHA
p. P62

EO tube end

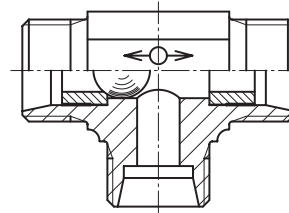

WV
p. P63

EO 24° cone end

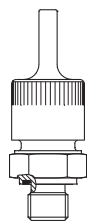

ELA/ELAE
p. P64/P65

Air-bleed valves

Range of non return valves, alternating valves and hand-operated shut off valves

Non-return valves with nominal pressure ratings up to PN 420 bar:

- with tube connection both ends: RHD
- with tube connection to male stud: RHV/RHZ
- with female thread both ends: RHDl
- valve cartridges: RVP
- valve internal parts: I-TL
- leakage rate hydraulic testing under test pressure: 1 drop per minute

Alternating valves:

- for nominal pressure ratings up to PN 160 WV
- leakage rate hydraulic testing under test pressure: 20 drops per minute

Shut-off valves:

- for high pressure ratings up to PN 630 bar VDHA

Design:

1. For materials, permissible working pressures, temperatures, flow medium torques for male studs etc. see relevant pages of the catalogue.
2. Tube connection ends must be assembled according to the Parker EO/EO-2 assembly instructions.
3. The valve bodies must be held rigidly during assembly of the tube connection ends.
4. Test pressures for non return valves: PN in conformance with O.D. information see chapter C.
5. Pressure drop values please see p. C12 and diagrams.

Caution!

Please note the admissible pressure ratings for the EO-tube ends.

Notes:

To assess the suitability of valves for specific applications, please advise us of the exact specification of the medium to be used, max. working pressure incl. pressure peaks, temperature and frequency of valve operations. If water is used, indicate type of water or additives, if any.

RHD/V/Z non return valve

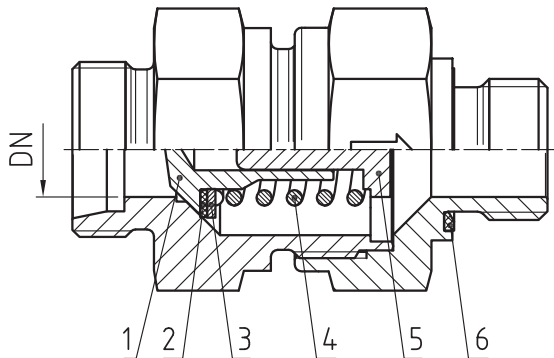

Design with sealing edge:
Size 06L and 08L / 06S and 08S
and all sizes in stainless steel with a PTFDE sealing disc.

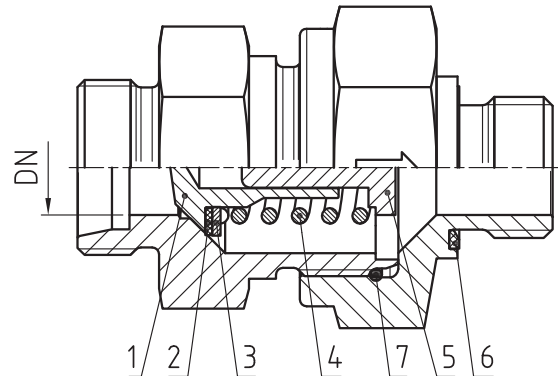

Design with O-ring (item. 7):
Sizes 10L, 12L, 15L, 18L, 22L, 28L, 35L and 42L
as well as 10S, 12S, 14S, 16S, 20S, 25S, 30S and 38S with a
sealing disc out of NBR (steel) or FKM (stainless steel).

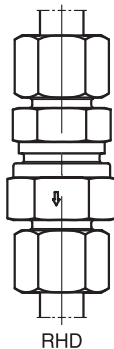

RHD



RHV

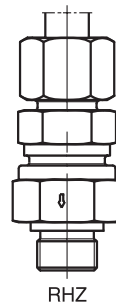

RHZ

- 1: poppet
 - 2: sealing disc
 - 3: cover disc
 - 4: spring
 - 5: passage disc
 - 6: Eolastic-sealing
 - 7: O-ring
- DN = Nominal diameter (mm)

Characteristics:

Poppet check valve with a 90° valve seat with an elastomere sealing disc. Poppet stop for controlled valve opening. Damped opening action to minimize shock and noise. No reduction of cross section. Maximum flow velocity not more than 8 m/sec. Sealing of male stud thread by Eolastic soft seal with types RHV and RHZ.

Opening pressure:

Standard 1 bar (on request also 0.2, 0.5, 2, 3, 4, 5 and 6 bar are available; please specify on order). For working pressure see appropriate tables. Cracking pressure tolerance: $\pm 20\%$.

Material:

- Steel zinc-plated (CF Cr[VI]-free), seals in NBR (e.g. Perbunan), or (FKM) on request.

Perbunan = registered trademark of Bayer

- Stainless steel valves have FKM as standard. (Up to 3 bar cracking pressure)

- Brass-valves (CuZn35Ni2 2.0540) with internals (1.4571) available on request. (Up to 3 bar cracking pressure)

Assembly:

See assembly instructions for EO/EO 2 connections. Non-return valves are all packaged against contamination.

Media:

Hydraulic oil, low flammability hydraulic fluids (except for types HFC: for HFD types; FKM seals are necessary). Air pressure tested (please indicate on order). Not suitable for steam, combustible/explosive gases, or oxygen. For water applications, please consult Parker with details of water and any additives.

In all diagrams is the peak value of the flow rate in l/min. relating to the maximum permissible flow velocity of 8 m/sec.

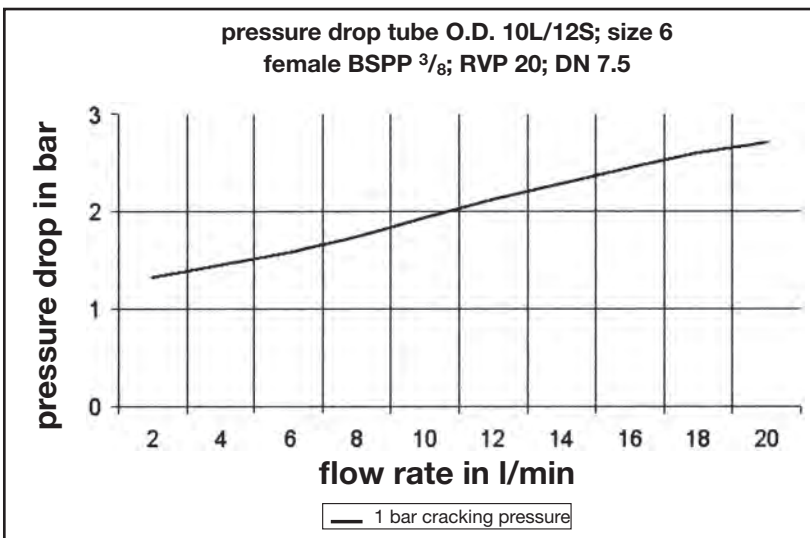
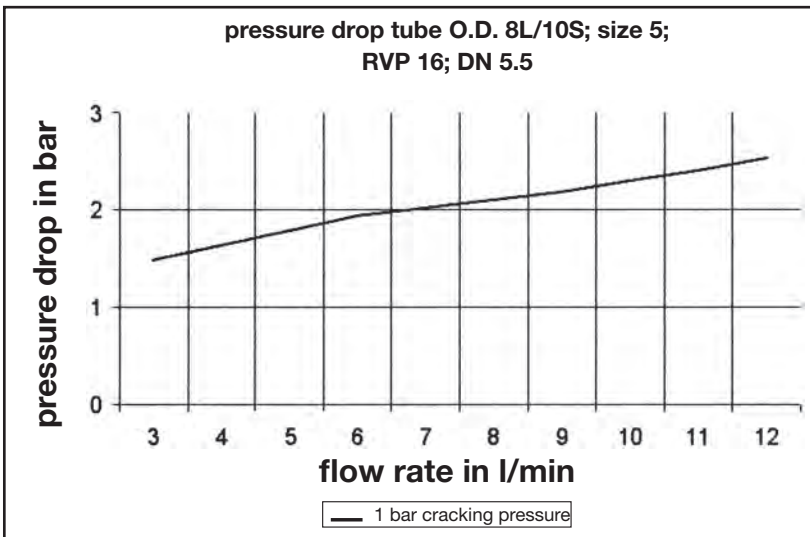
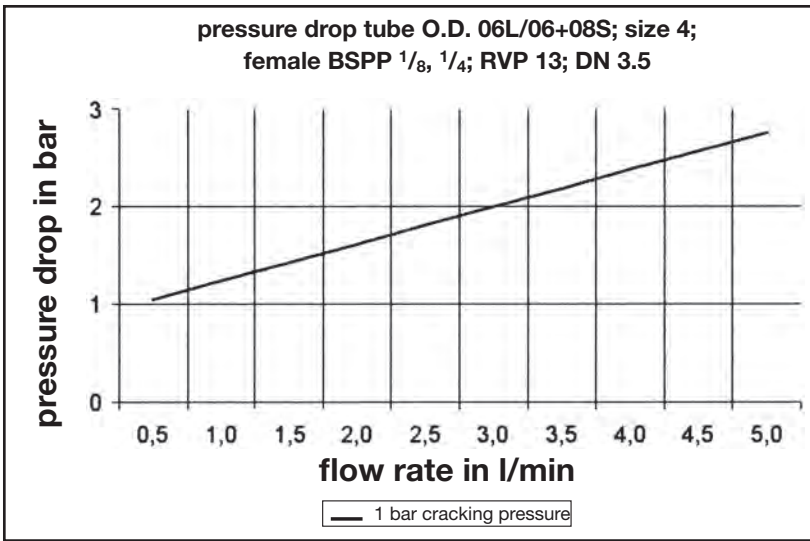

In all diagrams is the peak value of the flow rate in l/min. relating to the maximum permissible flow velocity of 8 m/sec.

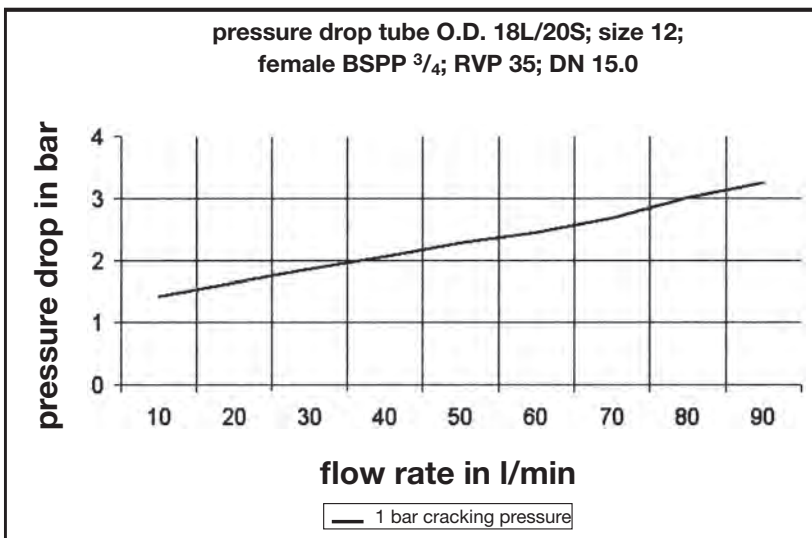
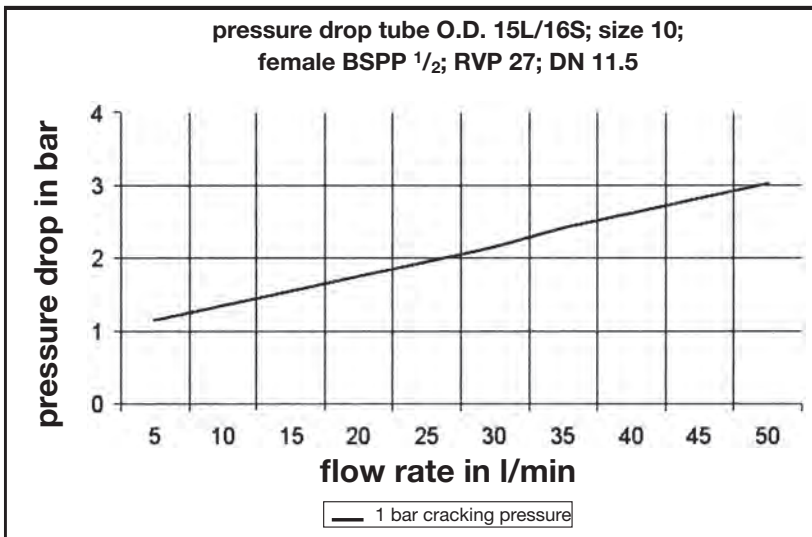
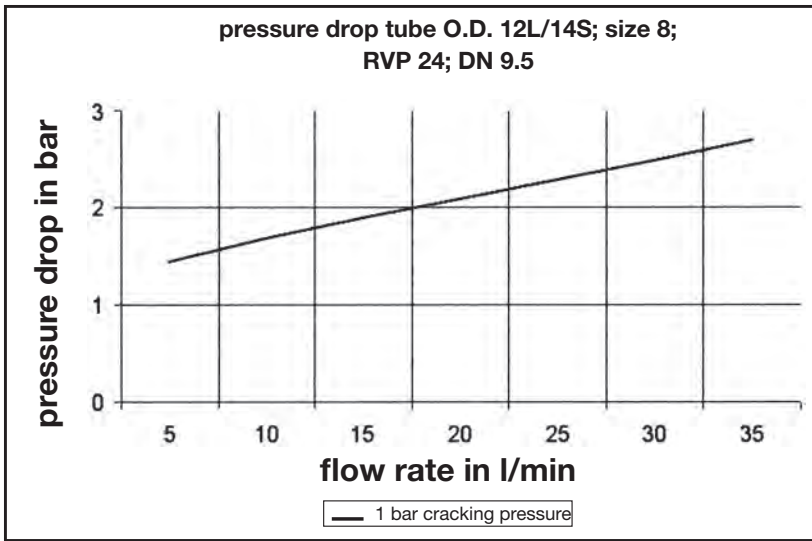

In all diagrams is the peak value of the flow rate in l/min. relating to the maximum permissible flow velocity of 8 m/sec.

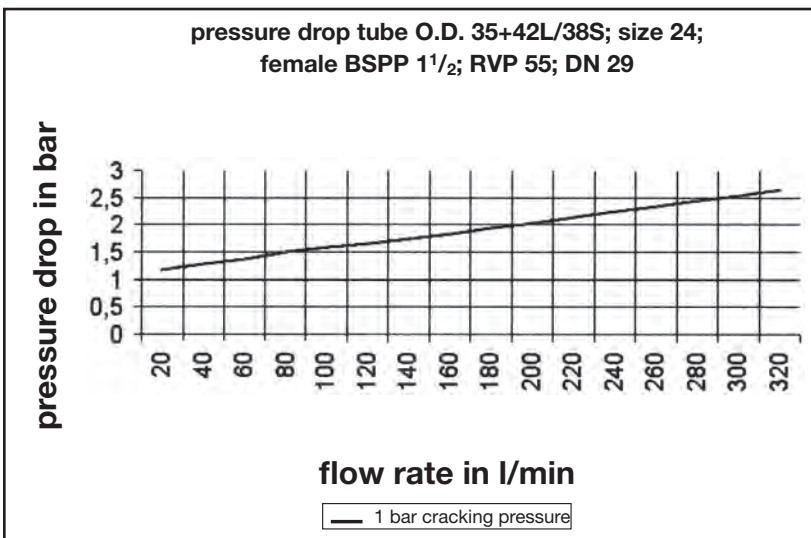
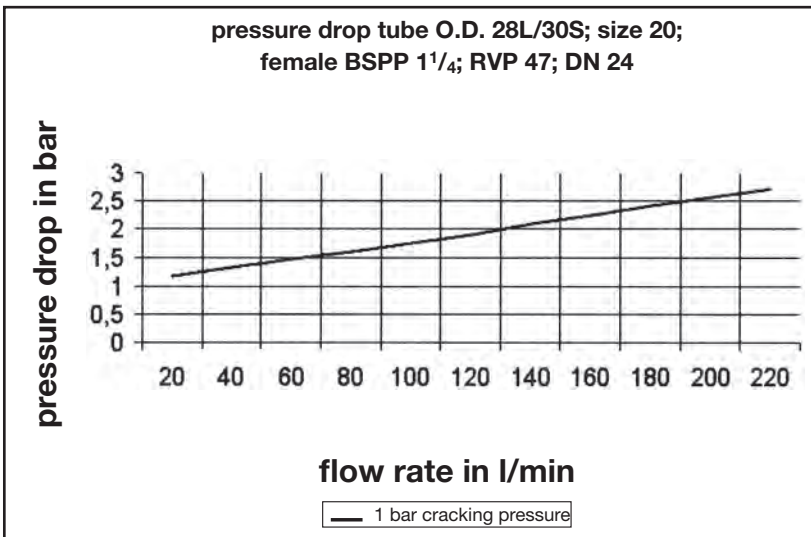
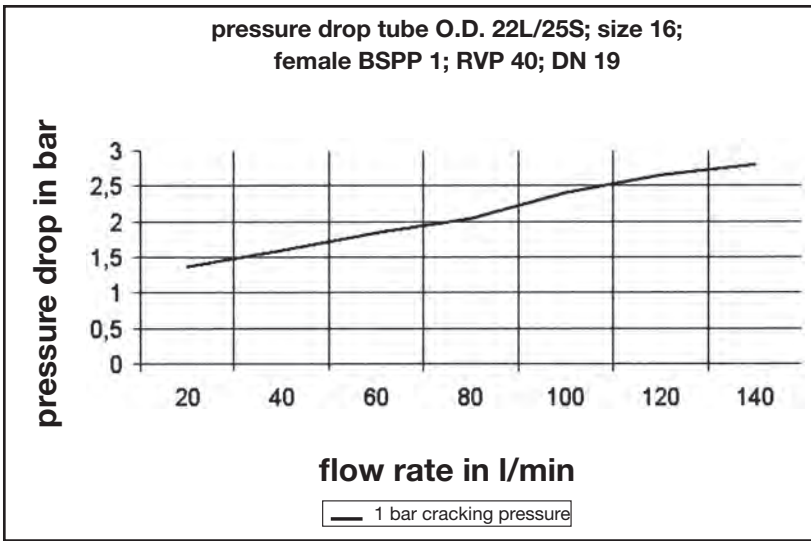

RHD Non return valve

EO 24° cone end / EO 24° cone end

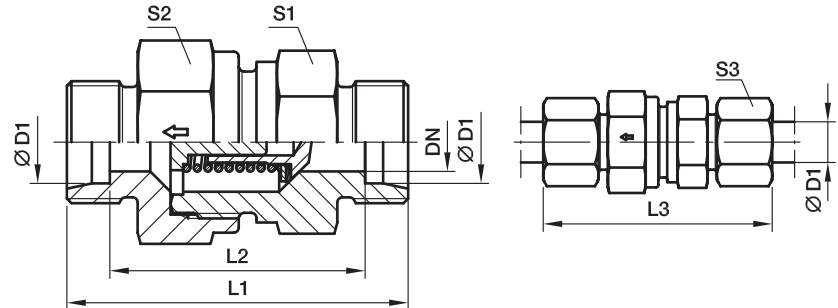

Series	D1 	CF DN	71 DN	L1	L2	L3	S1	CF S2	71 S2	S3	Weight g/1 piece	Order code*	PN (bar) ¹⁾	
													CF	71
L ³⁾	06	3.5	3.5	43.0	29.0	58.0	17	17	17	14	46	RHD06LOMD	400	250
	08	5.5	5.5	44.0	30.0	59.0	19	19	19	17	61	RHD08LOMD	400	250
	10	7.5	7.5	55.0	40.5	69.5	22	24	24	19	104	RHD10LOMD	400	250
	12	9.5	9.5	58.0	43.5	72.5	27	30	30	22	166	RHD12LOMD	400	250
	15	11.0	11.5	62.0	47.5	77.5	27	32	32	27	192	RHD15LOMD	400	250
	18	14.0	14.0	67.0	51.5	83.5	36	41	36	32	292	RHD18LOMD	400	160
	22	18.0	18.0	77.0	61.5	93.5	41	46	46	36	472	RHD22LOMD	250	160
	28	23.0	23.0	85.0	69.5	102.5	50	55	55	41	746	RHD28LOMD	250	100
	35	29.0	29.0	96.0	74.0	117.5	60	65	60	50	1062	RHD35LOMD	250	100
	42	29.0	29.0	96.0	74.0	119.0	65	70	70	60	1518	RHD42LOMD	250	100
S ⁴⁾	06	3.5	3.5	48.5	34.5	63.5	19	19	19	17	70	RHD06SOMD	420	400
	08	3.5	3.5	48.5	34.5	63.5	19	19	19	19	74	RHD08SOMD	420	400
	10	5.5	5.5	55.5	40.5	72.5	22	24	24	22	121	RHD10SOMD	420	400
	12	7.5	7.5	57.5	42.5	74.5	24	27	27	24	148	RHD12SOMD	420	400
	16	11.0	11.5	68.0	50.5	86.5	32	36	36	30	286	RHD16SOMD	420	315
	20	15.0	15.0	76.0	54.5	97.5	41	50	46	36	506	RHD20SOMD	420	250
	25	19.0	19.0	83.0	58.5	106.5	46	55	50	46	639	RHD25SOMD	420	250
	30	24.0	24.0	97.0	69.5	122.5	60	60	60	50	1157	RHD30SOMD	250	250
	38	29.0	29.0	108.0	75.5	136.5	65	70	70	60	1650	RHD38SOMD	250	250

¹⁾ Pressure shown = item deliverable

³⁾ L = light series; ⁴⁾ S = heavy series

$$\frac{\text{PN (bar)}}{10} = \text{PN (MPa)}$$

Delivery without nut and ring. Information on ordering complete fittings or alternative sealing materials see page 17.

*Please add the **suffixes** below according to the material/surface required.

Order code suffixes			
Material	Suffix surface and material	Example	Standard sealing material (no additional suffix needed)
Steel, zinc plated, Cr(VI)-free	CF	RHD06LOMDCF	NBR
Stainless steel	71	RHD06LOMD71	VIT

RHV-R-ED Non return valve

EO 24° cone end / Male BSPP thread – ED-seal (ISO 1179)

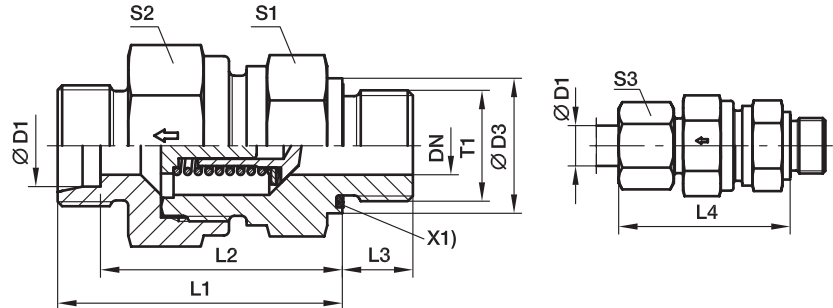

X1) Elastomeric sealing

Series	D1	T1	CF DN	71 DN	D3	L1	L2	L3	L4	S1	CF S2	71 S2	S3	Weight g/1 piece	Order code*	PN (bar) ¹⁾	
																CF	71
L ³⁾	06	G 1/8 A	3.5	3.5	14	35.0	28.0	8	42.5	17	17	17	14	47	RHV06LREDOMD	400	250
	08	G 1/4 A	5.5	5.5	19	37.0	30.0	12	44.5	19	19	19	17	62	RHV08LREDOMD	400	250
	10	G 1/4 A	7.5	7.5	19	46.0	38.5	12	53.0	22	24	24	19	105	RHV10LREDOMD	400	250
	12	G 3/8 A	9.5	9.5	22	50.0	42.5	12	57.0	27	30	30	22	175	RHV12LREDOMD	400	250
	15	G 1/2 A	11.0	11.5	27	53.0	45.5	14	60.5	27	32	32	27	205	RHV15LREDOMD	400	250
	18	G 1/2 A	14.0	14.0	27	58.0	50.0	14	66.0	36	41	36	32	294	RHV18LREDOMD	400	160
	22	G 3/4 A	18.0	18.0	32	63.0	55.0	16	71.0	41	46	46	36	450	RHV22LREDOMD	250	160
	28	G 1 A	23.0	23.0	40	71.0	63.0	18	79.5	50	55	55	41	720	RHV28LREDOMD	250	100
	35	G 1 1/4 A	29.0	29.0	50	80.0	69.0	20	90.5	60	65	65	50	1050	RHV35LREDOMD	250	100
	42	G 1 1/2 A	29.0	29.0	55	80.0	68.5	22	91.0	65	70	70	60	1560	RHV42LREDOMD	250	100
S ⁴⁾	06	G 1/4 A	3.5	3.5	19	38.5	31.5	12	46.0	19	19	19	17	73	RHV06SREDOMD	420	400
	08	G 1/4 A	3.5	3.5	19	38.5	31.5	12	46.0	19	19	19	19	79	RHV08SREDOMD	420	400
	10	G 3/8 A	5.5	5.5	22	45.5	38.0	12	54.0	22	24	24	22	132	RHV10SREDOMD	420	400
	12	G 3/8 A	7.5	7.5	22	48.5	41.0	12	57.0	24	27	27	24	153	RHV12SREDOMD	420	400
	16	G 1/2 A	11.0	11.5	27	57.0	48.0	14	66.0	32	36	36	30	293	RHV16SREDOMD	420	315
	20	G 3/4 A	15.0	15.0	32	63.0	52.0	16	73.5	41	50	46	36	511	RHV20SREDOMD	420	250
	25	G 1 A	19.0	19.0	40	67.0	54.5	18	78.5	46	55	50	46	648	RHV25SREDOMD	420	250
	30	G 1 1/4 A	24.0	24.0	50	78.0	64.0	20	90.5	60	60	60	50	1176	RHV30SREDOMD	250	250
38	G 1 1/2 A	29.0	29.0	55	86.0	69.5	22	100.0	65	70	70	60	1624	RHV38SREDOMD	250	250	

¹⁾Pressure shown = item deliverable

³⁾L = light series; ⁴⁾S = heavy series

$$\frac{PN \text{ (bar)}}{10} = PN \text{ (MPa)}$$

Delivery without nut and ring. Information on ordering complete fittings or alternative sealing materials see page 17.

*Please add the suffixes below according to the material/surface required.

Order code suffixes			
Material	Suffix surface and material	Example	Standard sealing material (no additional suffix needed)
Steel, zinc plated, Cr(VI)-free	CF	RHV06LREDOMDCF	NBR
Stainless steel	71	RHV06LREDOMD71	VIT

RHZ-R-ED Non return valve

Male BSPP thread – ED-seal (ISO 1179) / EO 24° cone end

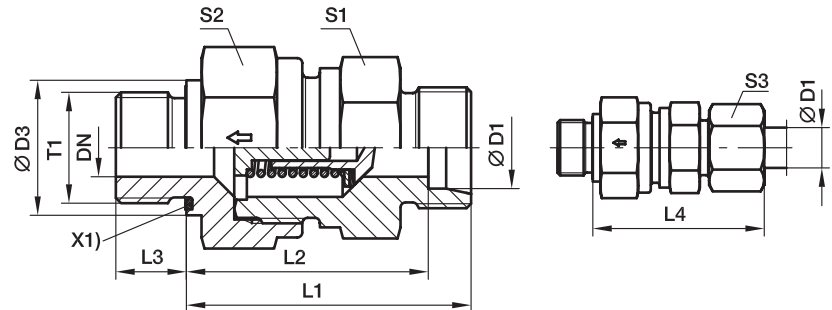

X1) Eolastic sealing

Series	D1	T1	CF DN	71 DN	D3	L1	L2	L3	L4	S1	CF S2	71 S2	S3	Weight g/1 piece	Order code*	PN (bar) ¹⁾	
																CF	71
L ³⁾	06	G 1/8 A	3.5	3.5	14	33.5	26.5	8	41.0	17	17	17	14	44	RHZ06LREDOMD	400	250
	08	G 1/4 A	5.5	5.5	19	35.5	28.5	12	43.0	19	19	19	17	59	RHZ08LREDOMD	400	250
	10	G 1/4 A	7.5	7.5	19	46.0	38.5	12	53.0	22	24	24	19	125	RHZ10LREDOMD	400	250
	12	G 3/8 A	9.5	9.5	22	48.0	40.5	12	55.0	27	30	30	22	161	RHZ12LREDOMD	400	250
	15	G 1/2 A	11.0	11.5	27	50.0	42.5	14	57.5	27	32	32	27	186	RHZ15LREDOMD	400	250
	18	G 1/2 A	14.0	14.0	27	56.0	48.0	14	64.0	36	41	36	32	275	RHZ18LREDOMD	400	160
	22	G 3/4 A	18.0	18.0	32	64.0	56.0	16	72.0	41	46	46	36	463	RHZ22LREDOMD	250	160
	28	G 1 A	23.0	23.0	40	72.0	64.0	18	80.5	50	55	55	41	721	RHZ28LREDOMD	250	100
	35	G 1 1/4 A	29.0	29.0	50	81.0	70.0	20	91.5	60	65	65	50	1073	RHZ35LREDOMD	250	100
	42	G 1 1/2 A	29.0	29.0	55	82.0	70.5	22	93.0	65	70	70	60	1602	RHZ42LREDOMD	250	100
S ⁴⁾	06	G 1/4 A	3.5	3.5	19	38.5	31.5	12	46.0	19	19	19	17	71	RHZ06SREDOMD	420	400
	08	G 1/4 A	3.5	3.5	19	38.5	31.5	12	46.0	19	19	19	19	74	RHZ08SREDOMD	420	400
	10	G 3/8 A	5.5	5.5	22	45.5	38.0	12	54.0	22	24	24	22	128	RHZ10SREDOMD	420	400
	12	G 3/8 A	7.5	7.5	22	48.5	41.0	12	57.0	24	27	27	24	152	RHZ12SREDOMD	420	400
	16	G 1/2 A	11.0	11.5	27	55.0	46.0	14	64.0	32	36	36	30	275	RHZ16SREDOMD	420	315
	20	G 3/4 A	15.0	15.0	32	61.0	50.0	16	71.5	41	50	46	36	490	RHZ20SREDOMD	420	250
	25	G 1 A	19.0	19.0	40	67.0	54.5	18	78.5	46	55	50	46	647	RHZ25SREDOMD	420	250
	30	G 1 1/4 A	24.0	24.0	50	78.0	64.0	20	90.5	60	60	60	50	1180	RHZ30SREDOMD	250	250
38	G 1 1/2 A	29.0	29.0	55	88.0	71.5	22	102.0	65	70	70	60	1670	RHZ38SREDOMD	250	250	

¹⁾ Pressure shown = item deliverable

³⁾ L = light series; ⁴⁾ S = heavy series

$\frac{PN \text{ (bar)}}{10} = PN \text{ (MPa)}$

Delivery without nut and ring. Information on ordering complete fittings or alternative sealing materials see page 17.

*Please add the **suffixes** below according to the material/surface required.

Order code suffixes			
Material	Suffix surface and material	Example	Standard sealing material (no additional suffix needed)
Steel, zinc plated, Cr(VI)-free	CF	RHZ06LREDOMDCF	NBR
Stainless steel	71	RHZ06LREDOMD71	VIT

RHV-M-ED Non return valve

EO 24° cone end / Male metric thread – ED-seal (ISO 9974)

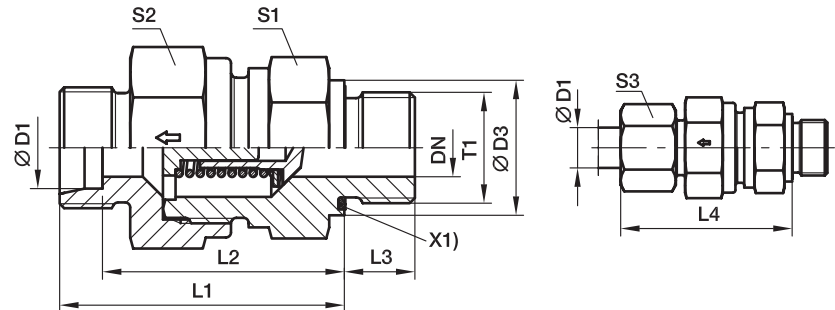

X1) Eolastic sealing

Series	D1	T1	CF DN	71 DN	D3	L1	L2	L3	L4	S1	CF S2	71 S2	S3	Weight g/1 piece	Order code*	PN (bar) ¹⁾	
																CF	71
L ³⁾	06	M 10×1.0	3.5	3.5	14	35.0	28.0	8	42.5	17	17	17	14	46	RHV06LMEDOMD	400	250
	08	M 12×1.5	5.5	5.5	17	37.0	29.5	12	43.5	19	19	19	17	58	RHV08LMEDOMD	400	250
	10	M 14×1.5	7.5	7.5	19	46.0	38.5	12	53.0	22	24	44	19	108	RHV10LMEDOMD	400	250
	12	M 16×1.5	9.5	9.5	22	50.0	42.5	12	57.0	27	30	30	22	173	RHV12LMEDOMD	400	250
	15	M 18×1.5	11.0	11.5	24	53.0	45.5	12	60.5	27	32	32	27	192	RHV15LMEDOMD	400	250
	18	M 22×1.5	14.0	14.0	27	58.0	50.0	14	66.0	36	41	36	32	298	RHV18LMEDOMD	400	160
	22	M 26×1.5	18.0	18.0	32	63.0	55.0	16	71.0	41	46	46	36	446	RHV22LMEDOMD	250	160
	28	M 33×2.0	23.0	23.0	40	71.0	63.0	18	79.5	50	55	55	41	722	RHV28LMEDOMD	250	100
	35	M 42×2.0	29.0	29.0	50	80.0	69.0	20	90.5	60	65	65	50	1053	RHV35LMEDOMD	250	100
	42	M 48×2.0	29.0	29.0	55	80.0	68.5	22	91.0	65	70	70	60	1563	RHV42LMEDOMD	250	100
S ⁴⁾	06	M 12×1.5	3.5	3.5	17	38.5	31.5	12	46.0	19	19	19	17	70	RHV06SMEDOMD	420	400
	08	M 14×1.5	3.5	3.5	19	38.5	31.5	12	46.0	19	19	19	19	76	RHV08SMEDOMD	420	400
	10	M 16×1.5	5.5	5.5	22	45.5	38.0	12	54.0	22	24	24	22	124	RHV10SMEDOMD	420	400
	12	M 18×1.5	7.5	7.5	24	48.5	41.0	12	57.0	24	27	27	24	157	RHV12SMEDOMD	420	400
	16	M 22×1.5	11.0	11.5	27	57.0	48.0	14	66.0	32	36	36	30	296	RHV16SMEDOMD	420	315
	20	M 27×2.0	15.0	15.0	32	63.0	52.0	16	73.5	41	50	46	36	521	RHV20SMEDOMD	420	250
	25	M 33×2.0	19.0	19.0	40	67.0	54.5	18	78.5	46	55	50	46	648	RHV25SMEDOMD	420	250
	30	M 42×2.0	24.0	24.0	50	78.0	64.0	20	90.5	60	60	60	50	1178	RHV30SMEDOMD	250	250
	38	M 48×2.0	29.0	29.0	55	86.0	69.5	22	100.0	65	70	70	60	1627	RHV38SMEDOMD	250	250

¹⁾Pressure shown = item deliverable

³⁾L = light series; ⁴⁾S = heavy series

$$\frac{PN \text{ (bar)}}{10} = PN \text{ (MPa)}$$

Delivery without nut and ring. Information on ordering complete fittings or alternative sealing materials see page 17.

*Please add the suffixes below according to the material/surface required.

Order code suffixes			
Material	Suffix surface and material	Example	Standard sealing material (no additional suffix needed)
Steel, zinc plated, Cr(VI)-free	CF	RHV06LMEDOMDCF	NBR
Stainless steel	71	RHV06LMEDOMD71	VIT

RHZ-M-ED Non return valve

Male metric thread – ED-seal (ISO 9974) / EO 24° cone end

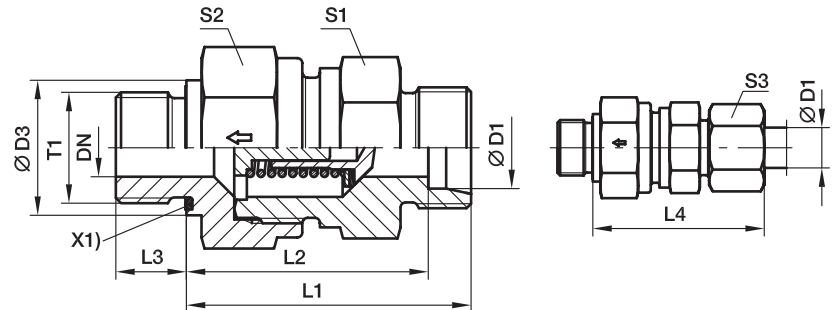

X1) Eolastic sealing

Series	D1	T1	CF DN	71 DN	D3	L1	L2	L3	L4	S1	CF S2	71 S2	S3	Weight g/1 piece	Order code*	PN (bar) ¹⁾	
																CF	71
L ³⁾	06	M 10×1.0	3.5	3.5	14	33.5	26.5	8	41.0	17	17	17	14	44	RHZ06LMEDOMD	400	250
	08	M 12×1.5	5.5	5.5	17	35.5	28.5	12	43.0	19	19	19	17	58	RHZ08LMEDOMD	400	250
	10	M 14×1.5	7.5	7.5	19	46.0	38.5	12	53.0	22	24	24	19	104	RHZ10LMEDOMD	400	250
	12	M 16×1.5	9.5	9.5	22	48.0	40.5	12	55.0	27	30	30	22	169	RHZ12LMEDOMD	400	250
	15	M 18×1.5	11.0	11.5	24	50.0	42.5	12	57.5	27	32	32	27	174	RHZ15LMEDOMD	400	250
	18	M 22×1.5	14.0	14.0	27	56.0	48.0	14	64.0	36	41	36	32	279	RHZ18LMEDOMD	400	160
	22	M 26×1.5	18.0	18.0	32	64.0	56.0	16	72.0	41	46	46	36	459	RHZ22LMEDOMD	250	160
	28	M 33×2.0	23.0	23.0	40	72.0	64.0	18	80.5	50	55	55	41	721	RHZ28LMEDOMD	250	100
	35	M 42×2.0	29.0	29.0	50	81.0	70.0	20	91.5	60	65	65	50	1078	RHZ35LMEDOMD	250	100
	42	M 48×2.0	29.0	29.0	55	82.0	70.5	22	93.0	65	70	70	60	1601	RHZ42LMEDOMD	250	100
S ⁴⁾	06	M 12×1.5	3.5	3.5	17	38.5	31.5	12	46.0	19	19	19	17	70	RHZ06SMEDOMD	420	400
	08	M 14×1.5	3.5	3.5	19	38.5	31.5	12	46.0	19	19	19	19	75	RHZ08SMEDOMD	420	400
	10	M 16×1.5	5.5	5.5	22	45.5	38.0	12	54.0	22	24	24	22	123	RHZ10SMEDOMD	420	400
	12	M 18×1.5	7.5	7.5	24	48.5	41.0	12	57.0	24	27	27	24	157	RHZ12SMEDOMD	420	400
	16	M 22×1.5	11.0	11.5	27	55.0	46.0	14	64.0	32	36	36	30	279	RHZ16SMEDOMD	420	315
	20	M 27×2.0	15.0	15.0	32	61.0	50.0	16	71.5	41	50	46	36	487	RHZ20SMEDOMD	420	250
	25	M 33×2.0	19.0	19.0	40	67.0	54.5	18	78.5	46	55	50	46	647	RHZ25SMEDOMD	420	250
	30	M 42×2.0	24.0	24.0	50	78.0	64.0	20	90.5	60	60	60	50	1180	RHZ30SMEDOMD	250	250
38	M 48×2.0	29.0	29.0	55	88.0	71.5	22	102.0	65	70	70	60	1669	RHZ38SMEDOMD	250	250	

¹⁾ Pressure shown = item deliverable

³⁾ L = light series; ⁴⁾ S = heavy series

$$\frac{\text{PN (bar)}}{10} = \text{PN (MPa)}$$

Delivery without nut and ring. Information on ordering complete fittings or alternative sealing materials see page 17.

*Please add the **suffixes** below according to the material/surface required.

Order code suffixes			
Material	Suffix surface and material	Example	Standard sealing material (no additional suffix needed)
Steel, zinc plated, Cr(VI)-free	CF	RHZ06LMEDOMDCF	NBR
Stainless steel	71	RHZ06LMEDOMD71	VIT

RHDI Non return valve

Female BSPP thread (ISO 1179-1) / Female BSPP thread (ISO 1179-1)

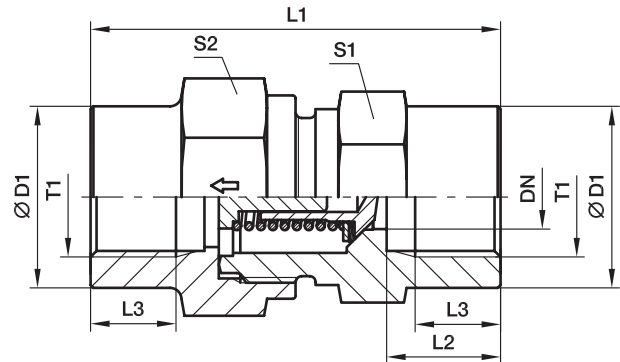

Series	T1	DN	D1	L1	L2	L3	S1	S2	Weight g/1 piece	Order code*	PN (bar) ¹⁾	
											CF	71
L ³⁾	G 1/8	3.5	19	42.5	12.0	8.0	19	19	76	RHDI1/8	400	400
	G 1/4	3.5	19	51.0	16.0	12.0	19	19	82	RHDI1/4	400	400
	G 3/8	7.5	24	60.0	17.0	12.0	24	27	157	RHDI3/8	400	400
	G 1/2	11.5	32	72.0	20.0	15.0	32	36	344	RHDI1/2	315	315
	G 3/4	15.0	41	84.0	22.0	16.5	41	46	664	RHDI3/4	250	250
	G 1	19.0	46	95.0	25.5	19.0	46	50	821	RHDI1	250	250
	G 1 1/4	24.0	60	110.0	28.0	21.5	60	60	1581	RHDI11/4	250	250
	G 1 1/2	29.0	65	114.0	28.5	22.0	65	70	1919	RHDI11/2	250	250

¹⁾Pressure shown = item deliverable

³⁾L = light series

$$\frac{\text{PN (bar)}}{10} = \text{PN (MPa)}$$

Delivery without nut and ring. Information on ordering complete fittings or alternative sealing materials see page 17.

*Please add the **suffixes** below according to the material/surface required.

Order code suffixes			
Material	Suffix surface and material	Example	Standard sealing material (no additional suffix needed)
Steel, zinc plated, Cr(VI)-free	CF	RHDI1/8CF	NBR
Stainless steel	71	RHDI1/871	VIT

RVP Non return valve cartridge

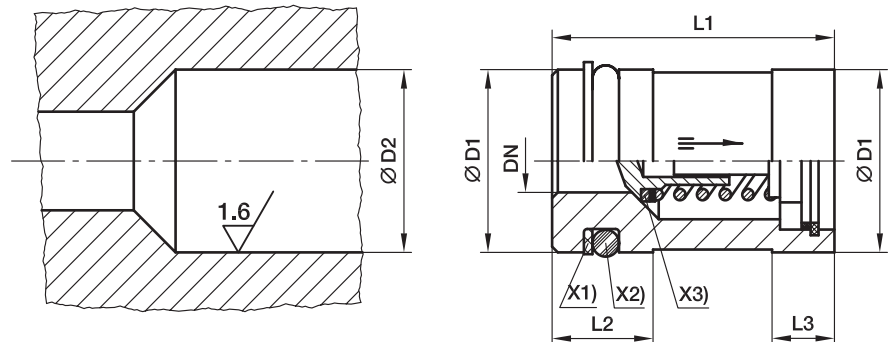

- X1) Supporting ring PTFE
 X2) O-ring NBR
 X3) Sealing disc NBR

Valve ITL	DN	D1	D2	L1 ± 0,15	L2	L3	O-ring	Supporting ring	Weight g/1 piece	Order code*	PN (bar) ¹⁾	
											CF	71
6-L/6 & 8-S	3.5	12.945 ± 0.055	13 ^{+0.12 +0.05}	23.15	9.5	6.0	8.3×2.4	SRA 13-2.05-1.0	21	RVP13	420	400
8-L/10-S	5.5	15.945 ± 0.055	16 ^{+0.12 +0.05}	26.65	9.5	6.5	11.3×2.4	SRA 16-2.05-1.0	32	RVP16	420	400
10-L/12-S	7.5	19.935 ± 0.065	20 ^{+0.142 +0.065}	30.15	9.5	6.5	15.3×2.4	SRA 20-2.05-1.0	54	RVP20	420	400
12-L/14-S	9.5	23.935 ± 0.065	24 ^{+0.149 +0.065}	35.15	12.0	7.5	18.2×3	SRA 24-2.6-1.0	80	RVP24	420	315
15-L/16-S	11.5	26.935 ± 0.065	27 ^{+0.149 +0.065}	38.15	12.0	7.5	21.2×3	SRA 27-2.6-1.0	105	RVP27	420	315
18-L/20-S	15.0	34.92 ± 0.08	35 ^{+0.18 +0.08}	44.65	12.0	9.5	29.2×3	SRA 35-2.5-1.0	204	RVP35	420	250
22-L/25-S	19.0	39.92 ± 0.08	40 ^{+0.18 +0.08}	50.65	12.0	11.0	34.2×3	SRA 40-2.5-1.0	275	RVP40	420	250
28-L/30-S	24.0	46.92 ± 0.08	47 ^{+0.18 +0.08}	60.15	13.0	13.0	41.0×3	SRA 47-2.6-1.5	412	RVP47	250	250
35-L/38-S	29.0	54.905 ± 0.095	55 ^{+0.22 +0.01}	70.15	16.0	13.0	44.2×5.7	SRA 55-5.1-1.5	607	RVP55	250	250

¹⁾ Pressure shown = item deliverable

$$\frac{\text{PN (bar)}}{10} = \text{PN (MPa)}$$

Delivery without nut and ring. Information on ordering complete fittings or alternative sealing materials see page 17.

*Please add the **suffixes** below according to the material/surface required.

Order code suffixes			
Material	Suffix surface and material	Example	Standard sealing material (no additional suffix needed)
Steel, zinc plated, Cr(VI)-free	CF	RVP13CF	NBR
Stainless steel	71	RVP1371	VIT

I-TL Internal parts of non return valve

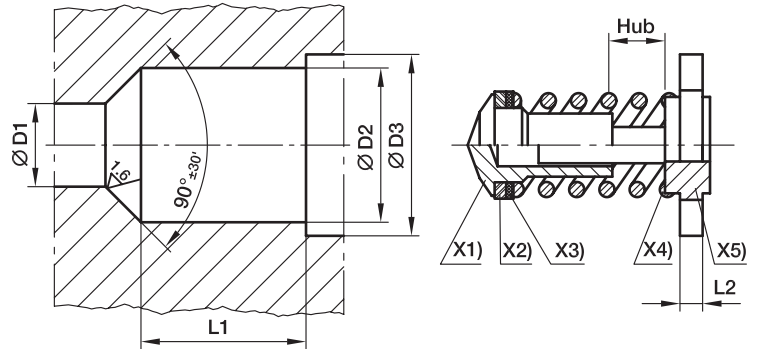

- X1) poppet
- X2) sealing disc (smooth side to the poppet)
- X3) cover disc
- X4) spring
- X5) passage disc

Series	Tube O.D.	D1+0.1	D2+0.1	D3+0.1	L1±0.1	L2	Hub	Weight g/1 piece	Order code*	PN (bar) ¹⁾	
										CF	71
L/S/S	06/06/08	3.5	7.5	8.6	8.2	2.0	1.0	2	ITL06L/06+08S	*	*
L/S	08/10	5.5	10.2	11.6	11.0	2.0	1.7	4	ITL08L/10S	*	*
L/S	10/12	7.5	13.0	14.1	14.0	2.0	2.3	7	ITL10L/12S	*	*
L/S	12/14	9.5	16.7	18.1	16.5	2.5	2.9	13	ITL12L/14S	*	*
L/S	15/16	11.5	19.5	20.6	19.0	2.5	3.5	18	ITL15L/16S	*	*
L/S	18/20	15.0	25.2	27.1	22.5	3.0	4.4	37	ITL18L/20S	*	*
L/S	22/25	19.0	30.8	32.6	27.0	3.0	5.5	54	ITL22L/25S	*	*
L/S	28/30	24.0	38.6	40.6	32.5	3.5	7.3	107	ITL28L/30S	*	*
L/L/S	35/38/42	29.0	45.7	48.1	37.5	3.5	8.9	144	ITL35L+42I/38S	*	*

* = item deliverable

Delivery without nut and ring. Information on ordering complete fittings or alternative sealing materials see page 17.

*Please add the **suffixes** below according to the material/surface required.

Order code suffixes			
Material	Suffix surface and material	Example	Standard sealing material (no additional suffix needed)
Steel, zinc plated, Cr(VI)-free	CF	ITL06L/06+08S	NBR
Stainless steel	71	ITL06L71/06+08S	VIT

RHD/V/Z Non return valves with O-Lok® or Triple-Lok® connections

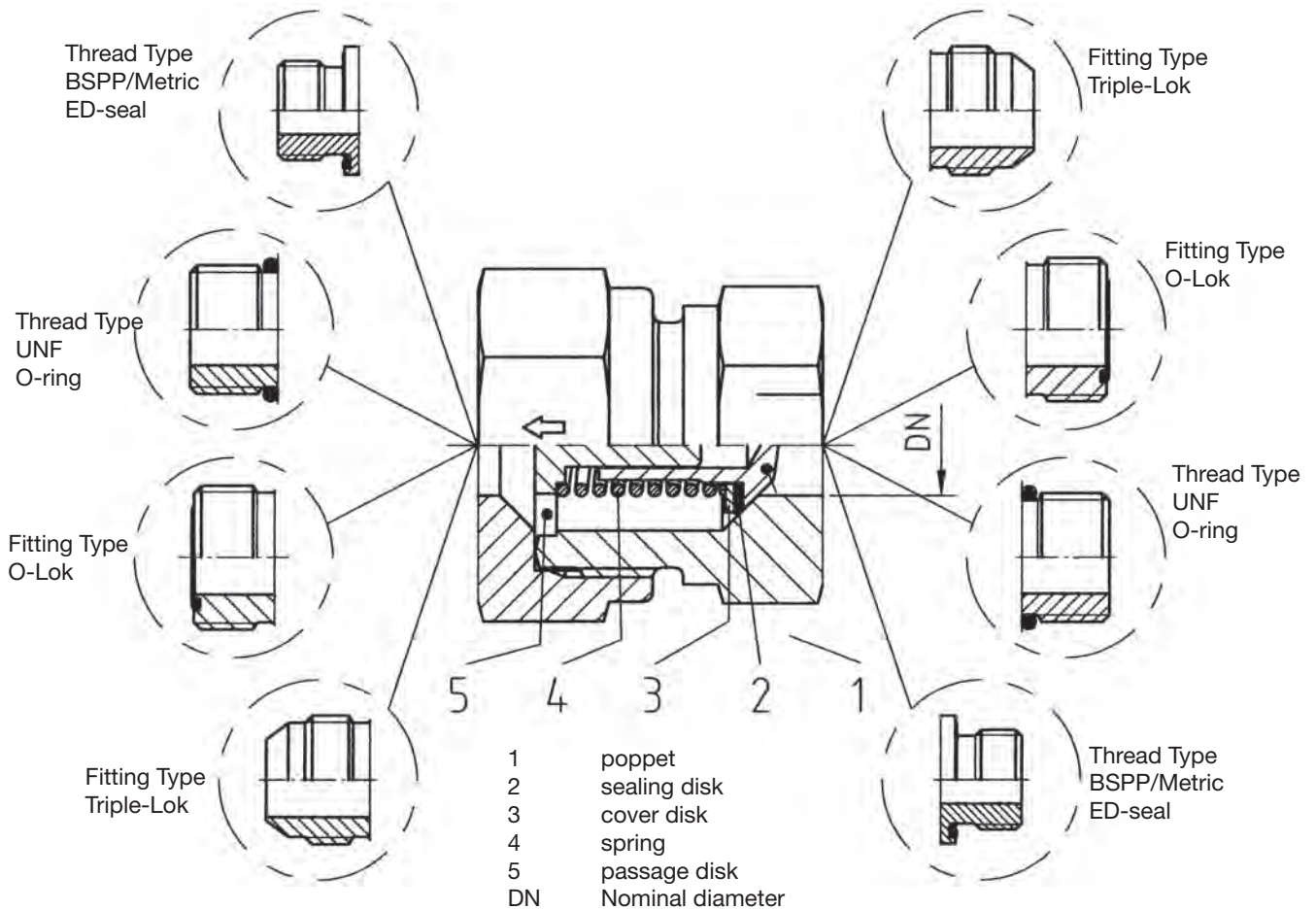

Material:

- Steel zinc-plated CF Cr(VI)-free, seals in NBR (e.g. Perbunan)
- Internal parts in stainless steel with FKM also available on request.

Perbunan = registered trademark of Bayer

RHDMLOS Non return valve

O-Lok® ORFS end / O-Lok® ORFS end

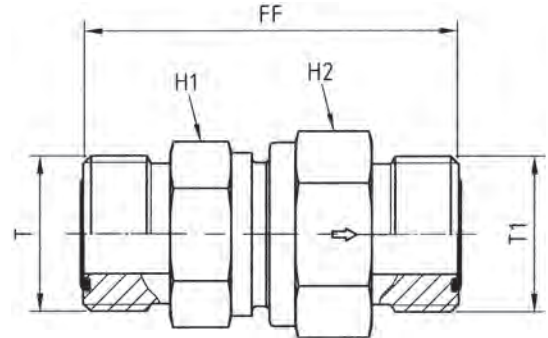

Tube 1 O.D.		Tube 2 O.D.		ORFS (UN/UNF) thread T	ORFS (UN/UNF) thread T1	H1	H2	FF	DN (Nom. diam.)	Weight g/1 piece	Order code*	PN (bar) ¹⁾
mm	Inch	mm	Inch									CF
6	1/4	6	1/4	9/16-18 UNF	9/16-18 UNF	19	19	44.5	3.5	108	4RHDMLOS	420
8, 10	5/16, 3/8	8, 10	5/16, 3/8	11/16-16 UNF	11/16-16 UNF	22	24	53.5	5.5	188	6RHDMLOS	420
12	1/2	12	1/2	13/16-16 UNF	13/16-16 UNF	24	27	59.5	7.5	223	8RHDMLOS	420
14, 15, 16	5/8	14, 15, 16	5/8	1-14 UNF	1-14 UNF	32	36	70.5	11.5	428	10RHDMLOS	420
18, 20	3/4	18, 20	3/4	1 3/16-12 UNF	1 3/16-12 UNF	41	46	77.5	15.0	731	12RHDMLOS	420
22, 25	1	22, 25	1	1 7/16-12 UNF	1 7/16-12 UNF	46	50	81.5	19.0	1076	16RHDMLOS	420
28, 30, 32	1 1/4	28, 30, 32	1 1/4	1 11/16-12 UNF	1 11/16-12 UNF	60	60	91.5	24.0	1630	20RHDMLOS	250
35, 38	1 1/2	35, 38	1 1/2	2-12 UNF	2-12 UNF	65	70	98.5	29.0	2362	24RHDMLOS	250

¹⁾Pressure shown = item deliverable

$$\frac{\text{PN (bar)}}{10} = \text{PN (MPa)}$$

Information on ordering complete fittings or alternative sealing materials see page 17.

*Please add the **suffixes** below according to the material/surface required.

Order code suffixes			
Material	Suffix surface and material	Example	Standard sealing material (no additional suffix needed)
Steel, zinc plated, Cr(VI)-free	CF	4RHDMLOSCF	NBR

RHV42EDMLOS Non return valve

Male BSPP thread – ED-seal (ISO 1179) / O-Lok® ORFS end

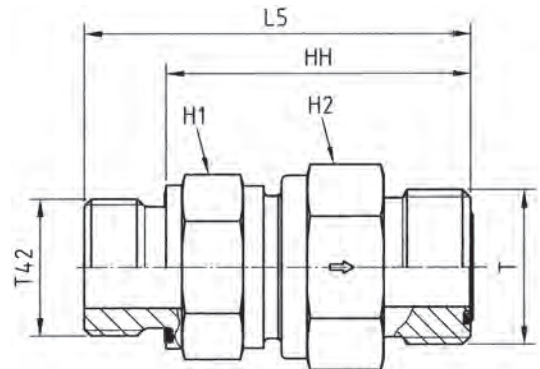

Tube O.D.		BSPP thread	ORFS (UN/UNF)	H1	H2	L5	HH	DN (Nom. diam.)	Weight g/1 piece	Order code*	PN (bar) ¹⁾
mm	Inch										T42
6	1/4	G 1/8	9/16-18 UNF	19	19	44.5	36.5	3.5	92	4RHV42EDMLOS	420
8, 10	5/16, 3/8	G 1/4	11/16-16 UNF	24	27	56.5	44.5	6.5	165	6RHV42EDMLOS	420
12	1/2	G 3/8	13/16-16 UNF	24	27	61.5	49.5	7.5	191	8RHV42EDMLOS	420
14, 15, 16	5/8	G 1/2	1-14 UNF	32	36	70.0	56.0	11.5	366	10RHV42EDMLOS	420
18, 20	3/4	G 3/4	1 3/16-12 UNF	41	46	77.5	63.5	15.0	631	12RHV42EDMLOS	420
22, 25	1	G 1	1 7/16-12 UNF	46	50	84.0	66.0	19.0	863	16RHV42EDMLOS	420
28, 30, 32	1 1/4	G 1 1/4	1 11/16-12 UNF	60	60	95.0	75.0	24.0	1403	20RHV42EDMLOS	250
35, 38	1 1/2	G 1 1/2	2-12 UNF	65	70	105.0	83.0	29.0	1969	24RHV42EDMLOS	250

¹⁾Pressure shown = item deliverable

$\frac{\text{PN (bar)}}{10} = \text{PN (MPa)}$

Information on ordering complete fittings or alternative sealing materials see page 17.

*Please add the **suffixes** below according to the material/surface required.

Order code suffixes			
Material	Suffix surface and material	Example	Standard sealing material (no additional suffix needed)
Steel, zinc plated, Cr(VI)-free	CF	4RHV42EDMLOSCF	NBR

RHZ42EDMLOS Non return valve

O-Lok® ORFS end / Male BSPP thread – ED-seal (ISO 1179)

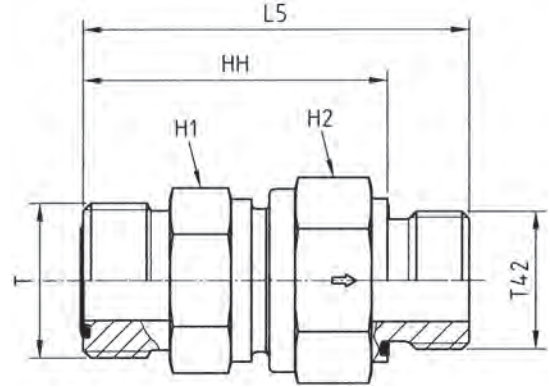

Tube O.D.		BSPP thread	ORFS (UN/UNF) thread	H1	H2	L5	HH	DN (Nom. diam.)	Weight g/1 piece	Order code*	PN (bar) ¹⁾
mm	Inch	T42	T								CF
6	1/4	G 1/8	9/16-18 UNF	19	19	44.5	36.5	3.5	91	4RHZ42EDMLOS	420
8, 10	5/16, 3/8	G 1/4	11/16-16 UNF	24	27	56.5	44.5	6.5	161	6RHZ42EDMLOS	420
12	1/2	G 3/8	13/16-16 UNF	24	27	61.5	49.5	7.5	190	8RHZ42EDMLOS	420
14, 15, 16	5/8	G 1/2	1-14 UNF	32	36	70.0	56.0	11.5	348	10RHZ42EDMLOS	420
18, 20	3/4	G 3/4	1 3/16-12 UNF	41	46	77.5	53.5	15.0	634	12RHZ42EDMLOS	420
22, 25	1	G 1	1 7/16-12 UNF	46	50	84.0	66.0	19.0	863	16RHZ42EDMLOS	420
28, 30, 32	1 1/4	G 1 1/4	1 11/16-12 UNF	60	60	95.0	75.0	24.0	1397	20RHZ42EDMLOS	250
35, 38	1 1/2	G 1 1/2	2-12 UNF	65	70	105.0	83.0	29.0	2001	24RHZ42EDMLOS	250

¹⁾Pressure shown = item deliverable

$$\frac{\text{PN (bar)}}{10} = \text{PN (MPa)}$$

Information on ordering complete fittings or alternative sealing materials see page 17.

*Please add the **suffixes** below according to the material/surface required.

Order code suffixes			
Material	Suffix surface and material	Example	Standard sealing material (no additional suffix needed)
Steel, zinc plated, Cr(VI)-free	CF	4RHZ42EDMLOSCF	NBR

RHV5OMLOS Non return valve

Male UN/UNF thread – O-ring (ISO 11926) / O-Lok® ORFS end

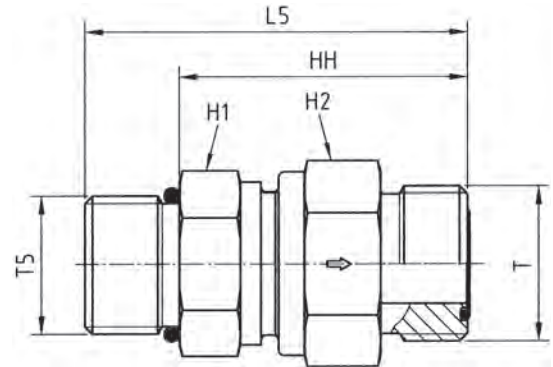

Tube O.D.		UNF male thread T5	ORFS (UN/UNF) thread T	H1	H2	L5	HH	DN (Nom. diam.)	Weight g/1 piece	Order code*	PN (bar) ¹⁾
mm	Inch										CF
6	1/4	7/16-20 UNF	9/16-18 UNF	19	19	45.5	34.5	3.5	92	4RHV5OMLOS	420
8, 10	5/16, 3/8	9/16-18 UNF	11/16-16 UNF	22	24	54.5	42.5	5.5	165	6RHV5OMLOS	420
12	1/2	3/4-16 UNF	13/16-16 UNF	24	27	60.5	46.5	5.5	165	8RHV5OMLOS	420
14, 15, 16	5/8	7/8-14 UNF	1-14 UNF	32	36	71.0	55.0	11.5	366	10RHV5OMLOS	420
18, 20	3/4	1 1/16-12 UN	1 3/16-12 UNF	41	46	79.0	60.5	15.0	631	12RHV5OMLOS	420
22, 25	1	1 5/16-12 UN	1 7/16-12 UNF	46	50	82.5	64.0	19.0	863	16RHV5OMLOS	420
28, 30, 32	1 1/4	1 5/8-12 UN	1 11/16-12 UNF	60	60	92.5	74.0	24.0	1403	20RHV5OMLOS	250
35, 38	1 1/2	1 7/8-12 UN	2-12 UNF	65	70	99.5	81.0	29.0	1969	24RHV5OMLOS	250

¹⁾ Pressure shown = item deliverable

$$\frac{\text{PN (bar)}}{10} = \text{PN (MPa)}$$

Information on ordering complete fittings or alternative sealing materials see page 17.

*Please add the **suffixes** below according to the material/surface required.

Order code suffixes			
Material	Suffix surface and material	Example	Standard sealing material (no additional suffix needed)
Steel, zinc plated, Cr(VI)-free	CF	RHV5OMLOSCF	NBR

RHZ50MLOS Non return valve

O-Lok® ORFS end / Male UN/UNF thread – O-ring (ISO 11926)

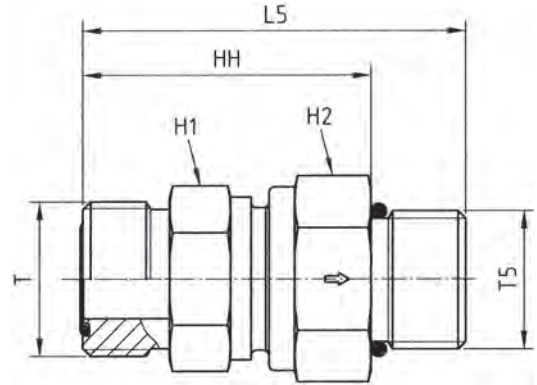

Tube O.D.		UNF male thread T5	ORFS (UN/UNF) thread T	H1	H2	L5	HH	DN (Nom. diam.)	Weight g/1 piece	Order code*	PN (bar) ¹⁾
mm	Inch										CF
6	1/4	7/16-20 UNF	9/16-18 UNF	19	19	45.5	34.5	3.5	91	4RHZ50MLOS	420
8, 10	5/16, 3/8	9/16-18 UNF	11/16-16 UNF	22	24	54.5	42.5	5.5	161	6RHZ50MLOS	420
12	1/2	3/4-16 UNF	13/16-16 UNF	24	27	60.5	46.5	5.5	161	8RHZ50MLOS	420
14, 15, 16	5/8	7/8-14 UNF	1-14 UNF	32	36	71.0	55.0	11.5	348	10RHZ50MLOS	420
18, 20	3/4	1 1/16-12 UN	1 3/16-12 UNF	41	46	79.0	60.5	15.0	634	12RHZ50MLOS	420
22, 25	1	1 5/16-12 UN	1 7/16-12 UNF	46	50	82.5	64.0	19.0	863	16RHZ50MLOS	420
28, 30, 32	1 1/4	1 5/8-12 UN	1 11/16-12 UNF	60	60	92.5	74.0	24.0	1397	20RHZ50MLOS	250
35, 38	1 1/2	1 7/8-12 UN	2-12 UNF	65	70	99.5	81.0	29.0	2001	24RHZ50MLOS	250

¹⁾ Pressure shown = item deliverable

$$\frac{PN \text{ (bar)}}{10} = PN \text{ (MPa)}$$

Information on ordering complete fittings or alternative sealing materials see page 17.

*Please add the **suffixes** below according to the material/surface required.

Order code suffixes			
Material	Suffix surface and material	Example	Standard sealing material (no additional suffix needed)
Steel, zinc plated, Cr(VI)-free	CF	4RHZ50MLOSCF	NBR

RHV82EDMLOS Non return valve

Male metric thread – ED-seal (ISO 9974) / O-Lok® ORFS end

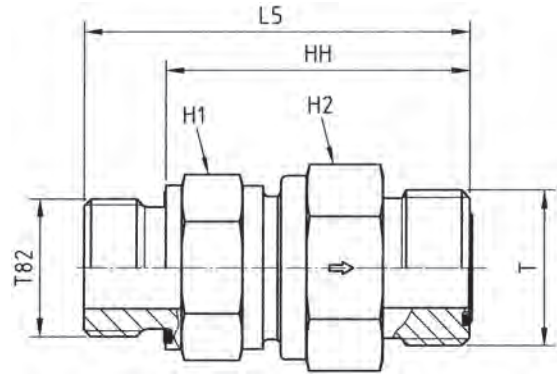

Tube O.D.		metric thread T82	ORFS (UN/UNF) thread T	H1	H2	L5	HH	DN (Nom. diam.)	Weight g/1 piece	Order code*	PN (bar) ¹⁾
mm	Inch										CF
6	1/4	M 12×1.5	9/16-18 UNF	19	19	48.5	36.5	3.5	89	4M12RHV82EDMLOS	420
8, 10	5/16, 3/8	M 16×1.5	11/16-16 UNF	22	24	56.5	44.5	5.5	157	6M16RHV82EDMLOS	420
12	1/2	M 18×1.5	13/16-16 UNF	24	27	61.5	49.5	7.5	195	8M18RHV82EDMLOS	420
14, 15, 16	5/8	M 22×1.5	1-14 UNF	32	36	72.0	58.0	11.5	369	10M22RHV82EDMLOS	420
18, 20	3/4	M 27×2.0	1 3/16-12 UNF	41	46	79.5	63.5	15.0	628	12M27RHV82EDMLOS	420
22, 25	1	M 33×2.0	1 7/16-12 UNF	46	50	84.0	66.0	19.0	867	16M33RHV82EDMLOS	420
28, 30, 32	1 1/4	M 42×2.0	1 11/16-12 UNF	60	60	95.0	75.0	24.0	1409	20M42RHV82EDMLOS	250
35, 38	1 1/2	M 48×2.0	2-12 UNF	65	70	103.0	81.0	29.0	1970	24M48RHV82EDMLOS	250

¹⁾ Pressure shown = item deliverable

$\frac{\text{PN (bar)}}{10} = \text{PN (MPa)}$

Information on ordering complete fittings or alternative sealing materials see page 17.

*Please add the **suffixes** below according to the material/surface required.

Order code suffixes			
Material	Suffix surface and material	Example	Standard sealing material (no additional suffix needed)
Steel, zinc plated, Cr(VI)-free	CF	4M12RHV82EDMLOS	NBR

RHZ82EDMLOS Non return valve

O-Lok® ORFS end / Male metric thread – ED-seal (ISO 9974)

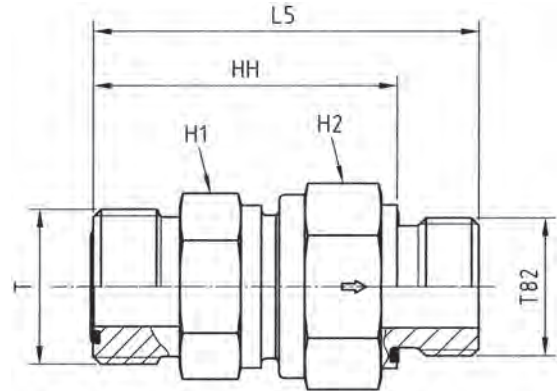

Tube O.D.		metric thread T82	ORFS (UN/UNF) thread T	H1	H2	L5	HH	DN (Nom. diam.)	Weight g/1 piece	Order code*	PN (bar) ¹⁾
mm	Inch										CF
6	1/4	M 12×1.5	9/16-18 UNF	19	19	48.5	36.5	3.5	89	4M12RHZ82EDMLOS	420
8, 10	5/16, 3/8	M 16×1.5	11/16-16 UNF	24	27	59.1	47.1	7.5	156	6M16RHZ82EDMLOS	420
12	1/2	M 18×1.5	13/16-16 UNF	24	27	61.5	49.5	7.5	195	8M18RHZ82EDMLOS	420
14, 15, 16	5/8	M 22×1.5	1-14 UNF	32	36	70.0	56.0	11.5	352	10M22RHZ82EDMLOS	420
18, 20	3/4	M 27×2.0	1 3/16-12 UNF	41	46	77.5	61.5	15.0	608	12M27RHZ82EDMLOS	420
22, 25	1	M 33×2.0	1 7/16-12 UNF	46	50	84.0	66.0	19.0	965	16M33RHZ82EDMLOS	420
28, 30, 32	1 1/4	M 42×2.0	1 11/16-12 UNF	60	60	95.0	75.0	24.0	1396	20M42RHZ82EDMLOS	250
35, 38	1 1/2	M 48×2.0	2-12 UNF	65	70	115.0	93.0	29.0	1978	24M48RHZ82EDMLOS	250

¹⁾Pressure shown = item deliverable

$$\frac{\text{PN (bar)}}{10} = \text{PN (MPa)}$$

Information on ordering complete fittings or alternative sealing materials see page 17.

*Please add the **suffixes** below according to the material/surface required.

Order code suffixes			
Material	Suffix surface and material	Example	Standard sealing material (no additional suffix needed)
Steel, zinc plated, Cr(VI)-free	CF	4M12RHZ82EDMLOSCF	NBR

RHDMTXS Non return valve

Triple-Lok® 37° flare end / Triple-Lok® 37° flare end

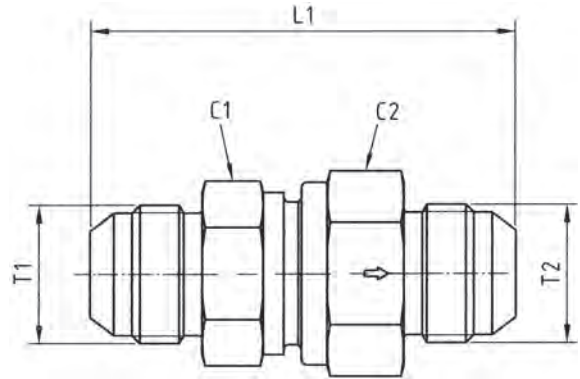

Tube 1 O.D.		Tube 2 O.D.		Thread JIC SAE T1	Thread JIC SAE T2	C1	C2	L1	DN (Nom. diam.)	Weight g/1 piece	Order code*	PN (bar) ¹⁾
mm	Inch	mm	Inch									CF
6	1/4	6	1/4	7/16-20 UNF	7/16-20 UNF	19	19	52.5	3.5	108	4RHDMTXS	420
8	5/16	8	5/16	1/2-20 UNF	1/2-20 UNF	22	24	59.5	5.5	188	5RHDMTXS	420
10	3/8	10	3/8	9/16-18 UNF	9/16-18 UNF	24	27	61.5	7.5	223	6RHDMTXS	420
12	1/2	12	1/2	3/4-16 UNF	3/4-16 UNF	27	32	69.5	9.5	324	8RHDMTXS	420
14, 15, 16	5/8	14, 15, 16	5/8	7/8-14 UNF	7/8-14 UNF	32	36	78.5	11.5	428	10RHDMTXS	350
18, 20	3/4	18, 20	3/4	1 1/16-12 UN	1 1/16-12 UN	41	46	87.5	15.0	731	12RHDMTXS	350
25	1	25	1	1 5/16-12 UN	1 5/16-12 UN	46	50	92.5	19.0	1076	16RHDMTXS	280
28, 30, 32	1 1/4	28, 30, 32	1 1/4	1 5/8-12 UN	1 5/8-12 UN	60	60	105.5	24.0	1630	20RHDMTXS	250
35, 38	1 1/2	35, 38	1 1/2	1 7/8-12 UN	1 7/8-12 UN	65	70	118.5	29.0	2362	24RHDMTXS	210

¹⁾Pressure shown = item deliverable

$$\frac{\text{PN (bar)}}{10} = \text{PN (MPa)}$$

Information on ordering complete fittings or alternative sealing materials see page I7.

*Please add the **suffixes** below according to the material/surface required.

Order code suffixes			
Material	Suffix surface and material	Example	Standard sealing material (no additional suffix needed)
Steel, zinc plated, Cr(VI)-free	CF	4RHDMTXSCF	NBR

RHV42EDMXS Non return valve

Male BSPP thread – ED-seal (ISO 1179) / Triple-Lok® 37° flare end

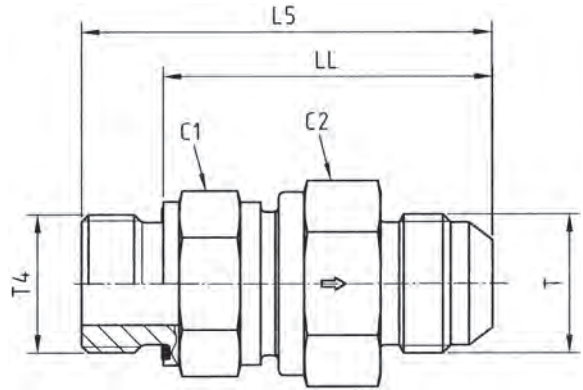

Tube O.D.		BSPP thread	Thread JIC SAE T	C1	C2	L5	LL	DN (Nom. diam.)	Weight g/1 piece	Order code*	PN (bar) ¹⁾
mm	Inch	T4	T							CF	
6	1/4	G 1/8	7/16-20 UNF	19	19	48.0	40.0	3.5	92	4RHV42EDMXS	420
8	5/16	G 1/4	1/2-20 UNF	22	24	59.5	47.5	5.5	165	5-4RHV42EDMXS	420
10	3/8	G 1/4	9/16-18 UNF	24	27	62.0	50.0	7.5	191	6RHV42EDMXS	420
12	1/2	G 3/8	3/4-16 UNF	27	32	67.0	55.0	9.5	277	8RHV42EDMXS	420
14, 15, 16	5/8	G 1/2	7/8-14 UNF	32	36	76.0	62.0	11.5	366	10RHV42EDMXS	350
18, 20	3/4	G 3/4	1 1/16-12 UN	41	46	84.5	68.5	15.0	631	12RHV42EDMXS	350
25	1	G 1	1 5/16-12 UN	46	50	89.5	71.5	19.0	863	16RHV42EDMXS	280
28, 30, 32	1 1/4	G 1 1/4	1 5/8-12 UN	60	60	102.0	82.0	24.0	1403	20RHV42EDMXS	250
35, 38	1 1/2	G 1 1/2	1 7/8-12 UN	65	70	113.0	91.0	29.0	1969	24RHV42EDMXS	210

¹⁾Pressure shown = item deliverable

$$\frac{\text{PN (bar)}}{10} = \text{PN (MPa)}$$

Information on ordering complete fittings or alternative sealing materials see page I7.

*Please add the **suffixes** below according to the material/surface required.

Order code suffixes			
Material	Suffix surface and material	Example	Standard sealing material (no additional suffix needed)
Steel, zinc plated, Cr(VI)-free	CF	4RHV42EDMXSCF	NBR

RHZ42EDMXS Non return valve

Triple-Lok® 37° flare end / Male BSPP thread – ED-seal (ISO 1179)

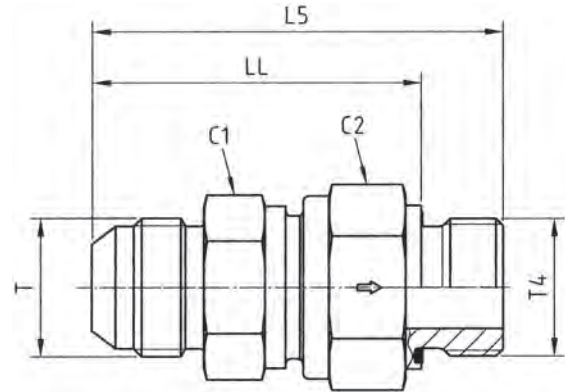

Tube O.D.		BSPP thread T4	Thread JIC SAE T	C1	C2	L5	LL	DN (Nom. diam.)	Weight g/1 piece	Order code*	PN (bar) ¹⁾
mm	Inch										CF
6	1/4	G 1/8	7/16-20 UNF	19	19	48.0	40.0	3.5	89	4RHZ42EDMXS	420
8	5/16	G 1/4	1/2-20 UNF	22	24	59.0	47.0	5.5	156	5-4RHZ42EDMXS	420
10	3/8	G 1/4	9/16-18 UNF	24	27	62.0	50.0	7.5	190	6RHZ42EDMXS	420
12	1/2	G 3/8	3/4-16 UNF	27	32	66.0	54.0	9.5	278	8RHZ42EDMXS	420
14, 15, 16	5/8	G 1/2	7/8-14 UNF	32	36	74.0	60.0	11.5	348	10RHZ42EDMXS	350
18, 20	3/4	G 3/4	1 1/16-12 UN	41	46	82.5	66.5	15.0	634	12RHZ42EDMXS	350
25	1	G 1	1 5/16-12 UN	46	50	89.5	71.5	19.0	863	16RHZ42EDMXS	280
28, 30, 32	1 1/4	G 1 1/4	1 5/8-12 UN	60	60	102.0	82.0	24.0	1397	20RHZ42EDMXS	250
35, 38	1 1/2	G 1 1/2	1 7/8-12 UN	65	70	115.0	93.0	29.0	2001	24RHZ42EDMXS	210

¹⁾Pressure shown = item deliverable

$$\frac{\text{PN (bar)}}{10} = \text{PN (MPa)}$$

Information on ordering complete fittings or alternative sealing materials see page I7.

*Please add the **suffixes** below according to the material/surface required.

Order code suffixes			
Material	Suffix surface and material	Example	Standard sealing material (no additional suffix needed)
Steel, zinc plated, Cr(VI)-free	CF	4RHZ42EDMXSCF	NBR

RHV5OMXS Non return valve

Male UN/UNF thread – O-ring (ISO 11926) / Triple-Lok® 37° flare end

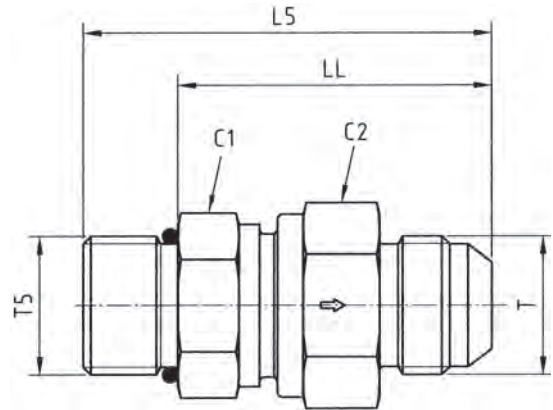

Tube O.D.		Thread UNF T5	Thread JIC SAE T	C1	C2	L5	LL	DN (Nom. diam.)	Weight g/1 piece	Order code*	PN (bar) ¹⁾
mm	Inch										CF
6	1/4	7/16-20 UNF	7/16-20 UNF	19	19	49.5	38.5	3.5	92	4RHV5OMXS	420
8	5/16	1/2-20 UNF	1/2-20 UNF	22	24	56.5	45.5	5.5	165	5RHV5OMXS	420
10	3/8	9/16-18 UNF	9/16-18 UNF	24	27	59.5	47.5	7.5	191	6RHV5OMXS	420
12	1/2	3/4-16 UNF	3/4-16 UNF	27	32	66.5	52.5	9.5	277	8RHV5OMXS	420
14, 15, 16	5/8	7/8-14 UNF	7/8-14 UNF	32	36	75.0	59.0	11.5	366	10RHV5OMXS	350
18, 20	3/4	1 1/16-12 UN	1 1/16-12 UN	41	46	84.0	65.5	15.0	631	12RHV5OMXS	350
25	1	1 5/16-12 UN	1 5/16-12 UN	46	50	88.0	69.5	19.0	863	16RHV5OMXS	280
28, 30, 32	1 1/4	1 5/8-12 UN	1 5/8-12 UN	60	60	99.5	81.0	24.0	1403	20RHV5OMXS	250
35, 38	1 1/2	1 7/8-12 UN	1 7/8-12 UN	65	70	109.5	91.0	29.0	1969	24RHV5OMXS	210

¹⁾Pressure shown = item deliverable

$$\frac{\text{PN (bar)}}{10} = \text{PN (MPa)}$$

Information on ordering complete fittings or alternative sealing materials see page I7.

*Please add the **suffixes** below according to the material/surface required.

Order code suffixes			
Material	Suffix surface and material	Example	Standard sealing material (no additional suffix needed)
Steel, zinc plated, Cr(VI)-free	CF	RHV5OMXSCF	NBR

RHZ5OMXS Non return valve

Triple-Lok® 37° flare end / Male UN/UNF thread – O-ring (ISO 11926)

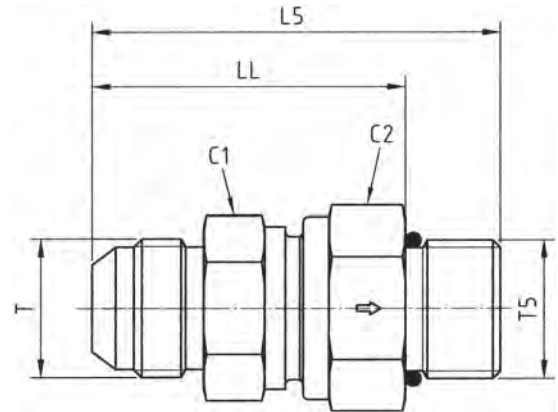

Tube O.D.		Thread UNF T5	Thread JIC SAE T	C1	C2	L5	LL	DN (Nom. diam.)	Weight g/1 piece	Order code*	PN (bar) ¹⁾
mm	Inch										CF
6	1/4	7/16-20 UNF	7/16-18 UNF	19	19	49.5	38.5	3.5	91	4RHZ5OMXS	420
8	5/16	1/2-20 UNF	1/2-20 UNF	22	24	56.5	45.5	5.5	161	5RHZ5OMXS	420
10	3/8	9/16-18 UNF	9/16-18 UNF	24	27	59.5	47.5	7.5	190	6RHZ5OMXS	420
12	1/2	3/4-16 UNF	3/4-16 UNF	27	32	66.5	52.5	9.5	278	8RHZ5OMXS	420
14, 15, 16	5/8	7/8-14 UNF	7/8-14 UNF	32	36	75.0	59.0	11.5	348	10RHZ5OMXS	350
18, 20	3/4	1 1/16-12 UN	1 1/16-12 UN	41	46	84.0	65.5	15.0	634	12RHZ5OMXS	350
25	1	1 5/16-12 UN	1 5/16-12 UN	46	50	88.0	69.5	19.0	863	16RHZ5OMXS	280
28, 30, 32	1 1/4	1 5/8-12 UN	1 5/8-12 UN	60	60	107.0	81.0	24.0	1397	20RHZ5OMXS	250
35, 38	1 1/2	1 7/8-12 UN	1 7/8-12 UN	65	70	109.5	91.0	29.0	2001	24RHZ5OMXS	210

¹⁾Pressure shown = item deliverable

$$\frac{\text{PN (bar)}}{10} = \text{PN (MPa)}$$

Information on ordering complete fittings or alternative sealing materials see page I7.

*Please add the **suffixes** below according to the material/surface required.

Order code suffixes			
Material	Suffix surface and material	Example	Standard sealing material (no additional suffix needed)
Steel, zinc plated, Cr(VI)-free	CF	4RHZ5OMXSFCF	NBR

RHV82EDMXS Non return valve

Male metric thread – ED-seal (ISO 9974) / Triple-Lok® 37° flare end

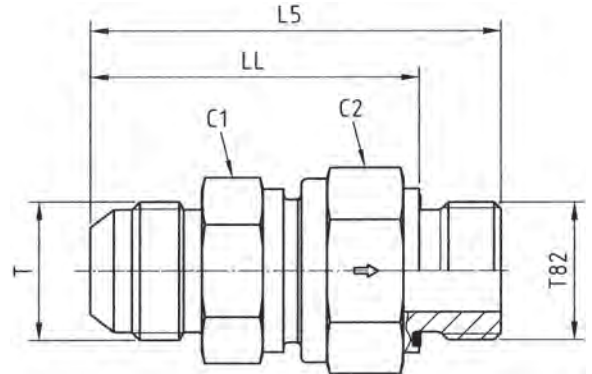

Tube O.D.		Metric thread T82	Thread JIC SAE T	C1	C2	L5	LL	DN (Nom. diam.)	Weight g/1 piece	Order code*	PN (bar) ¹⁾
mm	Inch										CF
6	1/4	M 10×1.0	7/16-20 UNF	19	19	48.0	40.0	3.5	89	4M10RHV82EDMXS	420
8	5/16	M 12×1.5	1/2-20 UNF	22	24	59.5	47.5	5.5	157	5M12RHV82EDMXS	420
10	3/8	M 14×1.5	9/16-18 UNF	24	27	62.0	50.0	7.5	195	6M14RHV82EDMXS	420
12	1/2	M 16×1.5	3/4-16 UNF	27	32	67.0	55.0	9.5	274	8M16RHV82EDMXS	420
14, 15, 16	5/8	M 18×1.5	7/8-14 UNF	32	36	73.5	61.5	11.5	369	10M18RHV82EDMXS	350
18, 20	3/4	M 27×2.0	1 1/16-12 UN	41	46	84.5	68.5	15.0	628	12M27RHV82EDMXS	350
25	1	M 33×2.0	1 5/16-12 UN	46	50	89.5	71.5	19.0	867	16M33RHV82EDMXS	280
28, 30, 32	1 1/4	M 42×2.0	1 5/8-12 UN	60	60	102.0	82.0	24.0	1409	20M42RHV82EDMXS	250
35, 38	1 1/2	M 48×2.0	1 7/8-12 UN	65	70	113.0	91.0	29.0	1970	24M48RHV82EDMXS	210

¹⁾Pressure shown = item deliverable

$$\frac{\text{PN (bar)}}{10} = \text{PN (MPa)}$$

Information on ordering complete fittings or alternative sealing materials see page I7.

*Please add the **suffixes** below according to the material/surface required.

Order code suffixes			
Material	Suffix surface and material	Example	Standard sealing material (no additional suffix needed)
Steel, zinc plated, Cr(VI)-free	CF	4M10RHV82EDMXSCF	NBR

RHZ82EDMXS Non return valve

Triple-Lok® 37° flare end / Male metric thread – ED-seal (ISO 9974)

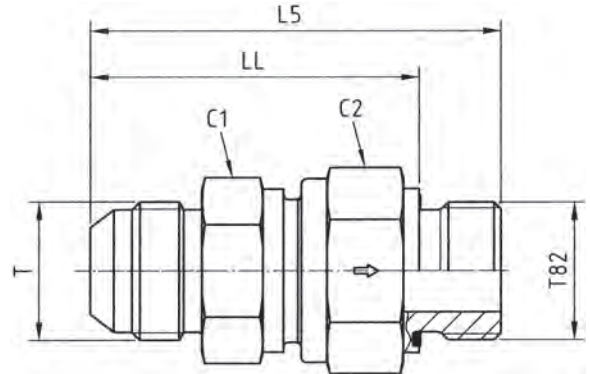

Tube O.D.		Metric thread T82	Thread JIC SAE T	C1	C2	L5	LL	DN (Nom. diam.)	Weight g/1 piece	Order code*	PN (bar) ¹⁾
mm	Inch										CF
6	1/4	M 10×1.0	7/16-20 UNF	19	19	48.0	40.0	3.5	89	4M10RHZ82EDMXS	420
8	5/16	M 12×1.5	1/2-20 UNF	22	24	59.5	47.5	5.5	156	5M12RHZ82EDMXS	420
10	3/8	M 14×1.5	9/16-18 UNF	24	27	62.0	50.0	7.5	195	6M14RHZ82EDMXS	420
12	1/2	M 16×1.5	3/4-16 UNF	27	32	66.0	54.0	9.5	272	8M16RHZ82EDMXS	420
14, 15, 16	5/8	M 18×1.5	7/8-14 UNF	32	36	71.5	59.5	11.5	352	10M18RHZ82EDMXS	350
18, 20	3/4	M 27×2.0	1 1/16-12 UN	41	46	82.5	66.5	15.0	608	12M27RHZ82EDMXS	350
25	1	M 33×2.0	1 5/16-12 UN	46	50	89.5	71.5	19.0	965	16M33RHZ82EDMXS	280
28, 30, 32	1 1/4	M 42×2.0	1 5/8-12 UN	60	60	102.0	82.0	24.0	1396	20M42RHZ82EDMXS	250
35, 38	1 1/2	M 48×2.0	1 7/8-12 UN	65	70	115.0	93.0	29.0	1807	24M48RHZ82EDMXS	210

¹⁾Pressure shown = item deliverable

$$\frac{\text{PN (bar)}}{10} = \text{PN (MPa)}$$

Information on ordering complete fittings or alternative sealing materials see page I7.

*Please add the **suffixes** below according to the material/surface required.

Order code suffixes			
Material	Suffix surface and material	Example	Standard sealing material (no additional suffix needed)
Steel, zinc plated, Cr(VI)-free	CF	4M10RHZ82EDMXSCF	NBR

Ball valves

Technical data ball valves

Leakage rate

0 drops/bubbles per min. (DIN EN 12266 and ISO 5208)

The pressure ratings PN for ball- and shut off- valves include design factor 1.5 for the body and 1.1 for the ball seat (according DIN EN 12266 and ISO 5208).

Steel Ball Valves

Materials:

Body: Steel, Cr(VI)-free plated

Ball: Hardchrome plated carbon steel

Stem: Steel, Cr(VI)-free plated

Seals:

Ball seat: POM

Stem seal: NBR

According to application, different seal combinations are available.

Temperature range:*

-10 up to +100 °C.

Stainless Steel Ball Valves

Materials:

Body: Stainless steel

Ball: Stainless steel

Connectors: Stainless steel

Seals:

Ball seat: POM

Stem seal: NBR

According to application, different seal combinations are available.

Temperature range:

-30 up to +100°C.

(Caution: reduced pressure ratings, see pages P37ff).

Applications:

Suitable for petroleum based hydraulic fluid, lubricants and fuel oil.

Different media and applications on request*

Caution!

Please note the admissible pressure ratings for the tube connection. Ball valves are not suitable for use as flow restriction.

*Remarks:

For clarification of the suitability of the ball valves for different media and applications please provide the following data: system pressure, medium, temperature, possible pressure peaks (including pressure and frequency) and possible operation with full differential pressure.

Certifications and approvals

On demand

3.1 Material certificate (DIN EN 10204)

3.1 Pressure test (DIN EN 10204)

3.2 Certificate (DIN EN 10204)

DNV/GL

ABS

BV

Other certificates on request

Additional components and custom designs

on request

Locking devices (P51)

Levers

Actuators

Limit switches

Ball valves for gas applications

Ball valve combinations

High pressure/High temperature ball valves

Fire safe/ATEX

Custom made special blocks

Material properties

Material of body, connections, ball and stem

	Pressure reduction in % in relation to permitted system temperature in °C													
	-60°	-50°	-40°	-30°	-20°	-10°	0°	+20°	+80°	+100°	+120°	+130°	+150°	+200°
Steel				0%										
Low alloy steel	25%					0%								
Stainless steel	0%									11%				
Duplex			0%							20%				

Sealing material ball seat

	Pressure reduction in % in relation to permitted system temperature in °C													
	-60°	-50°	-40°	-30°	-20°	-10°	0°	+20°	+80°	+100°	+120°	+130°	+150°	+200°
POM			0%											
PEEK natural (unfilled)	see separate table on page P38													
PEEK (graphite filled)			see separate table on page P38											
PTFE	see separate table on page P38													

Sealing material stem and adapter

	Pressure reduction in % in relation to permitted system temperature in °C													
	-60°	-50°	-40°	-30°	-20°	-10°	0°	+20°	+80°	+100°	+120°	+130°	+150°	+200°
NBR				0%										
FKM					0%									
EPDM		0%												
PTFE	see separate table on page P38													

permitted system temperature
 system temperature not permitted

Example

KH18LPEEK/FKM71X	Application temperature: max. 180 °C	Formula:
PN = 420 bar		P _{max} (180°C) = 95bar
Body: 1.4571	Pressure reduction body: 11%	
Ball Seat: PEEK (graphite filled)	Pressure ball seat: 95 bar	
O-ring: FKM	Pressure reduction O-ring: 0%	

PEEK/PTFE Pressure / Temperature Diagram

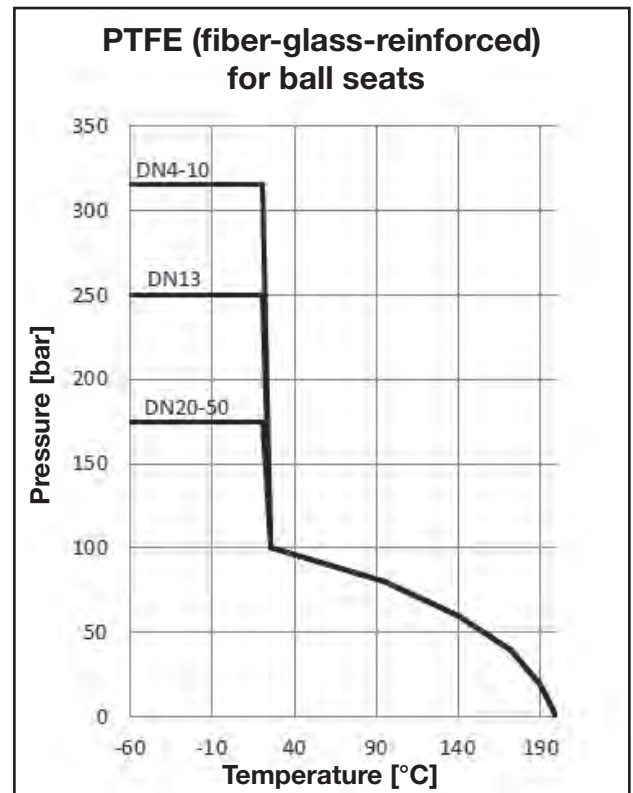
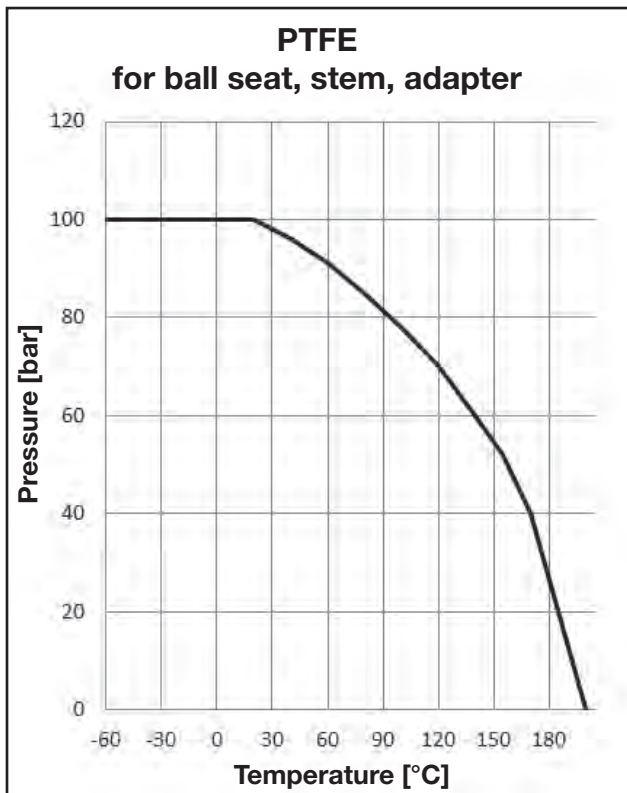
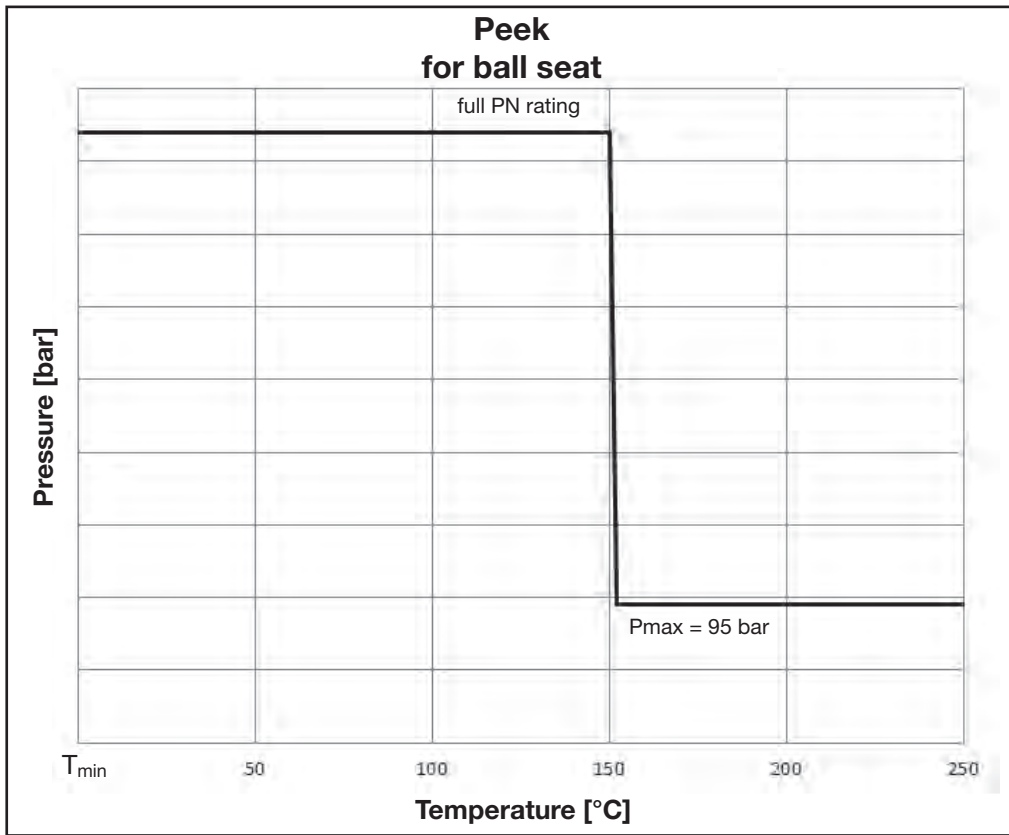

KH 2-way ball valve steel

EO 24° cone end

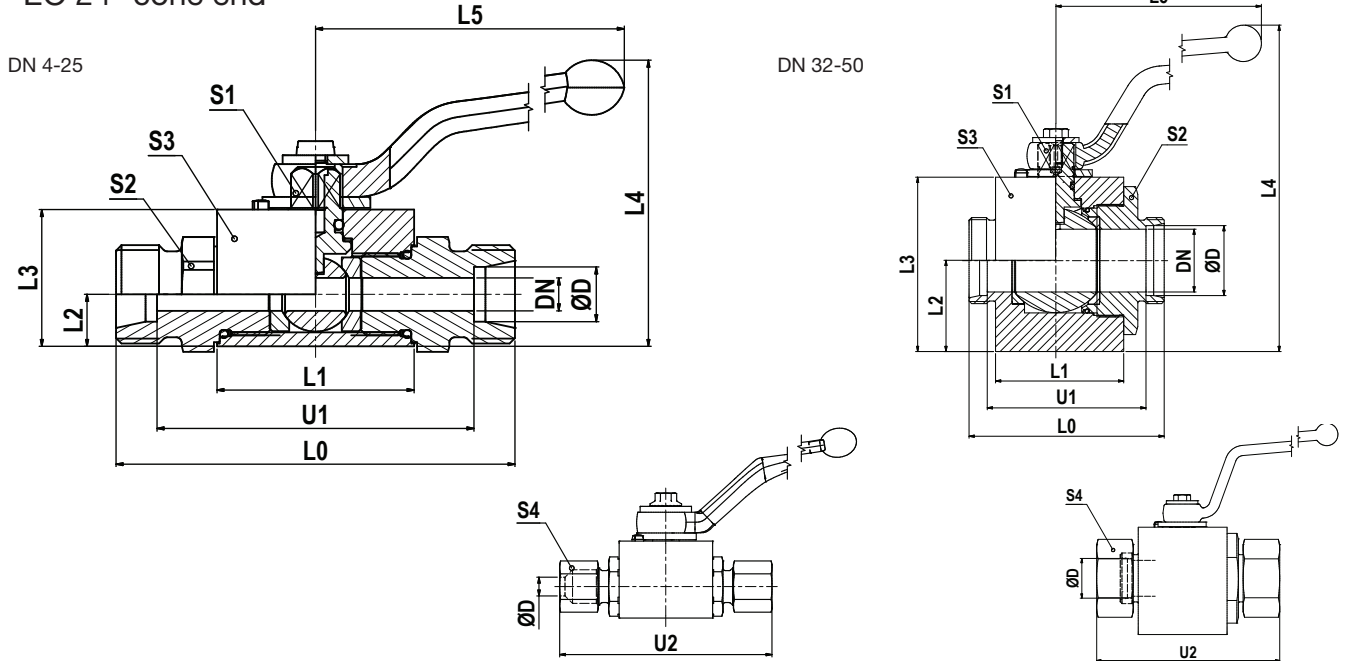

Series	D	DN	L0	L1	L2	L3	L4	L5	U1	U2	S1	S2	S3	S4	Weight g/1 piece	Order code	PN (bar)
L ¹⁾	06	4	67	36.0	9.5	25	54.5	76	53	82	7	19	20	14	195	KH06LCFX	500
	08	6	67	36.0	9.5	25	54.5	76	53	82	7	19	20	17	190	KH08LCFX	500
	10	8	75	45.0	14.5	35	67.5	100	61	90	8	24	30	19	420	KH10LCFX	500
	12	10	75	45.0	14.5	35	67.5	100	61	90	8	24	30	22	410	KH12LCFX	500
	15	13	83	51.0	17.0	40	93.0	113	69	99	10	30	35	27	631	KH15LCFX	500
	18	16	82	50.0	20.0	45	98.0	113	67	99	10	36	45	32	850	KH18LCFX	420
	22	20	99	60.0	24.0	55	120.0	171	84	116	14	41	45	36	1210	KH22LCFX	420
	28	25	108	70.0	26.0	60	125.0	171	93	126	14	50	55	41	1750	KH28LCFX	420
	35	32/25	116	70.0	26.0	60	125.0	171	95	138	14	50	55	50	1820	KH35LDN25CFX	420
	35	32	121	79.0	48.5	94	187.0	228	100	143	17	60	Ø97	50	4888	KH35LCFX	420
	42	40/25	121	70.0	26.0	60	125.0	171	99	144	14	55	55	60	1940	KH42LDN25CFX	420
	42	40	118	77.5	53.5	104	197.0	228	96	141	17	75	Ø107	60	5590	KH42LCFX	420
	S ²⁾	08	5	73	36.0	9.5	25	54.5	76	59	88	7	19	20	19	214	KH08SCFX
10		6	73	36.0	9.5	25	54.5	76	58	90	7	19	20	22	220	KH10SCFX	500
12		8	77	45.0	14.5	35	67.5	100	62	94	8	24	30	24	430	KH12SCFX	500
14		10	81	45.0	14.5	35	67.5	100	65	100	8	24	30	27	440	KH14SCFX	500
16		13	87	51.0	17.0	40	93.0	113	70	106	10	30	35	30	649	KH16SCFX	500
20		16	90	50.0	20.0	45	98.0	113	69	112	10	36	45	36	900	KH20SCFX	420
25		20	107	60.0	24.0	55	120.0	171	83	131	14	41	45	46	1290	KH25SCFX	420
30		25	120	70.0	26.0	60	125.0	171	93	146	14	50	55	50	1880	KH30SCFX	420
38		32/25	134	70.0	26.0	60	125.0	171	102	163	14	55	55	60	1950	KH38SDN25CFX	420
38		32	127	73.0	48.5	94	187.0	228	95	156	17	60	Ø97	60	4740	KH38SCFX	420

¹⁾L = light series; ²⁾S = heavy series

$$\frac{\text{PN (bar)}}{10} = \text{PN (MPa)}$$

Delivery without nut and ring.

Order code suffixes			
Material	Suffix surface and material	Example	Standard sealing material (no additional suffix needed)
Steel, zinc plated, Cr(VI)-free	CF	KH06LCFX	POM / NBR

KH 2-way ball valve stainless steel

EO 24° cone end

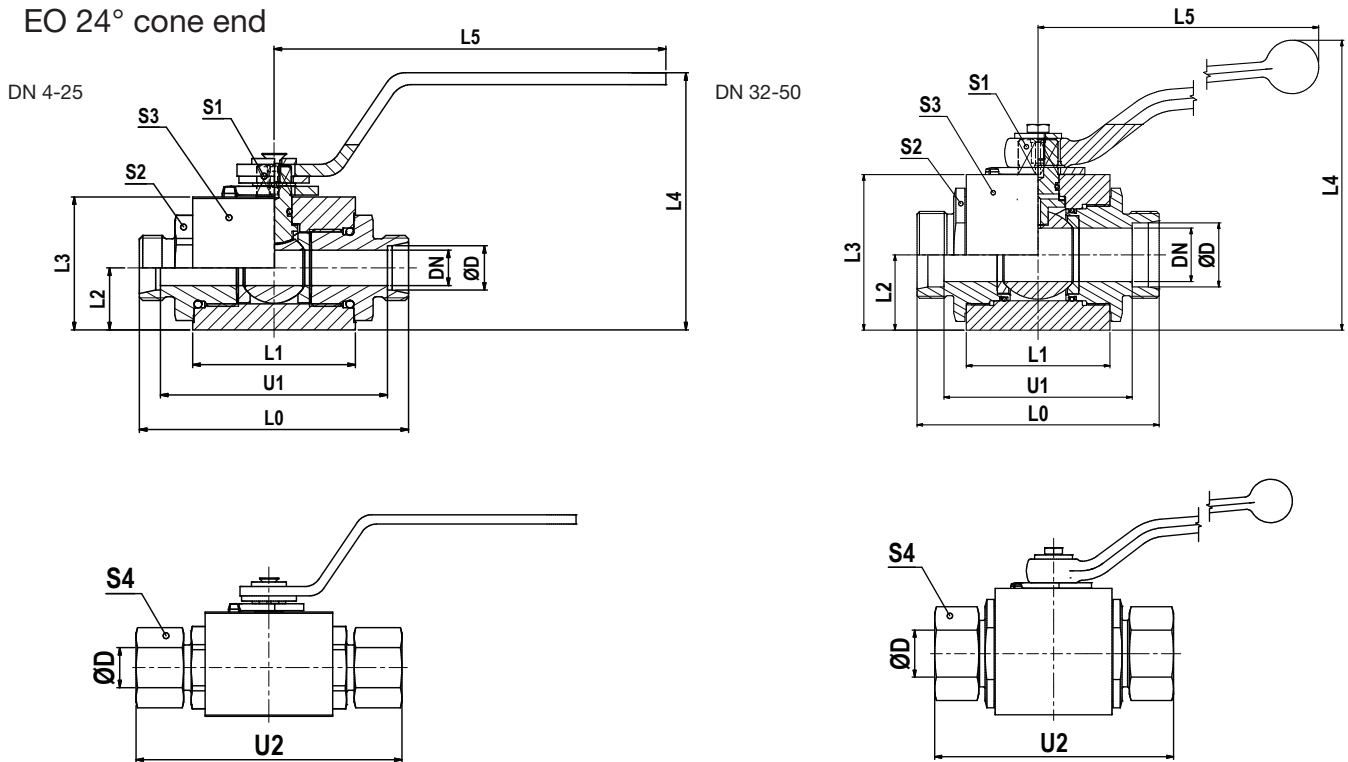

Series	D	DN	L0	L1	L2	L3	L4	L5	U1	U2	S1	S2	S3	S4	Weight g/1 piece	Order code	PN (bar)
L ¹⁾	06	4	73	41.5	13.5	30.0	54	80.0	58.5	88	7	22	30	14	391	KH06L71X	500
	08	6	73	41.5	13.5	30.0	54	80.0	58.5	88	7	22	30	17	392	KH08L71X	500
	10	8	87	53.0	18.0	40.0	82	132.5	73.0	102	8	30	40	19	833	KH10L71X	500
	12	10	87	53.0	18.0	40.0	82	132.5	73.0	102	8	30	40	22	812	KH12L71X	500
	15	12	91	55.0	21.0	45.0	87	132.5	76.5	107	10	32	45	27	1018	KH15L71X	500
	18	12	91	55.0	21.0	45.0	87	132.5	75.5	108	10	32	45	32	1059	KH18L71X	500
	22	20	105	65.0	31.0	65.0	118	190.0	89.5	122	14	46	65	36	2427	KH22L71X	400
	28	25	112	71.0	38.0	75.0	128	190.0	96.5	130	14	50	75	41	3313	KH28L71X	400
	35	32	145	86.0	45.0	93.0	174	320.0	123.5	167	19	70	Ø100	50	6230	KH35L71X	400
	42	40	150	92.0	52.0	104.5	185	320.0	127.5	173	19	80	Ø110	60	7706	KH42L71X	400
S ²⁾	08	4	76	41.5	13.5	30.0	54	80.0	61.5	91	7	22	30	19	390	KH08S71X	500
	10	6	76	41.5	13.5	30.0	54	80.0	60.5	91	7	22	30	22	406	KH10S71X	500
	12	8	89	53.0	18.0	40.0	82	132.5	74.0	106	8	30	40	24	855	KH12S71X	500
	14	10	93	53.0	18.0	40.0	82	132.5	77.0	112	8	30	40	27	850	KH14S71X	500
	16	12	96	55.0	21.0	45.0	87	132.5	78.5	115	10	32	45	30	1050	KH16S71X	500
	20	12	99	55.0	21.0	45.0	87	132.5	77.5	121	10	32	45	36	1090	KH20S71X	500
	25	20	113	65.0	31.0	65.0	118	190.0	88.5	137	14	46	65	46	2490	KH25S71X	400
	30	25	124	71.0	38.0	75.0	128	190.0	96.5	150	14	50	75	50	3430	KH30S71X	400
38	32	145	86.0	45.0	93.0	174	320.0	112.5	174	19	70	Ø100	60	5881	KH38S71X	400	

¹⁾L = light series; ²⁾S = heavy series

$$\frac{PN(\text{bar})}{10} = PN(\text{MPa})$$

Delivery without nut and ring.

Order code suffixes			
Material	Suffix surface and material	Example	Standard sealing material (no additional suffix needed)
Stainless Steel	71	KH06L71X	POM / NBR

KH 2-way BSPP ball valve steel

Female BSPP thread (ISO 1179-1)

DN 4-25

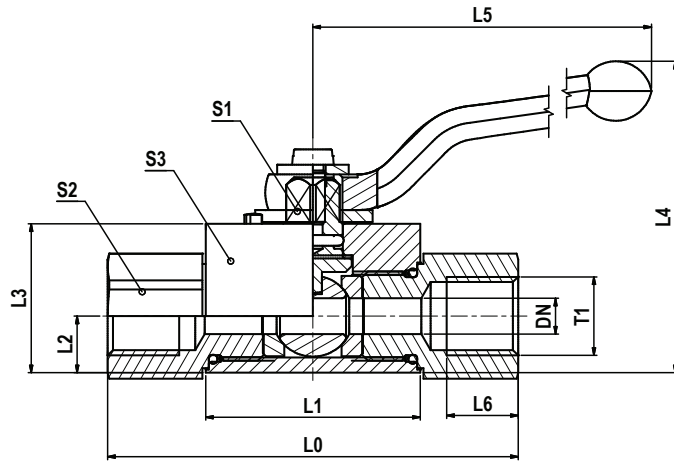

DN 32-50

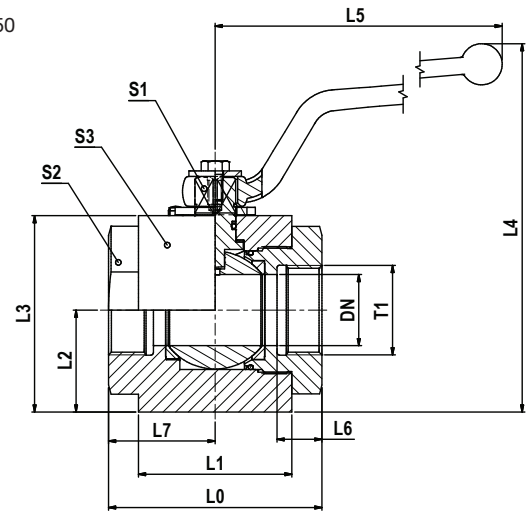

T1	DN	L0	L1	L2	L3	L4	L5	L6	L7	S1	S2	S3	Weight g/1 piece	Order code	PN (bar)
G 1/8	5	69	36	9.5	25.0	54.5	76	12	-	7	19	20	220	KH1/8CFX	500
G 1/4	6	69	36	9.5	25.0	54.5	76	12	-	7	19	20	210	KH1/4CFX	500
G 3/8	10	73	45	14.5	35.0	67.5	100	14	-	8	24	30	430	KH3/8CFX	500
G 1/2	13	82	51	17.0	40.0	93.0	113	15	-	10	30	35	670	KH1/2CFX	500
G 5/8	16	88	50	20.0	45.0	98.0	113	18	-	10	36	45	973	KH5/8CFX	420
G 3/4	20	93	60	24.0	55.0	120.0	171	18	-	14	41	45	1280	KH3/4CFX	420
G 1	25	115	70	26.0	60.0	125.0	171	20	-	14	50	55	1982	KH1CFX	420
G 1 1/4	32	110	80	48.5	94.0	187.0	228	22	55	17	60	Ø97	4888	KH11/4CFX	420
G 1 1/4	32/25	134	70	26.0	60.0	125.0	171	22	-	14	50	55	2066	KH11/4DN25CFX	420
G 1 1/2	40	114	82	53.5	104.0	197.0	228	24	57	17	75	Ø107	6330	KH11/2CFX	420
G 1 1/2	40/25	139	70	26.0	60.0	125.0	171	24	-	14	55	55	2200	KH11/2DN25CFX	420
G 2	50	133	100	61.5	119.5	211.5	306	26	65	17	85	Ø123	9220	KH2CFX	420

$$\frac{\text{PN (bar)}}{10} = \text{PN (MPa)}$$

Order code suffixes			
Material	Suffix surface and material	Example	Standard sealing material (no additional suffix needed)
Steel, zinc plated, Cr(VI)-free	CF	KH1/8CFX	POM / NBR

KH 2-way BSPP ball valve stainless steel

Female BSPP thread (ISO 1179-1)

DN 4-25

DN 32-50

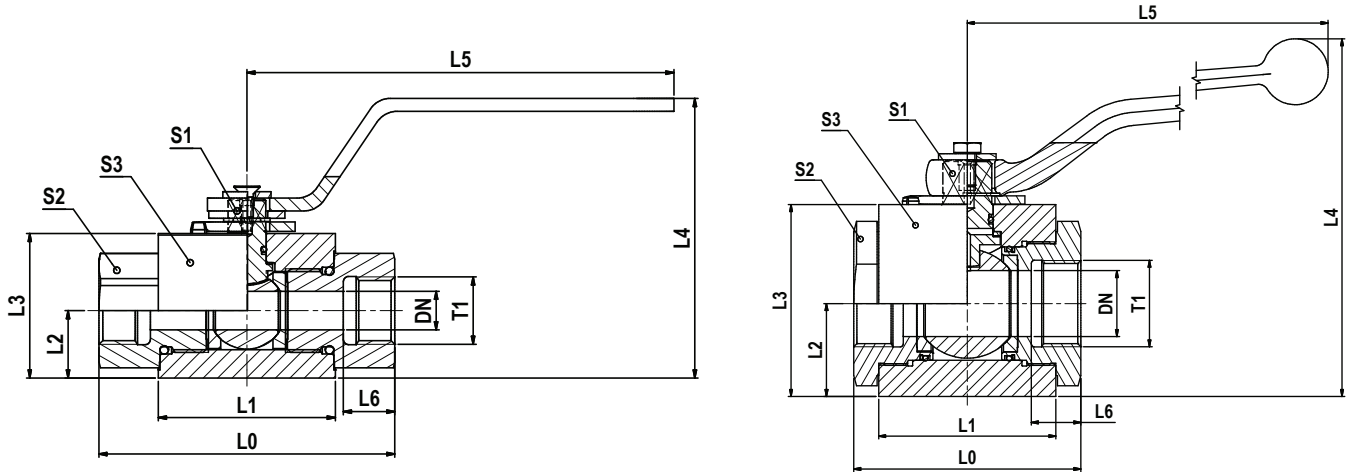

T1	DN	L0	L1	L2	L3	L4	L5	L6	S1	S2	S3	Weight g/1 piece	Order code	PN (bar)
G 1/8	4	69	41.5	13.5	30.0	54	80.0	11.0	7	22	30	420	KH1/871X	500
G 1/4	6	75	41.5	13.5	30.0	54	80.0	14.0	7	22	30	427	KH1/471X	500
G 3/8	10	86	53.0	18.0	40.0	82	132.5	14.0	8	30	40	902	KH3/871X	500
G 1/2	12	92	55.0	21.0	45.0	87	132.5	16.0	10	32	45	1100	KH1/271X	500
G 3/4	20	111	65.0	31.0	65.0	118	190.0	18.0	14	46	65	2699	KH3/471X	400
G 1	25	122	71.0	38.0	75.0	128	190.0	20.0	14	50	75	3620	KH171X	400
G 1 1/4	32	110	86.0	45.0	93.0	174	320.0	24.0	19	70	Ø100	5688	KH11/471X	400
G 1 1/2	40	120	92.0	52.0	104.5	185	320.0	26.0	19	80	Ø110	7379	KH11/271X	400
G 2	50	140	97.0	59.5	119.5	201	320.0	27.5	19	95	Ø125	10086	KH271X	400

$\frac{\text{PN (bar)}}{10} = \text{PN (MPa)}$

Order code suffixes			
Material	Suffix surface and material	Example	Standard sealing material (no additional suffix needed)
Stainless Steel	71	KH1/871X	POM / NBR

KH 2-way NPT ball valve steel

Female NPT thread (SAE 476)

DN 4-25

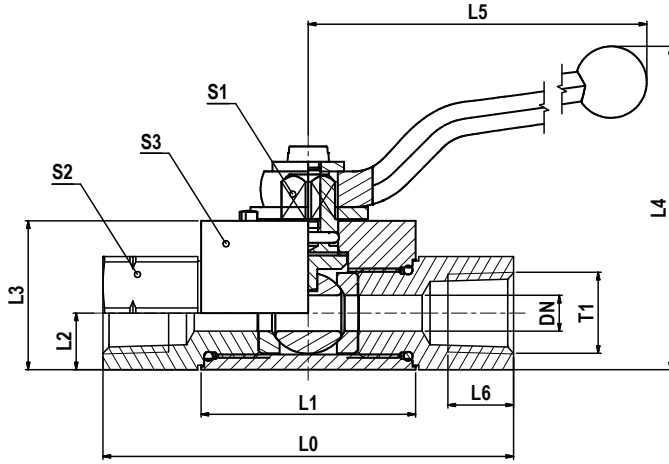

DN 32-50

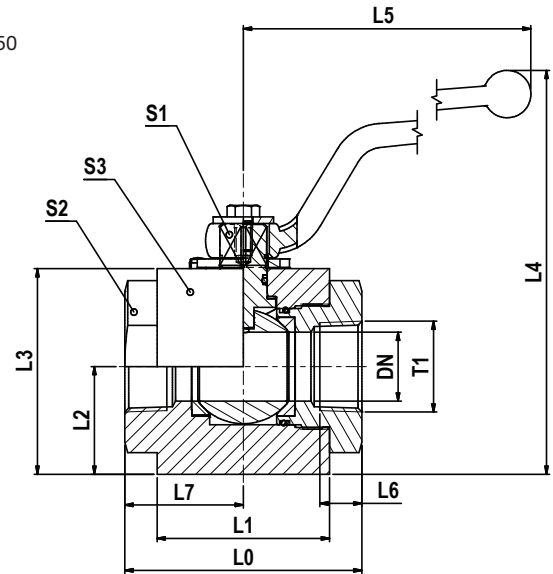

T1	DN	L0	L1	L2	L3	L4	L5	L6	L7	S1	S2	S3	Weight g/1 piece	Order code	PN (bar)
1/8-27 NPT	5	69	36	9.5	25.0	55.0	76	7.0	-	7	19	20	225	KH1/8NPTCFX	500
1/4-18 NPT	6	69	36	9.5	25.0	55.0	76	11.0	-	7	19	20	210	KH1/4NPTCFX	500
3/8-18 NPT	10	73	45	14.5	35.0	68.0	100	11.5	-	8	24	30	430	KH3/8NPTCFX	500
1/2-14 NPT	13	82	51	17.0	40.0	93.0	113	15.0	-	10	30	35	670	KH1/2NPTCFX	500
3/4-14 NPT	20	93	60	24.0	55.0	120.0	171	16.0	-	14	41	45	1300	KH3/4NPTCFX	420
1-11.5 NPT	25	115	70	26.0	60.0	125.0	171	19.0	-	14	50	55	2000	KH1NPTCFX	420
1 1/4-11.5 NPT	32	110	80	48.5	94.0	187.0	228	19.5	55	17	60	Ø97	4888	KH11/4NPTCFX	420
1 1/2-11.5 NPT	40	114	82	53.5	104.0	197.0	228	19.5	57	17	75	Ø107	5590	KH11/2NPTCFX	420
2-11.5 NPT	50	133	100	61.5	119.5	211.5	306	22.0	65	17	85	Ø123	9220	KH2NPTCFX	420

$\frac{PN \text{ (bar)}}{10} = PN \text{ (MPa)}$

Order code suffixes			
Material	Suffix surface and material	Example	Standard sealing material (no additional suffix needed)
Steel, zinc plated, Cr(VI)-free	CF	KH1/8NPTCFX	POM / NBR

KH 2-way NPT ball valve stainless steel

Female NPT thread (SAE 476)

DN 4-25

DN 32-50

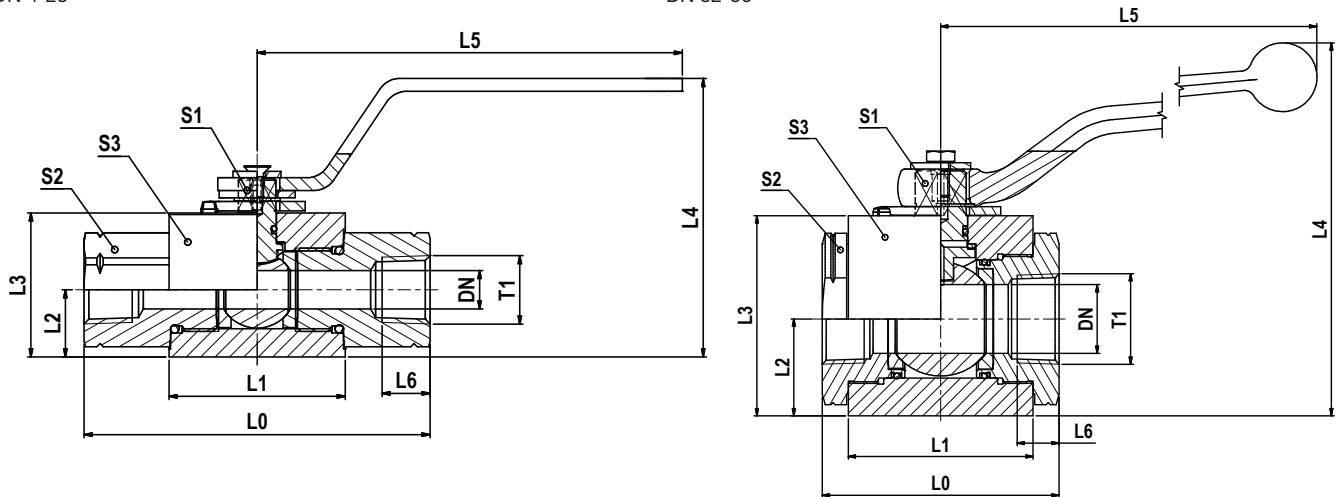

T1	DN	L0	L1	L2	L3	L4	L5	L6	S1	S2	S3	Weight g/1 piece	Order code	PN (bar)
1/8-27 NPT	4	82	41.5	13.5	30.0	54	80.0	8.0	7	22	30	431	KH1/8NPT71X	500
1/4-18 NPT	6	82	41.5	13.5	30.0	54	80.0	11.5	7	22	30	436	KH1/4NPT71X	500
3/8-18 NPT	10	95	53.0	18.0	40.0	82	132.5	11.5	8	30	40	956	KH3/8NPT71X	500
1/2-14 NPT	12	108	55.0	21.0	45.0	87	132.5	15.0	10	32	45	1204	KH1/2NPT71X	500
3/4-14 NPT	20	111	65.0	31.0	65.0	118	190.0	16.0	14	46	65	2723	KH3/4NPT71X	400
1-11.5 NPT	25	122	71.0	38.0	75.0	128	190.0	19.0	14	50	75	3646	KH1NPT71X	400
1 1/4-11.5 NPT	32	110	86.0	45.0	93.0	174	320.0	19.5	19	70	Ø100	5887	KH1/4NPT71X	400
1 1/2-11.5 NPT	40	120	92.0	52.0	104.5	185	320.0	19.5	19	80	Ø110	7430	KH1/2NPT71X	400
2-11.5 NPT	50	140	97.0	59.5	119.5	201	320.0	25.0	19	95	Ø125	10100	KH2NPT71X	400

$\frac{\text{PN (bar)}}{10} = \text{PN (MPa)}$

Order code suffixes			
Material	Suffix surface and material	Example	Standard sealing material (no additional suffix needed)
Stainless steel	71	KH1/8NPT71X	POM / NBR

KH 3-way compact ball valve steel

EO 24° cone end

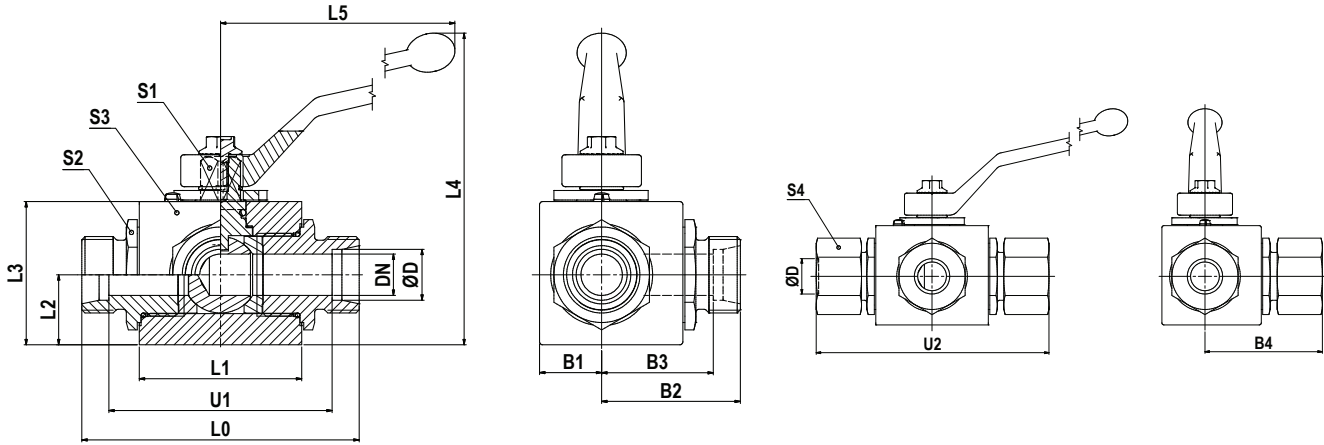

By default 3-way ball valves are manufactured as L-Bore version. Alternative design on request. Pressure inlet only from center port (connector 2).

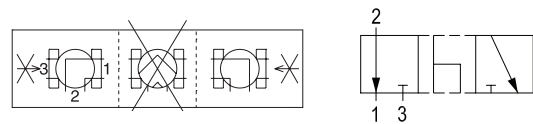

Series	D	DN	L0	L1	L2	L3	L4	L5	U1	U2	B1	B2	B3	B4	S1	S2	S3	S4	Weight g/1 piece	Order code	PN (bar)
L ¹⁾	06	4	67	36	14.5	30	59.5	76	53	82	12.0	33.5	26.5	41.0	7	19	30	14	320	KH3/2-06LCFX	500
	08	6	67	36	14.5	30	59.5	76	53	82	12.0	33.5	26.5	41.0	7	19	30	17	320	KH3/2-08LCFX	500
	10	8	75	45	14.5	35	67.5	100	61	90	17.5	37.5	30.5	45.0	8	24	40	19	550	KH3/2-10LCFX	500
	12	10	75	45	14.5	35	67.5	100	61	90	17.5	37.5	30.5	45.0	8	24	40	22	550	KH3/2-12LCFX	500
	15	13	83	51	22.0	45	98.0	113	69	99	19.5	41.5	34.5	49.5	10	30	45	27	890	KH3/2-15LCFX	500
	18	16	82	50	25.0	50	103.0	113	67	99	25.0	41.0	33.5	49.5	10	36	50	32	1050	KH3/2-18LCFX	400
	22	20	99	60	29.0	60	125.0	171	84	116	23.5	51.0	43.5	58.0	14	41	55	36	1610	KH3/2-22LCFX	400
	28	25	108	70	31.0	65	130.0	171	93	126	30.0	54.0	46.5	63.0	14	50	65	41	2270	KH3/2-28LCFX	400
	35	32/25	116	70	31.0	65	130.0	171	95	138	30.0	58.0	47.5	69.5	14	50	65	50	2480	KH3/2-35LDN25CFX	400
	42	40/25	121	70	31.0	65	130.0	171	99	144	30.0	60.5	49.5	71.5	14	55	65	60	2600	KH3/2-42LDN25CFX	400
S ²⁾	08	5	73	36	14.5	30	54.5	76	59	88	12.0	36.5	29.5	44.0	7	19	30	19	350	KH3/2-08SCFX	500
	10	6	73	36	14.5	30	54.5	76	58	90	12.0	36.5	29.0	45.0	7	19	30	22	350	KH3/2-10SCFX	500
	12	8	77	45	14.5	35	67.5	100	62	94	17.5	38.5	31.0	47.0	8	24	40	24	570	KH3/2-12SCFX	500
	14	10	81	45	14.5	35	67.5	100	65	100	17.5	40.5	32.5	50.0	8	24	40	27	570	KH3/2-14SCFX	500
	16	13	87	51	22.0	45	98.0	113	70	106	19.5	43.5	35.0	53.0	10	30	45	30	910	KH3/2-16SCFX	500
	20	16	90	50	25.0	50	103.0	113	69	112	25.0	45.0	34.5	56.0	10	36	50	36	1120	KH3/2-20SCFX	400
	25	20	107	60	29.0	60	125.0	171	83	131	23.5	55.0	43.0	65.5	14	41	55	46	1720	KH3/2-25SCFX	400
	30	25	120	70	31.0	65	130.0	171	93	146	30.0	60.0	46.5	73.0	14	50	65	50	2440	KH3/2-30SCFX	400
	38	32/25	134	70	31.0	65	130.0	171	102	163	30.0	67.0	51.0	81.5	14	55	65	60	2950	KH3/2-38SDN25CFX	400

¹⁾L = light series; ²⁾S = heavy series

$\frac{PN \text{ (bar)}}{10} = PN \text{ (MPa)}$

Delivery without nut and ring.

Order code suffixes			
Material	Suffix surface and material	Example	Standard sealing material (no additional suffix needed)
Steel, zinc plated, Cr(VI)-free	CF	KH3/2-06LCFX	POM / NBR

KH 3-way compact ball valve stainless steel

EO 24° cone end

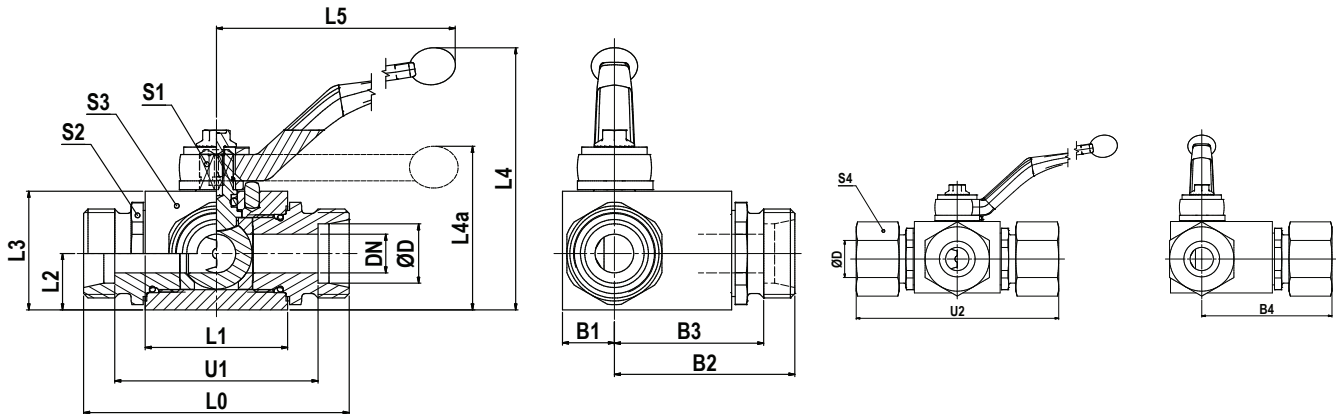

By default 3-way ball valves are manufactured as L-Bore version. Alternative design on request. Pressure inlet only from center port (connector 2).

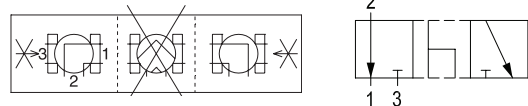

Series	D	DN	L0	L1	L2	L3	L4	L4a	L5	U1	B1	B2	B3	B4	S1	S2	S3	S4	Weight g/1 piece	Order code	PN (bar)
L ¹⁾	06	4	67	40	13.5	33	82		115	53	13.0	50.0	43.0	57.5	9	22	47.5	14	500	KH3/2-06L71X	500
	08	6	67	40	13.5	33	82		115	53	13.0	51.5	44.5	59.5	9	22	47.5	17	520	KH3/2-08L71X	500
	10	8	74	40	13.5	33	82		115	60	13.0	52.5	45.5	60.5	9	22	47.5	19	540	KH3/2-10L71X	500
	12	10	74	43	17.5	38	86		115	60	16.0	55.5	48.5	63.0	9	27	52.0	22	730	KH3/2-12L71X	500
	15	13	82	48	19.0	40	89		115	68	17.5	60.5	53.5	68.5	9	30	57.0	27	850	KH3/2-15L71X	500
	18	16	82	48	19.0	40	89		115	67	17.5	61.5	54.0	70.5	9	30	57.0	32	890	KH3/2-18L71X	500
	22	20	101	62	24.5	57		79	200	86	24.5	71.5	64.0	80.5	14	41	72.0	36	1870	KH3/2-22L71X	315
S ²⁾	28	25	108	66	29.5	65		87	200	93	29.0	81.5	74.0	90.5	14	50	85.5	41	2450	KH3/2-28L71X	315
	35	25	112	66	29.5	65		87	200	91	29.0	85.0	74.5	96.0	14	50	86.0	50	2900	KH3/2-35L71X	315
	08	4	73	40	13.5	33	82		115	59	13.0	56.5	49.5	64.5	9	22	47.5	19	520	KH3/2-08S71X	500
	10	6	73	40	13.5	33	82		115	58	13.0	56.5	49.0	65.5	9	22	47.5	22	540	KH3/2-10S71X	500
	12	8	76	40	13.5	33	82		115	61	13.0	58.5	51.0	67.5	9	22	47.5	24	560	KH3/2-12S71X	500
	14	10	80	43	17.5	38	86		115	64	16.0	62.5	54.5	72.0	9	27	52.0	27	730	KH3/2-14S71X	500
	16	13	86	48	19.0	40	89		115	69	17.5	66.5	58.0	76.5	9	30	57.0	30	860	KH3/2-16S71X	500
	20	13	90	48	19.0	40	89		115	69	17.5	70.5	60.0	81.5	9	32	57.0	36	940	KH3/2-20S71X	500
	25	20	109	62	24.5	57		79	200	85	24.5	82.5	70.5	94.5	14	41	72.0	46	1950	KH3/2-25S71X	315
	30	25	120	66	29.5	65		87	200	93	29.0	93.5	80.0	106.5	14	50	85.5	50	2650	KH3/2-30S71X	315
38	32/25	124	66	29.5	65		87	200	92	29.0	99.0	83.0	114.0	14	55	86.0	60	3100	KH3/2-38SDN2571X	315	

¹⁾L = light series; ²⁾S = heavy series

$\frac{PN \text{ (bar)}}{10} = PN \text{ (MPa)}$

Delivery without nut and ring.

Order code suffixes			
Material	Suffix surface and material	Example	Standard sealing material (no additional suffix needed)
Stainless steel	71	KH3/2-06L71X	POM / NBR

KH 3-way compact BSPP ball valve steel

Female BSPP thread (ISO 1179-1)

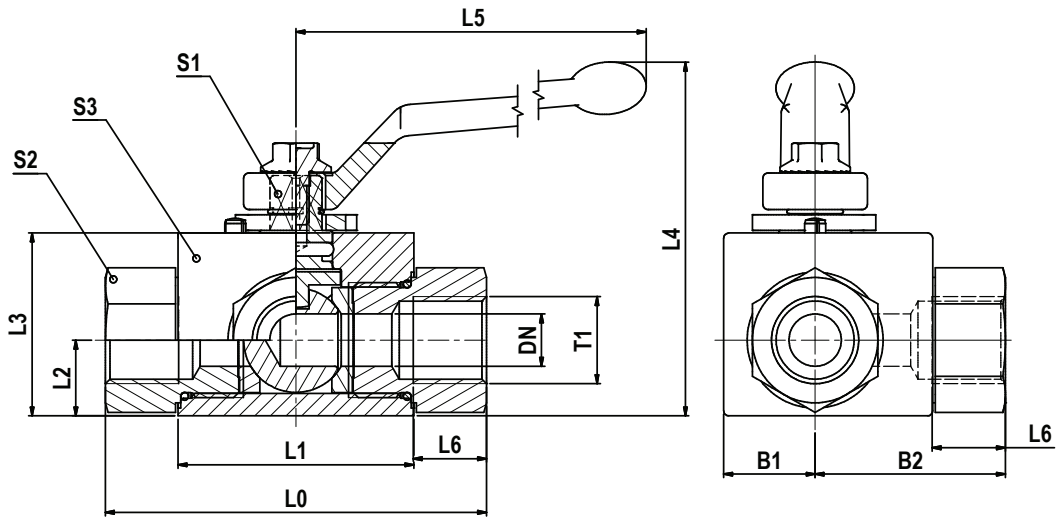

By default 3-way ball valves are manufactured as L-Bore version. Alternative design on request. Pressure inlet only from center port (connector 2).

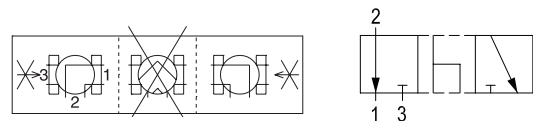

T1	DN	L0	L1	L2	L3	L4	L5	L6	B1	B2	S1	S2	S3	Weight g/1 piece	Order code	PN (bar)
G 1/8	5	69	36	14.5	30	59.5	76	12	12.0	34.5	7	19	30	370	KH3/2-1/8CFX	500
G 1/4	6	69	36	14.5	30	59.5	76	12	12.0	34.5	7	19	30	340	KH3/2-1/4CFX	500
G 3/8	10	73	45	14.5	35	67.5	100	14	17.5	36.5	8	24	40	570	KH3/2-3/8CFX	500
G 1/2	13	82	51	22.0	45	98.0	113	15	19.5	41.0	10	30	45	940	KH3/2-1/2CFX	500
G 5/8	16	88	50	25.0	50	103.0	113	18	25.0	44.0	10	36	50	1240	KH3/2-5/8CFX	400
G 3/4	20	93	60	29.0	60	125.0	171	18	23.5	48.0	14	41	55	1720	KH3/2-3/4CFX	400
G 1	25	115	70	31.0	65	130.0	171	20	30.0	57.5	14	50	65	2650	KH3/2-1CFX	400
G 1 1/4	32/25	134	70	31.0	65	130.0	171	22	30.0	67.0	14	50	65	2710	KH3/2-11/4DN25CFX	400
G 1 1/2	40/25	139	70	31.0	65	130.0	171	24	30.0	69.5	14	55	65	2910	KH3/2-11/2DN25CFX	400

$$\frac{\text{PN (bar)}}{10} = \text{PN (MPa)}$$

Order code suffixes			
Material	Suffix surface and material	Example	Standard sealing material (no additional suffix needed)
Steel, zinc plated, Cr(VI)-free	CF	KH3/2-1/8CFX	POM / NBR

KH 3-way compact BSPP ball valve stainless steel

Female BSPP thread (ISO 1179-1)

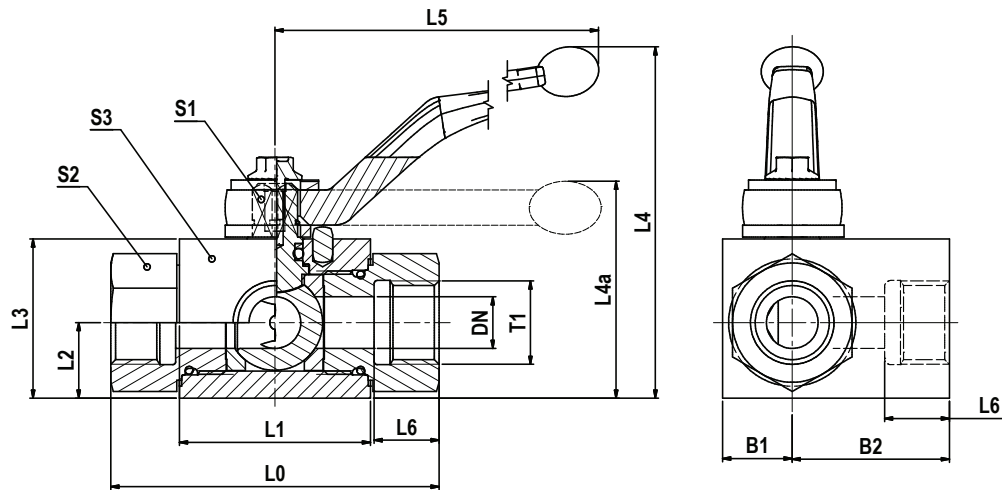

By default 3-way ball valves are manufactured as L-Bore version. Alternative design on request. Pressure inlet only from center port (connector 2).

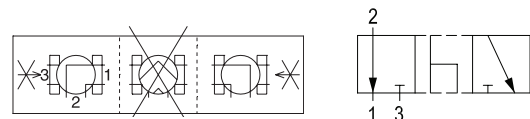

T1	DN	L0	L1	L2	L3	L4	L4a	L5	L6	B1	B2	S1	S2	S3	Weight g/1 piece	Order code	PN (bar)
G 1/8	5	69	40	13.5	33.0	82		115	10.0	13.0	34.5	9	22	47.5	550	KH3/2-1/871X	500
G 1/4	6	69	40	13.5	33.0	82		115	14.0	13.0	34.5	9	22	47.5	550	KH3/2-1/471X	500
G 3/8	10	72	43	17.5	38.0	86		115	14.0	16.0	36.0	9	27	52.0	770	KH3/2-3/871X	500
G 1/2	13	83	48	19.0	40.0	89		115	16.5	17.5	39.5	9	30	57.0	900	KH3/2-1/271X	500
G 3/4	20	95	62	24.5	57.0		79	200	18.0	24.5	47.5	14	41	72.0	1950	KH3/2-3/471X	315
G 1	25	113	66	29.5	65.0		87	200	20.0	29.0	56.5	14	50	85.5	2400	KH3/2-171X	315
G 1 1/4	30	111	81	39.0	84.5		115	320	22.0	39.0	55.0	17	60	94.0	5400	KH3/2-11/471X	350
G 1 1/2	38	130	104	53.0	106.0		136	320	24.0	53.0	65.0	17	75	118.0	9400	KH3/2-11/271X	350
G 2	48	150	118	58.0	116.0		146	320	26.0	58.0	75.0	17	95	133.0	13000	KH3/2-271X	350

$$\frac{\text{PN (bar)}}{10} = \text{PN (MPa)}$$

Order code suffixes			
Material	Suffix surface and material	Example	Standard sealing material (no additional suffix needed)
Stainless steel	71	KH3/2-1/871X	POM / NBR

KH 3-way compact NPT ball valve steel

Female NPT thread (SAE 476)

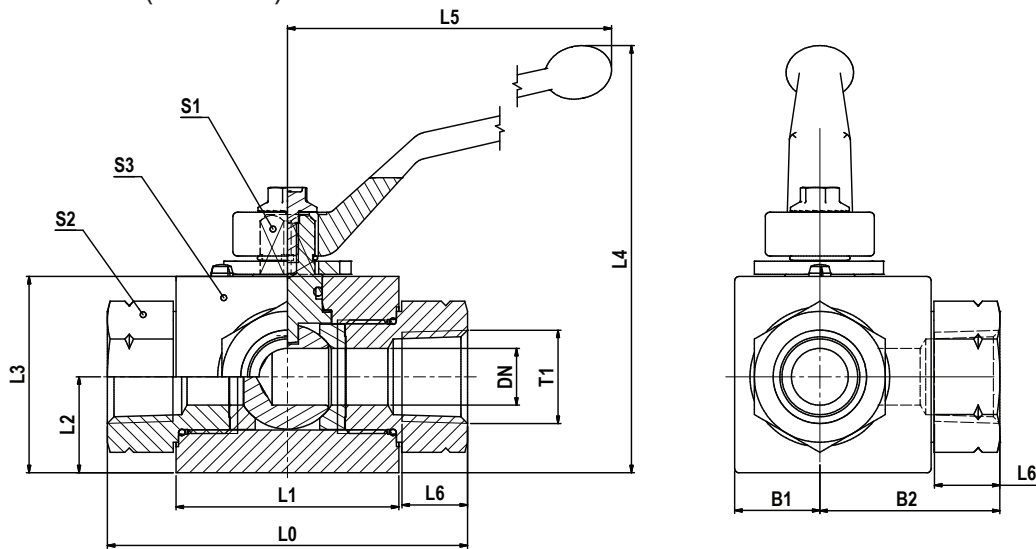

By default 3-way ball valves are manufactured as L-Bore version. Alternative design on request. Pressure inlet only from center port (connector 2).

T1	DN	L0	L1	L2	L3	L4	L5	L6	B1	B2	S1	S2	S3	Weight g/1 piece	Order code	PN (bar)
1/8-27 NPT	5	69	36	14.5	30	59.5	76	7.0	12.0	34.5	7	19	30	370	KH3/2-1/8NPTCFX	500
1/4-18 NPT	6	69	36	14.5	30	59.5	76	10.0	12.0	34.5	7	19	30	340	KH3/2-1/4NPTCFX	500
3/8-18 NPT	10	73	45	14.5	35	67.5	100	11.5	17.5	36.5	8	24	40	570	KH3/2-3/8NPTCFX	500
1/2-14 NPT	13	82	51	22.0	45	98.0	113	15.0	19.5	41.0	10	30	45	940	KH3/2-1/2NPTCFX	500
3/4-14 NPT	20	93	60	29.0	60	125.0	171	16.0	23.5	48.0	14	41	55	1720	KH3/2-3/4NPTCFX	400
1-11.5 NPT	25	115	70	31.0	65	130.0	171	19.0	30.0	57.5	14	50	65	2650	KH3/2-1NPTCFX	400
1 1/4-11.5 NPT	32/25	134	70	31.0	65	130.0	171	19.5	30.0	67.0	14	50	65	2710	KH3/2-11/4NPTDN25CFX	400
1 1/2-11.5 NPT	40/25	139	70	31.0	65	130.0	171	19.5	30.0	69.5	14	55	65	2910	KH3/2-11/2NPTDN25CFX	400

$$\frac{PN \text{ (bar)}}{10} = PN \text{ (MPa)}$$

Also available in stainless steel with different dimensions, e.g. KH3/2-1/8NPT71X

Order code suffixes			
Material	Suffix surface and material	Example	Standard sealing material (no additional suffix needed)
Steel, zinc plated, Cr(VI)-free	CF	KH3/2-1/8NPTCFX	POM / NBR

KH – Locking Devices for Two Way and Multiway ball valves

with floating ball – steel and stainless steel

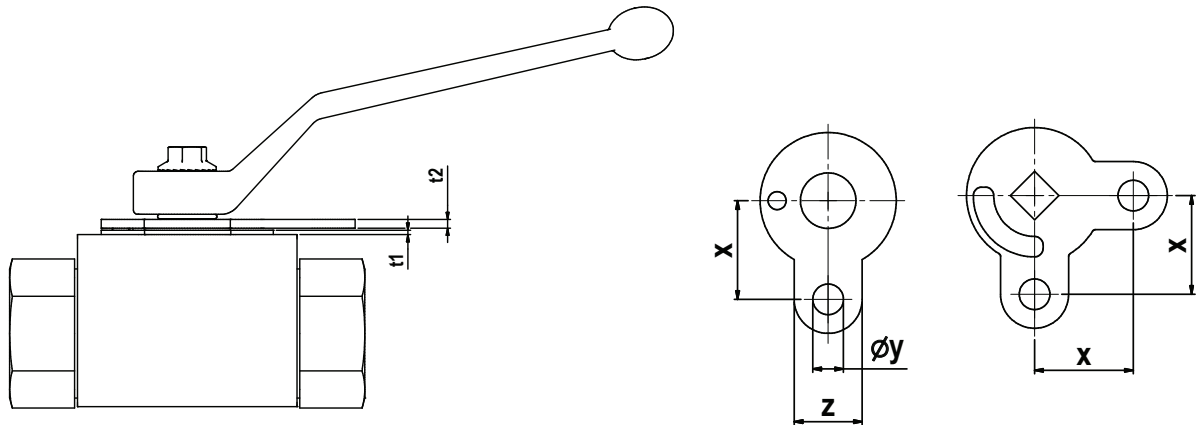

DN	t1	t2	z	y	X	Order code Steel	Order code Stainless steel
4/6	0.5	1.5	20	9	21.5	KHLOCKINGD.SIZE1X	KHLOCKINGD.SIZE171X
8/10	1.0	2.0	20	9	26.5	KHLOCKINGD.SIZE2X	KHLOCKINGD.SIZE271X
12	1.0	2.0	20	9	29.0	KHLOCKINGD.SIZE3X	KHLOCKINGD.SIZE371X
20/25	1.5	2.0	20	9	44.0	KHLOCKINGD.SIZE5X	KHLOCKINGD.SIZE571X
32/40/50	1.5	2.0	20	9	54.0	KHLOCKINGD.SIZE6X	-
32/40/50	1.5	1.5	20	9	54.0	-	KHLOCKINGD.SIZE671X

Disassembly

Assembly

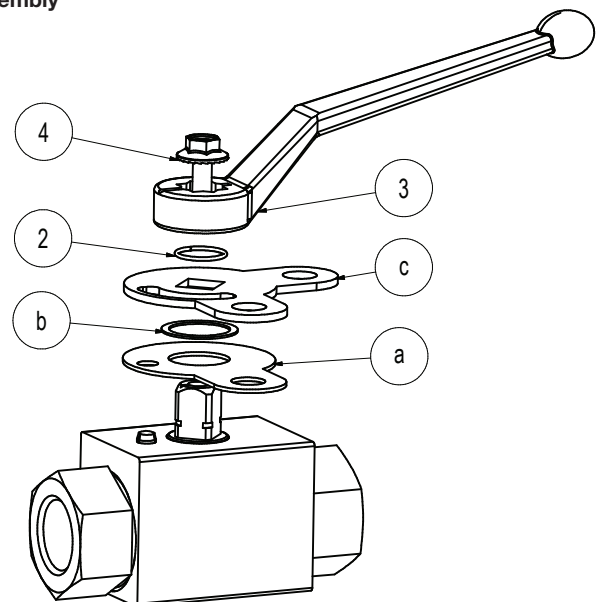
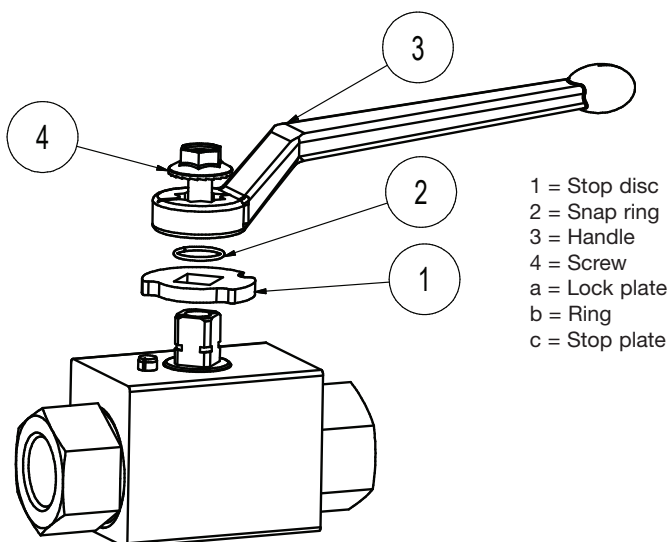

- 1 = Stop disc
- 2 = Snap ring
- 3 = Handle
- 4 = Screw

- a = Lock plate
- b = Ring
- c = Stop plate

*Locking Devices are not suitable for 3/2 Way stainless steel ball valves. Alternative version on request.

KH-B Ball valve - SAE Flange connection (3000/6000 PSI)

SAE Flange connection (ISO 6162-1/-2)

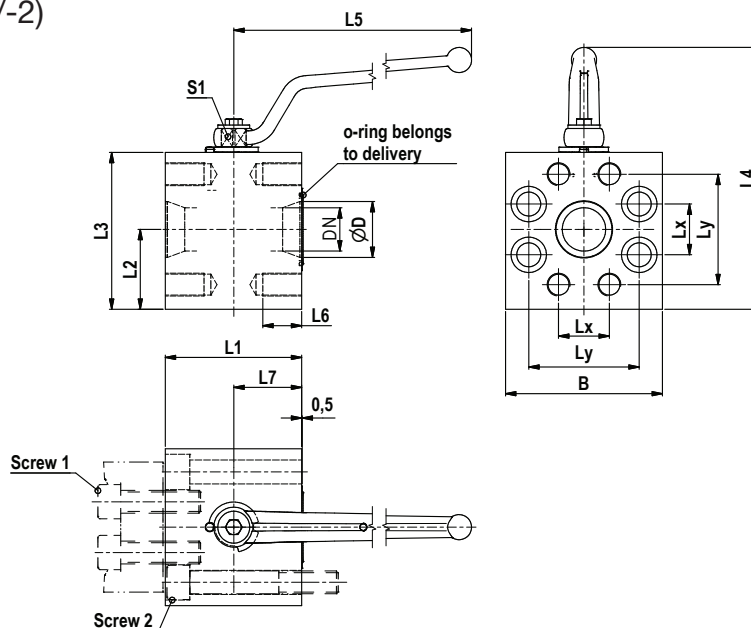

Pressure applications only with connected flanges!
Screws and flanges not included

3000 PSI Series

SAE Inch	DN	D	L1	L2	L3	L4	L5	L6	L7	Lx	Ly	B	S1	M	Screw 1	Screw 2	O-ring	Weight (Steel) kg	Order code Steel	PN (bar)
1/2	13	13	68	30.0	58.0	109	115	15	34.0	17.5	38.1	58.0	9	M08	M8x30-10.9	M8x70-10.9	18.64x3.53	1.57	KH12B1V32CF	350
3/4	20	20	70	37.5	75.0	146	171	17	35.0	22.2	47.6	75.0	14	M10	M10x30-10.9	M10x80-10.9	24.99x3.53	2.76	KH20B1V33CF	350
1	25	25	78	44.0	84.5	155	171	17	39.0	26.2	52.4	84.5	14	M10	M10x30-10.9	M10x80-10.9	32.92x3.53	3.85	KH25B1V34CF	320
1 1/4	25	32	90	50.0	100.0	171	171	21	45.0	30.2	58.7	100.0	14	M10	M10x30-10.9	M10x90-10.9	37.96x3.53	6.35	KH32B1V35CF	280
1 1/2	32	38	99	60.0	120.0	214	306	21	49.5	35.7	69.9	120.0	17	M12	M12x35-10.9	M12x100-10.9	47.22x3.53	10.40	KH40B1V36CF	210
2	38	49	120	70.0	137.5	232	306	21	60.0	42.9	77.8	137.5	17	M12	M12x35-10.9	M12x120-10.9	56.74x3.53	16.00	KH50B1V38CF	210

6000 PSI Series

SAE Inch	DN	D	L1	L2	L3	L4	L5	L6	L7	Lx	Ly	B	S1	M	Screw 1	Screw 2	O-ring	Weight (Steel) kg	Order code Steel	PN (bar)
1/2	13	13	68	30.0	58.0	109	115	15	34.0	18.2	40.5	58.0	9	M08	M8x30-10.9	M8x70-10.9	18.64x3.53	1.57	KH12B1V62CF	420
3/4	20	20	70	37.5	75.0	146	171	17	35.0	23.8	50.8	75.0	14	M10	M10x35-10.9	M10x80-10.9	24.99x3.53	2.73	KH20B1V63CF	420
1	25	25	78	44.0	84.5	155	171	21	39.0	27.8	57.2	84.5	14	M12	M12x45-10.9	M12x80-10.9	32.92x3.53	3.63	KH25B1V64CF	420
1 1/4	25	32	90	50.0	100.0	171	171	20	45.0	31.8	66.7	100.0	14	M12	M12x45-10.9	M12x90-10.9	37.96x3.53	6.25	KH32B1V65CF	420
1 1/2	32	38	99	60.0	120.0	214	306	27	49.5	36.5	79.4	120.0	17	M16	M16x55-10.9	M16x100-10.9	47.22x3.53	9.76	KH40B1V66CF	420
2	38	49	120	70.0	137.5	232	306	34	60.0	44.5	96.8	137.5	17	M20	M20x70-10.9	M20x130-10.9	56.74x3.53	14.74	KH50B1V68CF	420

PN (bar) = PN (MPa)
10

More flange ball valves see catalogue 4162.

Order code suffixes			
Material	Suffix surface and material	Example	Standard sealing material (no additional suffix needed)
Steel, zinc plated, Cr(VI)-free	CF	KH12B1V62CF	POM / NBR
Stainless steel	71	KH12B1V6271	POM / NBR

KH-A Ball valve - SAE Flange adapter connection

SAE Flange adapter (ISO 6162-1/-2)

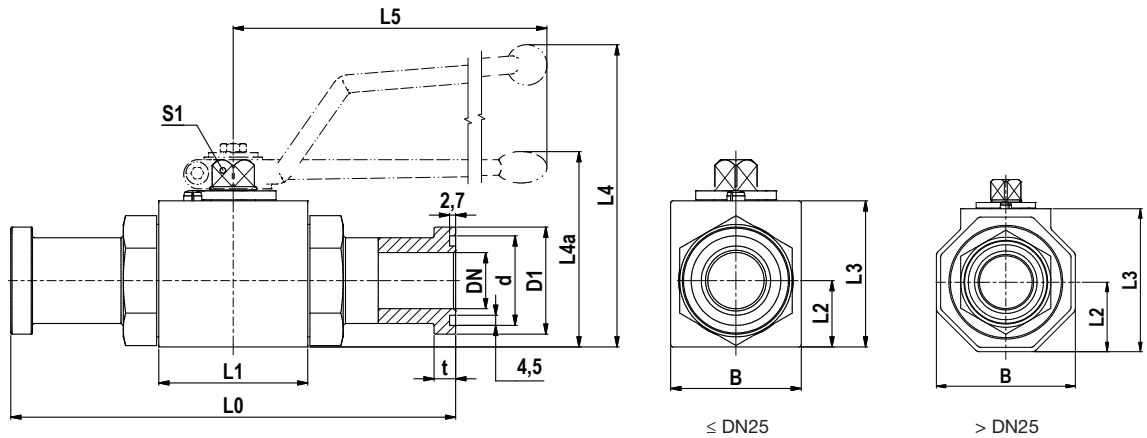

3000 PSI Series

SAE Inch	DN	L0	L1	L2	L3	L4	L4a	L5	B	D1	d	t	S1	Weight (steel)/kg	Order code	PN (bar)
1/2	13	151	48	19.0	40	89		115	35	30.2	25.5	6.8	9	0.85	KH12A32CF	350
3/4	20	162	62	24.5	57		79	200	49	38.1	31.9	6.8	14	1.87	KH20A33CF	350
1	25	178	66	29.5	65		87	200	58	44.4	39.8	8.1	14	2.70	KH25A34CF	315
1 1/4	32	191	80	40.5	86		107	320	81	50.8	44.6	8.1	17	4.22	KH32A35CF	280
1 1/2	38	231	85	50.0	103		124	320	100	60.3	54.1	8.1	17	6.54	KH40A36CF	210
2	48	232	100	59.0	117		138	320	118	71.4	63.6	9.6	17	9.29	KH50A38CF	210

6000 PSI Series

SAE Inch	DN	L0	L1	L2	L3	L4	L4a	L5	B	D1	d	t	S1	Weight (steel)/kg	Order code	PN (bar)
1/2	13	151	48	19.0	40	89		115	35	31.8	25.5	7.9	9	0.90	KH12A62CF	420
3/4	20	174	62	24.5	57		79	200	49	41.3	31.9	8.9	14	1.99	KH20A63CF	420
1	25	206	74	34.5	70		92	200	70	47.6	39.8	9.6	14	3.66	KH25A64CF	420
1 1/4	32	223	80	40.5	86		107	320	81	54.0	44.6	10.4	17	4.72	KH32A65CF	420
1 1/2	40	281	85	50.0	103		124	320	100	63.5	54.1	12.7	17	7.49	KH40A66CF	420
2	48	316	100	59.0	117		138	320	118	79.4	63.6	12.7	17	11.39	KH50A68CF	420

$$\frac{\text{PN (bar)}}{10} = \text{PN (MPa)}$$

Also available in stainless steel with different dimensions, e.g. KH12A3271

Handles are part of the delivery.
O-rings are part of the delivery.

More flange ball valves see catalogue 4162.

Order code suffixes			
Material	Suffix surface and material	Example	Standard sealing material (no additional suffix needed)
Steel, zinc plated, Cr(VI)-free	CF	KH12A62CF	POM / NBR

KH-T Ball valve - SAE Flange connection ISO 6162 (1/2)

SAE Flange connection (ISO 6162-1/-2)

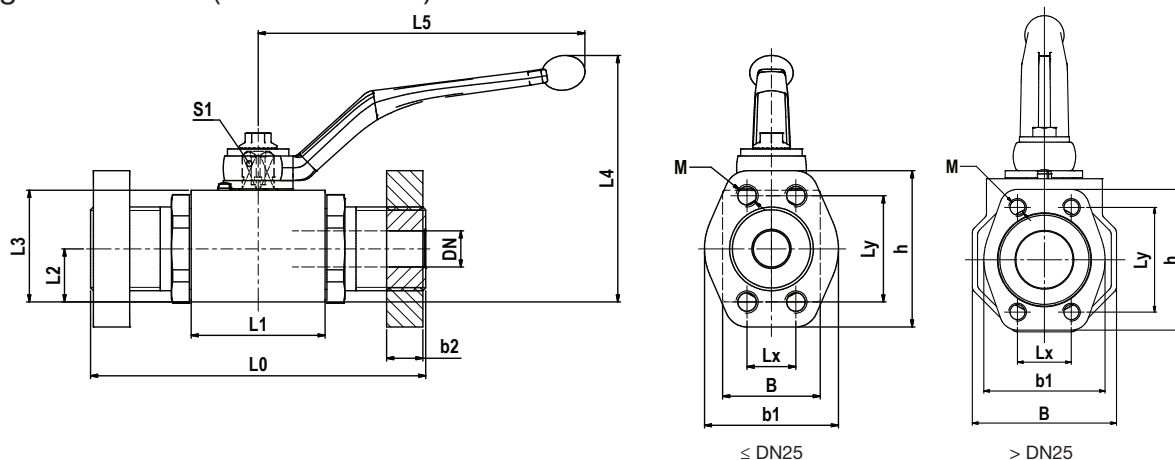

3000 PSI series

SAE Inch	DN	L0	L1	L2	L3	L4	L5	B	Lx	Ly	b1	b2	h	M	S1	O-ring	Weight (Steel) kg	Order code	PN (bar)
1/2	13	120	48	19.0	40	89	115	35	17.5	38.1	48	13	56	M08	9	18.64x3.53	1.5	KH-T-308-13CF	350
3/4	20	136	62	24.5	57	127	171	49	22.2	47.6	50	14	65	M10	14	24.99x3.53	3.0	KH-T-312-20CF	315
1	25	148	66	29.5	65	135	171	58	26.2	52.4	60	16	70	M10	14	32.92x3.53	4.5	KH-T-316-25CF	315
1 1/4	32	172	80	40.5	86	180	306	81	30.2	58.7	68	16	79	M10	17	37.69x3.53	7.5	KH-T-320-32CF	280
1 1/4	32	172	80	40.5	86	180	306	81	30.2	58.7	68	16	79	M12	17	37.69x3.53	7.5	KH-T-320-32TM12CF	210
1 1/2	40	177	85	50.0	103	197	306	100	35.7	69.9	78	16	93	M12	17	47.22x3.53	11.1	KH-T-324-40CF	210
2	50	196	100	59.0	117	211	306	118	42.9	77.8	90	16	102	M12	17	56.74x3.53	19.3	KH-T-332-50CF	210
2 1/2	50/65	196	100	59.0	117	211	306	118	50.8	88.9	105	19	114	M12	17	69.44x3.53	19.9	KH-T-340-50CF	175

6000 PSI series

SAE Inch	DN	L0	L1	L2	L3	L4	L5	B	Lx	Ly	b1	b2	h	M	S1	O-ring	Weight kg	Order code	PN (bar)
1/2	13	120	48	19.0	40	89	115	35	18.2	40.5	48	16	56	M08	9	18.64x3.53	1.6	KH-T-608-13CF	420
3/4	20	136	62	24.5	57	127	171	49	23.8	50.8	60	19	71	M10	14	24.99x3.53	3.3	KH-T-612-20CF	420
1	25	156	74	34.5	70	140	171	70	27.8	57.2	70	24	81	M12	14	32.92x3.53	5.0	KH-T-616-25CF	420
1 1/4	32	172	80	40.5	86	180	306	81	31.8	66.7	78	27	95	M12	17	37.69x3.53	8.5	KH-T-620-32CF	420
1 1/4	32	172	80	40.5	86	180	306	81	31.8	66.7	78	27	95	M14	17	37.69x3.53	8.5	KH-T-620-32TM14CF	420
1 1/2	40	177	85	50.0	103	197	306	100	36.5	79.4	94	30	112	M16	17	47.22x3.53	12.2	KH-T-624-40CF	420
2	50	196	100	59.0	117	211	306	118	44.5	96.8	114	35	134	M20	17	56.74x3.53	21.5	KH-T-632-50CF	420

Also available in stainless steel with different dimensions, e.g. KH-T-308-13SS

More flange ball valves see catalogue 4162.

Order code suffixes			
Material	Suffix surface and material	Example	Standard sealing material (no additional suffix needed)
Steel, zinc plated, Cr(VI)-free	CF	KH-T-308-13CF	POM / NBR

KHBLOCK 2-way manifold ball valve

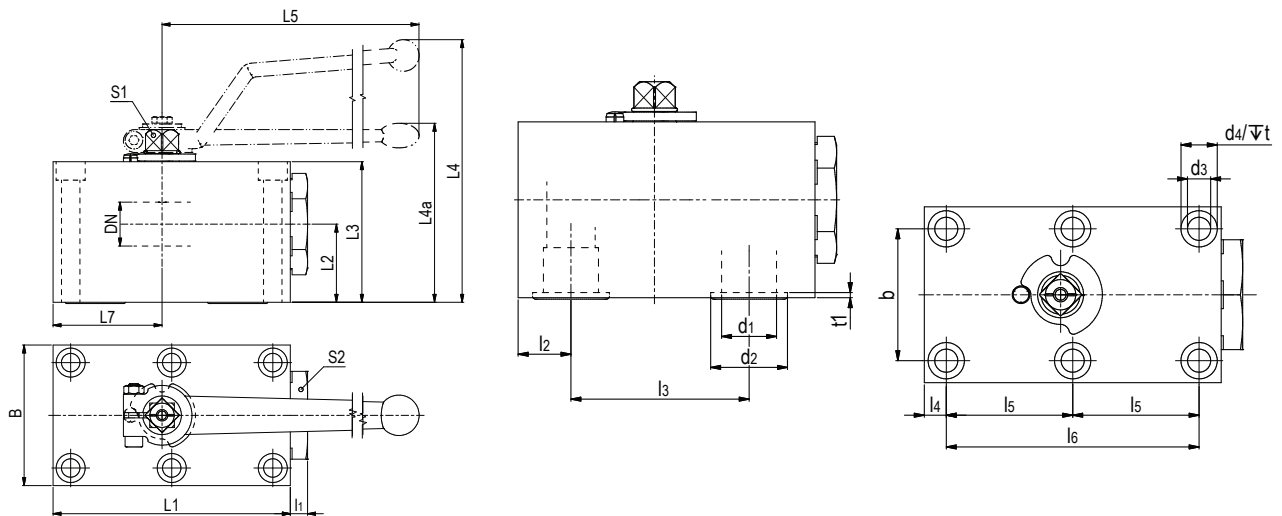

DN	L1	L2	L3	L4	L4a	L5	L7	l1	l2	l3	l4	l5	l6	b	B	d1	d2	d3	d4	t	t1
6	57	19.5	35	67		80	26.0	6	8.5	35	8.5	17.5	35	27	40	6.0	11.8	6.5	10.5	7.0	2.0
10	70	24.5	45	96		115	29.0	10	10.0	44	7.5	27.5	55	40	55	9.5	14.9	8.4	13.5	8.5	2.0
12	98	34.0	55	104		115	42.5	10	16.0	58	7.5	41.5	83	45	60	13.0	24.9	8.4	13.5	7.0	2.0
20	117	37.5	70	on request	92	200	51.0	10	20.0	69	10.0	48.5	97	51	70	20.0	29.0	10.5	16.5	10.5	2.0
25	135	44.5	80		102	200	62.0	10	24.0	81	10.0	57.5	115	60	80	25.0	34.9	10.5	16.5	10.5	2.5
32	165	54.5	100		130	320	75.0	11	29.0	96	12.0	68.0	136	78	100	32.0	40.0	13.0	19.0	12.0	2.0
40	200	57.0	110		140	320	84.5	17	28.5	112	28.5	56.0	112	95	130	38.0	47.7	16.5	25.0	19.0	2.5
50	240	71.0	129		159	320	106.0	15	38.0	136	38.0	68.0	136	112	150	48.0	59.8	21.0	31.0	21.5	2.5

DN	S1	S2	Hexagon Screws	Torque for screws	O-ring	Weight kg	Order code steel	PN (bar)
6	7	19	6x M6x40 - 12.9	14	7x2.5	0.60	KHBLOCKDN6CF	500
10	9	30	6x M8x40 - 12.9	35	10x2.5	1.30	KHBLOCKDN10CF	500
12	9	32	6x M8x60 - 12.9	35	20x2.5	2.30	KHBLOCKDN12CF	420
20	14	46	6x M10x80 - 12.9	70	23.47x2.62	3.92	KHBLOCKDN20CF	420
25	14	50	6x M10x90 - 12.9	70	29x3	5.68	KHBLOCKDN25CF	420
32	17	70	6x M12x110 - 12.9	110	34.59x2.62	11.00	KHBLOCKDN32CF	420
40	17	80	6x M16x120 - 12.9	300	42x3	18.78	KHBLOCKDN40CF	420
50	17	90	6x M20x140 - 12.9	600	54x3	29.70	KHBLOCKDN50CF	420

Tmin/Tmax Steel -20°C / 100°C
 Tmin/Tmax Stainless steel -30°C / 100°C

Handles are part of the delivery.
 O-ring are part of the delivery.
 Screws are not part of the delivery.

Order code suffixes			
Material	Suffix surface and material	Example	Standard sealing material (no additional suffix needed)
Steel, zinc plated, Cr(VI)-free	CF	KHBLOCKDN10CF	POM / NBR
Stainless steel	71	KHBLOCKDN1071	POM / NBR

KHBLOCK 3-way manifold ball valve

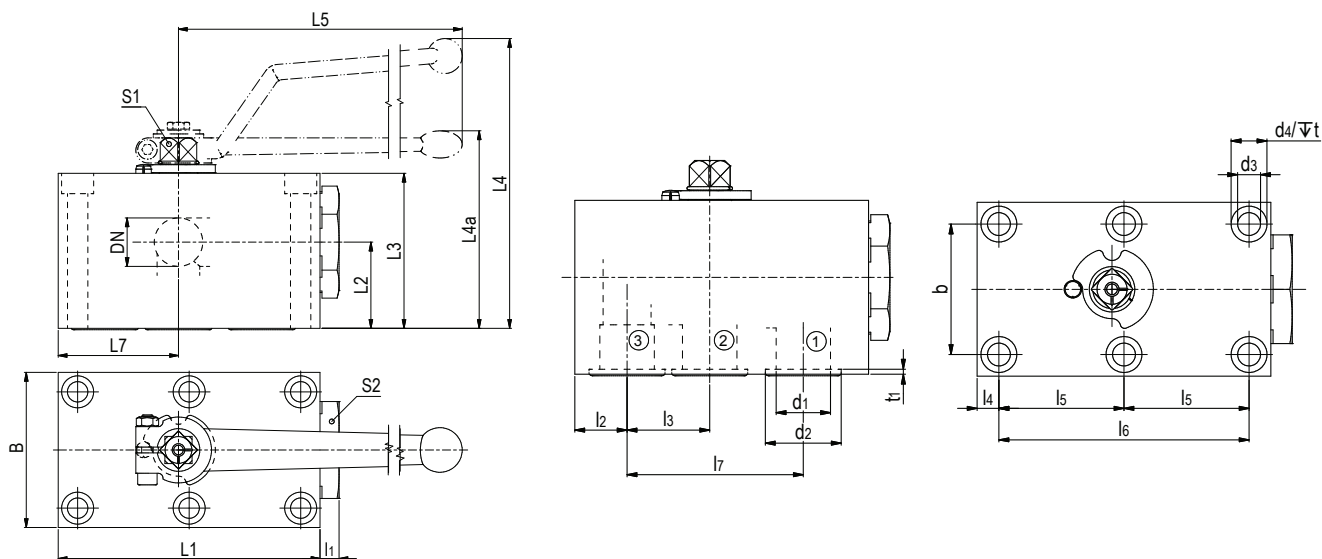

Pressure inlet only from center port (connector 2)

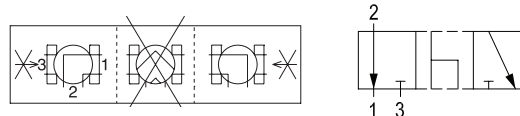

DN	L1	L2	L3	L4	L4*	L5	L7	l1	l2	l3	l4	l5	l6	l7	b	B	d1	d2	d3	d4
6	57	19.5	35	67		80	26.0	6	8.5	17.5	8.5		35	35	27	40	6.0	12.0	6.5	10.5
10	70	24.5	45	93		115	29.0	10	10.0	19.0	7.5		55	44	40	55	9.5	15.0	8.5	13.5
12	98	34.0	55	104		115	42.5	10	16.0	26.5	7.5	41.5	83	58	45	60	13.0	25.0	8.5	13.5
20	117	37.5	70		92	200	51.0	10	20.0	31.0	10.0	48.5	97	69	51	70	20.0	29.0	10.5	16.5
25	135	44.5	80		102	200	62.0	10	24.0	38.0	10.0	57.5	115	81	60	80	25.0	35.0	10.5	16.5
32	165	54.5	100		130	320	75.0	11	29.0	46.0	12.0	68.0	136	96	78	100	32.0	40.0	13.0	19.0
40	200	57.0	110		140	320	84.5	17	28.5	56.0	28.5	56.0	112	112	95	130	38.0	47.5	16.5	25.0
50	240	71.0	129		159	320	106.0	15	38.0	68.0	38.0	68.0	136	136	112	150	48.0	60.0	21.0	31.0

DN	t	t1	S1	S2	Hexagon screws	Torque for screws	O-ring	Weight kg	Order code steel	PN (bar)
6	7.0	2.0	7	19	4x M6x40 - 12.9	14	7x2.5	0.60	KHBLOCK3/2DN6CF	500
10	8.5	2.0	9	30	4x M8x40 - 12.9	35	10x2.5	1.30	KHBLOCK3/2DN10CF	500
12	7.0	2.0	9	32	6x M8x60 - 12.9	35	20x2.5	2.32	KHBLOCK3/2DN12CF	420
20	10.5	2.0	14	46	6x M10x80 - 12.9	70	23.47x2.62	3.90	KHBLOCK3/2DN20CF	420
25	10.5	2.5	14	50	6x M10x90 - 12.9	70	29x3	5.68	KHBLOCK3/2DN25CF	420
32	12.0	2.0	17	70	6x M12x110 - 12.9	110	34.59x2.62	11.00	KHBLOCK3/2DN32CF	420
40	19.0	2.5	17	80	6x M16x120 - 12.9	300	42x3	18.70	KHBLOCK3/2DN40CF	420
50	21.5	2.5	17	90	6x M20x140 - 12.9	600	54x3	28.80	KHBLOCK3/2DN50CF	420

Tmin/Tmax Steel -20°C / 100°C
 Tmin/Tmax Stainless steel -30°C / 100°C

Handles are part of the delivery.
 O-ring are part of the delivery.
 Screws are not part of the delivery.

Order code suffixes			
Material	Suffix surface and material	Example	Standard sealing material (no additional suffix needed)
Steel, zinc plated, Cr(VI)-free	CF	KHBLOCK3/2DN6CF	POM / NBR
Stainless steel	71	KHBLOCK3/2DN671	POM / NBR

Technical data flow control valves

Leakage rate

Flow control valves: Max. 0.01 x DN mm³/sec -
Test medium water (DIN EN 12266)

Check valves: Max. 1.0 x DN mm³/sec - Test medium water
(DIN EN 12266)

Flow control valves can not be used as shut off devices.
Small leakage rates are possible in closed position.

The pressure ratings PN for flow control valves include
design factor 1.5 (according DIN 3230 T5 and ISO 5208).

Steel Flow control valves

Material:

Body: Steel, Cr(VI)-free plated

Seals:

O-ring: NBR

According to application, different seal combinations are
available*

Temperature range:

-20 up to +100 °C.

Cracking pressure:

0.5 bar (optional 4.5 bar)

Stainless Steel Flow control valves

Material:

Body: Stainless steel

Seals:

O-ring: NBR

According to application, different seal combinations are
available.*

Temperature range:

-30 up to +100 °C.

Cracking pressure:

0.5 bar (optional 4.5 bar)

Caution!

Please note the admissible pressure ratings of connec-
tion components!

*Remarks:

For clarification of the suitability of the restriction valves for different media and applications please provide the following data: system pressure, medium, temperature, possible pressure peaks (including pressure and frequency) and possible operation with full differential pressure.

RDV Flow Control Valve

Female BSPP thread (ISO 1179-1)

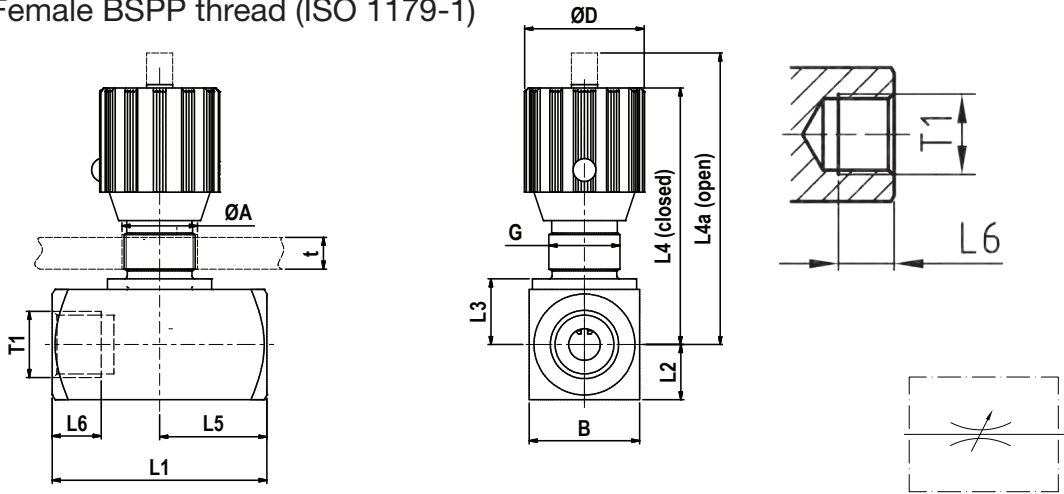

T1	L1	L2	L3	L4	L4a	L5	L6	B	D	A	G	tmax	Order code steel	PN (bar)
G 1/8	38	8.0	10.0	51	56	19	9.0	16	24	13	Pg7	4	RDV1/8CFX	350
G 1/4	48	12.5	14.5	65	71	24	12.0	25	29	19	Pg11	7	RDV1/4CFX	350
G 3/8	58	15.0	17.0	68	75	29	13.5	30	29	19	Pg11	7	RDV3/8CFX	350
G 1/2	68	17.5	21.0	82	92	34	14.5	35	38	23	Pg16	7	RDV1/2CFX	350
G 3/4	78	22.5	26.0	96	106	39	17.5	45	38	23	Pg16	7	RDV3/4CFX	350
G 1	108	25.0	30.0	121	134	54	19.5	50	49	38	Pg29	10	RDV1CFX	350
G 1 1/4	108	30.0	35.0	126	139	54	21.5	60	49	38	Pg29	10	RDV11/4CFX	350
G 1 1/2	108	35.0	40.0	131	144	54	23.5	70	49	38	Pg29	10	RDV11/2CFX	350
G 2	120	45.0	50.0	141	154	60	25.5	90	49	38	Pg29	10	RDV2CFX	350

Flow control valves should not be used as shut-off device.
NPT and UNF connections on request.

Order code suffixes			
Material	Suffix surface and material	Example	Standard sealing material (no additional suffix needed)
Steel, zinc plated, Cr(VI)-free	CF	RDV1/8CFX	POM / NBR
Stainless steel	71	RDV1/871X	POM / NBR

RDVR Flow Control Check Valve

Female BSPP thread (ISO 1179-1)

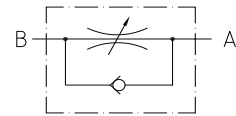
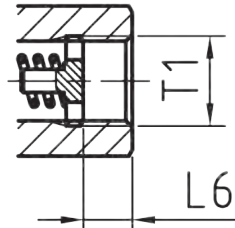
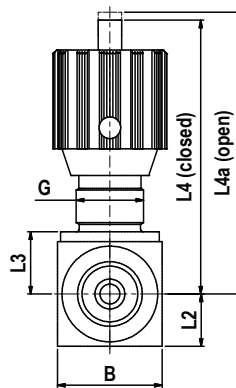
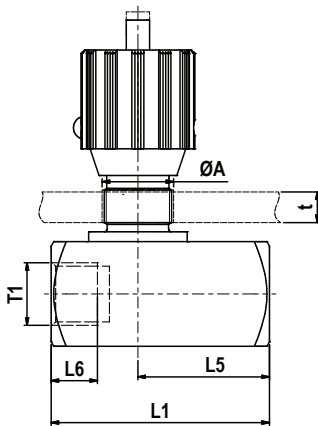

T1	L1	L2	L3	L4	L4a	L5	L6	B	D	A	G	tmax	Order code steel	PN (bar)
G 1/8	45	8.0	10.0	51	56	26.0	9.5	16	24	13	Pg7	4	RDVR1/8CFX	350
G 1/4	55	12.5	14.5	65	71	33.5	13.5	25	29	19	Pg11	7	RDVR1/4CFX	350
G 3/8	65	15.0	17.0	68	75	41.0	13.5	30	29	19	Pg11	7	RDVR3/8CFX	350
G 1/2	73	17.5	21.0	82	92	44.0	15.5	35	38	23	Pg16	7	RDVR1/2CFX	350
G 3/4	88	22.5	26.0	96	106	57.0	17.5	45	38	23	Pg16	7	RDVR3/4CFX	350
G 1	127	25.0	30.0	121	134	77.0	19.5	50	49	38	Pg29	10	RDVR1CFX	350
G 1 1/4	143	30.0	35.0	126	139	93.0	21.5	60	49	38	Pg29	10	RDVR11/4CFX	350
G 1 1/2	143	35.0	40.0	131	144	91.0	23.5	70	49	38	Pg29	10	RDVR11/2CFX	350
G 2	165	45.0	50.0	141	154	111.0	25.5	90	49	38	Pg29	10	RDVR2CFX	350

Flow control valves should not be used as shut-off device.
NPT and UNF connections on request.

Order code suffixes			
Material	Suffix surface and material	Example	Standard sealing material (no additional suffix needed)
Steel, zinc plated, Cr(VI)-free	CF	RDVR1/8CFX	POM / NBR
Stainless steel	71	RDVR1/871X	POM / NBR

Shut off valves

DV Shut-off valve PN 10 – Casing DIN 3512

EO 24° cone end / EO 24° cone end

(with internal threaded spindle)

For cold and warm water* up to 80°C, compressed air, mineral oils and fuel oils types EL and L, 6 bar and up to 80°C.

The pressure specification PN for hand-operated

shut-off valves applies to the design

factor 1,5 (according DIN 3230 T5

and ISO 5208).

Caution!

Please note the admissible pressure ratings for the EO-tube ends.

DVAE

EO tube end ⇒ male BSPP

DVAA

male BSPP ⇐ EO tube end

DV-valves with male BSPP thread on request.

*Indicate type of water or additive if any

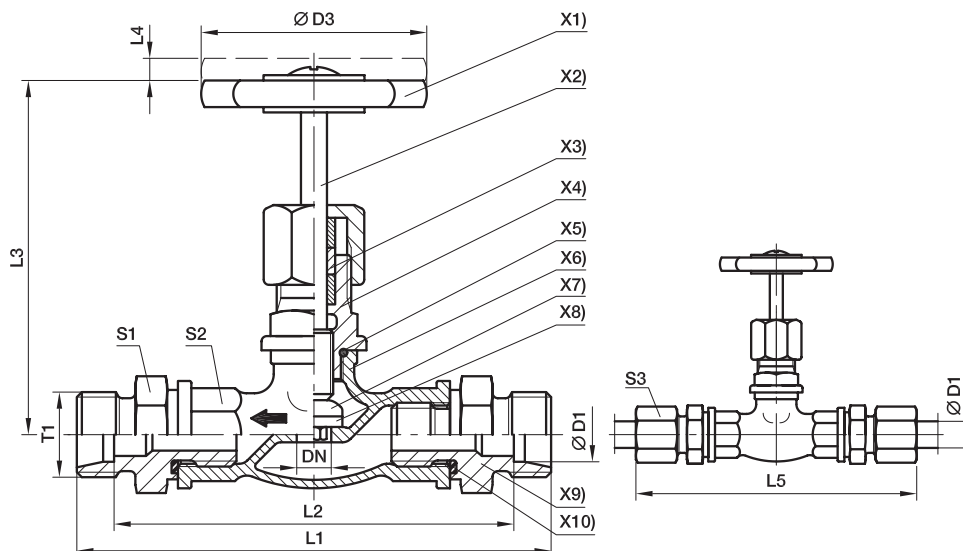

- | | |
|---------------------------------|--------------------------------------|
| X1) Hand wheel: | material: Polyamid |
| X2) Spindle: | material: Brass 2.0401 |
| X3) Stuffing boxpacking: | PTFE Compound |
| X4) Haed piece: | material: Brass 2.0401 |
| X5) Sealing: | O-ring NBR (e. g. Perbunan) |
| X6) Casing: | material: Brass 2.0340.02 |
| X7) Valve cone: | material: Brass 2.0401 |
| X8) Shut-off sealing: | NBR (e.g. Perbunan) |
| X9) Male stud fitting: | material: Brass 2.0540 |
| X10) Sealing: | Eolastic-sealing NBR (e.g. Perbunan) |

Series	D1	T1	DN	D3	L1	L2	L3	L4	L5	S1	S2	S3	Weight g/1 piece	Order code*	PN (bar) ¹⁾ without surface
L ³⁾	06	M 12×1.5	5	50	102	88	63	7	117	22	21	14	313	DV06LX	10
	08	M 14×1.5	6	50	102	88	63	7	117	22	21	17	305	DV08LX	10
	10	M 16×1.5	8	50	104	90	63	7	119	22	21	19	308	DV10LX	10
	12	M 18×1.5	10	50	104	90	63	7	119	22	21	22	304	DV12LX	10
	15	M 22×1.5	12	50	107	93	65	8	123	27	25	27	426	DV15LX	10
	18	M 26×1.5	16	50	109	94	67	8	126	27	25	32	434	DV18LX	10
	22	M 30×2.0	20	60	123	108	67	8	140	32	32	36	670	DV22LX	10
	28	M 36×2.0	25	60	140	125	95	10	158	41	38	41	1030	DV28LX	10
	35	M 45×2.0	32	70	166	145	102	10	188	50	47	50	1640	DV35LX	10

¹⁾Pressure shown = item deliverable

³⁾L = light series

$$\frac{\text{PN (bar)}}{10} = \text{PN (MPa)}$$

Delivery without nut and ring. Information on ordering complete fittings or alternative sealing materials see page 17.

*Please add the **suffixes** below according to the material/surface required.

Order code suffixes			
Material	Suffix surface and material	Example	Standard sealing material (no additional suffix needed)
Brass 2.0340.02	without	DV06LX	PTFE / NBR

LD Shut-off valve PN 40

EO 24° cone end / EO 24° cone end

(with internal threaded spindle)

For hydraulic oil, mineral, oil, fuel oil, Diesel, water* etc. Temperature up to 150°C. For steam up to 10 bar.
For compressed air up to 35 bar on request. CS DIN 86501 Rg.-N.

The pressure specification PN for hand-operated shut-off valves applies to the design factor 1,5 (according DIN 3230 T5 and ISO 5208).

Caution!

Please note the admissible pressure ratings for the EO-tube ends.

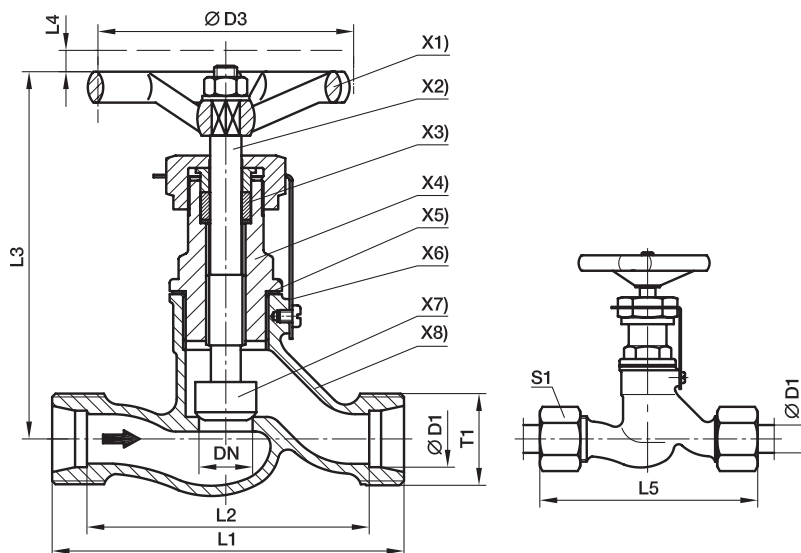

- X1) **Hand wheel:** Plastic material typ 74 according to DIN 388 Form C
- X2) **Spindle:** with internal thread. Material: Cu Zn 35 Ni 2
- X3) **Stuffing box packing:** Graphite
- X4) **Head piece:** material: Cu Zn 39 Pb 3
- X5) **Sealing:** Copper ring
- X6) **Locking plates:** material: St. 37/zinc plated
- X7) **Valve cone:** loose tip material: Cu Zn 35 Ni 2
- X8) **Casing:** material: G-Cu Sn 5Zn Pb (Rg 5 according to DIN 1705)

EO-tube connection:

for **copper** tubes nuts, cutting and locking rings of brass

Attention:

for **steel** tubes: nuts, progressive rings of steel **specify when ordering**

We recommend pre-installation in hardened pre-installation body (see assembly instructions)

Series	D1	T1	DN	D3	L1	L2	L3	L4	L5	S1	Weight g/1 piece	Order code*	PN (bar) ¹⁾ without surface
S ⁴⁾	10	M 18×1.5	6	63	60	45	98	7	77	22	383	LD10SX	40
	12	M 20×1.5	8	63	64	49	98	7	81	24	401	LD12SX	40
	14	M 22×1.5	10	63	70	54	98	7	89	27	417	LD14SX	40
	16	M 24×1.5	12	80	84	67	110	9	103	30	631	LD16SX	40
	20	M 30×2.0	16	80	90	69	110	9	112	36	688	LD20SX	40
	25	M 36×2.0	20	100	110	86	129	12	134	46	1191	LD25SX	40
	30	M 42×2.0	25	100	120	93	129	12	146	50	1322	LD30SX	40
	38	M 52×2.0	32	100	140	108	158	12	169	60	2268	LD38SX	40

¹⁾Pressure shown = item deliverable

⁴⁾S = heavy series

$$\frac{\text{PN (bar)}}{10} = \text{PN (MPa)}$$

Delivery without nut and ring. Information on ordering complete fittings or alternative sealing materials see page I7.

*Please add the **suffixes** below according to the material/surface required.

Order code suffixes			
Material	Suffix surface and material	Example	Standard sealing material (no additional suffix needed)
Gunmetal (Rg 5) 2.1096	without	LD10SX	Graphit / Metal

VDHA High pressure valve

EO tube end / EO tube end

with internal threaded spindle and body of low grade forged stainless steel
 The pressure specification PN for hand-operated shut-off valves applies to the design factor 1,5 (according DIN 3230 T5 and ISO 5208).

Caution!
 Please note the admissible pressure ratings for the EO-tube ends.

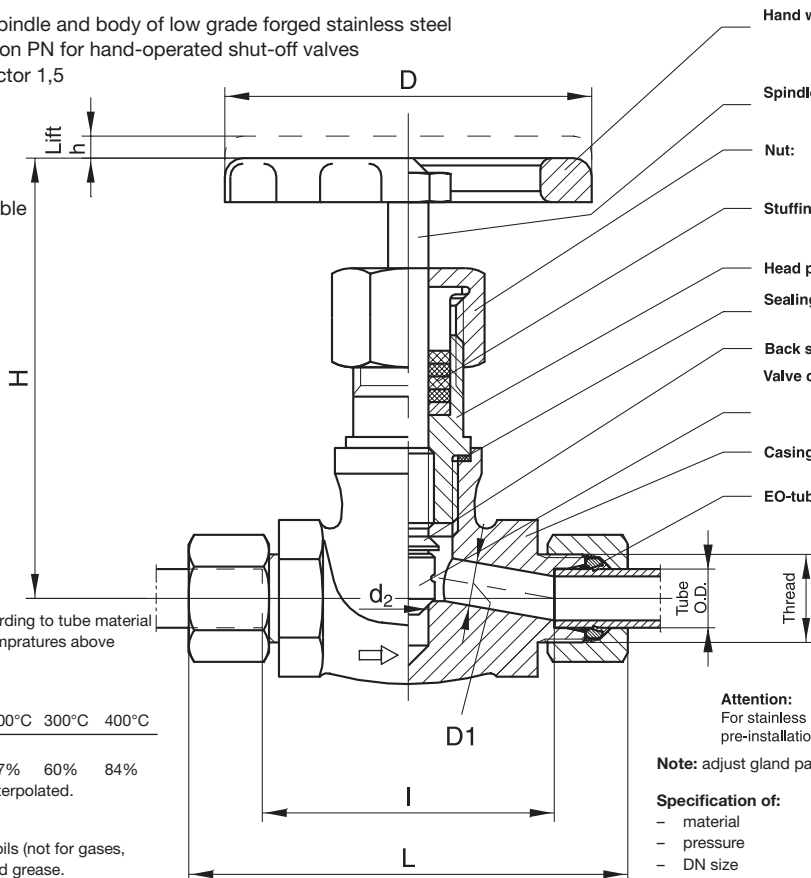

- Hand wheel:** Aluminium die casting GD-AL Si 8 Cu 3
Operating position: completely opened or closed.
- Spindle:** with internal thread. Material 1.4021
- Nut:** Material 1.0718
- Stuffing box packing:** GA 24 (Graphit)
- Head piece:** Material 1.0460
- Sealing:** between casing and head piece, material-no. 2.4066
- Back sealing:** against head piece
- Valve cone:** hardened loose tip material 1.4122. For VDHA 30-PS and 38-PS material 1.0460 forged with Cr 17
- Casing:** forged. Material No. 1.4104
- EO-tube connection:** Nuts and progressive rings of steel for the assembly of steel tubes. For stainless steel tubes material no. 1.4571 or 1.4541 and temperatures above 120°C progressive rings and nuts of 1.4571 are to used. (Please specify when ordering)

Temperatures up to 400°C according to tube material (consider pressure drop with temperatures above 50°C)

Required pressure reductions

temperature	50°C	100°C	200°C	300°C	400°C
pressure reductions	6%	15%	37%	60%	84%

Intermediate values are to be interpolated.

Applications:
 For water, steam, hot and cold oils (not for gases, oxygen etc.) on mineral oil based grease.
 For compressed air up to 50°C. For corrosive media, acids, fire resistant fluid etc.

Attention:
 For stainless steel tubes always pre-assembly in hardened pre-installation body (see assembly instructions)

Note: adjust gland packing prior to initial working period.

- Specification of:**
- material
 - pressure
 - DN size
 - identification mark on hand wheel.

Series	D1	PN (bar)	DN	Thread	d2	H	L	I	h	D	Weight g/1 piece	With Nut and Ring	
												Dry Technology EO-2	PSR steel
S ⁴⁾	06	630	4	M 14×1.5	9.5	120	95	66	6	100	891	VDHA06ZS	VDHA06S
	08	630	5	M 16×1.5	9.5	120	95	66	6	100	917	VDHA08ZS	VDHA08S
	10	630	7	M 18×1.5	9.5	120	97	65	6	100	937	VDHA10ZS	VDHA10S
	12	630	8	M 20×1.5	9.5	120	97	65	6	100	940	VDHA12ZS	VDHA12S
	14	630	10	M 22×1.5	9.5	120	119	84	6	100	1194	VDHA14ZS	VDHA14S
	16	400	11	M 24×1.5	9.5	120	119	83	6	100	1209	VDHA16ZS	VDHA16S
	20	400	13	M 30×2.0	11.0	120	122	79	6	100	1292	VDHA20ZS	VDHA20S
	25	400	17	M 36×2.0	12.0	143	154	106	9	125	2013	VDHA25ZS	VDHA25S
	30	250	19	M 42×2.0	22.5	164	156	103	12	125	2596	VDHA30ZS	VDHA30S
	38	250	25	M 52×2.0	26.5	198	179	118	12	180	4972	VDHA38ZS	VDHA38S

¹⁾ Pressure shown = item deliverable

⁴⁾ S = heavy series

$$\frac{PN \text{ (bar)}}{10} = PN \text{ (MPa)}$$

WV Alternating valve

EO 24° cone end / EO 24° cone end / EQ 24° cone end

These valves permit the passage of flow from either inlet 1 or 2 to the outlet port whilst shutting of the inlet port not in use. The shutting off, of an inlet is achieved by a floating ball bearing which moves by the pressure of the flow.

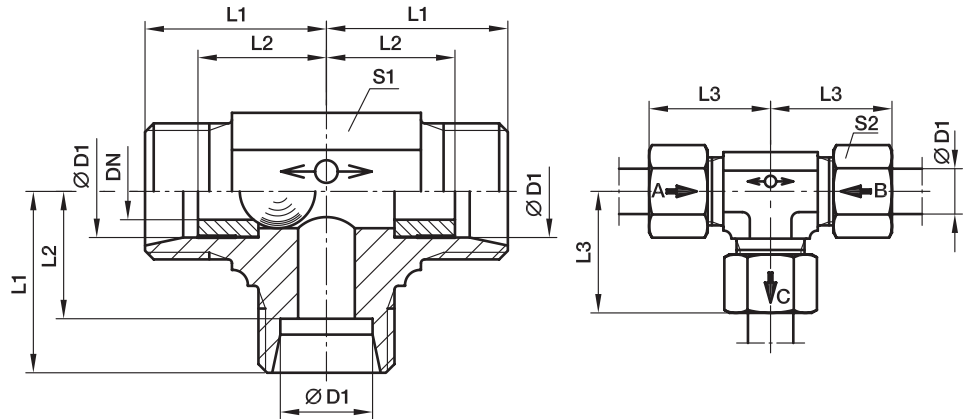

Material: steel
Surface finish: Cr(VI)-free.

Valves are not recommended for compressed air and gases.
WV-valves are not to be used in connection with weld nipples, swivel nuts etc. where there is no contact with a shoulder stop in the inner cone.

Temperature range without pressure reductions: -40°C up to +120°C.

Recommended fitting position as shown in the picture.

Leakage rate for alternating valves hydraulic test with test pressure = P_{max} : approx. 20 drops (test period of 1 minute).

Directions of flow:

$D_1 \rightarrow D_3 = D_2$ closed
 $D_2 \rightarrow D_3 = D_1$ closed

Series	D1	T1	DN	L1	L2	L3	S1	S2	Weight g/1 piece	Order code*	PN (bar) ¹⁾ CF
L ³⁾	8	M 14x1.5	4.5	21	14	29	14	17	53	WV08LOMD	160
	10	M 16x1.5	6.0	22	15	30	17	19	73	WV10LOMD	160
	12	M 18x1.5	7.5	24	17	32	19	22	96	WV12LOMD	160
	15	M 22x1.5	10.0	28	21	36	19	27	134	WV15LOMD	160

¹⁾Pressure shown = item deliverable

³⁾L = light series

$\frac{PN \text{ (bar)}}{10} = PN \text{ (MPa)}$

Delivery without nut and ring. Information on ordering complete fittings or alternative sealing materials see page I7.

*Please add the **suffixes** below according to the material/surface required.

Order code suffixes			
Material	Suffix surface and material	Example	Standard sealing material (no additional suffix needed)
Steel, zinc plated, Cr(VI)-free	CF	WV08LOMDCF	Steel ball

ELA air-bleed valves

Hydraulic systems can effectively be bled with ELA air-bleed valves.

Easily installed – maintenance-free – almost unlimited service life – simple – safe – reliable – efficient.
The system can be operated immediately. No control irregularities due to air contamination of the pressure medium.
Cost saving, as non-productive de-aeration time is saved.

Air bleed between: – opening pressure 0.05 bar
– closing pressure ≥ 0.5 bar

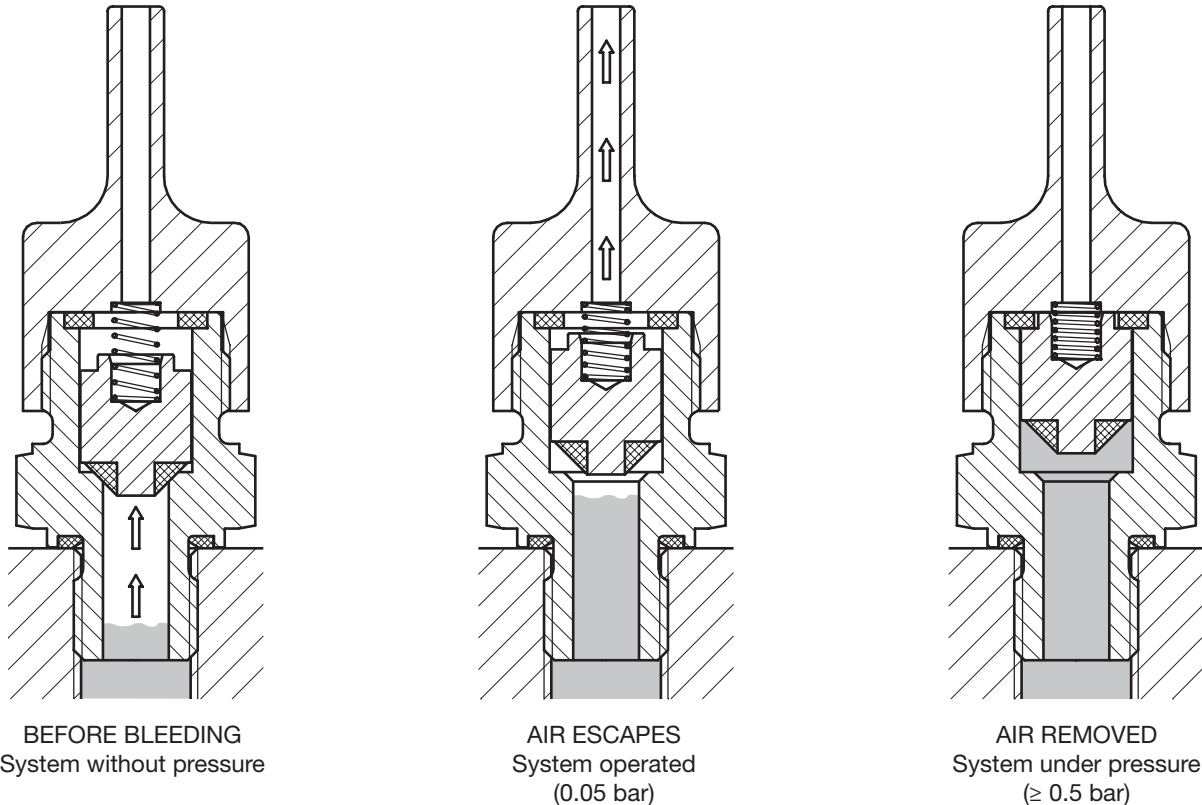

The principle of the air-bleed valve is based on the difference in behaviour of gases and liquids under pressure because of their dependence on viscosity. A piston, housed in the bore of the body with defined clearance, effects the opening and closing of the valve on start-up or shut-down of the system. On setting the system in operation, the accumulated air escapes until the liquid column of the pressure medium reaches the piston. The pressure of the liquid lifts the piston against the upper, high pressure seal, securely closing the air-vent (slight oil discharge may occur). When pressure is released the spring releases the piston reopening the air-vent, whereupon the procedure may be repeated. The special piston design prevents any intake of air in case of partial vacuum.

The air bleed valve should be connected vertical, at the highest point of the hydraulic system or in places where air accumulation may occur.

ELA air-bleed valves are available only for mineral oil based fluids, and within the temperature limits of -20°C to $+90^{\circ}\text{C}$.

ELA Air-bleed valves

Male BSPP thread with Eolastic seal

PN (bar)	Dry Technology Steel	Weight g/1 piece
400	ELA1/4EDCF	109

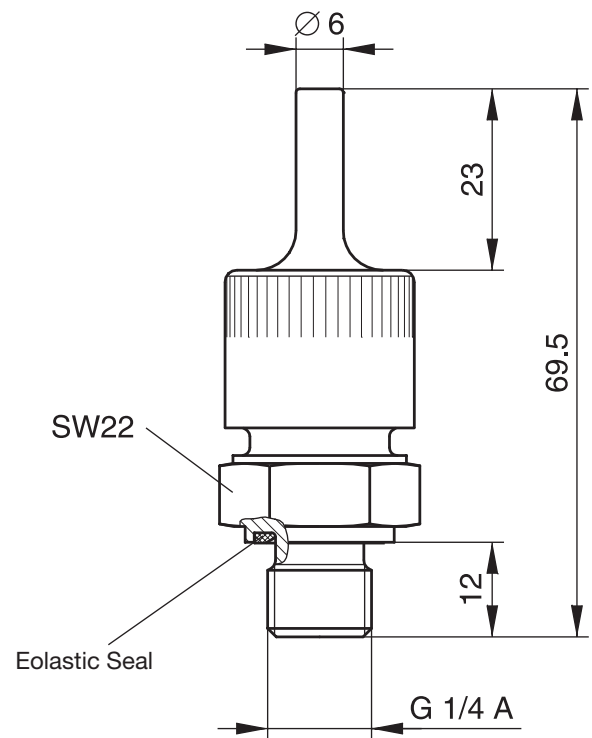

EO Swivel

PN (bar)	Dry Technology Steel	Weight g/1 piece
315	ELAE10LCF	125

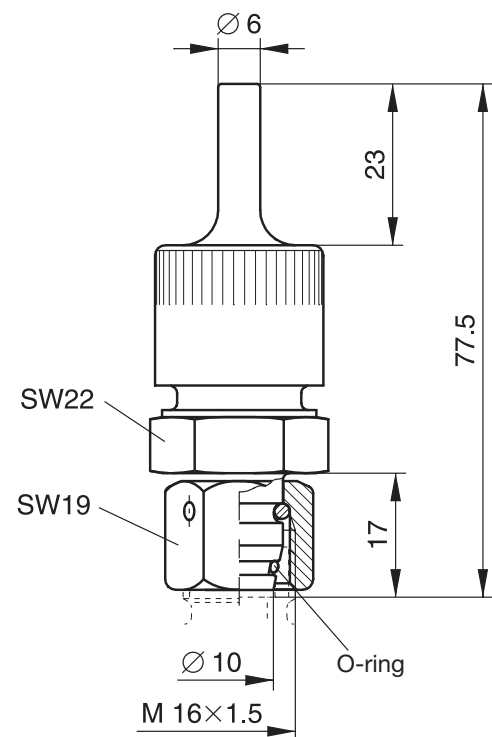

DM Technology



EO[®] Ermeto Original ***Rotary fittings***



Visual index EO rotary fittings

DG 101
p. Q6

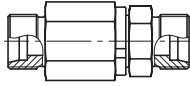

EO 24° cone end /
EO 24° cone end

DG 102-R
p. Q7

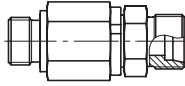

Male BSPP thread –
ED-seal (ISO 1179) / EO 24° cone end

DG 102-M
p. Q8

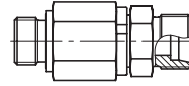

Male metric thread –
ED-seal (ISO 1179) / EO 24° cone end

DG 103
p. Q9

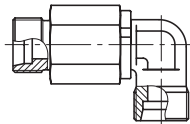

EO 24° cone end /
EO 24° cone end

DG 104-R
p. Q10

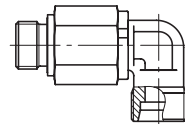

Male BSPP thread –
ED-seal (ISO 1179) / EO 24° cone end

DG 104-M
p. Q11

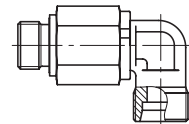

Male metric thread –
ED-seal (ISO 1179) / EO 24° cone end

DG 105
p. Q12

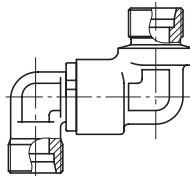

EO 24° cone end /
EO 24° cone end

DG 106-R
p. Q13

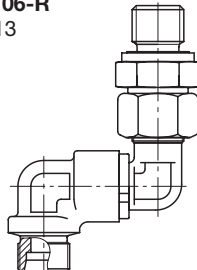

Male BSPP thread –
ED-seal (ISO 1179) / EO 24° cone end

DG 106-M
p. Q14

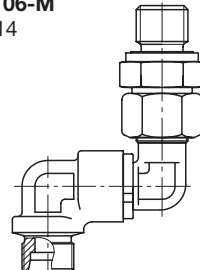

Male metric thread –
ED-seal (ISO 1179) / EO 24° cone end

DG 107
p. Q15

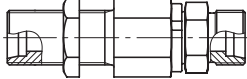

EO 24° cone end /
EO 24° cone end

DG 108
p. Q16

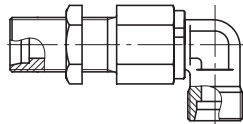

EO 24° cone end /
EO 24° cone end

DG 208
p. Q17

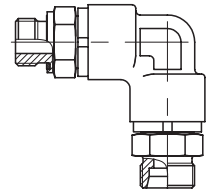

Male BSPP thread –
ED-seal (ISO 1179) / EO 24° cone end

DVGE-R
p. Q18

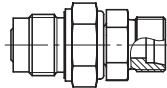

Male BSPP thread –
ED-seal / EO 24° cone end

DVGE-M
p. Q19

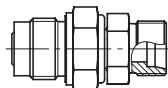

Male metric thread –
ED-seal / EO 24° cone end

DVWE-R
p. Q20

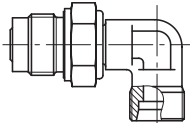

Male BSPP thread –
ED-seal / EO 24° cone end

DVWE-M
p. Q21

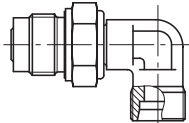

Male metric thread –
ED-seal / EO 24° cone end

DG Ball bearing rotary fittings

For working pressures up to 420 bar.
Favourable pressure/RPM ratio

Application:

Connecting a fixed point to a rotating, swinging or moving machine part via hoses.
To prevent torsion and to avoid small hose radius.

Flow media:

Hydraulic oils and lubricants on mineral oil base.
Also for hydraulic fluids HETG and HEES.
Not suitable for corrosive and HFC-fluids or gases.

Construction:

Compact, maintenance-free construction, service-proved. Combined ball and plain bearing with constant lubrication. Low starting torque. Wear-resistant annular piston sealings.

Materials:

Casing, body nut of steel, annular piston sealing: POM (e. g. Delrin)/FKM. Eolastic sealing: NBR (e.g. Perbunan), also available in FKM.

Surface:

Cr(VI)-free.

Nominal temperatures:

-40° C up to +95°C.

Warehousing:

Ball bearing rotary fittings can be stocked for 6 months. Warehousing up to 1 year is possible with storage conditions acc. to DIN 7716.

Perbunan = registered trademark of Bayer

Construction systems:

8 different versions with one rotational axis. Multiaxial rotary couplings on request. Tube connections according to DIN 2353, series S.
Maximum working pressure 420 bar (peak pressure)
Male stud sealing by Eolastic seals of NBR.
Male stud with metric parallel or BSPP thread.

Assembly instructions:

The life of a rotary fitting depends considerably on a stress-free line connection. Therefore the direct connection with tubes is to be avoided.
For connection of hoses the use of swivel nut fittings (DIN 3865) is recommended.
We recommend short, straight hose lines (free hose length approx. 5× hose O.D.). Thus shocks, vibrations etc. are absorbed.

Attention!

Maximum permissible flowrate of media: 8 m/s.

Number of revolutions and starting torques:

Chart 1

Tube O.D.	DN Nominal diameter (mm)	Permissible number of revolutions (rpm.) under a working pressure of							Initial torque at 250 bar/Nm
		25 bar	64 bar	100 bar	160 bar	250 bar	350 bar	420 bar	
6 8	5.0	1.600	800	400	200	150	90	90	max. 0.5
12 16	9.5	1.000	600	300	180	120	90	90	max. 3.0
20 25	16.0	500	250	120	60	40	20	20	max. 3.5
30 38	26.0	300	150	100	50	20	10	10	max. 5.0

DG Ball bearing rotary fittings

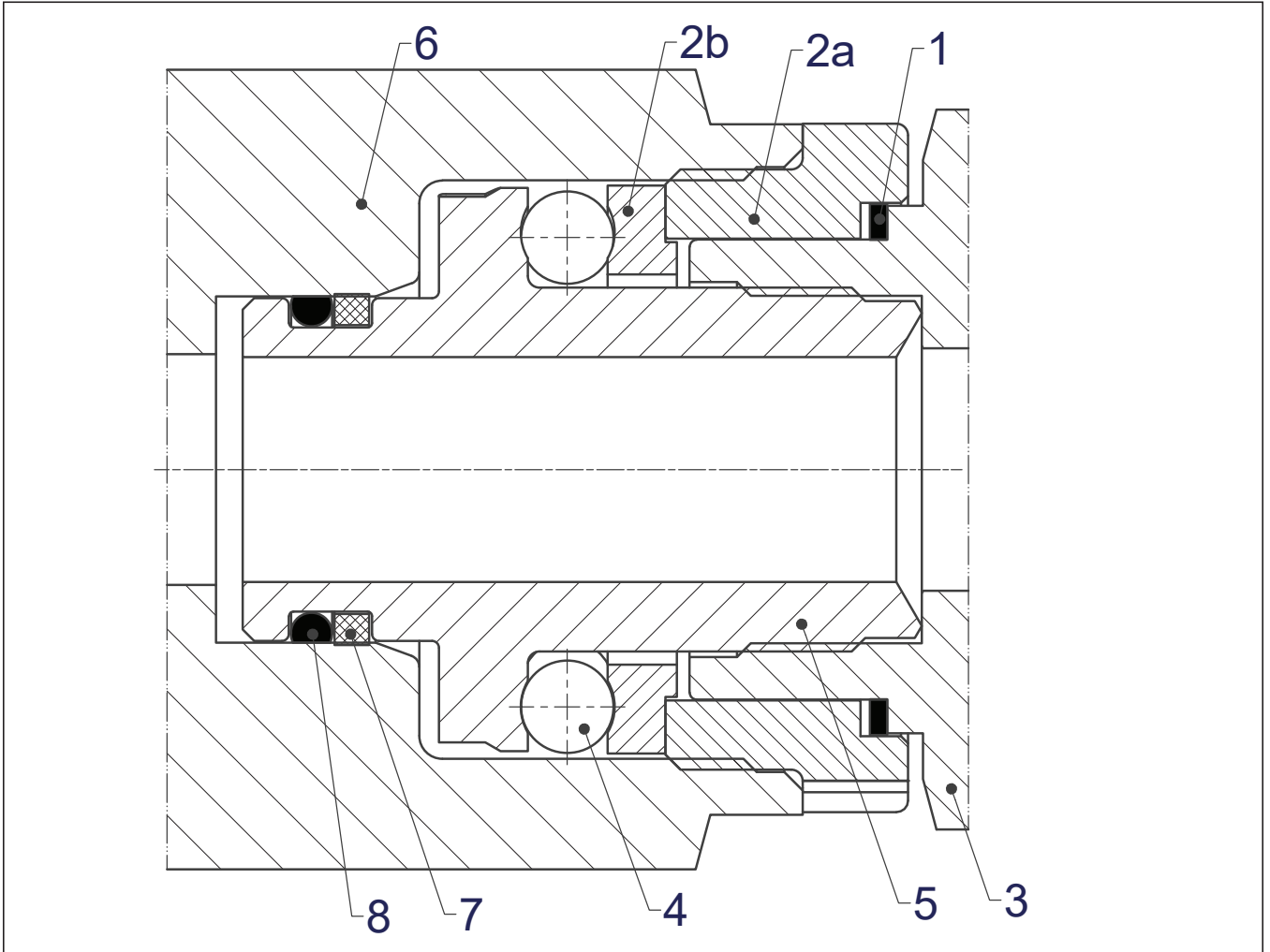

8	Sealing ring
7	Back-up ring
6	Lower part
5	Pivot
4	Ball
3	Upper part
2b	Ball race 2
2a	Ball race 1
1	dust seal
position	specification

Plain bearing rotary fittings

for slow rotating, swinging or moving machine parts up to 40 bar (series L) or up to 100 bar (series S).

Application:

Connecting a fixed point to a rotating, swinging or moving machine part via hoses.
To prevent torsion and to avoid small hose radius.

Flow media:

Hydraulic oils and lubricants on mineral oil base.
Also for hydraulic fluids HETG and HEES.
Not suitable for corrosive and HFC-fluids or gases.

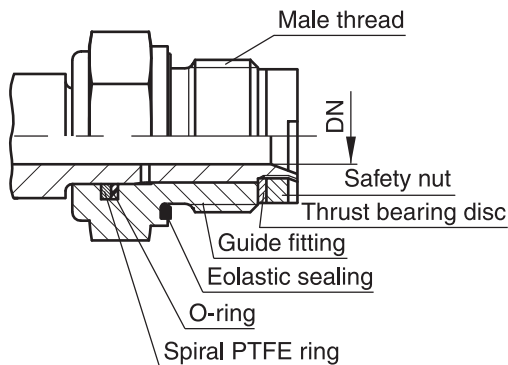

Nominal temperature:

For sealings of NBR:
-35° C up to +100° C.
For sealings of FKM:
-25° C up to +120° C.

Tube O.D.		DN Nominal diameter mm
06L	06S	4
08L	08S	5
10L	10S	6
12L	12S	8
15L	14S 16S	10
18L 22L	20S 25S	16
28L	30S	22
35L	43L 38S	25

Construction:

Compact, maintenance-free construction, service-proved.

Materials:

Casing, body nut and progressive ring of steel. Sealing of NBR (Perbunan), on request of FKM.
Plain bearing rotary fittings are not available in stainless steel or brass.

Surface:

Cr(VI)-free.

Construction-system:

Series L, tube O. D. 6 to 35 mm, working pressure (PN): 40 bar
Series S, tube O. D. 6 to 38 mm, working pressure (PN): 100 bar
Tube connection according to DIN 2353, ISO 8434-1.
Male stud with metric thread and BSP thread.
Sealing of male stud by Eolastic-seals.

Perbunan = registered trademark of Bayer

Number of revolutions:

Series	L									
Tube O.D.	6	8	10	12	15	18	22	28	35	
Permiss. no. rpm	28	28	21	17	13	10	10	7	7	
Series	S									
Tube O.D.	6	8	10	12	14	16	20	25	30	38
Permiss. no rpm	11	11	9	7	5	5	4	4	3	3

Assembly instruction:

The life of a rotary fitting depends considerably on a stress-free line connection. Therefore the direct connection with tubes is to be avoided.

For connection of hoses use of swivel nut connections (DIN 3865) is recommended.

We recommend short, straight hose lines (free hose length approx. 5x hose O. D.). Thus shocks, vibrations etc. are absorbed.

DG 101 Straight ball bearing rotary union

EO 24° cone end / EO 24° cone end

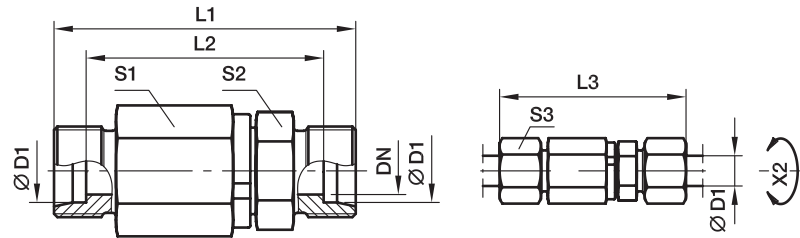

X2) Axis

Series	D1 	DN	L1	L2	L3	S1	S2	S3	Weight g/1 piece	Order code*	PN (bar) ¹⁾
S ⁴⁾	06	5.0	61	47	76	22	17	17	113	DG101/06SHDOMD	420
	08	5.0	61	47	76	22	17	19	118	DG101/08SHDOMD	420
	12	9.5	72	57	89	30	24	24	258	DG101/12SHDOMD	420
	16	9.5	74	57	93	30	27	30	264	DG101/16SHDOMD	420
	20	16.0	92	71	114	41	36	36	578	DG101/20HDSOMD	420
	25	16.0	96	72	120	41	41	46	652	DG101/25SHDOMD	420
	30	26.0	109	82	135	60	46	50	1321	DG101/30SHDOMD	420
	38	26.0	104	82	143	60	55	60	1509	DG101/38SHDOMD	420

¹⁾Pressure shown = item deliverable

⁴⁾S = heavy series

$\frac{PN \text{ (bar)}}{10} = PN \text{ (MPa)}$

Delivery without nut and ring. Information on ordering complete fittings or alternative sealing materials see page 17.

*Please add the **suffixes** below according to the material/surface required.

Order code suffixes			
Material	Suffix surface and material	Example	Standard sealing material (no additional suffix needed)
Steel, zinc plated, Cr(VI)-free	CF	DG101/06SOMDCF	VIT

DG 102-R Straight male stud ball bearing rotary union

Male BSPP thread – ED-seal (ISO 1179) / EO 24° cone end

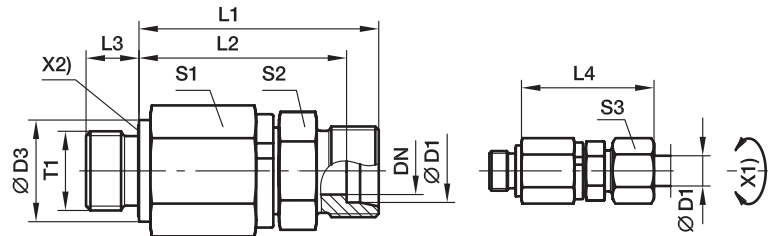

X1) Axis

X2) Eolastic-sealing

Series	D1	T1	DN	D3	L1	L2	L3	L4	S1	S2	S3	Weight g/1 piece	Order code*	PN (bar) ¹⁾
S ⁴⁾	06	G 1/4 A	5.0	19	49	42.0	12	57.0	22	17	17	110	DG102/06SRHDOMD	420
	08	G 1/4 A	5.0	19	49	42.0	12	57.0	22	17	19	116	DG102/08SRHDOMD	420
	12	G 3/8 A	9.5	24	60	52.5	12	69.0	30	24	24	243	DG102/12SRHDOMD	420
	16	G 1/2 A	9.5	27	60	51.5	14	70.0	30	27	30	256	DG102/16SRHDOMD	420
	20	G 3/4 A	16.0	32	76	65.5	16	87.5	41	36	36	558	DG102/20SRHDOMD	420
	25	G 1 A	16.0	40	78	66.0	18	90.5	41	41	46	853	DG102/25SRHDOMD	420
	30	G 1 1/4 A	26.0	50	89	75.5	20	102.0	60	46	50	1312	DG102/30SRHDOMD	420
	38	G 1 1/2 A	26.0	55	92	76.0	22	107.0	60	55	60	1494	DG102/38SRHDOMD	420

¹⁾ Pressure shown = item deliverable

⁴⁾ S = heavy series

$\frac{\text{PN (bar)}}{10} = \text{PN (MPa)}$

Delivery without nut and ring. Information on ordering complete fittings or alternative sealing materials see page 17.

*Please add the **suffixes** below according to the material/surface required.

Order code suffixes			
Material	Suffix surface and material	Example	Standard sealing material (no additional suffix needed)
Steel, zinc plated, Cr(VI)-free	CF	DG102/06SROMDCF	VIT/NBR

Rotary fittings

DG 102-M Straight male stud ball bearing rotary union

Male metric thread – ED-seal (ISO 9974) / EO 24° cone end

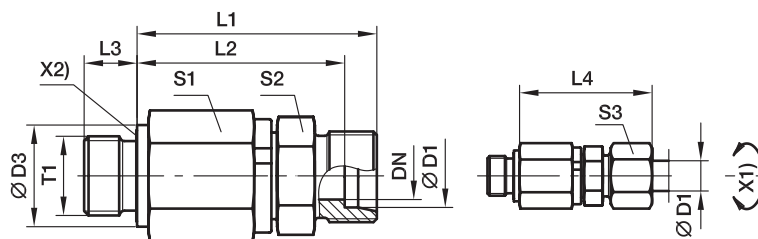
 X1) Axis
 X2) Eolastic-sealing

Series	D1	T1	DN	D3	L1	L2	L3	L4	S1	S2	S3	Weight g/1 piece	Order code*	PN (bar) ¹⁾
S ⁴⁾	06	M 14×1.5	5.0	19	49	42.0	12	57.0	22	17	17	110	DG102/06SMHDOMD	420
	08	M 14×1.5	5.0	19	49	42.0	12	57.0	22	17	19	116	DG102/08SMHDOMD	420
	12	M 18×1.5	9.5	24	60	52.5	12	69.0	30	24	24	243	DG102/12SMHDOMD	420
	16	M 22×1.5	9.5	27	60	51.5	14	70.0	30	27	30	256	DG102/16SMHDOMD	420
	20	M 27×2.0	16.0	32	76	65.5	16	87.5	41	36	36	558	DG102/20SMHDOMD	420
	25	M 33×2.0	16.0	40	78	66.0	18	90.5	41	41	46	853	DG102/25SMHDOMD	420
	30	M 42×2.0	26.0	50	89	75.5	20	102.0	60	46	50	1312	DG102/30SMHDOMD	420
	38	M 48×2.0	26.0	55	92	76.0	22	107.0	60	55	60	1494	DG102/38SMHDOMD	420

¹⁾Pressure shown = item deliverable

⁴⁾S = heavy series

$$\frac{\text{PN (bar)}}{10} = \text{PN (MPa)}$$
Delivery without nut and ring. Information on ordering complete fittings or alternative sealing materials see page 17.

*Please add the **suffixes** below according to the material/surface required.

Order code suffixes			
Material	Suffix surface and material	Example	Standard sealing material (no additional suffix needed)
Steel, zinc plated, Cr(VI)-free	CF	DG102/06SMOMDCF	VIT/NBR

DG 103 Elbow ball bearing rotary union

EO 24° cone end / EO 24° cone end

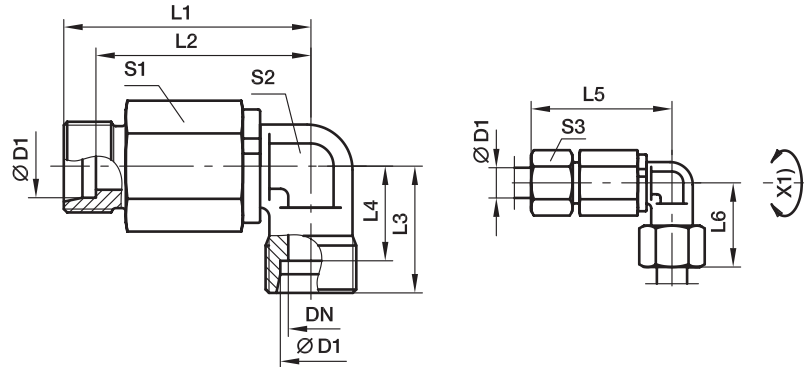

X2) Axis

Series	D1	DN	L1	L2	L3	L4	L5	L6	S1	S2	S3	Weight g/1 piece	Order code*	PN (bar) ¹⁾
S ⁴⁾	06	5.0	51.5	59.0	23	16.0	44.5	16.0	22	17	17	134	DG103/06SHDOMD	420
	08	5.0	51.5	59.0	24	17.0	44.5	17.0	22	17	19	141	DG103/08SHDOMD	420
	12	9.5	63.0	72.0	29	21.5	55.5	21.5	30	22	24	296	DG103/12SHDOMD	420
	16	9.5	63.0	73.0	33	24.5	54.5	24.5	30	22	30	298	DG103/16SHDOMD	420
	20	16.0	83.0	94.5	37	26.5	72.5	26.5	41	36	36	772	DG103/20SHDOMD	420
	25	16.0	83.0	95.5	42	30.0	71.0	30.0	41	36	46	803	DG103/25SHDOMD	420
	30	26.0	102.5	116.0	49	35.5	89.0	35.5	60	50	50	1722	DG103/30SHDOMD	420
38	26.0	102.5	117.0	57	41.0	86.5	41.0	60	50	60	1931	DG103/38SHDOMD	420	

¹⁾ Pressure shown = item deliverable

⁴⁾ S = heavy series

$\frac{PN \text{ (bar)}}{10} = PN \text{ (MPa)}$

Delivery without nut and ring. Information on ordering complete fittings or alternative sealing materials see page 17.

*Please add the **suffixes** below according to the material/surface required.

Order code suffixes			
Material	Suffix surface and material	Example	Standard sealing material (no additional suffix needed)
Steel, zinc plated, Cr(VI)-free	CF	DG103/06SOMDCF	VIT

DG 104-R Elbow male stud ball bearing rotary union

Male BSPP thread – ED-seal (ISO 1179) / EO 24° cone end

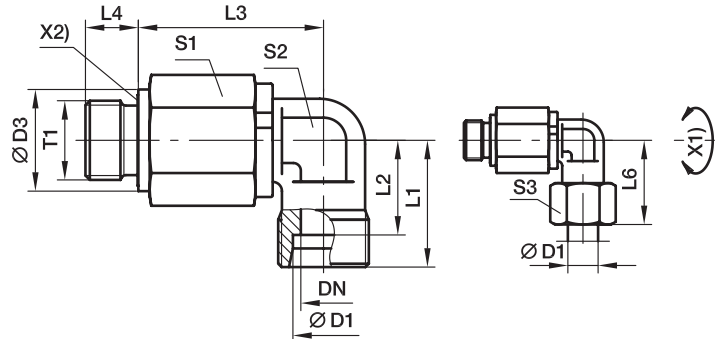

X1) Axis
X2) Eolastic-sealing

Series	D1	T1	DN	D3	L1	L2	L3	L4	L6	S1	S2	S3	Weight g/1 piece	Order code*	PN (bar) ¹⁾
S ⁴⁾	06	G 1/4 A	5.0	19	23	16.0	39.5	12	31	22	17	17	131	DG104/06SRHDOMD	420
	08	G 1/4 A	5.0	19	24	17.0	39.5	12	32	22	17	19	135	DG104/08SRHDOMD	420
	12	G 3/8 A	9.5	22	29	21.5	51.0	12	38	30	22	24	284	DG104/12SRHDOMD	420
	16	G 1/2 A	9.5	27	33	24.5	49.0	14	43	30	22	30	284	DG104/16SRHDOMD	420
	20	G 3/4 A	16.0	32	37	26.5	67.0	16	48	41	36	36	752	DG104/20SRHDOMD	420
	25	G 1 A	16.0	40	42	30.0	65.0	18	54	41	36	46	789	DG104/25SRHDOMD	420
	30	G 1 1/4 A	26.0	50	49	35.5	82.5	20	62	60	50	50	1713	DG104/30SRHDOMD	420
38	G 1 1/2 A	26.0	55	57	41.0	80.5	22	72	60	50	60	1915	DG104/38SRHDOMD	420	

¹⁾Pressure shown = item deliverable

⁴⁾S = heavy series

$\frac{PN \text{ (bar)}}{10} = PN \text{ (MPa)}$

Delivery without nut and ring. Information on ordering complete fittings or alternative sealing materials see page 17.

*Please add the **suffixes** below according to the material/ surface required.

Order code suffixes			
Material	Suffix surface and material	Example	Standard sealing material (no additional suffix needed)
Steel, zinc plated, Cr(VI)-free	CF	DG104/06SROMDCF	VIT/NBR

DG 104-M Elbow male stud ball bearing rotary union

Male metric thread – ED-seal (ISO 9974) / EO 24° cone end

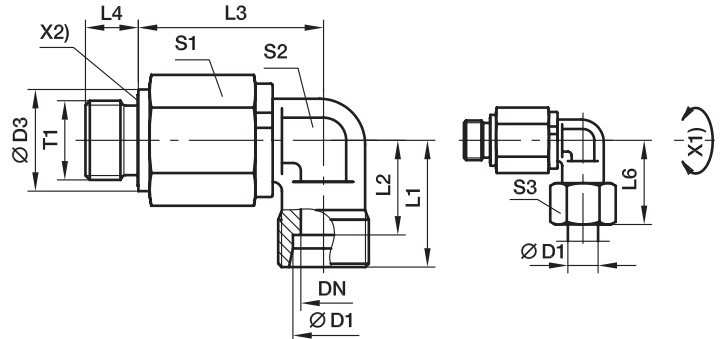

X1) Axis
X2) Eolastic-sealing

Series	D1	T1	DN	D3	L1	L2	L3	L4	L6	S1	S2	S3	Weight g/1 piece	Order code*	PN (bar) ¹⁾
S ⁴⁾	06	M 14×1.5	5.0	19	23	16.0	39.5	12	31	22	17	17	132	DG104/06SMHDOMD	420
	08	M 14×1.5	5.0	19	24	17.0	39.5	12	32	22	17	19	136	DG104/08SMHDOMD	420
	12	M 18×1.5	9.5	22	29	21.5	51.0	12	38	30	22	24	286	DG104/12SMHDOMD	420
	16	M 22×1.5	9.5	27	33	24.5	49.0	14	43	30	22	30	287	DG104/16SMHDOMD	420
	20	M 27×2.0	16.0	32	37	26.5	67.0	16	48	41	36	36	752	DG104/20SMHDOMD	420
	25	M 33×2.0	16.0	40	42	30.0	65.0	18	54	41	36	46	788	DG104/25SMHDOMD	420
	30	M 42×2.0	26.0	50	49	35.5	82.5	20	62	60	50	50	1717	DG104/30SMHDOMD	420
	38	M 48×2.0	26.0	55	57	41.0	80.5	22	72	60	50	60	1913	DG104/38SMHDOMD	420

¹⁾ Pressure shown = item deliverable

⁴⁾ S = heavy series

$\frac{PN \text{ (bar)}}{10} = PN \text{ (MPa)}$

Delivery without nut and ring. Information on ordering complete fittings or alternative sealing materials see page 17.

*Please add the **suffixes** below according to the material/surface required.

Order code suffixes			
Material	Suffix surface and material	Example	Standard sealing material (no additional suffix needed)
Steel, zinc plated, Cr(VI)-free	CF	DG104/06SMOMDCF	VIT/NBR

DG 105 Double elbow ball bearing rotary union

EO 24° cone end / EO 24° cone end

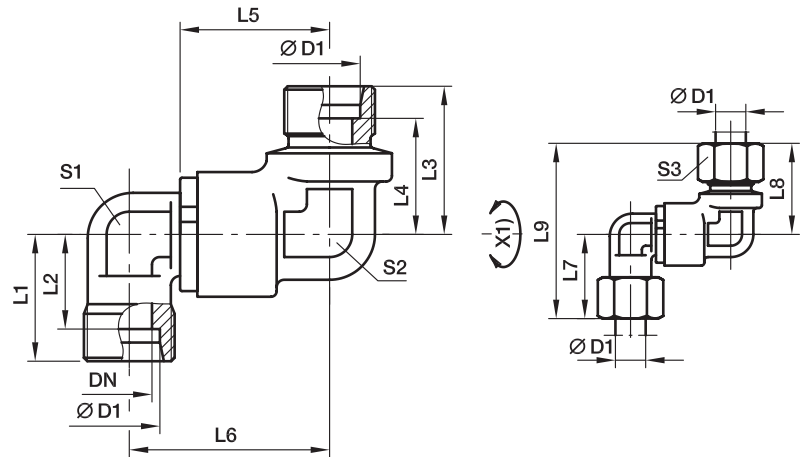

X1) Axis

Series	D1	DN	L1	L2	L3	L4	L5	L6	L7	L8	L9	S1	S2	S3	Weight g/1 piece	Order code*	PN (bar) ¹⁾
S ⁴⁾	12	9.5	39.5	26.5	43	21.5	38	81	53.0	24	22	24	29	50.5	384	DG105/12SHDOMD	420
	16	9.5	39.5	25.5	44	24.5	43	87	53.0	30	22	24	33	52.5	377	DG105/16SHDOMD	420
	20	16.0	56.5	39.5	61	26.5	48	109	76.0	36	36	32	37	71.5	1015	DG105/20SHDOMD	420
	25	16.0	56.5	38.0	62	30.0	54	116	76.0	46	36	32	42	74.0	1034	DG105/25SHDOMD	420
	30	26.0	65.0	44.5	71	35.5	62	133	92.5	50	50	50	49	84.5	2344	DG105/30SHDOMD	420
	38	26.0	65.0	42.0	73	41.0	72	145	92.5	60	50	50	57	89.0	2485	DG105/38SHDOMD	420

¹⁾Pressure shown = item deliverable

⁴⁾S = heavy series

$\frac{PN \text{ (bar)}}{10} = PN \text{ (MPa)}$

Delivery without nut and ring. Information on ordering complete fittings or alternative sealing materials see page 17.

*Please add the **suffixes** below according to the material/surface required.

Order code suffixes			
Material	Suffix surface and material	Example	Standard sealing material (no additional suffix needed)
Steel, zinc plated, Cr(VI)-free	CF	DG105/12SOMDCF	VIT

DG 106-R Double elbow male stud ball bearing rotary union

Male BSPP thread – ED-seal (ISO 1179) / EO 24° cone end
(Adjustable at male thread axis, consisting of DG105 + EGE)

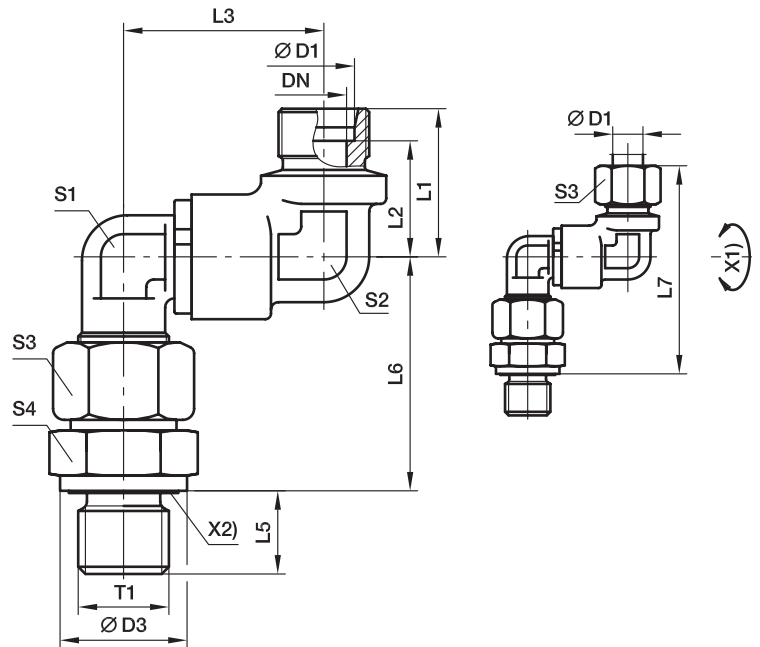

X1) Axis
X2) Eolastic-sealing

Series	D1	T1	DN	D3	L1	L2	L3	L5	L6	L7	S1	S2	S3	S4	Weight g/1 piece	Order code*	PN (bar) ¹⁾
S ⁴⁾	12	G 3/8 A	9.5	24	34	26.5	53.0	12	55.5	99	24	22	24	22	484	DG106/12SRHDOMD	420
	16	G 1/2 A	9.5	27	34	25.5	53.0	14	61.5	105	24	24	30	27	547	DG106/16SRHDOMD	420
	20	G 3/4 A	16.0	32	50	39.5	76.0	16	69.5	131	36	32	36	32	1288	DG106/20SRHDOMD	420
	25	G 1 A	16.0	40	50	38.0	76.0	18	78.0	140	36	32	46	41	1528	DG106/25SRHDOMD	420
	30	G 1 1/4 A	26.0	50	58	44.5	92.5	20	86.5	158	50	50	50	50	3004	DG106/30SRHDOMD	420
	38	G 1 1/2 A	26.0	55	58	42.0	92.5	22	101.0	174	50	50	60	55	3419	DG106/38SRHDOMD	420

¹⁾Pressure shown = item deliverable

⁴⁾S = heavy series

$\frac{\text{PN (bar)}}{10} = \text{PN (MPa)}$

Delivery without nut and ring. Information on ordering complete fittings or alternative sealing materials see page 17.

*Please add the **suffixes** below according to the material/surface required.

Order code suffixes			
Material	Suffix surface and material	Example	Standard sealing material (no additional suffix needed)
Steel, zinc plated, Cr(VI)-free	CF	DG106/06SRMDCF	VIT/NBR

DG 106-M Double elbow male stud ball bearing rotary union

Male metric thread – ED-seal (ISO 9974) / EO 24° cone end
 (Adjustable at male thread axis, consisting of DG105 + EGE)

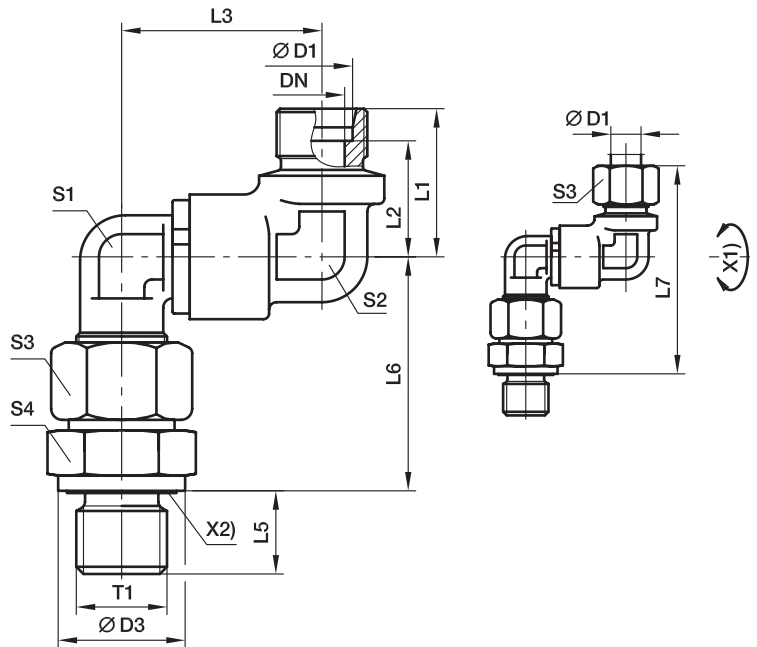

X1) Axis
 X2) Eolastic-sealing

Series	D1	T1	DN	D3	L1	L2	L3	L5	L6	L7	S1	S2	S3	S4	Weight g/1 piece	Order code*	PN (bar) ¹⁾
S ⁴⁾	12	M 18×1.5	9.5	24	34	26.5	53.0	12	55.5	99	24	22	24	24	495	DG106/12SMHDOMD	420
	16	M 22×1.5	9.5	27	34	25.5	53.0	14	61.5	105	24	24	30	27	551	DG106/16SMHDOMD	420
	20	M 27×2.0	16.0	32	50	39.5	76.0	16	69.5	131	36	32	36	32	1289	DG106/20SMHDOMD	420
	25	M 33×2.0	16.0	40	50	38.0	76.0	18	78.0	140	36	32	46	41	1532	DG106/25SMHDOMD	420
	30	M 42×2.0	26.0	50	58	44.5	92.5	20	86.5	158	50	50	50	50	3007	DG106/30SMHDOMD	420
	38	M 48×2.0	26.0	55	58	42.0	92.5	22	101.0	174	50	50	60	55	3441	DG106/38SMHDOMD	420

¹⁾Pressure shown = item deliverable

⁴⁾S = heavy series

$\frac{PN (bar)}{10} = PN (MPa)$

Delivery without nut and ring. Information on ordering complete fittings or alternative sealing materials see page 17.

*Please add the **suffixes** below according to the material/ surface required.

Order code suffixes			
Material	Suffix surface and material	Example	Standard sealing material (no additional. suffix needed)
Steel, zinc plated, Cr(VI)-free	CF	DG106/06SMOMDCF	VIT/NBR

DG 107 Straight bulkhead ball bearing rotary union

EO 24° cone end / EO 24° cone end

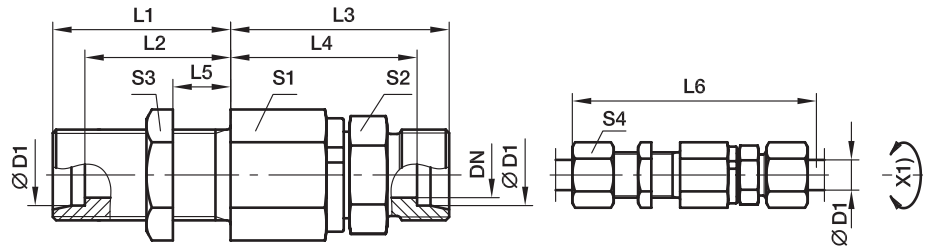

X1) Axis

Series	D1 	DN	T1	L1	L2	L3	L4	L5	L6	S1	S2	S3	S4	Weight g/1 piece	Order code*	PN (bar) ¹⁾
S ⁴⁾	06	5.0	M 14×1.5	23	16.0	49	42.0	5	87	22	17	19	17	134	DG107/06SHDOMD	420
	08	5.0	M 16×1.5	23	16.0	49	42.0	5	87	22	17	22	19	143	DG107/08SHDOMD	420
	12	9.5	M 20×1.5	23	15.5	60	52.5	5	100	30	24	27	24	291	DG107/12SHDOMD	420
	16	9.5	M 24×1.5	26	17.5	60	51.5	5	105	30	27	32	30	328	DG107/16SHDOMD	420
	20	16.0	M 30×2.0	39	28.5	76	65.5	15	137	41	36	41	36	710	DG107/20SHDOMD	420
	25	16.0	M 36×2.0	42	30.0	78	66.0	15	144	41	41	46	46	847	DG107/25SHDOMD	420
	30	26.0	M 42×2.0	44	30.5	89	75.5	15	159	60	46	50	50	1533	DG107/30SHDOMD	420
	38	26.0	M 52×2.0	47	31.0	92	76.0	15	168	60	55	65	60	1930	DG107/38SHDOMD	420

¹⁾Pressure shown = item deliverable

⁴⁾S = heavy series

$\frac{\text{PN (bar)}}{10} = \text{PN (MPa)}$

Delivery without nut and ring. Information on ordering complete fittings or alternative sealing materials see page 17.

*Please add the **suffixes** below according to the material/surface required.

Order code suffixes			
Material	Suffix surface and material	Example	Standard sealing material (no additional suffix needed)
Steel, zinc plated, Cr(VI)-free	CF	DG107/06SOMDCF	VIT

DG 108 Elbow bulkhead ball bearing rotary union

EO 24° cone end / EO 24° cone end

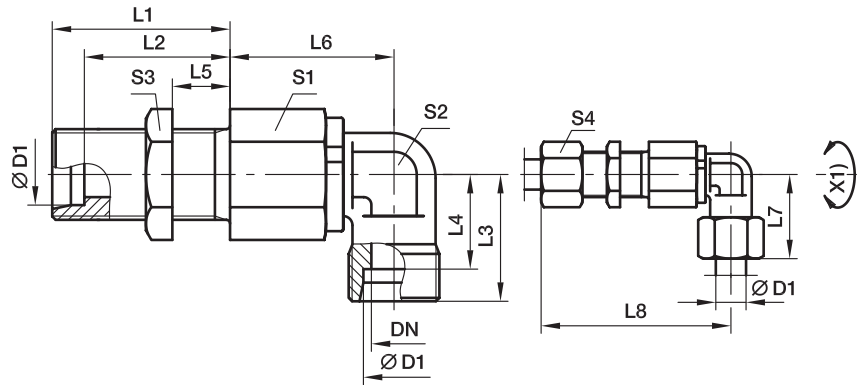

X1) Axis

Series	D1	DN	T1	L1	L2	L3	L4	L5	L6	L7	L8	S1	S2	S3	S4	Weight g/1 piece	Order code*	PN (bar) ¹⁾
S ⁴⁾	06	5.0	M 14×1.5	23	16.0	23	16.0	5	39.5	31	70.0	22	17	19	17	154	DG108/06SHDOMD	420
	08	5.0	M 16×1.5	23	16.0	23	17.0	5	39.5	32	70.0	22	17	22	19	166	DG108/08SHDOMD	420
	12	9.5	M 20×1.5	23	15.5	29	21.5	5	51.0	38	83.0	30	22	27	24	333	DG108/12SHDOMD	420
	16	9.5	M 24×1.5	26	17.5	33	24.5	5	49.0	43	85.0	30	22	32	30	354	DG108/16SHDOMD	420
	20	16.0	M 30×2.0	39	28.5	37	26.5	15	67.0	48	117.5	41	36	41	36	904	DG108/20SHDOMD	420
	25	16.0	M 36×2.0	42	30.0	42	30.0	15	65.0	54	119.5	41	36	46	45	999	DG108/25SHDOMD	420
	30	26.0	M 42×2.0	44	30.5	49	35.5	15	82.5	62	140.0	60	50	50	50	1935	DG108/30SHDOMD	420
38	26.0	M 52×2.0	47	31.0	57	41.0	15	80.5	72	142.0	60	50	65	60	2351	DG108/38SHDOMD	420	

¹⁾ Pressure shown = item deliverable

⁴⁾ S = heavy series

$$\frac{\text{PN (bar)}}{10} = \text{PN (MPa)}$$

Delivery without nut and ring. Information on ordering complete fittings or alternative sealing materials see page 17.

*Please add the **suffixes** below according to the material/surface required.

Order code suffixes			
Material	Suffix surface and material	Example	Standard sealing material (no additional suffix needed)
Steel, zinc plated, Cr(VI)-free	CF	DG108/06SOMDCF	VIT

DG 208-R Double elbow male stud ball bearing rotary union

Male BSPP thread – ED-seal (ISO 1179) / EO 24° cone end

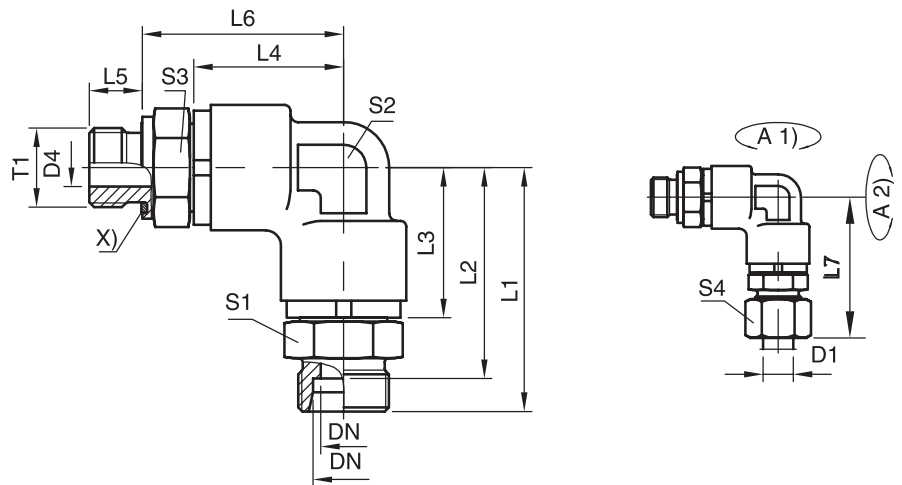

Series	D1	T1	DN	L1	L2	L3	L4	L5	L6	L7	S1	S2	S3	S4	Order code*	PN (bar) ¹⁾
S ⁴⁾	12	G 3/8 A	8	61.8	54.3	39.8	39.8	12	52.5	70.3	24	24	24	24	DG208/12SRHDOMD	420
	16	G 1/2 A	12	64.5	56.5	39.8	39.8	14	53.0	73.5	27	24	27	30	DG208/16SRHDOMD	420
	20	G 3/4 A	16	84.5	74.5	56.5	56.5	16	71.5	95.5	36	32	36	36	DG208/20SRHDOMD	420
	25	G 1 A	16	89.5	77.5	56.5	56.5	18	74.5	100.5	41	32	41	46	DG208/25SRHDOMD	420
	38	G 1 1/2 A	32	104.0	88.0	65.3	65.3	22	85.3	121.5	55	50	55	60	DG208/38SRHDOMD	420

¹⁾ Pressure shown = item deliverable

⁴⁾ S = heavy series

$\frac{\text{PN (bar)}}{10} = \text{PN (MPa)}$

Delivery without nut and ring. Information on ordering complete fittings or alternative sealing materials see page 17.

*Please add the **suffixes** below according to the material/surface required.

Order code suffixes			
Material	Suffix surface and material	Example	Standard sealing material (no additional suffix needed)
Steel, zinc plated, Cr(VI)-free	CF	DG208/12SROMDCF	VIT

DVGE-R Straight male stud plain bearing rotary union

Male BSPP thread – ED-seal / EO 24° cone end

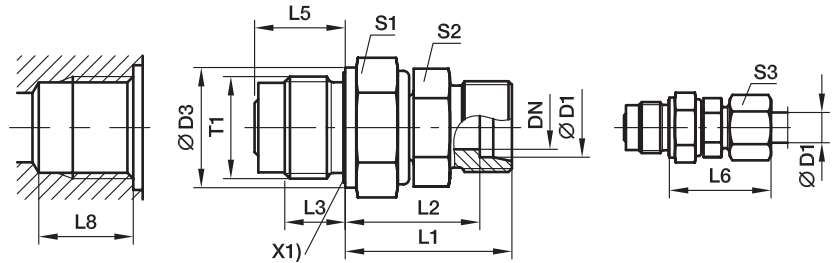

X1) Eolastic-sealing

L8 larger than DIN 3852 chart page Q22

Series	D1	T1	DN	D3	L1	L2	L3	L5	L6	S1	S2	S3	Weight g/1 piece	Order code*	PN (bar) ¹⁾	
															CF	VIT
L ³⁾	06	G 1/4 A	4	19	28.0	21.0	12	18.0	40	19	12	14	43	DVGE06LROMD	40	40
	08	G 1/4 A	5	19	28.0	21.0	12	18.0	40	19	14	17	44	DVGE08LROMD	40	40
	10	G 3/8 A	6	22	32.0	25.0	12	18.0	40	24	17	19	74	DVGE10LROMD	40	40
	12	G 1/2 A	8	27	34.0	27.0	14	21.0	42	27	19	22	116	DVGE12LROMD	40	40
	15	G 3/4 A	10	32	39.0	32.0	16	24.0	47	32	24	27	214	DVGE15LROMD	40	40
	18	G 1 A	16	40	42.5	35.0	18	27.5	51	41	27	32	337	DVGE18LROMD	40	40
	22	G 1 A	16	40	46.5	39.0	18	27.5	55	41	32	36	376	DVGE22LROMD	40	40
	28	G 1 1/4 A	22	50	48.0	40.5	20	31.0	57	50	41	41	586	DVGE28LROMD	40	40
	35	G 1 1/2 A	25	55	55.0	44.5	22	35.0	66	55	46	50	868	DVGE35LROMD	40	40
S ⁴⁾	06	G 1/4 A	4	19	30.0	23.0	12	18.0	38	19	14	17	50	DVGE06SROMD	100	100
	08	G 1/4 A	5	19	31.0	24.0	12	18.0	39	19	17	19	55	DVGE08SROMD	100	100
	10	G 3/8 A	6	22	34.0	26.5	12	18.0	43	24	19	22	85	DVGE10SROMD	100	100
	12	G 1/2 A	8	27	36.0	28.5	14	21.0	45	27	22	24	134	DVGE12SROMD	100	100
	14	G 3/4 A	10	32	41.0	33.0	16	24.0	51	32	24	27	220	DVGE14SROMD	100	100
	16	G 3/4 A	10	32	42.0	33.5	16	24.0	52	32	27	30	230	DVGE16SROMD	100	100
	20	G 1 A	16	40	48.5	38.0	18	27.5	60	41	32	36	385	DVGE20SROMD	100	100
	25	G 1 A	16	40	52.5	40.5	18	27.5	65	41	41	46	483	DVGE25SROMD	100	100
	30	G 1 1/4 A	22	50	55.0	41.5	20	31.0	68	50	46	50	691	DVGE30SROMD	100	100
	38	G 1 1/2 A	25	55	63.0	47.0	22	35.0	78	55	55	60	1080	DVGE38SROMD	100	100

¹⁾ Pressure shown = item deliverable

³⁾ L = light series; ⁴⁾ S = heavy series

$$\frac{\text{PN (bar)}}{10} = \text{PN (MPa)}$$

Delivery without nut and ring. Information on ordering complete fittings or alternative sealing materials see page 17.

*Please add the **suffixes** below according to the material/surface required.

Order code suffixes			
Material	Suffix surface and material	Example	Standard sealing material (no additional suffix needed)
Steel, zinc plated, Cr(VI)-free	CF	DVGE06LROMDCF	NBR
FKM	VITCF	DVGE06LROMDVITCF	

DVGE-M Straight male stud plain bearing rotary union

Male metric thread – ED-seal / EO 24° cone end

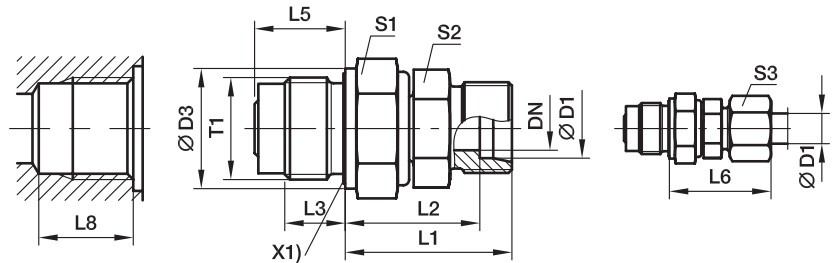

X1) Eolastic-sealing

L8 larger than DIN 3852
chart page Q22

Series	D1	T1	DN	D3	L1	L2	L3	L5	L6	S1	S2	S3	Weight g/1 piece	Order code*	PN (bar) ¹⁾	
															CF	VIT
L ³⁾	06	M 14×1.5	4	19	27.0	20.0	12	18.0	27	19	12	14	44	DVGE06LMOMD	40	40
	08	M 14×1.5	5	19	28.0	21.0	12	18.0	29	19	12	17	45	DVGE08LMOMD	40	40
	10	M 18×1.5	6	24	33.0	26.0	12	18.0	30	24	14	19	87	DVGE10LMOMD	40	40
	12	M 22×1.5	8	27	34.0	27.0	14	21.0	32	27	17	22	120	DVGE12LMOMD	40	40
	15	M 27×2.0	10	32	40.0	33.0	16	24.0	36	32	19	27	215	DVGE15LMOMD	40	40
	18	M 33×2.0	16	40	45.0	37.5	18	27.5	40	41	27	32	349	DVGE18LMOMD	40	40
	22	M 33×2.0	16	40	47.0	39.5	18	27.5	44	41	27	36	383	DVGE22LMOMD	40	40
	28	M 42×2.0	22	50	51.5	44.0	20	31.0	47	50	36	41	590	DVGE28LMOMD	40	40
	35	M 48×2.0	25	55	64.5	54.0	22	35.0	56	55	41	50	876	DVGE35LMOMD	40	40
S ⁴⁾	06	M 14×1.5	4	19	28.0	21.0	12	18.0	31	19	12	17	51	DVGE06SMOMD	100	100
	08	M 14×1.5	5	19	29.0	22.0	12	18.0	32	19	14	19	56	DVGE08SMOMD	100	100
	10	M 18×1.5	6	24	34.5	27.0	12	18.0	34	24	17	22	98	DVGE10SMOMD	100	100
	12	M 22×1.5	8	27	35.5	28.0	14	21.0	38	27	17	24	139	DVGE12SMOMD	100	100
	16	M 27×2.0	10	32	42.5	34.0	16	24.0	43	32	24	30	239	DVGE16SMOMD	100	100
	20	M 33×2.0	16	40	50.0	39.5	18	27.5	48	41	27	36	385	DVGE20SMOMD	100	100
	25	M 33×2.0	16	40	54.5	42.5	18	27.5	54	41	36	46	494	DVGE25SMOMD	100	100
	30	M 42×2.0	22	50	61.5	48.0	20	31.0	62	50	41	50	695	DVGE30SMOMD	100	100
	38	M 48×2.0	25	55	71.0	55.0	22	35.0	72	55	50	60	1088	DVGE38SMOMD	100	100

¹⁾ Pressure shown = item deliverable

³⁾ L = light series; ⁴⁾ S = heavy series

$\frac{PN(\text{bar})}{10} = PN(\text{MPa})$

Delivery without nut and ring. Information on ordering complete fittings or alternative sealing materials see page I7.

*Please add the suffixes below according to the material/surface required.

Order code suffixes			
Material	Suffix surface and material	Example	Standard sealing material (no additional suffix needed)
Steel, zinc plated, Cr(VI)-free	CF	DVGE06LMOMDCF	NBR
FKM	VITCF	DVGE06LMOMDVITCF	

DVWE-R Elbow male stud plain bearing rotary union

Male BSPP thread – ED-seal / EO 24° cone end

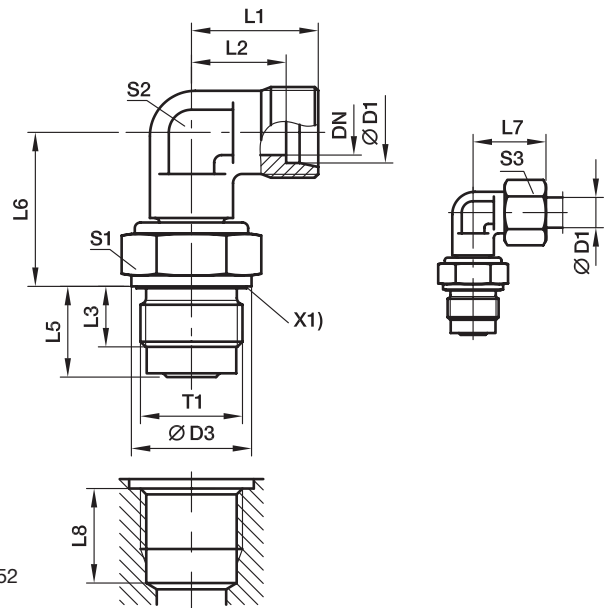

X1) Eolastic-sealing

L8 larger than DIN 3852 chart page Q22

Series	D1	T1	DN	D3	L1	L2	L3	L5	L6	L7	S1	S2	S3	Weight g/1 piece	Order code*	PN (bar) ¹⁾	CF	VIT
L ³⁾	06	G 1/4 A	4	19	19	12.0	12	18.0	20.0	27	19	12	14	50	DVWE06LROMD	40	40	
	08	G 1/4 A	5	19	21	14.0	12	18.0	21.0	29	19	12	17	50	DVWE08LROMD	40	40	
	10	G 3/8 A	6	22	22	15.0	12	18.0	26.0	30	24	14	19	83	DVWE10LROMD	40	40	
	12	G 1/2 A	8	27	24	17.0	14	21.0	27.0	32	27	17	22	129	DVWE12LROMD	40	40	
	15	G 3/4 A	10	32	28	21.0	16	24.0	33.0	36	32	19	27	232	DVWE15LROMD	40	40	
	18	G 1 A	16	40	31	23.5	18	27.5	37.5	40	41	27	32	393	DVWE18LROMD	40	40	
	22	G 1 A	16	40	35	27.5	18	27.5	39.5	44	41	27	36	406	DVWE22LROMD	40	40	
	28	G 1 1/4 A	22	50	38	30.5	20	31.0	44.0	47	50	36	41	664	DVWE28LROMD	40	40	
	35	G 1 1/2 A	25	55	45	34.5	22	35.0	54.0	56	55	41	50	1005	DVWE35LROMD	40	40	
	S ⁴⁾	06	G 1/4 A	4	19	23	16.0	12	18.0	21.0	31	19	12	17	58	DVWE06SROMD	100	100
08		G 1/4 A	5	19	24	17.0	12	18.0	22.0	32	19	14	19	65	DVWE08SROMD	100	100	
10		G 3/8 A	6	22	25	17.5	12	18.0	27.0	34	24	17	22	103	DVWE10SROMD	100	100	
12		G 1/2 A	8	27	29	21.5	14	21.0	28.0	38	27	17	24	152	DVWE12SROMD	100	100	
14		G 3/4 A	10	32	30	22.0	16	24.0	33.0	40	32	19	27	236	DVWE14SROMD	100	100	
16		G 3/4 A	10	32	33	24.5	16	24.0	34.0	43	32	24	30	276	DVWE16SROMD	100	100	
20		G 1 A	16	40	37	26.5	18	27.5	39.5	48	41	27	36	415	DVWE20SROMD	100	100	
25		G 1 A	16	40	42	30.0	18	27.5	42.5	54	41	36	46	569	DVWE25SROMD	100	100	
30		G 1 1/4 A	22	50	49	35.5	20	31.0	48.0	62	50	41	50	886	DVWE30SROMD	100	100	
38		G 1 1/2 A	25	55	57	41.0	22	35.0	55.0	72	55	50	60	1375	DVWE38SROMD	100	100	

¹⁾Pressure shown = item deliverable

³⁾L = light series; ⁴⁾S = heavy series

$$\frac{PN \text{ (bar)}}{10} = PN \text{ (MPa)}$$

Delivery without nut and ring. Information on ordering complete fittings or alternative sealing materials see page 17.

*Please add the suffixes below according to the material/surface required.

Order code suffixes			
Material	Suffix surface and material	Example	Standard sealing material (no additional suffix needed)
Steel, zinc plated, Cr(VI)-free	CF	DVWE06LROMDCF	NBR
FKM	VITCF	DVWE06LROMDVITCF	

DVWE-M Elbow male stud plain bearing rotary union

Male metric thread – ED-seal / EO 24° cone end

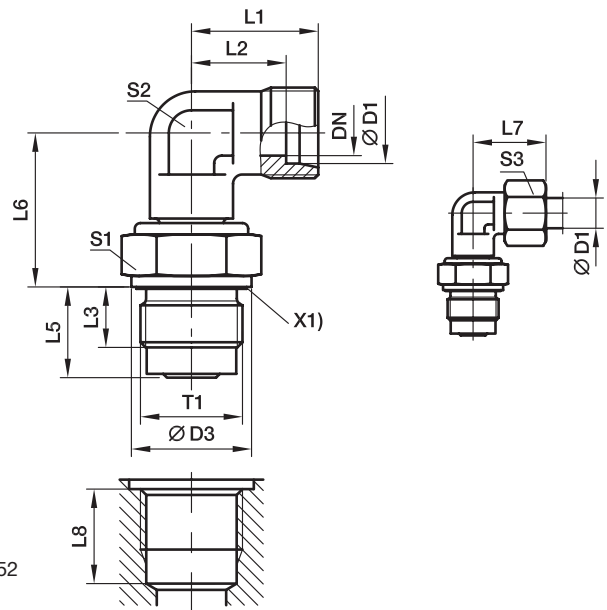

X1) Elastomeric-sealing

L8 larger than DIN 3852
chart page Q22

Series	D1	T1	DN	D3	L1	L2	L3	L5	L6	L7	S1	S2	S3	Weight g/1 piece	Order code*	PN (bar) ¹⁾	
															CF	VIT	
L ³⁾	06	M 14×1.5	4	19	19	12.0	12	18.0	20.0	27	19	12	14	51	DVWE06LMOMD	40	40
	08	M 14×1.5	5	19	21	14.0	12	18.0	21.0	29	19	12	17	51	DVWE08LMOMD	40	40
	10	M 18×1.5	6	24	22	15.0	12	18.0	26.0	30	24	14	19	92	DVWE10LMOMD	40	40
	12	M 22×1.5	8	27	24	17.0	14	21.0	27.0	32	27	17	22	160	DVWE12LMOMD	40	40
	15	M 27×2.0	10	32	28	21.0	16	24.0	33.0	36	32	19	27	236	DVWE15LMOMD	40	40
	18	M 33×2.0	16	40	31	23.5	18	27.5	37.5	40	41	27	32	405	DVWE18LMOMD	40	40
	22	M 33×2.0	16	40	35	27.5	18	27.5	39.5	44	41	27	36	409	DVWE22LMOMD	40	40
	28	M 42×2.0	22	50	38	30.5	20	31.0	44.0	47	50	36	41	660	DVWE28LMOMD	40	40
	35	M 48×2.0	25	55	45	34.5	22	35.0	54.0	56	55	41	50	1012	DVWE35LMOMD	40	40
	S ⁴⁾	06	M 14×1.5	4	19	23	16.0	12	18.0	21.0	31	19	12	17	59	DVWE06SMOMD	100
08		M 14×1.5	5	19	24	17.0	12	18.0	22.0	32	19	14	19	66	DVWE08SMOMD	100	100
10		M 18×1.5	6	24	25	17.5	12	18.0	27.0	34	24	17	22	113	DVWE10SMOMD	100	100
12		M 22×1.5	8	27	29	21.5	14	21.0	28.0	38	27	17	24	153	DVWE12SMOMD	100	100
16		M 27×2.0	10	32	33	24.5	16	24.0	34.0	43	32	24	30	284	DVWE16SMOMD	100	100
20		M 33×2.0	16	40	37	26.5	18	27.5	39.5	48	41	27	36	427	DVWE20SMOMD	100	100
25		M 33×2.0	16	40	42	30.0	18	27.5	42.5	54	41	36	46	581	DVWE25SMOMD	100	100
30		M 42×2.0	22	50	49	35.5	20	31.0	48.0	62	50	41	50	898	DVWE30SMOMD	100	100
38		M 48×2.0	25	55	57	41.0	22	35.0	55.0	72	55	50	60	1373	DVWE38SMOMD	100	100

¹⁾ Pressure shown = item deliverable

³⁾ L = light series; ⁴⁾ S = heavy series

$$\frac{\text{PN (bar)}}{10} = \text{PN (MPa)}$$

Delivery without nut and ring. Information on ordering complete fittings or alternative sealing materials see page I7.

*Please add the suffixes below according to the material/surface required.

Order code suffixes			
Material	Suffix surface and material	Example	Standard sealing material (no additional suffix needed)
Steel, zinc plated, Cr(VI)-free	CF	DVWE06LMOMDCF	NBR
FKM	VITCF	DVWE06LMOMDVITCF	

Port tapping for plain bearing rotary fittings DVGE and DVWE

Port tapping form X
according to DIN 3852, part 1 and part 2
(for parallel male studs)

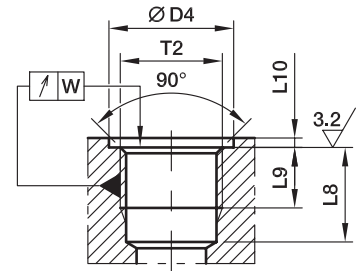

Thread d1	d4 small +0.4	a ₁ max	L9 min	L8 min	W
M 14×1.5	20	1.5	12	19.0	0.1
M 18×1.5	25 ²⁾	2.0	12	19.0	0.1
M 22×1.5	28	2.5	14	22.0	0.1
M 27×2.0	33	2.5	16	25.0	0.2
M 33×2.0	41 ²⁾	2.5	18	28.5	0.2
M 42×2.0	51 ²⁾	2.5	20	32.0	0.2
M 48×2.0	56	2.5	22	36.0	0.2
G 1/4 A	20 ²⁾	1.5	12	19.0	0.1
G 3/8 A	23	2.0	12	19.0	0.1
G 1/2 A	28 ²⁾	2.5	14	22.0	0.1
G 3/4 A	33	2.5	16	25.0	0.2
G 1 A	41 ²⁾	2.5	18	28.5	0.2
G 1 1/4 A	51 ²⁾	2.5	20	32.0	0.2
G 1 1/2 A	56	2.5	22	36.0	0.2

¹⁾ Not in DIN 3852

²⁾ Different from DIN 3852



***SensoControl®
Test Points
Diagnostic-
Test equipment
Industrial Products***



Visual index

Series 1

Test point fitting with pin-lock

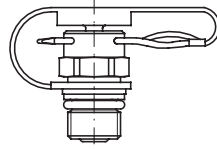

EMA1
p. R4

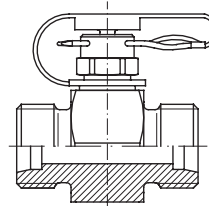

GMA1
p. R5

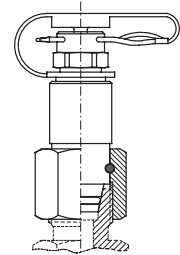

VKA1
p. R6

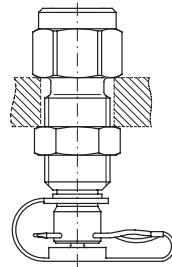

MAV ... MA1
p. R7

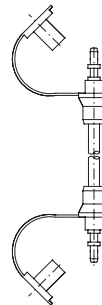

SMA1
p. R7

Series 3

Test point with threaded connection
M 16x2

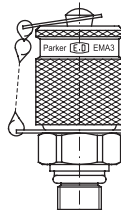

EMA3
p. R8

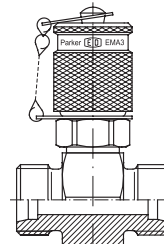

GMA3
p. R9

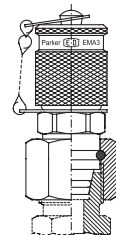

VKA3
p. R10

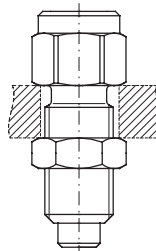

MAV ... MA3
p. R11

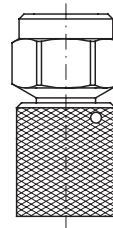

MAVMD ... MA3
p. R11

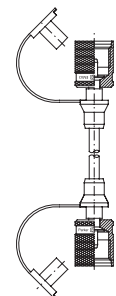

SMA3
p. R11

SensoControl®

Product range

Diagnostic/Industrial



p. R12

EMA1/EMA3-Test Point fitting

- For pressure monitoring and checking on high, low and negative pressure systems.
- For bleeding cylinders and hydraulic systems.
- For taking samples on high, low and negative pressure systems.

Advantages:

- Leakfree connection before valve is open
- Sturdy, safe constructions for small dimensions
- Easy handling
- Simple connection of measuring, control and switching devices
- Coupling under pressure up to 400 bar is possible with screw couplings
- Nominal pressures up to 630 bar
- Self locking metal guard cap, vibration resistant

Sealing system of the primary seal:

EMA1 by ball non-return valve.

EMA3 by cone seal with O-ring.

The new EMA3 sealing system guarantees minimum leakage rates.

The screw-on Cap (EMA3), and pin lock (EMA1) types both employ an O-ring seal as secondary sealing with the hose attached.

Differences between EMA1 and EMA3 types

- a) sealing system (see previous section)
- b) Test hose connection by plug-in coupling in EMA1
Test hose connection by threaded connection in EMA3
- c) Working pressures (see section advantages)

Working pressure

- EMA3 types up to 630 bar
- EMA1 types up to 400 bar
- Max. working pressure 630 bar for GMA, VKA and EMA... the recommended working pressure of fitting manufacturer has to be applied
- Joining under pressure up to 400 bar max.
- The allowable nominal pressures of each Test-Point are shown on the product pages.

Materials and Temperatures:

- Steel, zinc plated, Cr(VI)-free
- Stainless Steel, material 1.4571
- Seals:
- FKM (Temperature range -20 to $+200^{\circ}\text{C}$)
- EPDM Ethylene Propylene (for Break Fluid) (Temperature range -40 to $+150^{\circ}\text{C}$)
- Internal seals are always FKM
- Hose:
- Polyamide (Temperature range: -35°C ... 100°C max.)
- Stainless Steel FKM only

Media:

- Suitable for hydraulic oils and other mineral oil based fluids (Please pay attention to the sealing materials used!)
- For use in conjunction with other liquid media please consult Parker

Standards

ISO15171-2

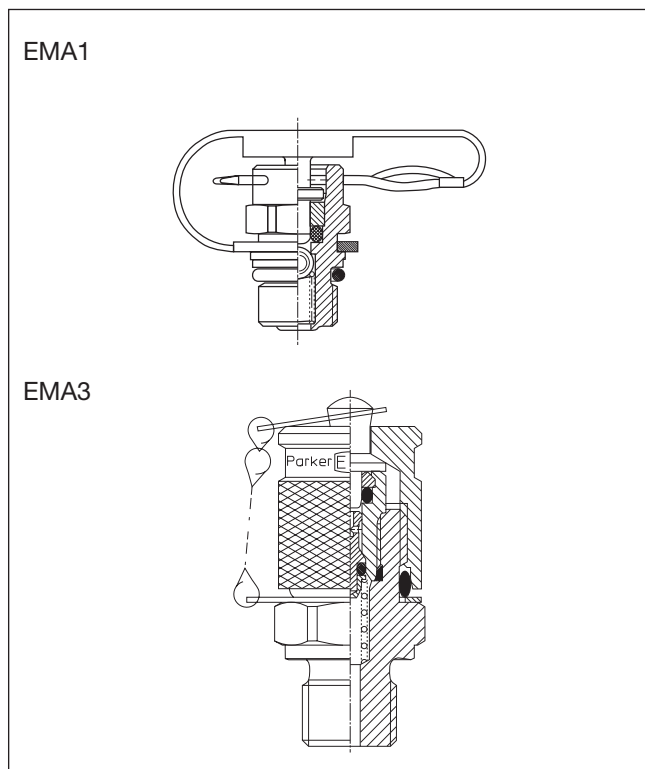

Perbunan = registered trademark of Bayer

EMA1 Test point fitting with pin-lock

Series 1

Male stud thread: BSP, metric

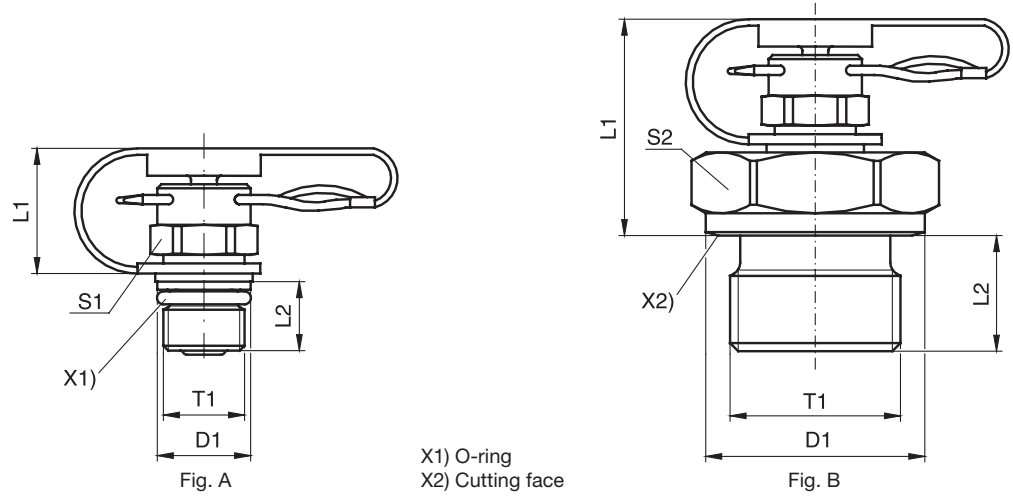

T1	D1	L1	L2	S1	S2	Fig.	Weight g/1 piece	Order code*	PN (bar) ¹⁾ CF	DF**
M 12x1.5	17.0	32.0	12.0		19	B	53	EMA1/12X1.5	400	4
M 14x1.5	19.0	32.0	12.0		19	B	56	EMA1/14X1.5	400	4
M 16x1.5	21.0	25.0	12.0		22	B	47	EMA1/16X1.5	400	4
G 1/8	14.0	32.5	8.0		17	B	41	EMA1/1/8	400	4
G 1/4	18.0	32.0	12.0		19	B	54	EMA1/1/4	400	4
G 3/8	22.0	27.5	12.0		22	B	55	EMA1/3/8	400	4
G 1/2	26.0	27.5	14.0		27	B	78	EMA1/1/2	400	4
M 08x1.0	9.5	17.5	8.4	12		A	16	EMA1/8X1OR	400	4
M 10x1.0	11.5	18.0	8.0	12		A	18	EMA1/10X1OR	400	4
M 10x1.0	14.0	32.5	8.0		17	B	42	EMA1/10X1	400	4

**DF = Design Factor

¹⁾Pressure shown = item deliverable

$$\frac{PN \text{ (bar)}}{10} = PN \text{ (MPa)}$$

*Please add the **suffixes** below according to the material/ surface required.

Order code suffixes			
Material	Suffix surface and material	Example	Standard sealing material (no additional suffix needed)
Steel, zinc plated, Cr(VI)-free	CF	EMA1/12X1.5CF	NBR

GMA1 Straight test point fitting with pin-lock

Series 1

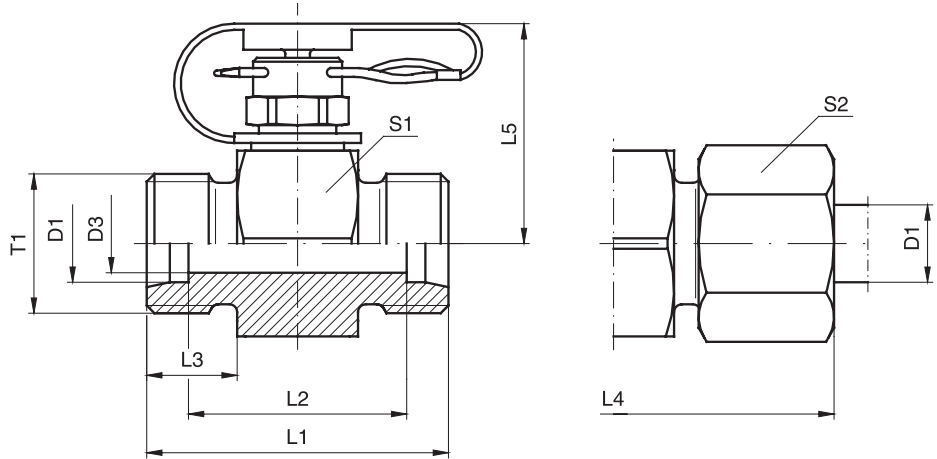

Series	D1	T1	D3	L1	L2	L3	L4	L5	S1	S2	Weight g/1 piece	Order code*	PN (bar) ¹⁾ CF	DF ^{**}
L ³⁾	06	M 12×1.5	4	35	21	10	51	29.0	24	14	73	GMA1/06LOMD	315	4
	08	M 14×1.5	6	35	21	10	51	29.0	24	17	75	GMA1/08LOMD	315	4
	10	M 16×1.5	7	37	23	11	53	29.0	24	19	80	GMA1/10LOMD	315	4
	12	M 18×1.5	8	37	23	11	53	30.5	24	22	96	GMA1/12LOMD	315	4
	15	M 22×1.5	11	39	25	12	55	32.0	30	27	121	GMA1/15LOMD	315	4
	18	M 26×1.5	14	39	24	12	57	33.0	32	32	139	GMA1/18LOMD	315	4
	22	M 30×2.0	18	43	28	14	61	35.0	36	36	171	GMA1/22LOMD	160	4
S ⁴⁾	06	M 14×1.5	4	39	25	12	55	29.0	24	17	82	GMA1/06SOMD	400	4
	08	M 16×1.5	5	39	25	12	55	29.0	24	19	88	GMA1/08SOMD	400	4
	10	M 18×1.5	7	39	24	12	57	29.0	24	22	90	GMA1/10SOMD	400	4
	12	M 20×1.5	7	39	24	12	57	29.0	24	24	96	GMA1/12SOMD	400	4
	14	M 22×1.5	10	43	27	14	63	30.5	27	27	121	GMA1/14SOMD	400	4
	16	M 24×1.5	11	43	26	14	63	32.0	30	30	138	GMA1/16SOMD	400	4
	20	M 30×2.0	15	47	26	16	69	35.0	36	36	222	GMA1/20SOMD	400	4

**DF = Design Factor

¹⁾Pressure shown = item deliverable

³⁾L = light series; ⁴⁾S = heavy series

$$\frac{PN \text{ (bar)}}{10} = PN \text{ (MPa)}$$

Delivery without nut and ring. Information on ordering complete fittings or alternative sealing materials see page 17.



*Please add the **suffixes** below according to the material/surface required.

Order code suffixes			
Material	Suffix surface and material	Example	Standard sealing material (no additional suffix needed)
Steel, zinc plated, Cr(VI)-free	CF	GMA1/06LOMDCF	NBR

VKA1 Test point fitting with pin lock for cones **Series 1**

With 24° cone swivel nut connection

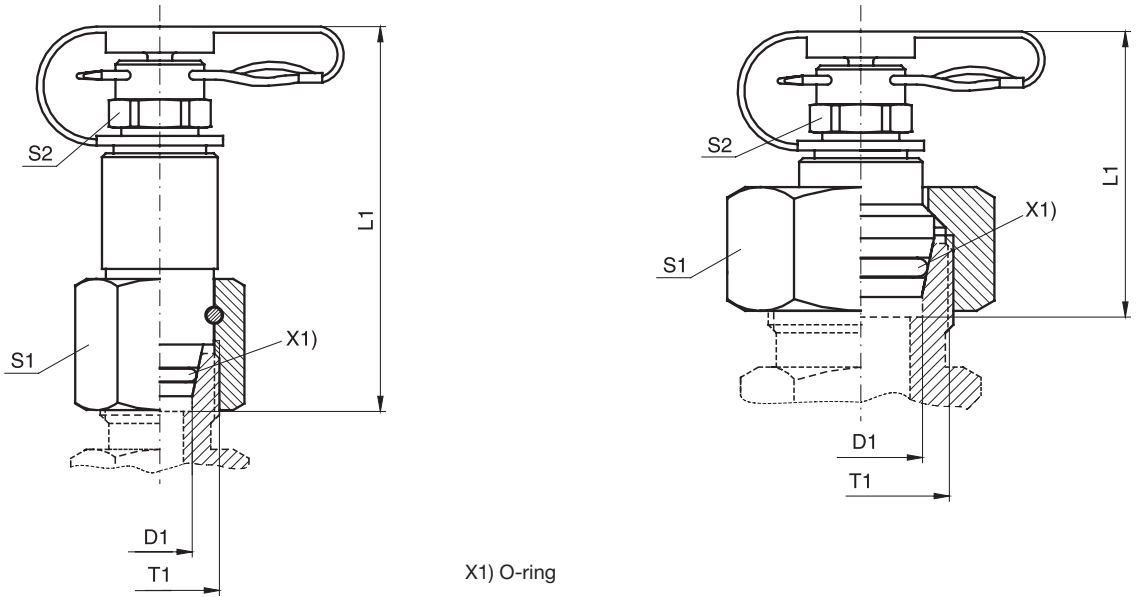

Series	D1	T1	L1	S1	S2	Fig.	Weight g/1 piece	Order code*	PN (bar) ¹⁾ CF	DF ²⁾
L ³⁾	06	M 12×1.5	48	14	12	A	44	VKA1/06L	315	4
	08	M 14×1.5	49	17	12	A	54	VKA1/08L	315	4
	10	M 16×1.5	50	19	12	A	68	VKA1/10L	315	4
	12	M 18×1.5	51	22	12	A	81	VKA1/12L	315	4
	15	M 22×1.5	39	27	12	B	82	VKA1/15L	315	4
	18	M 26×1.5	38	32	12	B	112	VKA1/18L	315	4
S ⁴⁾	06	M 14×1.5	48	17	12	A	51	VKA1/06S	400	4
	08	M 16×1.5	50	19	12	A	62	VKA1/08S	400	4
	10	M 18×1.5	50	22	12	A	78	VKA1/10S	400	4
	12	M 20×1.5	51	24	12	A	100	VKA1/12S	400	4
	14	M 22×1.5	39	27	12	B	88	VKA1/14S	400	4
	16	M 24×1.5	37	30	12	B	105	VKA1/16S	400	4
	20	M 30×2.0	44	36	12	B	174	VKA1/20S	400	4

**DF = Design Factor

¹⁾Pressure shown = item deliverable

³⁾L = light series; ⁴⁾S = heavy series

$$\frac{PN \text{ (bar)}}{10} = PN \text{ (MPa)}$$

*Please add the **suffixes** below according to the material/surface required.

Order code suffixes			
Material	Suffix surface and material	Example	Standard sealing material (no additional suffix needed)
Steel, zinc plated, Cr(VI)-free	CF	VKA1/06LCF	NBR

MAV-MA1 Test Point pressure gauge connector with pin-lock
SMA1 Test Point high pressure hose with pin-lock **Series 1**

Female thread: BSP
 Sealing: sealing ring DIN 16258

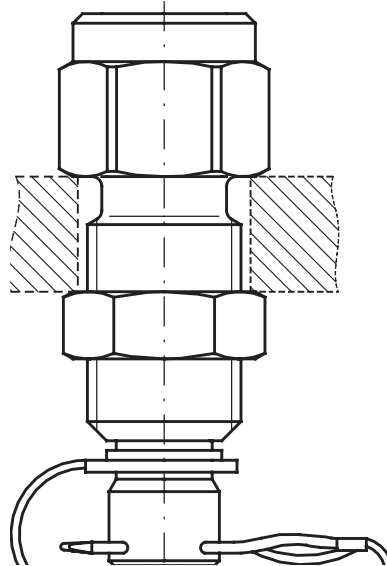

Pressure gauge connector: MAV-MA1

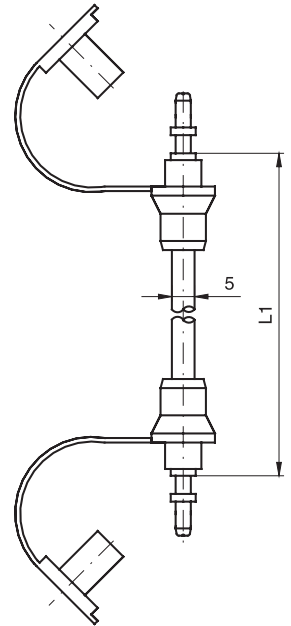

Test hose: SMA1

T1	L1	L2 max.	S1	S2	Weight g/1 piece	Order code*	PN (bar) ¹⁾ CF	DF**
G 1/4	61.5	12	19	19	78	MAV1/4MA1	400	4.0
G 1/2	72.0	12	27	19	135	MAV1/2MA1	400	4.0
	400.0				21	SMA1-400	400	2.5
	630.0				26	SMA1-630	400	2.5
	800.0				26	SMA1-800	400	2.5
	1000.0				31	SMA1-1000	400	2.5
	1500.0				40	SMA1-1500	400	2.5
	2000.0				49	SMA1-2000	400	2.5
	2500.0				58	SMA1-2500	400	2.5
	3200.0				70	SMA1-3200	400	2.5
	4000.0				84	SMA1-4000	400	2.5

**DF = Design Factor

¹⁾Pressure shown = item deliverable

$$\frac{PN \text{ (bar)}}{10} = PN \text{ (MPa)}$$

*Please add the **suffixes** below according to the material/surface required.

Order code suffixes			
Material	Suffix surface and material	Example	Standard sealing material (no additional suffix needed)
Steel, zinc plated, Cr(VI)-free	CF	MAV1/4MA1CF	NBR

Note hoses with small diameter:

- Min. bending radius r = 20 mm
- Working temperature -20 °C up to 100 °C (short time to +120 °C)
- Hoses are to be protected from fire, from sharp-corners and hot objects.

For measuring with liquid pressure media please note:
 Bleed before connecting tube! By capillary action discharge of the pressure medium is prevented widely.

Temperature factor of pressure rating:

up to 0 °C	122 %
for 30 °C	110 %
for 50 °C	100 %
for 80 °C	86 %
for 100 °C	77 %

EMA3 Test Point with threaded connection M 16×2

Series 3

Male thread: BSP, metric

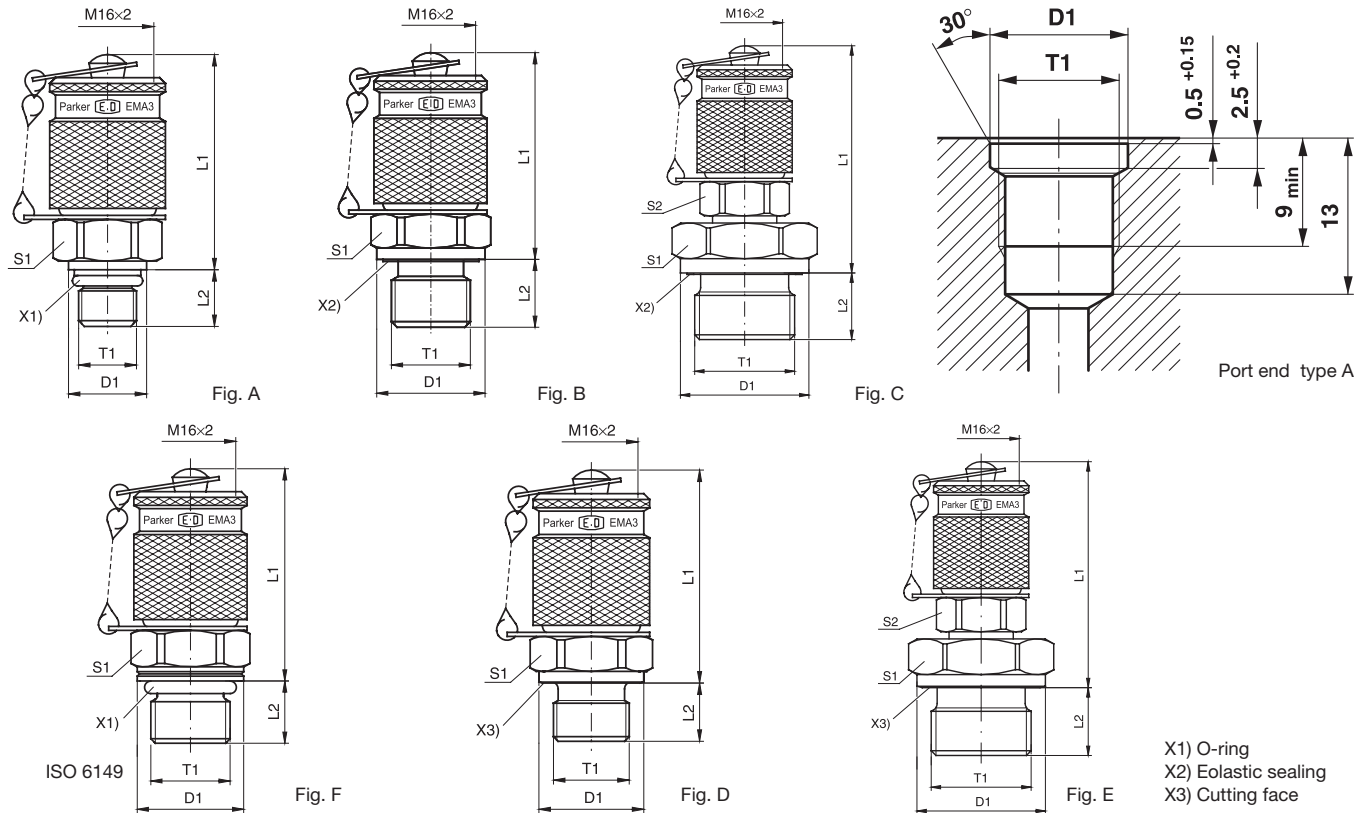

T1	D1	L1	L2	S1	S2	Fig.	Weight g/1 piece	Order code*	PN (bar) ¹⁾		DF**	
									CF	71	CF	71
M 08×1.0	9.5	38.5	7.5	17		A	66	EMA3/8X1OR	250		4.0	
M 10×1.0	11.5	37.0	7.5	17		A	70	EMA3/10X1OR	630	630	4.0	4
M 14×1.5	18.8	39.5	11.0	19		F	79	EMA3/14X1.5ISO	630	630	4.0	4
M 10×1.0	14.0	40.0	8.0	17		D	67	EMA3/10X1	400		4.0	
M 12×1.5	17.0	38.0	12.0	17		D	74	EMA3/12X1.5	400		4.0	
M 14×1.5	19.0	39.0	12.0	19		D	78	EMA3/14X1.5	400		4.0	
M 16×1.5	21.0	40.0	12.0	22		D	90	EMA3/16X1.5	400		4.0	
G 1/8	14.0	37.5	8.0	17		D	70	EMA3/1/8	400		4.0	
G 1/4	18.0	39.0	12.0	19		D	77	EMA3/1/4	400		4.0	
G 3/8	22.0	40.5	12.0	22		D	91	EMA3/3/8	400		4.0	
G 1/2	26.0	46.0	14.0	27	17	E	137	EMA3/1/2	400		3.4	
G 1/8	14.0	37.5	8.0	17		B	72	EMA3/1/8ED	400	400	4.0	4
G 1/4	19.0	39.0	12.0	19		B	76	EMA3/1/4ED	630	630	4.0	4
G 3/8	22.0	40.5	12.0	22		B	93	EMA3/3/8ED	630	630	4.0	4
M 10×1.0	14.0	40.0	8.0	17		B	71	EMA3/10X1ED	400	400	4.0	4
M 12×1.5	17.0	38.0	12.0	17		B	72	EMA3/12X1.5ED	630	630	4.0	4
M 14×1.5	19.0	39.0	12.0	19		B	77	EMA3/14X1.5ED	400	400	4.0	4
G 1/2	27.0	46.0	14.0	27	17	C	135	EMA3/1/2ED	400	400	4.0	4

**DF = Design Factor

¹⁾Pressure shown = item deliverable

$$\frac{PN \text{ (bar)}}{10} = PN \text{ (MPa)}$$

*Please add the **suffixes** below according to the material/ surface required.

Order code suffixes			
Material	Suffix surface and material	Example	Standard sealing material (no additional suffix needed)
Steel, zinc plated, Cr(VI)-free	CF	EMA3/10X10ORCF	NBR
Stainless Steel	71	EMA3/10X10OR71	VIT
Stainless Steel	316L	EMA3/1/4ED316L	NBR

GMA3 Straight Test Point with threaded connection M 16×2

Series 3

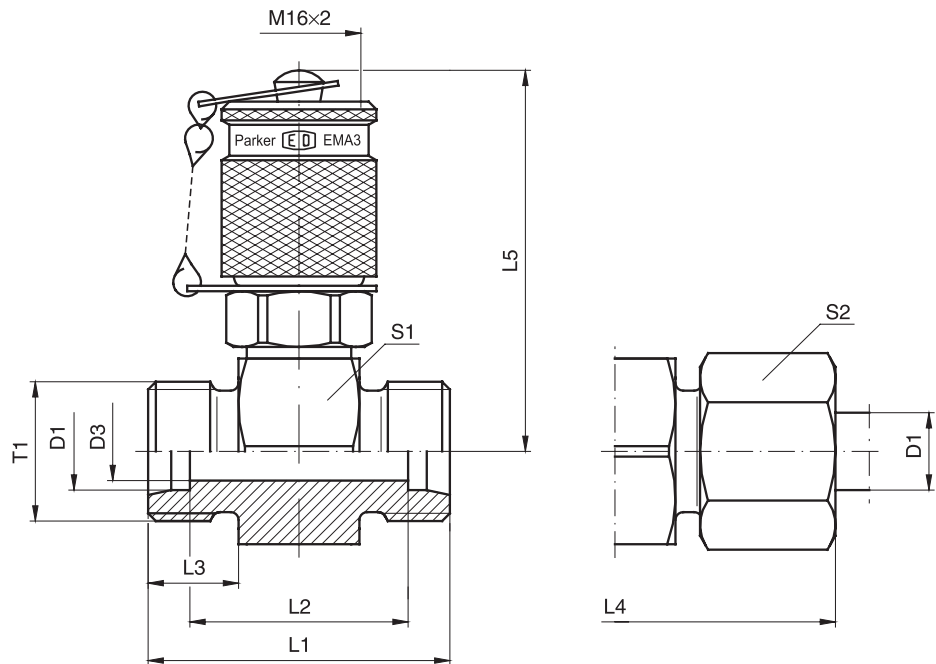

Series	D1	T1	D3	L1	L2	L3	L4	L5	S1	S2	Weight g/1 piece	Order code*	PN (bar) ¹⁾		DF**	
													CF	71	CF	71
L ³⁾	06	M 12×1.5	4	35	21	10	51	49.0	24	14	126	GMA3/06LOMD	315	315	4	4
	08	M 14×1.5	6	35	21	10	51	49.0	24	17	128	GMA3/08LOMD	315	315	4	4
	10	M 16×1.5	7	37	23	11	53	49.0	24	19	132	GMA3/10LOMD	315	315	4	4
	12	M 18×1.5	8	37	23	11	53	50.5	27	22	145	GMA3/12LOMD	315	315	4	4
	15	M 22×1.5	11	39	25	12	55	52.0	30	27	174	GMA3/15LOMD	315	315	4	4
	18	M 26×1.5	14	39	24	12	57	53.0	32	32	192	GMA3/18LOMD	315	315	4	4
	22	M 30×2.0	18	43	28	14	61	55.0	36	36	220	GMA3/22LOMD	160	160	4	4
	28	M 36×2.0	23	43	28	14	61	57.5	41	41	259	GMA3/28LOMD	160	160	4	4
	35	M 45×2.0	30	47	26	16	69	60.0	46	50	363	GMA3/35LOMD	160	160	4	4
	42	M 52×2.0	36	47	25	16	71	64.5	55	60	419	GMA3/42LOMD	160	160	4	4
S ⁴⁾	06	M 14×1.5	4	39	25	12	55	49.0	24	17	137	GMA3/06SOMD	630	630	4	4
	08	M 16×1.5	5	39	25	12	55	49.0	24	19	141	GMA3/08SOMD	630	630	4	4
	10	M 18×1.5	7	39	24	12	57	49.0	24	22	141	GMA3/10SOMD	630	630	4	4
	12	M 20×1.5	7	39	24	12	57	49.0	24	24	150	GMA3/12SOMD	630	630	4	4
	14	M 22×1.5	10	43	27	14	63	50.5	27	27	172	GMA3/14SOMD	630	630	4	4
	16	M 24×1.5	11	43	26	14	63	52.0	30	30	195	GMA3/16SOMD	400	400	4	4
	20	M 30×2.0	15	47	26	16	69	55.0	36	36	254	GMA3/20SOMD	400	400	4	4
	25	M 36×2.0	20	51	27	18	75	57.5	41	46	329	GMA3/25SOMD	400	400	4	4
	30	M 42×2.0	25	55	28	20	81	60.0	46	50	412	GMA3/30SOMD	400	400	4	4
	38	M 52×2.0	32	61	29	22	91	64.5	55	60	616	GMA3/38SOMD	315	315	4	4

**DF = Design Factor

¹⁾Pressure shown = item deliverable

³⁾L = light series; ⁴⁾S = heavy series

$$\frac{PN \text{ (bar)}}{10} = PN \text{ (MPa)}$$

Delivery without nut and ring.

Information on ordering complete fittings or alternative sealing materials see page 17.

*Please add the suffixes below according to the material/surface required.

Order code suffixes			
Material	Suffix surface and material	Example	Standard sealing material (no additional suffix needed)
Steel, zinc plated, Cr(VI)-free	CF	GMA3/06LOMDCF	NBR
Stainless Steel	71	GMA3/06LOMD71	VIT

VKA3 Test Point for cones with threaded connection M 16×2 Series 3

With 24° cone swivel nut connection

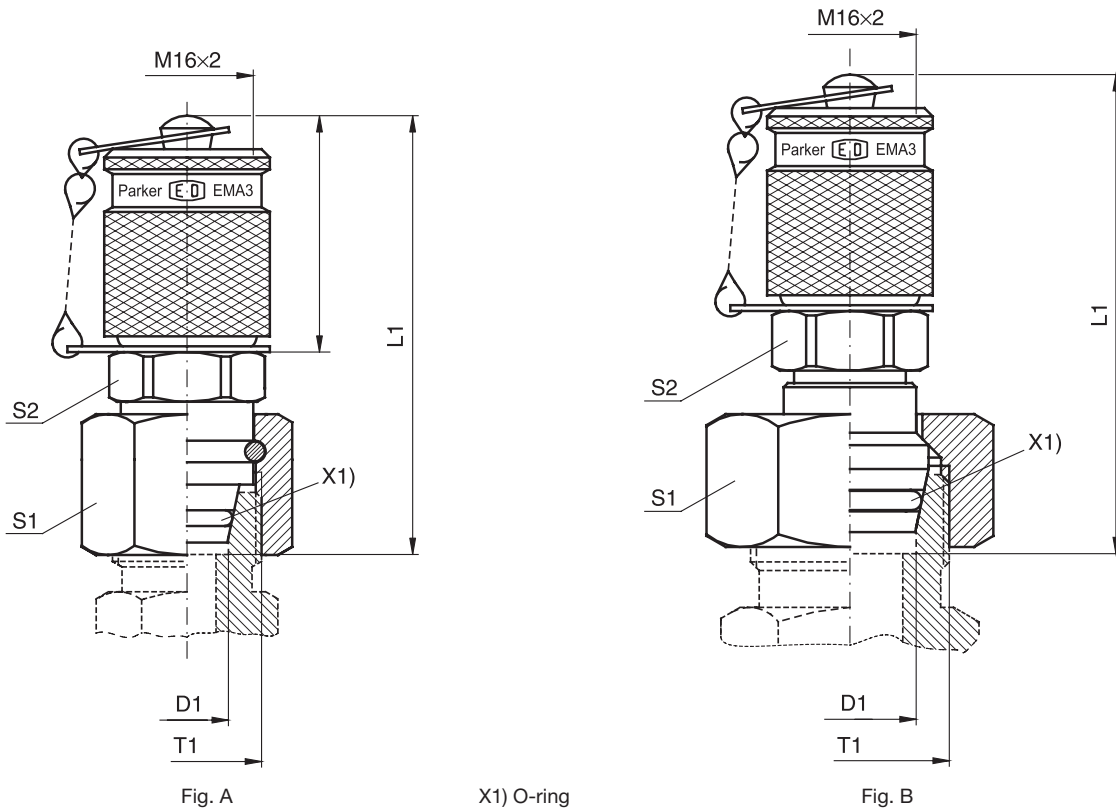

Fig. A

X1) O-ring

Fig. B

Series	D1	T1	L1	S1	S2	Fig.	Weight g/1 piece	Order code*	PN (bar) ¹⁾		DF**	
									CF	71	CF	71
L ³⁾	06	M 12×1.5	55	14	17	A	82	VKA3/06L	315	315	4	4
	08	M 14×1.5	51	17	17	A	82	VKA3/08L	315	315	4	4
	10	M 16×1.5	53	19	17	A	93	VKA3/10L	315	315	4	4
	12	M 18×1.5	53	22	17	A	107	VKA3/12L	315	315	4	4
	15	M 22×1.5	59	27	17	B	133	VKA3/15L	315	315	4	4
	18	M 26×1.5	59	32	17	B	163	VKA3/18L	315	315	4	4
	22	M 30×2.0	60	36	17	B	205	VKA3/22L	160	160	4	4
	28	M 36×2.0	64	41	17	B	269	VKA3/28L	160	160	4	4
	35	M 45×2.0	71	50	17	B	411	VKA3/35L	160	160	4	4
	42	M 52×2.0	72	60	17	B	592	VKA3/42L	160	160	4	4
S ⁴⁾	06	M 14×1.5	50	17	17	A	81	VKA3/06S	630	630	4	4
	08	M 16×1.5	52	19	17	A	88	VKA3/08S	630	630	4	4
	10	M 18×1.5	53	22	17	A	99	VKA3/10S	630	630	4	4
	12	M 20×1.5	54	24	19	A	121	VKA3/12S	630	630	4	4
	14	M 22×1.5	59	27	17	B	136	VKA3/14S	630	630	4	4
	16	M 24×1.5	58	30	17	B	156	VKA3/16S	400	400	4	4
	20	M 30×2.0	65	36	17	B	223	VKA3/20S	400	400	4	4
	25	M 36×2.0	68	46	17	B	367	VKA3/25S	400	400	4	4
	30	M 42×2.0	74	50	17	B	444	VKA3/30S	400	400	4	4
	38	M 52×2.0	81	60	17	B	655	VKA3/38S	315	315	4	4

**DF = Design Factor

¹⁾Pressure shown = item deliverable

³⁾L = light series; ⁴⁾S = heavy series

$$\frac{PN \text{ (bar)}}{10} = PN \text{ (MPa)}$$

*Please add the **suffixes** below according to the material/surface required.

Order code suffixes			
Material	Suffix surface and material	Example	Standard sealing material (no additional suffix needed)
Steel, zinc plated, Cr(VI)-free	CF	VKA3/06LCF	NBR
Stainless Steel	71	VKA3/06L71	VIT

MAV...MA3 Test point pressure gauge connector with threaded connection M 16×2

MAVMD...MA3 Test point with threaded connection M 16×2

SMA3 Test point high pressure hose with threaded connection M 16×2 Series 3

Female thread: BSP
Sealing: sealing ring DIN 16258*

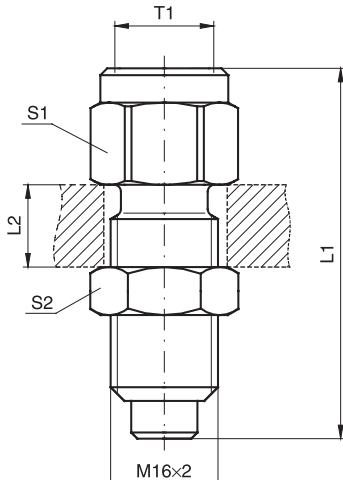

Pressure gauge connector:
MAV...MA3

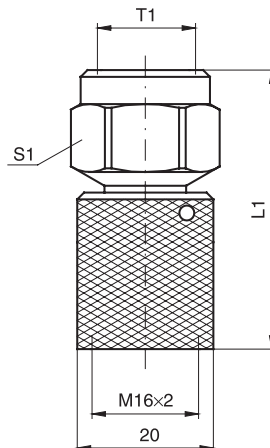

Gauge-Direct-Connector:
MAVMD...MA3

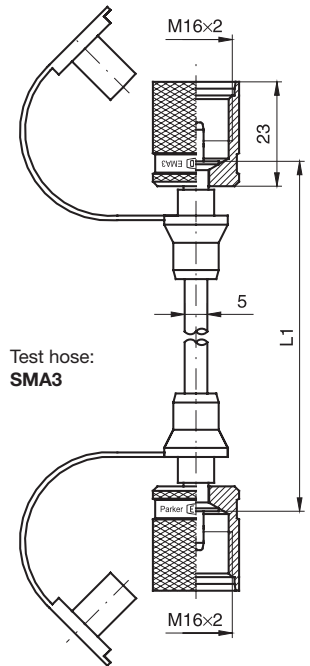

T1	L1	L2 max.	S1	S2	Weight g/1 piece	Order code*	PN (bar)1) CF	DF**
G 1/4	54.0	12	19	19	74	MAV1/4MA3	630	4.0
G 1/2	64.0	12	27	19	129	MAV1/2MA3	630	4.0
G 1/4	41.0		19		61	MAVMD1/4MA3	630	4.0
G 1/2	51.5		27		103	MAVMD1/2MA3	630	4.0
	200.0				73	SMA3-200	630	2.5
	300.0				74	SMA3-300	630	2.5
	400.0				74	SMA3-400	630	2.5
	630.0				79	SMA3-630	630	2.5
	800.0				83	SMA3-800	630	2.5
	1000.0				87	SMA3-1000	630	2.5
	1500.0				95	SMA3-1500	630	2.5
	2000.0				105	SMA3-2000	630	2.5
	2500.0				110	SMA3-2500	630	2.5
	3200.0				125	SMA3-3200	630	2.5
	4000.0				137	SMA3-4000	630	2.5

**DF = Design Factor

1) Pressure shown = item deliverable

$$\frac{PN \text{ (bar)}}{10} = PN \text{ (MPa)}$$

*Please add the **suffixes** below according to the material/ surface required.

Order code suffixes			
Material	Suffix surface and material	Example	Standard sealing material (no additional suffix needed)
Steel, zinc plated, Cr(VI)-free	CF	MAV1/4MA3CF	NBR

* Sealing rings according to DIN 16258 for steel design of copper, for stainless steel design of stainless steel.

Note hoses with small diameter:

- Min. bending radius $r = 20$ mm
- Working temperature -20 °C up to 100 °C (short time to $+120$ °C)
- Hoses are to be protected from fire, from sharp-corners and hot objects.

For measuring with liquid pressure media please note: Bleed before connecting tube! By capillary action discharge of the pressure medium is prevented widely.

Temperature factor of pressure rating:

up to 0 °C	122 %
for 30 °C	110 %
for 50 °C	100 %
for 80 °C	86 %
for 100 °C	77 %

ServiceJunior



The **ServiceJunior** enables the measurement and display of pressures in a single device. Thanks to the four-digit display, the measurement values are displayed more accurately. Pressure peaks are securely recorded with a sampling rate of 10 ms.

The **ServiceJunior** is characterized by its easy use. With its convincing price-performance ratio, the device offers all the advantages of digital pressure measurement. The measurement of MIN and MAX values enables pressure peaks to be recorded.

Device features:

- Digital pressure measurement and backlit display
- Accuracy $\pm 0.1-0.5$ % FS (FullScale)
- Display with a bar chart (drag indicator) using the peak hold function
- Pressure peak measurement with 10 ms sampling rate
- Easy operation
- Robust and reliable
- Rotating

Parker Serviceman Plus



The new **Parker Serviceman Plus** is a mobile, extremely robust and easy-to-use measurement instrument for numerous measurement tasks in mobile hydraulics and stationary hydraulic plants.

Thanks to the automatic sensor recognition, you can simply clip in pressure, temperature, flow rate and speed sensors and start measurements immediately. No tedious sensor parameterizing required, the measuring ranges are automatically scaled and the measurement unit is shown in the display.

Device features:

- Easy operation
- Robust design with oil-resistant rubber protection
- Plug-&-Play functionality
- Large back-lit display
- New storage concept with a Nano USB stick
- Incl. PC software SensoWin®
- Can be delivered in 2 versions: analog or CAN

The Parker Service Master *Easy*



The Parker Service Master *Easy* is a multi-channel portable measurement instrument for the simultaneous measurement of important hydraulic units:

It can measure, display, store and process all hydraulic parameters such as pressure, differential pressure, temperature, rotation speed, flow rate and hydraulic performance.

In order to meet the requirements of both modern industry hydraulics and complex mobile hydraulics, different versions are available to the user.

Device features:

- 3-channel and 4-channel versions
- Easy to use thanks to automatic sensor recognition
- PC connection
- Measuring channels
- Integrated memory
- Trigger storage
- Incl. PC software SensoWin®

The Parker Service Master *Plus*



In machine, plant and vehicle construction, the implementation possibilities of hydraulics are constantly increasing through the combination of hydraulics and electronics. The Parker Service Master *Plus* meets the demands of this development. It has never been easier to measure, display and analyze complex processes. The tried and tested storage process is particularly targeted at the measurement of MIN and MAX values and, in combination with various display options, offers analysis possibilities for problem solving.

Device features:

- Portable multi-function measuring instrument
- Measure, monitor and analyze pressure, temperature, volumetric flow rate and rotation speed.
- Measurements and displays from 26 sensors
- Presentation of measurement values as figures, bars, pointer and curves
- Project templates stored and loaded
- Interfaces: CAN, LAN, USB
- Storage of all measurement values for more than 1 billion values.
- Measurement data (automated recording, storage and analysis via LAN and USB with PC software SensoWin®)

PC software SensoWin®

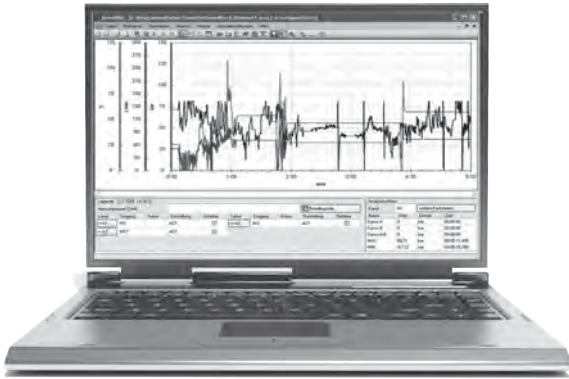

PC software **SensoWin®** is an easy-to-use aid for importing and editing the measurement curves recorded by the **Parker Serviceman Plus**, **The Parker Service Master Easy** or **The Parker Service Master Plus**.

Documentation and certificates are easily and cheaply issued, as PC software **SensoWin®** can serve all possibilities and advantages of Windows.

Device features:

- Easy operation
- Compatible with Windows 2000/XP/VISTA/7 (32- und 64-bit)
- Zoom function
- Conjunction of measurement curves
- Tabular view of measurement values
- Calculation of extreme values
- Cursor function
- Transmission of measurement procedures and documentation print-out
- Export function
- Online measurement

Test-Kit SCJN



Thanks to the **ServiceJunior-Test-Kit**, you can easily check manometers and pressure sensors, configure pressure switches and much more besides.

The Kit consists of a hand pump, with a choice of hydraulic or pneumatic, to produce a definite control pressure, and of a **ServiceJunior** as a reference device. Air, water and oil are used as pressure media.

Device features:

- Easy production of control pressures and adjustment of:
 - manometers
 - pressure sensors
 - pressure switches
 - safety valves
- Also suitable for portable use
- Pneumatic version from -0.95 - 60 bar and hydraulic version from 0 - 700 bar
- No additional power supply required
- Comprehensive adaptor set included

SCMA-FCU-600 Frequency Measurement

With the **SCMA-FCU-600** frequency signals such as turbines, flowmeters and speed sensors with a frequency output can be connected to our portable measuring instruments. Sinusoidal or squarewave signals from 1 Hz to 5 Hz can be processed with a signal amplitude of 40 mV to 10 V. Configuration through USB and PC software.

- **Power supply for external sensor**

With the **SCMA-FCU-600**, external sensors can be supplied with a voltage of 24 V.

- **Analog and CAN outlet**

The SCMA-FCU-600 can be connected to the analog or CAN input of our measuring instruments, as desired.

SCMA-VADC-600

Signals such as 0/4...20 mA or 0...10 V from other sensors e. g. for torque, force or displacement, can be connected to our portable measuring instruments

Applications:

- Force/displacement diagram
- Torque-volumetric flow rate characteristic curve

- **Current/voltage measurement**

Electric currents up to 4 ADC and voltage up to 48 VDC can be measured with this module.

Applications:

- Current consumption at proportional valve
- Measurement of switching states of motors/pumps

SCP Pressure Measurement - Analog

SCP Pressure Measurement - CAN



Quick response times guarantee a quick identification of disturbing pressure peaks in the hydraulic system. The robust stainless steel construction allows a variety of applications, e. g. in hydraulics, for cooling water or in compressed air systems.

All pressure sensors are delivered with pre-assembled diagnosis adaptors (M16x2). The connection to the hydraulic system is quick and secure. Reduced assembly times.

Device features:

- Small size
- Robust stainless steel design
- Response time of 1 ms
- Pressure peaks logged
- Accuracy ± 0.5 %

All the advantages of the analog SCP sensors combined with future-proof CAN bus technology. Simple wiring with the quick plug/screw connection SPEEDCON®. Plug-&-Play functionality with minimum configuration effort.

All pressure sensors are delivered with pre-assembled diagnosis adaptors (M16x2). The connection to the hydraulic system is quick and secure. Reduced assembly times.

Device features:

- Small size
- Robust stainless steel design
- Response time of 1 ms
- Pressure peaks logged
- Accuracy ± 0.5 %
- Quick plug/screw connection SPEEDCON®
- Sensor identification light ring
- Suitable for long cable lengths

SPEEDCON® Registered trademark of the PHÖNIX CONTACT GmbH & Co company. KG

SCPT Pressure/Temperature Measurement - Analog

SCPT Pressure/Temperature Measurement - CAN



Quick response times guarantee a quick identification of disturbing pressure peaks in the hydraulic system. The robust stainless steel construction allows a variety of applications, e. g. in hydraulics, for cooling water or in compressed air systems.

All the advantages of the analog SCPT sensors combined with future-proof CAN bus technology. Simple wiring with the quick plug/screw connection SPEEDCON®. Plug-&-Play functionality with minimum configuration effort.

All pressure sensors are delivered with pre-assembled diagnosis adaptors (M16X). The connection to the hydraulic system is quick and secure. Reduced assembly times.

All pressure sensors are delivered with pre-assembled diagnosis adaptors (M16x2). The connection to the hydraulic system is quick and secure. Reduced assembly times.

Device features:

- Robust stainless steel design
- Response time of 1 ms
- Pressure peaks logged
- Accuracy ± 0.5 %

Device features:

- Robust stainless steel design
- Response time of 1 ms
- Pressure peaks logged
- Future-proof CAN bus technology
- Simple wiring with SPEEDCON®
- Sensor identification LED
- Suitable for long cable lengths
- Accuracy ± 0.5%



SCT Temperature Measurement - Analog

SCT Temperature Measurement - CAN



Temperature measurements in hydraulics are useful for searching for faults and for avoiding damage following too high temperatures in critical components such as pumps or proportional valves.

In order to carry out a precise temperature measurement, the temperature is measured directly in the pipe or hose line.

The insertion sensors of the SCT-190 series can also be used to measure temperature in SCFT-xxx-02-02 turbine flowmeters.

Device features:

- High pressure-resistant temperature probe
- Temperature measurement up to 1000°C
- Flexible use
- Pressure peaks logged
- Screw-in or bulb sensor

Temperature measurements in hydraulics are useful for searching for faults and for avoiding damage following too high temperatures in critical components such as pumps or proportional valves.

In order to carry out a precise temperature measurement, the temperature is measured directly in the tube or hose line.

The insertion sensors of the SCT-190 series can also be used to measure temperature in SCFT-xxx-02-02 turbine flowmeters.

Device features:

- High pressure-resistant temperature probe for measuring hydraulics
- Temperature measurement up to 150°C
- Flexible use
- Insertion sensor
- Sensor identification light ring
- Accuracy ± 0.66 %
- Quick plug/screw connection SPEEDCON®
- Suitable for long cable lengths

SCRPM Speed Measurement - Analog



Performance data that depends on the rotation speed, such as the delivery rate of regulated pumps, are ideally transmitted along with the pressure and the flow rate measurement of a hydraulic drive.

Contactless speed measurement (optoelectronic principle) is fast and easy to implement.

The rotation speed is measured, e. g. at a drive shaft, and shown on the measuring instrument. No adjustment needed.

Device features:

- Also for contactless rotation speed measurement
- Speed measurements up to 10,000 RPM
- With 3-m fixed cable

SCFT Turbine Flowmeter - Analog



A turbine wheel is driven by the oil flow and thus set in motion. The frequencies produced are processed by a digital electronic device. The influence of disturbing flow effects is thus compensated. With the lower flow resistance Q_R , the hydraulic circulation operates at low loss.

The turbine flowmeter is equipped with an EMA-3 quick connect coupling to measure the pressure. Oil temperatures can be directly measured from the oil flow in the turbine flowmeter. Thus, all the important measured values are gathered in one location.

Device features:

- 6 measuring ranges up to 750 l/min
- Easy assembly
- Resistant to high pressure up to 480 bar
- Low flow resistance
- Integrated pressure and temperature measurement points
- Suitable for reverse mode

SCFTT CAN Turbine Flowmeter



A turbine wheel is driven by the oil flow and thus set in motion. The frequencies produced are processed by a digital electronic device. The influence of disturbing flow effects is thus compensated. With the lower flow resistance Q_R , the hydraulic circulation operates at low loss.

The turbine flowmeter is equipped with an EMA-3 quick connect coupling to measure the pressure.

Oil temperatures are directly measured from the oil flow in the turbine flowmeter. Thus, all the important measured values are gathered in one location.

Device features:

- Turbine flowmeter with integrated temperature sensor in CAN bus technology
- 6 measuring ranges up to 750 l/min
- Easy assembly
- Resistant to high pressure up to 480 bar
- Low flow resistance
- Integrated pressure and temperature measurement points
- Suitable for reverse mode
- Simple wiring with SPEEDCON®
- Suitable for long cable lengths
- Sensor identification LED

SCLV Hydraulics Tester - Analog and CAN



Hydraulics testers test the functions of motors, pumps, valves, and hydrostatic drives. These easy-to-handle hydraulic testers can help locate faults in a hydraulic system.

Hydraulic testers can be used for a precise measurement of pressure, temperature, and flow rate when performing maintenance work on hydraulic systems and to locate the source of faults in regulated directional control valves and in the placement of valves.

The pressure loading valve with integrated bursting discs allows pressure to build up progressively to test the flow rate over the whole work area.

Device features:

- 2 measuring ranges up to 750 l/min
- Resistant to high pressure up to 480 bar
- Integrated overload protection
- Reverse mode (flow direction A-B)
- Also with a CAN bus connection
- CAN version with integrated temperature sensor
- Connections for pressure and temperature sensors possible

SCQ Flowmeter - Analog



In high pressure hydraulics, a rapid identification of the rate of flow is very important. Thanks to the quick response time of the flowmeter, the dynamic behavior of hydraulic systems can be measured.

The direction indicator is helpful when searching for faults in the hydraulic system.

Quick load changes that cause damage, for example, to valves or pumps, can be identified. Assembly with the connector block allows the combined measurement of p, T, and Q. The IN-LINE adaptor for pipe or hose assembly ensures the quick integration of the flowmeter into the hydraulic system. The robust construction also permits application in extreme conditions, such as a high load change or speeds of pressure increase.

Device features:

- Spring/piston system
- Flowmeter with direction indicator
- Response time ≤ 2 ms
- Compact construction
- Pressure-resistant up to 420 bar
- Wide range of viscosity
- p, T, and Q measurements possible with connector block

SCVF Volume Counter



The **SCVF** is a volume counter for highly accurate flow measurements in hydraulic installations. A very precisely worked gear pair is driven by the fluid flow.

The **SCVF** works in a wide range of viscosity. Different thicknesses allow a variety of applications.

Thanks to the wide range of viscosity, all pumpable fluids with a certain degree of lubricity can be measured:

- mineral oils
- hydraulic oils
- grease
- brake fluid (EPDM sealing)
- Skydrol (special version)

If you need to gather exact flow measurements from a wide range of viscosity, the **SCVF** volume counter is the ideal solution.

Device features:

- Measurement principle: volume/gear counter
- 4 measuring ranges up to 300 l/min
- Measurement accuracy ± 0.5 % FS
- Pressure-resistant up to 400 bar
- Wide range of viscosity
- Quiet
- Exact flow measurement over a wide range of viscosity
- Flexible use of different media

SCPSDi Pressure Switch



The **SCPSDi** is an electronic pressure switch with:

- Pressure display
- 2 programmable switching outputs
- Optional analog output signal
- IO-link interface
- VDMA menu navigation

The new construction concept and the resulting assembly possibilities combined with multiple connection options are the most important characteristics of the **SCPSDi**.

This unique scope of functions makes the **SCPSDi** ideal for long-term series use in industrial applications.

Device features:

- IO-Link
- VDMA menu
- ECO Mode
- Rotating >360°
- 180° reversible display
- Analog output V/mA
- Reliable operation thanks to LOCK
- Compact
- Robust
- MPa, bar, PSI
- Metal housing
- Mounting width 35 mm
- Mounting height 78 mm

Controller Family

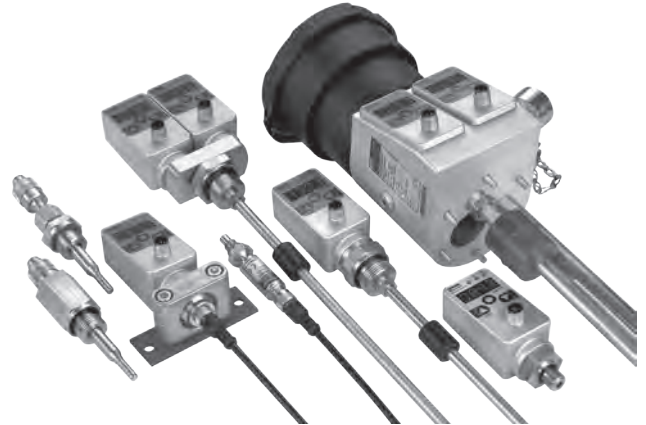

Controllers are used in control, management, and monitoring systems in which switch or analog signals or a display is/are necessary.

The controllers can replace:

- mechanical switches
- mechanical displays (manometers, thermometers, gauge-glasses)
- sensors

and combine all the functions of the above-named components in a single device.

Device features:

- Large display
- Freely adjustable
- Robust metal design
- Compact
- Long term stability
- Reliable
- Resistant to interference

SCPSD PressureController



The PressureController combines the functions of a pressure switch, a pressure sensor, and a display unit:

- Pressure display (manometer)
- Switching outputs
- Analog signal

Simple operation, compact construction and high reliability are the most important characteristics of the PressureController. The PressureController offers exceptional technical data and optimum pressure management, combined with various assembly options. It is therefore ideal for long-term series use in industrial applications.

Each switching output can be configured individually:

- Normally open/normally closed contact
- On/off switching pressures
- Delay times
- Hysteresis/window function
- Attenuation

These comfortable switch functions enable intelligent configurations which are not possible with mechanical switches. Thus, several switches can be replaced by a single controller.

Device features:

- Compact
- Robust
- Reliable
- Easy operation
- Long term stability
- Excellent interference resistance
- Metal housing
- High protection class
- Many versions
- Rotating
- Analog output
- Password
- MPa, bar, PSI



Catalogue 4083

SCTSD TemperatureController

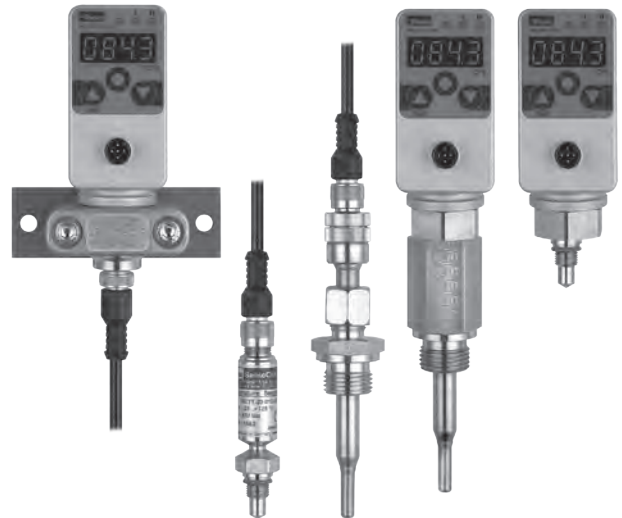

The TemperatureController combines the functions of a temperature switch, a temperature sensor, and a display unit:

- Temperature display (thermometer)
- Switching outputs
- Analog signal

Simple operation, varied functionality, and a modular design are the most important characteristics of the TemperatureController. The TemperatureController offers exceptional technical data and optimum temperature management, combined with various assembly options. It is therefore ideal when the temperature must be safely monitored and clearly displayed.

Each switching output can be configured individually:

- Normally open/normally closed contact
- On/off switching pressures
- Delay times
- Hysteresis/window function
- Time delay

These comfortable switch functions enable intelligent configurations which are not possible with mechanical switches. Thus, several switches can be replaced by a single controller.

Device features:

- Compact
- Robust
- Reliable
- Metal housing
- Modular design
- Many versions
- Analog output
- Rotating
- Password
- °C, °F



Catalogue 4083

R

SCTSD-L Combination Switch



The **SCTSD-L** combination switch was devised around the requirements of hydraulic unit constructions and combines the functions of a fixed mechanical level switch with those of a configurable electronic temperature switch with a display.

Level

The tank level is measured by a highly dynamic and fully encapsulated magnetic float and switches the bistable dry reed contacts. The M12 pin assignment is compatible with conventional systems. The level contacts are firmly preset according to normal tank sizes. Two standard switching output versions are available.

Temperature

The temperature is measured via the temperature sensor and assessed by the SCTSD TemperatureController and continually displayed. These comfortable switch functions (e. g. window function) enable intelligent configurations which are not possible with mechanical temperature switches.

Device features:

- Compact construction
- Temperature display
- Individually configurable temperature switch outputs
- Small switching hysteresis
- Preset
 - for standard oils
 - for cooling
 - for shutdown (T_{max})
- Fixed level contacts
- Bistable contacts
- Preset level
 - Warning and shutdown min
 - Shutdown min/max
- Up to 1 m bar length



Catalogue 4083

SCLTSD LevelTempController



The LevelTempController enables the temperature and the level to be configured and displayed separately on the same platform. When monitoring the tank, this integration of level and temperature functionality opens up many possibilities.

The LevelTempController combines the functions of a level/temperature switch, a level/temperature sensor, and a level/temperature display:

- Level/temperature display
- Switching outputs
- Analog signal

Level

The position of the float is finely graduated (≥ 5 mm) and continually logged and shown in mm or inches in the display. The continual logging of the level means that there is no risk of individual mechanical contacts 'sticking'. This greatly increases the operational safety of the monitored installation.

Temperature

The temperature in the medium is continually logged and shown on the display. As with the LevelController, all switching outputs can be configured individually. In addition, all the comfortable switching functions are available, including the window and hysteresis functions, normally open and normally closed contacts, and an analog output for temperature.

Device features:

- Proven measurement system
- Rotating
- Level display
- mm/inch/% display
- High & low display
- Analog output
- Switching outputs
- One borehole only
- No surge pipe necessary
- Replaces several mechanical switches



Catalogue 4083

SCLSD LevelController



The LevelController combines the functions of a level switch, a level sensor, and a level display:

- Level display (gauge-glass)
- Switching outputs
- Analog signal

The LevelController is best suited for monitoring tank levels.

A variety of applications can be comfortably implemented or subsequently corrected through the menu-driven configuration of the level switching points. As the switching points no longer need to be given when ordering, the usual variability found in mechanical level switches is reduced.

Each switching output can be configured individually:

- Normally open/normally closed contact
- Higher/lower level switching point
- Delay times
- Hysteresis/window function
- Attenuation

These comfortable switch functions enable intelligent configurations which are not possible with mechanical switches. Thus, several switches can be replaced by a single controller.

Device features:

- Proven measurement system
- Level display
- mm/inch/% display
- High & low display
- Analog output
- Switching outputs
- No surge pipe necessary
- Replaces several mechanical switches
- Rotating



Catalogue 4083

SCOTC OilTankController



In addition to the LevelTempController, the OilTankController offers standardized connections for an air filter and a filling coupling.

When monitoring the tank for series use, this integration of level and temperature functionality together with air filter and fill adapter port opens up many possibilities. Only one connecting bore is needed for four functions.

The OilTankController combines the functions of a level/temperature switch, a level/temperature sensor, and a level/temperature display:

- Level/temperature display (Thermometer/gauge-glass)
- Switching outputs
- Analog signal

Each switching output can be configured individually:

A variety of applications can be comfortably implemented or subsequently corrected through the menu-driven configuration of the level switching points. As the switching points no longer need to be given when ordering, the usual variability found in mechanical level switches is reduced.

Device features:

- Proven measurement system
- Level/temperature display
- mm/inch/% display
- High & low display
- One borehole only
- Continual level measurement
- Connection
 - Filling coupling
 - Air filter
 - Negative pressure
- No surge pipe necessary



Catalogue 4083

SCP01 Pressure Sensors



The **SCP01** pressure sensor was designed for the requirements of industrial applications and is used for control, management, or monitoring systems. The **SCP01** is characterized by its compact form, high linearity, and excellent interference resistance. Thanks to its speed of response, the **SCP01** is also used for rapid control processes. The compact stainless steel housing is designed for harsh ambient conditions. All parts in contact with the medium are manufactured from stainless steel and, in combination with welded thin-layer measuring cell, ensure high medium compatibility. All electronic parts are encapsulated as protection against vibrations and humidity.

An EDM hole is integrated in order to ensure an exact pressure measurement free from interference. It minimizes air cavitation and thus protects the measuring cell from any pressure blows or pressure peaks that may occur.

Thanks to its long life, high accuracy, high reliability, and robust stainless steel construction, it is the device best suited for sustained series use in hydraulic applications.

Device features:

- Small construction
- Stainless steel measuring cell
- Stainless steel housing
- Resistant to shock and vibrations
- Wide-ranging media compatibility
- High linearity
- Long term stability
- Medium temperature -40 ... 125 °C
- Up to 1000 bar
- High burst pressure
- 1 ms
- EDM-drilling
- Encapsulated electronic parts

Catalogue 4083

Pressure sensors SCP02



The **SCP02** was specially designed for use in mobile work machines. For this, the **SCP02** has received e1 approval and is manufactured with the latest manufacturing methods, in accordance with ISO/TS 16949.

Its resistance to shock and vibrations, EMC properties, power supply, and wider temperature range have been designed for this area of application.

Thanks to its speed of response, the **SCP02** can also be used for rapid control processes.

The compact stainless steel housing and the plastic plug enable use in harsh ambient conditions, such as are found in mobile hydraulics.

All parts in contact with the medium are manufactured from stainless steel (1.4548) and, in combination with the welded thin-layer measuring cell, ensure high medium compatibility.

An EDM hole is integrated in order to ensure an exact pressure measurement free from interference. It minimizes air cavitation and thus protects the measuring cell from any pressure blows or pressure peaks that may occur.

Device features:

- Small construction
- Stainless steel measuring cell
- Stainless steel housing
- Resistant to shock and vibrations
- High degree of protection
- E1 road approval
- Medium temperature -40 ... 150 °C
- Up to 1000 bar
- 1 ms
- Up to 36 V wiring systems



Catalogue 4083

SCPS01 Pressure Switch



The **SCPS01** electronic pressure switch was conceived for use in series machines.

In order to make assembly more straightforward, the pressure switches can be pre-programmed to client-specific values upon request. Time-consuming adjustments or configuration under pressure are therefore unnecessary. The system manufacturer can configure the pressure switches by software. This excludes the possibility of an unauthorized end user manipulating the switch.

The pressure switches do not contain any mechanical moving parts. All parts in contact with the medium are made out of stainless steel and, in combination with the welded thin-layer measuring cell, ensure high medium compatibility. A cushioning mechanism can be optionally integrated in the medium inlet. The stainless steel housing enables use in extremely harsh ambient conditions.

In order to ensure a wide field of use, the EMC properties and shock and vibration resistance are configured for use in mobile work machines. The e-1 approval even permits the **SCPS01** to be installed in vehicles used on public roads.

Thanks to their robust and compact construction, combined with their long-term stability and attractive price, the **SCPS01** are the alternative to mechanical pressure switches.

Device features:

- Long life
- No re-adjustment
- Engineered for harsh environments
- Precise switching



Catalogue 4083

SCP-EX Pressure Sensors



The **SCP-EX** can be configured for Zone 1 and conforms with Directive 94/9/EC. Thanks to the appropriate protective circuits, polarity reversal protection, overvoltage protection, and power dissipation limitation will be activated in the case of a fault. Its wide-reaching industrial application options are guaranteed through high accuracy and a robust and compact construction.

Various pressure transducers are available thanks to its compatibility with different mechanical and electrical connections.

For Zone 1, in which explosive atmospheres, such as a mix of inflammable compounds in the form of gas, steam, or haze and air, sometimes occur in normal operation. It is essential to adhere to the relevant national safety regulations when assembling, commissioning, and operating these pressure transducers.

Device features:

- Measuring ranges 0 ... 1000 bar
- ATEX approval for Zone 1
 - II 2G Ex ia IIC T4
- Output signal 4 ... 20 mA
- High reliability

R

Catalogue 4083

SCT-150 Temperature Sensors



A compact construction and high pressure resistance characterize the **SCT-150** electronic temperature sensor.

If the temperature needs to be measured under high pressure and a compact construction is necessary, the **SCT** can be used.

Thanks to its pressure resistance up to 630 bar, the **SCT** temperature sensor is suited to the needs of hydraulic applications.

It performs precise and quick temperature measurements.

The temperature sensors in the **SCT** series are compatible with the **SCE** panel measuring instruments. This allows the medium temperature as well as the hydraulic pressure to be measured, controlled, and evaluated.

Device features:

- Pressure-resistant up to 630 bar
- Compact construction
- Robust steel housing
- Easy assembly
- -25 °C ... +100 °C

SCE-020 Digital Display Unit



Multiple connections, a flexible display and numerous outlets characterize the **SCE** digital display unit. The **SCE-020** converts analog standard signals (in 0 ... 10 V to 0/4 ... 20 mA ranges) into easily understood measurement values/units.

Thus, the **SCE-020** can easily display any sensor (pressure, temperature, torque, length etc.) desired.

The display can be read from a great distance. In order to present different measuring values, the desired measurement range and the decimal point can be set easily and in a user-friendly way. Additional units are shown on a separate illuminated surface. The power supply can range from 11 to 30 VDC. An adjustable limit value can be monitored through the potential-free switching output. The analog output and the RS232 series interface can forward the signal to a corresponding peripheral device. If different measuring values need to be presented easily and in a flexible manner, the **SCE-020** display unit can be used.

Device features:

- Easily readable digital display:
 - large
 - bright
- Programmable
- Free choice of unit
- Input:
 - current 0/4 ... 20 mA
 - voltage 0 ... 10 V
 - frequency 0 ... 8 kHz
- Switching output
- Loophrough function:
 - analog output
 - series interface
- Standard housing 96 x 48 mm

Catalogue 4083

Catalogue 4083

SCK Cable



SensoControl® cables are designed according to the requirements of industrial sensors and switches.

M12 cables and M12 plugs are therefore usually

- compact
- screened
- 5-pin

5-pin design

The 5-pin cables are suitable for both 4 and 5-pin connections. 5-pin cables are fully compatible with sensor versions with 4-pin plugs.

This means that a (5-pin) cable design can always be used for pressure switches (Controller Family SCxSD & SCOTC) and sensors irrespective of the plug version and the different number of pins.

The SCK-400-xxx-x5 cables are compatible with all components with M12 plug connections.

Shielding

The screening ensures high interference resistance and operational safety.

- High EMC protection

Device features:

- One cable for everything
- Compact
- Resistant to interference
- Compatible with:
 - sensors
 - controllers
- M12 plugs
- DIN EN 175301 (connector plugs)
- Different lengths

Catalogue 4083

Dry Technology



**EO[®] Ermeto Original
Tubes**

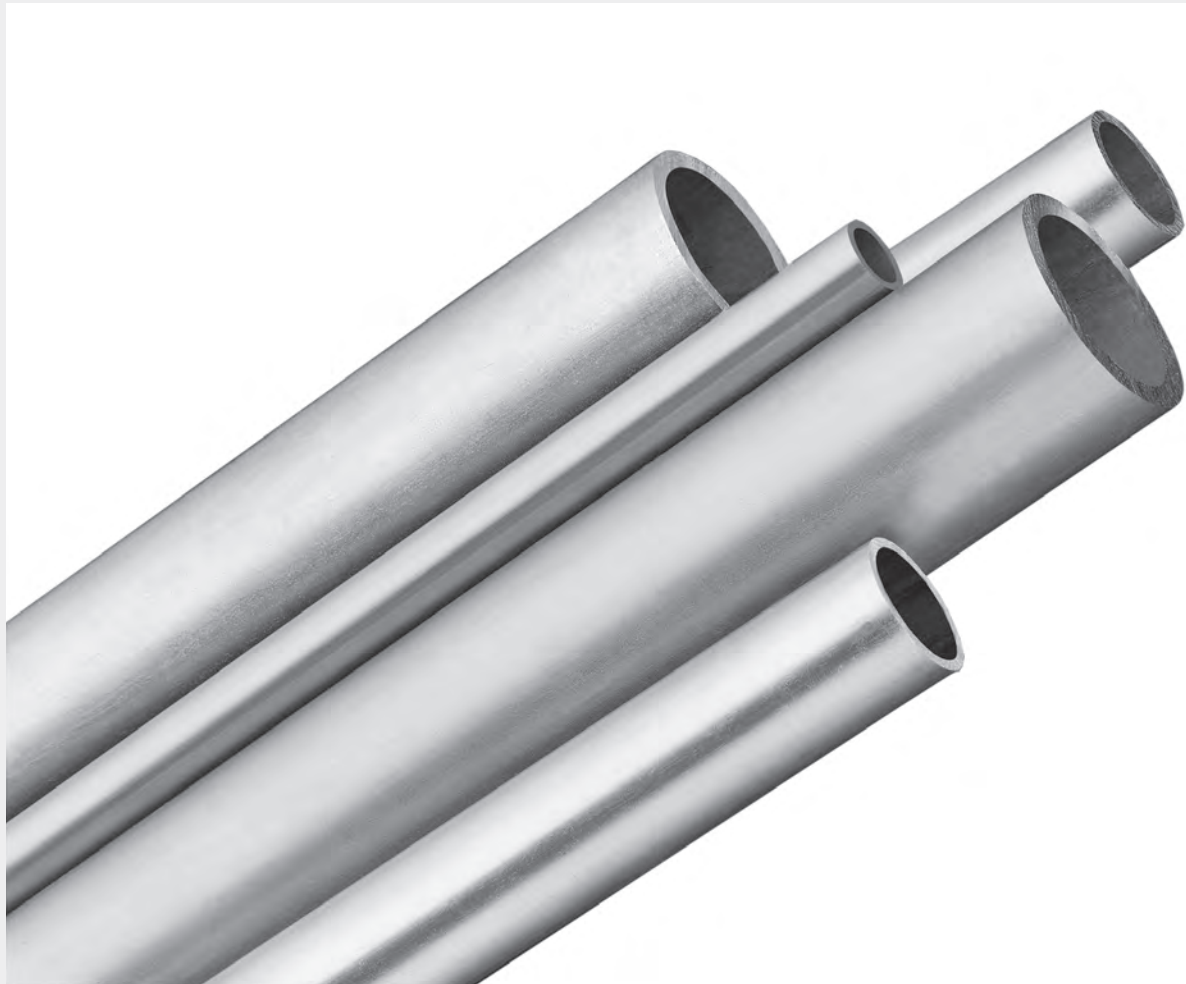



General recommendations for tubes

1. Steel types, mechanical properties, conditions

Steel types, mechanical properties and conditions of EO steel tubes

Steel type	Tensile strength Rm	Yield point ReH	Ductile yield A5 (longit.)	Condition
Fine grain E235N acc. to EN 10305-4 (St. 37.4 acc. to DIN 1630/DIN 2391 old designation)	340 N/mm ² min. 49,000 lb/in ²	235 N/mm ² min. 34,000 lb/in ²	25% min.	Seamless, cold drawn, normal annealed, DIN EN 10305-1 and -4

Steel types, mechanical properties and conditions of EO stainless steel tubes

Steel type	Tensile strength Rm	Yield point (1% proof stress)	Ductile yield A5 (longit.)	Condition
1.4571 X6CrNiMoTi17122	500 N/mm ² min. 72,500 lb/in ²	245 N/mm ² min. 35,500 lb/in ²	35% min.	Seamless, cold drawn free of scale, heat treated in accordance with DIN EN 10216-5 tab. 6

2. Tests and certifications

All tubes are subjected to a non-destructive leak test and marked accordingly as proof. This marking replaces a works certificate DIN EN 10204-2.2. Test class 1 DIN EN 10216-5 Table 7 applies for tubes made of 1.4571.

3. Recommended bend radius

A bend radius of 3x the external tube diameter is recommended for cold bending of tubes with tube benders or by hand.

4. Welding suitability and weldability

Tubes of E235N are weldable according to usual techniques. Types made of 1.4571 (stainless) are suitable for arc welding. The welding filler should be selected in accordance with DIN EN 1600 and DIN EN 12072 part 1 taking into account the type of application and the welding technique.

5. Approximate calculation of the flow resistance in straight tubelines

The flow resistance and thus the tubeline efficiency is influenced by the tube inside diameter, the volume flow (measured or calculated) and the properties of the medium. Laminar flow should be considered in order to keep losses in the system down to a minimum. The transition from laminar to turbulent flow, which brings an increase in the flow resistance is generally defined by the Reynolds number Re 2320. Since the transition cannot be pinpointed exactly, the transition range can only be determined by measuring. If, for simplified calculation, transition at Re 2320 and a "technically smooth" tube inner surface are assumed, the limit speeds $w_{crit.}$ and the laminar to turbulent flow volume flow $\dot{V}_{crit.}$ when transition takes place, can be estimated according to the following formulas:

$$w_{crit.} = \frac{2.32 \cdot \nu}{d_i} \quad [\text{m/s}]$$

$$q_{v, crit.} = 0.109 \cdot d_i \cdot \nu \quad [\text{l/min}]$$

d_i = tube bore Ø in mm

ν = kinematic viscosity in mm²/s

For approximate calculation of the pressure drop in bar/1 m tube length, the following formulas can be used:

1. Laminar range:

$$\rho_v = \frac{0.32 \cdot w \cdot \nu \cdot \rho}{d_i^2 \cdot 10^3} = \frac{6.79 \cdot q_v \cdot \nu \cdot \rho}{d_i^4 \cdot 10^3} \quad [\text{bar/1 m}]$$

2. Turbulent range:

$$\rho_v = \frac{0.281 \cdot w^{1.75} \cdot \nu^{0.25} \cdot \rho}{d_i^{1.25} \cdot 10^3}$$

$$= \frac{59 \cdot q_v^{1.75} \cdot \nu^{0.25} \cdot \rho}{d_i^{4.75} \cdot 10^3} \quad [\text{bar/1 m}]$$

w = flow speed in m/s; ν = kinetic viscosity in mm²/s; q_v = volume flow in l/min.; ρ = density of the medium in kg/m³; d_i = pipe internal diameter in mm.

Detailed calculations of the flow resistance require an exact knowledge of the tubeline system and the operating conditions. Refer to the relevant literature for other methods of calculations.

Tube and pipe specification

Recommended carbon steel tubes and pipes

Parker recommends the use of cold drawn seamless and regular annealed (abbreviation +N) hydraulic tubes and pipes acc.:

DIN-EN 10305 (old DIN 2391) and ISO 3304

For the assembly of steel fittings, steel tubes made of material E235 (ST37.4 +N) and E355 (ST52.4 +N) are recommended.

- | | |
|-----------------------------|--|
| + precision dimension/shape | + clean inside (no scale) |
| + high pressure capability | + excellent scaling surface after roll flaring |

Recommended stainless steel tubes and pipes

Parker recommends the use of seamless cold drawn stainless steel tubes and pipes acc. to:

DIN EN 10216-5, ASTM A269/A213, ASTM A312.

EO precision stainless steel tube meets and exceeds these standards. The tolerances of the pipe outer diameter and wall thickness are even closer to ensure a safe interplay with our fitting systems.

For the assembly of stainless steel tube fittings, EO precision stainless steel tubes made of material 316 Ti and 316L are recommended.

- | | |
|-----------------------------|--|
| + precision dimension/shape | + excellent scaling surface after roll flaring |
| + high pressure capability | |

Welded tubes and pipes

Tubes and pipes acc. to below specification but welded and cold redrawn instead of seamless drawn are usually suitable. Pressure capability might be reduced due to the welding seam zone.

Welding seam quality might effect roll flaring surface results.

Hot rolled pipes

Hot rolled pipes are not recommended for the following reasons:

Hot rolled pipes do not have precision dimensions and may slip in machine dies.

They have scales inside and outside. The inside scales effect the cleanliness level of the fluid and reduces fatigue levels. Used in roll flaring process the scales will contaminate the flaring tools (high cleaning effort) and cause poor flare surface quality.

The required maximum working pressure is calculated either acc. to DIN or DNV.

Material specifications & values

E235+N / St.37.4 (1.0308) acc. to DIN EN 10305-4

Tensile strength	min. 340 N/mm ²
Yield strength	min. 235 N/mm ²
Fatigue strength	225 N/mm ² ¹⁾
Elongation at break	min. 25%

E355+N / St.52.4 (1.0580) acc. to DIN EN 10305-4

Tensile strength	min. 490 N/mm ²
Yield strength	min. 355 N/mm ²
Fatigue strength	265 N/mm ² ²⁾
Elongation at break	min. 22 %

316Ti (1.4571) cold drawn (CFA) acc. to DIN EN 10216-5

Tensile strength	min. 500 N/mm ²
0.2 % proof stress	min. 210 N/mm ²
1 % proof stress	min. 245 N/mm ²
Fatigue strength	220 N/mm ² ²⁾
Elongation at break	min. 35 %

316L (1.4404) cold drawn (CFA)³⁾ acc. to DIN EN 10216-5

Tensile strength	min. 500 N/mm ²
0.2 % proof stress	min. 210 N/mm ²
1 % proof stress	min. 245 N/mm ²
Elongation at break	min. 35 %

316L (1.4404) acc. to ASTM A269 / A213

Tensile strength	min. 530 N/mm ²
Yield strength	min. 276 N/mm ²
0.2 % proof stress / 1.6 ⁴⁾	172.5 N/mm ²

316L (1.4404) acc. to ASTM A312 / A530

Tensile strength	min. 515 N/mm ²
Yield strength	min. 234 N/mm ²
0.2 % proof stress / 1.6 ⁴⁾	146 N/mm ²

¹⁾ DIN 2413, 6.331

²⁾ No standard value, Experience value

³⁾ Strength increase due to cold forming following 1.4571

⁴⁾ Pressure rating calculation based on this mechanical properties require certification according to 3.1 - EN 10204 that confirms the mechanical properties.

Tube calculation for industrial and mobile applications acc. to DIN rules

DIN 2413 I, only for static load

Calculation of working pressure of steel tubes for static stress up to 120°C. Corrosion - additional allowances are not considered for the calculation of pressures. Tubes with a diameter of OD/ID > 2 are calculated for static stress in accordance with DIN 2413 III, but with K = yield strength.

$$P = \frac{20 * K * s * c}{S * D}$$

- P = permissible working pressure [bar]
- K = yield strength [N/mm²]
- s = tube wall thickness [mm]
- c = factor for wall thickness allowance
 - = 0.8 for Tube-OD 4-5
 - = 0.85 for Tube-OD 6-8
 - = 0.9 from Tube-OD 10
 - = 0.9 for all stainless steel tubes
- S = Safety factor = 1.5
- D = tube outside diameter [mm]

DIN 2413 III, for dynamic load

Calculation of working pressure of steel tubes for dynamic stress up to 120°C. Corrosion - additional allowances are not considered for the calculation of pressures.

$$P = \frac{20 * K * s * c}{S * (D + s * c)}$$

- P = permissible working pressure [bar]
- K = fatigue strength [N/mm²]
- s = tube wall thickness [mm]
- c = factor for wall thickness allowance
 - = 0.8 for Tube-OD 4-5
 - = 0.85 for Tube-OD 6-8
 - = 0.9 for Tube-OD 10-80
 - = 0.9 for all stainless steel tubes
- S = safety factor = 1.5
- D = tube outside diameter [mm]

Burst pressure calculation

Calculation of static burst pressure for seamless tubes acc. to Faupel-von-Mises.

$$BP = R_{p0.2} * 10^{\frac{2}{3}} * \ln \frac{D}{d} * (2 - \frac{R_{p0.2}}{R_m})$$

- BP = Min. static burst pressure [bar]
- R = tensile strength [N/mm²]
- R_{p0.2} = 0.2% proof stress, yield strength [N/mm²]
- D = Tube outside diameter [mm]
- d = Tube inside diameter [mm]

Tube calculation for marine and offshore acc. to DNV rules

Calculation of working pressure of steel and stainless steel tubes for ship building acc. to DNV Part 4, Chapter 6, Section 6.

$$P = \frac{20 * \sigma_t * e * t_0}{D - t_0}$$

- P = permissible working pressure [bar]
- BP = approximate burst pressure [bar]
- σ_t = permissible stress [N/mm²]
calculated from the lower value off:

t₀ = tube wall thickness without allowances [mm]

- t_n = tube wall thickness nominal [mm]
- a = factor for wall thickness allowance
 - = 0.8 for Tube-OD 4-5, 0.85 for Tube-OD 6-8, 0.9 for Tube-OD >=10
 - = 0.875 for Schedule Pipes
 - = 0.9 for all stainless steel tubes
- b = bending allowance

- c = corrosion tolerance, c = 0.3 mm for hydraulic steel tube, c = 0 mm for SS tubes
- e = strength ratio: for seamless tubes e = 1
- D = tube outside diameter [mm]
- R_m = min. tensile strength [N/mm²]
- K = min. yield strength or min 0.2% proof stress [N/mm²]

Calculation of burst pressure:

$$BP = \frac{20 * R_m * t_n * a}{D - t_n * a}$$

- | | |
|---|---|
| stainless steel: | carbon steel: |
| σ _t = $\frac{R_m}{2.7}$ or $\frac{K}{1.6}$ | σ _t = $\frac{R_m}{2.7}$ or $\frac{K}{1.8}$ |

$$t_0 = t_n * a - c - b$$

$$b = \frac{1}{2.5} * \frac{D}{R} * t_0$$

$$b = 0.1333 * t_0 \text{ (at } R/D=3) \rightarrow t_0 = \frac{t_n * a - c}{1.1333}$$

Pressure reductions and temperatures

Required pressure reductions (depending on the material) with reference to the catalogue pressures for higher temperatures. Both metal fitting material and elastomeric sealing compound have to be selected according to the temperature range of the system.

DNV may require different pressure reduction based on application

Material	Pressure reduction of permissible operating temperatures TB in °C														
	-60	-54	-40	-35	-25	+20	+50	+100	+120	+150	+175	+200	+250	+300	+400
Steel components			10%			0%			11%	19%					
Steel, tubes			10%			0%			19%		27%				
Stainless steel components	0%					5%	15%	23%		29%		33%	37%	42%	
Stainless steel, tubes	0%					5.5%	11.5%	21.5%			29%		34%		
Sealing material NBR (e.g. Perbunan)															
Sealing material FKM															
Sealing material Polyurethan (P5008)															

	Permissible
	Ambient temperature of hydraulic and pneumatic applications
	Temperature not permissible

Calculation example:
 Temperature = 200°C
 Material = Stainless steel
 Pressure reduction = 29%
 Pressure reduction tubes = 21.5%
 PN tube 16x2.5/71. DIN2413 III = 362 bar

Formula:

$$PN_{200^{\circ}\text{C}} = \frac{400 \text{ bar}}{100\%} \times (100\% - 29\%) = 284 \text{ bar}$$

$$PN_{\text{tube } 200^{\circ}\text{C}} = \frac{362 \text{ bar}}{100\%} \times (100\% - 21.5\%) = 284 \text{ bar}$$

Flow diameter of tube lines

Determining tube sizes for hydraulic systems

Proper tube material, type and size for a given application and type of fitting are critical for efficient and trouble-free operation of the fluid system. Selection of proper tubing involves choosing the right tube material, and determining the optimum tube size (O.D. and wall thickness).

Proper sizing of the tube for various parts of a hydraulic system results in an optimum combination of efficient and cost effective performance.

A tube that is too small causes high fluid velocity, which has many detrimental effects. In pressure lines, it causes high friction losses and turbulence, both resulting in high pressure drops and heat generation. High heat accelerates wear in moving parts and rapid aging of seals and hoses, all resulting in reduced component life. High heat generation also means wasted energy, and hence, low efficiency. Too large tubes increase system cost. Thus, optimum tube sizing is very critical. The following is a simple procedure for sizing tubes.

Determine required flow diameter

Use table to determine recommended flow diameter for the required flow rate and type of line.

The table is based on the following recommended flow rates that are common in the shipbuilding and offshore engineering.

Pressure lines	- 3	→ 7.2	$\left[\frac{\text{m}}{\text{s}} \right]$
Return lines	- 2	→ 4.5	$\left[\frac{\text{m}}{\text{s}} \right]$
Suction lines	- 1	→ 1.8	$\left[\frac{\text{m}}{\text{s}} \right]$

Avoid flow rates > 8 m/s!

The resulting forces are high and can destroy the tube lines. If you desire to use different velocities than the above, use the following formula to determine the required flow diameter.

$$\text{Tube - I.D. [mm]} = 4,61 \times \sqrt{\frac{\text{Flow} \left[\frac{\text{ltr.}}{\text{min}} \right]}{\text{Velocity} \left[\frac{\text{m}}{\text{s}} \right]}}$$

Determine required wall thickness

Use tube/pressure calculation tables shown in the tube chapter to determine recommended wall thickness for the required working pressure and flow diameter of the line.

Therefore choose a working pressure which is equal or higher than the required working pressure.

Flow characteristics

Hydraulic systems are in most cases only rated with a flow velocity defined on the basis of experience. The pressure losses in lines are not taken into account, or measured later on when testing the system. As the pressure losses increase proportionally greater than the flow resistance, it is important to achieve the best rating of the system, so that they are already taken into account when planning the tube connections. Calculation is not as difficult as it is often thought, and this chapter is intended to provide a guideline. Besides, it provides information on how excessive pressure losses can be avoided, because pressure losses result in losses in performance and excessive heat. Noise occurs and possibly cavitation in suction lines.

Medium

All indication given with regard to flow restrictions and to flow properties refer exclusively to liquids. For gaseous media, the variable density of the gas must additionally be taken into account.

Units

c = Flow velocity $\left[\frac{\text{m}}{\text{s}} \right]$

d = Pipe inside diameter [m]

L = Pipe length [m]

ρ = Pressure [Pa], 1 bar = 100000 Pa

\dot{V} = Flow rate $\left[\frac{\text{m}^3}{\text{s}} \right]$, $1 \frac{\text{m}^3}{\text{s}} = 60000 \frac{\text{l}}{\text{min}}$

λ = Pipe friction factor

$\nu(T)$ = Kinematic viscosity of the medium depending on temperature $\left[\frac{\text{m}^2}{\text{s}} \right]$

$\rho(T)$ = Density of the medium depending on temperature $\left[\frac{\text{kg}}{\text{m}^3} \right]$

ζ = Individual pressure loss coefficient

Only base units have been used. This has the advantage that the formula do not contain correction factors and there is no danger of confusion, e.g. that values are used with the wrong unit. In case values are given in other units - the flow rate is e.g. often given in l/min - it is advisable to convert them into the base units before starting calculation.

Pressure losses in pipe lines

To calculate pressure losses in pipe lines, it must first be determined whether there is a laminar or a turbulent flow. Laminar flow is homogenous and without turbulence. In case of turbulent flow, the losses increase much more quickly.

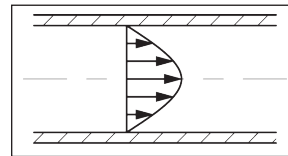

Flow profile with laminar flow

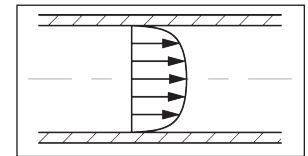

Flow profile with turbulent flow

The kind of flow is defined by the Reynolds' number. With a Reynolds' number of more than 2320, the flow changes to turbulent. The Reynolds' number is calculated according to the formula:

$$Re = \frac{c \cdot d}{\nu(T)}$$

The Reynolds' number is a non-dimensional number. The critical fluid velocity at which the flow regime can change, is thus calculated from:

$$c_{cr} = 2320 \cdot \frac{\nu(T)}{d} \left[\frac{\text{m}}{\text{s}} \right]$$

With a given flow rate, the fluid velocity can be calculated according to the formula:

$$c = \frac{\dot{V} \cdot 4}{d^2 \cdot \pi} \left[\frac{\text{m}}{\text{s}} \right]$$

Subsequently, the pipe friction factor λ can be calculated. The pipe friction factor λ is a function of the Reynolds' number and also depends on the roughness of the pipe. As hydraulically smooth pipes can generally be assumed in hydraulic applications, the pipe friction factor λ is calculated according to the following formula:

$$\text{laminar flow, } (Re < 2320): \lambda = \frac{64}{Re}$$

$$\text{turbulent flow, } (Re > 2320): \lambda = \frac{0.3164}{\sqrt[4]{Re}}$$

Finally, if all factors are known, the pressure loss in a certain pipe line can be calculated according to the formula:

$$\Delta p = \lambda \cdot \frac{L}{d} \cdot \frac{\rho(T) \cdot c^2}{2} \text{ [Pa]}$$

Calculation of individual losses

A hydraulic system does not only incorporate pipes, but also valves, fittings, pipe bends etc. that cause flow losses. These individual losses are often much higher than the pipe losses and are calculated according to the following formula:

$$\Delta p = \zeta \cdot \rho(T) \cdot \frac{c^2}{2} \text{ [Pa]}$$

Seamless EO steel tubes | Material E235+N / St.37.4 (1.0308)

Acc. to DIN EN 10305-4

1. DIN 2413 I: Tubes with a diameter of OD/ID>2 are calculated for static stress in accordance with DIN 2413 III but with K=yield strength.
2. Evaluated in Parker Lab and Test Field. () = Burst pressure (B.P.) acc. to Faupel-von-Mises

Material E235+N / St.37.4 (1.0308)		d _a Outer-Ø (mm)	Outer-Ø Tolerance (mm)	s Wall- thickness (mm)	d _i Inner-Ø (mm)	Design pressure		2 Burst pressure bar	Weight kg/m
Surface Phosphated and oiled	Cr(VI)- free					1 DIN 2413 I static PN bar	DIN 2413 III dynamic PN bar		
Order code									
R04X0.5	R04X0.5CF	04		0.50	3.0	313	273	1160	0.047
	R04X0.75CF	04	±0.08	0.75	2.5	470	391	1820	0.063
R04X1	R04X1CF	04		1.00	2.0	627	500	2700	0.074
	R05X1CF	05	±0.08	1.00	3.0	501	414	2120	0.099
	R06X0.75CF	06		0.75	4.5	333	288	1150	0.103
R06X1	R06X1CF	06		1.00	4.0	444	372	1650	0.123
R06X1.5	R06X1.5CF	06	±0.08	1.50	3.0	666	526	2550	0.166
	R06X2CF	06		2.00	2.0	692	662	>3500	0.197
R06X2.25	R06X2.25CF	06		2.25	1.5	757	725	>3500	0.208
R08X1	R08X1CF	08		1.00	6.0	333	288	1175	0.173
R08X1.5	R08X1.5CF	08	±0.08	1.50	5.0	499	412	1925	0.240
R08X2	R08X2CF	08		2.00	4.0	666	526	2500	0.296
	R08X2.5CF	08		2.50	3.0	658	630	2650	0.339
R10X1	R10X1CF	10		1.00	8.0	282	248	900	0.222
R10X1.5	R10X1.5CF	10		1.50	7.0	423	357	1450	0.314
R10X2	R10X2CF	10	±0.08	2.00	6.0	564	458	2025	0.395
R10X2.5	R10X2.5CF	10		2.50	5.0	705	551	2675	0.462
	R10X3CF	10		3.00	4.0	666	638	>3500	0.518
R12X1	R12X1CF	12		1.00	10.0	235	209	750	0.271
R12X1.5	R12X1.5CF	12		1.50	9.0	353	303	1150	0.388
R12X2	R12X2CF	12	±0.08	2.00	8.0	470	391	1600	0.493
	R12X2.5CF	12		2.50	7.0	588	474	2025	0.586
	R12X3CF	12		3.00	6.0	705	551	2600	0.666
	R12X3.5CF	12		3.50	5.0	651	624	(3109)	0.734
	R14X1.5CF	14		1.50	11.0	302	264	975	0.462
R14X2	R14X2CF	14	±0.08	2.00	10.0	403	342	1325	0.592
R14X2.5	R14X2.5CF	14		2.50	9.0	504	415	1650	0.709
	R14X3CF	14		3.00	8.0	604	485	2200	0.814
R15X1	R15X1CF	15		1.00	13.0	188	170	575	0.345
R15X1.5	R15X1.5CF	15	±0.08	1.50	12.0	282	248	950	0.499
R15X2	R15X2CF	15		2.00	11.0	376	321	1275	0.641
R16X1.5	R16X1.5CF	16		1.50	13.0	264	233	850	0.536
R16X2	R16X2CF	16	±0.08	2.00	12.0	353	303	1175	0.691
R16X2.5	R16X2.5CF	16		2.50	11.0	441	370	1500	0.832
R16X3	R16X3CF	16		3.00	10.0	529	433	1850	0.962
R18X1	R18X1CF	18		1.00	16.0	157	143	450	0.419
R18X1.5	R18X1.5CF	18		1.50	15.0	235	209	700	0.610
R18X2	R18X2CF	18	±0.08	2.00	14.0	313	273	975	0.789
R18X2.5	R18X2.5CF	18		2.50	13.0	392	333	1300	0.956
	R18X3CF	18		3.00	12.0	470	391	1575	1.111

Surface finish:

- Tubes with I.D. 1.5-5 mm: outside and inside oiled.
- Tubes from 6 mm I.D.: outside and inside phosphated and oiled.

• Cr(VI)-free:

These dimensions are externally thick coat passivated (thickness of coat 8-12µm), inside oiled.

Seamless EO steel tubes (continued) | Material E235+N / St.37.4 (1.0308)

Acc. to DIN EN 10305-4

1. DIN 2413 I: Tubes with a diameter of OD/ID>2 are calculated for static stress in accordance with DIN 2413 III but with K=yield strength.
2. Evaluated in Parker Lab and Test Field.

Material E235+N / St.37.4 (1.0308)		d _a Outer-Ø (mm)	Outer-Ø Tolerance (mm)	s Wall- thickness (mm)	d _i Inner-Ø (mm)	Design pressure		2 Burst pressure bar	Weight kg/m
Surface						1 DIN 2413 I static PN bar	DIN 2413 III dynamic PN bar		
Phosphated and oiled	Cr(VI)- free								
Order code									
R20X2 R20X2.5 R20X3	R20X1.5CF	20	±0.08	1.50	17.0	212	190	675	0.684
	R20X2CF	20		2.00	16.0	282	248	900	0.888
	R20X2.5CF	20		2.50	15.0	353	303	1100	1.079
	R20X3CF	20		3.00	14.0	423	357	1400	1.258
	R20X3.5CF	20		3.50	13.0	494	408	1650	1.424
	R20X4CF	20		4.00	12.0	564	458	2000	1.578
R22X1.5 R22X2 R22X2.5	R22X1.5CF	22	±0.08	1.50	19.0	192	173	550	0.758
	R22X2CF	22		2.00	18.0	256	227	775	0.986
	R22X2.5CF	22		2.50	17.0	320	278	1025	1.202
	R22X3CF	22		3.00	16.0	385	328	1175	1.406
R25X2 R25X2.5 R25X3 R25X4	R25X2CF	25	±0.08	2.00	21.0	226	201	725	1.134
	R25X2.5CF	25		2.50	20.0	282	248	850	1.387
	R25X3CF	25		3.00	19.0	338	292	1025	1.628
	R25X4CF	25		4.00	17.0	451	378	1500	2.072
	R25X4.5CF	25		4.50	16.0	508	418	1625	2.275
R28X1.5 R28X2 R28X2.5 R28X3	R28X1.5CF	28	±0.08	1.50	25.0	151	138	425	0.980
	R28X2CF	28		2.00	24.0	201	181	600	1.282
	R28X2.5CF	28		2.50	23.0	252	223	750	1.572
	R28X3CF	28		3.00	22.0	302	264	900	1.850
R30X2.5 R30X3 R30X4 R30X5	R30X2CF	30	±0.08	2.00	26.0	188	170	575	1.381
	R30X2.5CF	30		2.50	25.0	235	209	725	1.695
	R30X3CF	30		3.00	24.0	282	248	850	1.998
	R30X4CF	30		4.00	22.0	376	321	1175	2.565
	R30X5CF	30		5.00	20.0	470	391	1600	3.083
R35X2 R35X2.5 R35X3	R35X2CF	35	±0.15	2.00	31.0	161	147	450	1.628
	R35X2.5CF	35		2.50	30.0	201	181	600	2.004
	R35X3CF	35		3.00	29.0	242	215	700	2.367
	R35X4CF	35		4.00	27.0	322	280	960	3.058
R38X3 R38X4 R38X5	R38X2.5CF	38	±0.15	2.50	33.0	186	168	550	2.189
	R38X3CF	38		3.00	32.0	223	199	675	2.589
	R38X4CF	38		4.00	30.0	297	260	900	3.354
	R38X5CF	38		5.00	28.0	371	318	1150	4.069
	R38X6CF	38		6.00	26.0	445	373	1425	4.735
	R38X7CF	38		7.00	24.0	519	427	1700	5.352
R42X2 R42X3 R42X4	R42X2CF	42	±0.20	2.00	38.0	134	123	375	1.973
	R42X3CF	42		3.00	36.0	201	181	575	2.885
	R42X4CF	42		4.00	34.0	269	237	850	3.749

Other sizes on request!

Seamless EO steel tubes | Material E355+N / St. 52.4 (1.0580)

Acc. to DIN EN 10305-4

1. DIN 2413 I: Tubes with a diameter of OD/ID>2 are calculated for static stress in accordance with DIN 2413 III but with K=yield strength.
2. Burst pressure (B.P.) acc. to Faupel-von-Mises

Material E355+N / St.52.4 (1.0580)		d _a Outer-Ø (mm)	Outer-Ø Tolerance (mm)	s Wall- thickness (mm)	d _i Inner-Ø (mm)	Design pressure		2 Burst pressure bar	Weight kg/m
Surface Phosphated and oiled	Cr(VI)- free					1 DIN 2413 I static PN bar	DIN 2413 III dynamic PN bar		
Order code									
	R10X2ST52CF	10	±0.08	2.00	6.0	852	539	2671	0.395
	R12X1.5ST52CF	12	±0.08	1.50	9.0	533	357	1504	0.388
	R12X2ST52CF	12		2.00	8.0	710	461	2120	0.493
	R15X1.5ST52CF	15	±0.08	1.50	12.0	426	292	1167	0.499
	R15X2ST52CF	15		2.00	11.0	568	379	1622	0.641
R16X2ST52	R16X1.5ST52CF	16	±0.08	1.50	13.0	399	275	1086	0.536
	R16X2ST52CF	16		2.00	12.0	533	357	1504	0.691
	R16X2.5ST52CF	16		2.50	11.0	666	436	1959	0.832
	R18X1.5ST52CF	18	±0.08	1.50	15.0	355	247	953	0.610
	R18X2ST52CF	18		2.00	14.0	473	321	1314	0.789
	R20X2ST52CF	20	±0.08	2.00	16.0	426	292	1167	0.888
	R20X2.5ST52CF	20		2.50	15.0	533	357	1504	1.079
	R20X3ST52CF	20		3.00	14.0	639	420	185	1.258
	R22X1.5ST52CF	22	±0.08	1.50	19.0	290	204	767	0.758
	R22X2ST52CF	22		2.00	18.0	387	267	1049	0.986
R25X3ST52	R25X2.5ST52CF	25	±0.08	2.50	20.0	426	292	1167	1.387
	R25X3ST52CF	25		3.00	19.0	511	344	1435	1.628
	R25X4ST52CF	25		4.00	17.0	682	445	2016	2.072
	R28X2ST52CF	28	±0.08	2.00	24.0	304	213	806	1.282
R30X3ST52	R30X3ST52CF	30	±0.08	3.00	24.0	426	292	1167	1.998
	R30X4ST52CF	30		4.00	22.0	568	379	1622	2.565
	R30X5ST52CF	30		5.00	20.0	710	461	2120	3.083
	R35X3ST52CF	35	±0.15	3.00	29.0	365	253	983	2.367
R38X4ST52	R38X3ST52CF	38	±0.15	3.00	32.0	336	234	899	2.589
	R38X4ST52CF	38		4.00	30.0	448	306	1236	3.354
	R38X5ST52CF	38		5.00	28.0	561	374	1597	4.069
	R38X6ST52CF	38		6.00	26.0	673	440	1984	4.735
	R42X3ST52CF	42	±0.20	3.00	36.0	304	213	806	2.885
	R42X4ST52CF	42		4.00	34.0	406	279	1105	3.748
	R42X5ST52CF	42		5.00	32.0	507	342	1422	4.562

Surface finish:

- Tubes with I.D. 1.5-5 mm: outside and inside oiled.
- Tubes from 6 mm I.D.: outside and inside phosphated and oiled.

• Cr(VI)-free:

These dimensions are externally thick coat passivated (thickness of coat 8-12µm), inside oiled.

Other sizes on request!

Seamless EO stainless steel tubes | Material 316Ti (1.4571)

Acc. to DIN EN 10216-5, DIN EN 10305-1

1. DIN 2413 I: Tubes with a diameter of OD/ID>2 are calculated for static stress in accordance with DIN 2413 III but with K=yield strength.
2. Evaluated in Parker Lab and Test Field. () = Burst pressure (B.P.) acc. to Faupel-von-Mises

Material 316Ti (1.4571)	d _a Outer-Ø (mm)	Outer-Ø Tolerance (mm)	s Wall- thickness (mm)	d _i Inner-Ø (mm)	Design pressure		2 Burst pressure bar	Weight kg/m
					1	DIN 2413 III		
					DIN 2413 I static PN bar	dynamic PN bar		
R04X171	04	±0.08	1.0	2.0	735	539	(2961)	0.075
R06X171	06		1.0	4.0	490	383	1850	0.125
R06X1.571	06	±0.08	1.5	3.0	735	539	2900	0.169
R08X171	08		1.0	6.0	368	297	1300	0.175
R08X1.571	08	±0.08	1.5	5.0	551	424	2050	0.244
R10X171	10		1.0	8.0	294	242	950	0.225
R10X1.571	10	±0.08	1.5	7.0	441	349	1750	0.319
R10X271	10		2.0	6.0	588	447	2400	0.401
R12X171	12		1.0	10.0	245	205	850	0.275
R12X1.571	12	±0.08	1.5	9.0	368	297	1400	0.394
R12X271	12		2.0	8.0	490	383	1900	0.501
R14X1.571	14		1.5	11.0	315	258	1200	0.469
R14X271	14	±0.08	2.0	10.0	420	334	1550	0.601
R14X2.571	14		2.5	9.0	525	406	2100	0.720
R15X171	15		1.0	13.0	196	166	675	0.351
R15X1.571	15	±0.08	1.5	12.0	294	242	1100	0.507
R15X271	15		2.0	11.0	392	314	1400	0.651
R16X1.571	16		1.5	13.0	276	228	950	0.545
R16X271	16	±0.08	2.0	12.0	368	297	1300	0.701
R16X2.571	16		2.5	11.0	459	362	1850	0.845
R16X371	16		3.0	10.0	551	424	2400	0.977
R18X1.571	18		1.5	15.0	245	205	800	0.620
R18X271	18	±0.08	2.0	14.0	327	267	1150	0.801
R20X271	20		2.0	16.0	294	242	1050	0.901
R20X2.571	20	±0.08	2.5	15.0	368	297	1400	1.095
R20X371	20		3.0	14.0	441	349	1800	1.277
R22X1.571	22		1.5	19.0	200	170	650	0.770
R22X271	22	±0.08	2.0	18.0	267	222	900	1.002
R25X271	25		2.0	21.0	235	197	763	1.152
R25X2.571	25	±0.08	2.5	20.0	294	242	1050	1.408
R25X371	25		3.0	19.0	353	286	1275	1.653
R28X1.571	28		1.5	25.0	158	135	550	0.995
R28X271	28	±0.08	2.0	24.0	210	177	700	1.302
R28X2.571	28		2.5	23.0	263	218	(840)	1.596
R30X2.571	30		2.5	25.0	245	205	850	1.722
R30X371	30	±0.08	3.0	24.0	294	242	1150	2.028
R30X471	30		4.0	22.0	392	314	1500	2.605
R35X271	35		2.0	31.0	168	143	550	1.653
R35X2.571	35	±0.15	2.5	30.0	210	177	(659)	2.035
R35X371	35		3.0	29.0	252	210	(803)	2.404
R38X2.571	38		2.5	33.0	193	164	628	2.222
R38X471	38	±0.15	4.0	30.0	309	254	1150	3.405
R42X271	42		2.0	38.0	140	121	475	2.003
R42X371	42	±0.20	3.0	36.0	210	177	750	2.930

Other sizes on request!

Seamless EO stainless steel tubes | Material 316L (1.4404)

Acc. to ASTM A269/A213

1. DIN 2413 I static pressure (W.P.) capability for straight pipe including manufacturing tolerance.
2. Burst pressure (B.P.) acc. to Faupel-von-Mises

Material 316L (1.4404)		d _a Outer-Ø (mm)	Outer-Ø Tolerance (mm)	s Wall- thickness (mm)	d _i Inner-Ø (mm)	1 Design pressure		2 Burst pressure bar	Weight kg/m
Surface pickled	bright annealed					DIN 2413 I static PN bar	DIN 2413 III dynamic PN bar		
Order code									
	R04X1-316BA	04	±0.08	1.0	2.0	735	539	2961	0.075
	R06X1-316BA	06	±0.08	1.0	4.0	490	383	1732	0.125
	R06X1.5-316BA	06		1.5	3.0	735	539	2961	0.169
	R08X1-316BA	08	±0.08	1.0	6.0	368	297	1229	0.175
	R10X1-316BA	10	±0.08	1.0	8.0	294	242	953	0.225
	R10X1.5-316BA	10		1.5	7.0	441	349	1524	0.319
	R10X2-316BA	10		2.0	6.0	588	447	2182	0.401
	R12X1-316BA	12	±0.08	1.0	10.0	245	205	779	0.275
	R12X1.5-316BA	12		1.5	9.0	368	297	1229	0.394
	R12X2-316BA	12		2.0	8.0	490	383	1732	0.501
	R15X1.5-316BA	15	±0.08	1.5	12.0	294	242	953	0.507
R16X2-316		16	±0.08	2.0	12.0	368	297	1229	0.701
R16X2.5-316		16		2.5	11.0	459	362	1601	0.845
R18X1.5-316		18	±0.08	1.5	15.0	245	205	779	0.620
R18X2-316		18		2.0	14.0	327	267	1074	0.801
R20X2-316		20	±0.08	2.0	16.0	294	242	953	0.901
R20X2.5-316		20		2.5	15.0	368	297	1229	1.096
R22X2-316		22	±0.08	2.0	18.0	267	222	857	1.002
R25X2-316		25	±0.08	2.0	21.0	235	197	745	1.152
R25X2.5-316		25		2.5	20.0	294	242	953	1.409
R25X3-316		25		3.0	19.0	353	286	1172	1.653
R28X2-316		28	±0.08	2.0	24.0	210	177	659	1.302
R30X2.5-316		30	±0.08	2.5	25.0	245	205	779	1.722
R30X3-316		30		3.0	24.0	294	242	953	2.028
R35X3-316		35	±0.15	3.0	29.0	252	210	803	2.404
R38X3-316		38	±0.15	3.0	32.0	232	195	734	2.629
R38X4-316		38		4.0	30.0	309	254	1010	3.405
R38X5-316		38		5.0	28.0	387	311	1305	4.132
R38X6-316		38		6.0	26.0	464	365	1621	4.808
R42X3-316		42	±0.20	3.0	36.0	210	177	659	2.930

Other sizes on request!

Seamless EO stainless steel tubes | Material 316L (1.4404)

Acc. to DIN EN 10216-5, DIN EN 10305-1

1. DIN 2413 I: Tubes with a diameter of OD/ID>2 are calculated for static stress in accordance with DIN 2413 III but with K=yield strength.
2. Burst pressure (B.P.) calculation acc. to Faupel-von-Mises

Material 316 L (1.4404)	d _a Outer-Ø (mm)		s Wallthickness		d Inner-Ø (mm)	1 Design pressure		2 Burst pressure bar	Weight kg/m
						DIN 2413 I static PN bar	DIN 2413 III dynamic PN bar		
	Inch	mm	Inch	mm		Surface bright annealed	Order code		
R1/8X0.028TP316/L	1/8	3.18	0.028	0.71	1.76	659	492	2538	0.044
R3/16X0.035TP316/L	3/16	4.76	0.035	0.89	2.98	549	422	1996	0.086
R1/4X0.035TP316/L	1/4	6.35	0.035	0.89	4.57	412	328	1403	0.122
R1/4X0.049TP316/L			0.049	1.24	3.87	576	440	2126	0.159
R1/4X0.065TP316/L			0.065	1.65	3.05	619	556	3135	0.194
R3/8X0.035TP316/L	3/8	9.53	0.035	0.89	7.75	274	227	883	0.193
R3/8X0.049TP316/L			0.049	1.24	7.05	384	309	1294	0.257
R3/8X0.065TP316/L			0.065	1.65	6.23	510	396	1818	0.326
R1/2X0.035TP316/L	1/2	12.70	0.035	0.89	10.92	206	174	644	0.263
R1/2X0.049TP316/L			0.049	1.24	10.22	288	238	932	0.356
R1/2X0.065TP316/L			0.065	1.65	9.40	382	307	1286	0.457
R1/2X0.083TP316/L			0.083	2.11	8.48	488	381	1724	0.560
R5/8X0.049TP316/L	5/8	15.88	0.049	1.24	13.40	230	193	729	0.455
R5/8X0.065TP316/L			0.065	1.65	12.58	306	251	996	0.588
R3/4X0.049TP316/L	3/4	19.05	0.049	1.24	16.57	192	163	598	0.553
R3/4X0.065TP316/L			0.065	1.65	15.75	255	212	813	0.719
R3/4X0.083TP316/L			0.083	2.11	14.83	325	266	1069	0.895
R3/4X0.095TP316/L			0.095	2.41	14.23	372	300	1248	1.004
R3/4X0.109TP316/L			0.109	2.77	13.51	427	339	1467	1.129
R1X0.065TP316/L	1	25.40	0.065	1.65	22.10	191	162	595	0.981
R1X0.083TP316/L			0.083	2.11	21.18	244	204	775	1.231
R1X0.095TP316/L			0.095	2.41	20.58	279	231	900	1.387
R1X0.126TP316/L			0.126	3.20	19.00	370	299	1240	1.779

Other sizes on request!

Seamless EO tube bends 90° Material E235N (St. 37.4) and 1.4571

For minimum pressure loss

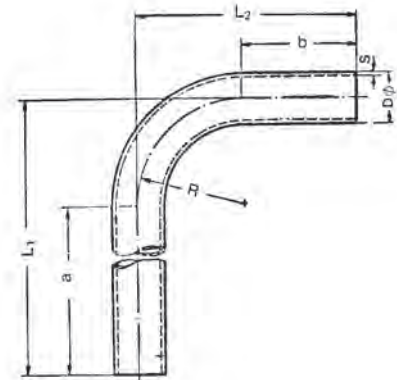

Order code		Tube O.D. D	Tolerance ±	Wall- thickness S	Tube I.D. mm	Bending radius R	Leg length		Length		Weight kg/piece
Cr(VI)-free	1.4571						a	b	L1	L2	
RB16X2CF	RB16X271	16	0.08	2.0	12	30	200	40	230	70	0.198
RB18X1.5CF	RB18X1.571	18	0.08	1.5	15	36	200	35	236	71	0.178
RB20X2CF	RB20X2.571	20	0.08	2.0	16	36	200	45	236	81	0.268
RB20X2.5CF		20	0.08	2.5	15	36	200	45	236	81	0.326
RB22X1.5CF	RB22X271	22	0.08	1.5	19	38	200	40	238	78	0.227
RB22X2CF		22	0.08	2.0	18	38	200	40	238	78	0.296
RB25X2CF	RB25X2.571	25	0.08	2.0	21	44	200	50	244	94	0.362
RB25X2.5CF		25	0.08	2.5	20	44	200	50	244	94	0.442
RB25X3CF		25	0.08	3.0	19	44	200	50	244	94	0.519
RB28X1.5CF	RB28X271	28	0.08	1.5	25	48	200	50	248	98	0.319
RB28X2CF		28	0.08	2.0	24	48	200	50	248	98	0.417
RB28X3CF		28	0.08	3.0	22	48	200	50	248	98	0.601
RB30X2.5CF	RB30X371	30	0.08	2.5	25	50	200	60	250	110	0.575
RB30X3CF		30	0.08	3.0	24	50	200	60	250	110	0.677
RB30X4CF		30	0.08	4.0	22	50	200	60	250	110	0.869
RB35X2CF	RB35X271	35	0.15	2.0	31	60	200	65	260	125	0.586
RB35X3CF		35	0.15	3.0	29	60	200	65	260	125	0.852
RB38X2.5CF	RB38X471	38	0.15	2.5	33	65	200	75	265	140	0.827
RB38X3CF		38	0.15	3.0	32	65	200	75	265	140	0.979
RB38X4CF		38	0.15	4.0	30	65	200	75	265	140	1.268
RB38X5CF		38	0.15	5.0	28	65	200	75	265	140	1.538
RB42X2CF	RB42X271	42	0.20	2.0	38	80	200	85	280	165	0.809
RB42X3CF		42	0.20	3.0	36	80	200	85	280	165	1.183
RB50X6*		50	0.20	6.0	38	180	150	150	330	330	3.496
RB65X8*		65	0.30	8.0	49	180	160	160	330	330	6.294

Tolerances for leg length a, b = ±2.5 mm

For tube bends, contrary to straight tubes of the same wall thickness there is a higher stress at the inside of the bend and a reduction of the fatigue strength, because of the out-of-round of tube. Details see DIN 2413 III section 4.7.

If the elbow end is cut off to a different length, a recalibration of the tube end may be necessary.

Tube bends material E235N (St. 37.4) are phosphated and oiled. (Yellow chromated on request.)

*phosphated and oiled



EO[®] Ermeto Original *Tube clamps*

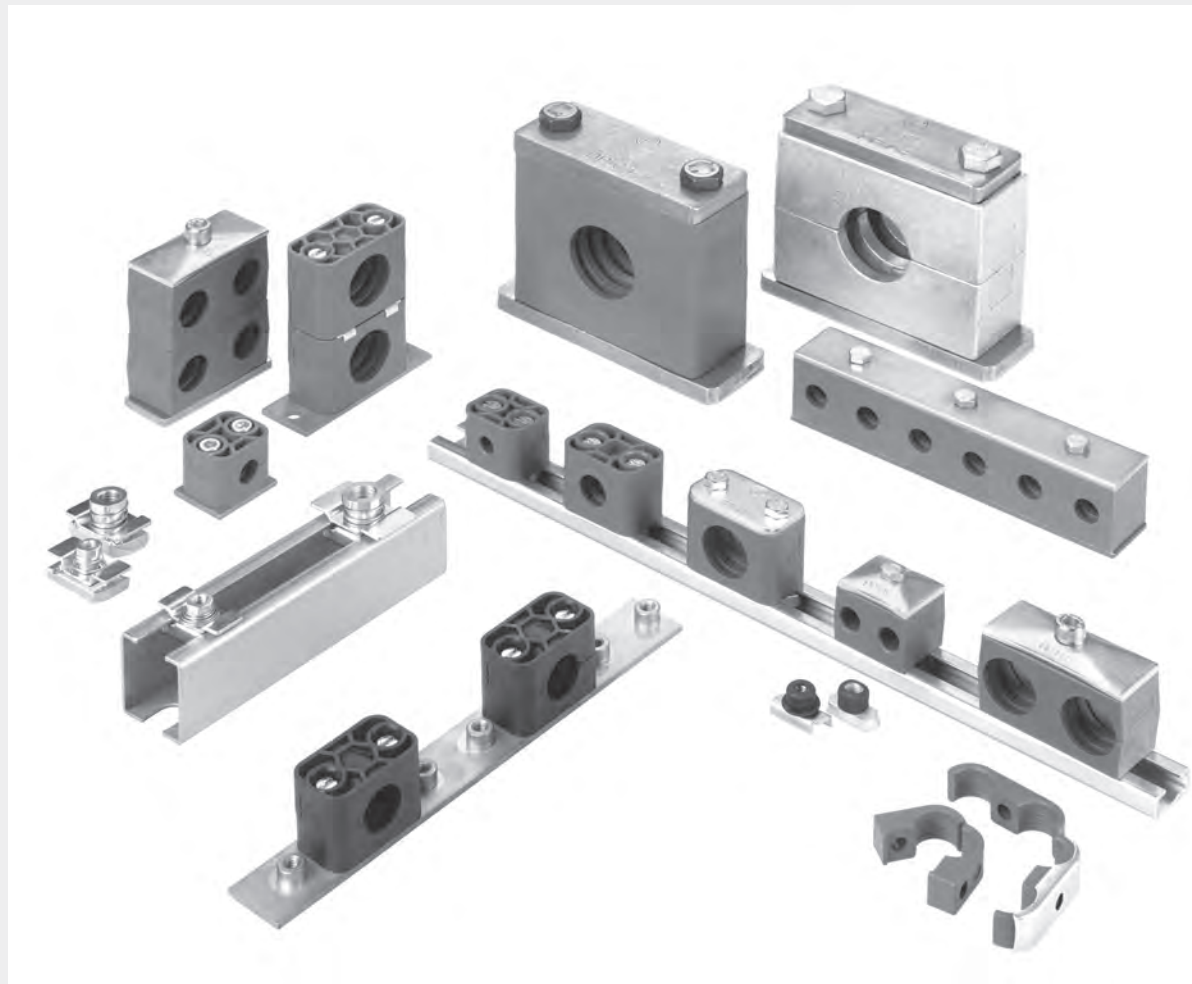

Content

Technical data T3
 Material properties T4
 Special materials T5
 Assembly instruction T6

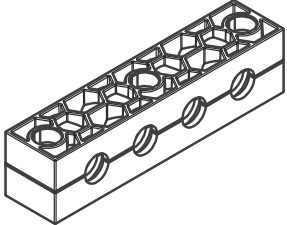
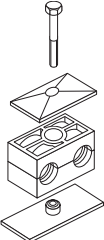
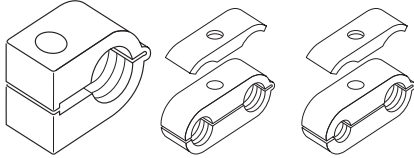
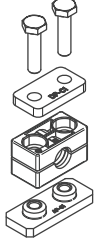
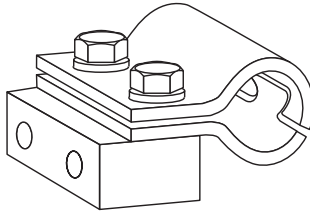
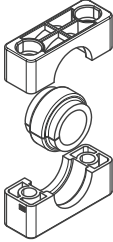
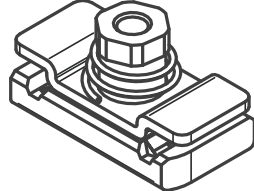
<p>Series A Light series (DIN 3015-1)</p>	 <p>T8-T23</p>	<p>Multiclamps</p>	 <p>T38-T43</p>
<p>Series B Double series (DIN 3015-3)</p>	 <p>T24-T28</p>	<p>Series O</p>	<p>single double</p>  <p>T44-T45</p>
<p>Series C Heavy series (DIN 3015-2)</p>	 <p>T29-T37</p>	<p>Hydraulic steel clamps</p>	 <p>T46-T47</p>
		<p>Tube clamps with Elastomer inlay</p>	 <p>T48-T50</p>
		<p>Fixed adaptor</p>	 <p>T51-T54</p>

Tube clamps

DIN 3015

Programme:

Tube clamps series A (according to DIN 3015 Part 1)

Available in nine standard sizes for normal mechanical requirements.

- Outer tube diameter for the metric series 4 to 101.8 mm
- Outer tube diameter for the inch-size series R 1/8" to R 3 1/2"
- Outer tube diameter for the imperial size series 1/4" to 4"

Accessories and construction types

Tube clamps series B (according to DIN 3015 Part 3)

Available as a twin tube clamp in five standard sizes for normal mechanical requirements.

- Outer tube diameter for the metric series 6 to 42 mm
- Outer tube diameter for the inch-size series R 1/8" to R 1 1/4"
- Outer tube diameter for the imperial size series 1/4" to 1 1/2"

Double tube clamps with different tube o.d. are available on request.

Accessories and construction types

Tube clamps series C (according to DIN 3015 Part 2)

Specially designed for high mechanical requirements, and available in ten standard sizes.

- Outer tube diameter for the metric series 6 to 406.4 mm
- Outer tube diameter for the inch-size series R 1/8" to R 16"
- Outer tube diameter for the imperial size series 5/16" to 12 3/4"

Accessories and construction types

Design:

According to DIN 3015:
Both upper and lower clamp-halves are identical.
Webs inside the bore of the clamps provide an impact and vibration deadening effect, and absorb the forces towards the direction of the tube axis.
For mounting hoses and cables it is recommended that clamps with a smooth interior surface and without prestress (block height C is reduced by gap height S) are used.

Clamp material:

Polypropylene	-30°C up to + 90° C	colour dark green
Polyamide	-40°C up to + 120° C	colour black
Rubber	-50°C up to + 120° C	colour black
Aluminium	-40°C up to + 300° C	

Stainless steel upon request.

Non standard colours upon request.

Special materials

Flame retardant.....p. T5
Corrosion retardant..... p. T5

Resistance to stress:

The remarkable features of **Tube Clamps** are their considerable re-set capability, high tensile strength, as well as their very high output strength and excellent resistance to cold. The choice of design and clamp material depends on the specific demands of the mechanical and thermal requirements.

Order code:

The order code for clamp halves as well as the reference No. for complete tube clamps incorporates the serial indication, material description and interior surface.

In accordance with DIN 3015, clamps always consist of two clamp halves. (1 clamp = 2 clamp halves)

Example of description:

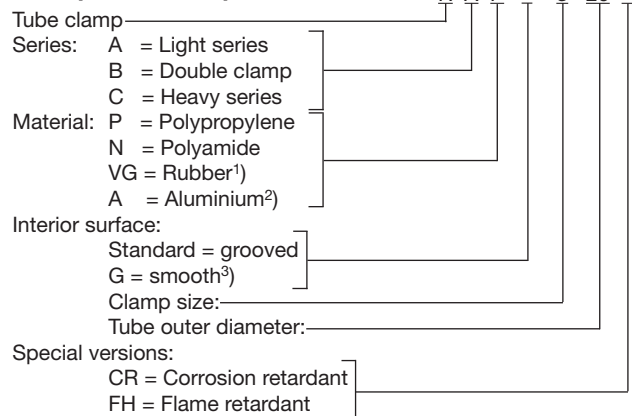

¹⁾ Rubber only available for series A and B, inside smooth and series C grooved design (G).
²⁾ Aluminium only available for series A size 0 to 6 and series C size 1 to 8. Aluminium clamps only available in a grooved design.
³⁾ Inside smooth series A not for size 0.
Inside smooth series C only up to size 8.
Clamps with smooth interior surface and without prestress

Finish of the metal components:

All metal components are available in steel and stainless steel.

Stainless steel quality:

Stainless steel W5 (1.4401 or 1.4571) from stock, W4 (1.4301 or 1.4305) available on request.

Surfaces steel:

As is standard, the steel components have the following surfaces:

Metal part	Series A+B		Series C	
	Bolt	Cr(VI)-free zinc plated		phosphated
Cover plate	Cr(VI)-free zinc plated		phosphated	Cr(VI)-free zinc plated
Welding plate	phosphated		phosphated	
Mounting rail nut	Cr(VI)-free zinc plated		Cr(VI)-free zinc plated	
Mounting rail	plain & oiled	Cr(VI)-free zinc plated	plain & oiled	Cr(VI)-free zinc plated

Surfaces differing from this are available on request.

Registration:

On request.

Tube clamps material properties

DIN 3015

Mechanical properties	Polypropylene (PP)	Polyamide (PA)	Aluminium (Al)	Rubber (TPE)
Density	0.90 g/cm ³	1.10 g/cm ³	2.65 g/cm ³	0.97 g/cm ³
Impact value at 23 °C	7 kJ/m ² (ISO 179/1eA)	8 kJ/mm ² (ISO 179/1eA)	–	–
Impact value at -20 °C	3 kJ/m ² (ISO 179/1eA)	–	–	–
Modulus of elasticity	1.400 N/mm ² (ISO 527)	2.000 N/mm ² (ISO 527)	72.000 N/mm ²	–
Yield stress. resp. tensile strength (Rm)	28 N/mm ² (ISO 527)	50 N/mm ² (ISO 527)	>240 N/mm ²	5.2 ... 8.8 N/mm ² (ASTM D412)

Thermal properties				
Temp. resistance	-30 ... +90°C	-40 ... +120°C	-40 ... +300°C	-50 ... +120°C

Chemical properties				
Weak acids	limited resistant	limited resistant	limited resistant	resistant
Weak alkalis	limited resistant	limited resistant	limited resistant	resistant
Alcohol	resistant	resistant	resistant	resistant
Petrol	limited resistant	resistant	resistant	limited resistant
Mineral oils	limited resistant	resistant	resistant	resistant
Other oils	resistant	resistant	resistant	resistant
Sea Water	resistant	resistant	limited resistant	resistant

The outlined particulars are approximate values and are only shown for reference, which are not binding, and with regard to possible protection of third parties. They do not exempt you from your own examination of suitability of the products delivered by us. Therefore, these values can only be used in a limited way for guidance only.

The application of the products is carried out outside of our control and, therefore, is exclusively subject to your own area of responsibility. Any claim however would be limited for all damages to the value of the goods supplied by us and in use by you.

It goes without saying, that we guarantee the perfect quality of our products according to our general sales and delivery conditions.

Special materials

Flame retardant clamps for railway vehicles EN 45545-2

Our flame retardant finish is the ideal solution for the transport and railway market. This provides increased safety and efficiency for railway vehicles.

Material:	Polypropylene (PP-F)	Polyamide (PA-F)	Rubber (TPE-F)
T01 EN ISO 4589-2: Oxygen Index	OI = 38.7 %	OI = 35.5 %	OI = 33.4 %
T10.03 EN ISO 5659-2: 25 kW/m ²	D _S max. = 48	D _S max. = 124	D _S max. = 79
T12 NF X 70 100-1 & -2: 600°C	CIT _{NLP} = 0.15	CIT _{NLP} = 0.51	CIT _{NLP} = 0.15
Compliance of the requirement set R22, 23, 24, 26 for the hazard level:	HL1 - HL2 - HL3	HL1 - HL2 - HL3	HL1 - HL2 - HL3

The advantages:

- Improved railway vehicle safety
- Flame retardant in accordance with DIN 45545-2, UL 94, DIN 3015, BS 6853, DIN 5510-2, NF F 16-101 NF F 16-101, BS 6853, UL 94
- 2+5 system. Only 2 sizes for tube diameters 6-42 mm
- Plates and rails in steel and stainless steel

Standard compliance:

Flame protected tube clamps DIN 3015 certification in line with:

- BS 6853
- DIN 5510-2
- DIN EN 45545
- UL 94
- NF F 16-101

For the original material polypropylene, the color of the clamp is white, black for polyimid and solid rubber.

Example of description:

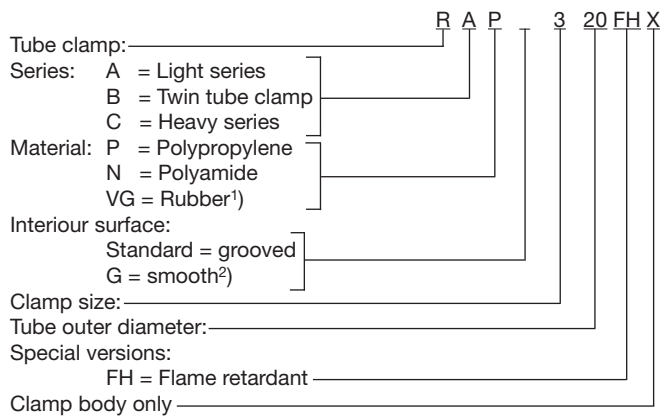

Corrosion retardant clamps

Our anti-corrosion finish is the ideal solution for areas at risk of corrosion.

Anticorrosion was developed on the basis of the approved polypropylene.

A specialised corrosion inhibitor effectively slows down the development of crevice corrosion between the clamp bodies and the tubework.

These corrosion-preventing properties were tested and recorded by salt spray tests in accordance with DIN EN ISO 9227.

Tube clamps made of PP-CR are available in the A+C series of our approved tube clamp range.

The source material is polypropylene, and the colour of the clamps is always slate grey.

Advantages:

- Enormous reduction of crevice corrosion
- Extension of maintenance intervals
- Cost reduction due to extended durability of the tubing

Example of description:

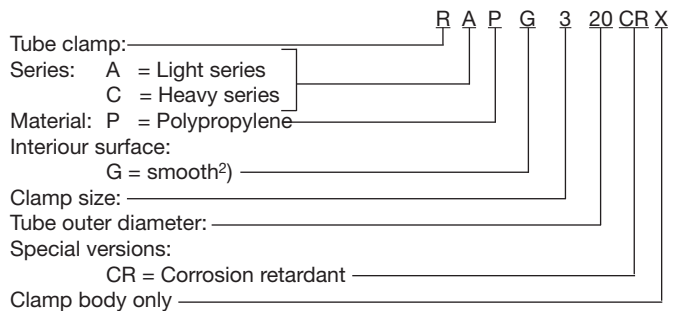

¹⁾ Rubber for series A and B only with smooth interior surface (G).

²⁾ Inside smooth series A not for size 0.

Inside smooth series C only up to size 8.

Clamps with smooth interior surface and without prestress.

Tube clamps assembly instruction

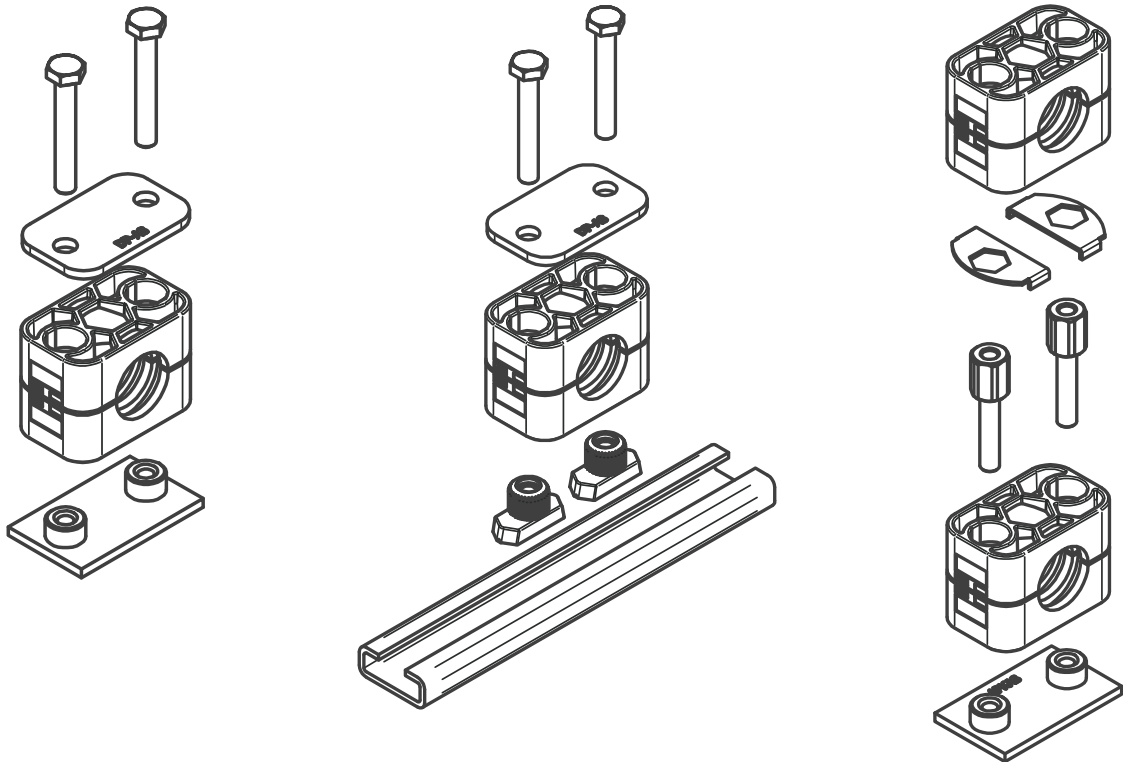

Assembly:

Assembly on to metal welding plates

Place welding plates on a base appropriate for the load. Make sure that the clamps are properly aligned. Clamp lower clamp half onto welding plate, insert tube, place upper clamp half onto lower half and fasten with the screws. Attention must be paid to the bias (after completed assembly, clamp halves may not be in contact)! Do not weld with fitted plastic clamp! Extended welding plates may be screw-fastened to the base.

Assembly on support rails

Support rails are available in four different heights and come in pieces of 1 m or 2 m length, as required. Weld on support rail or screw-fasten with fastening angle bracket. Insert support rail nuts in rail and turn until stoppage. For heavy duty construction series, nuts are simply pushed in. Clamp lower clamp half on support rail nuts, insert tube, place upper clamp half onto lower half and fasten with the screws. Before fastening the screws the clamp may still be positioned. Attention must be paid to the bias (after completed assembly, the clamp halves may not be in contact)!

Construction assembly

Clamps allow the assembly of multiple clamps of the same construction size and of different tube diameters one above the other. The construction assembly is carried out with special fixing screws that are secured against twisting by applying a locking plate. Clamp lower clamp half on welding plate or support rail respectively, insert tube, place upper clamp half on lower half and fasten with fixing screws. The fixing screw juts out from the upper clamp half. The application of a locking plate securely fastens the fixing screw and prevents twisting. Clamp on second clamp half on to the fixing screws etc.

Tube clamps

DIN 3015

Screw tightening torque and axial pipe shearing forces

The indicated screw tightening torque and axial pipe shearing forces refer to the assembly with cover plates and outside hexagon bolts according to DIN 931/933.

The axial pipe shearing force (according to DIN 3015, part 10) is an average value, determined by three tests made with a steel pipe according to DIN 2448 of St. 37, for which static friction is assumed (temperature during tests: 23°C). When loading the clamp with the indicated test force (F) in axial pipe direction, the pipe must not slide in the clamp.

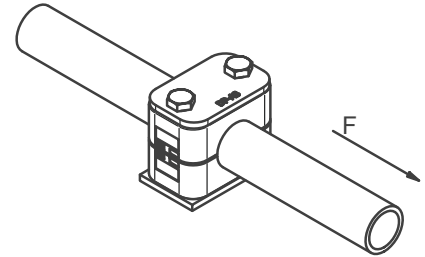

Series A - Light series (DIN 3015, part 1)

Size	Fixing screw DIN 931/933	Polypropylene		Polyamide		Aluminium	
		Screw tightening torque (Nm)	Pipe shearing force F (kN)	Screw tightening torque (Nm)	Pipe shearing force F (kN)	Screw tightening torque (Nm)	Pipe shearing force F (kN)
0	M6	8	0.6	10	0.6	–	–
1	M6	8	1.1	10	0.7	12	4.2
2	M6	8	1.2	10	0.8	12	4.3
3	M6	8	1.4	10	1.6	12	4.8
4	M6	8	1.5	10	1.7	12	5.0
5	M6	8	1.9	10	2.0	12	7.3
6	M6	8	2.0	10	2.5	12	8.9
7	M6	8	2.3	10	3.2	–	–
8	M6	8	2.6	10	3.5	–	–

Series B - Double series (DIN 3015, part 3)

Size	Fixing screw DIN 931/933	Polypropylene		Polyamide	
		Screw tightening torque (Nm,)	Pipe shearing force F (kN)	Screw tightening torque (Nm)	Pipe shearing force F (kN)
1	M6	5	0.9	6	0.9
2	M8	12	2.1	12	2.2
3	M8	12	1.9	12	2.0
4	M8	12	2.7	12	2.9
5	M8	8	1.7	8	2.5

Series C - Heavy series (DIN 3015, part 2)

Size	Fixing screw DIN 931/933	Polypropylene		Polyamide		Aluminium	
		Screw tightening torque (Nm)	Pipe shearing force F (kN)	Screw tightening torque (Nm)	Pipe shearing force F (kN)	Screw tightening torque (Nm)	Pipe shearing force F (kN)
1	M10	12	1.6	20	4.2	30	12.1
2	M10	12	2.9	20	4.5	30	15.1
3	M10	15	3.3	25	5.1	35	15.5
4	M12	30	8.2	40	9.3	55	29.4
5	M16	45	11.0	55	15.8	120	34.8
6	M20	80	14.0	150	21.0	220	50.0
7	M24	110	28.0	200	32.0	250	70.6
8	M30	180	40.0	350	48.0	500	84.5
9	M30	200	119.0	370	125.0	500	181.5
10	M30	270	168.0	450	180.0	600	244.5

For further information on clamp mouting, see page F14 following.

Tube clamps

Tube clamps series A (Light construction series) – Components

DIN 3015, part 1

Order codes for clamp halves:

Material	Interior surface	Order code
Polypropylene	grooved	RAP
	smooth	RAPG
Polyamide	grooved	RAN
	smooth	RANG
Rubber	smooth	RAVG¹⁾
Aluminium	grooved	RAA²⁾

(Please exchange as required standard abbreviation RAP in column for "clamp halves")

For flame- or corrosion retardant materials, please refer to page T5.

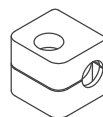

size 0

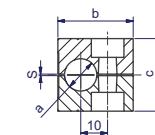

size 0

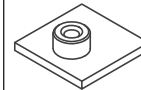

size 0

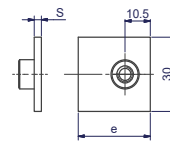

size 0

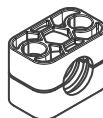

size 1-8

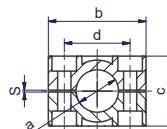

size 1-8

Width: 30 mm

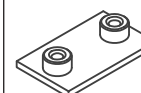

size 1-8

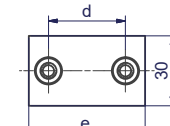

size 1-8

clamp size	Tube O.D. mm a	Tube NB	Tube O.D.	1 part 2 clamp halves		welding plate, short			
				RAP... Order code	dimensions: b c d s	APK A... Order code	dimensions: d e s		
0	4.0	G 1/8	1/4 5/16 3/8	RAP004X RAP006X RAP006.4X RAP008X RAP009.5X RAP010X RAP012X	28 27 - 0.6	APKA0...*	-	30	3
	6.0								
	6.4								
	8.0								
	9.5								
	10.0								
12.0									
1	4.0	G 1/8	1/4 5/16 3/8	RAP104X RAP106X RAP106.4X RAP108X RAP109.5X RAP110X RAP112X	34 27 20 0.6	APKA1...*	20	36	3
	6.0								
	6.4								
	8.0								
	9.5								
	10.0								
12.0									
2	12.7	G 1/4	1/2	RAP212.7X RAP213.5X RAP214X RAP215X RAP216X RAP217.2X RAP218X	42 33 26 0.8	APKA2...*	26	42	3
	13.5								
	14.0								
	15.0	G 3/8	5/8	RAP319X RAP320X RAP321.3X RAP322X RAP323X RAP325X RAP325.4X	49 35 33 1.0	APKA3...*	33	50	3
	16.0								
	17.2								
18.0									
4	26.9	G 3/4		RAP426.9X RAP428X RAP430X	59 42 40 1.2	APKA4...*	40	59	3
	28.0								
	30.0								
5	32.0	G 1	1 1/4	RAP532X RAP533.7X RAP535X RAP538X RAP540X RAP542X	71 58 52 1.2	APKA5...*	52	72	3
	33.7								
	35.0								
	38.0	G 1 1/4	1 1/2						
	40.0								
	42.0								

Continuation see next page ...

Tube clamps series A (Light construction series) – Components (Continued)

DIN 3015, part 1

Order codes for clamp halves:

Material	Interior surface	Order code
Polypropylene	grooved	RAP
	smooth	RAPG
Polyamide	grooved	RAN
	smooth	RANG
Rubber	smooth	RAVG¹⁾
Aluminium	grooved	RAA²⁾

(Please exchange as required standard abbreviation RAP in column for “clamp halves”)

For flame- or corrosion retardant materials, please refer to page T5.

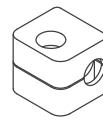

size 0

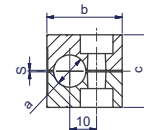

size 0

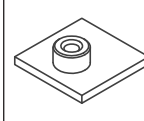

size 0

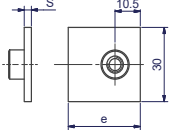

size 0

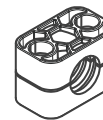

size 1-8

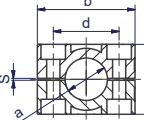

size 1-8

Width: 30 mm

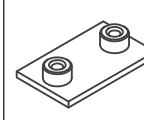

size 1-8

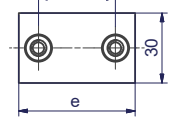

size 1-8

clamp size	Tube O.D. mm a	Tube NB	Tube O.D.	1 part 2 clamp halves		welding plate, short			
				RAP... Order code	dimensions: b c d s	APK A... Order code	dimensions: d e s		
6	44.5	G 1 1/2	1 3/4	RAP644.5X RAP645X RAP648X RAP650X RAP650.8X RAP652X RAP654X RAP655X RAP657X	86 66 66 1.2	APKA6...*	66	88	3
	45.0								
	48.0								
	50.0								
	50.8								
	52.0								
	54.0								
55.0	2								
57.0									
7	57.2	G 2	2 1/4	RAP757.2X RAP760.3X RAP763.5X RAP770X RAP773X RAP776.1X	121 93.6 94 1.6	APKA7...*	94	122	5
	60.3								
	63.5								
	70.0								
	73.0								
	76.1								
8	88.9	G 2 1/2	3	RAP888.9X RAP8101.8X	147 117.6 120 1.6	APKA8...*	120	148	5
	101.8								

¹⁾ When assembling solid rubber clamps, covering plates, hexagon screws and locking washers must be used.

²⁾ Aluminium sizes 0-6

*Please add the suffix below according to the surface/material required.

Order code suffixes		
Surface/material	Suffix	Example
Steel, phosphated	X	APKA0X
Steel, zinc plated, Cr(VI)-free	VZX	APKA0VZX
Stainless Steel 1.4571	4571X	APKA04571X

Tube clamps

Tube clamps series A (Light construction series) – Components

DIN 3015, part 1

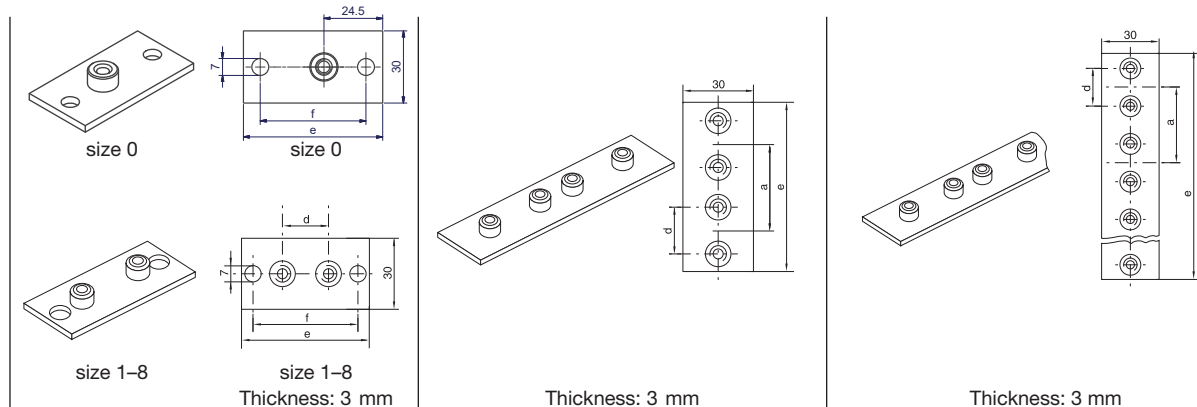

clamp size	weld/screw plate, long			twin welding plate			multiple weld plate					
	APL A... Order code	dimensions: d e f			APD A... Order code	dimensions: d a e			APR A... Order code	dimensions: d a e		
0	APLA0...*	–	58	44	APDA0...*	–	30	61	APRA0...* (10 clamps)	–	30	298
1	APLA1...*	20	64	50	APDA1...*	20	35	69	APRA1...* (10 clamps)	20	35	349
2	APLA2...*	26	70	56	APDA2...*	26	43	86	APRA2...* (10 clamps)	26	43	427
3	APLA3...*	33	78	64	APDA3...*	33	52	104	APRA3...* (10 clamps)	33	52	516
4	APLA4...*	40	87	73	APDA4...*	40	60	117	APRA4...* (5 clamps)	40	60	297
5	APLA5...*	52	100	86	APDA5...*	52	75	145	APRA5...* (5 clamps)	52	75	370
6	APLA6...*	66	116	100	APDA6...*	66	90	176	APRA6...* (5 clamps)	66	90	446
7	APLA7...*	94	150	136								
8	APLA8...*	120	178	162								

*Please add the suffix below according to the surface/material required.

Order code suffixes		
Surface/material	Suffix	Example
Steel, phosphated	X	APLA0X
Steel, zinc plated, Cr(VI)-free	VZX	APLA0VZX
Stainless Steel 1.4571	4571X	APLA04571X

Tube clamps series A (Light construction series) – Components

DIN 3015, part 1



size 0

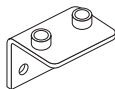

size 1-6

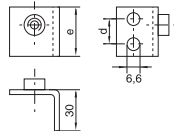

size 0

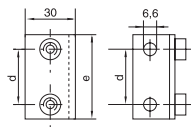

size 1-6

Thickness: 3 mm

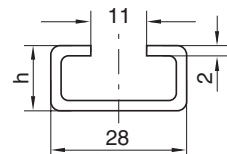
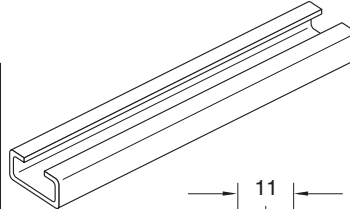

1 or 2 mtr

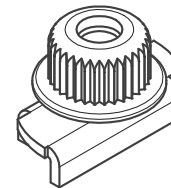
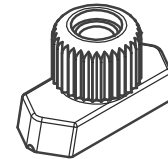
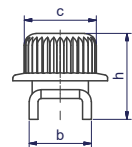
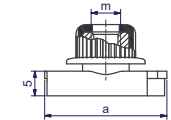
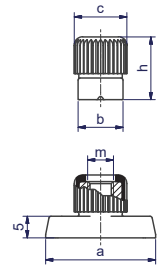
 With loss protection
(See page T54).

clamp size	weld plate, angled		mounting rail		rail nut	
	APWA A... Order code	dimensions: d e	TS...A/B Order code	dimensions: h	TM...A/B1 Order code	dimensions: a b c m h
0	APWA0X APWA04571X	14 30	TS11A/B1...* TS11A/B2...* TS14A/B1...* TS14A/B2...* TS30A/B1...* TS30A/B2...*	TS11: 11 TS14: 14 TS30: 30	TMA/TMB1VERZX TMA/TMB1/4571X	25.410.4 12 M6 14.5
1	APWA1X APWA14571X	20 36				
2	APWA2X APWA24571X	26 42				
3	APWA3X APWA34571X	33 50			TMA/TMB1WLPVZX TMA/TMB1WLP71X	24.910.5 12 M6 14.5
4	APWA4X APWA44571X	40 59				
5	APWA5X APWA54571X	52 72				
6	APWA6X APWA64571X	66 88				

*Please add the suffix below according to the surface/material required.

Order code suffixes		
Surface/material	Suffix	Example
Steel, phosphated	X	TS11A/B1X
Steel, zinc plated, Cr(VI)-free	VZX	TS11A/B1VZX
Stainless Steel 1.4571	71X	TS11A/B171X

Tube clamps series A (Light construction series) – Components

DIN 3015, part 1

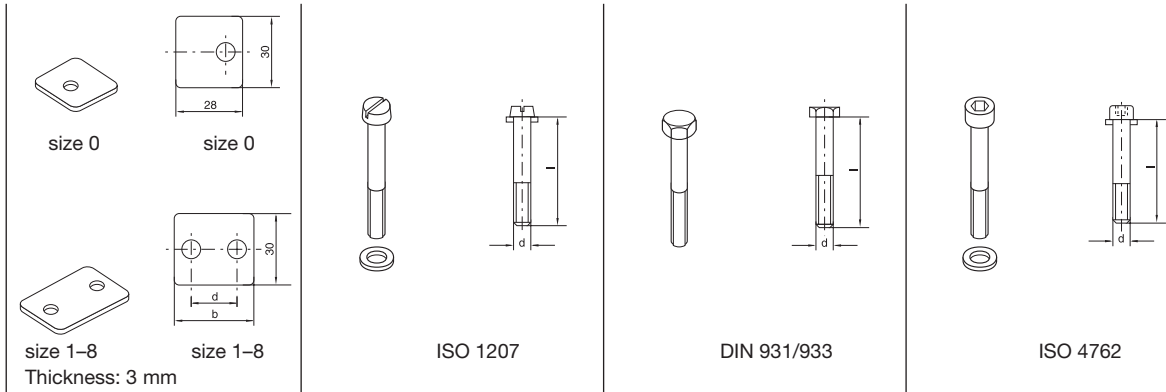

clamp size	cover plate		slot head		hexagon head		socket head	
	DP A... Order code	dimensions: b d	SL A... Order code	dimensions: d x L	SSL A... Order code	dimensions: d x L	IS A... Order code	dimensions: d x L
0	DPA0...*	- -	SLA0...*	M 06x20	SSLA0...*	M 06x30	ISA0...*	M 06x20
1	DPA1...*	34 20	SLA0...*	M 06x20	SSLA0...*	M 06x30	ISA0...*	M 06x20
2	DPA2...*	40 26	SLA2...*	M 06x25	SSLA2/SSB1...*	M 06x35	ISA2...*	M 06x25
3	DPA3...*	48 33	SLA3...*	M 06x30	SSLA3...*	M 06x40	ISA3...*	M 06x30
4	DPA4...*	57 40	SLA4...*	M 06x35	SSLA4...*	M 06x45	ISA4...*	M 06x35
5	DPA5...*	70 52	SLA5...*	M 06x50	SSLA5...*	M 06x60	ISA5...*	M 06x50
6	DPA6...*	86 66	SLA6...*	M 06x60	SSLA6...*	M 06x70	ISA6...*	M 06x60
7	DPA7...*	120 94	SLA7...*	M 06x90	SSLA7...*	M 06x100	ISA7...*	M 06x90
8	DPA8...*	146 120	SLA8...*	M 06x110	SSLA8...*	M 06x125	ISA8...*	M 06x110

*Please add the suffix below according to the surface/material required.

Order code suffixes		
Surface/material	Suffix	Example
Steel, zinc plated, Cr(VI)-free	X	DPA0X
Stainless Steel 1.4571	4571X	DPA04571X

Tube clamps series A (Light construction series) – Components

DIN 3015, part 1

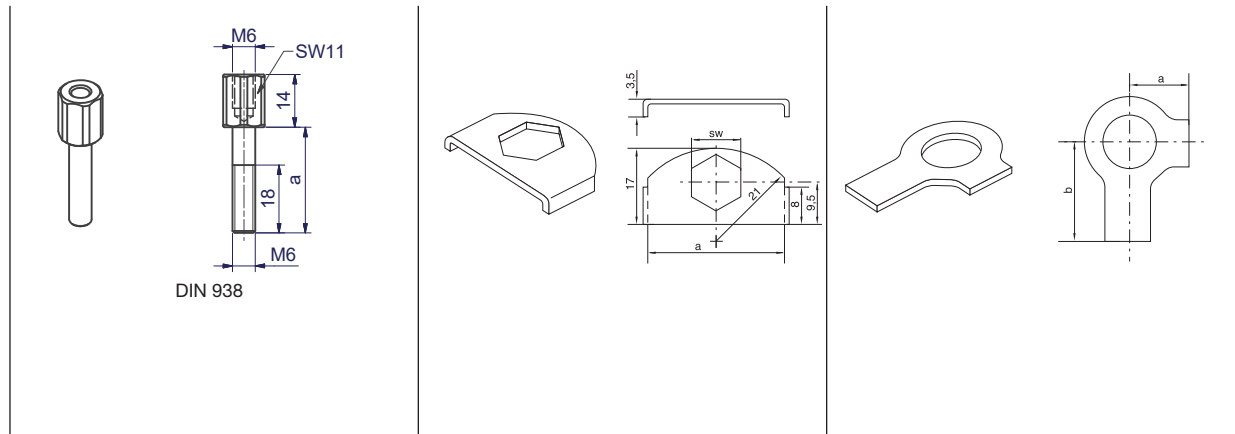

clamp size	stacking ¹⁾		locking plate ¹⁾		locking washer ²⁾	
	AS A... Order code	dimensions: a	SB A Order code	dimensions: a SW	US A Order code	dimensions: a b
0	ASA0...* (ASB1...*)	20	SBA...*	30 11	USA/USB1X ³⁾	9 18
1	ASA0...* (ASB1...*)	20				
2	ASA2...*	25				
3	ASA3...*	28				
4	ASA4...*	34				
5	ASA5...*	50				
6	ASA6...*	60				
7	ASA7...*	85				
8	ASA8...*	110				

¹⁾ The use of stacking bolts necessitates the use of locking plates in the construction assembly.

²⁾ When assembling solid rubber clamps, cover plates, hexagon screws and locking washers must be used.

³⁾ Material = stainless steel 1.4571

*Please add the suffix below according to the surface/material required.

Order code suffixes		
Surface/material	Suffix	Example
Steel, zinc plated, Cr(VI)-free	X	DPA0X
Stainless Steel 1.4571	4571X	DPA04571X

Tube clamps series A (Light construction series) – Complete range

Order codes for clamp halves:

Material	Interior surface	Order code
Polypropylene	grooved	RAP
	smooth	RAPG
Polyamide	grooved	RAN
	smooth	RANG
Rubber	smooth	RAVG¹⁾
Aluminium	grooved	RAA²⁾

(Please exchange as required standard abbreviation RAP in column for "Order code")

For flame- or corrosion retardant materials, please refer to page T5.

The steel parts of kits 1, 2 and 3 have the following surfaces:

Screws, bushes, cover plates = Cr(VI)-free galvanized

Welding plate = phosphated

Other compositions available on request.

2 clamp halves, weld plate **short**, slot head bolts and bushes

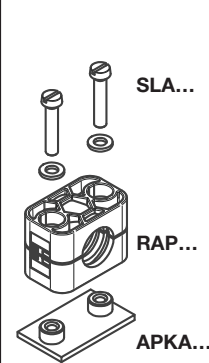

2 clamp halves, weld plate **short**, socket head bolts and bushes

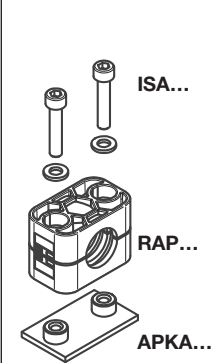

2 clamp halves, weld plate **short**, cover plate hex. head bolts

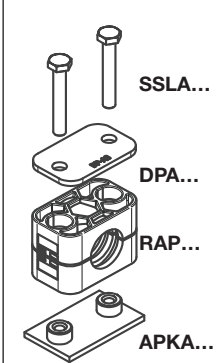

clamp size	Tube O.D. mm	Tube NB	Tube O.D.	Order code	Order code	Order code		
0 ³⁾	4.0	G 1/8	1/4 5/16 3/8	RAP1-004	RAP2-004	RAP3-004		
	6.0			RAP1-006	RAP2-006	RAP3-006		
	6.4			RAP1-006.4	RAP2-006.4	RAP3-006.4		
	8.0			RAP1-008	RAP2-008	RAP3-008		
	9.5			RAP1-009.5	RAP2-009.5	RAP3-009.5		
	10.0			RAP1-010	RAP2-010	RAP3-010		
1	12.0	G 1/8	1/4 5/16 3/8	RAP1-012	RAP2-012	RAP3-012		
	4.0			RAP1-104	RAP2-104	RAP3-104		
	6.0			RAP1-106	RAP2-106	RAP3-106		
	6.4			RAP1-106.4	RAP2-106.4	RAP3-106.4		
	8.0			RAP1-108	RAP2-108	RAP3-108		
	9.5			RAP1-109.5	RAP2-109.5	RAP3-109.5		
2	10.0	G 3/8	1/2 5/8	RAP1-110	RAP2-110	RAP3-110		
	12.0			RAP1-112	RAP2-112	RAP3-112		
	12.7			G 1/4	1/2	RAP1-212.7	RAP2-212.7	RAP3-212.7
	13.5					RAP1-213.5	RAP2-213.5	RAP3-213.5
	14.0					RAP1-214	RAP2-214	RAP3-214
	15.0					RAP1-215	RAP2-215	RAP3-215
16.0	RAP1-216	RAP2-216	RAP3-216					
17.2	RAP1-217.2	RAP2-217.2	RAP3-217.2					
3	18.0	G 1/2	3/4 1	RAP1-218	RAP2-218	RAP3-218		
	19.0			RAP1-319	RAP2-319	RAP3-319		
	20.0			RAP1-320	RAP2-320	RAP3-320		
	21.3			RAP1-321.3	RAP2-321.3	RAP3-321.3		
	22.0			RAP1-322	RAP2-322	RAP3-322		
	23.0			RAP1-323	RAP2-323	RAP3-323		
4	25.0	G 3/4	1	RAP1-325	RAP2-325	RAP3-325		
	25.4			RAP1-325.4	RAP2-325.4	RAP3-325.4		
	26.9			RAP1-426.9	RAP2-426.9	RAP3-426.9		
	28.0			RAP1-428	RAP2-428	RAP3-428		
5	30.0	G 1	1 1/4 1 1/2	RAP1-430	RAP2-430	RAP3-430		
	32.0			RAP1-532	RAP2-532	RAP3-532		
	33.7			RAP1-533.7	RAP2-533.7	RAP3-533.7		
	35.0			RAP1-535	RAP2-535	RAP3-535		
	38.0			RAP1-538	RAP2-538	RAP3-538		
	40.0			RAP1-540	RAP2-540	RAP3-540		
6	42.0	G 1 1/4	1 3/4 2	RAP1-542	RAP2-542	RAP3-542		
	44.5			RAP1-644.5	RAP2-644.5	RAP3-644.5		
	45.0			RAP1-645	RAP2-645	RAP3-645		
	48.0			RAP1-648	RAP2-648	RAP3-648		
	50.0			RAP1-650	RAP2-650	RAP3-650		
	50.8			RAP1-650.8	RAP2-650.8	RAP3-650.8		
	52.0			RAP1-652	RAP2-652	RAP3-652		
	54.0			RAP1-654	RAP2-654	RAP3-654		
55.0	RAP1-655	RAP2-655	RAP3-655					
57.0	RAP1-657	RAP2-657	RAP3-657					

Continuation see next page ...

Tube clamps series A (Light construction series) – Complete range

Order codes for clamp halves:

Material	Interior surface	Order code
Polypropylene	grooved	RAP
	smooth	RAPG
Polyamide	grooved	RAN
	smooth	RANG
Rubber	smooth	RAVG¹⁾
Aluminium	grooved	RAA²⁾

(Please exchange as required standard abbreviation RAP in column for "Order code")

For flame- or corrosion retardant materials, please refer to page T5.

The steel parts of kits 1, 2 and 3 have the following surfaces:

Screws, bushes, cover plates = Cr(VI)-free galvanized

Welding plate = phosphated

Other compositions available on request.

2 clamp halves, weld plate **short**, slot head bolts and bushes

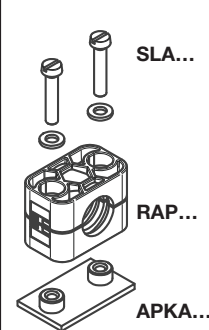

2 clamp halves, weld plate **short**, socket head bolts and bushes

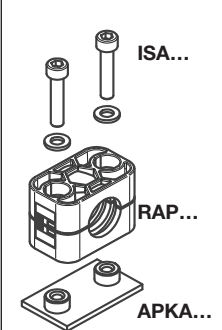

2 clamp halves, weld plate **short**, cover plate hex. head bolts

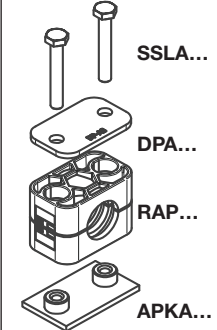

clamp size	Tube O.D. mm	Tube NB	Tube O.D.	Order code	Order code	Order code
7	57.2	G 2	2 1/4	RAP1-757.2	RAP2-757.2	RAP3-757.2
	60.3		2 1/2	RAP1-760.3	RAP2-760.3	RAP3-760.3
	63.5		2 3/4	RAP1-763.5	RAP2-763.5	RAP3-763.5
	70.0	G 2 1/2	3	RAP1-770	RAP2-770	RAP3-770
	73.0			RAP1-773	RAP2-773	RAP3-773
	76.1			RAP1-776.1	RAP2-776.1	RAP3-776.1
8	88.9	G 3	4	RAP1-888.9	RAP2-888.9	RAP3-888.9
	101.8			RAP1-8101.8	RAP2-8101.8	RAP3-8101.8

Delivery in unassembled individual components.

¹⁾ When assembling solid rubber clamps, cover plates, hexagon screws and locking washers must be used.

²⁾ Aluminium size 0-6.

³⁾ Contrary to the illustration size 0 clamps are secured by only one screw.

Tube clamps series A (Light construction series) – Complete range

Order codes for clamp halves:

Material	Interior surface	Order code
Polypropylene	grooved	RAP
	smooth	RAPG
Polyamide	grooved	RAN
	smooth	RANG
Rubber	smooth	RAVG¹⁾
Aluminium	grooved	RAA²⁾

(Please exchange as required standard abbreviation RAP in column for "Order code")

For flame- or corrosion retardant materials, please refer to page T5.

The steel parts of kits 4, 5 and 6 have the following surfaces:

Screws, bushes, cover plates = Cr(VI)-free galvanized

Welding plate = phosphated

Other compositions available on request.

2 clamp halves, weld/
screw plate, slot head
bolts and bushes

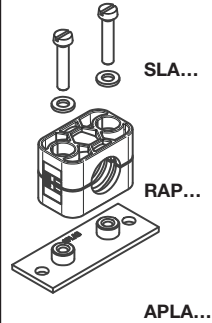

2 clamp halves, weld/
screw plate, socket
head bolts and bushes

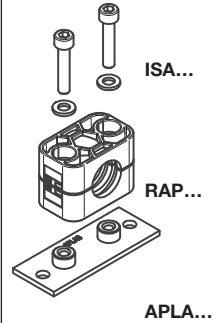

2 clamp halves, weld/
screw plate, cover
plate and hex. head
bolts

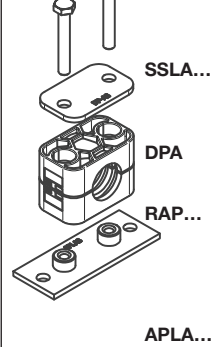

clamp size	Tube O.D. mm	Tube NB	Tube O.D.	Order code	Order code	Order code		
0 ³⁾	4.0	G 1/8	1/4 5/16 3/8	RAP4-004	RAP5-004	RAP6-004		
	6.0			RAP4-006	RAP5-006	RAP6-006		
	6.4			RAP4-006.4	RAP5-006.4	RAP6-006.4		
	8.0			RAP4-008	RAP5-008	RAP6-008		
	9.5			RAP4-009.5	RAP5-009.5	RAP6-009.5		
	10.0			RAP4-010	RAP5-010	RAP6-010		
1	12.0	G 1/8	1/4 5/16 3/8	RAP4-012	RAP5-012	RAP6-012		
	4.0			RAP4-104	RAP5-104	RAP6-104		
	6.0			RAP4-106	RAP5-106	RAP6-106		
	6.4			RAP4-106.4	RAP5-106.4	RAP6-106.4		
	8.0			RAP4-108	RAP5-108	RAP6-108		
	9.5			RAP4-109.5	RAP5-109.5	RAP6-109.5		
2	10.0	G 3/8	1/2 5/8	RAP4-110	RAP5-110	RAP6-110		
	12.0			RAP4-112	RAP5-112	RAP6-112		
	12.7			G 1/4	1/2	RAP4-212.7	RAP5-212.7	RAP6-212.7
	13.5					RAP4-213.5	RAP5-213.5	RAP6-213.5
	14.0					RAP4-214	RAP5-214	RAP6-214
	15.0					RAP4-215	RAP5-215	RAP6-215
16.0	RAP4-216	RAP5-216	RAP6-216					
17.2	RAP4-217.2	RAP5-217.2	RAP6-217.2					
3	18.0	G 1/2	3/4 1	RAP4-218	RAP5-218	RAP6-218		
	19.0			RAP4-319	RAP5-319	RAP6-319		
	20.0			RAP4-320	RAP5-320	RAP6-320		
	21.3			RAP4-321.3	RAP5-321.3	RAP6-321.3		
	22.0			RAP4-322	RAP5-322	RAP6-322		
	23.0			RAP4-323	RAP5-323	RAP6-323		
4	25.0	G 3/4	1	RAP4-325	RAP5-325	RAP6-325		
	25.4			RAP4-325.4	RAP5-325.4	RAP6-325.4		
	26.9			RAP4-426.9	RAP5-426.9	RAP6-426.9		
5	28.0	G 1	1 1/4 1 1/2	RAP4-428	RAP5-428	RAP6-428		
	30.0			RAP4-430	RAP5-430	RAP6-430		
	32.0			G 1 1/4	1 1/4	RAP4-532	RAP5-532	RAP6-532
	33.7					RAP4-533.7	RAP5-533.7	RAP6-533.7
	35.0					RAP4-535	RAP5-535	RAP6-535
	38.0					RAP4-538	RAP5-538	RAP6-538
40.0	RAP4-540	RAP5-540	RAP6-540					
42.0	RAP4-542	RAP5-542	RAP6-542					
6	44.5	G 1 1/2	1 3/4 2	RAP4-644.5	RAP5-644.5	RAP6-644.5		
	45.0			RAP4-645	RAP5-645	RAP6-645		
	48.0			RAP4-648	RAP5-648	RAP6-648		
	50.0			RAP4-650	RAP5-650	RAP6-650		
	50.8			RAP4-650.8	RAP5-650.8	RAP6-650.8		
	52.0			RAP4-652	RAP5-652	RAP6-652		
	54.0			RAP4-654	RAP5-654	RAP6-654		
	55.0			RAP4-655	RAP5-655	RAP6-655		
	57.0			RAP4-657	RAP5-657	RAP6-657		

Continuation see next page ...

Tube clamps series A (Light construction series) – Complete range

Order codes for clamp halves:

Material	Interior surface	Order code
Polypropylene	grooved	RAP
	smooth	RAPG
Polyamide	grooved	RAN
	smooth	RANG
Rubber	smooth	RAVG¹⁾
Aluminium	grooved	RAA²⁾

(Please exchange as required standard abbreviation RAP in column for "Order code")

For flame- or corrosion retardant materials, please refer to page T5.

The steel parts of kits 4, 5 and 6 have the following surfaces:

Screws, bushes, cover plates = Cr(VI)-free galvanized

Welding plate = phosphated

Other compositions available on request.

2 clamp halves, weld/
screw plate, slot head
bolts and bushes

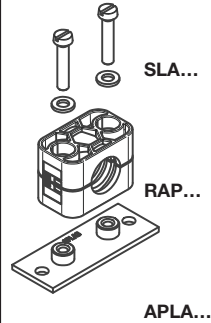

2 clamp halves, weld/
screw plate, socket
head bolts and bushes

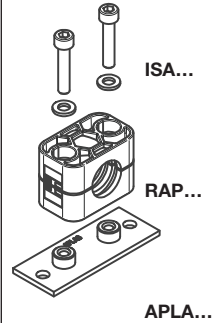

2 clamp halves, weld/
screw plate, cover
plate and hex. head
bolts

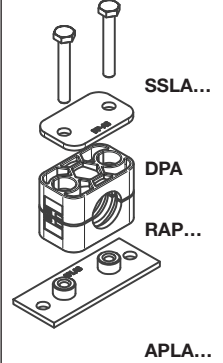

clamp size	Tube O.D. mm	Tube NB	Tube O.D.	Order code	Order code	Order code
7	57.2	G 2	2 1/4	RAP4-757.2	RAP5-757.2	RAP6-757.2
	60.3		2 1/2	RAP4-760.3	RAP5-760.3	RAP6-760.3
	63.5		2 3/4	RAP4-763.5	RAP5-763.5	RAP6-763.5
	70.0	G 2 1/2	3	RAP4-770	RAP5-770	RAP6-770
	73.0			RAP4-773	RAP5-773	RAP6-773
	76.1			RAP4-776.1	RAP5-776.1	RAP6-776.1
8	88.9	G 3	3 1/2	RAP4-888.9	RAP5-888.9	RAP6-888.9
	101.8		4	RAP4-8101.8	RAP5-8101.8	RAP6-8101.8

Delivery in unassembled individual components.

¹⁾ When assembling solid rubber clamps, cover plates, hexagon screws and locking washers must be used.

²⁾ Aluminium size 0-6.

³⁾ Contrary to the illustration size 0 clamps are secured by only one screw.

Tube clamps

Tube clamps series A (Light construction series) – Complete range
Order codes for clamp halves:

Material	Interior surface	Order code
Polypropylene	grooved	RAP
	smooth	RAPG
Polyamide	grooved	RAN
	smooth	RANG
Rubber	smooth	RAVG ¹⁾
Aluminium	grooved	RAA ²⁾

(Please exchange as required standard abbreviation RAP in column for "Order code")

For flame- or corrosion retardant materials, please refer to page T5.

The steel parts of kits 9, 10 and 12 have the following surfaces:

Screws, bushes, cover plates = Cr(VI)-free galvanized

Welding plate = phosphated

Other compositions available on request.

2 clamp halves, rail nuts, slot head bolts and bushes

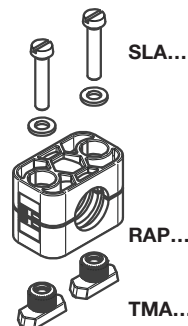

2 clamp halves, rail nuts, socket head bolts and bushes

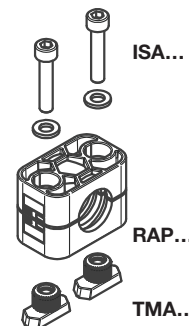

2 clamp halves, rail nuts, cover plate and hex. head bolts

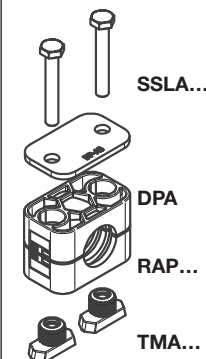

clamp size	Tube O.D. mm	Tube NB	Tube O.D.	Order code	Order code	Order code
0 ³⁾	4.0	G 1/8	1/4	RAP9-004	RAP10-004	RAP12-004
	6.0			RAP9-006	RAP10-006	RAP12-006
	6.4			RAP9-006.4	RAP10-006.4	RAP12-006.4
	8.0			RAP9-008	RAP10-008	RAP12-008
	9.5			RAP9-009.5	RAP10-009.5	RAP12-009.5
	10.0			RAP9-010	RAP10-010	RAP12-010
1	12.0	G 1/8	3/8	RAP9-012	RAP10-012	RAP12-012
	4.0			RAP9-104	RAP10-104	RAP12-104
	6.0			RAP9-106	RAP10-106	RAP12-106
	6.4			RAP9-106.4	RAP10-106.4	RAP12-106.4
	8.0			RAP9-108	RAP10-108	RAP12-108
	9.5			RAP9-109.5	RAP10-109.5	RAP12-109.5
2	10.0	G 3/8	5/8	RAP9-110	RAP10-110	RAP12-110
	12.0			RAP9-112	RAP10-112	RAP12-112
	12.7			RAP9-212.7	RAP10-212.7	RAP12-212.7
	13.5			RAP9-213.5	RAP10-213.5	RAP12-213.5
	14.0			RAP9-214	RAP10-214	RAP12-214
	15.0			RAP9-215	RAP10-215	RAP12-215
3	16.0	G 1/2	1	RAP9-216	RAP10-216	RAP12-216
	17.2			RAP9-217.2	RAP10-217.2	RAP12-217.2
	18.0			RAP9-218	RAP10-218	RAP12-218
	19.0			RAP9-319	RAP10-319	RAP12-319
	20.0			RAP9-320	RAP10-320	RAP12-320
	21.3			RAP9-321.3	RAP10-321.3	RAP12-321.3
4	22.0	G 3/4	1	RAP9-322	RAP10-322	RAP12-322
	23.0			RAP9-323	RAP10-323	RAP12-323
	25.0			RAP9-325	RAP10-325	RAP12-325
	25.4			RAP9-325.4	RAP10-325.4	RAP12-325.4
5	26.9	G 1	1 1/4	RAP9-426.9	RAP10-426.9	RAP12-426.9
	28.0			RAP9-428	RAP10-428	RAP12-428
	30.0			RAP9-430	RAP10-430	RAP12-430
	32.0			RAP9-532	RAP10-532	RAP12-532
	33.7			RAP9-533.7	RAP10-533.7	RAP12-533.7
	35.0			RAP9-535	RAP10-535	RAP12-535
6	38.0	G 1 1/4	2	RAP9-538	RAP10-538	RAP12-538
	40.0			RAP9-540	RAP10-540	RAP12-540
	42.0			RAP9-542	RAP10-542	RAP12-542
	44.5			RAP9-644.5	RAP10-644.5	RAP12-644.5
	45.0			RAP9-645	RAP10-645	RAP12-645
	48.0			RAP9-648	RAP10-648	RAP12-648
6	50.0	G 1 1/2	2	RAP9-650	RAP10-650	RAP12-650
	50.8			RAP9-650.8	RAP10-650.8	RAP12-650.8
	52.0			RAP9-652	RAP10-652	RAP12-652
	54.0			RAP9-654	RAP10-654	RAP12-654
	55.0			RAP9-655	RAP10-655	RAP12-655
	57.0			RAP9-657	RAP10-657	RAP12-657

Continuation see next page ...

Tube clamps series A (Light construction series) – Complete range

Order codes for clamp halves:

Material	Interior surface	Order code
Polypropylene	grooved	RAP
	smooth	RAPG
Polyamide	grooved	RAN
	smooth	RANG
Rubber	smooth	RAVG¹⁾
Aluminium	grooved	RAA²⁾

(Please exchange as required standard abbreviation RAP in column for "Order code")

For flame- or corrosion retardant materials, please refer to page T5.

The steel parts of kits 9, 10 and 12 have the following surfaces:

Screws, bushes, cover plates = Cr(VI)-free galvanized

Welding plate = phosphated

Other compositions available on request.

2 clamp halves, rail nuts, slot head bolts and bushes

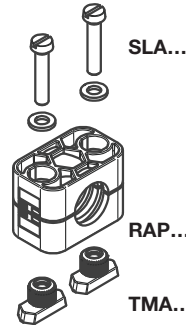

2 clamp halves, rail nuts, socket head bolts and bushes

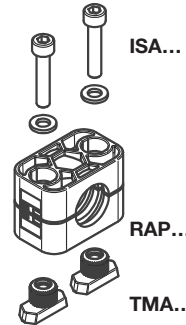

2 clamp halves, rail nuts, cover plate and hex. head bolts

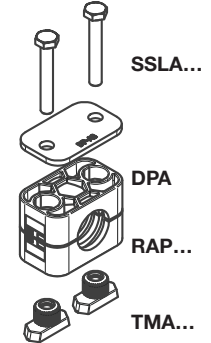

clamp size	Tube O.D. mm	Tube NB	Tube O.D.	Order code	Order code	Order code
7	57.2	G 2	2 1/4	RAP9-757.2	RAP10-757.2	RAP12-757.2
	60.3		2 1/2	RAP9-760.3	RAP10-760.3	RAP12-760.3
	63.5		2 3/4	RAP9-763.5	RAP10-763.5	RAP12-763.5
	70.0			RAP9-770	RAP10-770	RAP12-770
	73.0	G 2 1/2	3	RAP9-773	RAP10-773	RAP12-773
	76.1		RAP9-776.1	RAP10-776.1	RAP12-776.1	
8	88.9	G 3	3 1/2	RAP9-888.9	RAP10-888.9	RAP12-888.9
	101.8		4	RAP9-8101.8	RAP10-8101.8	RAP12-8101.8

Delivery in unassembled individual components.

¹⁾ When assembling solid rubber clamps, cover plates, hexagon screws and locking washers must be used.

²⁾ Aluminium size 0-6.

³⁾ Contrary to the illustration size 0 clamps are secured by only one screw.

Tube clamps series A – Complete range

Order codes for clamp halves:

Material	Interior surface	Order code
Polypropylene	grooved	RAP
	smooth	RAPG
Polyamide	grooved	RAN
	smooth	RANG
Rubber	smooth	RAVG¹⁾
Aluminium	grooved	RAA²⁾

(Please exchange as required standard abbreviation RAP in column for "Order code")

For flame- or corrosion retardant materials, please refer to page T5.

The steel parts of kits 13 and 14 have the following surfaces:

Screws, bushes, cover plates = Cr(VI)-free galvanized

Welding plate = phosphated

Other compositions available on request.

2 clamp halves, slot heads and bushes

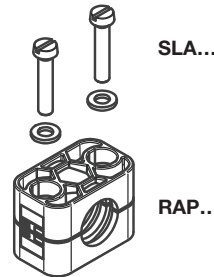

2 clamp halves, socket head bolts and bushes

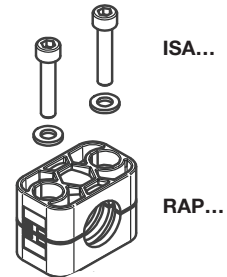

clamp size	Tube O.D. mm	Tube NB	Tube O.D.	Order code	Order code		
0 ³⁾	4.0	G 1/8	1/4	RAP13-004	RAP14-004		
	6.0			RAP13-006	RAP14-006		
	6.4			RAP13-006.4	RAP14-006.4		
	8.0			RAP13-008	RAP14-008		
	9.5			RAP13-009.5	RAP14-009.5		
	10.0			RAP13-010	RAP14-010		
1	12.0	G 1/8	3/8	RAP13-012	RAP14-012		
	4.0			RAP13-104	RAP14-104		
	6.0			RAP13-106	RAP14-106		
	6.4			RAP13-106.4	RAP14-106.4		
	8.0			RAP13-108	RAP14-108		
	9.5			RAP13-109.5	RAP14-109.5		
2	10.0	G 3/8	5/8	RAP13-110	RAP14-110		
	12.0			RAP13-112	RAP14-112		
	12.7			G 1/4	1/2	RAP13-212.7	RAP14-212.7
	13.5					RAP13-213.5	RAP14-213.5
	14.0					RAP13-214	RAP14-214
	3			15.0	G 1/2	3/4	RAP13-215
16.0		RAP13-216	RAP14-216				
17.2		G 3/8	5/8	RAP13-217.2			RAP14-217.2
18.0				RAP13-218			RAP14-218
19.0				G 1/2			1
20.0		RAP13-320	RAP14-320				
21.3	RAP13-321.3	RAP14-321.3					
4	22.0	G 3/4	1 1/4	RAP13-322	RAP14-322		
	23.0			RAP13-323	RAP14-323		
	25.0			G 1/2	1	RAP13-325	RAP14-325
	25.4					RAP13-325.4	RAP14-325.4
	26.9					G 1/4	1/2
	28.0			RAP13-428	RAP14-428		
30.0	RAP13-430	RAP14-430					
5	32.0	G 1	1 1/2	RAP13-532	RAP14-532		
	33.7			RAP13-533.7	RAP14-533.7		
	35.0			G 1 1/4	1 1/2	RAP13-535	RAP14-535
	38.0					RAP13-538	RAP14-538
	40.0					RAP13-540	RAP14-540
	42.0			RAP13-542	RAP14-542		
6	44.5	G 1 1/2	2	RAP13-644.5	RAP14-644.5		
	45.0			RAP13-645	RAP14-645		
	48.0			RAP13-648	RAP14-648		
	50.0			RAP13-650	RAP14-650		
	50.8			RAP13-650.8	RAP14-650.8		
	52.0			RAP13-652	RAP14-652		
	54.0			RAP13-654	RAP14-654		
	55.0			RAP13-655	RAP14-655		
	57.0			RAP13-657	RAP14-657		

Continuation see next page ...

Tube clamps series A – Complete range

Order codes for clamp halves:

Material	Interior surface	Order code
Polypropylene	grooved	RAP
	smooth	RAPG
Polyamide	grooved	RAN
	smooth	RANG
Rubber	smooth	RAVG¹⁾
Aluminium	grooved	RAA²⁾

(Please exchange as required standard abbreviation RAP in column for "Order code")

For flame- or corrosion retardant materials, please refer to page T5.

The steel parts of kits 13 and 14 have the following surfaces:

Screws, bushes, cover plates = Cr(VI)-free galvanized

Welding plate = phosphated

Other compositions available on request.

2 clamp halves, slot heads and bushes

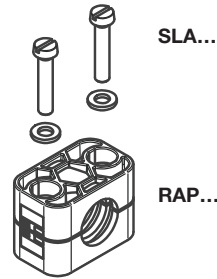

2 clamp halves, socket head bolts and bushes

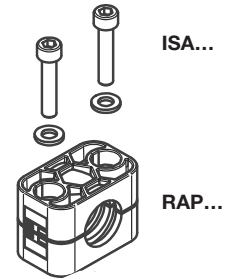

clamp size	Tube O.D. mm	Tube NB	Tube O.D.	Order code	Order code
7	57.2	G 2	2 1/4	RAP13-757.2	RAP14-757.2
	60.3		2 1/2	RAP13-760.3	RAP14-760.3
	63.5		2 3/4	RAP13-763.5	RAP14-763.5
	70.0	G 2 1/2	3	RAP13-770	RAP14-770
	73.0		RAP13-773	RAP14-773	
8	76.1	G3	3 1/2	RAP13-776.1	RAP14-776.1
	88.9		4	RAP13-888.9	RAP14-888.9
	101.8		RAP13-8101.8	RAP14-8101.8	

Delivery in unassembled individual components.

¹⁾ When assembling solid rubber clamps, cover plates, hexagon screws and locking washers must be used.

²⁾ Aluminium size 0-6.

³⁾ Contrary to the illustration size 0 clamps are secured by only one screw.

Tube clamps

Tube clamps series A – Complete range

Order codes for clamp halves:

Material	Interior surface	Order code
Polypropylene	grooved	RAP
	smooth	RAPG
Polyamide	grooved	RAN
	smooth	RANG
Rubber	smooth	RAVG ¹⁾
Aluminium	grooved	RAA ²⁾

(Please exchange as required standard abbreviation RAP in column for "Order code")

For flame- or corrosion retardant materials, please refer to page T5.

The steel parts of kits 16 and 18 have the following surfaces:

Screws, bushes, cover plates = Cr(VI)-free galvanized

Welding plate = phosphated

Other compositions available on request.

2 clamp halves, cover plate and hex. head bolts

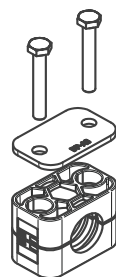

SSLA...

DPA...

RAP...

2 clamp halves, stacking bolts and locking plate

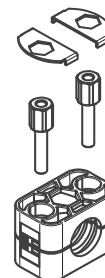

SBA...

ASA...

RAP...

clamp size	Tube O.D. mm	Tube NB	Tube O.D.	Order code	Order code
0 ³⁾	4.0	G 1/8	1/4	RAP16-004	RAP18-004
	6.0			RAP16-006	RAP18-006
	6.4			RAP16-006.4	RAP18-006.4
	8.0			RAP16-008	RAP18-008
	9.5			RAP16-009.5	RAP18-009.5
	10.0			RAP16-010	RAP18-010
1	12.0	G 1/8	3/8	RAP16-012	RAP18-012
	4.0			RAP16-104	RAP18-104
	6.0			RAP16-106	RAP18-106
	6.4			RAP16-106.4	RAP18-106.4
	8.0			RAP16-108	RAP18-108
	9.5			RAP16-109.5	RAP18-109.5
2	10.0	G 3/8	5/8	RAP16-110	RAP18-110
	12.0			RAP16-112	RAP18-112
	12.7			RAP16-212.7	RAP18-212.7
	13.5			RAP16-213.5	RAP18-213.5
	14.0			RAP16-214	RAP18-214
	15.0			RAP16-215	RAP18-215
3	16.0	G 1/2	1	RAP16-216	RAP18-216
	17.2			RAP16-217.2	RAP18-217.2
	18.0			RAP16-218	RAP18-218
	19.0			RAP16-319	RAP18-319
	20.0			RAP16-320	RAP18-320
	21.3			RAP16-321.3	RAP18-321.3
4	22.0	G 3/4	1 1/4	RAP16-322	RAP18-322
	23.0			RAP16-323	RAP18-323
	25.0			RAP16-325	RAP18-325
	25.4			RAP16-325.4	RAP18-325.4
	26.9			RAP16-426.9	RAP18-426.9
	28.0			RAP16-428	RAP18-428
5	30.0	G 1	1 1/2	RAP16-430	RAP18-430
	32.0			RAP16-532	RAP18-532
	33.7			RAP16-533.7	RAP18-533.7
	35.0			RAP16-535	RAP18-535
	38.0			RAP16-538	RAP18-538
	40.0			RAP16-540	RAP18-540
6	42.0	G 1 1/4	2	RAP16-542	RAP18-542
	44.5			RAP16-644.5	RAP18-644.5
	45.0			RAP16-645	RAP18-645
	48.0			RAP16-648	RAP18-648
	50.0			RAP16-650	RAP18-650
	50.8			RAP16-650.8	RAP18-650.8
	52.0	G 1 1/2	2	RAP16-652	RAP18-652
	54.0			RAP16-654	RAP18-654
	55.0			RAP16-655	RAP18-655
	57.0			RAP16-657	RAP18-657

Continuation see next page ...

Tube clamps series A – Complete range

Order codes for clamp halves:

Material	Interior surface	Order code
Polypropylene	grooved	RAP
	smooth	RAPG
Polyamide	grooved	RAN
	smooth	RANG
Rubber	smooth	RAVG¹⁾
Aluminium	grooved	RAA²⁾

(Please exchange as required standard abbreviation RAP in column for "Order code")

For flame- or corrosion retardant materials, please refer to page T5.

The steel parts of kits 16 and 18 have the following surfaces:

Screws, bushes, cover plates = Cr(VI)-free galvanized

Welding plate = phosphated

Other compositions available on request.

2 clamp halves, cover plate and hex. head bolts



SSLA

DPA...

RAP...

2 clamp halves, stacking bolts and locking plate

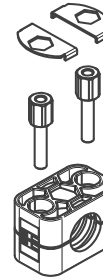

SBA...

ASA...

RAP...

clamp size	Tube O.D. mm	Tube NB	Tube O.D.	Order code	Order code
7	57.2	G 2	2 1/4	RAP16-757.2	RAP18-757.2
	60.3		2 1/2	RAP16-760.3	RAP18-760.3
	63.5		2 3/4	RAP16-763.5	RAP18-763.5
	70.0		RAP16-770	RAP18-770	
	73.0	G 2 1/2	3	RAP16-773	RAP18-773
	76.1		RAP16-776.1	RAP18-776.1	
8	88.9	G 3	3 1/2	RAP16-888.9	RAP18-888.9
	101.8		4	RAP16-8101.8	RAP18-8101.8

Delivery in unassembled individual components.

¹⁾ When assembling solid rubber clamps, cover plates, hexagon screws and locking washers must be used.

²⁾ Aluminium sizes 0-6.

³⁾ Contrary to the illustration size 0 clamps are secured by only one screw.

Tube clamps

Tube clamps series B (Twin-tube clamps) – Components

DIN 3015, part 3

Order codes for clamp halves:

Material	Interior surface	Order code
Polypropylene	grooved	RBP
	smooth	RBPG
Polyamide	grooved	RBN
	smooth	RBNG
Rubber	smooth	RBVG¹⁾

(Please exchange as required standard abbreviation RBP in column for "clamp halves")

For flame- or corrosion retardant materials, please refer to page T5.

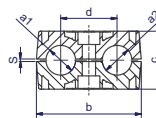
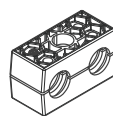

Width: 30 mm

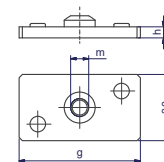
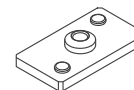

clamp size	Tube O.D. mm	Tube NB	Tube O.D.	1 part 2 clamp halves ²⁾		weld plate with locking device			
				RBP... Order code	dimensions: b c d s	APB... Order code	dimensions: g m h		
1	6.0	G 1/8	1/4 5/16 3/8	RBP106X RBP106.4X RBP108X RBP109.5X RBP110X RBP112X	36 27.0 20 1.0	APB1...*	37	M6	3
	6.4								
	8.0								
	9.5								
	10.0								
	12.0								
2	12.7	G 1/4 G 3/8	1/2 5/8	RBP212.7X RBP213.5X RBP214X RBP215X RBP216X RBP217.2X RBP218X	53 27.4 29 1.2	APB2...*	55	M8	5
	13.5								
	14.0								
	15.0								
	16.0								
	17.2								
3	19.0	G 1/2	3/4 1	RBP319X RBP320X RBP321.3X RBP322X RBP325X RBP325.4X	67 37.0 36 1.6	APB3...*	70	M8	5
	20.0								
	21.3								
	22.0								
	25.0								
	25.4								
4	26.9	G 3/4		RBP426.9X RBP428X RBP430X	82 42.0 45 2.0	APB4...*	85	M8	5
	28.0								
	30.0								
5	32.0	G 1 G 1 1/4	1 1/4 1 1/2	RBP532X RBP533.7X RBP535X RBP538X RBP540X RBP542X	106 54.0 56 2.0	APB5...*	110	M8	5
	33.7								
	35.0								
	38.0								
	40.0								
	42.0								

¹⁾ When assembling solid rubber clamps, cover plates, hexagon screws and locking washers must be used.

²⁾ Twin-tube clamps with different outer tube diameters upon request.

*Please add the suffix below according to the surface/material required.

Order code suffixes		
Surface/material	Suffix	Example
Steel, phosphated	X	APB1X
Steel, zinc plated, Cr(VI)-free	VZX	APB1VZX
Stainless Steel 1.4571	4571X	APB14571X

Tube clamps series B (Twin-tube clamps) – Components

DIN 3015, part 3

clamp size	weld plate, angled		mounting rail nut					mounting rail nut						
	TS...A/B Order code	dimensions: h	TM Order code	dimensions: a b c m h					TMA/TMB1... Order code	dimensions: a b c m h				
1			TMA/TMB1VERZX TMA/TMB1/4571X	25.4	10.4	12	M6	14.5	TMA/TMB1WLPVZX TMA/TMB1WLP71X	25.4	10.4	12	M6	14.5
2	TS11A/B1...* TS11A/B2...* TS14A/B1...* TS14B/B2...* TS30A/B1...* TS30B/B2...*	TS11: TS14: TS30:	TMB2VZX TMB24571X	25.4	10.4	14	M8	13.0						
3														
4														
5														

*Please add the suffix below according to the surface/material required.

Order code suffixes		
Surface/material	Suffix	Example
Steel, phosphated	X	TS11A/B1X
Steel, zinc plated, Cr(VI)-free	VZX	TS11A/B1VZX
Stainless Steel 1.4571	71X	TS11A/B171X

Tube clamps series B (Twin-tube clamps) – Components

DIN 3015, part 3

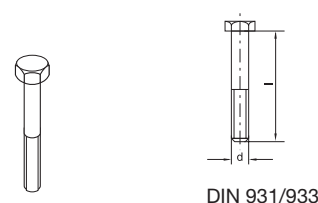
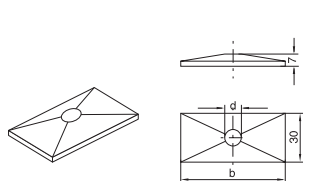
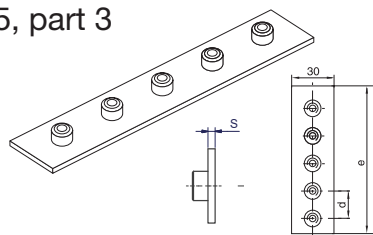

clamp size	weld plate angled (5 clamps)			cover plate			hexagonal screws		
	APR B... Order code	dimensions: d e		s	DP B... Order code	dimensions: b d		SS B... Order code	dimensions: d x L
1	APRB1X APRB1VZX APRB4571X	40	196	3	DPB1...*	34	6.6	SSLA2/SSB1...*	M 06x35
2	APRB2X APRB2VZX APRB24571X	58	288	5	DPB2...*	51	8.6	SSB2...*	M 08x35
3	APRB3X APRB3VZX APRB34571X	72	358	5	DPB3...*	64	8.6	SSB3...*	M 08x45
4	APRB4X APRB4VZX APRB44571X	90	446	5	DPB4...*	78	8.6	SSB4...*	M 08x50
5	APRB5X APRBVZX APRB4571X	112	558	5	DPB5...*	102	8.6	SSB5...*	M 08x60

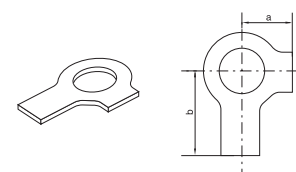
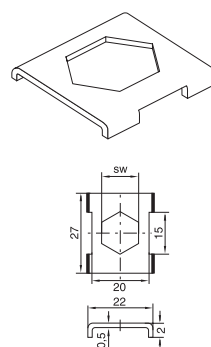
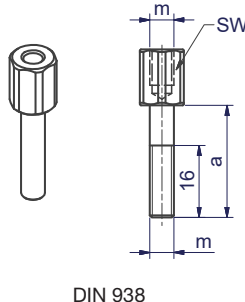
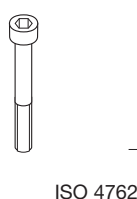

clamp size	socket head		stacking			locking plate ¹⁾		locking washer ²⁾	
	IS B... Order code	dimensions: d x L	AS B... Order code	dimensions: a m SW		SB B... Order code	dim.: SW	US... Order code	dimensions: a b
1	ISA4...* (ISB1...*)	M 06x35	ASA0...* (ASB1...*)	20	M6 11	SBB1...*	11	USA/USB1X ³⁾	9 18
2	ISB2...*	M 08x35	ASB2...*	22	M8 12	SBB2...*	12	USB2X USB271X	11 20
3	ISB3...*	M 08x45	ASB3...*	30	M8 12				
4	ISB4...*	M 08x50	ASB4...*	35	M8 12				
5	ISB5...*	M 08x60	ASB5...*	47	M8 12				

1) The use of stacking screws necessitates the use of locking plates in the construction assembly!

2) When assembling solid rubber clamps, covering plates, hexagon screws and locking washers must be used.

3) Material = Stainless steel 1.4571

*Please add the suffix below according to the surface/material required.

Order code suffixes		
Surface/material	Suffix	Example
Steel, zinc plated, Cr(VI)-free	X	DPB1X
Stainless Steel 1.4571	71X	DPB14571X

Tube clamps series B – Complete range

Order codes for clamp halves:

Material	Interior surface	Order code
Polypropylene	grooved	RBP
	smooth	RBPG
Polyamide	grooved	RBN
	smooth	RBNG
Rubber	smooth	RBVG¹⁾

(Please exchange as required standard abbreviation RBP in column for "Order code")

For flame- or corrosion retardant materials, please refer to page T5.

The steel parts of kits 1, 16 and 3 have the following surfaces:

Screws, bushes, cover plates = Cr(VI)-free galvanized

Welding plate = phosphated

Other compositions available on request.

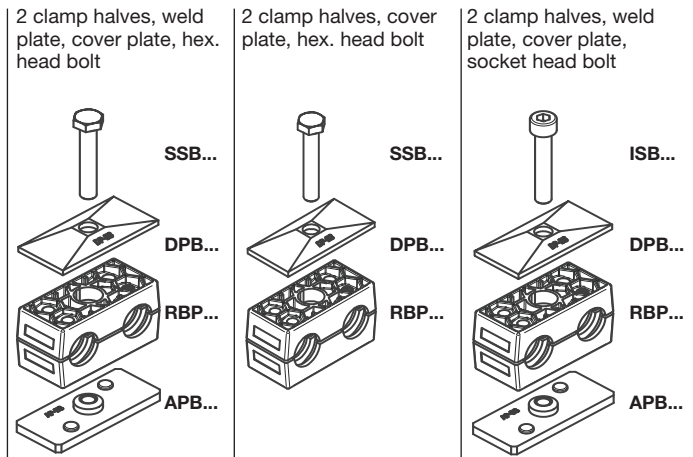

clamp size	Tube O.D. mm	Tube NB	Tube O.D.	Order code	Order code	Order code
1	6.0	G 1/8	1/4 5/16 3/8	RBP1-106	RBP16-106	RBP3-106
	6.4			RBP1-106.4	RBP16-106.4	RBP3-106.4
	8.0			RBP1-108	RBP16-108	RBP3-108
	9.5			RBP1-109.5	RBP16-109.5	RBP3-109.5
	10.0			RBP1-110	RBP16-110	RBP3-110
2	12.0	G 3/8	1/2 5/8	RBP1-112	RBP16-112	RBP3-112
	12.7			RBP1-212.7	RBP16-212.7	RBP3-212.7
	13.5			RBP1-213.5	RBP16-213.5	RBP3-213.5
	14.0			RBP1-214	RBP16-214	RBP3-214
	15.0			RBP1-215	RBP16-215	RBP3-215
3	16.0	G 1/2	3/4 1	RBP1-216	RBP16-216	RBP3-216
	17.2			RBP1-217.2	RBP16-217.2	RBP3-217.2
	18.0			RBP1-218	RBP16-218	RBP3-218
	19.0			RBP1-319	RBP16-319	RBP3-319
	20.0			RBP1-320	RBP16-320	RBP3-320
4	21.3	G 3/4	1	RBP1-321.3	RBP16-321.3	RBP3-321.3
	22.0			RBP1-322	RBP16-322	RBP3-322
	25.0			RBP1-325	RBP16-325	RBP3-325
	25.4			RBP1-325.4	RBP16-325.4	RBP3-325.4
	26.9			RBP1-426.9	RBP16-426.9	RBP3-426.9
5	28.0	G 1	1 1/4 1 1/2	RBP1-428	RBP16-428	RBP3-428
	30.0			RBP1-430	RBP16-430	RBP3-430
	32.0			RBP1-532	RBP16-532	RBP3-532
	33.7			RBP1-533.7	RBP16-533.7	RBP3-533.7
	35.0			RBP1-535	RBP16-535	RBP3-535
5	38.0	G 1 1/4	1 1/2	RBP1-538	RBP16-538	RBP3-538
	40.0			RBP1-540	RBP16-540	RBP3-540
	42.0			RBP1-542	RBP16-542	RBP3-542

Delivery in unassembled individual components.

¹⁾ When assembling solid rubber clamps, covering plates, hexagon screws and locking washers must be used.

Tube clamps

Tube clamps series B – Complete range

Order codes for clamp halves:

Material	Interior surface	Order code
Polypropylene	grooved	RBP
	smooth	RBPG
Polyamide	grooved	RBN
	smooth	RBNG
Rubber	smooth	RBVG ¹⁾

(Please exchange as required standard abbreviation RBP in column for "Order code")

For flame- or corrosion retardant materials, please refer to page T5.

The steel parts of kits 4, 5 and 8 have the following surfaces:

Screws, bushes, cover plates = Cr(VI)-free galvanized

Welding plate = phosphated

Other compositions available on request.

2 clamp halves,
rail nut, cover plate,
hex. head bolt

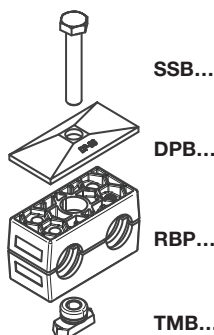

2 clamp halves,
rail nut, cover plate,
socket head bolt

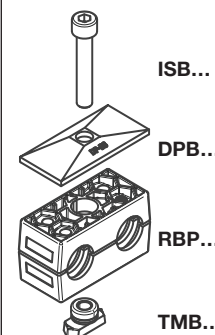

2 clamp halves,
locking plate,
stacking bolt

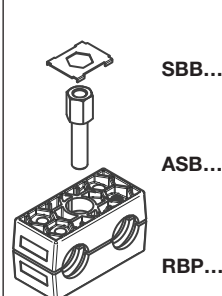

clamp size	Tube O.D. mm	Tube NB	Tube O.D.	Order code	Order code	Order code		
1	6.0	G 1/8	1/4	RBP4-106	RBP5-106	RBP8-106		
	6.4			RBP4-106.4	RBP5-106.4	RBP8-106.4		
	8.0			RBP4-108	RBP5-108	RBP8-108		
	9.5			RBP4-109.5	RBP5-109.5	RBP8-109.5		
	10.0			RBP4-110	RBP5-110	RBP8-110		
	12.0			RBP4-112	RBP5-112	RBP8-112		
2	12.7	G 1/4	1/2	RBP4-212.7	RBP5-212.7	RBP8-212.7		
	13.5			RBP4-213.5	RBP5-213.5	RBP8-213.5		
	14.0			RBP4-214	RBP5-214	RBP8-214		
	15.0			RBP4-215	RBP5-215	RBP8-215		
	16.0			G 3/8	5/8	RBP4-216	RBP5-216	RBP8-216
	17.2					RBP4-217.2	RBP5-217.2	RBP8-217.2
18.0	RBP4-218	RBP5-218	RBP8-218					
3	19.0	G 1/2	3/4	RBP4-319	RBP5-319	RBP8-319		
	20.0			RBP4-320	RBP5-320	RBP8-320		
	21.3			RBP4-321.3	RBP5-321.3	RBP8-321.3		
	22.0			RBP4-322	RBP5-322	RBP8-322		
	25.0			1	1	RBP4-325	RBP5-325	RBP8-325
	25.4					RBP4-325.4	RBP5-325.4	RBP8-325.4
4	26.9	G 3/4		RBP4-426.9	RBP5-426.9	RBP8-426.9		
	28.0			RBP4-428	RBP5-428	RBP8-428		
	30.0			RBP4-430	RBP5-430	RBP8-430		
5	32.0	G 1	1 1/4	RBP4-532	RBP5-532	RBP8-532		
	33.7			RBP4-533.7	RBP5-533.7	RBP8-533.7		
	35.0			RBP4-535	RBP5-535	RBP8-535		
	38.0			1 1/2	RBP4-538	RBP5-538	RBP8-538	
	40.0				RBP4-540	RBP5-540	RBP8-540	
	42.0				RBP4-542	RBP5-542	RBP8-542	

Delivery in unassembled individual components.

1) When assembling solid rubber clamps, covering plates, hexagon screws and locking washers must be used.

Tube clamps series C (Heavy series) – Components

DIN 3015, part 2

Order codes for clamp halves:

Material	Interior surface	Order code
Polypropylene	grooved	RCP
	smooth	RCPG ¹⁾
Polyamide	grooved	RCN
	smooth	RCNG ¹⁾
Rubber	grooved	RCVR ¹⁾²⁾
	smooth	RCVG ¹⁾²⁾
Aluminium	grooved	RCA

(Please exchange as required standard abbreviation RCP in column for “clamp halves”)

For flame- or corrosion retardant materials, please refer to page T5.

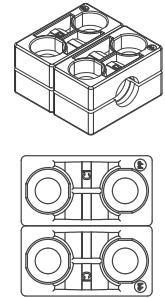
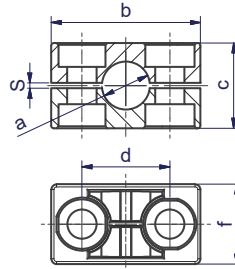
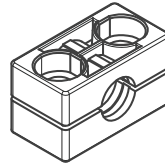

Please order 2x the single clamp (e.g. 2x RCP...)

clamp size	Tube O.D. mm a	Tube NB	Tube O.D.	1 part 2 clamp halves					dimensions: f	
				RCP... Order code	dimensions: b c d s f					
1	6.0	G 1/8	5/16	RCP106X	56	32	33	2	30	60
	8.0		3/8	RCP108X						
	9.5		RCP109.5X							
	10.0		RCP110X							
	12.0		RCP112X							
	12.7	1/2	RCP112.7X							
	13.5	G 1/4	RCP113.5X							
	14.0	RCP114X								
	15.0	RCP115X								
	16.0	RCP116X								
17.2	G 3/8	5/8	RCP117.2X							
18.0		RCP118X								
2	19.0	G 1/2	3/4	RCP219X	71	48	45	2	30	60
	20.0		RCP220X							
	21.3		RCP221.3X							
	22.0		RCP222X							
	23.0		RCP223X							
	25.0	1	RCP225X							
	25.4	G 3/4	RCP225.4X							
	26.9		RCP226.9X							
	28.0		RCP228X							
	30.0		RCP230X							
3	30.0		G 1	1 1/4	RCP330X	86	60	60	2	30
	32.0	RCP332X								
	33.7	RCP333.7X								
	35.0	RCP335X								
	38.0	1 1/2	RCP338X							
	40.0	G 1 1/4	RCP340X							
	42.0		RCP342X							
4	38.0		G 1 1/4	1 1/2	RCP438X	117	90	90	3	45
	40.0	RCP440X								
	42.0	RCP442X								
	45.0	RCP445X								
	48.3	G 1 1/2	RCP448.3X							
	50.0		RCP450X							
	51.0		2	RCP451X						
	52.0		RCP452X							
	55.0	G 2	2 1/4	RCP455X						
	57.0		RCP457X							
	60.3		2 1/2	RCP460.3X						
	63.0		RCP463X							
65.0	RCP465X									
70.0	2 3/4	RCP470X								

Continuation see next page ...

Tube clamps

Tube clamps series C (Heavy series) – Components (Continued)

DIN 3015, part 2

Order codes for clamp halves:

Material	Interior surface	Order code
Polypropylene	grooved	RCP
	smooth	RCPG ¹⁾
Polyamide	grooved	RCN
	smooth	RCNG ¹⁾
Rubber	grooved	RCVR ¹⁾²⁾
	smooth	RCVG ¹⁾²⁾
Aluminium	grooved	RCA

(Please exchange as required standard abbreviation RCP in column for “clamp halves”)

For flame- or corrosion retardant materials, please refer to page T5.

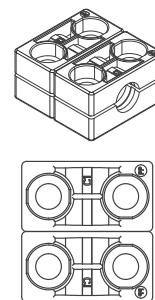
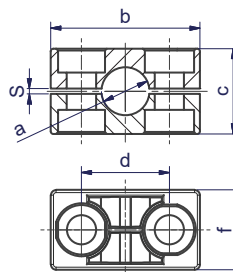
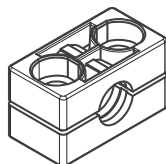

Please order 2x the single clamp (e.g. 2x RCP...)

clamp size	Tube O.D. mm a	Tube NB	Tube O.D.	1 part 2 clamp halves dimensions:					dimensions: f	
				RCP... Order code	b	c	d	s		f
5	65.0	G 2 1/2	2 3/4	RCP565X	154	120	122	5	60	120
	70.0			RCP570X						
	73.0			RCP573X						
	75.0			RCP575X						
	76.1			RCP576.1X						
	80.0	RCP580X								
	82.5	RCP582.5X								
	85.0	RCP585X								
	88.0	RCP588X								
	88.9	RCP588.9X								
90.0	RCP590X	G 3	3 1/2							
6	90.0	G 3 1/2	4	RCP690X	206	168	168	6	80	160
	97.0			RCP697X						
	100.0			RCP6100X						
	101.6			RCP6101.6X						
	108.0			RCP6108X						
	114.3	RCP6114.3X								
	115.0	RCP6115X								
	120.0	RCP6120X								
	127.0	RCP6127X	G 4	4 1/2						
	7	127.0	G 5	5						
130.0		RCP7130X								
133.0		RCP7133X								
140.0		RCP7140X								
150.0		RCP7150X								
152.4		RCP7152.4X								
159.0		RCP7159X								
165.1		RCP7165.1X								
168.3		RCP7168.3X	G 5 1/2	6						
8		168.3	G 6	6 5/8	RCP8168.3X	320	270	265	6	120
	177.8	RCP8177.8X								
	190.0	RCP8190X								
	193.7	RCP8193.7X								
	203.0	RCP8203X								
	219.1	RCP8219.1X								
	220.0	RCP8220X								
	219.1	RCP9219.1X		G 8	8 5/8					
9	244.5	G 10	10 3/4	RCP9244.5X	470	410	395	20	162	324
	273.0		RCP9273X							
	323.9		RCP9323.9X							
	355.6		RCP10355.6X							
10	406.4	G 16		RCP10406.4X	630	530	534	20	182	364

1) Only sizes 1–8

2) When assembling solid rubber clamps, covering plates, hexagon screws and locking washers must be used.

Tube clamps series C (Heavy series) – Components

DIN 3015, part 2

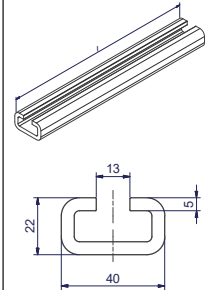
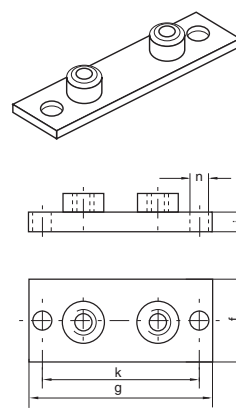
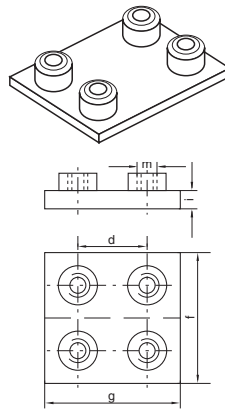
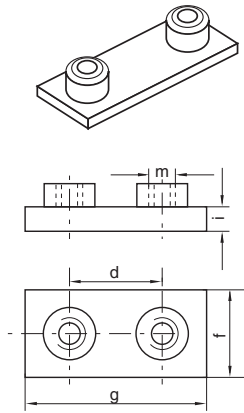

clamp size	weld plate					double weld plate					weld/screw plate					mounting rail				
	AP C... Order code	dimensions:					APD C... Order code	dimensions:					APL C... Order code	dimensions:					TS C... Order code	length: l
		d	f	g	i	m		d	f	g	i	m		g	f	i	k	n		
1	APC1...*	33	30	73	8	M10	APDC1...*	33	60	73	8	M10	APLC1...*	113	30	8	85	11	TSC1X TSC1VERZX TSC14571X	1 m
2	APC2...*	45	30	84	8	M10	APDC2...*	45	60	84	8	M10	APLC2...*	125	30	8	97	11		
3	APC3...*	60	30	100	8	M10	APDC3...*	60	60	100	8	M10	APLC3...*	140	30	8	112	11		
4	APC4...*	90	45	140	10	M12	APDC4...*	90	90	140	10	M12	APLC4...*	190	45	10	160	14	TSC2X TSC2VERZX TSC24571X	2m
5	APC5...*	122	60	180	10	M16	APDC5...*	122	120	180	10	M16	APLC5...*	240	60	10	205	18		
6	APC6...*	168	80	225	15	M20	APDC6...*	168	160	225	15	M20	APLC6...*	310	80	15	270	22		
7	APC7...*	205	90	270	15	M24	APDC7...*	205	180	270	15	M24	APLC7...*	370	90	15	320	26		
8	APC8...*	265	120	340	25	M30	APDC8...*	265	240	340	25	M30	APLC8...*	450	120	25	390	33		
9	APC9...*	395	160	520	30	M30	APDC9...*	395	330	520	30	M30								
10	APC10...*	534	180	680	30	M30	APDC10...*	534	364	680	30	M30								

Complete programme range please refer to page T34.

*Please add the suffix below according to the surface/material required.

Order code suffixes		
Surface/material	Suffix	Example
Steel, phosphated	X	APC1X
Steel, zinc plated, Cr(VI)-free	VZX	APC1VZX
Stainless Steel 1.4571	4571X	APC14571X

Tube clamps series C (Heavy series) – Components

DIN 3015, part 2

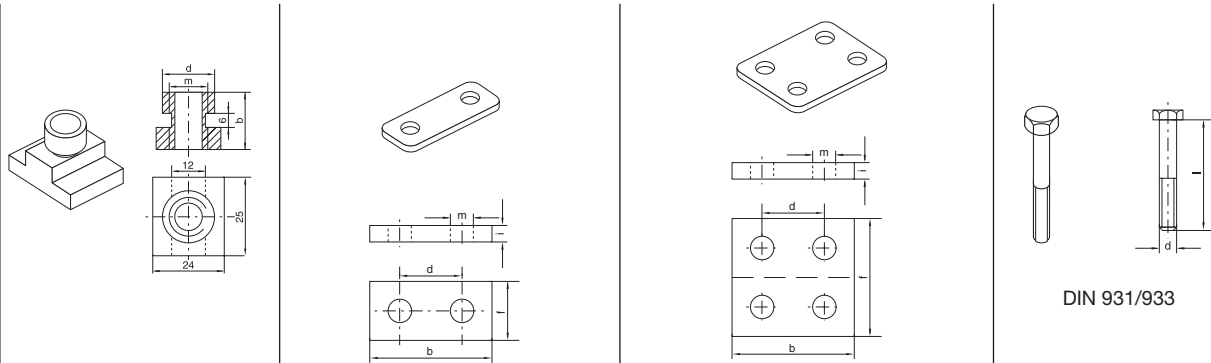

clamp size	rail nut		cover plate					double cover plate					hexagon head			
	TM C... Order code	dimensions: b d m	DP C... Order code	dimensions: b d f i m					DPD C... Order code	dimensions: b d f i m					SS C... Order code	dimensions: d x L
1	TMC1VZX TMC14571X	20 12.0 M10	DPC1...*	55	33	30	8	11	DPDC1...*	55	33	60	8	11	SSC1...*	M 10×40
2			DPC2...*	70	45	30	8	11	DPDC2...*	70	45	60	8	11	SSC2...*	M 10×60
3			DPC3...*	85	60	30	8	11	DPDC3...*	85	60	60	8	11	SSC3...*	M 10×70
4	TMC4VZX TMC44571X	23 12.5 M12	DPC4...*	115	90	45	10	14	DPDC4...*	115	90	90	10	14	SSC4...*	M 12×100
5	-	-	DPC5...*	152	122	60	10	18	DPDC5...*	152	122	120	10	18	SSC5...*	M 16×130
6			DPC6...*	205	168	80	15	22	DPDC6...*	205	168	160	15	24	SSC6...*	M 20×190
7			DPC7...*	251	205	90	15	28	DPDC7...*	250	205	180	15	28	SSC7...*	M 24×220
8			DPC8...*	320	265	120	25	35	DPDC8...*	322	265	240	25	35	SSC8...*	M 30×300
9			DPC9...*	470	395	160	30	35	DPDC9...*	466	395	330	30	35	SSC9...*	M 30×450
10			DPC10...*	630	534	180	30	35	DPDC10...*	630	534	360	30	35	SSC10...*	M 30×560

*Please add the suffix below according to the surface/material required.

Order code suffixes		
Surface/material	Suffix	Example
Steel, phosphated	X	DPC1X
Steel, zinc plated, Cr(VI)-free	VZX	DPC1VZX
Stainless Steel 1.4571	4571X	DPC14571X

Tube clamps series C (Heavy series) – Components

DIN 3015, part 2

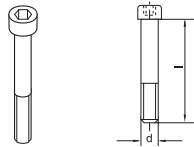

ISO 4762

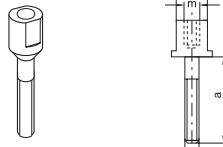

DIN 938

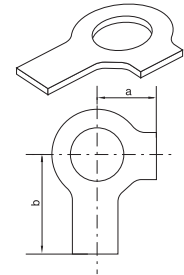
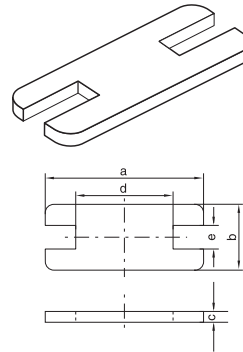

clamp size	socket head		stacking			locking plate ¹⁾					locking washer ²⁾				
	IS C... Order code	dimensions: d × L	AS C... Order code	dimensions: a m SW			SP C... Order code	dimensions: a b c d e					US C... Order code	dimensions: a b	
1	ISC1...*	M 10×45	ASC1...*	25	M10	15	SPC1...*	55	30	8	14	15.5	USC1X ³⁾ USC14571X	13	22
2	ISC2...*	M 10×60	ASC2...*	40	M10	15	SPC2...*	70	30	8	26	15.5			
3	ISC3...*	M 10×70	ASC3...*	50	M10	15	SPC3...*	85	30	8	41	15.5			
4	ISC4...*	M 12×100	ASC4...*	80	M12	17	SPC4...*	115	45	10	69	17.5	USC4X ³⁾ USC44571X	15	28
5	ISC5...*	M 16×130	ASC5...*	110	M16	21	SPC5...*	152	60	10	97	21.5	USC5X ³⁾ USC54571X	18	32
6	ISC6...*	M 20×190	ASC6...*	155	M20	27	SPC6...*	205	80	15	137	27.5	USC6X ³⁾ USC64571X	21	36
7	ISC7...*	M 24×220	ASC7...*	180	M24	30	SPC7...*	250	90	15	169	30.5	USC7X ³⁾ USC74571X	25	42
8	ISC8...*	M 30×300	ASC8...*	250	M30	36	SPC8...*	320	120	25	219	36.5	USC8X ³⁾ USC84571X	32	52
9	ISC9...*	M 30×450													
10	ISC10...*	M 30×560													

¹⁾ The use of stacking screws necessitates the use of locking plates in the construction assembly!

²⁾ When assembling solid rubber clamps, covering plates, hexagon screws and locking washers must be used.

³⁾ Material = Steel, zinc plated, Cr(VI)-free

*Please add the suffix below according to the surface/material required.

Order code suffixes		
Surface/material	Suffix	Example
Steel, phosphated	X	ISC1X
Steel, zinc plated, Cr(VI)-free	VZX	ISC1VZX
Stainless Steel 1.4571	4571X	ISC14571X

Tube clamps series C – Complete range

Order codes for clamp halves:

Material	Interior surface	Order code
Polypropylene	grooved	RCP
	smooth	RCPG ¹⁾
Polyamide	grooved	RCN
	smooth	RCNG ¹⁾
Rubber	grooved	RCVR ¹⁾²⁾
	smooth	RCVG ¹⁾²⁾
Aluminium	grooved	RCA

(Please exchange as required standard abbreviation RCP in column for "Order code")

For flame- or corrosion retardant materials, please refer to page T5.

The steel parts of kits 1 and 2 are phosphated.

Other compositions available on request.

2 clamp halves, weld plate, cover plate, hex. head bolt

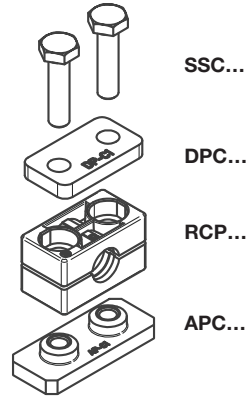

2 clamp halves, weld plate, cover plate, socket head bolt

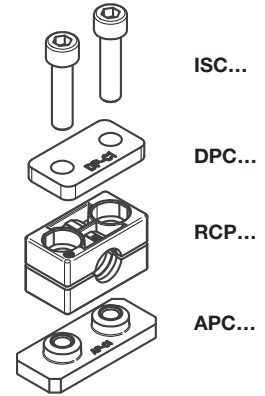

clamp size	Tube O.D. mm	Tube NB	Tube O.D.	Order code	Order code
1	6.0	G 1/8	5/16	RCP1-106	RCP2-106
	8.0		3/8	RCP1-108	RCP2-108
	9.5		RCP1-109.5	RCP2-109.5	
	10.0		RCP1-110	RCP2-110	
	12.0	G 1/4	1/2	RCP1-112	RCP2-112
	12.7		RCP1-112.7	RCP2-112.7	
	13.5		RCP1-113.5	RCP2-113.5	
	14.0		RCP1-114	RCP2-114	
	15.0		5/8	RCP1-115	RCP2-115
	16.0		RCP1-116	RCP2-116	
17.2	G 3/8	RCP1-117.2	RCP2-117.2		
18.0		RCP1-118	RCP2-118		
2	19.0	G 1/2	3/4	RCP1-219	RCP2-219
	20.0		RCP1-220	RCP2-220	
	21.3		RCP1-221.3	RCP2-221.3	
	22.0		RCP1-222	RCP2-222	
	23.0		RCP1-223	RCP2-223	
	25.0		RCP1-225	RCP2-225	
	25.4	G 3/4	1	RCP1-225.4	RCP2-225.4
	26.9		RCP1-226.9	RCP2-226.9	
	28.0		RCP1-228	RCP2-228	
	30.0		RCP1-230	RCP2-230	
3	30.0	G 1	1 1/4	RCP1-330	RCP2-330
	32.0		RCP1-332	RCP2-332	
	33.7		RCP1-333.7	RCP2-333.7	
	35.0		RCP1-335	RCP2-335	
	38.0	G 1 1/4	1 1/2	RCP1-338	RCP2-338
	40.0		RCP1-340	RCP2-340	
42.0	RCP1-342	RCP2-342			
4	38.0	G 1 1/4	1 1/2	RCP1-438	RCP2-438
	40.0		RCP1-440	RCP2-440	
	42.0		RCP1-442	RCP2-442	
	45.0	G 1 1/2	2	RCP1-445	RCP2-445
	48.3			RCP1-448.3	RCP2-448.3
	50.0			RCP1-450	RCP2-450
	51.0	G 2	2	RCP1-451	RCP2-451
	52.0			RCP1-452	RCP2-452
	55.0			RCP1-455	RCP2-455
	57.0			RCP1-457	RCP2-457
	60.3			2 1/4	RCP1-460.3
	63.0	2 1/2	2 1/2	RCP1-463	RCP2-463
	65.0			RCP1-465	RCP2-465
70.0	RCP1-470			RCP2-470	

Continuation see next page ...

Tube clamps series C – Complete range (Continued)

Order codes for clamp halves:

Material	Interior surface	Order code
Polypropylene	grooved	RCP
	smooth	RCPG ¹⁾
Polyamide	grooved	RCN
	smooth	RCNG ¹⁾
Rubber	grooved	RCVR ¹⁾²⁾
	smooth	RCVG ¹⁾²⁾
Aluminium	grooved	RCA

(Please exchange as required standard abbreviation RCP in column for "Order code")

For flame- or corrosion retardant materials, please refer to page T5.

The steel parts of kits 1 and 2 are phosphated.

Other compositions available on request.

2 clamp halves, weld plate,
cover plate, hex. head bolt

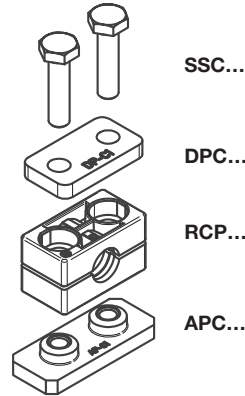

2 clamp halves, weld plate,
cover plate, socket head bolt

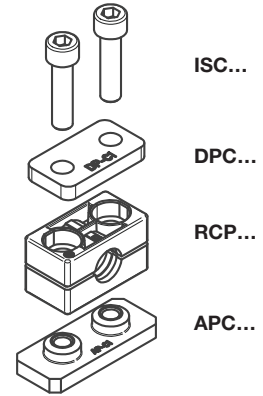

clamp size	Tube O.D. mm	Tube NB	Tube O.D.	Order code	Order code
5	65.0	G 2 1/2	3	RCP1-565	RCP2-565
	70.0			RCP1-570	RCP2-570
	73.0			RCP1-573	RCP2-573
	75.0			RCP1-575	RCP2-575
	76.1			RCP1-576.1	RCP2-576.1
	80.0			RCP1-580	RCP2-580
	82.5			RCP1-582.5	RCP2-582.5
	85.0			RCP1-585	RCP2-585
	88.0			RCP1-588	RCP2-588
	88.9			RCP1-588.9	RCP2-588.9
90.0	RCP1-590	RCP2-590			
6	90.0	G 3 1/2	4	RCP1-690	RCP2-690
	97.0			RCP1-697	RCP2-697
	100.0			RCP1-6100	RCP2-6100
	101.6			RCP1-6101.6	RCP2-6101.6
	108.0			RCP1-6108	RCP2-6108
	114.3			RCP1-6114.3	RCP2-6114.3
	115.0			RCP1-6115	RCP2-6115
	120.0			RCP1-6120	RCP2-6120
	127.0			RCP1-6127	RCP2-6127
	7			127.0	G 5
130.0		RCP1-7130	RCP2-7130		
133.0		RCP1-7133	RCP2-7133		
140.0		RCP1-7140	RCP2-7140		
150.0		RCP1-7150	RCP2-7150		
152.4		RCP1-7152.4	RCP2-7152.4		
159.0		RCP1-7159	RCP2-7159		
165.1		RCP1-7165.1	RCP2-7165.1		
168.3		RCP1-7168.3	RCP2-7168.3		
8		168.3	G 5 1/2	6	
	177.8	RCP1-8177.8			RCP2-8177.8
	190.0	RCP1-8190			RCP2-8190
	193.7	RCP1-8193.7			RCP2-8193.7
	203.0	RCP1-8203			RCP2-8203
	219.1	RCP1-8219.1			RCP2-8219.1
	220.0	RCP1-8220			RCP2-8220
	9	219.1			G 6 1/4
244.5		RCP1-9244.5	RCP2-9244.5		
273.0		RCP1-9273	RCP2-9273		
323.9		RCP1-9323.9	RCP2-9323.9		
10	355.6	G 7 1/2	8	RCP1-10355.6	RCP2-10355.6
	406.4			RCP1-10406.4	RCP2-10406.4

Delivery in unassembled individual components.

¹⁾ Only sizes 1–8

²⁾ When assembling solid rubber clamps, covering plates, hexagon screws and locking washers must be used.

Tube clamps series C – Complete range

Order codes for clamp halves:

Material	Interior surface	Order code
Polypropylene	grooved	RCP
	smooth	RCPG ¹⁾
Polyamide	grooved	RCN
	smooth	RCNG ¹⁾
Rubber	grooved	RCVR ¹⁾²⁾
	smooth	RCVG ¹⁾²⁾
Aluminium	grooved	RCA

(Please exchange as required standard abbreviation RCP in column for "Order code")

For flame- or corrosion retardant materials, please refer to page T5.

The steel parts of kits 3, 4 and 5 have the following surfaces:

Bolts, cover plate, locking plate = phosphated

Rail nuts = Cr(VI)-free galvanized

Other compositions available on request.

2 clamp halves,
rail nuts, cover plate,
hex. head bolts

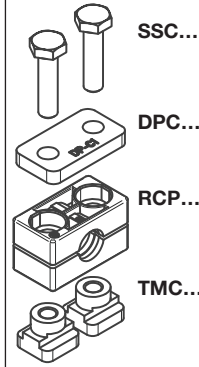

2 clamp halves,
rail nuts, cover plate,
socket head bolts

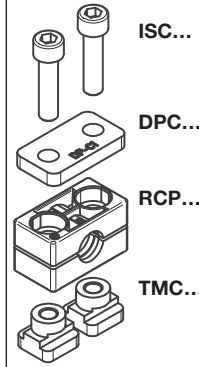

2 clamp halves, lock-
ing plate, stacking
bolts

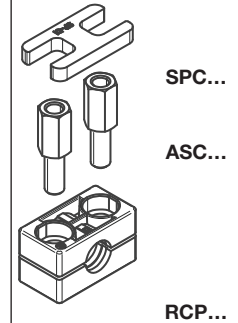

clamp size	Tube O.D. mm	Tube NB	Tube O.D.	Order code	Order code	Order code	
1	6.0	G 1/8	5/16	RCP3-106	RCP4-106	RCP5-106	
	8.0			RCP3-108	RCP4-108	RCP5-108	
	9.5		1/2	RCP3-109.5	RCP4-109.5	RCP5-109.5	
	10.0			RCP3-110	RCP4-110	RCP5-110	
	12.0	G 1/4	5/8	RCP3-112	RCP4-112	RCP5-112	
	12.7			RCP3-112.7	RCP4-112.7	RCP5-112.7	
	13.5			RCP3-113.5	RCP4-113.5	RCP5-113.5	
	14.0			RCP3-114	RCP4-114	RCP5-114	
	15.0			RCP3-115	RCP4-115	RCP5-115	
	16.0			G 3/8	RCP3-116	RCP4-116	RCP5-116
17.2	RCP3-117.2	RCP4-117.2	RCP5-117.2				
18.0	RCP3-118	RCP4-118	RCP5-118				
2	19.0	G 1/2	3/4		RCP3-219	RCP4-219	RCP5-219
	20.0			RCP3-220	RCP4-220	RCP5-220	
	21.3			1	RCP3-221.3	RCP4-221.3	RCP5-221.3
	22.0				RCP3-222	RCP4-222	RCP5-222
	23.0	G 3/4	1	RCP3-223	RCP4-223	RCP5-223	
	25.0			RCP3-225	RCP4-225	RCP5-225	
	25.4			RCP3-225.4	RCP4-225.4	RCP5-225.4	
	26.9			RCP3-226.9	RCP4-226.9	RCP5-226.9	
	28.0			RCP3-228	RCP4-228	RCP5-228	
	30.0			RCP3-230	RCP4-230	RCP5-230	
3	30.0	G 1	1 1/4	RCP3-330	RCP4-330	RCP5-330	
	32.0			RCP3-332	RCP4-332	RCP5-332	
	33.7			1 1/2	RCP3-333.7	RCP4-333.7	RCP5-333.7
	35.0				RCP3-335	RCP4-335	RCP5-335
	38.0	G 1 1/4	1 1/2	RCP3-338	RCP4-338	RCP5-338	
	40.0			RCP3-340	RCP4-340	RCP5-340	
	42.0			RCP3-342	RCP4-342	RCP5-342	
4	38.0	G 1 1/4	1 1/2	RCP3-438	RCP4-438	RCP5-438	
	40.0			RCP3-440	RCP4-440	RCP5-440	
	42.0			RCP3-442	RCP4-442	RCP5-442	
	45.0	G 1 1/2	2	RCP3-445	RCP4-445	RCP5-445	
	48.3			RCP3-448.3	RCP4-448.3	RCP5-448.3	
	50.0	G 2	2	RCP3-450	RCP4-450	RCP5-450	
	51.0			RCP3-451	RCP4-451	RCP5-451	
	52.0			RCP3-452	RCP4-452	RCP5-452	
	55.0			RCP3-455	RCP4-455	RCP5-455	
	57.0	2 1/4	2 1/4	RCP3-457	RCP4-457	RCP5-457	
	60.3			RCP3-460.3	RCP4-460.3	RCP5-460.3	
	63.0			RCP3-463	RCP4-463	RCP5-463	
	65.0			RCP3-465	RCP4-465	RCP5-465	
70.0	2 1/2	2 1/2	RCP3-470	RCP4-470	RCP5-470		

Continuation see next page ...

Tube clamps series C – Complete range (Continued)

Order codes for clamp halves:

Material	Interior surface	Order code
Polypropylene	grooved	RCP
	smooth	RCPG ¹⁾
Polyamide	grooved	RCN
	smooth	RCNG ¹⁾
Rubber	grooved	RCVR ¹⁾²⁾
	smooth	RCVG ¹⁾²⁾
Aluminium	grooved	RCA

(Please exchange as required standard abbreviation RCP in column for "Order code")

For flame- or corrosion retardant materials, please refer to page T5.

The steel parts of kits 5 are phosphated.

Other compositions available on request.

2 clamp halves, locking plate, stacking bolts

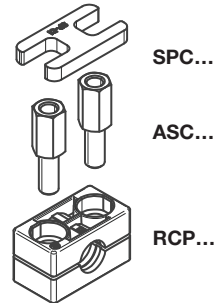

clamp size	Tube O.D. mm	Tube NB	Tube O.D.	Order code			
5	65.0	G 2 1/2	3	RCP5-565			
	70.0			RCP5-570			
	73.0			RCP5-573			
	75.0			RCP5-575			
	76.1			RCP5-576.1			
	80.0			RCP5-580			
	82.5			RCP5-582.5			
	85.0			RCP5-585			
	88.0			RCP5-588			
	88.9			RCP5-588.9			
6	90.0	G 3	3 1/2	RCP5-590			
	97.0			RCP5-690			
	100.0			RCP5-697			
	101.6			RCP5-6100			
	108.0			RCP5-6101.6			
	114.3			RCP5-6108			
	115.0			RCP5-6114.3			
	120.0			RCP5-6115			
	127.0			RCP5-6120			
	7			127.0	G 3 1/2	4	RCP5-6127
130.0		RCP5-690					
133.0		RCP5-697					
140.0		RCP5-6100					
150.0		RCP5-6101.6					
152.4		RCP5-6108					
159.0		RCP5-6114.3					
165.1		RCP5-6115					
168.3		RCP5-6120					
8		168.3	G 4	4 1/2			RCP5-7127
	177.8	RCP5-7130					
	190.0	RCP5-7133					
	193.7	RCP5-7133					
	203.0	RCP5-7140					
	219.1	RCP5-7140					
	220.0	RCP5-7150					
	8	168.3			G 5	5 1/4	RCP5-7150
		177.8					RCP5-7150
		190.0					RCP5-7150
193.7		RCP5-7150					
203.0		RCP5-7150					
219.1		RCP5-7150					
220.0		RCP5-7150					
8		168.3	G 5 1/2	6			RCP5-7152.4
		177.8					RCP5-7152.4
		190.0					RCP5-7152.4
	193.7	RCP5-7152.4					
	203.0	RCP5-7152.4					
	219.1	RCP5-7152.4					
	220.0	RCP5-7152.4					
	8	168.3			G 6	6 1/4	RCP5-7159
		177.8					RCP5-7159
		190.0					RCP5-7159
193.7		RCP5-7159					
203.0		RCP5-7159					
219.1		RCP5-7159					
220.0		RCP5-7159					
8		168.3	G 6	6 1/2			RCP5-7165.1
		177.8					RCP5-7165.1
		190.0					RCP5-7165.1
	193.7	RCP5-7165.1					
	203.0	RCP5-7165.1					
	219.1	RCP5-7165.1					
	220.0	RCP5-7165.1					
	8	168.3			G 8	6 5/8	RCP5-8168.3
		177.8					RCP5-8168.3
		190.0					RCP5-8168.3
193.7		RCP5-8168.3					
203.0		RCP5-8168.3					
219.1		RCP5-8168.3					
220.0		RCP5-8168.3					
8		168.3	G 8	7			RCP5-8177.8
		177.8					RCP5-8177.8
		190.0					RCP5-8177.8
	193.7	RCP5-8177.8					
	203.0	RCP5-8177.8					
	219.1	RCP5-8177.8					
	220.0	RCP5-8177.8					
	8	168.3			G 8	7 5/8	RCP5-8190
		177.8					RCP5-8190
		190.0					RCP5-8190
193.7		RCP5-8190					
203.0		RCP5-8190					
219.1		RCP5-8190					
220.0		RCP5-8190					
8		168.3	G 8	8 5/8			RCP5-8193.7
		177.8					RCP5-8193.7
		190.0					RCP5-8193.7
	193.7	RCP5-8193.7					
	203.0	RCP5-8193.7					
	219.1	RCP5-8193.7					
	220.0	RCP5-8193.7					
	8	168.3			G 8	8 5/8	RCP5-8203
		177.8					RCP5-8203
		190.0					RCP5-8203
193.7		RCP5-8203					
203.0		RCP5-8203					
219.1		RCP5-8203					
220.0		RCP5-8203					
8		168.3	G 8	8 5/8			RCP5-8219.1
		177.8					RCP5-8219.1
		190.0					RCP5-8219.1
	193.7	RCP5-8219.1					
	203.0	RCP5-8219.1					
	219.1	RCP5-8219.1					
	220.0	RCP5-8219.1					
	8	168.3			G 8	8 5/8	RCP5-8220
		177.8					RCP5-8220
		190.0					RCP5-8220
193.7		RCP5-8220					
203.0		RCP5-8220					
219.1		RCP5-8220					
220.0		RCP5-8220					

Delivery in unassembled individual components.

¹⁾ Only sizes 1–8

²⁾ When assembling solid rubber clamps, covering plates, hexagon screws and locking washers must be used.

Tube clamps

Multiclamp series A

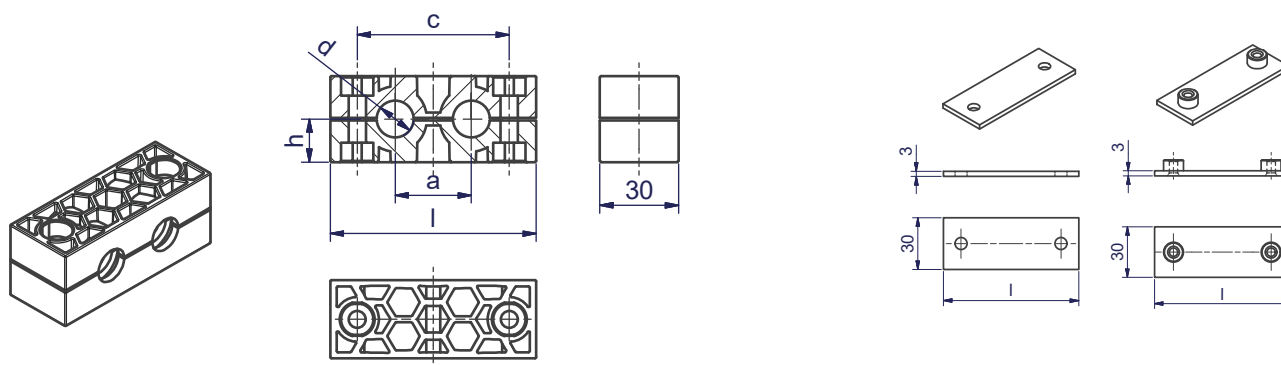

clamp size	Tube O.D. mm d	Number of tubes	Number of Fastening screws B	1 part 2 clamp halves RAPM Order code	2 clamp-halves RAPM-...				cover plate		weld plate	
					a	c	h	l	Order code	length:	Order code	length:
1	6.0	2	2	RAPM106B2X	20	40	13.5	60.5	DPM1B2...*	60.5	APM1B2...*	62.5
	6.4			RAPM106.4B2X								
	8.0			RAPM108B2X								
	9.5			RAPM109.5B2X								
	10.0			RAPM110B2X								
	12.0			RAPM112B2X								
2	10.0	2	2	RAPM210B2X	29	58	16.5	78.5	DPM2B2...*	78.5	APM2B2...*	80.5
	12.0			RAPM212B2X								
	12.7			RAPM212.7B2X								
	13.5			RAPM213.5B2X								
	14.0			RAPM214B2X								
	15.0			RAPM215B2X								
	16.0			RAPM216B2X								
	17.2			RAPM217.2B2X								
	18.0			RAPM218B2X								
3	15.0	2	2	RAPM315B2X	36	72	18.5	92.5	DPM3B2...*	92.5	APM3B2...*	94.5
	16.0			RAPM316B2X								
	17.2			RAPM317.2B2X								
	18.0			RAPM318B2X								
	19.0			RAPM319B2X								
	20.0			RAPM320B2X								
	21.3			RAPM321.3B2X								
	22.0			RAPM322B2X								
	23.0			RAPM323B2X								
	25.0			RAPM325B2X								
	25.4			RAPM325.4B2X								

Order codes for clamp halves:

Material	Interior surface	Order code
Polypropylene	grooved	RAPM
	smooth	RAPGM
Polyamide	grooved	RANM
	smooth	RANGM
Rubber	smooth	RAVGM¹⁾

(Please exchange as required standard abbreviation RAPM in column for "Order code")

For flame- or corrosion retardant materials, please refer to page T5.

Different diameter on request.

¹⁾ When assembling solid rubber clamps, covering plates, hexagon screws and locking washers must be used.

*Please add the suffix below according to the surface/material required.

Order code suffixes		
Surface/material	Suffix	Example
Steel, phosphated	X	DPM1B2X
Steel, zinc plated, Cr(VI)-free	VZX	DPM1B2VZX
Stainless Steel 1.4571	4571X	DPM1B24571X

Multiclamp series A

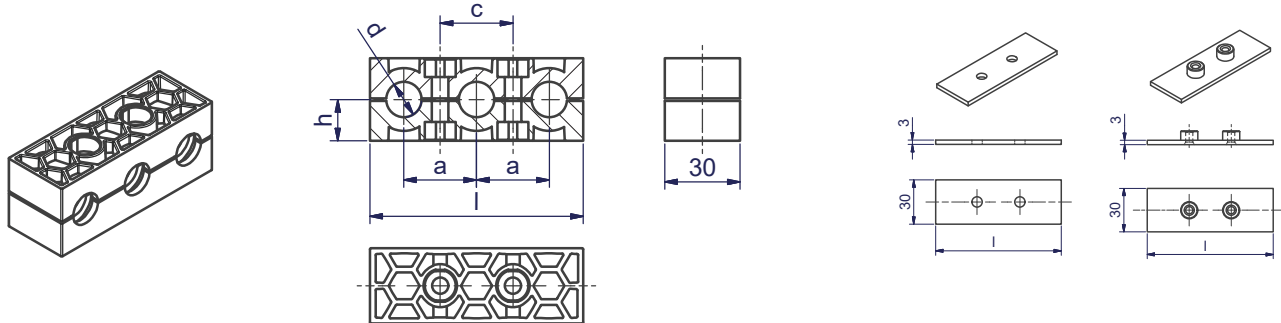

clamp size	Tube O.D. mm d	Number of tubes	Number of Fastening screws B	1 part 2 clamp halves RAPM Order code	2 clamp-halves RAPM-...				cover plate		weld plate	
					a	c	h	l	Order code	length:	Order code	length:
1	6.0	3	2	RAPM106B3X	20	20	13.5	56	DPM1B3...*	56	APM1B3...*	58
	6.4			RAPM106.4B3X								
	8.0			RAPM108B3X								
	9.5			RAPM109.5B3X								
	10.0			RAPM110B3X								
	12.0			RAPM112B3X								
2	10.0	3	2	RAPM210B3X	29	29	16.5	85	DPM2B3...*	85	APM2B3...*	87
	12.0			RAPM212B3X								
	12.7			RAPM212.7B3X								
	13.5			RAPM213.5B3X								
	14.0			RAPM214B3X								
	15.0			RAPM215B3X								
	16.0			RAPM216B3X								
	17.2			RAPM217.2B3X								
	18.0			RAPM218B3X								
3	15.0	3	2	RAPM315B3X	36	36	18.5	106	DPM3B3...*	106	APM3B3...*	108
	16.0			RAPM316B3X								
	17.2			RAPM317.2B3X								
	18.0			RAPM318B3X								
	19.0			RAPM319B3X								
	20.0			RAPM320B3X								
	21.3			RAPM321.3B3X								
	22.0			RAPM322B3X								
	23.0			RAPM323B3X								
	25.0			RAPM325B3X								
	25.4			RAPM325.4B3X								

Order codes for clamp halves:

Material	Interior surface	Order code
Polypropylene	grooved	RAPM
	smooth	RAPGM
Polyamide	grooved	RANM
	smooth	RANGM
Rubber	smooth	RAVGM¹⁾

(Please exchange as required standard abbreviation RAPM in column for "Order code")

For flame- or corrosion retardant materials, please refer to page T5.

Different diameter on request.

¹⁾ When assembling solid rubber clamps, covering plates, hexagon screws and locking washers must be used.

*Please add the suffix below according to the surface/material required.

Order code suffixes		
Surface/material	Suffix	Example
Steel, phosphated	X	DPM1B3X
Steel, zinc plated, Cr(VI)-free	VZX	DPM1B3VZX
Stainless Steel 1.4571	4571X	DPM1B34571X

Multiclamp series A

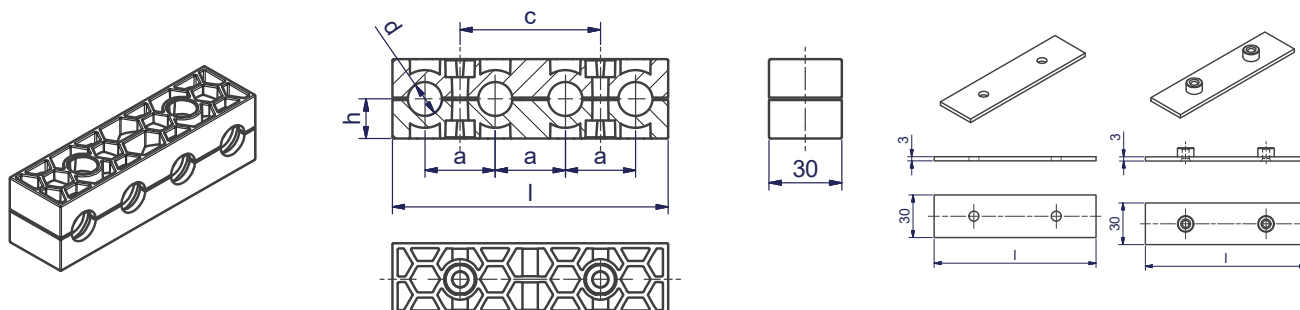

clamp size	Tube O.D. mm d	Number of tubes	Number of Fastening screws B	1 part 2 clamp halves RAPM Order code	2 clamp-halves RAPM-...				cover plate		weld plate	
					a	c	h	l	Order code	length:	Order code	length:
1	6.0	4	2	RAPM106B4X	20	40	13.5	76	DPM1B4...*	76	APM1B4...*	78
	6.4			RAPM106.4B4X								
	8.0			RAPM108B4X								
	9.5			RAPM109.5B4X								
	10.0			RAPM110B4X								
	12.0			RAPM112B4X								
2	10.0	4	2	RAPM210B4X	29	58	16.5	114	DPM2B4...*	114	APM2B4...*	116
	12.0			RAPM212B4X								
	12.7			RAPM212.7B4X								
	13.5			RAPM213.5B4X								
	14.0			RAPM214B4X								
	15.0			RAPM215B4X								
	16.0			RAPM216B4X								
	17.2			RAPM217.2B4X								
18.0	RAPM218B4X											
3	15.0	4	2	RAPM315B4X	36	72	18.5	142	DPM3B4...*	142	APM3B4...*	144
	16.0			RAPM316B4X								
	17.2			RAPM317.2B4X								
	18.0			RAPM318B4X								
	19.0			RAPM319B4X								
	20.0			RAPM320B4X								
	21.3			RAPM321.3B4X								
	22.0			RAPM322B4X								
	23.0			RAPM323B4X								
	25.0			RAPM325B4X								
	25.4			RAPM325.4B4X								

Order codes for clamp halves:

Material	Interior surface	Order code
Polypropylene	grooved	RAPM
	smooth	RAPGM
Polyamide	grooved	RANM
	smooth	RANGM
Rubber	smooth	RAVGM¹⁾

(Please exchange as required standard abbreviation RAPM in column for "Order code")

For flame- or corrosion retardant materials, please refer to page T5.

Different diameter on request.

¹⁾ When assembling solid rubber clamps, covering plates, hexagon screws and locking washers must be used.

*Please add the suffix below according to the surface/material required.

Order code suffixes		
Surface/material	Suffix	Example
Steel, phosphated	X	DPM1B4X
Steel, zinc plated, Cr(VI)-free	VZX	DPM1B4VZX
Stainless Steel 1.4571	4571X	DPM1B44571X

Multiclamp series A

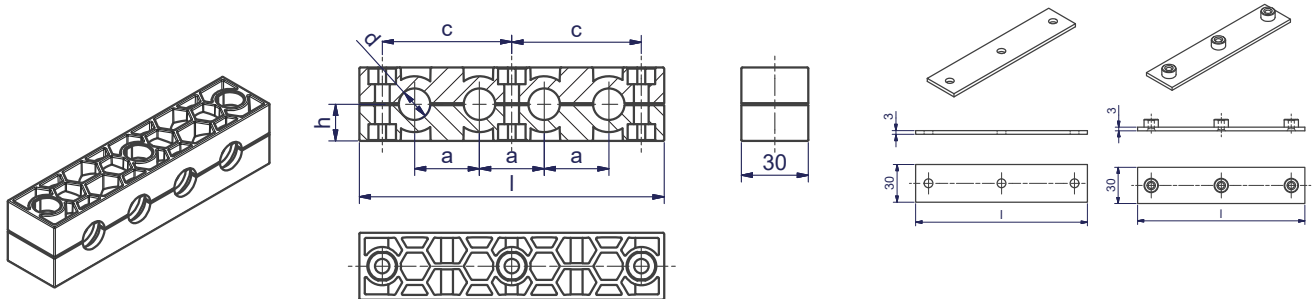

clamp size	Tube O.D. mm d	Number of tubes	Number of Fastening screws C	1 part 2 clamp halves RAPM Order code	2 clamp-halves RAPM-...				cover plate		weld plate	
					a	c	h	l	Order code	length:	Order code	length:
1	6.0	4	3	RAPM106C4X RAPM106.4C4X RAPM108C4X RAPM109.5C4X RAPM110C4X RAPM112C4X	20	40	13.5	100.5	DPM1C4...*	100.5	APM1C4...*	102.5
	6.4											
	8.0											
	9.5											
	10.0											
	12.0											
2	10.0	4	3	RAPM210C4X RAPM212C4X RAPM212.7C4X RAPM213.5C4X RAPM214C4X RAPM215C4X RAPM216C4X RAPM217.2C4X RAPM218C4X	29	58	16.5	136.5	DPM2C4...*	136.5	APM2C4...*	138.5
	12.0											
	12.7											
	13.5											
	14.0											
	15.0											
	16.0											
	17.2											
	18.0											
3	15.0	4	3	RAPM315C4X RAPM316C4X RAPM317.2C4X RAPM318C4X RAPM319C4X RAPM320C4X RAPM321.3C4X RAPM322C4X RAPM323C4X RAPM325C4X RAPM325.4C4X	36	72	18.5	164.5	DPM3C4...*	164.5	APM3C4...*	166.5
	16.0											
	17.2											
	18.0											
	19.0											
	20.0											
	21.3											
	22.0											
	23.0											
	25.0											
	25.4											

Order codes for clamp halves:

Material	Interior surface	Order code
Polypropylene	grooved	RAPM
	smooth	RAPGM
Polyamide	grooved	RANM
	smooth	RANGM
Rubber	smooth	RAVGM ¹⁾

(Please exchange as required standard abbreviation RAPM in column for "Order code")

For flame- or corrosion retardant materials, please refer to page T5.

Different diameter on request.

¹⁾ When assembling solid rubber clamps, covering plates, hexagon screws and locking washers must be used.

*Please add the suffix below according to the surface/material required.

Order code suffixes		
Surface/material	Suffix	Example
Steel, phosphated	X	DPM1C4X
Steel, zinc plated, Cr(VI)-free	VZX	DPM1C4VZX
Stainless Steel 1.4571	4571X	DPM1C44571X

Tube clamps

Multiclamp series A

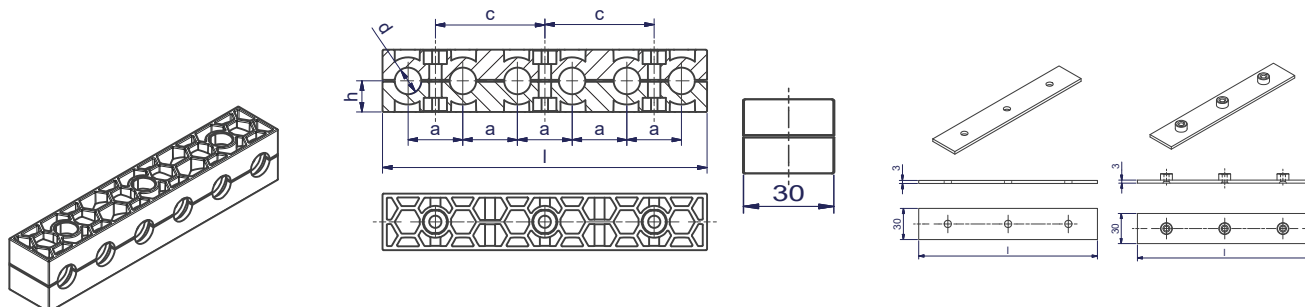

clamp size	Tube O.D. mm d	Number of tubes	Number of Fastening screws C	1 part 2 clamp halves RAPM Order code	2 clamp-halves RAPM-...				cover plate		weld plate	
					a	c	h	l	Order code	length:	Order code	length:
1	6.0	6	3	RAPM106C6X	20	40	13.5	116	DPM1C6...*	116	APM1C6...*	118
	6.4			RAPM106.4C6X								
	8.0			RAPM108C6X								
	9.5			RAPM109.5C6X								
	10.0			RAPM110C6X								
	12.0			RAPM112C6X								
2	10.0	6	3	RAPM210C6X	29	58	16.5	172	DPM2C6...*	172	APM2C6...*	174
	12.0			RAPM212C6X								
	12.7			RAPM212.7C6X								
	13.5			RAPM213.5C6X								
	14.0			RAPM214C6X								
	15.0			RAPM215C6X								
	16.0			RAPM216C6X								
	17.2			RAPM217.2C6X								
	18.0			RAPM218C6X								
3	15.0	6	3	RAPM315C6X	36	72	18.5	214	DPM3C6...*	214	APM3C6...*	216
	16.0			RAPM316C6X								
	17.2			RAPM317.2C6X								
	18.0			RAPM318C6X								
	19.0			RAPM319C6X								
	20.0			RAPM320C6X								
	21.3			RAPM321.3C6X								
	22.0			RAPM322C6X								
	23.0			RAPM323C6X								
	25.0			RAPM325C6X								
	25.4			RAPM325.4C6X								

Order codes for clamp halves:

Material	Interiour surface	Order code
Polypropylene	grooved	RAPM
	smooth	RAPGM
Polyamide	grooved	RANM
	smooth	RANGM
Rubber	smooth	RAVGM¹⁾

(Please exchange as required standard abbreviation RAPM in column for "Order code")

For flame- or corrosion retardant materials, please refer to page T5.

Different diameter on request.

¹⁾ When assembling solid rubber clamps, covering plates, hexagon screws and locking washers must be used.

*Please add the suffix below according to the surface/material required.

Order code suffixes		
Surface/material	Suffix	Example
Steel, phosphated	X	DPM1C6X
Steel, zinc plated, Cr(VI)-free	VZX	DPM1C6VZX
Stainless Steel 1.4571	4571X	DPM1C64571X

Multiclamp series A

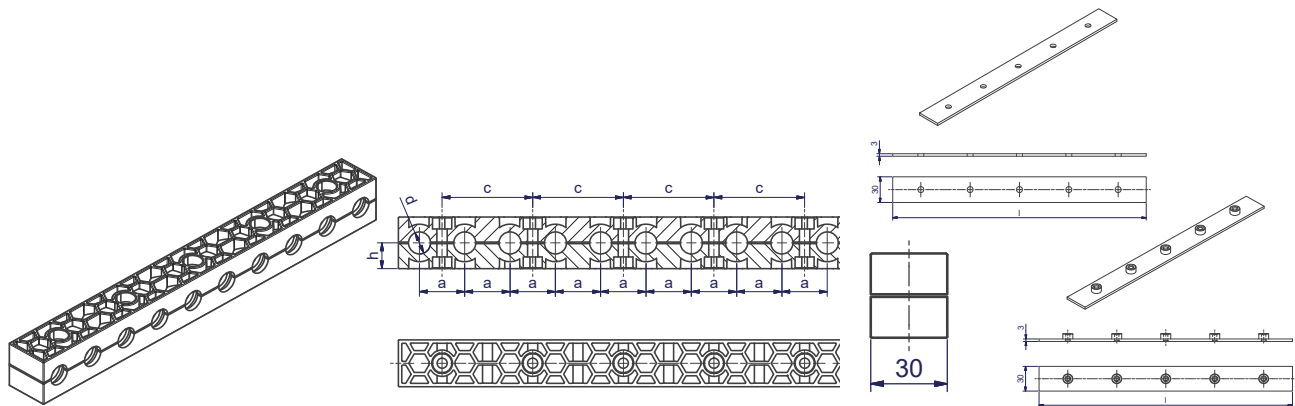

clamp size	Tube O.D. mm d	Number of tubes	Number of Fastening screws C	1 part 2 clamp halves RAPM Order code	2 clamp-halves RAPM-...				cover plate		weld plate	
					a	c	h	l	Order code	length:	Order code	length:
1	6.0	10	5	RAPM106E10X RAPM106.4E10X RAPM108E10X RAPM109.5E10X RAPM110E10X RAPM112E10X	20	40	13.5	196	DPM1E10...*	196	APM1E10...*	198
	6.4											
	8.0											
	9.5											
	10.0											
2	10.0	10	5	RAPM210E10X RAPM212E10X RAPM212.7E10X RAPM213.5E10X RAPM214E10X RAPM215E10X RAPM216E10X RAPM217.2E10X RAPM218E10X	29	58	16.5	288	DPM2E10...*	288	APM2E10...*	300
	12.0											
	12.7											
	13.5											
	14.0											
	15.0											
	16.0											
	17.2											
3	15.0	10	5	RAPM315E10X RAPM316E10X RAPM317.2E10X RAPM318E10X RAPM319E10X RAPM320E10X RAPM321.3E10X RAPM322E10X RAPM323E10X RAPM325E10X RAPM325.4E10X	36	72	18.5	358	DPM3E10...*	358	APM3E10...*	360
	16.0											
	17.2											
	18.0											
	19.0											
	20.0											
	21.3											
	22.0											
	23.0											
	25.0											
	25.4											

Order codes for clamp halves:

Material	Interior surface	Order code
Polypropylene	grooved	RAPM
	smooth	RAPGM
Polyamide	grooved	RANM
	smooth	RANGM
Rubber	smooth	RAVGM¹⁾

(Please exchange as required standard abbreviation RAPM in column for "Order code")

For flame- or corrosion retardant materials, please refer to page T5.

Different diameter on request.

¹⁾ When assembling solid rubber clamps, covering plates, hexagon screws and locking washers must be used.

*Please add the suffix below according to the surface/material required.

Order code suffixes		
Surface/material	Suffix	Example
Steel, phosphated	X	DPM1E10X
Steel, zinc plated, Cr(VI)-free	VZX	DPM1E10VZX
Stainless Steel 1.4571	4571X	DPM1E104571X

Tube clamps

Tube clamps series O

Order codes for clamps:

Material	Interior surface	Order code
Polypropylene	smooth	ROP
Polyamide	smooth	RON

Packing standard 100 pieces.

Areas of Application:

- pneumatics
 - automotive technology
 - mechanical engineering
 - measurement and control
 - naval technologie
- also suitable for cables and hoses.

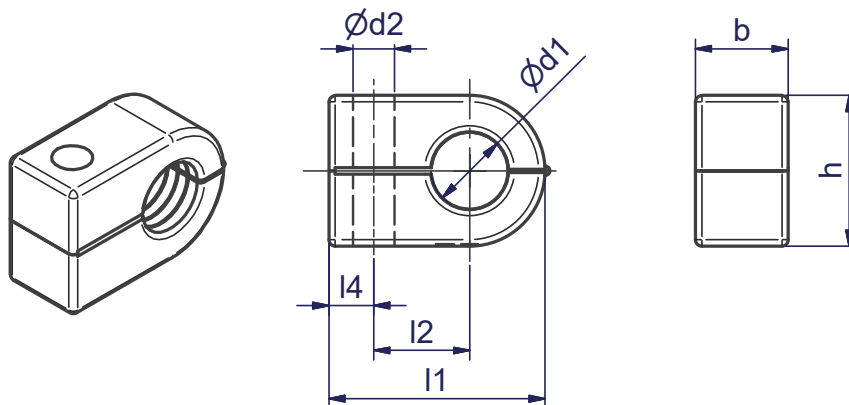

Clamp-size	O.D. mm	Tube Ø d1		Order code		l1	l2	l4	b	H	Ø d2	
		Tube NB	Inch	Polypropylene ROP	Polyamide RON							
1	6.0		1/4	ROP106X	RON106X	23	9	7	14.5	13.5	6.5	
	6.4			ROP106.4X	RON106.4X							
	8.0			ROP108X	RON108X							
2	8.0	G 1/8	3/8	ROP208X	RON208X	27	11	7	14.5	18.5	6.5	
	9.5				ROP209.5X							RON209.5X
	10.0				ROP210X							RON210X
	12.0			ROP212X	RON212X							
	12.7			ROP212.7X	RON212.7X							
3	10.0	G 1/8	1/2	ROP310X	RON310X	34	15	7	14.5	23.5	6.5	
	12.0				ROP312X							RON312X
	12.7	G 1/4	5/8	ROP312.7X	RON312.7X							
	13.5				ROP313.5X							RON313.5X
	14.0				ROP314X							RON314X
	15.0				ROP315X							RON315X
	16.0				ROP316X							RON316X
4	14.0	G 3/8	5/8	ROP414X	RON414X	40	19	6	14.5	30.5	6.5	
	15.0				ROP415X							RON415X
	16.0				ROP416X							RON416X
	17.2				ROP417.2X							RON417.2X
	18.0				ROP418X							RON418X
	19.0	G 1/2	3/4	ROP419X	RON419X							
	20.0				ROP420X							RON420X
	21.3				ROP421.3X							RON421.3X
	22.0				ROP422X							RON422X

Double-Tube clamps series O

Order codes for clamps:

Material	Interior surface	Order code
Polypropylene	smooth	ROPD
Polyamide	smooth	ROND

Different diameter on request.

Packing standard 100 pieces.

Areas of Application:

- pneumatics
 - automotive technology
 - mechanical engineering
 - measurement and control
 - machine tool industry
- also suitable for cables and hoses.

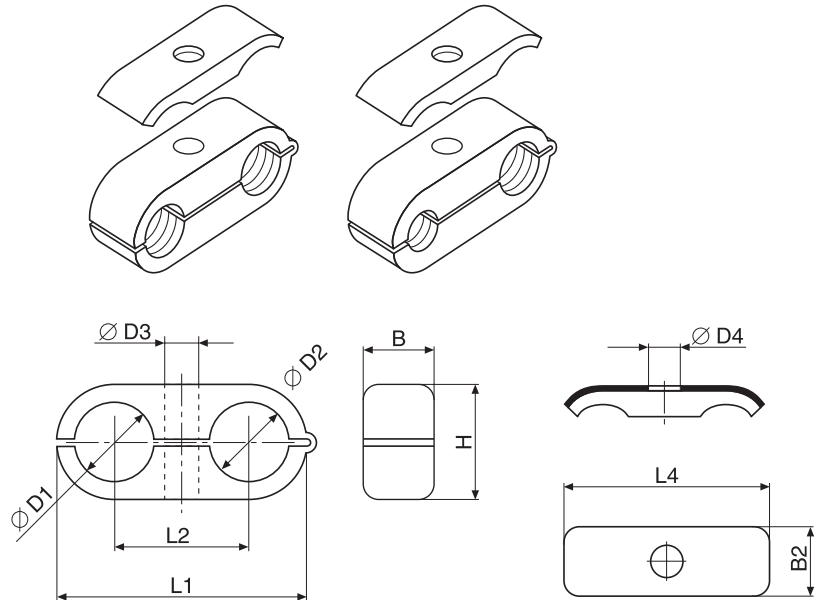

Clamp-size	Tube O.D. D1/D2			Order code		Order code		Order code		L1	L2	B	H	Ø D3	L4	B2	Ø D4
	mm	Tube NB	Inch	Polypropylene ROPD	Polyamide ROND	Cover plate DPO											
1	6.0		1/4	ROPD106X ROPD106.4X ROPD108X	ROND106X ROND106.4X ROND108X	DPO1X¹⁾ DPO14571X	32	18	14.5	13.5	6.5	29.0	16.3	6.5			
	6.4																
	8.0																
2	8.0	1/8	3/8	ROPD208X ROPD209.5X ROPD210X ROPD212X ROPD212.7X	ROND208X ROND209.5X ROND210X ROND212X ROND212.7X	DPO2X¹⁾ DPO24571X	41	22	14.5	18.5	6.5	40.0	16.3	6.5			
	9.5																
	10.0																
	12.0																
	12.7		1/2														
3	10.0	1/8	1/2	ROPD310X ROPD312X ROPD312.7X ROPD313.5X ROPD314X ROPD315X ROPD316X	ROND310X ROND312X ROND312.7X ROND313.5X ROND314X ROND315X ROND316X	DPO3X¹⁾ DPO34571X	54	30	14.5	23.5	6.5	50.5	16.5	6.5			
	12.0																
	12.7																
	13.5		1/4														
	14.0																
	15.0																
16.0	5/8																
4	14.0	3/8	5/8	ROPD414X ROPD415X ROPD416X ROPD417.2X ROPD418X ROPD419X ROPD420X ROPD421.3X ROPD422X	ROND414X ROND415X ROND416X ROND417.2X ROND418X ROND419X ROND420X ROND421.3X ROND422X	DPO4X¹⁾ DPO44571X	69	38	14.5	30.5	6.5	63.0	16.5	6.5			
	15.0																
	16.0																
	17.2																
	18.0																
	19.0		3/4														
	20.0																
	21.3																
	22.0		1/2														

¹⁾ Material = Steel, zinc plated, Cr(VI)-free

Hydraulic steel-clamps

Hydraulic steel-clamps

Order code **HSRS-***

W1: steel coating, Cr(VI)-free

* please add. Ø D

HSRS hydraulic steel-clamps are mainly used in the field of building machinery.

The support-block is welded to the machine body or another component either in upend or flat position. The tube-clamp is screwed on.

The robust construction of the clamp has an impact- and vibration-absorbing effect. The small dimension/height of the clamp allows hydraulic cables to be fitted later on – e. g. for installing additional equipment to building machinery.

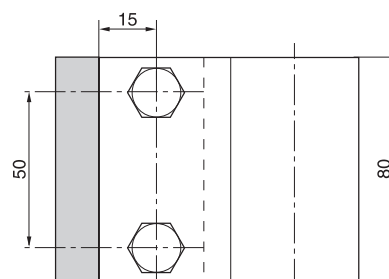
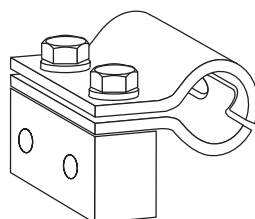
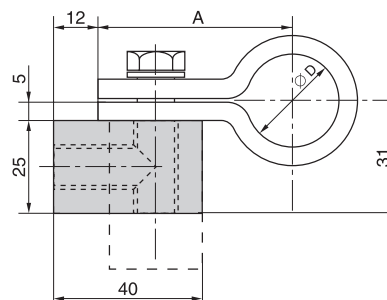
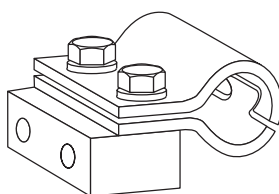

Order code		Dimensions	
Clamp incl. block	Clamp without block	Ø D	A
HSRS25	HSRS3-25CFX	25	52.5
HSRS30	HSRS3-30CFX	30	55.0
HSRS35	HSRS3-35CFX	35	57.5
HSRS38	HSRS3-38CFX	38	59.0
HSRS42	HSRS3-42CFX	42	61.0
HSRS48	HSRS3-48CFX	48	64.0
HSRS50	HSRS3-50CFX	50	65.0
HSRS60	HSRS3-60CFX	60	70.0

M12x30 DIN 933

A12 DIN 127

Hydraulic steel-clamps

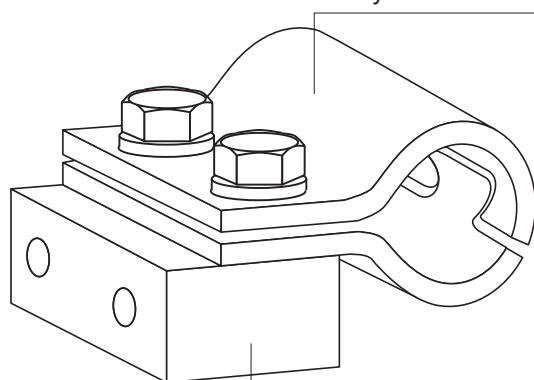

flat

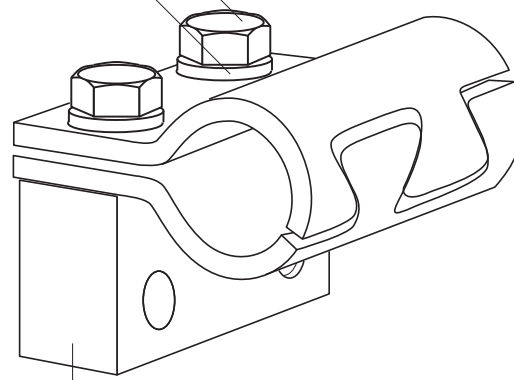

upend

support to welding

Hydraulic steel-clamps

Elastomere Inlay for HSRS

Order code EE-*
 * complete outside tube diameter

Hydraulic steel tube clamp HSRS
 also available with Elastomere inlay

The advantages:

- complete outside tube diameter
- Safe fastening method even for very sensitive tube and hoses lines
- Only one clamp for different tube diameters

Material:

Santoprene 64 Shore

- high oil and weathering resistance
- temperature stability between -40 °C and +120°C

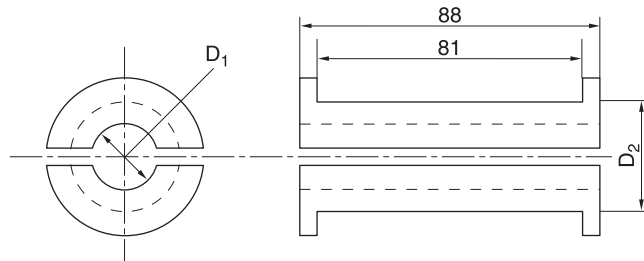

Order code Elastomere inlay	Nominal size D2	mm O.D. D1
EE12X	HSRS25	12
EE15X		15
EE20X	HSRS30	20
EE25X	HSRS35	25
EE30X	HSRS42	30
EE35X	HSRS50	35
EE38X		38
EE42X		42
EE47X	HSRS60	47
EE50X		50

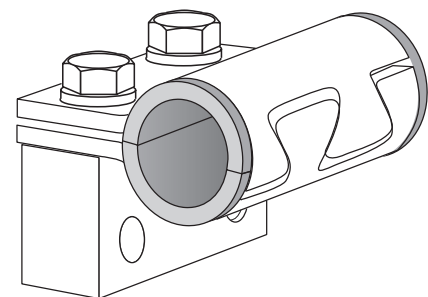
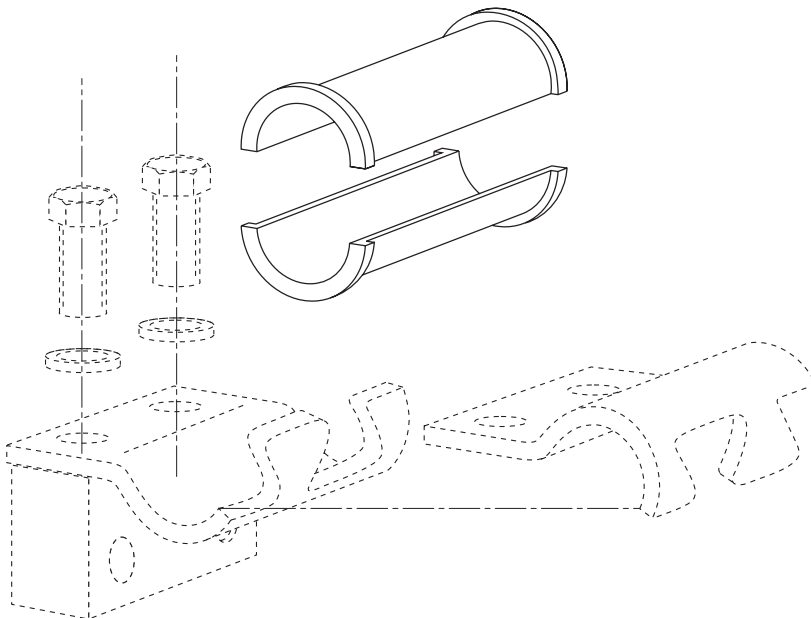

Tube Clamps with Elastomer Inlay Serie A

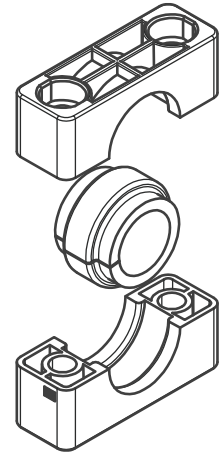

Clamp-halves

Order codes:

Polypropylene – **RAPE**
 Polyamide 6 – **RANE**

If required, replace the standard indicator RAPE in the order code columns.

Elastomer Inlay

Order code:

TPE 73° Shore – **EE***
 *complete with clamp size and outside tube diameter

Clamp size	Tube O.D.	Clamp body	Order code	Elastomer inlay
Serie A	mm		Clamp body with elastomer inlay	
4	6.0	RAPE4X	RAPE406X	EE206/406X
	8.0		RAPE408X	EE208/408X
	10.0		RAPE410X	EE210/410X
	12.0		RAPE412X	EE212/412X
	12.7		RAPE412.7X	EE212.7/412.7X
	14.0		RAPE414X	EE214/414X
	15.0		RAPE415X	EE215/415X
	16.0		RAPE416X	EE216/416X
	17.2		RAPE417.2X	EE217.2/417.2X
	18.0		RAPE418X	EE218/418X
	19.0		RAPE419X	EE219/419X
5	20.0	RAPE5X	RAPE520X	EE520X
	22.0		RAPE522X	EE522X
	25.0		RAPE525X	EE525X
	28.0		RAPE528X	EE528X
	30.0		RAPE530X	EE530X
6	20.0	RAPE6X	RAPE620X	EE320/620X
	21.3		RAPE621.3X	EE321.3/621.3X
	22.0		RAPE622X	EE322/622X
	23.0		RAPE623X	EE323/623X
	25.0		RAPE625X	EE325/625X
	26.9		RAPE626.9X	EE326.9/626.9X
	28.0		RAPE628X	EE328/628X
	30.0		RAPE630X	EE330/630X
	32.0	RAPE632X	EE332/632X	
	35.0	RAPAE6X	RAPE635X	EE635X
	38.0		RAPE638X	EE638X
	42.0		RAPE642X	EE642X
	45.0		RAPE645X	EE645X

Attention! For clamps with elastomer inlay, the relation of diameter and size is not identical with the profile design or smooth design.

Tube Clamps with Elastomer Inlay Serie C

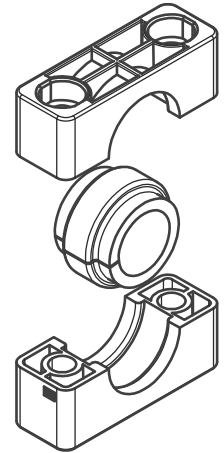

Clamp-halves

Order codes:

Polypropylene – **RCPE**

Polyamide 6 – **RCNE**

If required, replace the standard indicator RCPE in the order code columns.

Elastomer Inlay

Order code:

TPE 73° Shore – **EE***

*complete with clamp size and outside tube diameter

Clamp size Serie C	Tube O.D. mm	Clamp body	Order code Clamp body with elastomer inlay	Elastomer inlay
2	6.0	RCPE2X	RCPE206X	EE206/406X
	8.0		RCPE208X	EE208/408X
	10.0		RCPE210X	EE210/410X
	12.0		RCPE212X	EE212/412X
	12.7		RCPE212.7X	EE212.7/412.7X
	14.0		RCPE214X	EE214/414X
	15.0		RCPE215X	EE215/415X
	16.0		RCPE216X	EE216/416X
	17.2		RCPE217.2X	EE217.2/417.2X
	18.0		RCPE218X	EE218/418X
	19.0		RCPE219X	EE219/419X
3	20.0	RCPE3X	RCPE320X	EE320/620X
	21.3		RCPE321.3X	EE321.3/621.3X
	22.0		RCPE322X	EE322/622X
	23.0		RCPE323X	EE323/623X
	25.0		RCPE325X	EE325/625X
	26.9		RCPE326.9X	EE326.9/626.9X
	28.0		RCPE328X	EE328/628X
	30.0		RCPE330X	EE330/630X
	32.0		RCPE332X	EE332/632X
	4		32.0	RCPE4X
33.7		RCPE433.7X	EE433.7X	
35.0		RCPE435X	EE435X	
38.0		RCPE438X	EE438X	
40.0		RCPE440X	EE440X	
42.0		RCPE442X	EE442X	
45.5		RCPE445.5X	EE445.5X	
48.0		RCPE448X	EE448X	
51.0		RCPE451X	EE451X	
53.4		RCPE453.4	EE453.4X	
56.4		RCPE456.4X	EE456.4X	
60.3	RCPE460.3X	EE460.3X		
5	57.0	RCPE5X	RCPE557X	EE557X
	60.3		RCPE560.3X	EE560.3X
	63.5		RCPE563.5X	EE563.5X
	65.0		RCPE565X	EE565X
	70.0		RCPE570X	EE570X
	73.0		RCPE573X	EE573X
	76.1		RCPE576.1X	EE576.1X

Attention! For clamps with elastomer inlay, the relation of diameter and size is not identical with the profile design or smooth design.

Tube Clamps with Elastomer Inlay Serie C

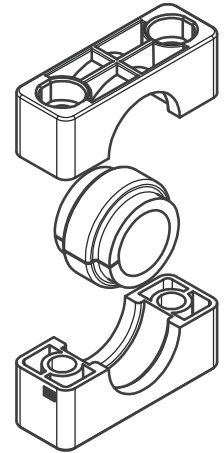

Clamp-halves

Order codes:

Polypropylene – **RCPE**
 Polyamide 6 – **RCNE**

If required, replace the standard indicator RCPE in the order code columns.

Elastomer Inlay

Order code:

TPE 73° Shore – **EE***
 *complete with clamp size and outside tube diameter

Clamp size Serie C	Tube O.D. mm	Order code		
		Clamp body	Clamp body with elastomer inlay	Elastomer inlay
6	80.0	RCPE6X	RCPE680X	EE680X
	82.5		RCPE682.5X	EE682.5X
	88.9		RCPE688.9X	EE688.9X
	100.0		RCPE6100X	EE6100X
	101.6		RCPE6101.6X	EE6101.6X
7	101.6	RCPE7X	RCPE7101.6X	EE7101.6X
	108.0		RCPE7108X	EE7108X
	114.3		RCPE7114.3X	EE7114.3X
	127.0		RCPE7127X	EE7127X
	133.0		RCPE7133X	EE7133X

Attention! For clamps with elastomer inlay, the relation of diameter and size is not identical with the profile design or smooth design.

Fixed Adaptor

Compatibility with channel rails

Hilti (Channel system MQ for medium load)	Halfen (Medium duty channel system)	Unistrut®
MQ-21, MQ-21U, MQ-21D	HM 41/22, HL 41/22, HM 41/22 D	P1000, P1000T, P1001, P1001T
MQ-31	HZM 41/22, HZL 41/22, HZM 41/22 D	P2000, P2000T
MQ-41, MQ-41U, MQ-41D	HM 41/41, HL 41/41, HM 41/41 D	P3300, P3300T10, P3301, P3301T10
MQ-52, MQ-52-72D	HZM 41/41, HZL 41/41, HZM 41/41 D	P4000, P4000T10
MQ-72, MQ-72U	HM 41/62, HL 41/62, HM 41/62 D	P5000T, P5001T, P5500T, P5501T
	HM 41/83, HL 41/83	

Please contact us to check compatibility with additional types of channel rails.

Fixed Adaptor for Series A

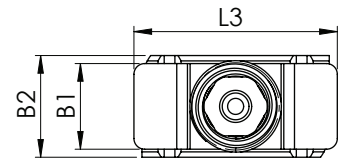
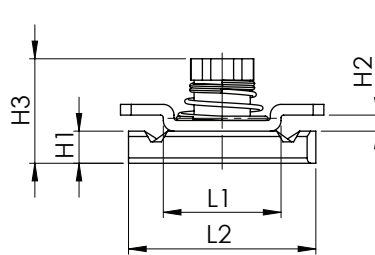
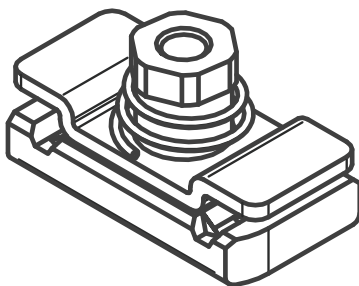

clamp size	Fixed adaptor BAA/BAB Order code	dimensions:								
		L1	L2	L3	B1	B2	H1	H2	H3	d6
1	BAA/BAB1VZX BAA/BAB14571X	22	35	38	16	19	6	3	19.5	M6
2										
3										
4										
5										
6										
7										
8										

Fixed Adaptor for Series B

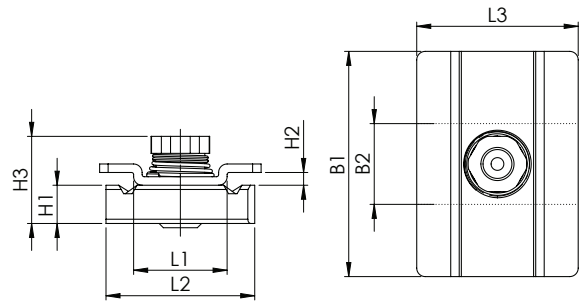
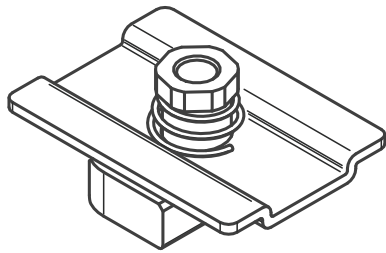

clamp size	Fixed adaptor BAB Order code	dimensions:								
		L1	L2	L3	B1	B2	H1	H2	H3	d6
1	BAA/BAB1VZX BAA/BAB14571X	22	35	38	16	19	6	3	23.5	M6
2	BAB2VZX BAB24571X				53		9			
3										
4	BAB4VZX BAB44571X				80					
5										

Fixed Adaptor for Series C

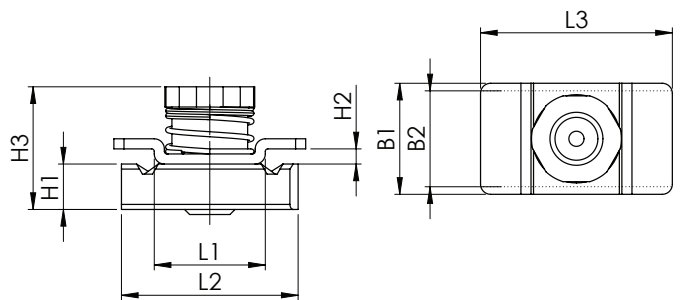
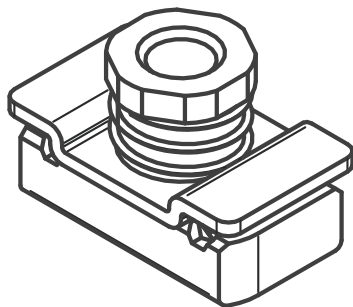

clamp size	Fixed adaptor BAC Order code	dimensions:											
		L1	L2	L3	B1	B2	H1	H2	H3	d6			
1	BAC1VZX BAC14571X	22	35	38	22	19	9	3	24.3	M10			
2													
3													
4	BAC4VZX BAC44571X			45	25							25.8	M12

Recommended screw lengths when using fixed adaptor for series C

clamp size	Hexagon head screw (with cover plate)	Hexagon socket head screw (without cover plate)	Stacking bolt
1	M10 x 40	M10 x 20*	M10 x 20*
2	M10 x 55*	M10 x 35*	M10 x 35*
3	M10 x 65*	M10 x 50*	M10 x 50*
4	M12 x 100	M12 x 75*	M12 x 75*

*For screws with special length (different from catalogue) price on request.

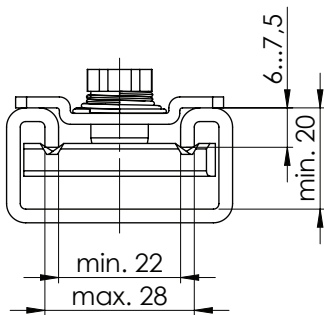

Railnut with loss protection

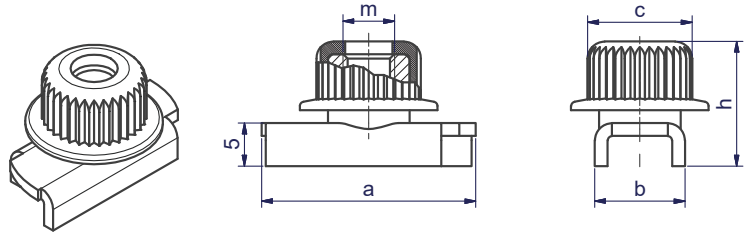

Rail nut light series TMA/B1 Order code	Dimensions:				
	a	b	c	m	h
TMA/TMB1WLPVZX	24.9	10.5	12	M6	14.5
TMA/TMB1WLP71X	24.9	10.5	12	M6	14.5

The big flange prevents that the railnut falls into the rail during installation and has a vibration and sound insulating function.

The rubbercap has an integrated screw locking device. Fast and easy to install, easy to adjust, especially for vertical installations.

Advantages:

- 40% time savings during installation
- Fast and easy to install
- Vibration and sound insulating function
- Especially for vertical installations



Custom Products



What are Custom Products?

Parker – supplier of your wishes – your special is our standard!

Your idea is our Know-How!

Profit of the advantages of our Custom Products:

- Slogans like “single source“ or “vendor-reduction“ are getting more and more important in industry.
- worldwide availability
- Parker TFDE Custom Products is able to offer almost every type of connector, which is not to be found in our catalogues or price-lists.

Following examples could be a suggestion, how your problems could be solved in the future.

Jump sizes



One connector can replace several combinations.

- to shorten assembly-time
- to reduce possible leaks and their costs
- to reduce stock

Extra-long connectors



to avoid long tubes
or adapter-combinations

Unconventional configuration of ends



tube and port end

eg: to connect metric and inch tube ...

Restricted orifice



orifice × 0,3 mm

(technical clarification about length of reduced bore in accordance to material necessary)

Industrial Tube Fittings Europe – Alphanumerical index

Order code	Page	Order code	Page	Order code	Page
0107	O46	C6BU	L8	EGE-NPT	I64
0207	O49	C6MK4	O31	EGEO	I59
0507	O51	C6MLO	J19	EGE-R-ED	I61
1004	H32	C6MX	K18	EL	I30
2107	O47	C87OMLO	J38	ELA/ELAE	P64/65
2207	O50	C87OMX	K45	EL-M-ED	I71
226B	H51	C8OMLO	J42	EL-R-ED	I72
226Z	H51	C8OMX	K49	EMA1	R4
2507	O52	CBU	L12	EMA3	R8
3107	O48	CC5OLO	J40	EMK4	O28
3507	O53	CC5OX	K47	EMLO	J10
AKL	H7	CCCTX	K52	EMTX	K10
AOE4G	O18	CCTX	K51	EO2-FORM F3	H24
AOEG	O18	CD45	O10	EO2-FORM PRO22	H24
AOEL6	J18	CDM	O9	EO2-FORM SET	I12
AP	N70	CLO	J43	EO-KARRYFORM	H25
AS	M3	CMTX	K50	EO-KARRYMAT	H11
AS	N35	CPM	N69	EOMAT ECO	H13
ASK	M5	CR	O5	EOMAT PRO	H21
ASL	N37	D	I15	EOMAT UNI	H15
ASR	N34	DA	I34	EO-NIROMONT	H49
AV 6/42	H50	DD45	O14	ES	N39
BAV 6/12	H51	DD	O14	ESL	N41
BBMTX	K22	DG 101	Q6	ESV	M6
BFG	N75	DG 102-M	Q8	ET	I29
BFGL	N78	DG 102-R	Q7	ET-M-ED	I69
BFW	N76	DG 103	Q9	ET-R-ED	I70
BFW3	N77	DG 104-M	Q11	EV	I28
BFW3-G	N85	DG 104-R	Q10	EVGE-M-ED	I62
BFW-G	N80	DG 105	Q12	EVGE-R-ED	I63
BFW-GI	N81	DG 106-M	Q14	EVL	I33
BFWL	N79	DG 106-R	Q13	EVL-M	I77
BFW-S	N82	DG 107	Q15	EVL-R	I78
BL	J5	DG 108	Q16	EV-M-ED	I67
BML	J5	DG 208	Q17	EV-R-ED	I68
BMTX	K6	DKA	I128	EVT	I32
BTX	K5	DKI	I125	EVT-M	I75
BU	L5	DMTX	K75	EVT-R	I76
BUZ	I116	DOZ	I121	EVW	I31
BUZM	I117	DPR	I16	EVW-M	I73
BV 20/25	H53	DV	P60	EVW-R	I74
BV 6/18	H52	DVGE-M	Q19	EW	I27
C3MX	K53	DVGE-R	Q18	EW-M-ED	I65
C3P4	O57	DVWE-M	Q21	EW-R-ED	I66
C3T4	O55	DVWE-R	Q20	F3HG5	O23
C4OMLO	J41	E	I120	F3MK4	O38
C4OMX	K48	E6MK4	O35	F3P4	O57
C5BU	L12	EBU	L6	F3T4	O54
C5OMLO	J39	ED	I122	F3MX	K36
C5OMX	K46	EGE-M-ED	I60		

Industrial Tube Fittings Europe – Alphanumerical index

Order code	Page	Order code	Page	Order code	Page
F42EDMLO.....	J30	FUS	N17	HP46	O56
F42EDMX	K30	FUSF	N20	HP5ON	O22
F4OHG5	O24	FUSM	N18	HPBA.....	J71
F4OMX	K32	G.....	I18	HPM	O16
F5BU	L10	G3P4	O59	HVM-B.....	H9
F5OG.....	O17	G4MK4	O37	I-TL.....	P20
F5OG5.....	O19	G4MLOSMO.....	J57	J6MK4	O36
F5OHAO.....	O20	G4MX	K72	JBU	L7
F5OMLO.....	J27	G4MXMO	K79	JMK4	O28
F5OMX	K27	G5G5JG5	O20	JMLO.....	J11
F63P4	O58	G63P4	O59	JMTX	K11
F63MX.....	K44	G6X	K78	JX6	K25
F642EDML	J36	G87MLO.....	J56	K.....	I24
F642EDMX	K39	GAI-M.....	I104	K6OO4MX	K84
F64OMX	K40	GAI-NPT.....	I106	K6PP4MX.....	K85
F65OL.....	J35	GAI-R	I105	KARRYFLARE	H34
F65OMX	K38	GBU.....	L13	KD	I127
F682EDML	J37	GE-M.....	I54	KDS	I126
F682EDMX	K41	GE-M (KEG).....	I55	KH (71)	P41
F687OML	J34	GE-M-ED.....	I48	KH (S)	P40
F687OMX	K37	GE-NPT	I57	KH 3/2 (71)	P47
F68OMX	K42	GEO.....	I47	KH 3/2 (S).....	P46
F6MK4.....	O30	GE-R.....	I51	KH 3/2 BSPP (71).....	P49
F6MX.....	K43	GE-R (KEG)	I53	KH 3/2 BSPP (S)	P48
F82EDMLO.....	J32	GE-R-ED	I49	KH 3/2 NPT (S).....	P50
F82EDMX	K33	GE-UNF/UN	I56	KH-A (S)	P53
F87OMLO.....	J26	GFS	N21	KH BSPP (71).....	P43
F87OMX	K26	GFS-G	N25	KH BSPP (S).....	P42
F8OHG5	O25	GFS-N	N27	KH-B1V-S.....	P52
F8OMX	K34	GG	O13	KHBLOCK	P55
FBU	L11	GG44M.....	O41	KHBLOCK 3/2.....	P56
FF33M	O44	GHP.....	H19	KHLOCKING	P51
FF42EDMLO.....	J31	GHP PRO	H23	KH-NPT (71).....	P45
FF42EDMX	K31	GM	I118	KH-NPT (S).....	P44
FF5OMLO.....	J28	GMA1	R5	KH-T (S).....	P54
FF5OMX	K29	GMA3	R9	KLO	J12
FFFM	O6	GMTX	K73	KMMOO	O15
FF	O4	GR	I19	KONU	H19
FGM	O8	GZ	I44	KOR.....	I39
FHS	N16	GZR.....	I45	KTX.....	K12
FHSF	N19	H6MK4	O34	L(O)EMQ.....	N29
FLO.....	J33	HBU.....	L6	L(O)HQ	N28
FM.....	I10	HHP.....	O16	L(O)VQ.....	N30
FMK4.....	O40	HL6.....	J25	LD.....	P61
FMTX.....	K35	HMK4	O26	LEE	I80
FNLBA.....	J69	HMLO.....	J9	LE-M.....	I100
FNMK4	O39	HP4	O56	LE-M (KEG)	I103
FNML.....	J63	HMTX	K9	LE-R	I101
FNMTX	K86	HMX6	K24	LE-R (KEG).....	I102
FNU	L13	HP3M	O45	LOHB3.....	J62

Industrial Tube Fittings Europe – Alphanumerical index

Order code	Page	Order code	Page	Order code	Page
LOHL6	J24	PDFS-G	N64	RHDI	P18
LOHMX6	J67	PDFS-S	N66	RHDMLOS	P22
LOHMX6	K90	PDSF-B	N92	RHDMTXS	P29
LOHU86	J68	PEFF-G	N45	RHV42EDMLOS	P23
LUBSS	H49	PEFF-N	N48	RHV42EDMXS	P30
M	I14	PF	N83	RHV50MLOS	P25
MAV	I109	PFB	N84	RHV50MXS	P32
MAVE	I110	PFE	N84	RHV82EDMLOS	P27
MAV-MA1	R7	PFF-..S/L	N49	RHV82EDMXS	P34
MAV-MA3	R11	PFF-G	N42	RHV-M-ED	P16
MAVMD..MA3	R11	PFF-N	N46	RHV-R-ED	P14
MMO	O15	PFL	N83	RHZ42EDMLOS	P24
MMO444M	O42	PGFS-B	N58	RHZ42EDMXS	P31
MMS	O12	PGFS-S	N61	RHZ50MLOS	P26
MOK	H19	PMQ	N71, N72	RHZ50MXS	P33
MOKEO2	H19	PNLOBA	J70	RHZ82EDMLOS	P28
MOKEO2PRO	H23	PNMK4	O29	RHZ82EDMXS	P35
MOKPRO	H23	PNMLO	J64	RHZ-M-ED	P17
MOKPRORW	H23	PNMTX	K87	RHZ-R-ED	P15
MRO	O11	PNU	L14	RI	I108
MTX	K77	PORTBOARD A	H59	RI-ED	I107
OR	I123	PORTBOARD B	H59	RMTX	K70
OTX	K76	PRF	N74	ROV	I111
P5ONBA	J71	PSFA-B	N89	RRS	O5
P5ONM	O21	PSF-B	N91	RVP	P19
PAFG-90G	N52	PSFC	N88	S	I17
PAFG-90L	N56	PSFP	N90	S3MX	K65
PAFG-90M	N50	PSR	I15	S4OMLO	J50
PAFG-90X	N54	PTR34M	O43	S4OMX	K62
PAFG-G	N51	PTRM	O7	S5OMLO	J49
PAFG-L	N55	PWDA	N87	S5OMX	K61
PAFG-X	N53	PWDS-G	N86	S6BU	L8
PAFS-90B	N59	R3MX	K71	S6MK4	O33
PAFS-90S	N63	R4OMLO	J54	S6MLO	J21
PAFS-B	N57	R4OMX	K68	S6MX	K20
PAFSF-G	N44	R5OMLO	J53	S87OMLO	J48
PAFSF-S	N62	R5OMX	K67	S87OMX	K60
PAFS-S	N60	R6BU	L9	S8OMLO	J51
PAGL-(G/M)	N73	R6MK4	O32	S8OMX	K63
PARFLANGE® 1025	H39	R6MLO	J22	SBR	J75
PARFLANGE® 50	H41	R6MX	K21	SKA	M7
PARFLANGE® 50 BASIC	H42	R6O4MX	K82	SKA-ORB	M10
PARFLANGE® 50 PRO	H43	R6P4MLO	J61	SKAR	M8
PARFLARE ECO	H35	R6P4MX	K83	SKA-RB	M11
PAR-LOK	H54	R87OMLO	J52	SMA1	R7
PCCFF	N68	R87OMX	K66	SMA3	R11
PCFF	N67	R8OMLO	J55	SMTX	K64
PCFF-G	N43	R8OMX	K69	SV	I25
PCFF-N	N47	RED	I35	SWVE	I89
PDFS-B	N65	RHD	P13	T	I21

Industrial Tube Fittings Europe – Alphanumerical index

Order code	Page	Order code	Page	Order code	Page
TEE.....	I80	WBU.....	L7		
TE-M.....	I96	WEE.....	I80		
TE-M (KEG).....	I99	WEE-R.....	I79		
TE-R.....	I97	WE-M.....	I93		
TE-R (KEG).....	I98	WE-M(KEG).....	I92		
TFDE-SAMPLECASE.....	H60	WEMLO.....	J14		
TH-M.....	I86	WEMTX.....	K14		
TH-M-KDS.....	I85	WE-NPT.....	I91		
TH-R.....	I88	WE-R.....	I94		
TH-R-KDS.....	I87	WE-R (KEG).....	I95		
TL.....	J7	WF5OLO.....	J29		
TPL.....	J6	WFS.....	N23		
TR.....	I22	WFS-G.....	N26		
TRBU.....	L9	WGMTX.....	K74		
TRMLO.....	J23	WH-M.....	I82		
TRMTX.....	K23	WH-M-KDS.....	I81		
TT4ML.....	J58	WH-R.....	I84		
TT4MX.....	K80	WH-R-KDS.....	I83		
TT8ML.....	J59	WJJLO.....	J17		
TTP4ML.....	J60	WJJTX.....	K17		
TTP4MX.....	K81	WJLO.....	J16		
TU.....	L5	WJTX.....	K16		
TW3L.....	J72	WLN.....	K91		
TX.....	K7	WLNML.....	J72		
V3MX.....	K59	WMK4WL4NM.....	O27		
V3P4.....	O58	WMLO.....	J13		
V3T4.....	O55	WMTX.....	K13		
V4OMLO.....	J46	WNLO.....	J15		
V4OMX.....	K56	WNTX.....	K15		
V5OMLO.....	J45	WSV.....	I26		
V5OMX.....	K55	WV.....	P63		
V6LO.....	J20	WZK.....	H55		
V6MX.....	K19	XEMQ.....	N32		
V87OMLO.....	J44	XHML6.....	J66, K89		
V87OMX.....	K54	XHMLO.....	J65, K88		
V8OMLO.....	J47	XHQ.....	N31		
V8OMX.....	K57	XVQ.....	N33		
VDHA.....	P62				
VEE.....	I80				
VH.....	I119				
VKA.....	I114				
VKA1.....	R6				
VKA3.....	R10				
VKAM.....	I115				
VMTX.....	K58				
VOMO.....	H5				
VSTI M/R-ED.....	I113				
VSTI M-OR.....	I112				
W.....	I20				
WAS.....	M4, N38				