

BDH SERIES PORTABLE ELECTRIC BLOWER HEATERS

- HEAVY DUTY FINTUBE METAL SHEATH HEATING ELEMENT
- UL AND CSA APPROVED
- 10.0, 15.0, AND 30.0 KW HEAT OUTPUTS AVAILABLE
- VOLTAGES INCLUDE 208, 240, 480
- FAN ONLY OPERATION FOR SUMMER COOLING
- SINGLE AND THREE PHASE OPERATION
- SHIPPED FULLY ASSEMBLED
- SAFE TO OPERATE IN UNATTENDED AREAS



threat of poisoning from combustion by-products, associated with fuel fired heaters. Practical uses are factories, enclosed areas where the ceiling height is no higher than 15 feet, assembly areas, enclosed smoking areas, building construction where "localized" temporary heat is needed, and repair stations are just a few examples of where BDH Series portable blower heaters can be used.

DESCRIPTION

The BDH Series portable electric blower heater is an excellent choice to heat areas that are indoors and enclosed with ceiling heights of 15 feet or less. The brightly painted heater enclosure is a structural frame consisting of two spun rings and two formed channels that support a 20 gauge steel cylinder. The enclosure is phosphate coated for corrosion resistance, and finished

in powder coat paint. The heating cylinder pivots vertically to direct airflow. The BDH Series has five wattage outputs to choose from and starting as low as 7.5KW.

The built-in safety features include an adjustable thermostat (range 40°F to 100°F) to control the outlet air temperature, auto-reset thermal cutouts for the fan motor and heating elements. The thermostat provides settings for full OFF, fan only, and temperature control in the heating setting.

BDH Series heaters feature a large, easily accessible control and wiring compartment containing a 3 pole magnetic contactor; a 120-volt control transformer and motor starter that provides additional safety on 480 and 600-volt models. Front and rear grilles are 10 gauge finished black powder coat and are designed to meet OSHA safety requirements.

APPLICATIONS

The high output, industrial grade, portable electric blower is a working monster. The BDH series heater can be left unattended without the

CATALOG NUMBER	KW	VOLTS	BTUH	PH	AMPS	DIMENSIONS	SHIP WT.	AVAIL.
BDH1021A	10	240	34,120	1	41.7	40"H X 30"W X 24"D	65 lbs	S
BDH1021CKA	10	240	34,120	1	41.7	40"H X 30"W X 24"D	65 lbs	S
BDH1583A	15	208	51,180	3	41.8	40"H X 30"W X 24"D	65 lbs	NS
BDH1521A	15	240	51,180	1	62.5	40"H X 30"W X 24"D	65 lbs	NS
BDH1523A	15	240	51,180	3	36.3	40"H X 30"W X 24"D	65 lbs	NS
BDH1543A	15	480	51,180	3	31.2	40"H X 30"W X 24"D	65 lbs	S
BDH3043A	30	480	102,360	3	36.3	40"H X 30"W X 24"D	75 lbs	NS

NOTE: BDH1021CKA includes cord & plug kit packaged inside heater carton.

CATALOG NUMBER	WIRE SIZE/TYPE	LENGTH OF CABLE	FOR USE WITH HEATER MODEL	SHIP WT.
DHCWM*	-	-	Ceiling and wall bracket can be used on all models	20 lbs
SCS25043	4/3 SO	25'	DH1521A	22 lbs
SCS10063	6/3 SO	10'	DH1021A (10ft long w/plug)	18 lbs
SCS25064	6/4 SO	25'	DH1583A, DH1523A, DH3043A	20 lbs
SCS25124	12/4 SO	25'	DH15443A	10 lbs

DIMENSIONS

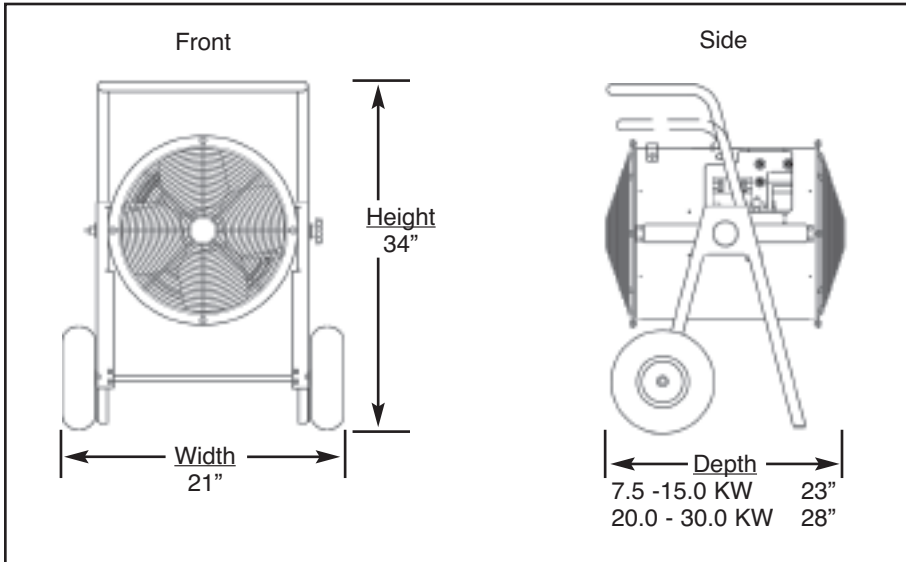

Note: All models are factory wired for 3 phase operation. Models designated 1 and 3 phase can be field wired for single phase operation.

CORD SET FOR INDUSTRIAL ELECTRIC BLOWERS

CATALOG NUMBER	Wire Size/Type
BCS25144	14/4 SO
BCS25124	12/4 SO
BCS25103	10/3 SO
BCS25104	10/4 SO
BCS25083	8/3 SO
BCS25084	8/4 SO
BCS25063	6/3 SO
BCS25064	6/4 SO
BCS25044	4/4 SO

PLUG SET FOR INDUSTRIAL ELECTRIC BLOWERS

CATALOG NUMBER	Plug Type	1P or 3P
BLPS25144	L14-20	3
BLPS25124	L15-20	3
BLPS25103	L15-30	1
BLPS25104	L16-30	3
BLPS25083	L3763C	1
BLPS25084	L17-30	3
BLPS25063	L6-50	1
BLPS25064	L3764C	3
BLPS25044	L3765C	3

