

ML2-C



UPC Code: 07847798729

Country of Origin: United States - *Eligible for ARRA funded projects

Configuration:



Locking Wiring Devices

Brand Features

Leviton's Black & White Midget line of industrial grade locking blade plugs and connectors are feature rugged construction that resists impact, sunlight, chemicals and rough use. All contacts are solid one-piece construction for superior conductivity. The ergonomic, fluted-body design with radial gripping edge is ideal for gripping and pulling. The unique cord clamp accepts a wide range of cord sizes, providing a secure grip without damaging the cord. And, they are backed by a limited lifetime warranty.

Item Description

15 Amp, 125 Volt, NEMA ML2R, 2P, 3W, Locking Connector, Industrial Grade, Grounding, MiniLock - BLACK-WHITE

Technical Information

Electrical Specifications

Grounding: Grounding

Amperage: 15 Amp

Voltage: 125 Volt

NEMA: ML2R

Pole: 2

Wire: 3

Dielectric Voltage: Withstands 2000V per UL498

Current Interrupting: Certified for current interrupting at full rated current

Temperature Rise: Max 30C at 250 cycles OL at 200 pct rated current

Environmental Specifications

Flammability: Rated HB or better UL94

Operating Temperature: -40C to 60C

Material Specifications

Body Material: Impact Modified Nylon

Back Cover: Thermoplastic

Wire Module: Nylon

Cord-Clamp: Nylon

Clamp Insert: Nylon

Blades/Contacts: Solid Brass

Terminal Screws: Brass

Assembly Screws: Steel, Zinc Plated

Color: Black-White

Mechanical Specifications

Terminal ID: Brass-Hot, Green-Ground, Silver-Neutral

Terminal Accom.: 18-14 AWG

Product ID: Ratings and NEMA I.D. permanently marked on device

Cord Range: .218 - .430

Wire Gauge: 18-14 AWG

Product Features

Feature: MiniLock

Color: Black-White

Standards and Certifications

NEMA: WD-6

ANSI: C-73

UL Fed Spec WC-596: File E13393

CSA C22.2 No. 42: File LR-406

NOM: 057

Warranty: Lifetime Warranty

*May include one or more globally sourced components.

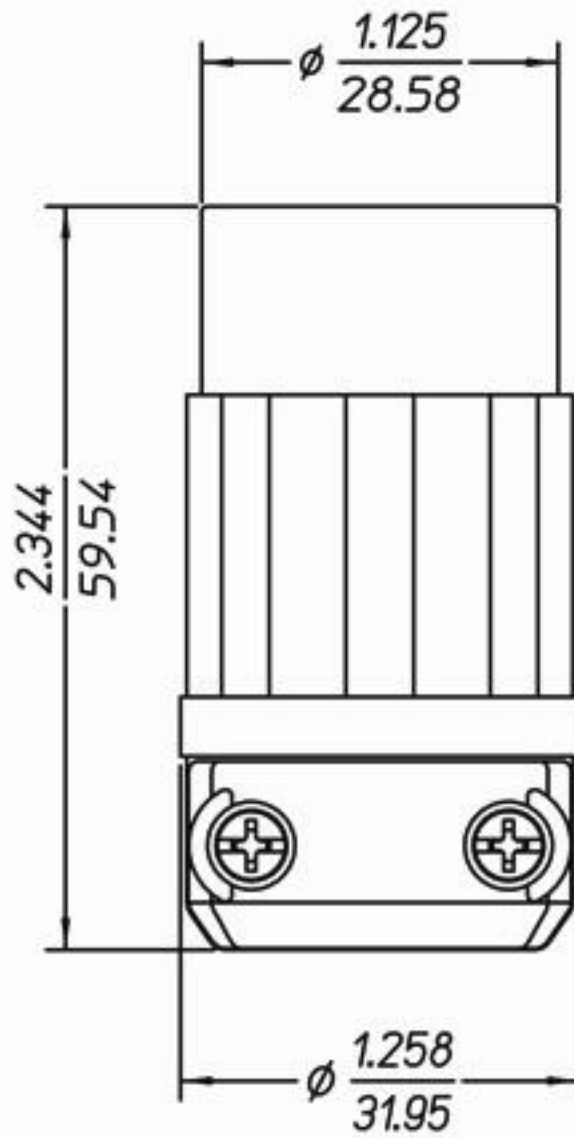

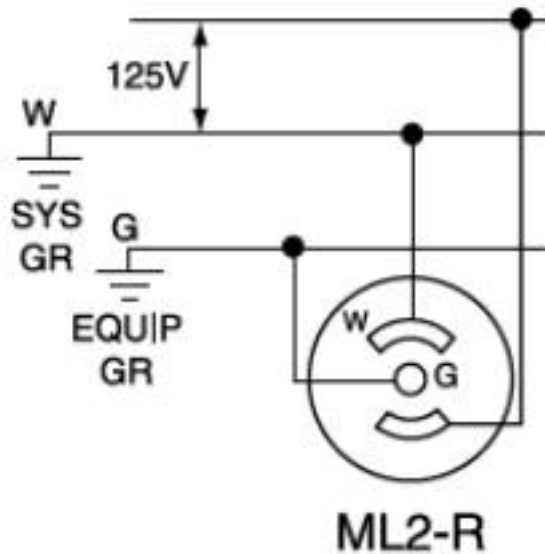

SPECIFICATION SUBMITTAL

JOB NAME: <input style="width: 95%; height: 20px;" type="text"/>	CATALOG NUMBERS: <input style="width: 95%; height: 20px;" type="text"/>	
JOB NUMBER: <input style="width: 80%; height: 20px;" type="text"/>	<input style="width: 95%; height: 20px;" type="text"/>	<input style="width: 95%; height: 20px;" type="text"/>

Leviton Manufacturing Co., Inc.
 201 North Service Road, Melville, NY 11747
 Telephone: 1-800-323-8920 · FAX: 1-800-832-9538 · Tech Line (8:30AM-7:30PM E.S.T. Monday-Friday): 1-800-824-3005

Leviton Manufacturing of Canada, Ltd.
 165 Hymus Boulevard, Pointe Claire, Quebec H9R 1E9 · Telephone: 1-800-469-7890 ·
 FAX: 1-800-824-3005 · www.leviton.com/canada

Leviton S. de R.L. de C.V.
 Lago Tana 43, Mexico DF, Mexico CP 11290 · Tel.: (+52)55-5082-1040 · FAX: (+52)5386-1797 · www.leviton.com.mx

Visit our Website at: www.leviton.com
 © 2012-2016 Leviton Manufacturing Co., Inc. All rights reserved. Subject to change without notice.



Leviton has a global presence.
 If you would like to know where your local Leviton office is located please go to: www.leviton.com/international/contacts/

**Buy American Compliant Logo -- The American Recovery And Reinvestment Act of 2009 ("ARRA") provides federal grants and loans for projects throughout the country. Section 1605 of the Act, named the "Buy American" provision, requires that certain materials and manufactured products used in projects funded by the Act be manufactured in the United States. The appearance of the Recovery Act Logo in relation to a Leviton product is only intended to reflect that such product may be used in an ARRA funded project. It does not mean that such product or Leviton is sponsored or endorsed by, or that Leviton receives funds from, the federal government or the Recovery Accountability and Transparency Board. Nothing in Leviton's use of the logo is intended to suggest anything regarding the requirements for funding under ARRA.*