

# ML1-PER

# Locking Wiring Devices



**UPC Code:** 07847798728

**Country of Origin:** United States - \*Eligible for ARRA funded projects

**Configuration:**



**Brand Features**

Leviton's Black & White Midget line of industrial grade locking blade plugs and connectors are feature rugged construction that resists impact, sunlight, chemicals and rough use. All contacts are solid one-piece construction for superior conductivity. The ergonomic, fluted-body design with radial gripping edge is ideal for gripping and pulling. The unique cord clamp accepts a wide range of cord sizes, providing a secure grip without damaging the cord. And, they are backed by a limited lifetime warranty.

**Item Description**

15 Amp, 125 Volt, NEMA ML-1R, 2P, W, Flanged Outlet Locking Receptacle, Industrial Grade, Non-Grounding, MiniLock - WHITE

**Technical Information**

Electrical Specifications

**Grounding:** Non-Grounding

**Amperage:** 15 Amp

**Voltage:** 125 Volt

**NEMA:** ML1R

**Pole:** 2

**Wire:** 2

**Dielectric Voltage:** Withstands 2000V per UL498

**Current Limiting:** Full Rated Current

**Temperature Rise:** Max 30C after 250 cycles OL at 200 percent rated current

Environmental Specifications

**Flammability:** Rated HB or better UL94

**Operating Temperature:** -40C to 60C

Material Specifications

**Face Material:** Nylon

**Body Material:** Impact Modified Nylon

**Line Contacts:** Brass .035 Thick

**Terminal Screws:** Brass 10-32

**Grounding Screw:** Brass 8-32

**Strap Material:** Thermoplastic Nylon

**Color:** White

Mechanical Specifications

**Terminal ID:** Brass-Hot, Green-Ground, White-Neutral

**Terminal ID:** Brass-Hot, Green-Ground, Silver-Neutral

**Terminal Accom.:** 18-14 AWG

**Product ID:** Ratings and NEMA I.D. permanently marked on device

**Termination:** Back

Product Features

**NEMA:** ML-1R

**Color:** White

Standards and Certifications

**NEMA:** WD-6

**ANSI:** C-73

**UL498:** File E13399

**UL Fed Spec WC-596:** File E13399

**CSA C22.2 No. 42:** File LR-406

**NOM:** 057

**Warranty:** Lifetime Warranty

\*May include one or more globally sourced components.



### Dimensional Diagram

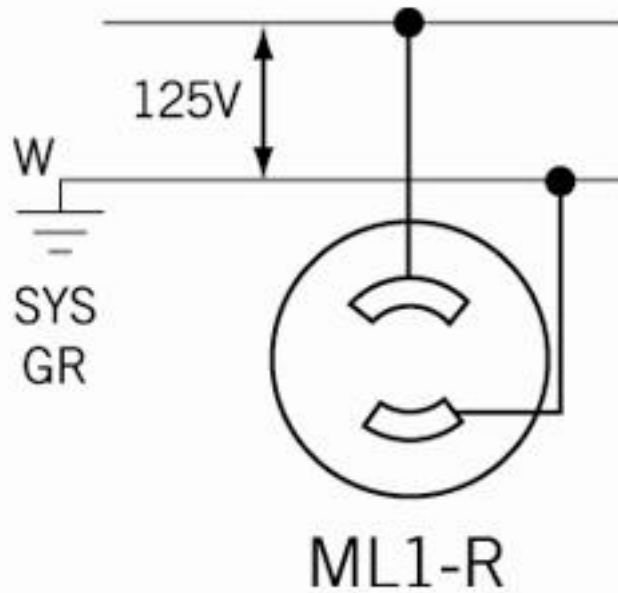
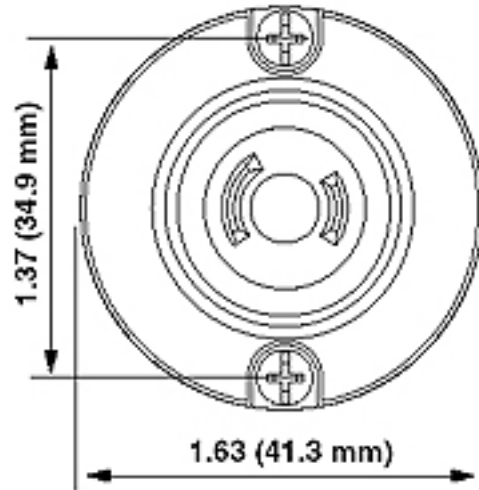

### SPECIFICATION SUBMITTAL

JOB NAME:	CATALOG NUMBERS:	
<input type="text"/>	<input type="text"/>	<input type="text"/>
JOB NUMBER:	<input type="text"/>	<input type="text"/>

**Leviton Manufacturing Co., Inc.**

201 North Service Road, Melville, NY 11747

Telephone: 1-800-323-8920 · FAX: 1-800-832-9538 · Tech Line (8:30AM-7:30PM E.S.T. Monday-Friday): 1-800-824-3005

**Leviton Manufacturing of Canada, Ltd.**

165 Hymus Boulevard, Pointe Claire, Quebec H9R 1E9 · Telephone: 1-800-469-7890 ·

FAX: 1-800-824-3005 · [www.leviton.com/canada](http://www.leviton.com/canada)

**Leviton S. de R.L. de C.V.**

Lago Tana 43, Mexico DF, Mexico CP 11290 · Tel.: (+52)55-5082-1040 · FAX: (+52)5386-1797 · [www.leviton.com.mx](http://www.leviton.com.mx)

**Visit our Website at: [www.leviton.com](http://www.leviton.com)**

© 2012-2016 Leviton Manufacturing Co., Inc. All rights reserved. Subject to change without notice.



**Leviton has a global presence.**

If you would like to know where your local Leviton office is located please go to: [www.leviton.com/international/contacts/](http://www.leviton.com/international/contacts/)

*\*Buy American Compliant Logo -- The American Recovery And Reinvestment Act of 2009 ("ARRA") provides federal grants and loans for projects throughout the country. Section 1605 of the Act, named the "Buy American" provision, requires that certain materials and manufactured products used in projects funded by the Act be manufactured in the United States. The appearance of the Recovery Act Logo in relation to a Leviton product is only intended to reflect that such product may be used in an ARRA funded project. It does not mean that such product or Leviton is sponsored or endorsed by, or that Leviton receives funds from, the federal government or the Recovery Accountability and Transparency Board. Nothing in Leviton's use of the logo is intended to suggest anything regarding the requirements for funding under ARRA.*