

# CS115-2W



UPC Code: 07847781554

Country of Origin: United States - \*Eligible for ARRA funded projects



\*May include one or more globally sourced components.



## Brand Features

Leviton's Commercial Specification Grade switches are designed to offer outstanding reliability and top performance in commercial settings. Ideal applications include municipal facilities, government buildings, malls, department stores, hospital and health care facilities, office buildings, schools, colleges, universities, houses of worship and cultural institutions. Leviton offers a large selection of 15 and 20 Amp Commercial switches, available in a wide variety of colors, wiring options and other features.

## Item Description

15 Amp, 120/277 Volt, Toggle Single-Pole AC Quiet Switch, Commercial Spec Grade, Grounding, Side Wired, - White

## Technical Information

AC Horsepower Ratings

**HP Rating:** 1/2HP-120V 2HP-240V

Electrical Specifications

**Amperage:** 15 Amp

**Voltage:** 120/277 VAC

**Max. Amperage:** 12 Amp

**Dielectric Voltage:** Withstands 1500V for 1 minute

**Temperature Rise:** Maximum 30 degrees C rise

Environmental Specifications

**Flammability:** Rated V-2 per UL94

**Operating Temperature:** -40°C to 65°C

Material Specifications

**Body Material:** Thermoplastic

**Base Material:** PBT

**Strap Material:** Steel

**Actuator Material:** Polycarbonate

**Toggle:** Polycarbonate

**Cover Material:** Nylon

**Contacts:** Silver-Cadmium .031 Thick

**Terminal Screws:** Steel 8-32

**Color:** White

Mechanical Specifications

**Terminal ID:** Brass-Hot, Green-Ground, Silver-Neutral

**Terminal Accom.:** 14-12 AWG

**Termination:** Side

**Product ID:** Stamped on Strap

**Torque Range:** 12-14 inch pounds

Product Features

**Voltage:** 120/277 Volt

**HP Rating:** 1/2HP-120V 2HP-240V-277V

**Actuator Material:** Thermoplastic

**Color:** White

**Warranty:** 10 Year Limited

Standards and Certifications

**NEMA:** WD-1 & WD-6

**ANSI:** C-73

**UL Fed Spec WS896E:** File #E7458

**UL Standard:** UL 20

**CSA C22.2 No. 111:** File #152105

**NOM:** 057

**Warranty:** 10-Year Limited

### Dimensional Diagram

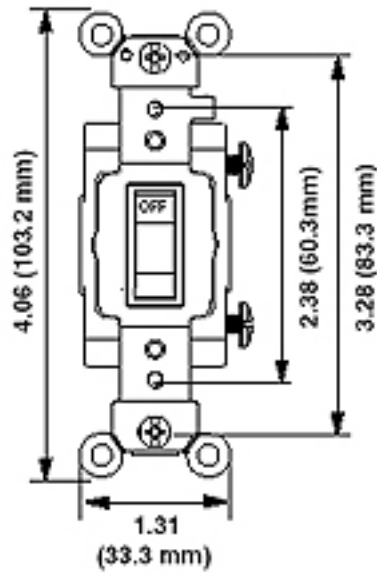

### Wiring Diagram Single Pole

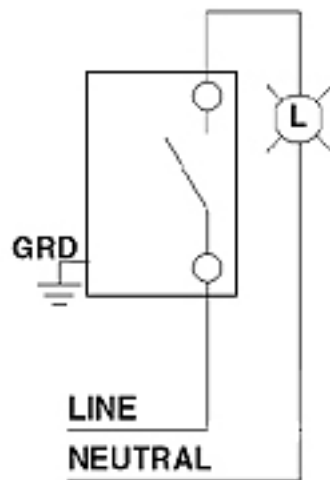

### SPECIFICATION SUBMITTAL

JOB NAME: <input type="text"/>	CATALOG NUMBERS: <input type="text"/>	
JOB NUMBER: <input type="text"/>	<input type="text"/>	<input type="text"/>

**Leviton Manufacturing Co., Inc.**

201 North Service Road, Melville, NY 11747

Telephone: 1-800-323-8920 · FAX: 1-800-832-9538 · Tech Line (8:30AM-7:30PM E.S.T. Monday-Friday): 1-800-824-3005

**Leviton Manufacturing of Canada, Ltd.**

165 Hymus Boulevard, Pointe Claire, Quebec H9R 1E9 · Telephone: 1-800-469-7890 ·

FAX: 1-800-824-3005 · [www.leviton.com/canada](http://www.leviton.com/canada)

**Leviton S. de R.L. de C.V.**

Lago Tana 43, Mexico DF, Mexico CP 11290 · Tel.: (+52)55-5082-1040 · FAX: (+52)5386-1797 · [www.leviton.com.mx](http://www.leviton.com.mx)

**Visit our Website at: [www.leviton.com](http://www.leviton.com)**

© 2012-2016 Leviton Manufacturing Co., Inc. All rights reserved. Subject to change without notice.



**Leviton has a global presence.**

If you would like to know where your local Leviton office is located please go to: [www.leviton.com/international/contacts/](http://www.leviton.com/international/contacts/)

*\*Buy American Compliant Logo -- The American Recovery And Reinvestment Act of 2009 ("ARRA") provides federal grants and loans for projects throughout the country. Section 1605 of the Act, named the "Buy American" provision, requires that certain materials and manufactured products used in projects funded by the Act be manufactured in the United States. The appearance of the Recovery Act Logo in relation to a Leviton product is only intended to reflect that such product may be used in an ARRA funded project. It does not mean that such product or Leviton is sponsored or endorsed by, or that Leviton receives funds from, the federal government or the Recovery Accountability and Transparency Board. Nothing in Leviton's use of the logo is intended to suggest anything regarding the requirements for funding under ARRA.*