

## Brass Ball Valves Series 520

### Advantages

Parker's forged body ball valve provides extended service life and resists failure caused by severe temperature applications. Full flow design assures maximum system efficiency. Highly inert PTFE seats provide resistance to chemical corrosion. Two Viton o-rings at the stem provide maximum safety with no maintenance. The blow-out proof stem, chrome plated brass ball and a specially designed handle enable increased turning leverage for ease of opening and closing. Parker's ball valve can be readily identified, assuring high quality engineering and reliability. This economical ball valve is available in female pipe sizes.

### Applications

Parker's industrial ball valve product line is intended for general purpose use. Please be aware that ball valves are intended for use in the fully open or closed positions. Depending on application conditions, throttling of the valve may result in premature seal failure and/or inability to turn the valve handle.

For use as shutoffs for highway, off highway, and construction equipment vehicles. Water and air service lines on capital equipment and plant design plumbing that require total shutoff capability.

### Working Pressure and Temperature

Saturated steam service up to 150 PSI and 350° F  
Vacuum, 29 Inches of Mercury

### Operating Instructions

Quarter turn is "ON" or "OFF".  
(Provides positive stop action for full shutoff.)

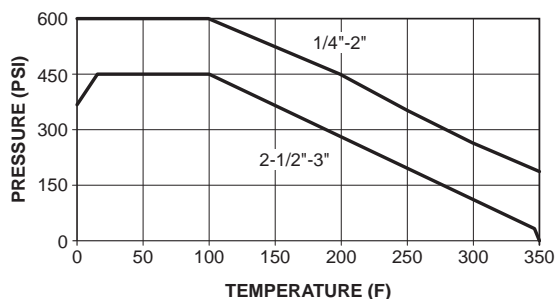

Style	Type	Material	Size	Options
V	520	P	4	00
Style	V – Valve			
Type	520 – Female / Female PTF Ports			
Material	P – Brass			
Size	4 - 1/4"			
	6 - 3/8"			
	8 - 1/2"			
	12 - 3/4"			
	16 - 1"			
	20 - 1-1/4"			
	24 - 1-1/2"			
32 - 2"				

### U.L. Listed

U.L. Category	Description
YSDT	LP-Gas Shut-off Valves
YRBX	Flammable Liquid Shut-off Valves
YRPV	Gas Shut-off Valves
YQNZ	Compressed Gas Shut-off Valves

**Brass Ball Valve V520P**

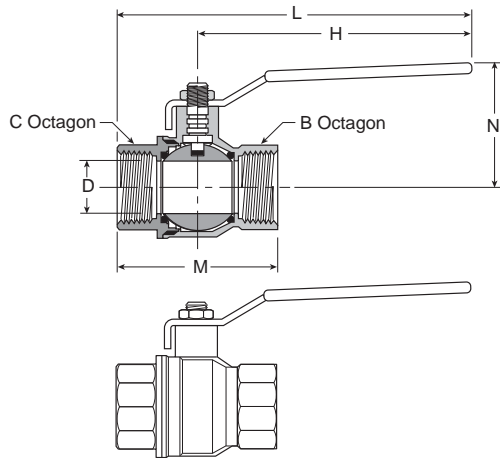

Part No.	Pipe Thread	B Octagon	C Octagon	H	L	M	N	Flow Dia. D
V520P-4	1/4-18	.79	.79	3.94	4.83	1.77	1.50	.310
V520P-6	3/8-18	.79	.79	3.94	4.83	1.77	1.50	.400
V520P-8	1/2-14	.98	.98	3.94	5.10	2.32	1.69	.600
V520P-12	3/4-14	1.22	1.22	4.72	5.98	2.52	1.97	.790
V520P-16	1-11.5	1.57	1.57	4.72	6.32	3.19	2.13	1.000
V520P-20	1-1/4	1.93	1.93	6.22	8.05	3.66	2.82	1.250
V520P-24	1-1/2	2.13	2.13	6.22	8.23	4.02	3.06	1.570
V520P-32	2	2.69	2.69	6.22	8.58	4.76	3.33	2.000
V520P-40	2-1/2	3.35	3.35	10.04	13.11	6.14	5.20	2.520
V520P-48	3	3.89	3.89	10.04	13.52	6.97	5.51	3.000

