

## Triple-Lok

Parker Triple-Lok fittings meet the strict requirements of SAE J514 and ISO 8434-2 industry standards for 37° flare fittings. Its design is simple. It uses an easily produced flare at the tube end to seal and hold fluid under high pressure. The fitting consists of three pieces: the body, sleeve and nut. The tube is flared at a 37° angle (74° included angle) and held between the fitting nose (seat) and the sleeve (support) with the nut as shown in Fig. B1, providing a very effective seal between the fitting nose and the tube flare.

The design of Triple-Lok fittings is very efficient. The fitting incorporates the smallest seal area of all fitting types. This seal area, as seen in Fig. B1, is only slightly larger than the fluid flow area. The small seal area results in a compact design, low assembly torque, and a relatively high-pressure capability.

## How Triple-Lok Fittings Work

Tightening of the nut clamps the tube flare between the body nose (seat) producing a leak tight connection. This clamping on the 37° taper provides a measure of elasticity to the joint helping it to resist loosening under vibration. The clamping force results in a small radial load that tends to deform the fitting nose radially. The resistance of the nose to elastic deformation provides a constant preload (similar to a lockwasher) keeping it tight.

The clamping force provided by the nut resists the opposing force of the fluid under pressure. The joint remains leak tight as long as the clamping force is higher than the opposing pressure load. Properly assembled Triple-Lok fittings with appropriate tube will seal consistently under pressure until tube bursts.

Sealing in Triple-Lok fittings takes place between two smooth metal surfaces, the fitting nose and inside of the tube flare. Therefore, the sealing surfaces have to be smooth, free of any nicks, scratches, spiral tool marks, splits or weld beads. Seamless or welded and drawn fully annealed tube is recommended for Triple-Lok fittings for ease in flaring and bending. Certain types of harder tubes that are not fully annealed may not be suitable for flaring due to the potential for immediate or long-term cracking of the tube flare. For specific tube type and wall thickness recommendations, please see Table U3 in the Appendix Section.

## International Acceptance

The versatility of 37° flare fittings is a primary reason for its worldwide acceptance. To illustrate the versatility of Triple-Lok, refer to Fig. B2. The Triple-Lok adapter is attachable to either inch tube, metric tube, or a hose assembly. To adapt to metric tube, simply change the sleeve (using the standard inch adapter and nut). Please see Table U4 in the Appendix Section for a clear illustration of every "convertible sleeve" connection for the 37° design. For example, for a 25 mm tube assembly, a standard SAE -16 (1") flare fitting and nut would be used, however, a 25 mm metric sleeve (TXS25) would replace the inch size sleeve.

Triple-Lok fittings are available with many different port options for the various international hydraulic ports available, such as SAE straight thread, NPT/NPTF, BSPP, BSPT and Metric (including ISO 6149).

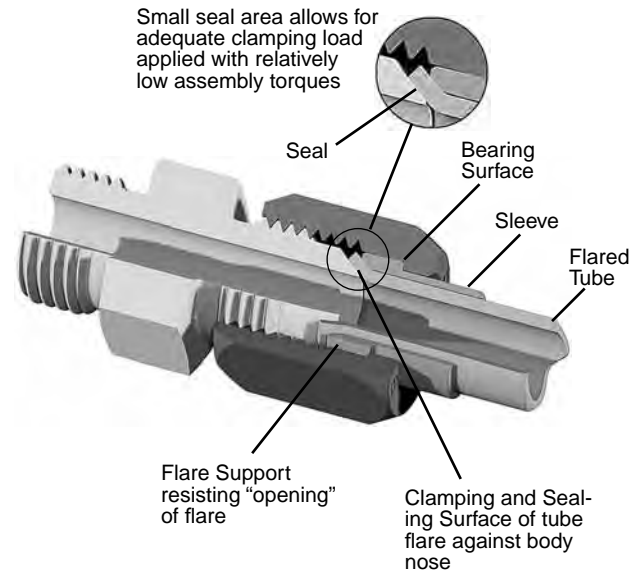

Fig. B1 – Triple-Lok Design and Features

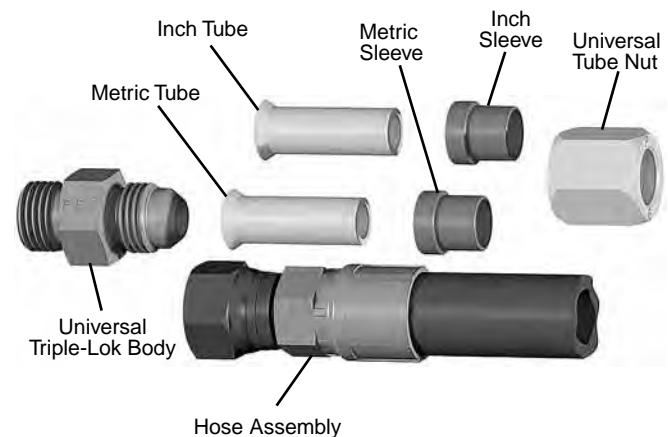

Fig. B2 – Triple-Lok's Adaptability to Inch Tube, Metric Tube, or Hose Assemblies

## Triple-Lok 2

Triple-Lok 2 combines the versatility of stainless steel Triple-Lok with the added advantage of an elastomeric seal. It incorporates an O-ring that is positioned in the nose of the 37° flare so that elastomeric sealing occurs with the mating flared tube. Similar to the standard stainless steel Triple-Lok, Triple-Lok 2 consists of three pieces: the body (with O-ring), the standard Triple-Lok sleeve and standard Triple-Lok nut. The tube end is flared at a 37° angle (74° included angle) and held between the fitting nose and sleeve with the nut as shown in Fig. B3, providing a very effective elastomeric seal between the fitting nose and the tube flare.

## The Parker Advantage

**Robust Port Stud:** The adjustable port stud is manufactured with a longer locknut designed to cover the uppermost threads completely. Since the backup washer is never exposed to the upper threads, it cannot be damaged during assembly. During assembly, exposed upper threads, as common with fittings from other fitting manufacturers, can lead to a deformed backup washer that can pinch the o-ring and create an o-ring extrusion gap that has the potential to leak. The longer locknut also provides a greater grip area for the wrench.

**Superior Plating:** Superior plating gives Parker steel tube fittings unmatched protection against red rust. In neutral salt spray test per ASTM B117, Parker Triple-Lok fittings substantially exceeded the SAE requirement of 96 hours to red rust.

**Pre-Lubricated Stainless Steel Tube Nut:** All stainless steel Triple-Lok tube nuts have a pre-applied anti-seize lubricant to prevent galling during assembly.

**Triple-Lok 2:** Triple-Lok 2 utilizes an elastomeric seal in the flare nose for improved seal reliability in applications where stainless steel fittings are required.

**Wide Selection:** Triple-Lok fittings are available as standard in steel, stainless steel, brass and aluminum materials. Coupled with its broad line of configurations and port end options, Parker is well positioned to better service the hydraulic requirements of the international markets.

## Reference locations

**Dynamic Pressure Ratings:** Please refer to the last column of the part number tables located on the following pages of this section for the appropriate dynamic pressure ratings.

**Recommended Tube Wall Thickness:** Please refer to Table U3 located in the Appendix section.

**Assembly and Installation:** Please refer to Triple-Lok Assembly located within the Assembly/Installation section of this catalog.

**Standard material specifications:** Please refer to Table U1 located in the Appendix section.

**Seal Material Selection:** Please refer to Table T8 in the General Technical section of this catalog.

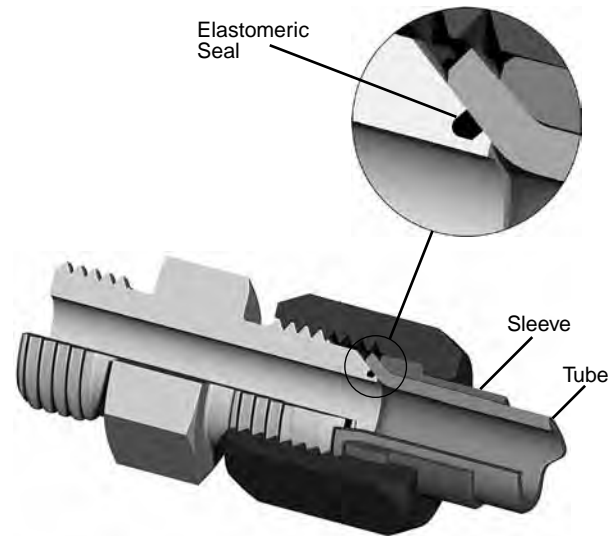

Fig. B3 – Triple-Lok 2 Design and Features

Dimensions and pressures for reference only, subject to change.

### F50X

Straight Thread Connector  
37° Flare / SAE-ORB

SAE 070120  
HPD Base # 0503

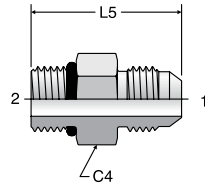

### FF50X

Long Straight Thread Connector  
37° Flare / SAE-ORB

SAE 071720  
HPD Base # 053E

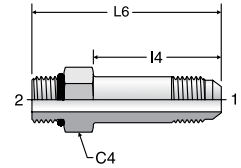

TUBE FITTING PART #	END SIZE		C4 HEX (in.)	L5 (in.)	Dynamic Pressure (x 1,000 PSI)			
	1 (in.)	2 UN/UNF-2A			-S	-SS	-B	D
2 F50X	1/8	5/16 - 24	7/16	1.06	7.5	9.0	3.3	3.8
3 F50X	3/16	3/8 - 24	1/2	1.10	7.5	9.0	3.3	3.8
3-2 F50X	3/16	5/16 - 24	1/2	1.10	7.5	9.0	3.3	3.8
4 F50X	1/4	7/16 - 20	9/16	1.23	7.5	9.0	3.3	3.8
4-2 F50X	1/4	5/16 - 24	9/16	1.17	7.5	9.0	3.3	3.8
4-3 F50X	1/4	3/8 - 24	9/16	1.19	7.5	9.0	3.3	3.8
4-5 F50X	1/4	1/2 - 20	5/8	1.23	6.0	7.2	3.3	3.0
4-6 F50X	1/4	9/16 - 18	11/16	1.29	6.0	7.2	3.3	3.0
4-8 F50X	1/4	3/4 - 16	7/8	1.38	6.0	7.2	3.3	3.0
4-10 F50X	1/4	7/8 - 14	1	1.49	5.0	6.0	3.3	2.5
5 F50X	5/16	1/2 - 20	5/8	1.23	6.0	7.2	3.3	3.0
5-4 F50X	5/16	7/16 - 20	9/16	1.23	6.0	7.2	3.3	3.0
5-6 F50X	5/16	9/16 - 18	11/16	1.30	6.0	7.2	3.3	3.0
5-8 F50X	5/16	3/4 - 16	7/8	1.37	6.0	7.2	3.3	3.0
6 F50X	3/8	9/16 - 18	11/16	1.30	6.0	7.2	3.3	3.0
6-4 F50X	3/8	7/16 - 20	5/8	1.27	6.0	7.2	3.3	3.0
6-5 F50X	3/8	1/2 - 20	5/8	1.27	6.0	7.2	3.3	3.0
6-8 F50X	3/8	3/4 - 16	7/8	1.38	6.0	7.2	3.3	3.0
6-10 F50X	3/8	7/8 - 14	1	1.50	5.0	6.0	3.3	2.5
6-12 F50X	3/8	1 1/16 - 12	1 1/4	1.66	5.0	6.0	3.3	2.5
8 F50X	1/2	3/4 - 16	7/8	1.48	6.0	7.2	3.3	3.0
8-4 F50X	1/2	7/16 - 20	13/16	1.50	6.0	7.2	3.3	3.0
8-6 F50X	1/2	9/16 - 18	13/16	1.44	6.0	7.2	3.3	3.0
8-10 F50X	1/2	7/8 - 14	1.00	1.60	5.0	6.0	3.3	2.5
8-12 F50X	1/2	1 1/16 - 12	1 1/4	1.76	5.0	6.0	3.3	2.5
8-16 F50X	1/2	1 5/16 - 12	1 1/2	1.78	4.5	5.4	2.9	2.3
10 F50X	5/8	7/8 - 14	1	1.70	5.0	6.0	3.3	2.5
10-6 F50X	5/8	9/16 - 18	11/16	1.71	5.0	6.0	3.3	2.5
10-8 F50X	5/8	3/4 - 16	15/16	1.64	5.0	6.0	3.3	2.5
10-12 F50X	5/8	1 1/16 - 12	1 1/4	1.86	5.0	6.0	3.3	2.5
10-16 F50X	5/8	1 5/16 - 12	1 1/2	1.89	4.5	5.4	2.9	2.5
12 F50X	3/4	1 1/16 - 12	1 1/4	1.97	5.0	6.0	3.3	2.5
12-8 F50X	3/4	3/4 - 16	1 1/8	1.94	5.0	6.0	3.3	2.5
12-10 F50X	3/4	7/8 - 14	1 1/8	1.88	5.0	6.0	3.3	2.5
12-14 F50X	3/4	1 3/16 - 12	1 3/8	1.96	5.0	6.0	3.3	2.5
12-16 F50X	3/4	1 5/16 - 12	1 1/2	1.99	4.5	5.4	2.9	2.3
12-20 F50X	3/4	1 5/8 - 12	1 7/8	2.08	4.0	4.8	2.6	•
14 F50X	7/8	1 3/16 - 12	1 3/8	1.99	5.0	6.0	3.3	2.5
14-16 F50X	7/8	1 5/16 - 12	1 1/2	2.02	4.5	5.4	2.9	2.3
16 F50X	1	1 5/16 - 12	1 1/2	2.04	4.5	5.4	2.9	2.3
16-8 F50X	1	3/4 - 16	1 3/8	1.78	4.5	5.4	2.9	2.3
16-10 F50X	1	7/8 - 14	1 3/8	2.08	4.5	5.4	2.9	2.3
16-12 F50X	1	1 1/16 - 12	1 3/8	1.99	4.5	5.4	2.9	2.3
16-14 F50X	1	1 3/16 - 12	1 3/8	2.05	4.5	5.4	2.9	2.3
16-20 F50X	1	1 5/8 - 12	1 7/8	2.12	4.0	4.8	2.6	•
16-24 F50X	1	1 7/8 - 12	2 1/8	2.20	3.0	3.6	2.0	•
20 F50X	1 1/4	1 5/8 - 12	1 7/8	2.17	4.0	4.8	2.6	•
20-12 F50X	1 1/4	1 1/16 - 12	1 11/16	2.30	4.0	4.8	2.6	•
20-16 F50X	1 1/4	1 5/16 - 12	1 11/16	2.33	4.0	4.8	2.6	•
20-24 F50X	1 1/4	1 7/8 - 12	2 1/8	2.24	3.0	3.6	2.0	•
24 F50X	1 1/2	1 7/8 - 12	2 1/8	2.38	3.0	3.6	2.0	•
24-20 F50X	1 1/2	1 5/8 - 12	2	2.53	3.0	3.6	2.0	•
24-32 F50X	1 1/2	2 1/2 - 12	2 3/4	2.53	2.0	2.4	1.3	•
32 F50X	2	2 1/2 - 12	2 3/4	2.78	2.0	2.4	1.3	•
32-24 F50X	2	1 7/8 - 12	2 5/8	2.94	2.0	2.4	1.3	•

TUBE FITTING PART #	END SIZE		C4 HEX (in.)	I4 (in.)	L6 (in.)	Dynamic Pressure (x 1,000 PSI)		
	1 (in.)	2 UN/UNF-2A				-S	-SS	-B
4 FF50X	1/4	7/16 - 20	9/16	1.39	2.08	7.5	9.0	3.3
4-6 FF50X	1/4	9/16 - 18	11/16	1.38	2.13	6.0	7.2	3.3
6 FF50X	3/8	9/16 - 18	11/16	1.56	2.31	6.0	7.2	3.3
8 FF50X	1/2	3/4 - 16	7/8	1.88	2.70	6.0	7.2	3.3
10 FF50X	5/8	7/8 - 14	1	2.09	3.04	5.0	6.0	3.3
12 FF50X	3/4	1 1/16 - 12	1 1/4	2.50	3.61	5.0	6.0	3.3
16 FF50X	1	1 5/16 - 12	1 1/2	2.84	3.98	4.5	5.4	2.9
20 FF50X	1 1/4	1 5/8 - 12	1 7/8	3.47	4.69	4.0	4.8	2.6

### XHB3

Braze Socket  
37° Flare / Inch Tube Braze

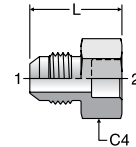

TUBE FITTING PART #	END SIZE		C4 HEX (in.)	L (in.)	Dynamic Pressure (x 1,000 PSI)		
	1 (in.)	2 (in.)			-S	-SS	-B
4 XHB3	1/4	1/4	9/16	0.97	7.5	7.5	3.3
6 XHB3	3/8	3/8	5/8	1.00	6.0	6.0	3.3
6-4 XHB3	3/8	1/4	5/8	1.00	6.0	6.0	3.3
6-8 XHB3	3/8	1/2	5/8	1.00	6.0	6.0	3.3
8 XHB3	1/2	1/2	13/16	1.12	6.0	6.0	3.3
8-10 XHB3	1/2	5/8	13/16	1.12	5.0	5.0	3.3
10 XHB3	5/8	5/8	15/16	1.21	5.0	5.0	3.3
10-8 XHB3	5/8	1/2	15/16	1.21	5.0	5.0	3.3
10-12 XHB3	5/8	3/4	1 1/8	1.37	5.0	5.0	3.3
12 XHB3	3/4	3/4	1 1/4	1.51	5.0	5.0	3.3
12-10 XHB3	3/4	5/8	1 1/8	1.51	5.0	5.0	3.3
12-16 XHB3	3/4	1	1 1/4	1.57	4.0	4.0	2.6
16 XHB3	1	1	1 3/8	1.63	4.0	4.0	2.6
16-20 XHB3	1	1 1/4	1 11/16	1.73	4.0	4.0	2.6
20 XHB3	1 1/4	1 1/4	1 11/16	1.71	4.0	4.0	2.6
20-24 XHB3	1 1/4	1 1/2	2	1.71	3.0	3.0	2.0
24 XHB3	1 1/2	1 1/2	2	1.84	3.0	3.0	2.0
32 XHB3	2	2	2 5/8	2.16	2.0	2.0	1.3

Note: Braze rings are on page B10.

Dimensions and pressures for reference only, subject to change.