



# SERVICE PARTS LIST

**BULLETIN NO.**  
**54-49-8400**

SPECIFY CATALOG NO. AND SERIAL NO. WHEN ORDERING PARTS		REVISED BULLETIN	DATE
<b>PACKOUT™ Rolling Tool Box Assembly</b>			Jan. 2019
CATALOG NO. <b>48-22-8426</b>	SERIAL NUMBER	WIRING INSTRUCTION	

48-22-8426 Includes:

48-22-8425	PACKOUT™ Large Tool Box Assembly	Page 3
48-22-8424	PACKOUT™ Medium Tool Box Assembly	Page 3
48-22-8430	PACKOUT™ Organizer Assembly	Page 4
48-22-8435	PACKOUT™ Compact Organizer Assembly	Page 4
48-22-8310	PACKOUT™ Small 10" Storage Tote	Page 5
48-22-8315	PACKOUT™ Medium 15" Storage Tote	Page 5
48-22-8320	PACKOUT™ Large 20" Storage Tote	Page 5

**EXAMPLE:**  
Component Parts (Small #) Are Included When Ordering The Assembly (Large #).

\*See page 6 thru 9 for Additional Storage Products:

48-22-8431	PACKOUT™ S-Organizer Assembly	Page 6
48-22-8436	PACKOUT™ S-Organizer Compact Assembly	Page 6
48-22-8450	PACKOUT™ Tool Box Assembly	Page 7
48-22-8321	PACKOUT™ Medium 15" Tool Bag	Page 8
48-22-8322	PACKOUT™ Large 20" Tool Bag	Page 8
48-22-8300	PACKOUT™ Tech Bag	Page 9
48-22-8301	PACKOUT™ Jobsite Backpack	Page 9
48-22-8302	PACKOUT™ Jobsite Cooler	Page 9

FIG.	PART NO.	DESCRIPTION OF PART	NO. REQ.
1	43-62-8400T	Retractable Handle Grip Service Kit	(1)
2	-----	Screw	(2)
3	43-62-8400	Retractable Handle Service Assembly	(1)
4	-----	Screw	(2)
5	43-62-8426	Side Handle Service Kit (Contains 2 Side Handles and 4 Pins)	(1)
6	-----	Pin	(4)
7	45-94-8426	Wheel Service Kit (Contains 2 Wheels and 2 Locking Hex Nuts)	(1)
8	-----	Locking Hex Nut	(2)
9	44-20-8400	Latch Service Assembly (Set of 2)	(1)
10	31-01-8400	Storage Tray	(1)
11	43-44-8400	Lid Gasket (Not Shown)	(1)
12	42-12-8426	Axle Service Kit (Contains 1 Axle and 2 Locking Hex Nuts)	(1)

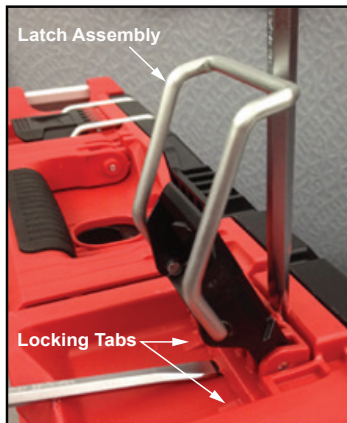

As an aid to removing a damaged Latch Assembly (9), use two large flat blade screwdrivers. Push blades between parts as shown. Twist both screwdrivers at same time to force the blades into opening and work the latch assembly over the two locking tabs.

To install a new latch assembly, position entire latch assembly over locking tabs with the two top lugs partially inserted in 'catch cavity' of main housing. Engage latch bar onto lid and gently press latch lever to slide assembly over two locking tabs and into place.

This removal and installation process will be the same where other service latches are offered in this system.

**MILWAUKEE TOOL • www.milwaukeetool.com**  
13135 W. LISBON RD., BROOKFIELD, WI 53005  
Drwg. 4

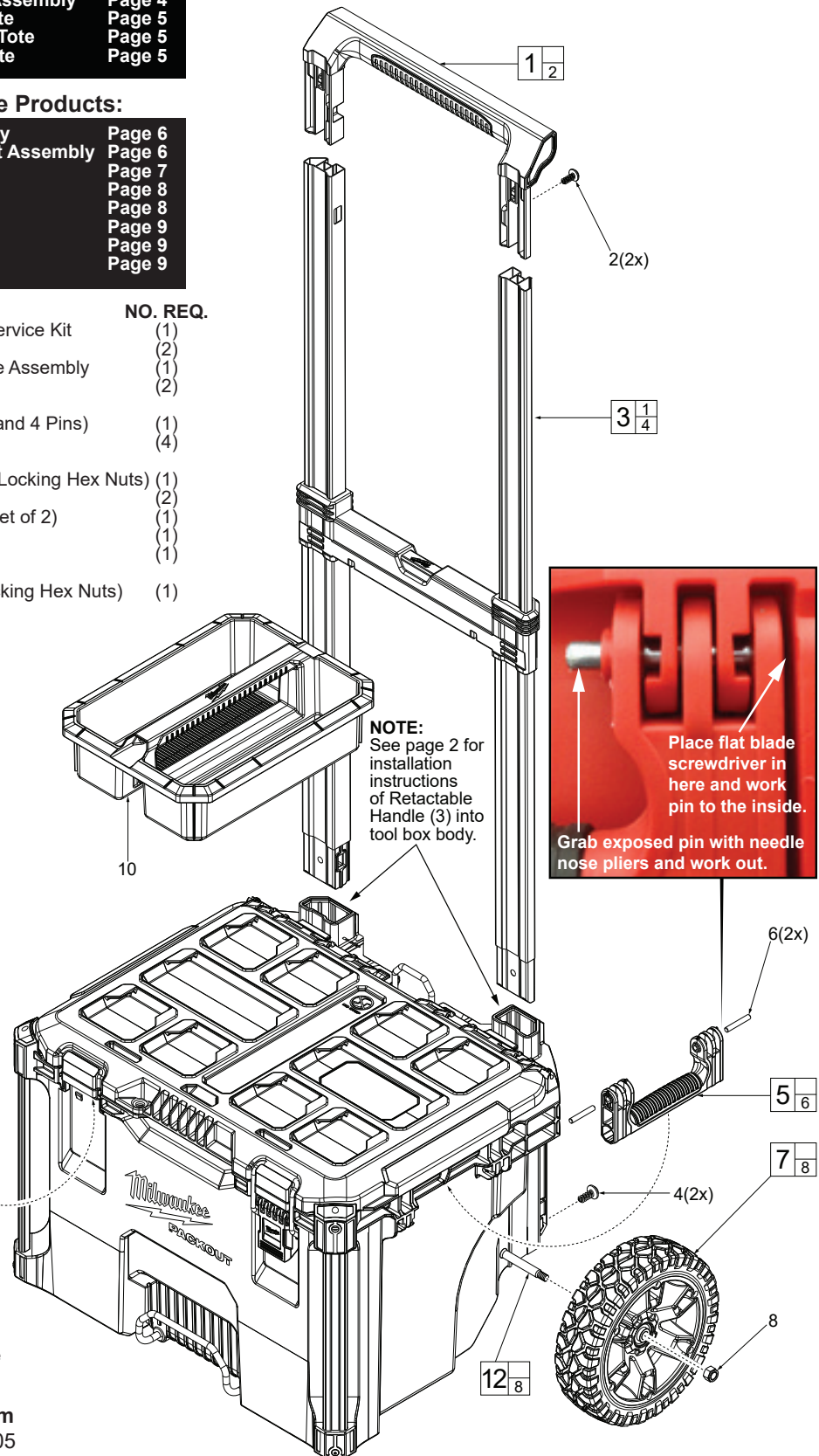



Extend Retractable Handle Assembly (3) beyond bottom opening in tool box to see the holes that must line up prior to securing with screws (4).

Push assembly back into channel so bottom of handle section shown is flush with bottom of channel. This should be very close to aligning the holes. To be sure, a thin pick can be used in hole to make adjustments.

Push this area into channel so bottom is flush to bottom of box

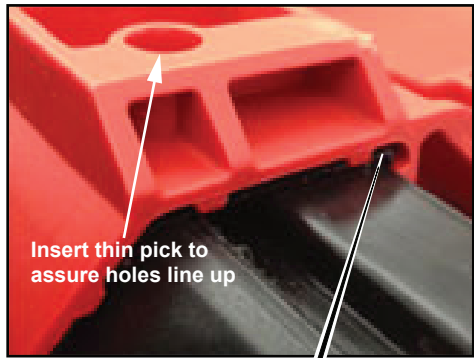

Insert thin pick to assure holes line up



Both surfaces to be flush

As an aid to installation, collapse the Retractable Handle Assembly (3).

Properly orient the assembly and insert both sides into tool box channels.

Holes of Retractable Handle Assembly (3) must line up with holes on the back of tool box body prior to securing with screws (4).

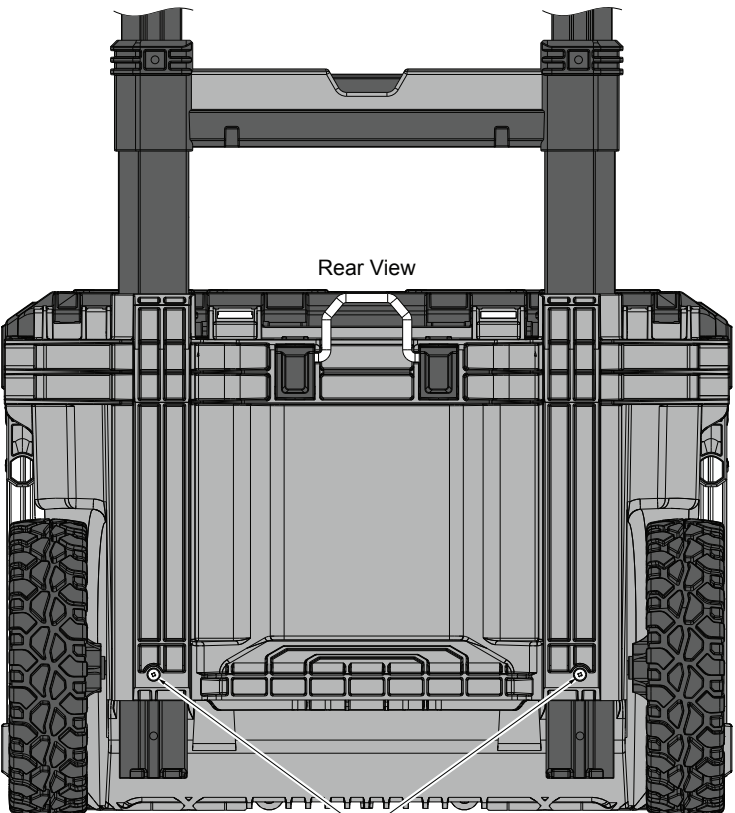

Rear View

Screws (4)

### 48-22-8425 PACKOUT™ (Large) Tool Box

FIG.	PART NO.	DESCRIPTION OF PART	NO. REQ.
1	43-62-8425	Top Handle Service Kit	(1)
2	-----	Pin	(2)
3	43-62-8424	Side Handle Service Kit	(1)
4	-----	Pin	(2)
5	44-20-8400	Latch Service Assembly (Set of 2)	(1)
6	31-01-8400	Storage Tray	(1)
7	43-44-8400	Lid Gasket (Not Shown)	(1)

Pins to be installed from the inside of the handle.

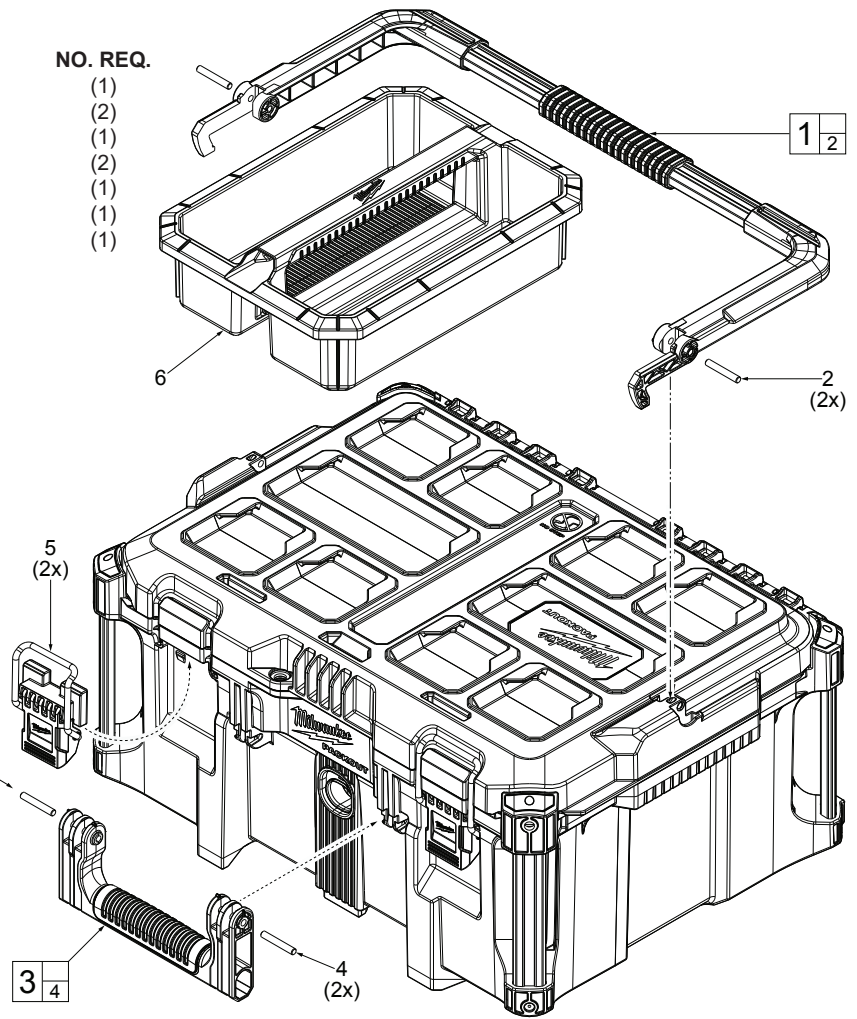

### 48-22-8424 PACKOUT™ (Medium) Tool Box

FIG.	PART NO.	DESCRIPTION OF PART	NO. REQ.
3	43-62-8424	Side Handle Service Kit	(1)
4	-----	Pin	(2)
5	44-20-8400	Latch Service Assembly (Set of 2)	(1)
7	43-44-8400	Lid Gasket (Not Shown)	(1)
8	31-01-8424	Storage Bin Kit (Set of 4)	(1)
8a	-----	Deep Bin with Two Dividers	(2)
8b	-----	Shallow Bin	(1)
8c	-----	Shallow Bin with Cover	(1)

Pins to be installed from the inside of the handle.

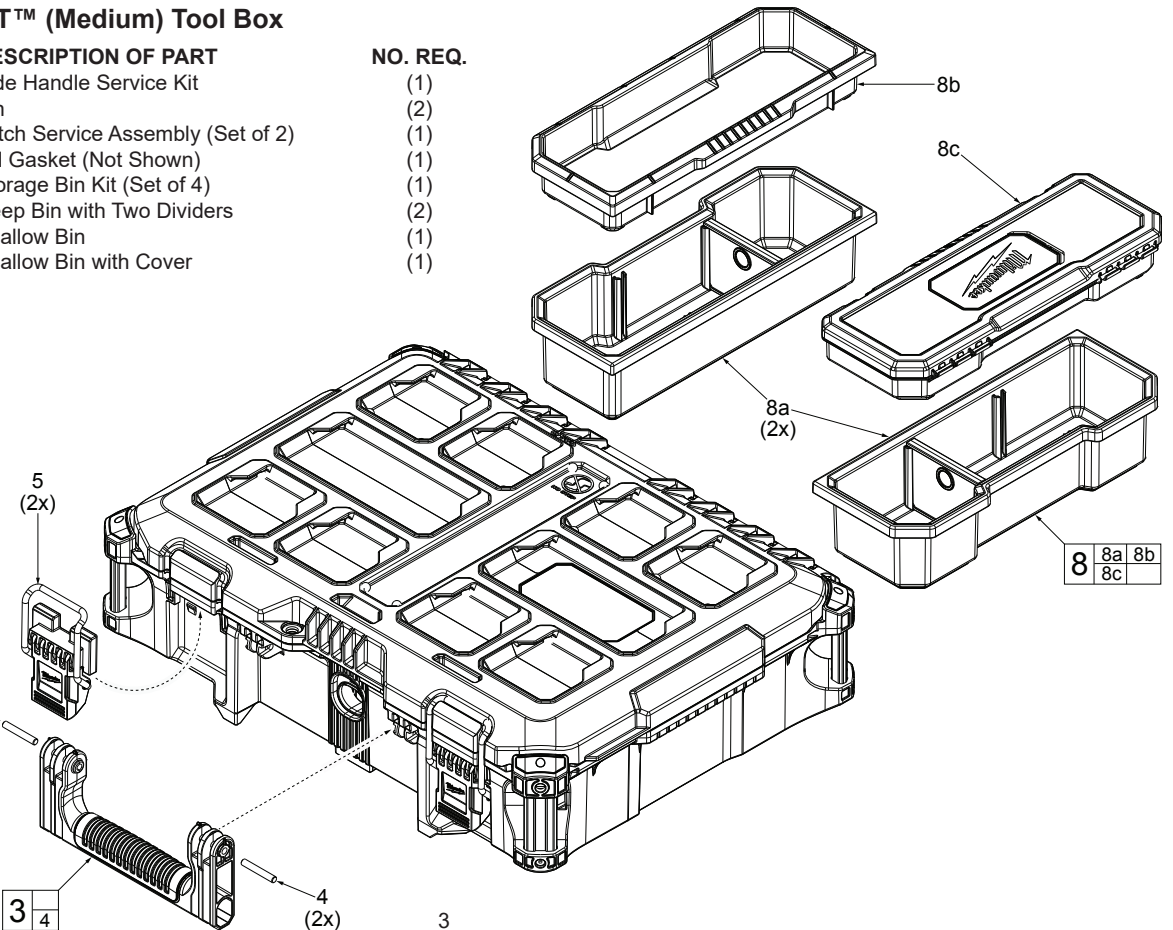

### 48-22-8430 PACKOUT™ Organizer

FIG.	PART NO.	DESCRIPTION OF PART	NO. REQ.
3	43-62-8430	Side Handle Service Kit	(1)
4	-----	Pin	(2)
5	44-20-8430	Latch Service Assembly (Set of 2)	(1)
7	43-44-8430	Lid Gasket (Not Shown)	(1)
9	31-01-0501	5 Bin Kit (Set of 1)	(2)
9a	-----	Large Bin	(1)
9b	-----	Small Bin	(4)

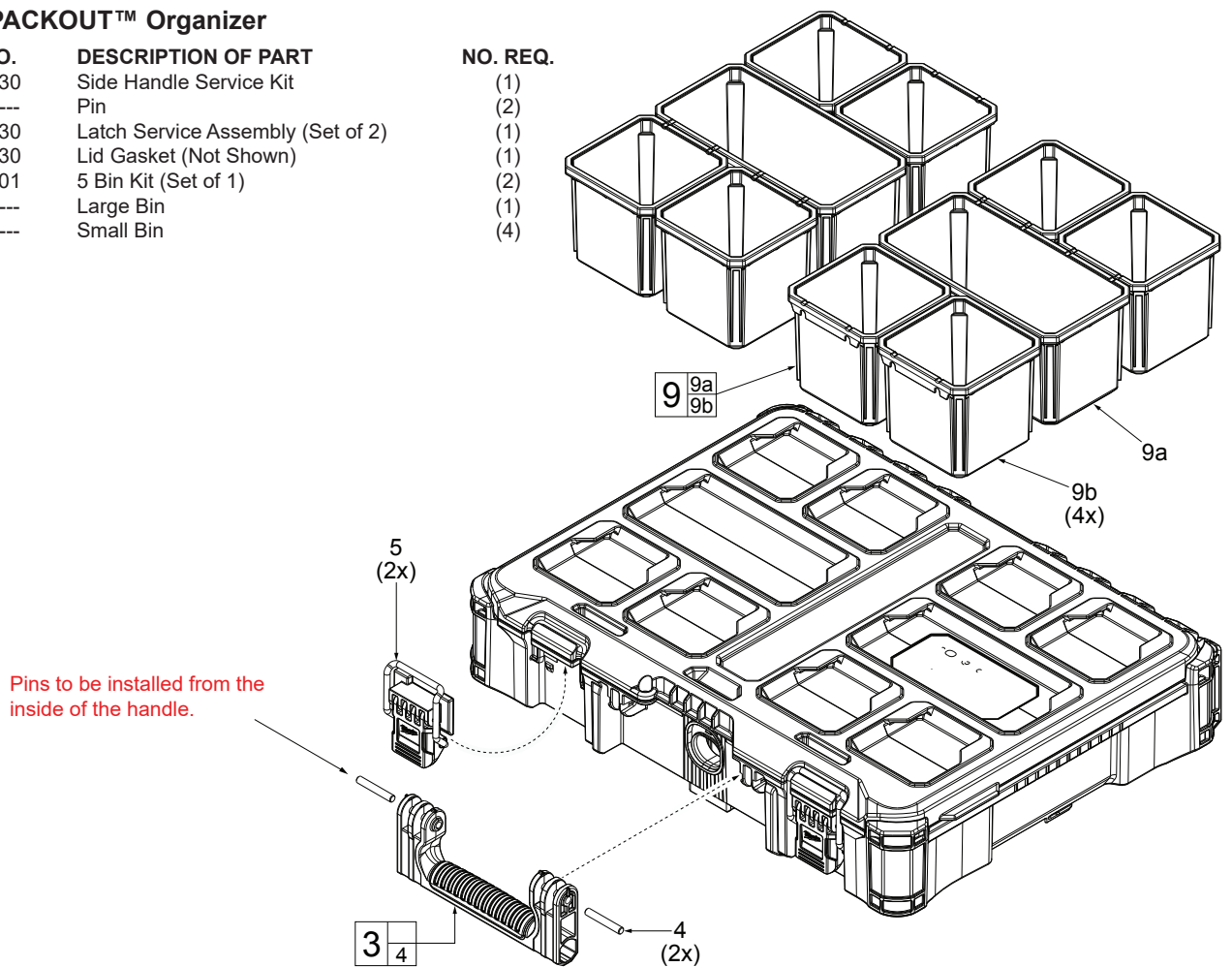

### 48-22-8435 PACKOUT™ Compact Organizer

FIG.	PART NO.	DESCRIPTION OF PART	NO. REQ.
3	43-62-8435	Side Handle Service Kit	(1)
4	-----	Pin	(2)
7	43-44-8435	Lid Gasket (Not Shown)	(1)
9	31-01-0501	5 Bin Kit	(1)
9a	-----	Large Bin	(1)
9b	-----	Small Bin	(4)

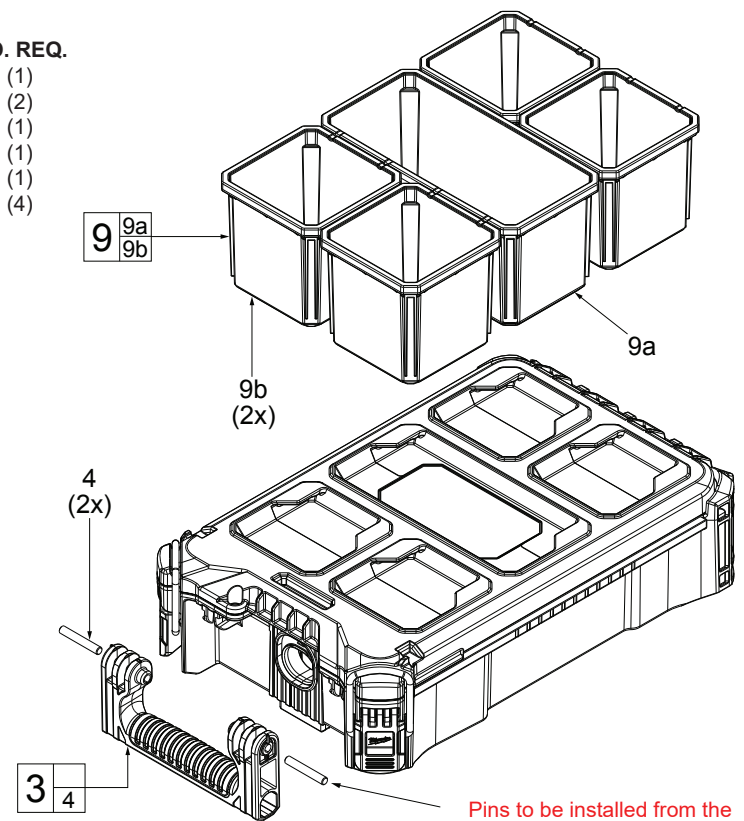

- 48-22-8310 10" PACKOUT™(Small) Storage Tote
- 48-22-8315 15" PACKOUT™ (Medium) Storage Tote
- 48-22-8320 20" PACKOUT™ (Large) Storage Tote



FIG.	PART NO.	DESCRIPTION OF PART	NO. REQ.
1	45-56-8300	Shoulder Strap (For all three tote models)	(1)
2	44-20-8300	Locker Kit (For all three tote models)	(1)
	or		
3	44-20-0305	Locker Kit (For all three tote models)	(1)



**SEE DIAGRAMS BELOW TO DETERMINE LOCKER SERVICE PART NEEDED.**



To remove a damaged locker system, flip tote upside down and approach tote from the bottom of base. Insert a large flat blade screwdriver in middle of locking carriage as shown. Lightly pry carriage upward out of base opening. Remove and discard old locking carriage and spring.

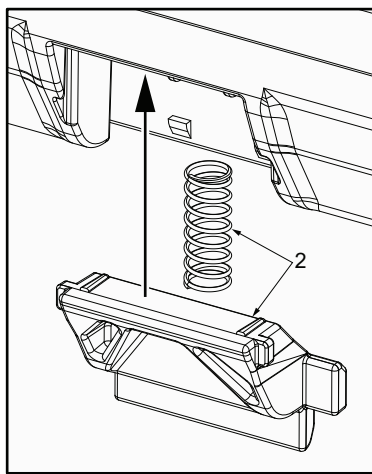

**No. 44-20-8300**  
Locker Kit  
For early production PACKOUT™  
Storage Totes

To install a Locker Kit (2), align spring as shown and guide the tabs of locking carriage in channels of tote base. Push locking carriage upward to snap into place.

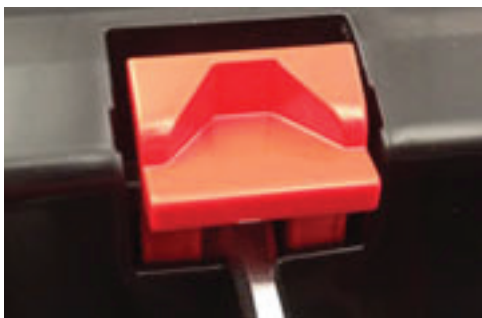

To remove a damaged locker system, flip tote over on the side and approach tote from the bottom of base. Insert a large flat blade screwdriver in middle of locking carriage as shown. Lightly pry carriage upward out of base opening. Remove and discard old locking carriage.

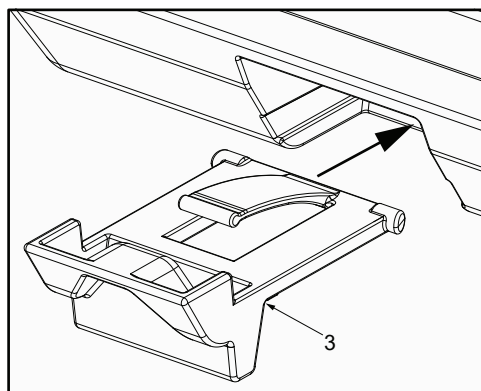

**No. 44-20-0305**  
Locker  
For later production PACKOUT™  
Storage Totes

To install a new Locker (3), guide the tabs of locking carriage in channels of tote base. Push locking carriage forward to snap into place.



**48-22-8431 PACKOUT™ S-Organizer Assembly**

FIG.	PART NO.	DESCRIPTION OF PART	NO. REQ.
1	44-20-8431	LP Organizer Latch (Set of 2)	(1)
2	31-01-0502	5 PC Bin S-Organizer with 6 Dividers	(2)
3	43-44-8430	Lid Gasket (Not Shown)	(1)

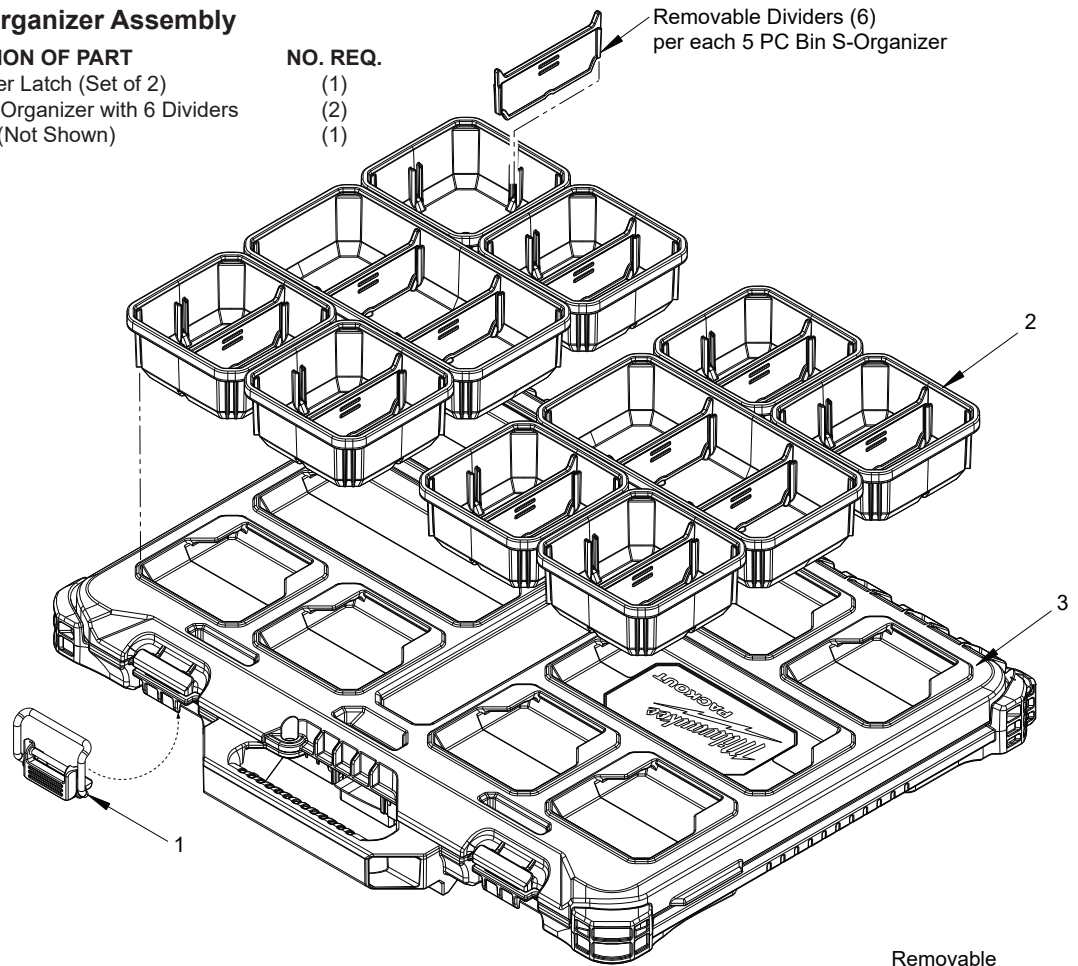

**48-22-8436 PACKOUT™ S-Organizer Compact Assembly**

FIG.	PART NO.	DESCRIPTION OF PART	NO. REQ.
1	44-20-8436	LP Compact Org Latch (Set of 2)	(1)
2	31-01-0502	5 PC Bin S-Organizer with 6 Dividers	(1)
3	43-44-8435	Lid Gasket (Not Shown)	(1)

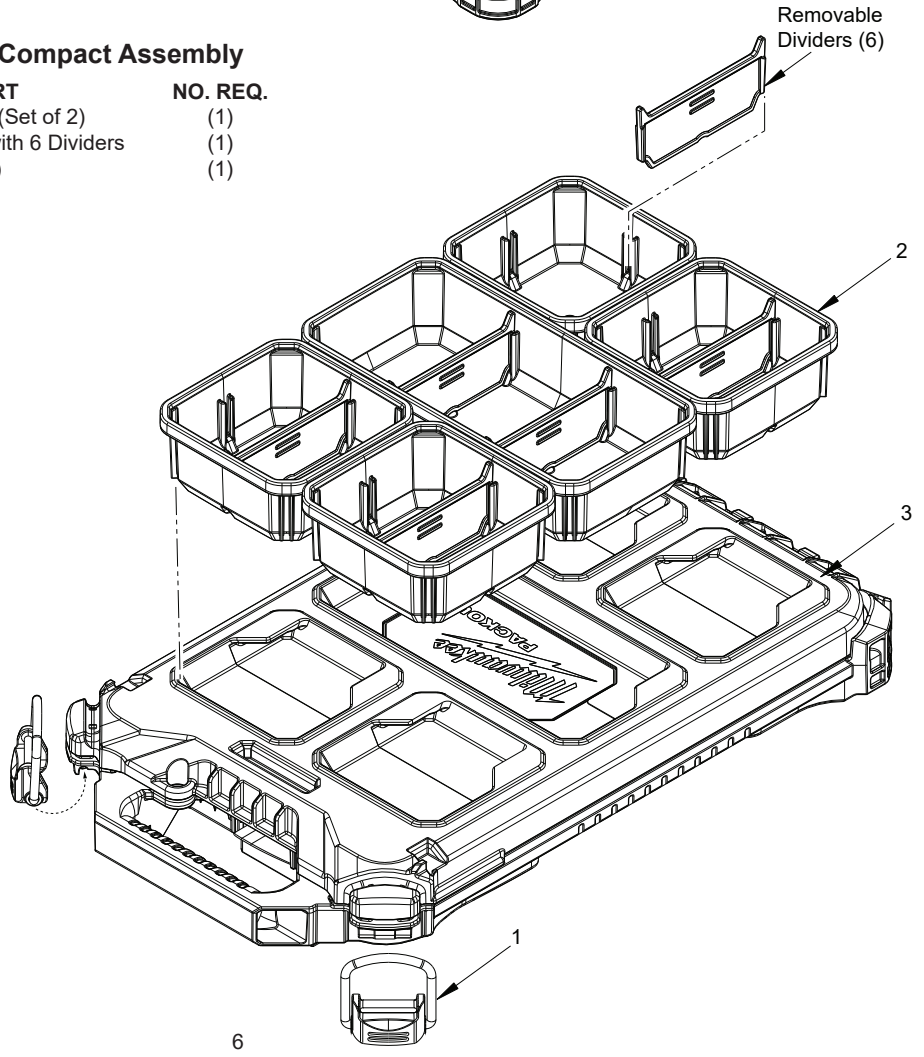

**48-22-8450 PACKOUT™ Tool Box Kit with Foam Dividers**

FIG.	PART NO.	DESCRIPTION OF PART	NO. REQ.
1	43-62-8450	Kit Box Mono Block Handle with 2 Pins	(1)
2	44-20-8430	Latch Service Assembly (Set of 2)	(2)
3	43-44-8400	Lid Gasket (Not Shown)	(1)
4	48-22-8455	Foam Insert for PACKOUT™ Kit Box (Set of 2)	(1)

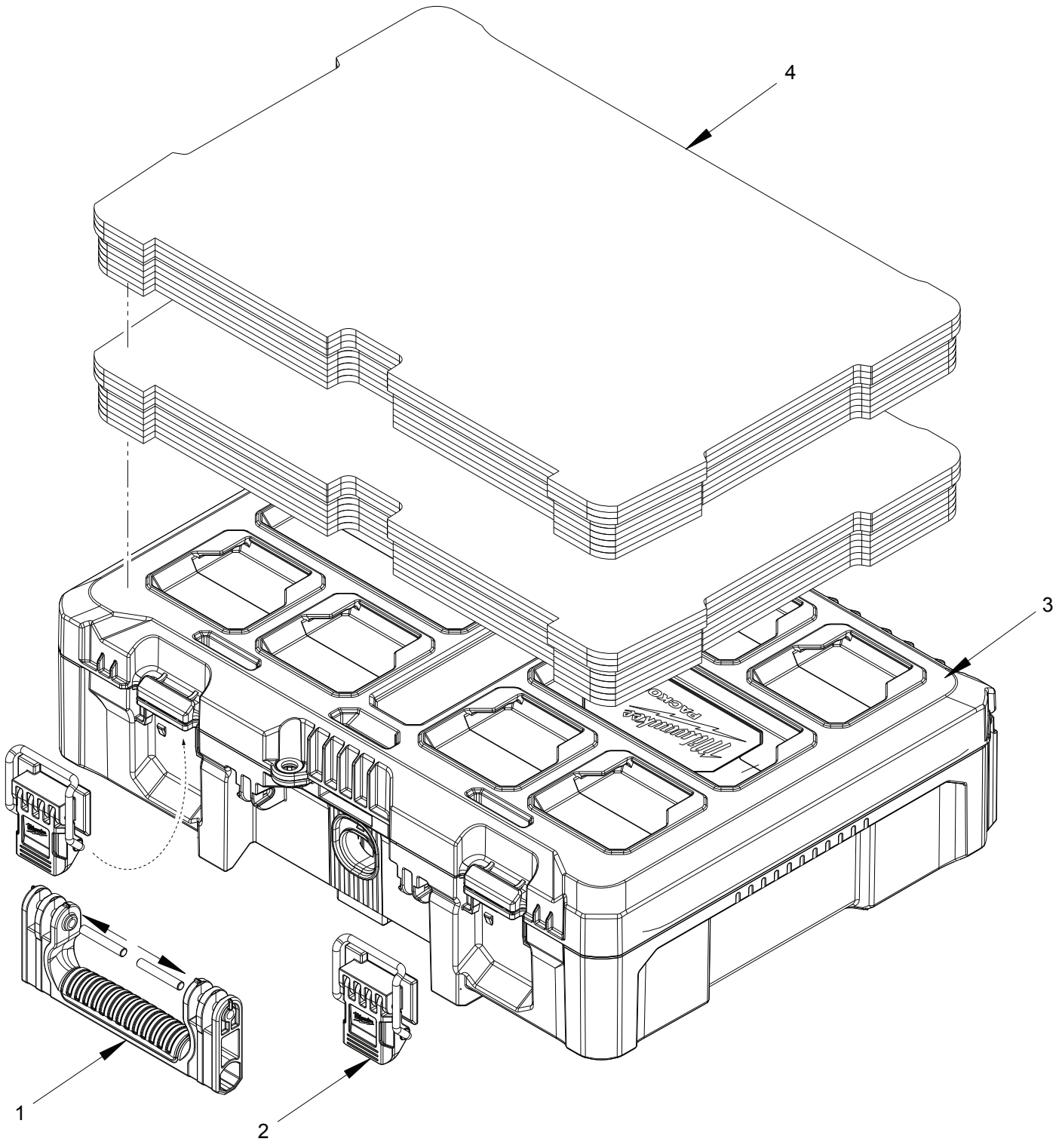

**48-22-8321 15" PACKOUT™ (Medium) Tool Bag\***

**SPECIAL NOTE:** There are two locker designs for the 15" model. An early version of the 48-22-8321 had a different locker system. The design used in the 20" model was incorporated in later production of the 15" model. See page two.



**48-22-8322 20" PACKOUT™ (Large) Tool Bag\***



**\*48-22-8321 15" PACKOUT™ (Medium) Tool Bag**

**\*48-22-8322 20" PACKOUT™ (Large) Tool Bag**

FIG.	PART NO.	DESCRIPTION OF PART	NO. REQ.
1	45-56-8300	Shoulder Strap (For both tote models)	(1)
2	44-20-8300	Locker Kit (For early versions of 48-22-8321) See page two	(1)
3	44-20-0305	Locker (For 48-22-8322 and later versions of 48-22-8321) See page 5	(1)

**SEE PAGE 5 FOR INSTRUCTIONS ON REMOVING SELECTION AND INSTALLING BOTH LOCKER SYSTEMS**





48-22-8300 PACKOUT™ Tech Bag



48-22-8301 PACKOUT™ Jobsite Backpack



48-22-8302 PACKOUT™ Jobsite Cooler



FIG.	PART NO.	DESCRIPTION OF PART	NO. REQ.
1	45-56-8300	Shoulder Strap (For Cooler & Tech Bag)	(1)
2	44-20-0305	Locker System	(1)

**SEE PAGE 5 FOR INSTRUCTIONS ON REMOVING AND INSTALLING BOTH LOCKER SYSTEMS**

