



HIGH BAY 360° SENSOR CEILING MOUNT • LOW VOLTAGE • PASSIVE INFRARED (PIR)

SPECIFICATIONS

FEATURES

- 100% Digital PIR Detection, Excellent RF Immunity
- 360° Coverage Pattern
- Up to 45 ft Mounting
- Push-Button Programmable
- User Adjustable Time Delays
- No Field Calibration or Sensitivity Adjustments Required
- Convenient Test Mode
- 100 hr Lamp Burn-in Timer
- Green LED Indicator

LAMPMAXIMIZER® TECHNOLOGY

- Protects Lamp Life while Maximizing Energy Savings
- Minimum On Timer (15 min default)
- Occ. Time Delay (10 min default)
- LampMaximizer+ Mode - Optimizes Lamp Life & Energy Savings (disabled by default)
- Switch Counter (in 1000's)
- Total Lamp On Time (in khrs)

PHYSICAL SPECS

SIZE 4.55" Dia. (11.56 cm)
1.55" Deep (3.94 cm)

WEIGHT 6 oz

MOUNTING

- Ceiling Tile Surface
 - 3.5" Octagon Box
 - Single Gang Handy Box
- COLOR White

ELECTRICAL SPECS

OPERATING VOLTAGE

12-24 VAC/VDC

CURRENT DRAW

Standard, 4 mA
w/ R option, 16 mA

DIMMING LOAD Sinks < 20mA;
~40 Ballasts @ .5mA each

RECOMMENDED POWER PACK
PP20

ENVIRONMENTAL SPECS

OPERATING TEMP

14° to 160° F (-10° to 71° C)

RELATIVE HUMIDITY

20 to 90% non-condensing

SILICONE FREE

ROHS COMPLIANT

OVERVIEW

Designed for mounting heights of up to 45 ft (13.72 m), the **CM 6** High Bay 360° sensor provides Passive Infrared (PIR) occupancy detection over a 15-20 ft (4.57- 6.10 m) radial coverage pattern that overlaps the areas lit by a typical high bay fixture. Applications include warehouses, racquetball courts, and gymnasiums. Multiple fixture control is best handled by using multiple **CM 6** sensors together as needed. When used with standard power packs, these sensors are ideal for on/off control of T5/T8 fluorescent lighting. However, HID bi-level fixtures can also be controlled when the **CM 6** is partnered with a **PP20 SH** power pack with the start-to-high feature. For lower mounting height applications, **CM 9** or **CM 10** Series sensors are recommended.

SENSOR OPERATION

The sensor detects changes in the infrared energy given off by occupants as they move within the field-of-view. When occupancy is detected, a DC output goes high and can drive up to 200 mA of connected load. The sensor is powered with 12-24 VAC/VDC and typically operates with a **PP20** or **MP20** power pack, enabling complete 20 Amp circuits to be controlled. This innovative sensor requires no field calibration or sensitivity adjustments.

LAMPMAXIMIZER®

This sensor also contains patent pending LampMaximizer technology that allows users to aggressively target energy savings while still protecting lamp life. A minimum on timer, factory set at 15 minutes, helps preserve lamp life by eliminating all lamp cycles shorter than lamp manufacturers' recommendations specify.

A standard occupancy time delay is also present that ensures lights turn off (assuming minimum on timer has elapsed) if no occupancy is detected. This timer is factory set at 10 minutes to promote energy savings, but is adjustable between 30 seconds and 20 minutes. These adjustments can be done manually, through the unit's push-button, or automatically every two weeks through an advanced mode, called LampMaximizer+, that determines the optimum time delay in order to maximize both lamp life and energy savings. Additionally, this sensor maintains statistics on total lamp on time and number of cycles.

OPTIONS

LOW VOLTAGE RELAY (R)

- Enables sensors to interface with other systems (e.g., BMS, lighting panels)
- Provides dry contact closure via a SPDT, 1 Amp, 40 Volt relay
- Only one relay needed per zone
- Changes state when all connected sensors register unoccupied
- Relay requires sensor power to function

OCCUPANCY CONTROLLED DIMMING (D)

- Provides dimming output to control 0-10 VDC dimmable ballasts
- Provides a second occupancy time-out period that enables the lights to go to a dim setting before turning off
- Adjustable max/min dim setting
- Only one sensor per zone needs to have dimming output

PHOTOCELL (P)

- Auto set-point calibration
- Two selectable modes of operation
- On/Off mode: Photocell has full control during periods of occupancy
- Inhibit mode: Photocell can prevent lights from turning on if adequate daylight is available, but cannot turn lights off

LOW TEMP/HIGH HUMIDITY (LT)

- Sensor is corrosion resistant to moisture
- Operates down to -40° F/C



TITLE 24
ASSEMBLED in U.S.A.
5 YEAR WARRANTY

ORDERING INFO CM 6 [RELAY] [DIMMING/PHOTOCELL] [TEMP/HUMIDITY]

RELAY

- Blank = None
- R = Low Voltage Relay

DIMMING / PHOTOCELL CHOOSE ONE ONLY

- Blank = None
- D = Occupancy Controlled Dimming
- P = Photocell

TEMP/HUMIDITY

- Blank = Standard
- LT = Low Temp

COVERAGE PATTERN

6 HIGH BAY 360° LENS

- Best choice for 15 to 45 ft (4.57 to 13.72 m) mounting heights
- 15 to 20 ft (4.57 to 6.10 m) radial coverage overlaps area lit by a typical high bay fixture
- Excellent detection of large motion (e.g. **walking**) up to a 35 ft (10.76 m) mounting height
- Excellent detection of extra large motion (e.g. **forklifts**) up to a 45 ft (13.72 m) mounting height

LOW VIEW

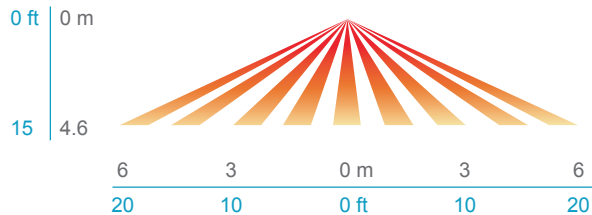

HIGH VIEW

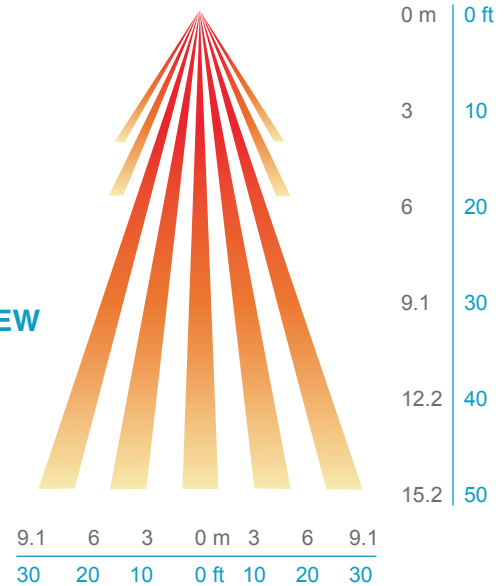

WIRING (DO NOT WIRE HOT)

STANDARD WIRING

- RED** - Power Input (12-24 VAC/VDC)
- BLACK** - Common
- WHITE** - Occupancy State (high VDC for occupied)

PHOTOCELL/DIMMING OPTIONS (D, P)

BLUE - Direct output to power pack for providing photocell control and/or secondary dim time out. Output is high VDC with occupancy & low light. Output also held high during secondary dim time out. For multi-level control, use two power packs and connect White wire to primary load and Blue to daylight load.

VIOLET w/ WHITE STRIPE - Connect to 0-10 VDC control wire (typically Violet) from 0-10 VDC dimmable ballast

GRAY from Ballast - Connect to sensor Black wire

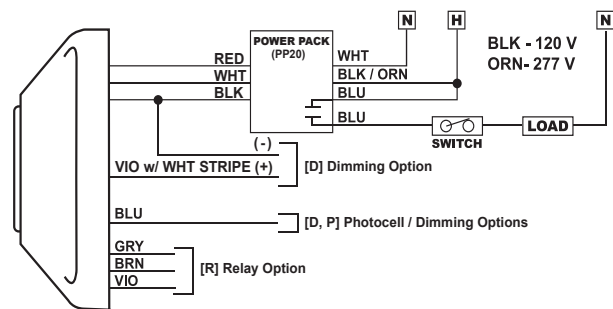

RELAY OPTION (R)

GRAY / BROWN - Connected during occupied state

VIOLET / BROWN - Connected during unoccupied state

Note: Relay is energized during unoccupied state

INSTALLATION

- Mount sensor directly to a ceiling tile or a metallic grid (two self-tapping screws provided).
- Sensor's mounting holes also align with 3.5" octagon or single gang handy box (screws not provided).
- Sensor will detect motions crossing segments more effectively than motions parallel to beams.
- For optimal detection, position sensor such that segments are crossed upon entrance and unable to view outside the space.

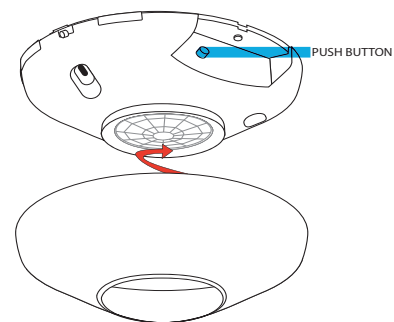

PROGRAMMING

Refer to instruction card IC7.001 for default settings and directions on programming the sensor via the push-button.

sensorswitch

WARRANTY: Sensor Switch, Inc. warrants these products to be free of defects in manufacture and workmanship for a period of 60 months. Sensor Switch, Inc., upon prompt notice of such defect, will, at its option, provide a Returned Material Authorization number and repair or replace returned product.

LIMITATIONS AND EXCLUSIONS: This Warranty is in full lieu of all other representation and expressed and implied warranties (including the implied warranties of merchantability and fitness for use) and under no circumstances shall Sensor Switch, Inc. be liable for any incidental or consequential property damages or losses.

An **AcuityBrands** Company

TS-CM-002A