

1451-2E



Color:  Black

UPC Code: 07847713558

Country of Origin: United States - **Eligible for ARRA funded projects*



**May include one or more globally sourced components.*



Brand Features

Tried-and-true toggle designs, Leviton Residential Grade AC Quiet Switches cover all the bases; they install easily and are available in standard and illuminated versions. Their toggles and frames are constructed of impact-resistant thermoplastic, and they feature large head, hardened triple-drive screws for easy installation. Leviton's traditional switches are compatible with a wide range of Leviton plastic and metal wallplates.

Item Description

15 Amp, 120 Volt, Toggle Framed Single-Pole AC Quiet Switch, Residential Grade, Grounding, Quickwire Push-In & Side Wired, - Black

Technical Information

Product Features

Grounding: Grounding

Feature: Framed

Amperage: 15 Amp

Voltage: 120 VAC

Voltage: 120 Volt

HP Rating: 1/2HP-120V

Max. Amperage: 12 Amp

Termination: Quickwire Push-In & Side

Actuator Material: Thermoplastic

Body Material: Thermoplastic

Strap Material: Steel

Color: Black

Standards and Certifications: UL/CSA

Warranty: 2 Year Limited

Features and Benefits

- Faster installation with combination of side wiring and Quickwire push-in wiring
- Quickwire accepts conductors up to #14 AWG.
- Side wire accepts conductors up to #12 AWG
- Large head triple-drive combination screws (Standard, Phillips, Robertson) for fast wiring installation
- Impact-resistant, durable thermoplastic toggle and frame
- Backed by a Limited Two-Year Warranty

Dimensional Diagram

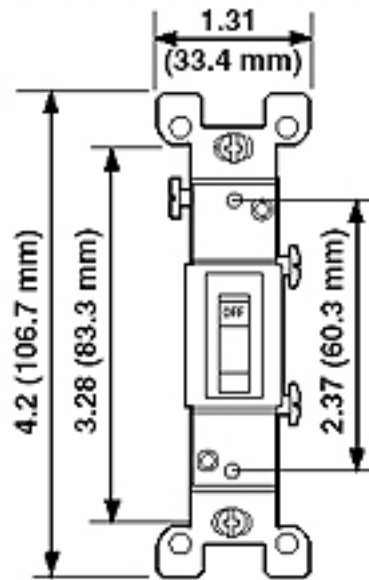

Wiring Diagram Single Pole

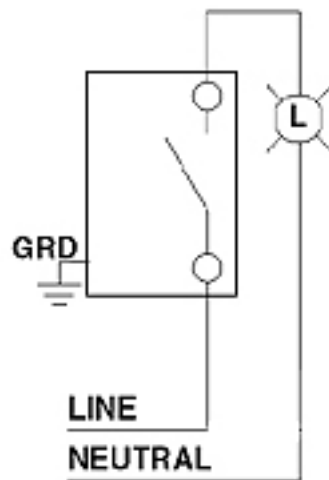

SPECIFICATION SUBMITTAL

JOB NAME: <input type="text"/>	CATALOG NUMBERS: <input type="text"/>	
JOB NUMBER: <input type="text"/>	<input type="text"/>	<input type="text"/>

Leviton Manufacturing Co., Inc.

201 North Service Road, Melville, NY 11747

Telephone: 1-800-323-8920 · FAX: 1-800-832-9538 · Tech Line (8:30AM-7:30PM E.S.T. Monday-Friday): 1-800-824-3005

Leviton Manufacturing of Canada, Ltd.

165 Hymus Boulevard, Pointe Claire, Quebec H9R 1E9 · Telephone: 1-800-469-7890 ·

FAX: 1-800-824-3005 · www.leviton.com/canada

Leviton S. de R.L. de C.V.

Lago Tana 43, Mexico DF, Mexico CP 11290 · Tel.: (+52)55-5082-1040 · FAX: (+52)5386-1797 · www.leviton.com.mx

Visit our Website at: www.leviton.com

© 2012-2016 Leviton Manufacturing Co., Inc. All rights reserved. Subject to change without notice.



Leviton has a global presence.

If you would like to know where your local Leviton office is located please go to: www.leviton.com/international/contacts/

**Buy American Compliant Logo -- The American Recovery And Reinvestment Act of 2009 ("ARRA") provides federal grants and loans for projects throughout the country. Section 1605 of the Act, named the "Buy American" provision, requires that certain materials and manufactured products used in projects funded by the Act be manufactured in the United States. The appearance of the Recovery Act Logo in relation to a Leviton product is only intended to reflect that such product may be used in an ARRA funded project. It does not mean that such product or Leviton is sponsored or endorsed by, or that Leviton receives funds from, the federal government or the Recovery Accountability and Transparency Board. Nothing in Leviton's use of the logo is intended to suggest anything regarding the requirements for funding under ARRA.*