

TAP SETS

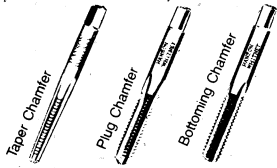

Each Set
Contains
Three
Taps:

EXPLANATION OF DESCRIPTION

SIZE	THREAD	NO. FLUTES	TYPE FLUTE Symbol Explanation	PITCH DIA. LIMIT NO.
Numbered Sizes and Fractional Sizes as Shown	Number of Threads per inch	3	FL	H2
		4	Str. Flute	H3

**THE HANSON-WHITNEY
COMPANY**
*High Speed Steel...
Ground Thread
MADE IN USA*

ORDER BY SET NUMBERS OR INDIVIDUAL TAP NUMBER

SET NO.	SET DESCRIPTION					THRD SIZES	INDIVIDUAL TAPS NOS.		
							Taper	Plug	Bottoming
Machine Screw Tap Sets:									
10685	4-40	3FL	H2	Set	4-40	10686	10687	10688	
10805	4-48	3FL	H2	Set	4-48	10806	10807	10808	
10925	4-36	3FL	H2	Set	4-36	10926	10927	10928	
11300	6-32	3FL	H3	Set	6-32	11301	11302	11303	
11470	6-40	3FL	H2	Set	6-40	11471	11472	11473	
11710	8-32	4FL	H3	Set	8-32	11711	11712	11713	
12030	8-36	4FL	H2	Set	8-36	12031	12032	12033	
12330	10-24	4FL	H3	Set	10-24	12331	12332	12333	
12675	10-32	4FL	H3	Set	10-32	12676	12677	12678	
Hand Tap Sets:									
20135	1/4-20	4FL	H3	Set	1/4-20	20136	20137	20138	
20635	1/4-28	4FL	H3	Set	1/4-28	20636	20637	20638	
21135	5/16-18	4FL	H3	Set	5/16-18	21136	21137	21138	
21635	5/16-24	4FL	H3	Set	5/16-24	21636	21637	21638	
22075	3/8-16	4FL	H3	Set	3/8-16	22076	22077	22078	
22575	3/8-24	4FL	H3	Set	3/8-24	22576	22577	22578	
23075	7/16-14	4FL	H3	Set	7/16-14	23076	23077	23078	
23575	7/16-20	4FL	H3	Set	7/16-20	23576	23577	23578	
24075	1/2-13	4FL	H3	Set	1/2-13	24076	24077	24078	
24575	1/2-20	4FL	H3	Set	1/2-20	24576	24577	24578	
25010	9/16-12	4FL	H3	Set	9/16-12	25011	25012	25013	
25510	9/16-18	4FL	H3	Set	9/16-18	25511	25512	25513	
26010	5/8-11	4FL	H3	Set	5/8-11	26011	26012	26013	
26510	5/8-18	4FL	H3	Set	5/8-18	26511	26512	26513	

TAPPERS

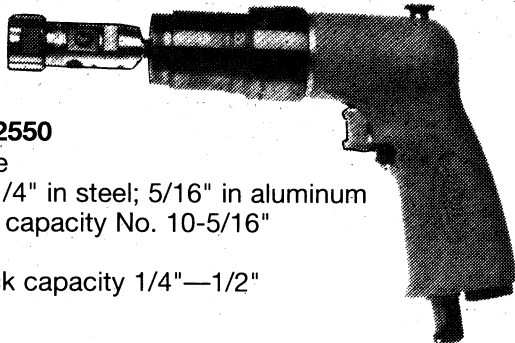

No. O2550

- Rapid reverse
- Capacity of 1/4" in steel; 5/16" in aluminum
- O2550 chuck capacity No. 10-5/16" thread size
- O2550B chuck capacity 1/4"—1/2" thread size



**No. 2P2550
No. 2-1/2 Series
3/4 HP**

- 2P2550—chuck capacity from No. 10-5/16" thread size
- 2P2550B—chuck capacity 1/4"—1/2" thread size

Handle		R.P.M. No Load	Cat. No.	Side To Center Ins.	Torque In. Lbs.	Hose Conn.	Min. Hose Size	Overall Length Ins.	Net Weight Tool Only Lbs. Oz.
Pistol	Rev.	400	2P2550	29/32	310	1/4"PT	3/8"	8-1/4	2-15
		350	O2550	29/32	110	1/4"PT	3/8"	8-1/2	3

Suffix Cat. No. with "B" for 1/4"—1/2" chuck capacity.