

The G-Series Grinders — What You See Is What You Get ... Times Three

Configurable front-ends to meet your needs

- Straight die grinders
- Angle die grinders
- Straight grinders (type 1 wheels)
- Angle grinders (type 1 and type 27 wheels)

Improved efficiency means big power in a small package

Ergonomic low-profile locking throttle lever for operator safety

Easy attachment of pipe exhaust



6" guard for greater application coverage (G2 Series and G3 Series)

Ergonomic D-shaped handle for operator comfort

Laser-etched product information won't wear off



From the compact 0.4 hp G1 Series to the powerful 1.35 hp G3 Series, these grinders are made to order for any grinding, cutting, and material removal needs. Engineered and built with Ingersoll Rand reliability and durability, the G-Series has the features operators want most. With our G-Series industrial grinders, your total cost of ownership is reduced. You get the job done faster with greater power, and the easy serviceability of the G-Series means shorter downtimes and fewer parts in inventory.

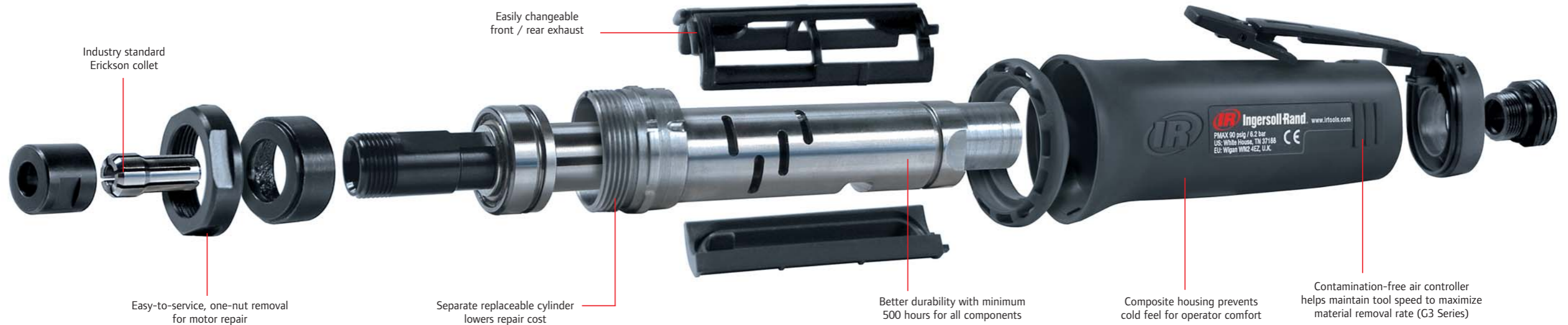

Industry standard Erickson collet

Easy-to-service, one-nut removal for motor repair

Easily changeable front / rear exhaust

Separate replaceable cylinder lowers repair cost

Better durability with minimum 500 hours for all components

Composite housing prevents cold feel for operator comfort

Contamination-free air controller helps maintain tool speed to maximize material removal rate (G3 Series)

G1 SERIES



- At 0.4 hp, the G1 Series packs a lot of power in a small package.
- Ideal for light material removal, cleaning rough castings, deburring parts, cleaning up welds, and other finishing tasks.
- Ergonomic D-shaped handle fits better in your hand.
- Low noise and vibration.
- One-nut access for all motor servicing.
- Available in angle, horizontal, and extended horizontal configurations.

G2 SERIES



- Perfect for bigger jobs, the G2 Series performs at an impressive 0.8 hp.
- Ergonomic D-shaped handle fits better in your hand.
- One-nut access for all motor servicing.
- Suited for heavier-duty grinding, cutting, cleaning, and polishing applications.
- Available in angle, horizontal, extended angle, and extended horizontal configurations.

G3 SERIES



- Superior power-to-weight ratio — the G3 Series delivers a mighty 1.35 hp.
- The biggest jobs demand the most power.
- Internal contamination-free air controller helps maintain tool speed to maximize material removal rate.
- Ideal for industrial-duty material removal with burrs, grinding wheels, and coated abrasives.
- Available in angle, horizontal, extended horizontal, and extended angle configurations.
- Vibration-reducing handle, allowing end user extended operation.

G1 Series



G1A200RG4



G1A200RH63



G1A200RS812



G1H200FG4



G1H200RH63



G1X350RG4

Model	hp	rpm	Exhaust	Output	Type	lb (kg)	in (mm)	in (mm)	cfm
G-SERIES ANGLE GRINDERS									
G1A120FG4	0.4	12,000	Front	1/4" collet	N/A	1.1 (0.5)	6.0" (152)	3.0" (76)	19
G1A120RG4	0.4	12,000	Rear	1/4" collet	N/A	1.1 (0.5)	6.0" (152)	3.0" (76)	19
G1A200FG4	0.4	20,000	Front	1/4" collet	N/A	1.1 (0.5)	6.0" (152)	3.0" (76)	25
G1A200RG4	0.4	20,000	Rear	1/4" collet	N/A	1.1 (0.5)	6.0" (152)	3.0" (76)	25
G1A200RH63	0.4	20,000	Rear	3/8" - 24 thread, 3" guard	1	1.3 (0.6)	6.0" (152)	1.9" (48)	25
G1A200RP63	0.4	20,000	Rear	3/8" - 24 thread, 3" guard	27, 28	1.3 (0.6)	6.0" (152)	1.9" (48)	25
G-SERIES ANGLE SANDERS									
G1A120RS418	0.4	12,000	Rear	1/4" x 18" belt	N/A	1.2 (0.5)	14.0" (355)	N/A	19
G1A120RS4	0.4	12,000	Rear	1/4" - 20 thread	N/A	1.1 (0.5)	6.0" (152)	3.0" (76)	19
G1A120RS812	0.4	12,000	Rear	1/2" x 12" belt	N/A	1.2 (0.5)	10.8" (274)	N/A	19
G1A120RS818	0.4	12,000	Rear	1/2" x 18" belt	N/A	1.5 (0.7)	14.0" (355)	N/A	19
G1A200RS4	0.4	20,000	Rear	1/4" - 20 thread	N/A	1.1 (0.5)	6.0" (152)	3.0" (76)	25
G1A200RS812	0.4	20,000	Rear	1/2" x 12" belt	N/A	1.2 (0.5)	10.8" (274)	N/A	25
G1A200RS818	0.4	20,000	Rear	1/2" x 18" belt	N/A	1.5 (0.7)	14.0" (355)	N/A	25
G-SERIES HORIZONTAL GRINDERS									
G1H200FG4	0.4	20,000	Front	1/4" collet	N/A	0.9 (0.4)	6.1" (155)	N/A	19
G1H200RG4	0.4	20,000	Rear	1/4" collet	N/A	0.9 (0.4)	6.1" (155)	N/A	19
G1H200RH63	0.4	20,000	Rear	3/8" - 24 thread, 3" guard	1	1.2 (0.5)	6.1" (155)	N/A	19
G1H250RH63	0.4	25,000	Rear	3/8" - 24 thread, 3" guard	1	1.2 (0.5)	6.1" (155)	N/A	20
G1H250FG4	0.4	25,000	Front	1/4" collet	N/A	0.9 (0.4)	6.1" (155)	N/A	20
G1H250RG4	0.4	25,000	Rear	1/4" collet	N/A	0.9 (0.4)	6.1" (155)	N/A	20
G1H350FG4	0.4	35,000	Front	1/4" collet	N/A	0.9 (0.4)	6.1" (155)	N/A	25
G1H350RG4	0.4	35,000	Rear	1/4" collet	N/A	0.9 (0.4)	6.1" (155)	N/A	25
G-SERIES EXTENDED HORIZONTAL GRINDERS									
G1X200RG4	0.4	20,000	Rear	1/4" collet	N/A	1.3 (0.6)	9.1" (231)	N/A	25
G1X250RG4	0.4	25,000	Rear	1/4" collet	N/A	1.3 (0.6)	9.1" (231)	N/A	25
G1X350RG4	0.4	35,000	Rear	1/4" collet	N/A	1.3 (0.6)	9.1" (231)	N/A	25

G2 Series



Model	hp	rpm	Exhaust	Output	Type	lb (kg)	in (mm)	in (mm)	cfm
G-SERIES ANGLE GRINDERS									
G2A090RG4	0.8	9,000	Rear	1/4" collet	N/A	2.3 (1)	7.8" (198)	3.0" (76)	36
G2A090RP64	0.8	9,000	Rear	3/8" - 24 thread, 4" guard	27, 28	3.0 (1.3)	7.8" (198)	2.5" (63)	36
G2A120RG4	0.8	12,000	Rear	1/4" collet	N/A	2.3 (1)	7.8" (198)	3.0" (76)	36
G2A120RP1045	0.8	12,000	Rear	5/8" - 11 thread, 4.5" guard	27, 28	3.2 (1.4)	7.8" (198)	2.4" (61)	36
G2A120RP105	0.8	12,000	Rear	5/8" - 11 thread, 5" guard	27, 28	3.6 (1.6)	7.8" (198)	2.4" (61)	36
G2A120RP64	0.8	12,000	Rear	3/8" - 24 thread, 4" guard	27, 28	3.0 (1.3)	7.8" (198)	2.5" (63)	36
G2A150RP64	0.8	15,000	Rear	3/8" - 24 thread, 4" guard	27, 28	3.0 (1.3)	7.8" (198)	2.5" (63)	36
G2A180RG4	0.8	18,000	Rear	1/4" collet	N/A	2.3 (1)	7.8" (198)	3.0" (76)	36
G2A180RH64	0.8	18,000	Rear	3/8" - 24 thread, 4" guard	1	2.7 (1.2)	7.8" (198)	2.6" (66)	36
G2A180RP63	0.8	18,000	Rear	3/8" - 24 thread, 3" guard	27, 28	3.1 (1.4)	7.8" (198)	2.5" (63)	36
G-SERIES ANGLE SANDERS									
G2A100RS10	0.8	10,000	Rear	5/8" - 11 thread	N/A	2.7 (1.2)	7.8" (198)	3.0" (76)	36
G2A120RS10	0.8	12,000	Rear	5/8" - 11 thread	N/A	2.7 (1.2)	7.8" (198)	3.0" (76)	36
G2A135RS10	0.8	13,500	Rear	5/8" - 11 thread	N/A	2.7 (1.2)	7.8" (198)	3.0" (76)	36
G-SERIES HORIZONTAL GRINDERS									
G2H180FG4	0.8	18,000	Front	1/4" collet	N/A	1.6 (0.7)	7.4" (188)	N/A	36
G2H180RG4	0.8	18,000	Rear	1/4" collet	N/A	1.6 (0.7)	7.4" (188)	N/A	36
G2H200FG4	0.8	20,000	Front	1/4" collet	N/A	1.6 (0.7)	7.4" (188)	N/A	36
G2H200RG4	0.8	20,000	Rear	1/4" collet	N/A	1.6 (0.7)	7.4" (188)	N/A	36
G2H250FG4	0.8	25,000	Front	1/4" collet	N/A	1.6 (0.7)	7.4" (188)	N/A	36
G2H250RG4	0.8	25,000	Rear	1/4" collet	N/A	1.6 (0.7)	7.4" (188)	N/A	36
G-SERIES EXTENDED ANGLE GRINDERS									
G2E135RG4	0.8	13,500	Rear	1/4" collet	N/A	2.6 (1.1)	10.4" (264)	3.0" (76)	36
G2E135RH64	0.8	13,500	Rear	3/8" - 24 thread, 4" guard	1	2.0 (0.9)	10.4" (264)	2.6" (66)	36
G2E135RP64	0.8	13,500	Rear	3/8" - 24 thread, 4" guard	27, 28	3.0 (1.3)	10.4" (264)	2.6" (66)	36
G2L100RP106	0.8	10,000	Rear	5/8" - 11 thread, 6" guard	27, 28	4.4 (1.9)	12.6" (320)	2.4" (61)	36
G2L120RP1045	0.8	12,000	Rear	5/8" - 11 thread, 4.5" guard	27, 28	4.4 (1.9)	12.6" (320)	2.4" (61)	36
G2L120RP64	0.8	12,000	Rear	3/8" - 24 thread, 4" guard	27, 28	4.4 (1.9)	12.6" (320)	2.5" (63)	36
G-SERIES EXTENDED ANGLE SANDERS									
G2L075FS10	0.8	7,500	Front	5/8" - 11 thread	N/A	2.6 (1.1)	10.4" (264)	3.0" (76)	36
G2L120RS10	0.8	12,000	Rear	5/8" - 11 thread	N/A	2.0 (0.9)	10.4" (264)	2.6" (66)	36
G-SERIES EXTENDED HORIZONTAL GRINDERS									
G2S180RH63	0.8	18,000	Rear	3/8" - 24 thread, 3" guard	1	2.5 (1.1)	8.6" (218)	N/A	36
G2X180RG4	0.8	18,000	Rear	1/4" collet	N/A	2.7 (1.2)	12.1" (307)	N/A	36
G2X180RH63	0.8	18,000	Rear	3/8" - 24 thread, 3" guard	1	3.2 (1.4)	12.4" (315)	N/A	36
G2X180RH64	0.8	18,000	Rear	3/8" - 24 thread, 4" guard	1	3.5 (1.6)	12.4" (315)	N/A	36
G2X200RG4	0.8	20,000	Rear	1/4" collet	N/A	2.7 (1.2)	12.1" (307)	N/A	36
G2X250RG4	0.8	25,000	Rear	1/4" collet	N/A	2.7 (1.2)	12.1" (307)	N/A	36

G3 Series



Model	hp	rpm	Exhaust	Output	Type	lb (kg)	in (mm)	in (mm)	cfm
G-SERIES ANGLE GRINDERS									
G3A100RP106	1.35	10,000	Rear	5/8" - 11 thread, 6" guard	27, 28	4.9 (2.2)	9.6" (244)	3.6" (91)	33
G3A120RG4	1.35	12,000	Rear	1/4" collet	N/A	3.7 (1.6)	9.5" (241)	3.3" (84)	55
G3A120RP1045	1.35	12,000	Rear	5/8" - 11 thread, 4.5" guard	27, 28	4.6 (2)	9.6" (244)	3.6" (91)	55
G3A120RP105	1.35	12,000	Rear	5/8" - 11 thread, 5" guard	27, 28	4.7 (2.1)	9.6" (244)	3.6" (91)	55
G-SERIES HORIZONTAL GRINDERS									
G3H150RG4	1.35	15,000	Rear	1/4" collet	N/A	2.3 (1)	9.1" (231)	N/A	33
G3H180RG4	1.35	18,000	Rear	1/4" collet	N/A	2.3 (1)	9.1" (231)	N/A	55
G-SERIES EXTENDED ANGLE SANDERS									
G3L086RS10	1.35	8,600	Rear	5/8" - 11 thread	N/A	4.3 (1.9)	13.0" (330)	3.0" (76)	33
G-SERIES EXTENDED HORIZONTAL GRINDERS									
G3X150RG4	1.35	15,000	Rear	1/4" collet	N/A	3.7 (1.6)	14.1" (358)	N/A	33
G3X150RH64	1.35	15,000	Rear	3/8" - 24 thread, 4" guard	1	4.5 (2)	14.1" (358)	N/A	33
G3X180RG4	1.35	18,000	Rear	1/4" collet	N/A	3.7 (1.6)	14.1" (358)	N/A	55
G3X180RH63	1.35	18,000	Rear	3/8" - 24 thread, 3" guard	1	4.5 (2)	14.1" (358)	N/A	55

Air inlet for: G1, G2 - 1/4" NPT; G3 - 3/8" NPT
 Recommended hose size: G1, G2 - 3/8"; G3 - 1/2"
 Performance figures are at 90 psi air pressure.

