

SCREW: SEE CHART
 CAT. NO.: SEE CHART
 INFORMATION SHEET: FORM 18

MATERIAL: ALUMINUM, X1428
 PLATING: WAX
 MARKING: UTILCO, PET 350, 350MCM-10, AL-CU

REV: W
 DRAWN BY: CLH
 DATE: 9/26/2007
 SCALE: 1:1
 SIZE: B



DWG NO: **N7865**
 SHEET: 1 OF 1

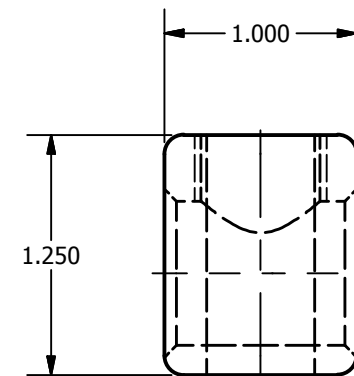
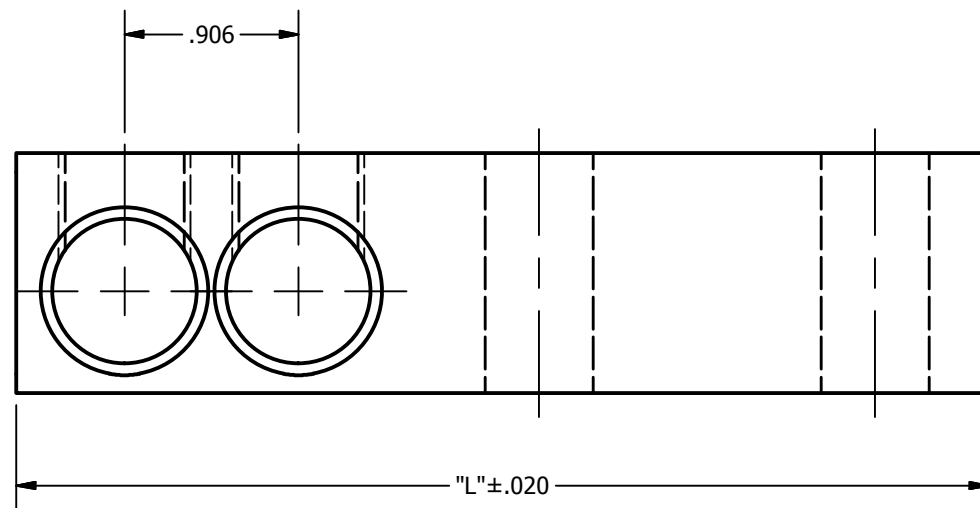
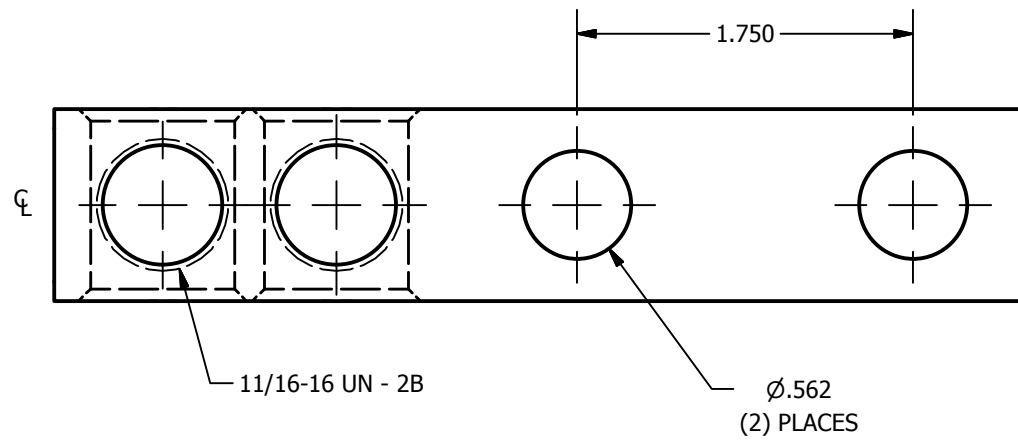

SEE CHART FOR SCREW
 FLUSH TO TOP

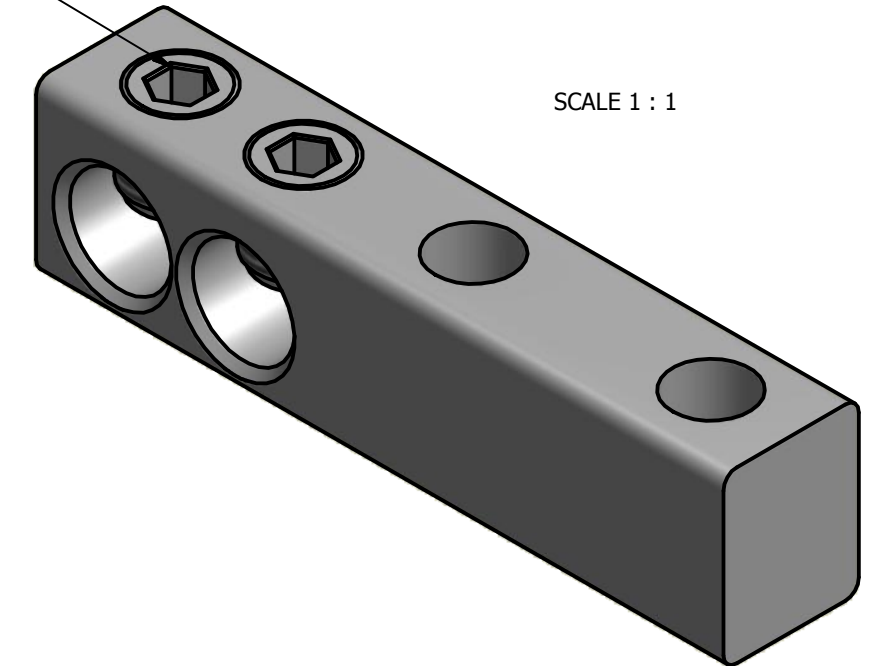

SCALE 1 : 1

CATALOG NUMBER	OUTLETS	"L"	SCREW
PET2-350	2	5.062	
PET3-350	3	5.969	
PET4-350	4	6.875	E1411C00T
PET5-350	5	7.781	E1411C00T
PET6-350	6	8.687	E1411C00T
PET7-350	7	9.593	
PET8-350	8	10.500	E1411C00T
PET2-350D	2	5.062	
PET3-350D	3	5.969	
PET4-350D	4	6.875	
PET5-350D	5	7.781	
PET6-350D	6	8.687	
PET7-350D	7	9.593	
PET8-350D	8	10.500	E6096C00T
PET2-350T	2	5.062	
PET3-350T	3	5.969	
PET4-350T	4	6.875	E1411C00T
PET5-350T	5	7.781	
PET6-350T	6	8.687	
PET7-350T	7	9.593	
PET8-350T	8	10.500	