

Product availability : Stock - Normally stocked in distribution facility

Price* : 214.00 USD



Main

| | |
|---------------------------|---------------------|
| Range of product | Zelio Logic |
| Product or component type | Compact smart relay |

Complementary

| | |
|--------------------------------|--|
| Local display | Without |
| Number or control scheme lines | 240 with ladder programming |
| Cycle time | 6...90 ms |
| Backup time | 10 years at 77 °F (25 °C) |
| Clock drift | 6 s/month at 77 °F (25 °C) 12 min/year at 32...131 °F (0...55 °C) |
| Checks | Program memory on each power up |
| [Us] rated supply voltage | 24 V DC |
| Supply voltage limits | 19.2...30 V |
| Supply current | 100 mA (without extension) |
| Power dissipation in W | 3 W without extension |
| Reverse polarity protection | With |
| Discrete input number | 6 conforming to EN/IEC 61131-2 type 1 |
| Discrete input type | Resistive |
| Discrete input voltage | 24 V DC |
| Discrete input current | 4 mA |
| Counting frequency | 1 kHz for discrete input |
| Voltage state 1 guaranteed | >= 15 V for I1...IA and IH...IR discrete input circuit >= 15 V for IB...IG used as discrete input circuit |
| Voltage state 0 guaranteed | <= 5 V for I1...IA and IH...IR discrete input circuit <= 5 V for IB...IG used as discrete input circuit |
| Current state 1 guaranteed | >= 1.2 mA for IB...IG used as discrete input circuit >= 2.2 mA for I1...IA and IH...IR discrete input circuit |

| | |
|--|---|
| Current state 0 guaranteed | <= 0.5 mA for IB...IG used as discrete input circuit <= 0.75 mA for I1...IA and IH...IR discrete input circuit |
| Input compatibility | 3-wire proximity sensors PNP (discrete input) |
| Input impedance | 12 kOhm (IB...IG used as analogue input circuit) 12 kOhm (IB...IG used as discrete input circuit) 7.4 kOhm (I1...IA and IH...IR discrete input circuit) |
| Number of outputs | 4 relay output(s) |
| Output voltage limits | 24...250 V AC (relay output) 5...30 V DC (relay output) |
| Contacts type and composition | NO relay output |
| Output thermal current | 8 A for all 4 outputs (relay output) |
| Electrical durability | 500000 cycles AC-12at 230 V, 1.5 A for relay output conforming to EN/IEC 60947-5-1 500000 cycles AC-15at 230 V, 0.9 A for relay output conforming to EN/IEC 60947-5-1 500000 cycles DC-12at 24 V, 1.5 A for relay output conforming to EN/IEC 60947-5-1 500000 cycles DC-13at 24 V, 0.6 A for relay output conforming to EN/IEC 60947-5-1 |
| Switching capacity in mA | >= 10 mA at 12 V (relay output) |
| Operating rate in Hz | 0.1 Hz (at Ie) for relay output 10 Hz (no load) for relay output |
| Mechanical durability | 10000000 cycles (relay output) |
| [Uimp] rated impulse withstand voltage | 4 kV conforming to EN/IEC 60947-1 and EN/IEC 60664-1 |
| Clock | Without |
| Response time | 10 ms (from state 0 to state 1) relay output 5 ms (from state 1 to state 0) relay output |
| Connections - terminals | Screw terminals, clamping capacity: 1 x 0.2...1 x 2.5 mm ² AWG 25...AWG 14 semi-solid Screw terminals, clamping capacity: 1 x 0.2...1 x 2.5 mm ² AWG 25...AWG 14 solid Screw terminals, clamping capacity: 1 x 0.25...1 x 2.5 mm ² AWG 24...AWG 14 flexible with cable end Screw terminals, clamping capacity: 2 x 0.2...2 x 1.5 mm ² AWG 24...AWG 16 solid Screw terminals, clamping capacity: 2 x 0.25...2 x 0.75 mm ² AWG 24...AWG 18 flexible with cable end |
| Tightening torque | 4.42 lbf.in (0.5 N.m) |
| Overvoltage category | III conforming to EN/IEC 60664-1 |
| Product weight | 0.49 lb(US) (0.22 kg) |

Environment

| | |
|---------------------------------------|---|
| Immunity to microbreaks | <= 1 ms |
| Product certifications | C-Tick CSA GOST GL UL |
| Standards | EN/IEC 61000-4-11 EN/IEC 60068-2-27 Ea EN/IEC 61000-4-2 level 3 EN/IEC 61000-4-4 level 3 EN/IEC 61000-4-3 EN/IEC 60068-2-6 Fc EN/IEC 61000-4-6 level 3 EN/IEC 61000-4-5 EN/IEC 61000-4-12 |
| IP degree of protection | IP20 (terminal block) conforming to IEC 60529 IP40 (front panel) conforming to IEC 60529 |
| Environmental characteristic | EMC directive conforming to EN/IEC 61000-6-2 EMC directive conforming to EN/IEC 61000-6-3 EMC directive conforming to EN/IEC 61000-6-4 EMC directive conforming to EN/IEC 61131-2 zone B Low voltage directive conforming to EN/IEC 61131-2 |
| Disturbance radiated/conducted | Class B conforming to EN 55022-11 group 1 |
| Pollution degree | 2 conforming to EN/IEC 61131-2 |
| Ambient air temperature for operation | -4...104 °F (-20...40 °C) in non-ventilated enclosure conforming to IEC 60068-2-1 and IEC 60068-2-2 -4...131 °F (-20...55 °C) conforming to IEC 60068-2-1 and IEC 60068-2-2 |
| Ambient air temperature for storage | -40...158 °F (-40...70 °C) |
| Operating altitude | 6561.68 ft (2000 m) |

| | |
|--------------------|---|
| Altitude transport | <= 10000 ft (3048 m) |
| Relative humidity | 95 % without condensation or dripping water |

Ordering and shipping details

| | |
|-----------------------|------------------------------|
| Category | 22378 - SR2,3 ZELIO 2 RELAYS |
| Discount Schedule | I |
| GTIN | 00785901693949 |
| Nbr. of units in pkg. | 1 |
| Package weight(Lbs) | 0.2999999999999999 |
| Returnability | Y |
| Country of origin | FR |

Contractual warranty

| | |
|-----------------|-----------|
| Warranty period | 18 months |
|-----------------|-----------|

Compact and Modular Smart Relays

Mounting on 35 mm/1.38 in. DIN Rail

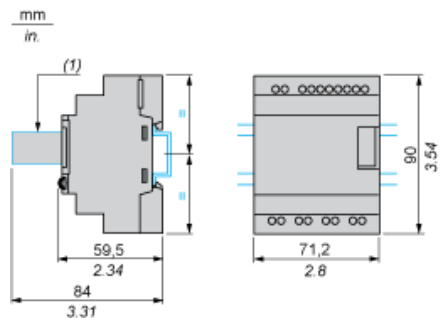

(1) With SR2USB01 or SR2BTC01

Screw Fixing (Retractable Lugs)

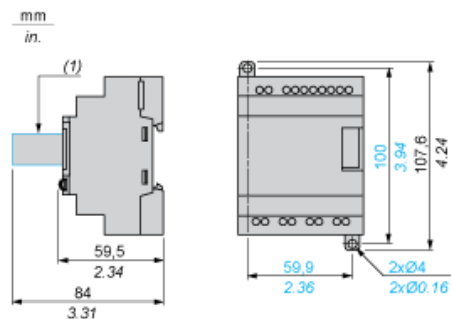

(1) With SR2USB01 or SR2BTC01

Position of Display

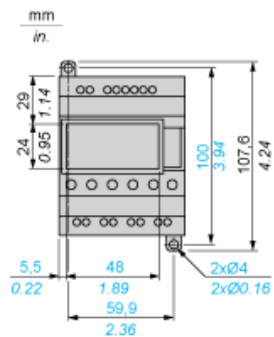

Compact and Modular Smart Relays

Connection of Smart Relays on DC Supply

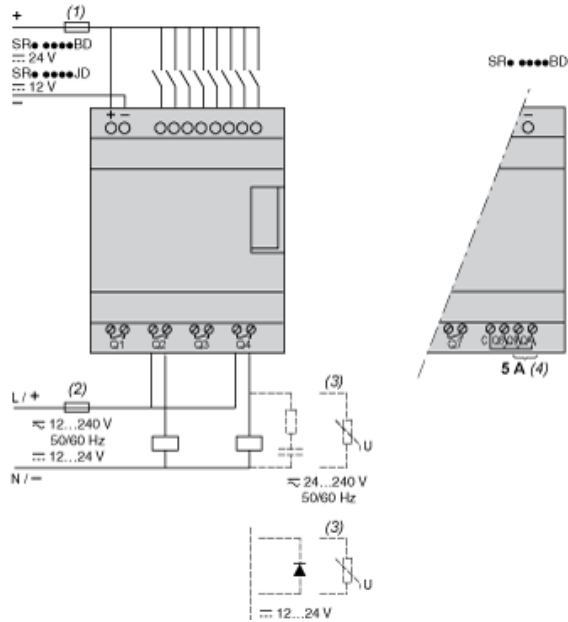

- (1) 1 A quick-blow fuse or circuit-breaker.
- (2) Fuse or circuit-breaker.
- (3) Inductive load.
- (4) Q9 and QA: 5 A (max. current in terminal C: 10 A).

Discrete Input Used for 3-Wire Sensors

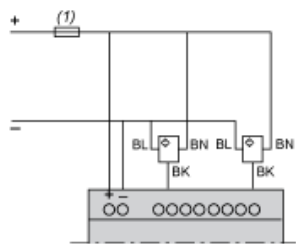

- (1) 1 A quick-blow fuse or circuit-breaker.

Compact and Modular Smart Relays

Electrical Durability of Relay Outputs

(in millions of operating cycles, conforming to IEC/EN 60947-5-1)

DC-12 (1)

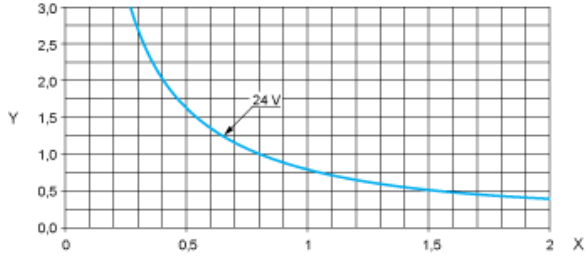

X: Current (A)

Y: Millions of operating cycles

(1) DC-12: control of resistive loads and of solid state loads isolated by opto-coupler, $L/R \leq 1$ ms.

DC-13 (1)

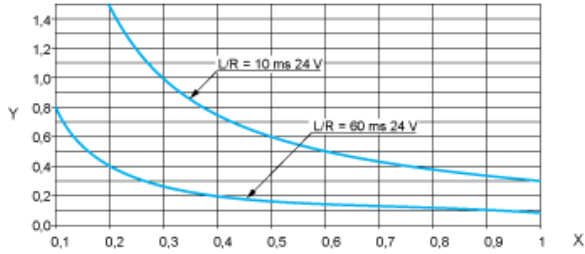

X: Current (A)

Y: Millions of operating cycles

(1) DC-13: switching electromagnets, $L/R \leq 2 \times (U_e \times I_e)$ in ms, U_e : rated operational voltage, I_e : rated operational current (with a protection diode on the load,