



500-15ASQ

15° Angle Brackets for Square Poles

SPECIFICATIONS:

Construction:
Aluminum

Mounting:
Mounting Cleat(s) Included w/ SLP Fixture(s)

500-15SQ16
Overall Height:
5.00" (12.7 cm)

Overall Width:
2.65" (6.73 cm)

Overall Depth:
2.92" (7.42 cm)

500-15SQ21
Overall Height:
5.50" (13.97 cm)

Overall Width:
3.43" (8.71 cm)

Overall Depth:
3.18" (8.08 cm)

Note: Factory Installed Only

Project Information

Job Name

Type 15° Angle Bracket

Catalog Number 500-15ASQ

Approved by

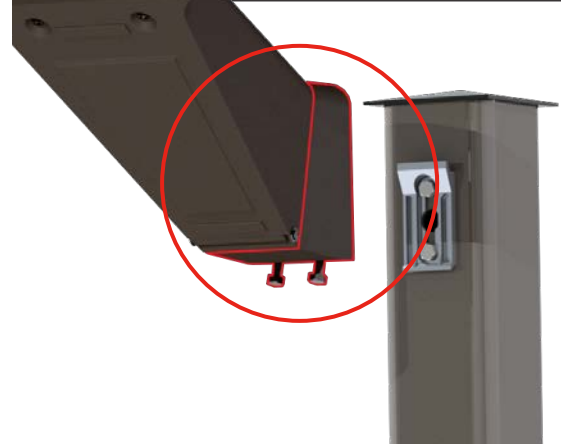

ORDERING INFORMATION:

CATALOG #	DESCRIPTION	FINISH
500-15ASQ16	15° Angle Bracket for SLP 16"	Bronze
500-15ASQ21	15° Angle Bracket for SLP 22"	Bronze

DIMENSIONS:

500-15ASQ16

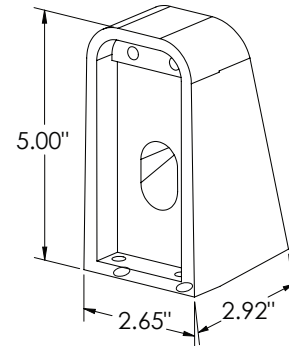

500-15ASQ21

