

B26IC

6" Shallow IC Housing

LAMP WATTAGE: (1) MAXIMUM 75W R/PAR30, 60W A19, 65W BR30

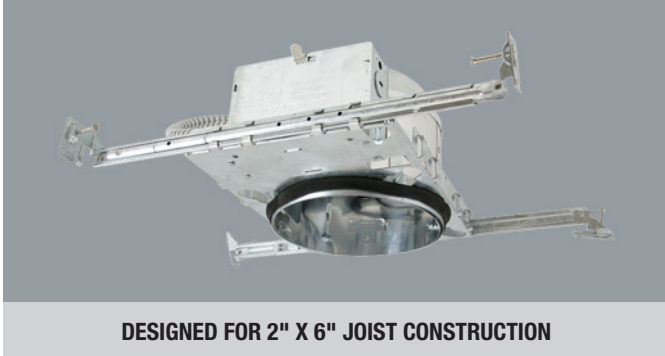

DESIGNED FOR 2" X 6" JOIST CONSTRUCTION

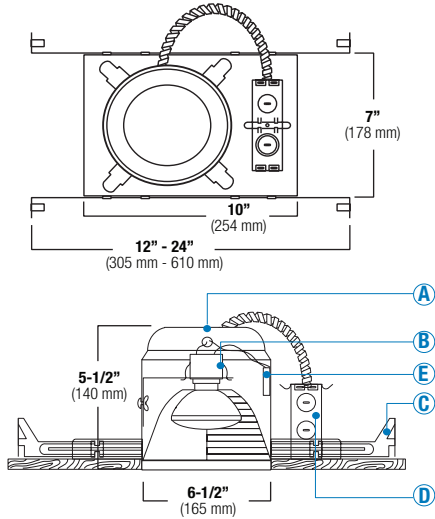

Catalog Number:

Project Name:

Type:

Note:



DESCRIPTION

New construction, thermally protected, IC rated specification grade recessed housing. Accommodates up to 75W PAR30, R30 lamps, 60W A19 lamps and 65W BR30 lamps. Furnished with preinstalled adjustable bar hangers. Junction box is provided with four 1/2" KOs, one 3/4" KO and four Romex knockouts with strain relief.

SPECIFICATION

A. HOUSING - Die-formed all aluminum construction for maximum heat dissipation and rust protection. Adjusts vertically in plaster frame to accommodate 1/2" to 1-3/8" ceiling.

B. SOCKET - Medium base screw shell porcelain socket preinstalled on adjustable mounting bracket is designed to allow usage of different lamp types, as well as proper and consistent lamp positioning.

C. BAR HANGERS - Preinstalled bar hangers allow housing to be positioned and locked at any point within a 24" joist span. They can be positioned on either the long or short axis of the housing and can be shortened for 12" joists. They contain a double-headed real nail for 20° downward angle for better contact, and the 90° pivoting mounting plate makes installation fast and accurate. Bar hangers can fit onto T-Bar spline with additional slots and holes for special mounting methods if necessary.

D. JUNCTION BOX - UL and ETL listed for through-branch circuit wiring, provided with four 1/2" KOs, one 3/4" KO and four Romex knockouts with true pry-out slots and strain clamps.

E. THERMAL PROTECTION - Standard thermal protection device guards against improper installation, overlampping and misuse of insulation material.

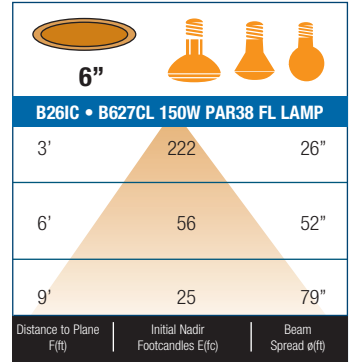

BEAM DIA. MEASURED AT 50% OF NADIR F.C.

FEATURES

- Thermally Protected Shallow IC housing.
- Adjustable socket bracket.
- Wire through junction box.
- Preinstalled adjustable bar hanger.
- Dependable, favorable design and effortless installation.
- 5-1/2" height allows use in 2" x 6" joist construction.
- Special screw on the frame locks bar hangers in place which prevents the housing from any movement once installed.
- Preinstalled socket cap provides electrical contact protection against dust, paint and over spray.

OPTIONS

AIR-SHUT

- Gasket to prevent air flow from heated or air conditioned spaces.
- Meets all national air flow requirements.

UL AND C-UL/ETL AND C-ETL LISTED

- For Damp location
- For Feed-through wiring
- For Direct contact with insulation

ITEM SELECTOR: (Please check the boxes below for the option desired)

TYPE	AIR-SHUT	OPTION	TRIM TYPE	BAFFLE	REFLECTOR	TRIM/RING	GLASS
B26IC	<input type="checkbox"/> AT	<input type="checkbox"/> (W) With quick connects	<input type="checkbox"/> B630 <input type="checkbox"/> B616 <input type="checkbox"/> B642 <input type="checkbox"/> B648 <input type="checkbox"/> B644 <input type="checkbox"/> B620 <input type="checkbox"/> B663 <input type="checkbox"/> B641 <input type="checkbox"/> B652 <input type="checkbox"/> B650 <input type="checkbox"/> B631 <input type="checkbox"/> B673 <input type="checkbox"/> B656 <input type="checkbox"/> B603 <input type="checkbox"/> B622 <input type="checkbox"/> AF637 <input type="checkbox"/> B683 <input type="checkbox"/> B657 <input type="checkbox"/> B615 <input type="checkbox"/> B681 <input type="checkbox"/> AF631 <input type="checkbox"/> B601 <input type="checkbox"/> B637 <input type="checkbox"/> B633 <input type="checkbox"/> B687 <input type="checkbox"/> AF639 <input type="checkbox"/> B601L <input type="checkbox"/> B643 <input type="checkbox"/> B649 <input type="checkbox"/> B682 <input type="checkbox"/> B607 <input type="checkbox"/> B605 <input type="checkbox"/> B658 <input type="checkbox"/> AF633 <input type="checkbox"/> B693 <input type="checkbox"/> B617 <input type="checkbox"/> B605L <input type="checkbox"/> B659 <input type="checkbox"/> B225 <input type="checkbox"/> B688 <input type="checkbox"/> B602 <input type="checkbox"/> B606 <input type="checkbox"/> B675 <input type="checkbox"/> B653 <input type="checkbox"/> B685 <input type="checkbox"/> B609 <input type="checkbox"/> B606L <input type="checkbox"/> B676 <input type="checkbox"/> B651 <input type="checkbox"/> B696 <input type="checkbox"/> B619 <input type="checkbox"/> B635 <input type="checkbox"/> B612 <input type="checkbox"/> B611 <input type="checkbox"/> B689 <input type="checkbox"/> B646 <input type="checkbox"/> B636 <input type="checkbox"/> B645 <input type="checkbox"/> B647 <input type="checkbox"/> B680	<input type="checkbox"/> W <input type="checkbox"/> CL <input type="checkbox"/> WH <input type="checkbox"/> P <input type="checkbox"/> RG <input type="checkbox"/> BK <input type="checkbox"/> SN <input type="checkbox"/> W <input type="checkbox"/> SN <input type="checkbox"/> CP <input type="checkbox"/> MB <input type="checkbox"/> CP <input type="checkbox"/> BZ <input type="checkbox"/> BZ <input type="checkbox"/> CH <input type="checkbox"/> CP <input type="checkbox"/> PB <input type="checkbox"/> PB <input type="checkbox"/> SN <input type="checkbox"/> BZ <input type="checkbox"/> BZ <input type="checkbox"/> SHZ	<input type="checkbox"/> Green <input type="checkbox"/> Yellow <input type="checkbox"/> Pink <input type="checkbox"/> Brown <input type="checkbox"/> Navy Blue <input type="checkbox"/> Orange <input type="checkbox"/> Blue <input type="checkbox"/> White <input type="checkbox"/> Red		

Specifications:

B26IC



BAFFLE	REFLECTOR	TRIM/RING
W White	CL Chrome	WH White
P Black	RG Gold	BK Black
SN Satin Nickel	W White	SN Satin Nickel
CP Copper	MB Black	CP Copper
BZ Bronze	BZ Bronze	CH Chrome
	CP Copper	PB Polish Brass
	SN Satin Nickel	BZ Bronze
	SHZ Satin Haze	

Sample of Catalog Number: B26IC-AT-W-B630-W-WH

*For custom baffle, reflector, trim ring, glass color and lens options, please consult factory.



Submittal form is available @ www.iuseelite.com
Tel: 323-888-1973 • Fax: 323-888-1977

Specifications and Dimensions subject to change without notice.

REV: ELITE LIGHTING-SPEC-06-29-2011