

Schedule 40 / Schedule 80 Fittings & Accessories

Standard UL Coupling

Part Number	Trade Size	Carton Qty.	"W"	"L"	"ID"	"D"
6141623	1/2	200	1.063	1.500	.875	.625
6141624	3/4	125	1.313	1.563	1.063	.625
6141625	1	70	1.625	2.000	1.313	1.000
6141626	1-1/4	40	2.000	2.125	1.688	1.000
6141627	1-1/2	30	2.250	2.375	1.938	1.063
6141628	2	40	2.688	2.438	2.375	1.250
6141629	2-1/2	20	3.250	3.500	2.875	1.750
6141630	3	40	4.000	3.875	3.500	1.188
6141631	3-1/2	30	4.1250	4.000	4.000	1.938
6141632	4	20	5.000	4.188	4.500	2.000
6141633	5	10	6.125	5.375	5.625	2.500
6141634	6	8	7.250	6.375	6.625	3.000
* 6141635D	8	1	--	--	--	--

* Not UL Listed

Dimensions are nominal

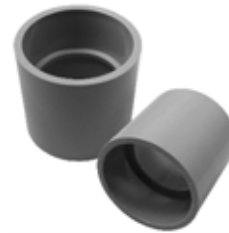

A connector used to join lengths of conduit pipe. The fitting consists of two solvent weld female ends with a center stop. Both pieces of pipe should seat at the stop for proper positioning.

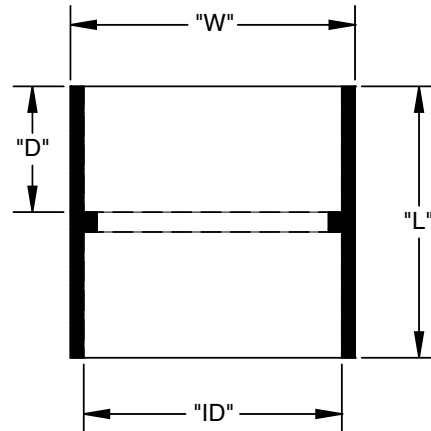

Female Adapter

Part Number	Trade Size	Carton Qty.	"W"	"L"	"D"
5140043	1/2	200	1.000	1.438	.688
5140044	3/4	125	1.250	1.625	.688
5140045	1	70	1.563	1.875	.875
5140046	1-1/4	40	2.000	1.938	.938
5140047	1-1/2	30	2.250	2.125	.938
5140048	2	40	2.688	2.125	.938
5140049	2-1/2	20	3.313	3.000	1.313
5140050	3	40	4.000	3.063	1.250
5140051	3-1/2	30	4.500	3.000	1.188
5140052	4	20	5.000	3.250	1.375
5140053	5	10	6.125	3.688	1.313
5140054	6	8	7.250	4.375	1.625
* 5140055D	8	2	9.313	7.000	2.250

* Not UL Listed

Dimensions are nominal



A connector often used to transition threaded metal conduit to PVC conduit. It can also be used to join PVC to PVC. The fittings consist of two female ends. One end is threaded and the other is solvent weld. Both ends will fit the same diameter conduit.

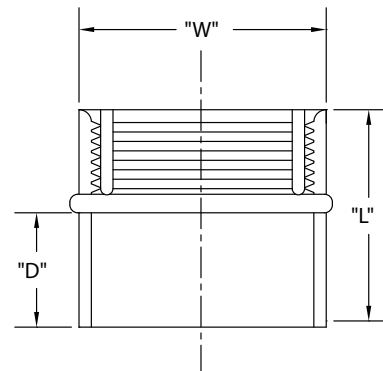

Fittings for Type EB & DB Duct

Female Adapter

Part Number	Trade Size	Carton Qty.	"W"	"L"	"D"
5140043	1/2	200	1.000	1.438	.688
5140044	3/4	125	1.250	1.625	.688
5140045	1	70	1.563	1.875	.875
5140046	1-1/4	40	2.000	1.938	.938
5140047	1-1/2	30	2.250	2.125	.938
5140048	2	40	2.688	2.125	.938
5140049	2-1/2	20	3.313	3.000	1.313
5140050	3	40	4.000	3.063	1.250
5140051	3-1/2	30	4.500	3.000	1.188
5140052	4	20	5.000	3.250	1.375
5140053	5	10	6.125	3.688	1.313
5140054	6	8	7.250	4.375	1.625
* 5140055D	8	2	9.313	7.000	2.250

* Not UL Listed

Dimensions are nominal



A connector often used to transition threaded metal conduit to PVC conduit. It can also be used to join PVC to PVC. The fittings consist of two female ends. One end is threaded and the other is solvent weld. Both ends will fit the same diameter conduit.

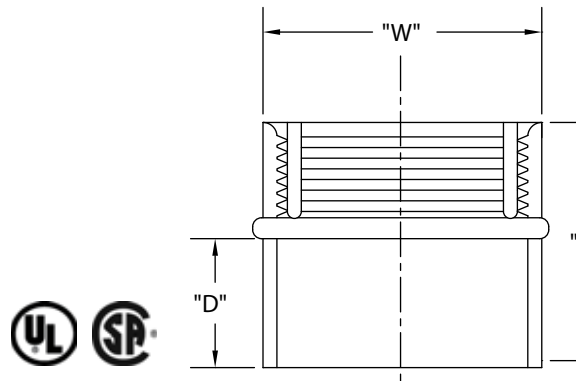

TC-6 Longline Coupling with No Center Stop - Fabricated

Part Number	Trade Size	Carton Qty.	"DIA"	"A"
6121622	1-1/2	30	1.921	5.00
6121623	2	20	2.400	6.00
6121625	3	25	3.538	6.00
6121626	4	15	4.544	6.75
6121627	5	8	5.614	7.00
6121635	6	4	6.687	7.25

Dimensions are nominal

