

This section offers a full selection of fittings and accessories to complete our strut system. Fittings are made from hot rolled, pickled and oiled plate or strip steel in accordance with ASTM A1018 33,000 PSI min. yield, unless noted.

Dimensions

The following dimensions apply to all fittings except as noted:

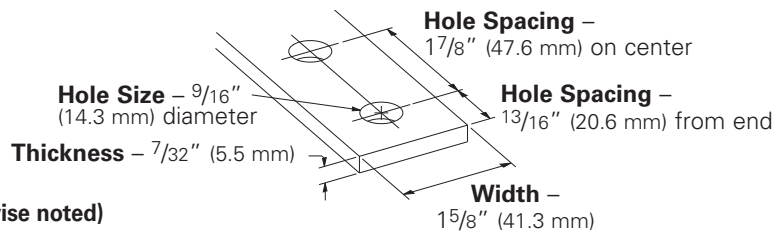

Materials & Finishes (Unless otherwise noted)

Finish Code	Finish	Specification
PLN	Plain	ASTM A1018 33,000 PSI min. yield
ZN	Electro-Plated Zinc	ASTM B633 SC3 Type III or ASTM A653
GRN	DURA GREEN™	
HDG	Hot-Dipped Galvanized	ASTM A123
SS4	Stainless Steel Type 304	ASTM A240
SS6	Stainless Steel Type 316	ASTM A240
AL	Aluminum	ASTM B209

Note: A minimum order may apply on special material and finishes.

Hardware

Nuts and bolts are not included with the fittings and must be ordered separately, unless noted.

Pre-Assembled Fittings

Some fittings are available with hex head cap screws and channel nuts pre-assembled.

These fittings and finishes will be flagged using the following symbol.



PA ^{ZN}
GRN

Metric

Metric dimensions are shown in parentheses. Unless noted, all metric dimensions are in millimeters.

Load Data

The load data published includes safety factor of 2.5 when used with 12 ga. (2.6) channel safety factor = ratio of ultimate load to the design load).

Use 1/2"-13 x 7/8" hex head cap screws and 1/2"-13 (N225 or TN225) channel nuts for the rated results.

Note: See page 277 Design Load Data for typical channel - fitting connections.

Recommended Bolt Torque

Bolt Size	1/4"-20	5/16"-18	3/8"-16	1/2"-13
Foot/Lbs.	6	11	19	50
Nm	8	15	26	68

See chart on page 154 for setscrew torque.

4Dimension™ Strut System Compatible

These fittings and finishes will be flagged using the following symbol.



'Z' & Wing Fittings

B515 Adjustable Offset Gusseted Z-Support

- Standard finishes: ZN, GRN
- Wt./C 93 Lbs. (42.2 kg)

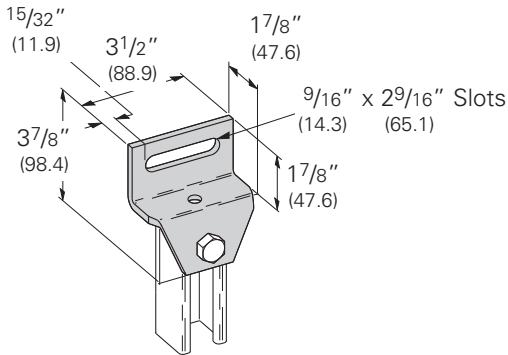

B428 Eight Hole Gusseted Corner Connection

- Standard finishes: ZN, GRN
- Wt./C 203 Lbs. (92.1 kg)

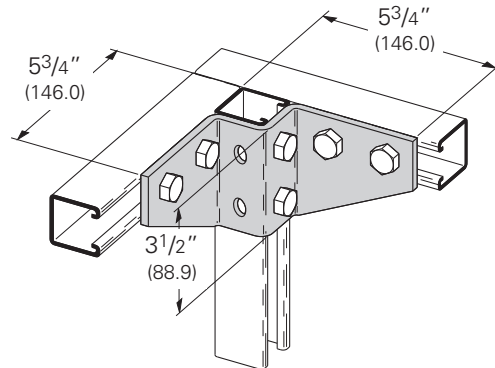

B267R Three Hole Single Corner Connection (Right Hand)

- Standard finishes: ZN, GRN
- Wt./C 54 Lbs. (24.5 kg)

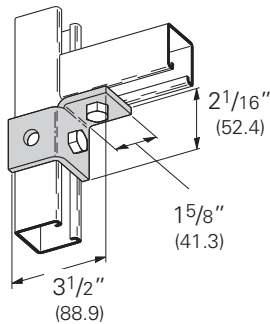

B267L Three Hole Single Corner Connection (Left Hand)

- Standard finishes: ZN, GRN
- Wt./C 54 Lbs. (24.5 kg)

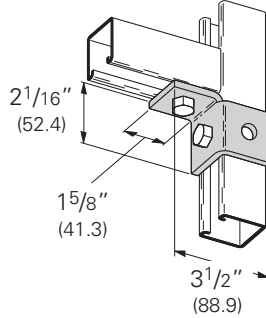

B270R Four Hole Single Corner Connection (Right Hand)

- Standard finishes: ZN, GRN
- Wt./C 77 Lbs. (34.9 kg)

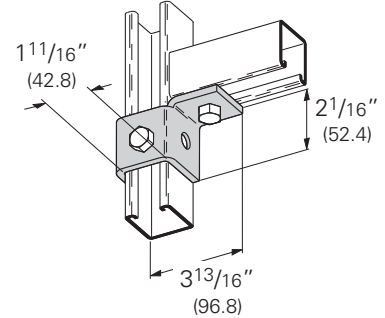

B270L Four Hole Single Corner Connection (Left Hand)

- Standard finishes: ZN, GRN
- Wt./C 77 Lbs. (34.9 kg)

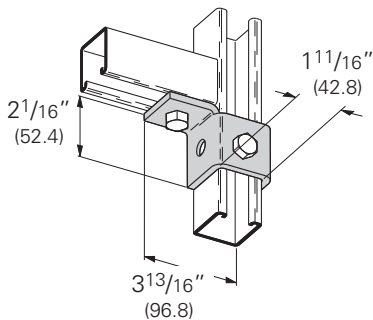

B268R Five Hole Single Corner Connection (Right Hand)

- Standard finishes: ZN, GRN
- Wt./C 100 Lbs. (45.3 kg)

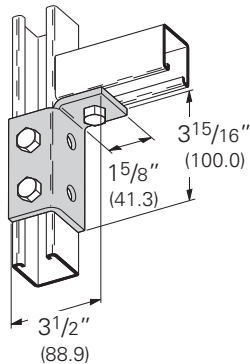

B268L Five Hole Single Corner Connection (Left Hand)

- Standard finishes: ZN, GRN
- Wt./C 100 Lbs. (45.3 kg)

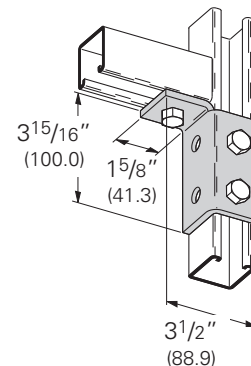

Reference page 106 for general fitting and standard finish specifications.