

Typical Hole Pattern
& Splice Plate

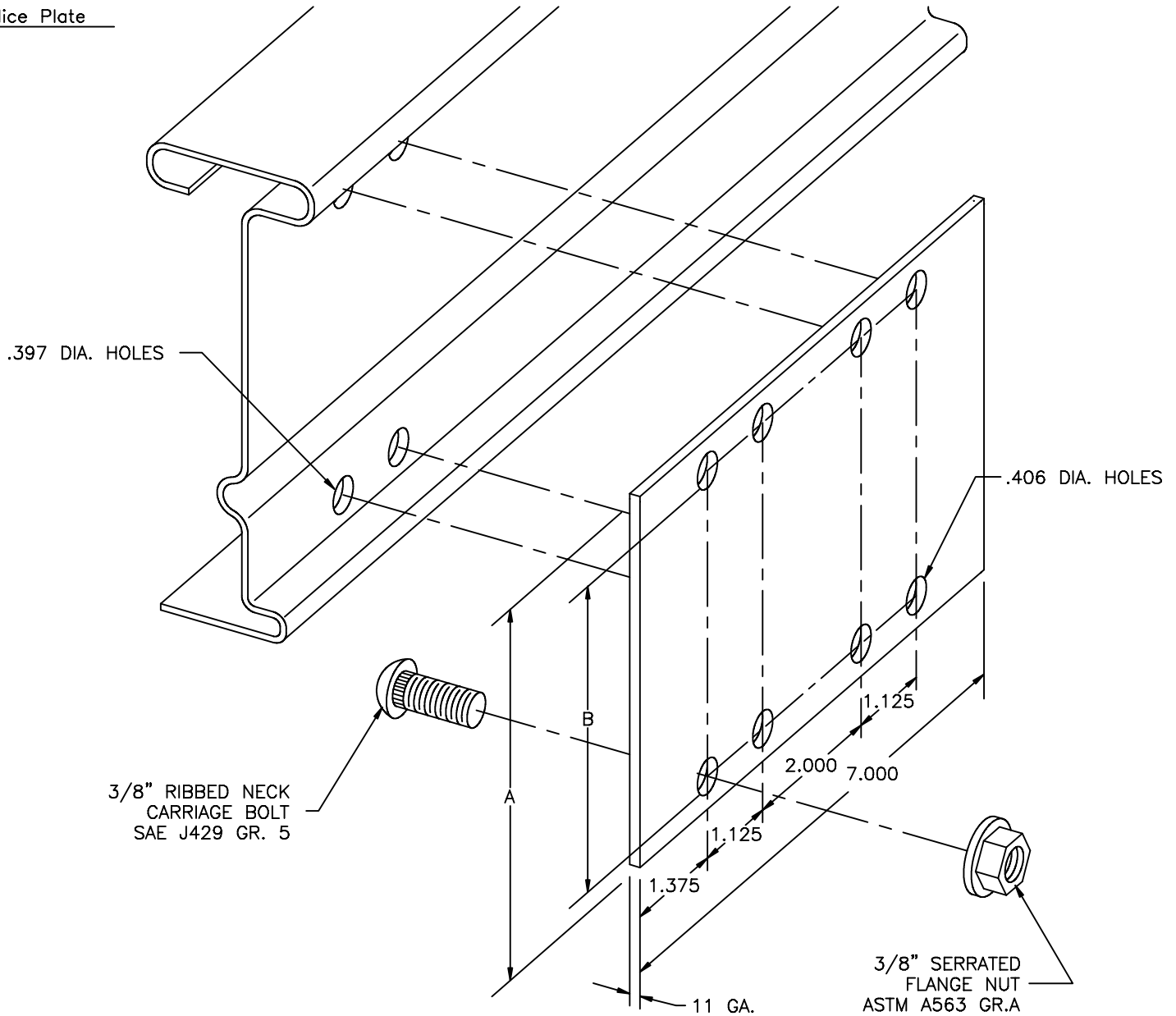

CAT. NO.	TRAY DEPTH	A	B
9*8004	4	3.360	2.594
9*8005	5	4.360	3.594
9*8006	6	5.360	4.594
9*8007	7	6.360	5.594

* = INSERT ZN FOR ZINC PLATED
G FOR HOT DIP GALV. AFTER FAB.
SS4 FOR STAINLESS STEEL 304
SS6 FOR STAINLESS STEEL 316

MATERIAL: PLATE-ASTM A607 GR. 50
BOLT- SAE J429 GR. 5
NUT- ASTM A563 GR. A
FINISHES: PLATE- ASTM A123 (HDGAF) OR
B633 SC1 (ZINC PLATED)
BOLT, NUT, & WASHER- ASTM B633 SC1 OR
STAINLESS STEEL TYPE 316

COOPER B-Line

509 WEST MONROE STREET
HIGHLAND, ILLINOIS 62249
PHONE (618)-654-2184

TITLE:
Typical Hole Pattern
& Splice Plate

EQUIPMENT FURNISHED HAS BEEN FABRICATED
IN ACCORDANCE WITH THIS DRAWING.

PRODUCT DWG. NO'S:

3928

SHEET OF
DRAWN BY:
BJW

DRAWING NO.
S3928

DATE:
9/9/97