

Fittings

This section offers a full selection of fittings and accessories to complete our strut system. Fittings are made from hot rolled, pickled and oiled plate or strip steel in accordance with ASTM A1018 33,000 PSI min. yield, unless noted.

Dimensions

The following dimensions apply to all fittings except as noted:

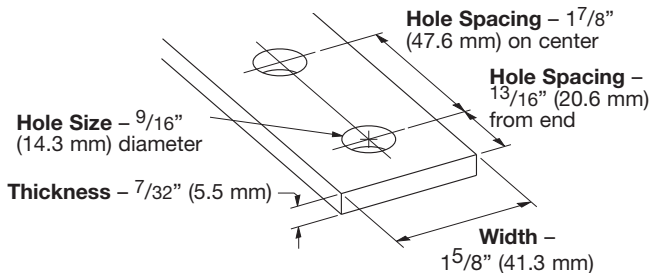

Materials & Finishes (Unless otherwise noted)

Finish Code	Finish	Specification
PLN	Plain	ASTM A1018 33,000 PSI min. yield
ZN	Electro-Plated Zinc	ASTM B633 SC3 Type III or ASTM A653
GRN	DURA-GREEN™	
HDG	Hot-Dipped Galvanized	ASTM A123
SS4	Stainless Steel Type 304	ASTM A240
SS6	Stainless Steel Type 316	ASTM A240
AL	Aluminum	ASTM B209

Note: A minimum order may apply on special material and finishes.

Load Data

The load data published includes safety factor of 2.5 when used with 12 ga. (2.6) channel (safety factor = ratio of ultimate load to the design load).

Use $\frac{1}{2}$ "-13 x $\frac{7}{8}$ " hex head cap screws and $\frac{1}{2}$ "-13 (N225 or TN225) channel nuts for the rated results.

Recommended Bolt Torque

Bolt Size	$\frac{1}{4}$ "-20	$\frac{5}{16}$ "-18	$\frac{3}{8}$ "-16	$\frac{1}{2}$ "-13
Foot/Lbs.	6	11	19	50
Nm	8	15	26	68

See chart on page 112 for setscrew torque.

Hardware

Nuts and bolts are not included with the fittings and must be ordered separately, unless noted.

Pre-Assembled Fittings

Some fittings are available with hex head cap screws and channel nuts pre-assembled. These fittings and finishes will be flagged using the following symbol.



Metric

Metric dimensions are shown in parentheses. Unless noted, all metric dimensions are in millimeters.



B292 20¹/₂" (520.7) BRACKET

- Uniform Loading 600 Lbs. (2.67 kN)
- Safety Factor of 2.5
- Standard finishes: ZN, GRN, HDG, SS4
- Wt./C 490 Lbs. (222.2 kg)

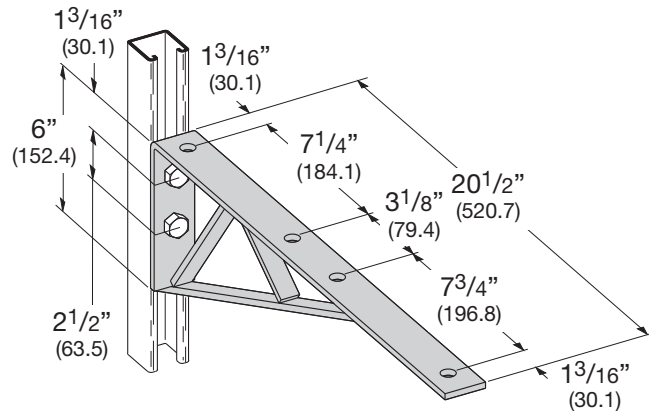

B297 DOUBLE CHANNEL BRACKET

- Safety Factor of 2.5
- Standard finishes: ZN, GRN, HDG

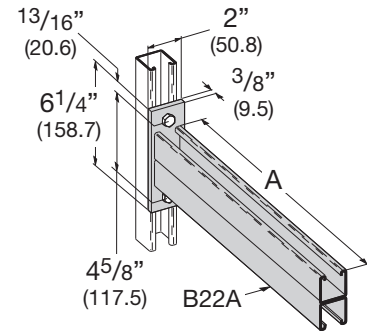

Part No.	A	Uniform Load		Wt./C	
		Lbs.	kN	Lbs.	kg
B297-12	12" (304.8)	1660	(7.37)	485	(220.0)
B297-18	18" (457.2)	1100	(4.88)	668	(303.0)
B297-24	24" (609.6)	835	(3.71)	857	(388.7)
B297-30	30" (762.0)	665	(2.95)	1040	(471.7)
B297-36	36" (914.4)	550	(2.44)	1240	(562.4)
B297-42	42" (1066.8)	465	(2.06)	1440	(653.2)

B409 SINGLE CHANNEL BRACKET

- Safety Factor of 2.5
- Standard finishes: ZN, GRN, SS4

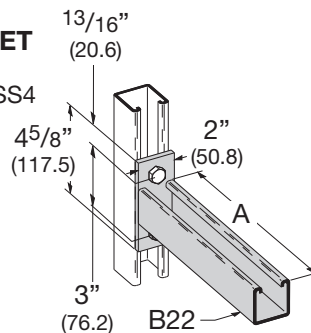

Part No.	A	Uniform Load		Wt./C	
		Lbs.	kN	Lbs.	kg
B409-6	6" (152.4)	1920	(8.54)	152	(68.9)
B409-9	9" (228.6)	1280	(5.69)	195	(88.4)
B409-12	12" (304.8)	960	(4.27)	232	(105.2)
B409-14	14" (355.6)	800	(3.56)	274	(124.3)
B409-16	16" (406.4)	730	(3.25)	314	(142.4)
B409-18	18" (457.2)	640	(2.84)	347	(157.4)
B409-24	24" (609.6)	480	(2.13)	450	(204.1)

B494 BRACED SINGLE BRACKET

- Safety Factor of 2.5
- Standard finishes: ZN, GRN

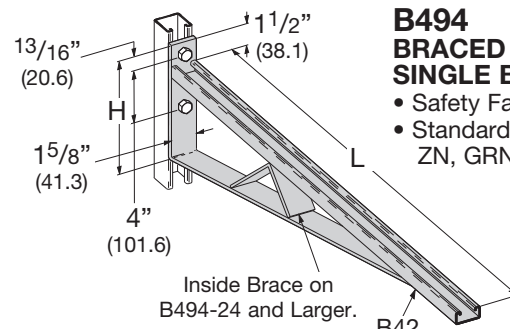

Part No.	L	H	Uniform Load		Wt. /C	
			Lbs.	kN	Lbs.	kg
B494-12	12" (304.8)	8 ³ / ₄ " (222.2)	1580	(7.02)	364	(165.1)
B494-18	18" (475.2)	8 ³ / ₄ " (222.2)	1000	(4.45)	479	(217.3)
B494-24	24" (609.6)	8 ³ / ₄ " (222.2)	996	(4.43)	716	(324.8)
B494-30	30" (762.0)	11 ¹ / ₄ " (285.7)	924	(4.11)	927	(420.5)
B494-36	36" (914.4)	11 ¹ / ₄ " (285.7)	864	(3.84)	1095	(496.7)
B494-42	42" (1066.8)	16" (406.4)	580	(2.58)	1400	(635.0)
B494-48	48" (1219.2)	16" (406.4)	500	(2.22)	1510	(684.9)

B174SH-B186SH L&R SLOTTED BRACKET

- Safety Factor of 2.5
- Specify L for left or R for right bracing
- Material: ASTM A1011 33,000 PSI min. yield
- Standard finishes: ZN, GRN

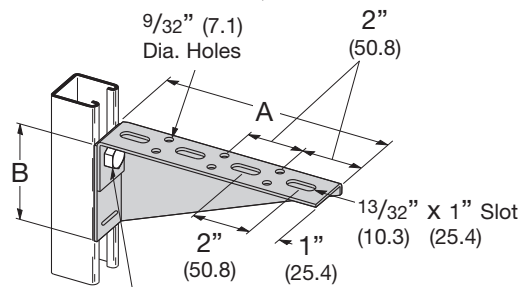

Mounting Hole
7/16" (11.1) Dia.

Right bracket shown, left bracket
gusset on opposite side.

Part No.	A	B	Uniform Load		Wt./C	
			Lbs.	kN	Lbs.	kg
B174SH	24" (609.6)	6 ⁷ / ₁₆ " (163.5)	225	(1.00)	370	(167.8)
B175SH	26" (660.4)	6 ¹⁵ / ₁₆ " (176.2)	225	(1.00)	425	(192.8)
B176SH	28" (711.2)	7 ⁷ / ₁₆ " (188.9)	225	(1.00)	480	(217.7)
B177SH	30" (762.0)	7 ¹⁵ / ₁₆ " (201.6)	225	(1.00)	520	(235.9)
B178SH	12" (304.8)	3 ⁷ / ₁₆ " (87.3)	350	(1.55)	143	(64.8)
B179SH	14" (355.6)	3 ¹⁵ / ₁₆ " (100.0)	350	(1.55)	162	(73.5)
B180SH	16" (406.4)	4 ⁷ / ₁₆ " (112.7)	250	(1.11)	204	(92.5)
B181SH	18" (457.2)	4 ¹⁵ / ₁₆ " (125.4)	250	(1.11)	232	(105.2)
B182SH	20" (508.0)	5 ⁷ / ₁₆ " (138.1)	250	(1.11)	275	(124.7)
B183SH	22" (558.8)	5 ¹⁵ / ₁₆ " (150.8)	250	(1.11)	317	(143.8)
B184SH	6" (152.4)	1 ¹⁵ / ₁₆ " (49.2)	225	(1.00)	58	(26.3)
B185SH	8" (203.2)	2 ⁷ / ₁₆ " (61.9)	225	(1.00)	82	(37.2)
B186SH	10" (254.0)	2 ¹⁵ / ₁₆ " (74.6)	325	(1.44)	103	(46.7)

Reference page 72 for general fitting and standard finish specifications.

General Notes for Strut-Type Channel Raceway

UL Category RIUU - B-Line, Inc., Highland, IL 62249 December 11, 1998 (C)
 FLUORESCENT AND INCANDESCENT LIGHTING



Suitable for not more than the number of wires of the sizes and types indicated in the following tables. Intended to enclose circuits operating at potentials not exceeding 600 volts between conductors. In all cases, the B217-20 or B217P snap-in cover is required to complete raceway closure. When using B217-24 snap-in cover, the number of wires is limited to 7 or fewer conductors no larger than #12 AWG.

B-Line's strut-type channel raceways and fittings are manufactured and tested to comply with the UL Standard for Safety for Strut-Type Channel Raceways and Fittings (UL 5B) in accordance with Article 384 of the 2002 National Electrical Code, NFPA 70.

1. Support spans for strut-type channel raceway shall not exceed 10 foot intervals.
2. No conductor larger than that for which the raceway is listed shall be installed in strut-type channel raceways. No wires under 14AWG or over 6AWG are allowed in any of B-Line's strut-type channel raceway. See tables 1, 2 and 3 below for a listing of the approved conductors for B-Line's strut-type channel raceways.
3. The number of conductors permitted in strut-type channel raceway shall not exceed the percentage fill using Table 384-22 and the applicable outside diameter of specific types and sizes of wire given in the tables in chapter 9 of the National Electrical Code. Table 384-22 lists two different percent fill areas depending on the use of internal or external joiners. Use 40% area fill with external joiners and 25% area fill for internal joiners.
4. Items in the electrical section of the B-Line Strut Systems Catalog identified by the UL symbol provide for electrical continuity. Other items require the use of a separate grounding wire.
5. If strut-type channel raceway is connected to another wiring system, the raceway must be field-tapped adjacent to the wire entry point to accept a #10-32 or larger grounding screw. A plated or stainless steel screw may be used. A sheet metal screw is not acceptable. Drill and tap the grounding wire hole before installing wires in raceway or move installed wires out of the way to avoid damage. After drilling and tapping, remove metal chips and burrs before installing screw.

TABLE 1: MAXIMUM NUMBER OF WIRES (Adjusted per NEC Table 384.22 for 40% fill)

Use this table to determine the type and number of conductors for use with B-Line's strut-type channel raceway using external joiners. This table applies for all installations except for the support and supply of electric discharge type lighting fixtures. See table 2 and 3 for further information.

Insulation Type	Wire Size AWG.	B11 B11K06	B12 B12K06	B22 B22K06	B24 B24K06	B26 B26K06	B32 B32K06	B56 B56K06
FEP, FEPB	14	172	127	81	81	81	67	36
	12	126	92	59	59	59	49	26
	10	90	66	42	42	42	35	19
	8	51	38	24	24	24	20	11
	6	24	17	11	12	12	9	5
RH, RHH, RHW	14	52	38	24	26	27	20	12
	12	45	33	21	22	23	17	10
	10	37	27	17	18	19	14	8
	8	20	14	9	10	10	7	4
	6	14	10	6	7	7	5	3
T, TW	14	124	91	58	58	58	48	26
	12	95	70	45	45	45	37	20
	10	69	51	33	33	33	27	14
	8	36	26	17	18	19	14	8
	6	21	15	9	10	11	8	5
THHN, THWN	14	178	131	84	84	84	69	37
	12	130	95	61	61	61	50	27
	10	82	60	38	38	38	32	17
	8	46	34	21	22	22	17	10
	6	33	24	15	16	16	12	7
THW	14	82	61	39	39	39	32	17
	12	66	49	31	31	31	26	14
	10	52	38	24	24	24	20	11
	8	29	21	13	14	15	11	6
	6	21	15	10	10	11	8	5
XHHW	14	124	91	58	58	58	48	26
	12	95	70	45	45	45	37	20
	10	71	52	33	33	33	28	15
	8	37	27	17	19	19	14	8
	6	27	20	13	14	14	10	6