

Metal Framing Channels

Channel

Metal framing channel is cold formed on our modern rolling mills from 12 Ga. (2.6mm), 14 Ga. (1.9mm), and 16 Ga. (1.5mm) low carbon steel strips. A continuous slot with turned lips provides the ability to make attachments at any point.

Lengths & Tolerances

All channels excluding 'SH' style
 $\pm 1/8"$ (3.2mm) on 10' (3.05m) and
 $\pm 3/16"$ (4.76mm) on 20' (6.09m)

All 'SH' channels only
 $\pm 1/4"$ (6.35mm) on 10' (3.05m) and
 $\pm 1/2"$ (12.70mm) on 20' (6.09m)

Custom lengths are available upon request.

Slots

Slotted series of channels offer full flexibility. A variety of pre-punched slot patterns eliminate the need for precise field measuring for hole locations. Slots offer wide adjustments in the alignment and bolt sizing.

Holes

A variety of pre-punched $9/16"$ (14.3 mm) diameter hole patterns are available in our channels. These hole patterns provide an economical alternative to costly field drilling required for many applications.

Knockouts

When used with series B217-20 Closure Strips, knockout channels can be used to provide an economical U.L. listed surface raceway. Channels are furnished with $7/8"$ (22.2 mm) knockouts on 6" (152 mm) centers, allowing for perfect fixture alignment on spans up to 20' (6.09 m).

Materials & Finishes (Unless otherwise noted)

Steel: Plain & Pre-galvanized

12 Ga. (2.6), 14 Ga. (1.9) and 16 Ga. (1.5)

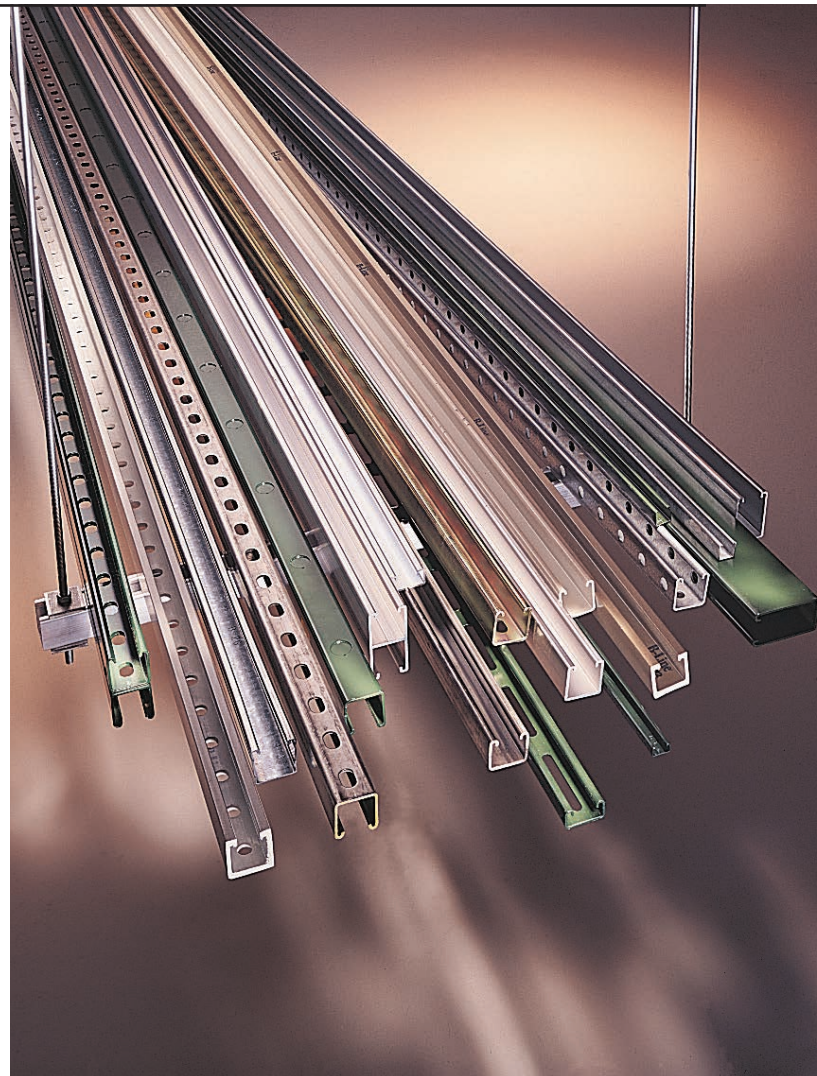

Channel & Combinations

Finish Code	Finish	Specification
PLN	Plain	ASTM A1011, 33,000 PSI min. yield
GRN	DURA-GREEN™	
GLV	Pre-Galvanized	ASTM A653 33,000 PSI min. yield
HDG	Hot-Dipped Galvanized	ASTM A123
YZN	Yellow Zinc Chromate	ASTM B633 SC3 Type II
SS4	Stainless Steel Type 304	ASTM A240
SS6	Stainless Steel Type 316	ASTM A240
AL	Aluminum	Aluminum 6063-T6

Note: A minimum order may apply on special material and finishes.

Design Load (Steel & Stainless Steel)

The design loads given for strut beam loads are based on a simple beam condition using an allowable stress of 25,000 psi. This allowable stress results in a safety factor of 1.68. This is based upon virgin steel minimum yield strength of 33,000 psi cold worked during rolling to an average yield stress of 42,000 psi. For aluminum channel loading multiply steel loading by a factor of 0.38.

Welding

Weld spacing is maintained between 2 $1/2$ inches (63.5 mm) and 4 inches (101.6 mm) on center. Through high quality control testing of welded channels and continuous monitoring of welding equipment, B-Line provides the most consistent combination channels available today.

Metric

Metric dimensions are shown in parentheses. Unless noted, all metric dimensions are in millimeters.

SELECTION CHART

for Channels, Materials and Hole Patterns

Channel Type	Channel Dimensions				Material & Thickness *				Channel Hole Pattern **				
					Stainless Steel				SH 9/16" x 1 1/8" slots on 2" centers	S 13/32" x 3" slots	H17/8 9/16" diameter holes	TH 9/16" diameter on 1 7/8" centers	KO6 7/8" diameter knockouts
	Steel	Alum.	Type 304	Type 316									
Height	Width			<u>1</u>	<u>2</u>	<u>3</u>	<u>4</u>						
B11	3 1/4"	(82.5)	1 5/8"	(41.3)	12 Ga.	.105	-	-	<u>1</u>	<u>1</u>	<u>1</u>	-	<u>1</u>
B12	2 7/16"	(61.9)	1 5/8"	(41.3)	12 Ga.	.105	-	-	<u>1 2</u>	<u>1</u>	<u>1 2</u>	-	<u>1 2</u>
B22	1 5/8"	(41.3)	1 5/8"	(41.3)	12 Ga.	.105	12 Ga.	12 Ga.	<u>1 2 3 4</u>	<u>1 3</u>	<u>1 2 3</u>	<u>1</u>	<u>1 2</u>
B24	1 5/8"	(41.3)	1 5/8"	(41.3)	14 Ga.	.080	14 Ga.	14 Ga.	<u>1 2 3 4</u>	<u>1</u>	<u>1 2 3</u>	-	<u>1 2</u>
B26	1 5/8"	(41.3)	1 5/8"	(41.3)	16 Ga.	-	-	-	<u>1</u>	<u>1</u>	<u>1</u>	-	<u>1</u>
B32	1 3/8"	(34.9)	1 5/8"	(41.3)	12 Ga.	-	12 Ga.	-	<u>1 3</u>	<u>1</u>	<u>1 3</u>	-	<u>1</u>
B42	1"	(25.4)	1 5/8"	(41.3)	12 Ga.	-	12 Ga.	-	<u>1 3</u>	<u>1</u>	<u>1 3</u>	-	<u>1</u>
B52	1 3/16"	(20.6)	1 5/8"	(41.3)	12 Ga.	-	12 Ga.	12 Ga.	<u>1 3 4</u>	<u>1</u>	<u>1</u>	-	<u>1</u>
B54	1 3/16"	(20.6)	1 5/8"	(41.3)	14 Ga.	.080	14 Ga.	14 Ga.	<u>1 2 3 4</u>	<u>1</u>	<u>1 2 3 4</u>	-	<u>1 2</u>
B56	1 3/16"	(20.6)	1 5/8"	(41.3)	16 Ga.	-	-	-	<u>1</u>	<u>1</u>	<u>1</u>	-	<u>1</u>
B62	1 3/16"	(20.6)	1 3/16"	(20.6)	18 Ga.	-	-	-	-	-	-	-	-
B72	1 3/32"	(10.3)	1 3/16"	(20.6)	18 Ga.	-	-	-	-	-	-	-	-

The selection has been prepared to provide a reference for available channel, materials and hole patterns. Material types available for various hole patterns are defined by numbers 1 thru 4.
Some stainless steel channels with hole patterns are available on special order only.

*Metric equivalent for thicknesses shown in chart. **1 - Steel
 12 Ga. = 2.6 mm 18 Ga. = 1.2 mm 2 - Aluminum
 14 Ga. = 1.9 mm .105 = 2.6 mm 3 - Type 304 Stainless Steel
 16 Ga. = 1.5 mm .080 = 2.0 mm 4 - Type 316 Stainless Steel

Properties may vary due to commercial tolerances of the material.

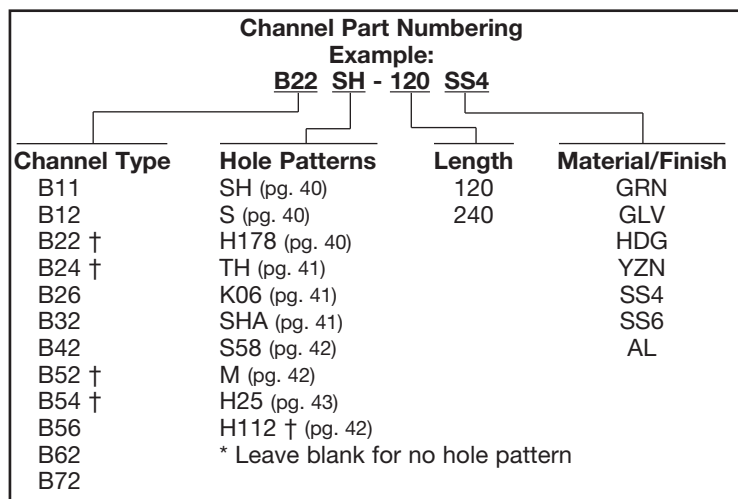

Reference page 14 for general fitting and standard finish specifications.

Mini Channel & Fittings

Our mini channels and fittings provide for an economical method of supporting light load requirements on a metal framing system.

Channel

Channels are cold formed on our modern rolling mills from 18 Ga. (1.2 mm) low carbon steel strips plain steel (ASTM A1008 33,000 PSI min. yield) and pre-galvanized steel strips, (ASTM A653 33,000 PSI min. yield). A continuous slot with inturred lips provides the ability to make attachments at any point. Channel combinations are made with new state of the art, high-tech welding equipment.

Lengths

Standard lengths are 10' (3.05 m) and 20' (6.09 m) for B62 series, and 10' (3.05 m) for B72 series. Custom lengths are available.

Fittings

Mini fittings are formed from hot rolled pickled and oiled strip or sheet steel (ASTM A1011, HSLAS, Grade 50, Class1). The following dimensions apply to all fittings except as noted on the drawings:

Hole Size— $9/32$ " (7.14 mm) Dia.

Hole Spacing— $13/32$ " (10.3 mm) from end and $11/16$ " (27.0 mm) on center.

Width— $13/16$ " (20.6 mm)

Thickness— $1/8$ " (3.2 mm)

Materials & Finishes*

Finish Code	Finish	Specification
PLN	Plain	ASTM A1011, HSLAS, Grade 50, Class 1
ZN	Electro-Plated Zinc	ASTM B633 SC3 Type II
GRN	DURA-GREEN™	
GLV	Pre-Galvanized	ASTM A653 33,000 PSI min. yield
HDG	Hot-Dipped Galvanized	ASTM A123

*Unless otherwise noted.

Metric

Metric dimensions are shown in parentheses. Unless noted, all metric dimensions are in millimeters.

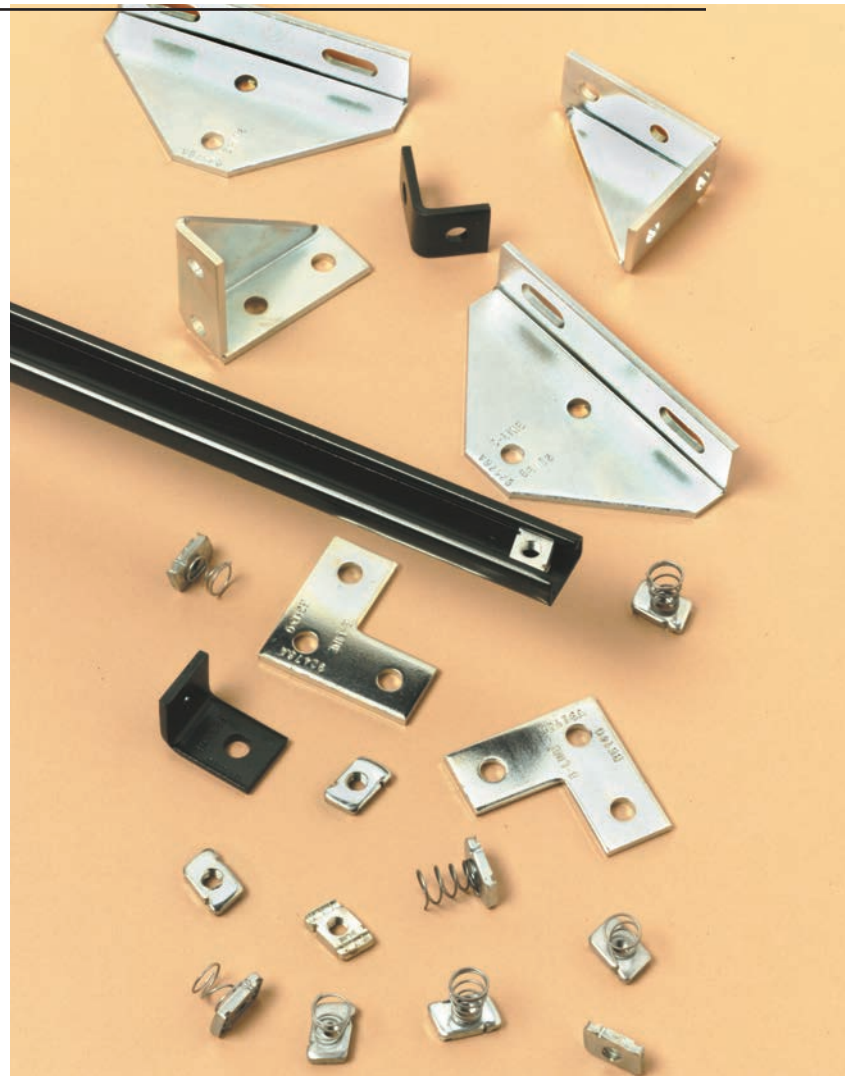

B72 Channel

- Thickness: 18 Ga. (1.2 mm)
- Standard lengths: 10' (3.05 m)
- Standard finishes: Plain, DURA-GREEN™, Pre-Galvanized
- Weight: .29 Lbs./Ft. (.43 kg/m)

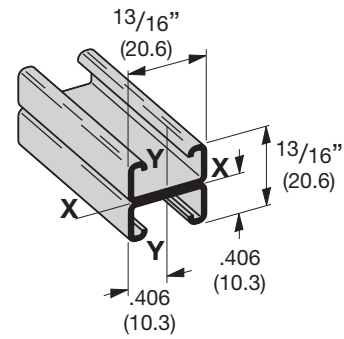
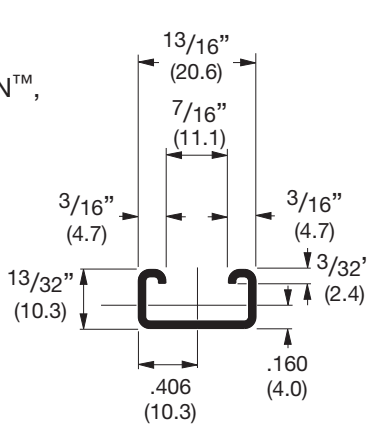
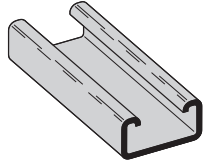

B72A
Wt. .58 Lbs./Ft. (.87 kg/m)

SECTION PROPERTIES

Channel	Weight lbs./ft. kg/m	Areas of Section		Moment of Inertia (I)		Section Modulus (S)		Radius of Gyration (r)		Moment of Inertia (I)		Section Modulus (S)		Radius of Gyration (r)	
		sq. in.	cm ²	in. ⁴	cm ⁴	in. ³	cm ³	in.	cm	in. ⁴	cm ⁴	in. ³	cm ³	in.	cm
B72	.287 (.43)	.084 (.54)	.0018 (.07)	.0073 (.12)	.146 (.37)	.0077 (.32)	.0190 (.31)	.302 (.77)							
B72A	.574 (.85)	.169 (1.09)	.0078 (.32)	.0192 (.31)	.215 (.55)	.0155 (.65)	.0382 (.63)	.303 (.77)							

Calculations of section properties are based on metal thicknesses as determined by the AISI Cold-Formed Steel Design Manual.

BEAM LOADING

Beam Span In. mm	Channel Style	Uniform Load and Deflection				Uniform Load @ Deflection =			
		Lbs.	kN	In.	mm	1/240 Span	1/360 Span	Lbs.	kN
12 (305)	B72	116	(0.51)	.051	(1.29)	113	(0.50)	75	(0.32)
	B72A	210*	(0.93)	.020	(.51)	210*	(0.93)	210*	(0.93)
24 (609)	B72	58	(0.26)	.206	(5.23)	28	(0.12)	19	(0.08)
	B72A	159	(0.71)	.125	(3.17)	127	(0.56)	85	(0.38)
36 (914)	B72	39	(0.17)	.465	(11.81)	13	(0.06)	8	(0.03)
	B72A	106	(0.45)	.281	(7.14)	57	(0.25)	38	(0.17)
36 (1219)	B72	29	(0.13)	.827	(21.00)	7	(0.03)	5	(0.02)
	B72A	80	(0.35)	.500	(12.70)	32	(0.14)	21	(0.09)
60 (1524)	B72	23	(0.10)	1.292	(32.81)	5	(0.02)	3	(0.01)
	B72A	64	(0.28)	.782	(19.86)	20	(0.09)	14	(0.06)

Based on simple beam condition using an allowable design stress of 25,000 psi (172 MPa) in accordance with MFMA, with adequate lateral bracing (see page 11 for further explanation). Actual yield point of cold rolled steel is 42,000 psi. To determine concentrated load capacity at mid span, multiply uniform load by 0.5 and corresponding deflection by 0.8. *Failure determined by weld shear.

COLUMN LOADING

Unbraced Height In. mm	Channel Style	Max. Column Loading K = .80				Max. Column Loading (Loaded @ C.G.)					
		Loaded @ C.G.		Loaded @ Slot Face		K = .65		K = 1.0		K = 1.2	
		Lbs.	kN	Lbs.	kN	Lbs.	kN	Lbs.	kN	Lbs.	kN
12 (305)	B72	1598	(7.11)	539	(2.40)	1712	(7.61)	1410	(6.27)	1181	(5.25)
	B72A	3600	(16.01)	986	(4.38)	3700	(16.46)	3433	(15.27)	3229	(14.36)
24 (609)	B72	701	(3.12)	320	(1.42)	1050	(4.67)	450	(2.00)	313**	(1.39)
	B72A	2710	(12.05)	802	(3.57)	3113	(13.85)	2043	(9.09)	1421	(6.32)
36 (914)	B72	313**	(1.39)	188	(0.83)	473	(2.10)	201**	(0.89)	-	-
	B72A	1421	(6.32)	569	(2.53)	2135	(9.50)	909	(4.04)	631**	(2.81)
36 (1219)	B72	177**	(0.79)	122	(0.54)	267**	(1.19)	-	-	-	-
	B72A	799	(3.55)	404	(1.80)	1211	(5.39)	512**	(2.28)	355**	(1.58)
60 (1524)	B72	113**	(0.50)	85	(0.38)	171**	(0.76)	-	-	-	-
	B72A	512**	(2.28)	298	(1.32)	775	(3.45)	327**	(1.45)	-	-

**Where the slenderness ratio $\frac{KL}{r}$ exceeds 200, and K = end fixity factor, L = actual length and r = radius of gyration.

Reference page 200 for general fitting specifications.

Reference Data

General Notes for Strut-Type Channel Raceway

UL Category RIUU - B-Line, Inc., Highland, IL 62249 December 11, 1998 (C)
 FLUORESCENT AND INCANDESCENT LIGHTING



Suitable for not more than the number of wires of the sizes and types indicated in the following tables. Intended to enclose circuits operating at potentials not exceeding 600 volts between conductors. In all cases, the B217-20 or B217P snap-in cover is required to complete raceway closure. When using B217-24 snap-in cover, the number of wires is limited to 7 or fewer conductors no larger than #12 AWG.

B-Line's strut-type channel raceways and fittings are manufactured and tested to comply with the UL Standard for Safety for Strut-Type Channel Raceways and Fittings (UL 5B) in accordance with Article 384 of the 2002 National Electrical Code, NFPA 70.

1. Support spans for strut-type channel raceway shall not exceed 10 foot intervals.
2. No conductor larger than that for which the raceway is listed shall be installed in strut-type channel raceways. No wires under 14AWG or over 6AWG are allowed in any of B-Line's strut-type channel raceway. See tables 1, 2 and 3 below for a listing of the approved conductors for B-Line's strut-type channel raceways.
3. The number of conductors permitted in strut-type channel raceway shall not exceed the percentage fill using Table 384-22 and the applicable outside diameter of specific types and sizes of wire given in the tables in chapter 9 of the National Electrical Code. Table 384-22 lists two different percent fill areas depending on the use of internal or external joiners. Use 40% area fill with external joiners and 25% area fill for internal joiners.
4. Items in the electrical section of the B-Line Strut Systems Catalog identified by the UL symbol provide for electrical continuity. Other items require the use of a separate grounding wire.
5. If strut-type channel raceway is connected to another wiring system, the raceway must be field-tapped adjacent to the wire entry point to accept a #10-32 or larger grounding screw. A plated or stainless steel screw may be used. A sheet metal screw is not acceptable. Drill and tap the grounding wire hole before installing wires in raceway or move installed wires out of the way to avoid damage. After drilling and tapping, remove metal chips and burrs before installing screw.

TABLE 1: MAXIMUM NUMBER OF WIRES (Adjusted per NEC Table 384.22 for 40% fill)

Use this table to determine the type and number of conductors for use with B-Line's strut-type channel raceway using external joiners. This table applies for all installations except for the support and supply of electric discharge type lighting fixtures. See table 2 and 3 for further information.

Insulation Type	Wire Size AWG.	B11 B11K06	B12 B12K06	B22 B22K06	B24 B24K06	B26 B26K06	B32 B32K06	B56 B56K06
FEP, FEPB	14	172	127	81	81	81	67	36
	12	126	92	59	59	59	49	26
	10	90	66	42	42	42	35	19
	8	51	38	24	24	24	20	11
	6	24	17	11	12	12	9	5
RH, RHH, RHW	14	52	38	24	26	27	20	12
	12	45	33	21	22	23	17	10
	10	37	27	17	18	19	14	8
	8	20	14	9	10	10	7	4
	6	14	10	6	7	7	5	3
T, TW	14	124	91	58	58	58	48	26
	12	95	70	45	45	45	37	20
	10	69	51	33	33	33	27	14
	8	36	26	17	18	19	14	8
	6	21	15	9	10	11	8	5
THHN, THWN	14	178	131	84	84	84	69	37
	12	130	95	61	61	61	50	27
	10	82	60	38	38	38	32	17
	8	46	34	21	22	22	17	10
	6	33	24	15	16	16	12	7
THW	14	82	61	39	39	39	32	17
	12	66	49	31	31	31	26	14
	10	52	38	24	24	24	20	11
	8	29	21	13	14	15	11	6
	6	21	15	10	10	11	8	5
XHHW	14	124	91	58	58	58	48	26
	12	95	70	45	45	45	37	20
	10	71	52	33	33	33	28	15
	8	37	27	17	19	19	14	8
	6	27	20	13	14	14	10	6