

# Pipe/conduit clamps & hangers



Our beam attachments and pipe supports offered in this section are designed to provide supports without drilling or welding. A complete selection of beam clamps, pipe clamps, rollers, supports and accessories are designed for use with our channels and offer many installation advantages.

## Materials & Finishes\*

Pipe clamps, pipe hangers, beam clamps, brackets, and rollers are made from low carbon steel strips, plates or rod unless noted.

\*Unless otherwise noted.

## Load Data

The load data published includes a safety factor of 5.0 unless noted (safety factor = ratio of ultimate load to the design load).

## Recommended Bolt Torque (unless noted)

\*See chart on page 154 for recommended setscrew torquing.

Finish Code	Finish	Specification
PLN	Plain	ASTM A1011 33,000 PSI min. yield
ZN	Electro-Plated Zinc	ASTM B633 SC3 Type III or ASTM A653
GRN	DURA GREEN™	
DCU	DURA-COPPER™	
HDG	Hot-Dipped Galvanized	ASTM A123
YZN	Yellow Zinc Chromate	ASTM B633 SC3 Type II
SS4	Stainless Steel Type 304	ASTM A240
SS6	Stainless Steel Type 316	ASTM A240
AL	Aluminum	ASTM B209

Bolt Size	1/4"-20	5/16"-18	3/8"-16	1/2"-13
Foot/Lbs.	6	11	19	50
Nm	8	15	26	68

## Metric

Metric dimensions are shown in parentheses. Unless noted, all metric dimensions are in millimeters.

## B2207 thru B2213 Multi-Grip Pipe Clamps for Thinwall (EMT), I.M.C., Rigid Conduit or Pipe

- Safety Factor of 5
- Add PA to suffix for pre-assembled pipe clamps
- Includes combination recess hex head machine screw and square nut
- Material: ASTM A1011 33,000 PSI min. yield
- Standard finish: ZN



For UL installations, follow Table 9 in UL2239.

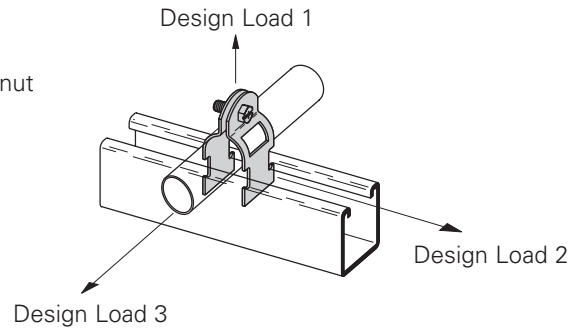

Part No.	Nominal Size In. mm	Material Thickness In. mm	O.D. Size Range		Alternate For Clamp No.'s	Design Load 1		Design Load 2		Design Load 3		Wt./C Lbs. kg
			In.	mm		Lbs.	kN	Lbs.	kN	Lbs.	kN	
B2207	3/8" (10)	16 Ga. (1.5)	.557-	.706 (14.2-17.9)	B2000, B2001, B2026	400	(1.78)	50	(.22)	50	(.22)	9 (4.1)
B2208	1/2" (15)	16 Ga. (1.5)	.701-	.875 (17.8-22.2)	B2001, B2008, B2027, B2028	400	(1.78)	50	(.22)	50	(.22)	11 (5.0)
B2209	3/4" (20)	14 Ga. (1.9)	.917-	1.081 (23.2-27.4)	B2002, B2009,	400	(1.78)	50	(.22)	50	(.22)	12 (5.4)
B2210	1" (25)	14 Ga. (1.9)	1.125-	1.375 (28.6-34.9)	B2003, B2010, B2030, B2031,	400	(1.78)	50	(.22)	50	(.22)	13 (5.9)
B2211	1 1/4" (32)	14 Ga. (1.9)	1.500-	1.691 (38.1-42.9)	B2004, B2011, B2033, B2034	400	(1.78)	50	(.22)	50	(.22)	15 (6.8)
B2212	1 1/2" (40)	12 Ga. (2.6)	1.735-	1.931 (44.0-49.0)	B2005, B2012, B2035	600	(2.67)	75	(.33)	75	(.33)	23 (10.4)
B2213	2" (50)	12 Ga. (2.6)	2.192-	2.400 (55.7-60.9)	B2006, B2013 B2039	600	(2.67)	75	(.33)	75	(.33)	26 (11.8)

Pipe/Conduit Clamps & Hangers

## BPC-8 thru BPC-64 Break-Apart Conduit Clamp

- Design Load 200 Lbs. (.896 kN)
- Includes combination recess hex head machine screw
- Material: ASTM A1011 33,000 PSI min. yield
- Recommended Torque 30 in. - lbs.
- Standard finish: ZN



For UL installations, follow Table 9 in UL2239.

Part No.	Rigid or EMT Conduit Size		Wt./C	
	In.	mm	Lbs.	kg
BPC-8	1/2"	(21.3)	11.2	(5.1)
BPC-12	3/4"	(26.7)	12.7	(5.8)
BPC-16	1"	(33.4)	14.5	(6.6)
BPC-20	1 1/4"	(42.2)	16.5	(7.5)
BPC-24	1 1/2"	(48.3)	18.5	(8.4)
BPC-32	2"	(60.3)	21.5	(9.8)
BPC-40	2 1/2"	(73.0)	21.5	(9.8)
BPC-48	3"	(88.9)	22.0	(10.0)
BPC-56	3 1/2"	(101.6)	23.0	(10.4)
BPC-64	4"	(114.3)	27.5	(12.5)

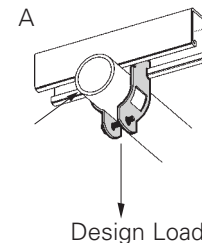

Recommended torque: 35 in-lbs

Reference page 168 for general fitting and standard finish specifications.

# Pipe clamps

## B2000 Series Pipe and Conduit Clamps

- Safety Factor of 5
- Add PA to suffix for pre-assembled pipe clamps
- Includes combination recess hex head machine screw and square nut
- Material: 16 Ga. (1.5), 14 Ga. (1.9), 12 Ga. (2.6) ASTM A653 33,000 PSI min. yield and 11 Ga. (3.0) ASTM A1011HSLA Gr. 50
- Standard finishes: ZN, HDG, SS4, SS6, AL

Note: For EMT sizes 2 1/2" and larger use rigid conduit sizes.

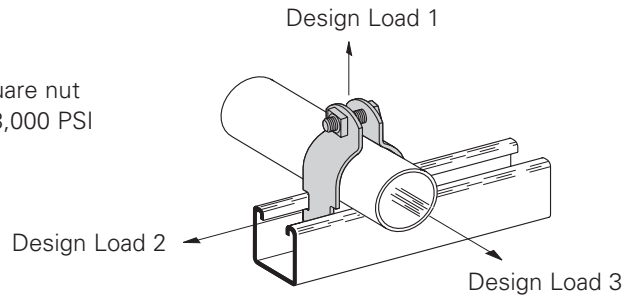

## Thinwall Conduit (EMT) Clamps

Part No.	Conduit Size In. mm	Material Thickness In. mm	Design Load 1		Design Load 2		Design Load 3		Wt./C	
			Lbs.	kN	Lbs.	kN	Lbs.	kN	Lbs.	kg
B2000	3/8" (10)	16 Ga. (1.5)	400 u	(1.78)	50	(.22)	50	(.22)	10	(4.5)
B2001	1/2" (15)	16 Ga. (1.5)	400 u	(1.78)	50	(.22)	50	(.22)	10	(4.5)
B2002	3/4" (20)	16 Ga. (1.9)	400 u	(1.78)	50	(.22)	50	(.22)	11	(5.0)
B2003	1" (25)	14 Ga. (1.9)	600 u	(2.67)	75	(.33)	75	(.33)	16	(7.2)
B2004	1 1/4" (32)	14 Ga. (1.9)	600 u	(2.67)	75	(.33)	75	(.33)	19	(8.6)
B2005	1 1/2" (40)	12 Ga. (2.6)	800 u	(3.56)	125	(.56)	125	(.56)	28	(12.7)
B2006	2" (50)	12 Ga. (2.6)	800 u	(3.56)	125	(.56)	125	(.56)	33	(14.9)

## Rigid or Conduit or Pipe Clamps

Part No.	Conduit Size In. mm	Material Thickness In. mm	Design Load 1		Design Load 2		Design Load 3		Wt./C	
			Lbs.	kN	Lbs.	kN	Lbs.	kN	Lbs.	kg
B2001	3/8" (10)	16 Ga. (1.5)	400 u	(1.78)	50	(.22)	50	(.22)	10	(4.5)
B2008	1/2" (15)	16 Ga. (1.5)	400 u	(1.78)	50	(.22)	50	(.22)	11	(5.0)
B2009	3/4" (20)	14 Ga. (1.9)	600 u	(2.67)	75	(.33)	75	(.33)	15	(6.8)
B2010	1" (25)	14 Ga. (1.9)	600 u	(2.67)	75	(.33)	75	(.33)	16	(7.2)
B2011	1 1/4" (32)	14 Ga. (1.9)	600 u	(2.67)	75	(.33)	75	(.33)	20	(9.1)
B2012	1 1/2" (40)	12 Ga. (2.6)	800 u	(3.56)	125	(.56)	125	(.56)	30	(13.6)
B2013	2" (50)	12 Ga. (2.6)	800 u	(3.56)	125	(.56)	125	(.56)	34	(15.4)
B2014	2 1/2" (65)	12 Ga. (2.6)	800 u	(3.56)	125	(.56)	125	(.56)	38	(17.2)
B2015	3" (80)	12 Ga. (2.6)	800 u	(3.56)	125	(.56)	125	(.56)	44	(19.9)
B2016	3 1/2" (90)	12 Ga. (2.6)	800 u	(3.56)	125	(.56)	125	(.56)	49	(22.2)
B2017	4" (100)	12 Ga. (2.6)	800 u	(3.56)	125	(.56)	125	(.56)	54	(24.5)
B2018	4 1/2" (115)	11 Ga. (3.0)	1000 u	(4.45)	200	(.89)	150	(.67)	70	(31.7)
B2019	5" (125)	11 Ga. (3.0)	1000 u	(4.45)	200	(.89)	150	(.67)	77	(34.9)
B2020	6" (150)	11 Ga. (3.0)	1000 u	(4.45)	200	(.89)	150	(.67)	100	(45.3)
B2021	7" (175)	11 Ga. (3.0)	1000	(4.45)	250	(1.11)	200	(.89)	115	(52.1)
B2022	8" (200)	11 Ga. (3.0)	1000	(4.45)	250	(1.11)	200	(.89)	128	(58.0)
B2130	10" (254)	11 Ga. (3.0)	1000	(4.45)	250	(1.11)	200	(.89)	160	(72.6)
B2132	12" (305)	11 Ga. (3.0)	1000	(4.45)	250	(1.11)	200	(.89)	185	(83.9)



As shown with u For UL installations, follow Table 9 in UL2239.

Reference page 168 for general fitting and standard finish specifications.

## B2000 Series PVC Clamps

- Safety Factor of 5
- Add PA to suffix for pre-assembled pipe clamps
- Includes combination recess hex head machine screw and square nut
- Material: 16 Ga. (1.5), 14 Ga. (1.9), 12 Ga. (2.6) ASTM A653 33,000 PSI min. yield and 11 Ga. (3.0) ASTM A1011HSLA Gr. 50
- Standard finishes: PVC

### Clamp Sizing Chart for PVC Coated Rigid Conduit and Clamps

Nominal Conduit Size In. mm	Conduit Coating			
	.020 (.51mm)		.040 (1.01mm)	
	Clamp Coating		Clamp Coating	
	0	.020" (.51mm)	0	.020" (.51mm)
1/2" (15)	B2008	B2002	B2002	B2009
3/4" (20)	B2030	B2030	B2030	B2003
1" (25)	B2032	B2010	B2010	B2004
1 1/4" (32)	B2005	B2005	B2005	B2005
1 1/2" (40)	B2012	B2037	B2037	B2037
2" (50)	B2013	B2041	B2041	B2041
2 1/2" (65)	B2014	B2045	B2045	B2045
3" (80)	B2015	B2050	B2050	B2050
3 1/2" (90)	B2016	B2054	B2054	B2054
4" (100)	B2017	B2058	B2058	B2058
5" (125)	B2019	B2066	B2066	B2066
6" (150)	B2020	B2115	B2115	B2115

\*See B2000 O.D. pipe and conduit clamp chart on pgs. 131-132 for corresponding clamp load data.

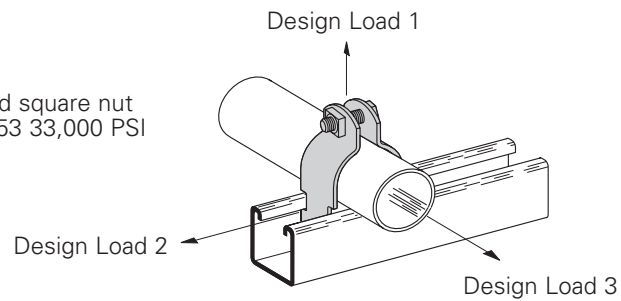

### Clamp Sizing Chart for PVC Coated Thinwall (EMT) Conduit and Clamps

Nominal Conduit Size In. mm	Conduit Coating			
	.020 (.51mm)		.040 (1.01mm)	
	Clamp Coating		Clamp Coating	
	0	.020" (.51mm)	0	.020" (.51mm)
3/8" (10)	B2026	B2026	B2026	B2001
1/2" (15)	B2027	B2027	B2027	B2008
3/4" (20)	B2009	B2009	B2009	B2009
1" (25)	B2003	B2031	B2031	B2031
1 1/4" (32)	B2004	B2011	B2011	B2011
1 1/2" (40)	B2005	B2005	B2005	B2012
2" (50)	B2039	B2039	B2039	B2013

\*See B2000 O.D. pipe and conduit clamp chart on pgs. 131-132 for corresponding clamp load data.

## B2000 Series Copper Tubing Clamps

- Safety Factor of 5
- Add PA to suffix for pre-assembled pipe clamps
- Includes combination recess hex head machine screw and square nut
- Material: 16 Ga. (1.5), 14 Ga. (1.9), 12 Ga. (2.6) ASTM A1011 33,000 PSI min. yield and 11 Ga. (3.0) ASTM A1011HSLA Gr. 50
- Standard finish: Exclusive DURA-COPPER™ Finish (DCU)

### Copper Tubing Clamps

Part No.	Tubing Size In. (mm)	O.D. Size In. (mm)	Material Thickness In. (mm)	Design Load 1		Design Load 2		Design Load 3		Wt./C Lbs. kg
				Lbs.	kN	Lbs.	kN	Lbs.	kN	
B2024DCU	1/4" (6.3)	.375 (9.5)	16 Ga. (1.5)	400 (1.78)	50 (.22)	50 (.22)	50 (.22)	8 (3.6)		
B2025DCU	3/8" (9.5)	.500 (12.7)	16 Ga. (1.5)	400 (1.78)	50 (.22)	50 (.22)	50 (.22)	9 (4.1)		
B2026DCU	1/2" (12.7)	.625 (15.9)	16 Ga. (1.5)	400 (1.78)	50 (.22)	50 (.22)	50 (.22)	10 (4.5)		
B2027DCU	5/8" (15.9)	.750 (19.0)	16 Ga. (1.5)	400 (1.78)	50 (.22)	50 (.22)	50 (.22)	10 (4.5)		
B2008DCU	3/4" (19.0)	.875 (22.2)	16 Ga. (1.5)	400 (1.78)	50 (.22)	50 (.22)	50 (.22)	11 (5.0)		
B2030DCU	1" (25.4)	1.125 (28.6)	14 Ga. (1.9)	600 (2.67)	75 (.33)	75 (.33)	75 (.33)	15 (6.8)		
B2010DCU	1 1/4" (31.7)	1.375 (34.9)	14 Ga. (1.9)	600 (2.67)	75 (.33)	75 (.33)	75 (.33)	17 (7.7)		
B2011DCU	1 1/2" (38.1)	1.625 (41.3)	14 Ga. (1.9)	600 (2.67)	75 (.33)	75 (.33)	75 (.33)	19 (8.6)		
B2038DCU	2" (50.8)	2.125 (54.0)	12 Ga. (2.6)	800 (3.56)	125 (.56)	125 (.56)	125 (.56)	32 (14.5)		
B2042DCU	2 1/2" (63.5)	2.625 (66.7)	12 Ga. (2.6)	800 (3.56)	125 (.56)	125 (.56)	125 (.56)	35 (15.9)		
B2046DCU	3" (76.2)	3.125 (79.4)	12 Ga. (2.6)	800 (3.56)	125 (.56)	125 (.56)	125 (.56)	39 (17.7)		
B2050DCU	3 1/2" (88.9)	3.625 (92.1)	11 Ga. (3.0)	1000 (4.45)	200 (.89)	150 (.67)	150 (.67)	54 (24.5)		
B2054DCU	4" (101.6)	4.125 (104.8)	11 Ga. (3.0)	1000 (4.45)	200 (.89)	150 (.67)	150 (.67)	61 (27.6)		
B2062DCU	5" (127.0)	5.125 (130.2)	11 Ga. (3.0)	1000 (4.45)	200 (.89)	150 (.67)	150 (.67)	70 (31.7)		
B2110DCU	6" (152.5)	6.125 (155.6)	11 Ga. (3.0)	1000 (4.45)	250 (1.11)	200 (.89)	200 (.89)	94 (42.6)		
B2126DCU	8" (203.2)	8.125 (206.4)	11 Ga. (3.0)	1000 (4.45)	250 (1.11)	200 (.89)	200 (.89)	123 (55.8)		

Reference page 168 for general fitting and standard finish specifications.