

Atlas LED Edge Lit Panel

ELP22LED 30 Watt LED Edge Lit Panel



Project Information	
Job Name	
Fixture Type	30 Watt LED Edge Lit Panel
Catalog Number	ELP2230LED50U
Approved by	

SPECIFICATIONS:

	5000K
Lumens:	3,100
Watts:	30
Lumens/Watt:	103
CRI:	80
CCT:	5000
Lifespan:	50,000+ hrs. ¹

Construction:
Designed for commercial and industrial applications, providing cooler operating temperatures, brighter light and longer LED life. Housing features metal back panel and wiring compartment. Frame is constructed of Aluminum that is post-painted white.

Optics:
Frosted white lens diffuses light. Atlas Edge Lit Panels utilize edge-lit technology and provide full diffusion with excellent uniformity. Available in 5000K color temperatures. Color rendering index > 80
120° beam angle

Electrical:
Universal 120-277 AC voltage (50-60Hz) is standard
0-10 V Dimming capability is standard
Total harmonic distortion < 20%
Power factor: < 90%
Suitable for ambient temperatures from -25° to 45°C (-13°F to 113°F)

LEDs:
Long-life LEDs provide 50,000 hours of operation with at least 70% of initial output (L70).

Installation:
Easy installation in new construction or retrofit. For surface-mount and suspension-mount applications, accessories are to be ordered separately. See Accessories section.

Listings:
Luminaire is certified to ETL Standards for Damp Locations
DesignLights Consortium qualified luminaire, eligible for rebates from DLC member utilities.

Testing:
Atlas LED luminaires have been tested by an independent laboratory in accordance with IESNA LM-79 & LM-80.

Warranty:
Five-year limited warranty

Emergency Backup:
For factory installed Emergency Back-Up add suffix EB to part number. Provides emergency illumination (1,100 lumens) for a minimum of 90 minutes.

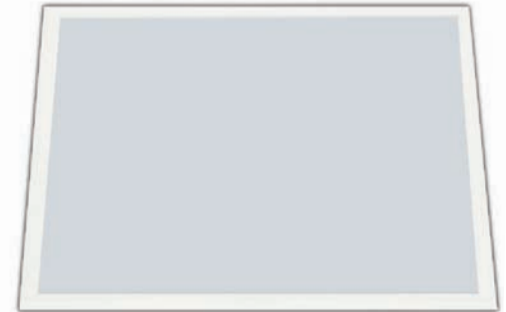

DIMENSIONS:
Weight: 16.53 lbs.
Width: 23.75"
Depth: 23.75"
Inner Depth: 21.4375"

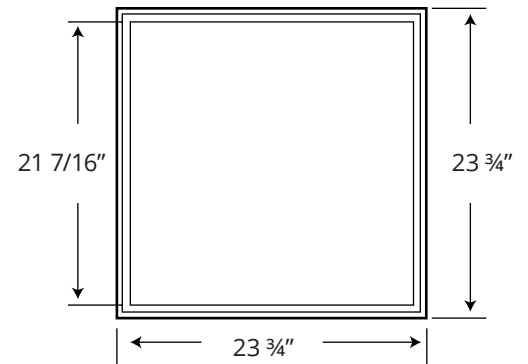

¹LED Life Span Based Upon LM-80 Test Results

Rebates and Incentives are available in many areas. Contact an Atlas Representative for more information.



Edge Lit Panel

ELP22LED 30 Watt LED Edge Lit Panel

PHOTOMETRICS:

Zonal Lumen Distribution

0-10	96.79
10-20	276.22
20-30	421.13
30-40	508.61
40-50	531.98
50-60	483.96
60-70	374.97
70-80	230.28
80-90	75.38
Total	2999.32

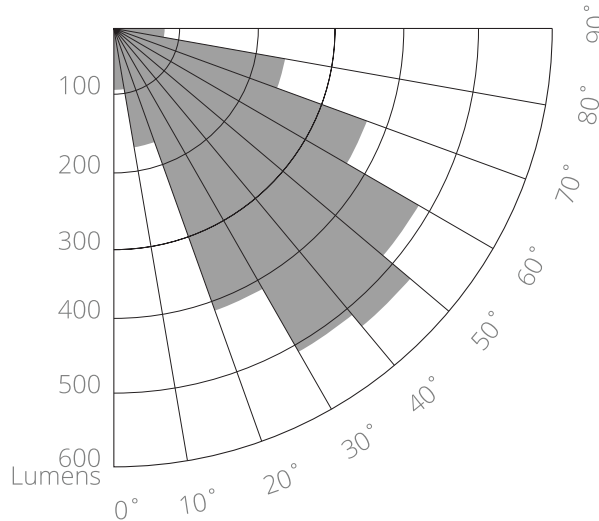

ACCESSORIES:

Product	Part Number	Description
Frame Kits for Surface Mount Panels	SMK22	For 23.74" x 23.74" panel surface mounted. Dimension: 124.02" x 24.02" x 2.17" White color finished

ORDERING INFORMATION:

PRODUCT SERIES	WATTAGE	COLOR TEMP	DRIVER	OPTIONS
ELP22 ELP22 = Edge Lit Panel	30LED 30LED = 30 System Watts	50 50 = 5000K	U U = Universal Voltage (120-277V) with 0-10v Dimming	EB = Emergency Back-Up

ATLAS LIGHTING PRODUCTS, INC.

PO BOX 2348 | Burlington, NC 27216
800-849-8485 | fax: 336-227-0110 | www.atlasled.com