

Threaded Conduit Hubs

For RMC and IMC

NEC/CEC — Suitable for hazardous locations:
 Class I, Division 2; Class III, Divisions 1 and
 2 per NEC 501-4(B), 501.10(B)(4), 502-4(A)(2),
 503-3(A)

Applications

- Insulated throat form with bonding screw.
- Provides a more vibration resistant connection with assured ground continuity

Features

- Female bushed nipple type
- Female thread for rigid conduit and IMC
- Takes less space
- Recessed O-ring seal outside the box provides a watertight threaded hub on enclosures.
- Suitable for use with service entrance conduit.

Material/Finish

- Ductile iron/zinc electroplate
- Gasket: neoprene

NEC/CEC Certifications and Compliances

- UL Standard: ANSI/UL 514B
- UL Listed: E-11853
- CSA Standard: C22.2 No. 18
- CSA Certified: 009795
- UL Listed as suitable for use in wet locations.
- NEMA: FB-1, -4, and -12.

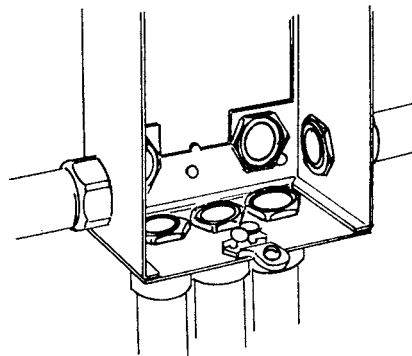

HUB-125

APPLETON™

COMMERCIAL AND INDUSTRIAL FITTINGS: RIGID AND IMC CONDUIT FITTINGS

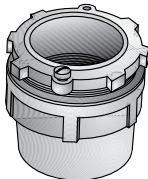
	Trade Size (Inches)	Hole Diameter in Millimeters (Inches)		Panel Thickness in Millimeters (Inches)		Dimensions in Millimeters (Inches)		Weight per 100 kg (lb)	Appleton™ Catalog Number
		Max.	Min.	Max.	Min.	A	B		
Straight									
	1/2	22.4	23.9	1.5	2.0	27.4	28.2	7.26	HUB-50
		(0.88)	(0.94)	(0.06)	(0.08)				
	3/4	24.6	29.5	2.3	2.0	28.2	35.1	10.43	HUB-75
		(0.97)	(1.16)	(0.09)	(0.08)				
	1	27.7	31.0	2.3	6.4	31.8	43.7	17.69	HUB-100
		(1.09)	(1.22)	(0.09)	(0.25)				
		35.8	1.5	2.0					
		34.0	(1.41)	(0.06)	(0.08)	(1.25)	(1.72)	(39.00)	
		37.3	(1.47)	(0.09)	(0.25)				

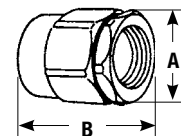

Threaded Conduit Hubs

For RMC and IMC

NEC/CEC — Suitable for hazardous locations:
 Class I, Division 2; Class III, Divisions 1 and
 2 per NEC 501-4(B), 501.10(B)(4), 502-4(A)(2),
 503-3(A)

Trade Size (Inches)	Hole Diameter in Millimeters (Inches)		Panel Thickness in Millimeters (Inches)		Dimensions in Millimeters (Inches)		Weight per 100 kg (lb)	Appleton™ Catalog Number
	Max.	Min.	Max.	Min.	A	B		
Straight — With Bonding Screw								
1-1/4	42.9 (1.69)	45.2 (1.78)	1.5 (0.06)	2.0 (0.08)	45.7 (1.80)	58.7 (2.31)	34.93 (77.00)	HUB-125
		46.7 (1.84)	2.3 (0.09)	7.9 (0.31)				
1-1/2	49.3 (1.94)	51.6 (2.03)	1.5 (0.06)	2.0 (0.08)	46.5 (1.83)	66.8 (2.63)	41.73 (92.00)	HUB-150
		53.1 (2.09)	2.3 (0.09)	7.9 (0.31)				
2	60.7 (2.39)	64.3 (2.53)	1.5 (0.06)	2.0 (0.08)	47.8 (1.88)	79.5 (3.13)	60.78 (134.00)	HUB-200
		65.8 (2.59)	2.3 (0.09)	7.9 (0.31)				
2-1/2	73.4 (2.89)	76.7 (3.02)	2.3 (0.09)	7.9 (0.31)	60.7 (2.39)	92.2 (3.63)	107.05 (236.00)	HUB-250
3	89.4 (3.52)	92.5 (3.64)	2.3 (0.09)	7.9 (0.31)	62.9 (2.48)	25.4 (1.00)	140.61 (310.00)	HUB-300
3-1/2	102.1 (4.02)	104.9 (4.13)	2.3 (0.09)	7.9 (0.31)	81.0 (3.19)	122.2 (4.81)	181.44 (400.00)	HUB-350
4	114.8 (4.52)	117.6 (4.63)	2.3 (0.09)	7.9 (0.31)	66.8 (2.63)	138.2 (5.44)	215.46 (475.00)	HUB-400
90°								
1/2	22.4 (0.88)	23.9 (0.94)	1.5 (0.06)	2.0 (0.08)	32.5 (1.28)	22.4 (0.88)	16.33 (36.00)	HUB-9050
		24.6 (0.97)	2.3 (0.09)	6.4 (0.25)				
3/4	27.7 (1.09)	29.5 (1.16)	1.5 (0.06)	2.0 (0.08)	36.6 (1.44)	23.9 (0.94)	22.68 (50.00)	HUB-9075
		31.0 (1.22)	2.3 (0.09)	6.4 (0.25)				
1	34.0 (1.34)	35.8 (1.41)	1.5 (0.06)	2.0 (0.08)	41.4 (1.63)	28.7 (1.13)	34.02 (75.00)	HUB-90100
		37.3 (1.47)	2.3 (0.09)	6.4 (0.25)				

