

Supply or Ceiling Shutter

TYPE WC

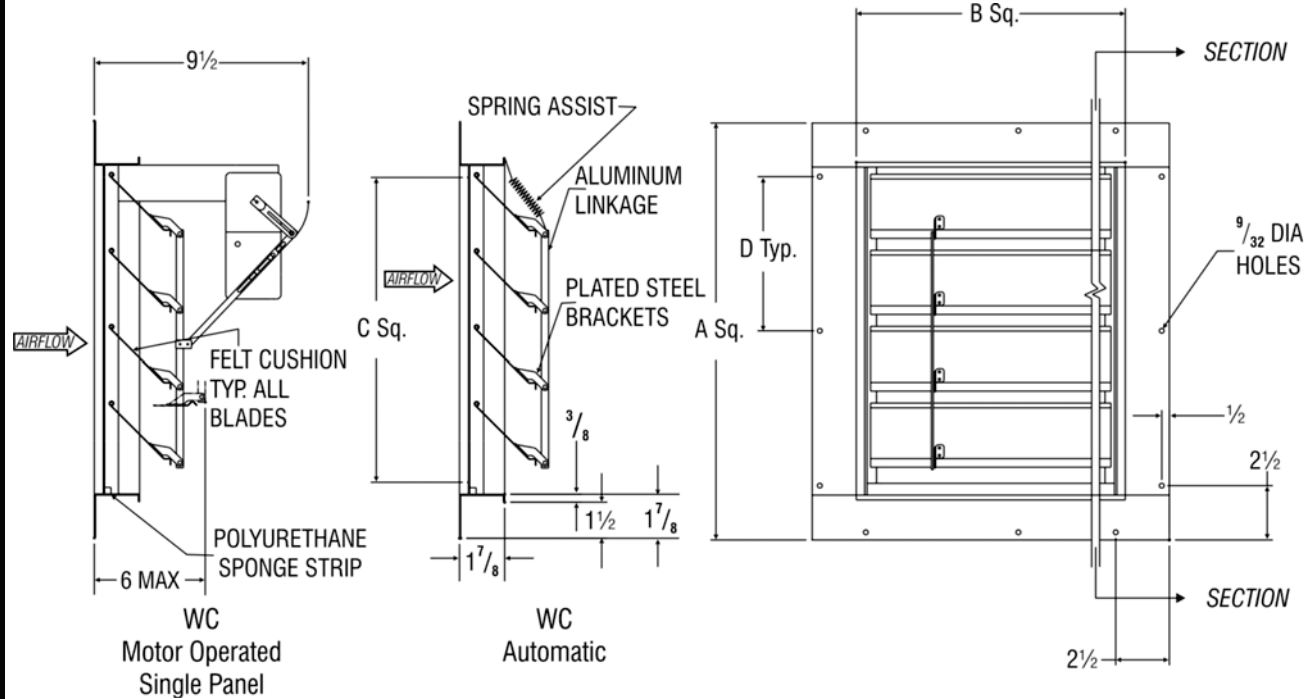

- Maximum differential pressure: 1" W.G.
- Maximum temperature: 200° F without electric motor, 130° F with electric motor
- Dimensions: "B Sq." dimension is nominal frame width and frame height dimension. When dampers are recessed into an opening, the opening must be 3/4" more than "B Sq." dimension.
- 24 Gauge aluminum blades except WC36 & WC60 22 gauge aluminum
- Self lubricating heavy duty nylon bearings
- Felt seals between adjacent blades
- .050 single panel and .063" double panel 6063-T6 extruded aluminum frame
- Maximum velocity 2500 FPM
- Polyurethane sponge seals on ledge and felt between adjacent blades

Model	A	B	C	D	No of Panels	No. of Holes	Motor Kit
WC9	14	11	8	8	1	8	(1) MK-5047
WC10	15	12	10	10	1	8	(1) MK-5047
WC12	17	14	12	12	1	8	(1) MK-5047
WC16	21	18	16	8	1	12	(1) MK-5047
WC18	23	20	18	9	1	12	(1) MK-5047
WC24	29	26	24	12	1	12	(1) MK-5047
WC30	35	32	30	10	1	16	(1) MK-5047
WC36	41	38	36	12	1	16	(1) MK-5047
WC42	47	44	42	10 1/2	2	20	(1) MK-4782
WC48	53	50	48	12	2	20	(2) MK-4782
WC54	59	56	54	9	2	28	(2) MK-5047
WC60	65	62	60	10	3	28	(1) MK-5047 (1) MK-4782

TAG	SHUTTER MODEL	QUANTITY	MOTOR VO:LTAGE	ACTUATOR MODEL NO.	REMARKS

Airmaster® Fan Company

1300 Falahee Road, Jackson, MI 49203

(517)764-2300 Fax: (517)764 -3838 www.airmasterfan.com