

Direct Drive Hazardous Location Exhaust Fan

TYPE HVEX

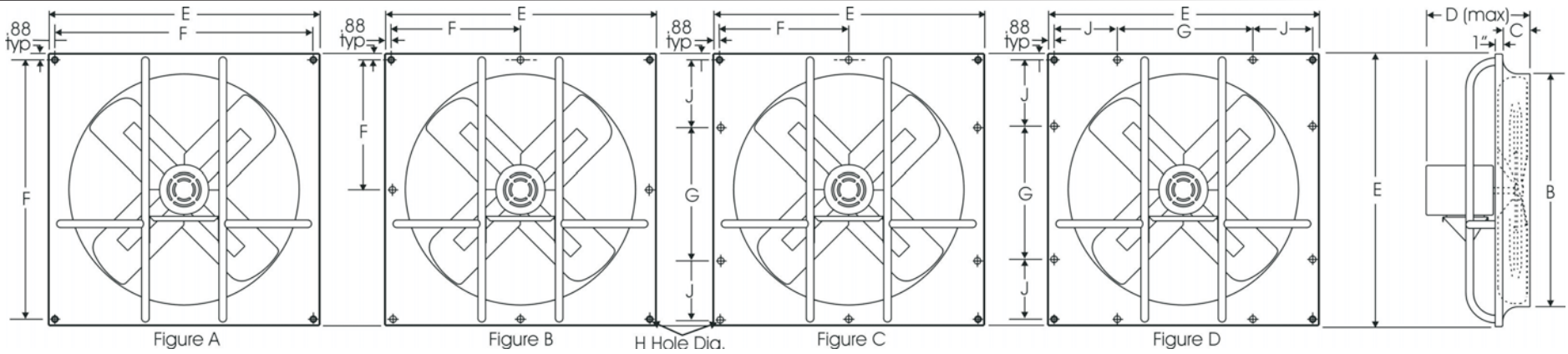

DIMENSIONS

Model	See Figure	Prop. Dia.	B	C	D (1 Phase)	D (3 Phase)	E	F	G	J	H (diameter)	No. Holes
HVEX18	A	18	18.50	1.75	10	10	24	22.25	-	-	.38	4
HVEX24	B	24	24.50	2.50	12	12.25	30	14.12	-	-	.62	8
HVEX30	B	30	30.50	3.00	15	14.25	36	17.12	-	-	.62	8
HVEX36	C	36	36.50	3.25	15	15.75	42	20.12	20.25	10	.62	10
HVWX42	D	42	42.50	3.25	-	20	48	-	20.25	13	.62	12
HVEX48	D	48	48.50	3.25	-	22.50	54	-	20.25	16	.62	12

FEATURES

- Heavy Duty Construction
- Direct Drive
- Formed Venturi
- Non-Overloading Propeller
- Explosion Proof Motors, Class I, Group D, Class II, Groups E, F & G
- Aluminum Bladed Propeller

FAN NO.	QTY.	MODEL NO.	CFM	SP	RPM	HP	VOLT	PHASE	CYCLE	WT.	ACCESSORIES AND REMARKS

Airmaster[®] Fan Company

1300 Falahee Road, Jackson, MI 49203 (517)764-2300 Fax (517) 764-3838

www.airmasterfan.com