

# Air Blaster Low - Medium - High Stands

**TYPE AB**

## AIR BLASTER DIMENSIONS

PROP DIA	A	B	C	D	J	F
18	23	30	25	42	20	32
24	29	30	25	42	26	32
30	35	30	25	42	32	32
36	41	30	25	42	38	32
42	47	30	25½	42	44	32
48	53	30	25½	42	51	32

PROP DIA	G	H	E	K	W
18	23 ½	28	21 ½	18	20
24	29 ½	28	27 ½	24	20
30	35 ½	28	33 ½	30	20
36	41 ½	28	39 ½	36	24
42	47 ½	28	45 ½	42	24
48	53 ½	36	52	48	28

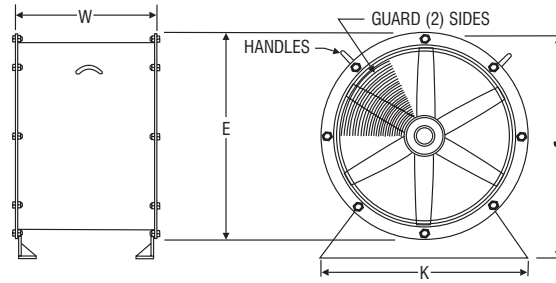

**LOW STAND**

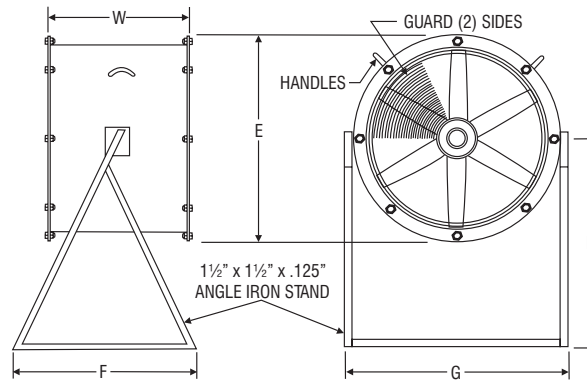

**MEDIUM STAND**

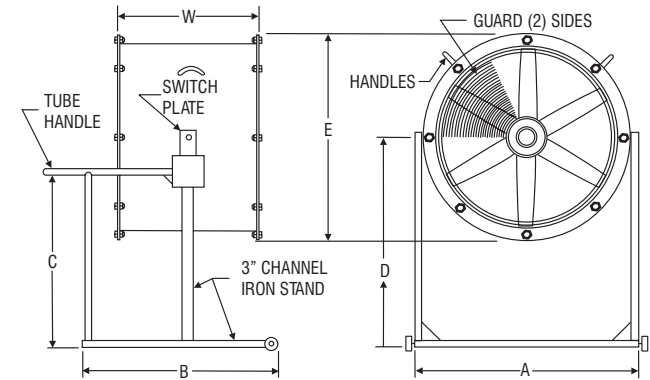

**HIGH STAND**

## FEATURES

- Cast Aluminum Propeller
- Direct Drive
- Welded Steel Construction
- 115/230 V and 230/460 V Totally Enclosed and Explosion Proof, Ball Bearing Motors
- Low, Medium & High Stands Available

FAN NO.	QTY	MODEL #	STAND	CFM	RPM	HP	VOLT	ENCLOSURE	PHASE	CYCLE	WEIGHT	ACCESSORIES & REMARKS

**Airmaster® Fan Company**

1300 Falahee Road, Jackson, MI 49203 (517)764-2300 Fax: (517) 764-3838

www.airmasterfan.com