

# Direct Drive Hazardous Location Exhaust Fan

**TYPE EXG**

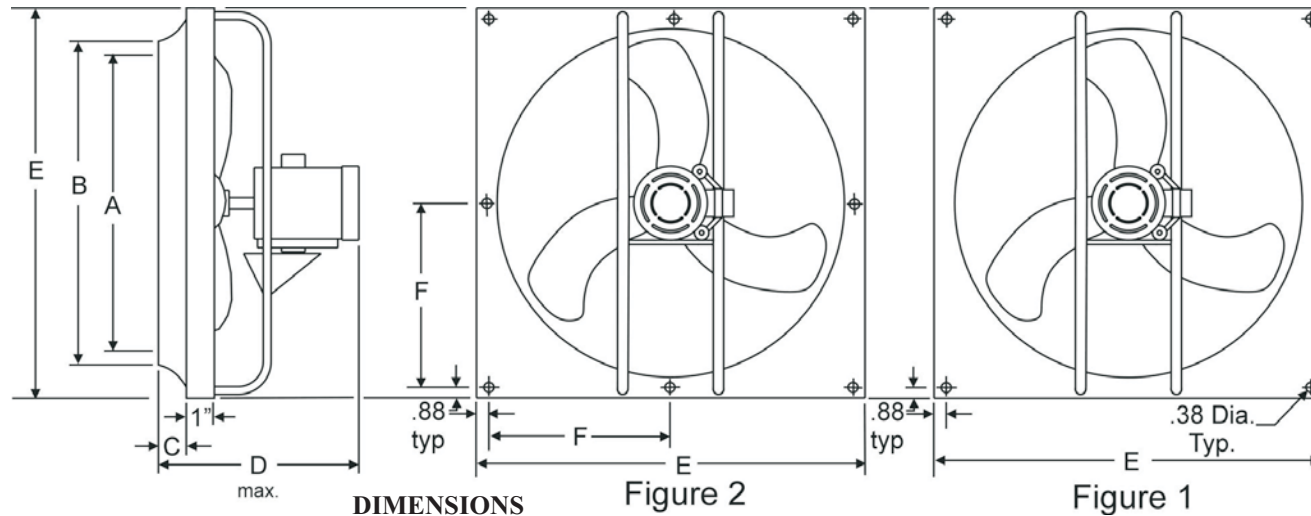

## FEATURES

- Heavy Duty Construction
- Direct Drive
- Formed Venturi
- Non-Overloading Propeller
- Class I, Group D, Class II, Groups F & G Hazardous Location Motors

Model	See Figure	A (Prop. Dia.)	B	C	D	E	F	No. Holes
12EXG	1	12	12.50	1.69	Varies with motor selection	16	-	4
16EXG	1	16	16.50	1.69		22	-	4
18EXG	1	18	18.50	2		24	-	4
24EXG	2	24	24.50	2.50		30	14.12	8

FAN NO.	QTY.	MODEL NO.	CFM	SP	RPM	HP	VOLT	PHASE	CYCLE	WT.	ACCESSORIES AND REMARKS

**Airmaster<sup>®</sup> Fan Company**

1300 Falahee Road, Jackson, MI 49203 (517)764-2300 Fax (517) 764-3838

www.airmasterfan.com