



## Main

|                           |  |
|---------------------------|--|
| Range of Product          | Lexium<br>Altivar  |
| Range Compatibility       | Lexium 05<br>Lexium 28<br>Lexium 32i<br>Lexium 52<br>Altivar 32<br>Lexium 15<br>Altivar Machine ATV320<br>Lexium 32<br>Easy Lexium 16  |
| Product compatibility     | ATV32HU55N4<br>ATV32HU75N4<br>Variable speed drive ATV320 5.5 kW, 380...500 V, three phase<br>Variable speed drive ATV320 7.5 kW, 380...500 V, three phase<br>Variable speed drive ATV320 5.5 kW, 525...600 V, three phase<br>Variable speed drive ATV320 7.5 kW, 525...600 V, three phase<br>Motion servo drive LXM16D 0.75 kW, 200...230 V, single phase<br>Motion servo drive LXM16D 1 kW, 200...230 V, single phase<br>Motion servo drive LXM16D 1.5 kW, 200...230 V, single phase |
| Product or Component Type | Braking resistor   |
| Ohmic value               | 27 Ohm   |

## Complementary

|                         |  |
|-------------------------|--|
| Energy peak             | 10500 J 480 V<br>11400 J 400 V<br>18100 J 230 V<br>25500 J 115 V |
| Average power available | 100 W 122 °F (50 °C)   |
| Continuous power        | 400 W  |
| Protection Type         | Thermal protection via the servo drive                           |
| Net Weight              | 3.57 lb(US) (1.62 kg)  |
| Cable length            | 9.84 ft (3 m)  |

## Environment

|                                       |                            |
|---------------------------------------|----------------------------|
| IP Degree of Protection               | IP65                       |
| Ambient Air Temperature for Storage   | -13...185 °F (-25...85 °C) |
| Ambient Air Temperature for Operation | 32...122 °F (0...50 °C)    |

## Ordering and shipping details

|                   |                             |
|-------------------|-----------------------------|
| Category          | 18263-LEXIUM 32 ACCESSORIES |
| Discount Schedule | PC51                        |
| GTIN              | 3389119207195               |
| Returnability     | No                          |
| Country of origin | DE                          |

## Packing Units

|                              |                           |
|------------------------------|---------------------------|
| Unit Type of Package 1       | PCE                       |
| Number of Units in Package 1 | 1                         |
| Package 1 Height             | 1.85 in (4.7 cm)          |
| Package 1 Width              | 4.92 in (12.5 cm)         |
| Package 1 Length             | 15.51 in (39.4 cm)        |
| Package 1 Weight             | 3.82 lb(US) (1.732 kg)    |
| Unit Type of Package 2       | S03                       |
| Number of Units in Package 2 | 6                         |
| Package 2 Height             | 11.81 in (30 cm)          |
| Package 2 Width              | 11.81 in (30 cm)          |
| Package 2 Length             | 15.75 in (40 cm)          |
| Package 2 Weight             | 24.85 lb(US) (11.273 kg)  |
| Unit Type of Package 3       | S06                       |
| Number of Units in Package 3 | 48                        |
| Package 3 Height             | 28.94 in (73.5 cm)        |
| Package 3 Width              | 23.62 in (60 cm)          |
| Package 3 Length             | 31.50 in (80 cm)          |
| Package 3 Weight             | 212.68 lb(US) (96.472 kg) |

## Offer Sustainability

|                            |   |
|----------------------------|---|
| California proposition 65  | WARNING: This product can expose you to chemicals including: Lead and lead compounds, which is known to the State of California to cause cancer and birth defects or other reproductive harm. For more information go to <a href="http://www.P65Warnings.ca.gov">www.P65Warnings.ca.gov</a> |
| REACH Regulation           | <a href="#">REACH Declaration</a>   |
| REACH free of SVHC         | Yes   |
| EU RoHS Directive          | Pro-active compliance (Product out of EU RoHS legal scope) <a href="#">EU RoHS Declaration</a>  |
| Mercury free               | Yes   |
| China RoHS Regulation      | <a href="#">China RoHS Declaration</a>  |
| RoHS exemption information | <a href="#">Yes</a>   |
| PVC free                   | Yes   |

## Contractual warranty

|          |           |
|----------|-----------|
| Warranty | 18 months |
|----------|-----------|

Braking Resistor

Dimensions

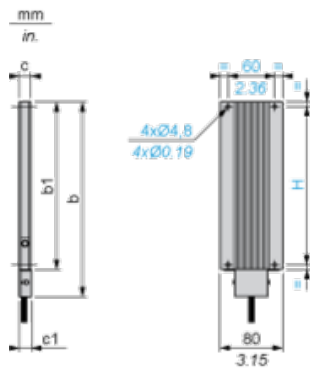

Dimensions in mm

| b   | b1  | c  | c1 | H   |
|-----|-----|----|----|-----|
| 257 | 216 | 30 | –  | 204 |

Dimensions in in.

| b     | b1   | c    | c1 | H    |
|-------|------|------|----|------|
| 10.11 | 8.50 | 1.18 | –  | 8.03 |