

ATV320U40M3C

variable speed drive, ATV320, 4 kW, 200...240 V, 3 phases, compact



Complementary

| | |
|------------------------------------|--|
| Range of product | Altivar Machine ATV320 |
| Product or component type | Variable speed drive |
| Product specific application | Complex machines |
| Device short name | ATV320 |
| Variant | Standard version |
| Format of the control block | Compact |
| Product destination | Synchronous motors Asynchronous motors |
| EMC filter | Without EMC filter |
| IP degree of protection | IP20 IEC 61800-5-1 IP20 IEC 60529 |
| Degree of protection | UL 61800-5-1 with conformity kit) |
| Type of cooling | Fan |
| Phase | 3 phase |
| [Us] rated supply voltage | 200...240 V - 15...10 % |
| Supply frequency | 50...60 Hz - 5...5 % |
| Motor power kW | 4.0 kW heavy duty |
| Maximum Horse Power Rating | 5.0 hp heavy duty |
| Line current | 23.8 A 200 V heavy duty) 19.9 A 240 V heavy duty) |
| Prospective line I _{sc} | 5 kA |
| Apparent power | 8.3 kVA 240 V heavy duty) |
| Continuous output current | 17.5 A 4 kHz heavy duty |
| Maximum transient current | 26.3 A 60 s heavy duty) |
| Power range | 4...5.5 kW |
| Asynchronous motor control profile | Voltage/Frequency ratio, 5 points Flux vector control without sensor, standard Voltage/Frequency ratio - Energy Saving, quadratic U/f Flux vector control without sensor - Energy Saving Voltage/frequency ratio, 2 points |
| Synchronous motor control profile | Vector control without sensor |
| Speed drive output frequency | 0.1...599 Hz |
| Nominal switching frequency | 4 kHz |
| Switching frequency | 2...16 kHz adjustable 4...16 kHz with derating factor |
| Safety function | STO (safe torque off) SIL 3 SLS (safe limited speed) SS1 (safe stop 1) SMS (safe maximum speed) GDL (guard door locking) |
| Communication port protocol | Modbus serial CANopen |

The information provided in this documentation contains general descriptions and/or technical characteristics of the performance of the products contained herein. This documentation is not intended as a substitute for and is not to be used for determining suitability or reliability of these products for specific user applications. It is the duty of any such user or integrator to perform the appropriate and complete risk analysis, evaluation and testing of the products with respect to the relevant specific application or use thereof. Neither Schneider Electric Industries SAS nor any of its affiliates or subsidiaries shall be responsible or liable for misuse of the information contained herein.

| | |
|-------------------------------------|---|
| Optional communication modules | Communication module, CANopen daisy chain RJ45 Communication module, CANopen SUB-D 9 Communication module, CANopen open style terminal block Communication module, EtherCAT RJ45 Communication module, DeviceNet Communication module, Ethernet/IP Communication module, Profibus DP V1 Communication module, Profinet Communication module, Ethernet Powerlink |
| Output voltage | \leq power supply voltage |
| Permissible temporary current boost | 1.5 x I_n 60 s heavy duty) |
| Speed range | 1...100 asynchronous motor in open-loop mode |
| Speed accuracy | +/- 10 % of nominal slip 0.2 T_n to T_n |
| Torque accuracy | +/- 15 % |
| Transient overtorque | 170...200 % of nominal motor torque |
| Braking torque | \leq 170 % 60 s with braking resistor |
| Regulation loop | Adjustable PID regulator |
| Motor slip compensation | Automatic whatever the load Adjustable 0...300 % Not available in voltage/frequency ratio (2 or 5 points) |
| Acceleration and deceleration ramps | Linear U S CUS Ramp switching Acceleration/Deceleration ramp adaptation Acceleration/deceleration automatic stop with DC injection |
| Braking to standstill | By DC injection |
| Protection type | Input phase breaks drive Overcurrent between output phases and earth drive Overheating protection drive Short-circuit between motor phases drive Thermal protection drive |
| Frequency resolution | Display unit 0.1 Hz Analog input 0.012/50 Hz |
| Electrical connection | Screw terminal 1.5...2.5 mm ² , AWG 10 power supply) Screw terminal 1.5...2.5 mm ² , AWG 10 DC bus) Screw terminal 1.5...2.5 mm ² , AWG 10 motor/braking resistor) Screw terminal 1.5...2.5 mm ² , AWG 20...AWG 16 control) |
| Connector type | 1 RJ45 on terminal)Modbus/CANopen |
| Physical interface | 2-wire RS 485 Modbus serial/CANopen |
| Transmission frame | RTU Modbus serial |
| Transmission rate | 4.8, 9.6, 19.2, 38.4 kbit/s Modbus serial 50 kbps, 125 kbps, 250 kbps, 500 kbps, 1 Mbps CANopen |
| Data format | 8 bits, configurable odd, even or no parity Modbus serial |
| Type of polarization | No impedance Modbus serial |
| Number of addresses | 1...127 CANopen 1...247 Modbus serial |
| Method of access | Slave CANopen |
| Supply | Internal supply for reference potentiometer (1 to 10 kOhm) 10.5 V DC +/- 5 %, <10 mA overload and short-circuit protection |
| Local signalling | CANopen run 1 LED green) CANopen error 1 LED red) Drive fault 1 LED red) |
| Maximum Width | 5.51 in (140.0 mm) |
| Height | 7.24 in (184.0 mm) |
| Maximum Depth | 6.22 in (158.0 mm) |
| Net Weight | 4.85 lb(US) (2.2 kg) |

| | |
|---------------------------|---|
| Analogue input number | 3 |
| Analogue input type | AI1 voltage 0...10 V DC 30000 Ohm 10 bits AI2 bipolar differential voltage +/- 10 V DC 30000 Ohm 10 bits AI3 current 0...20 mA (or 4-20 mA, x-20 mA, 20-x mA or other patterns by configuration) 250 Ohm 10 bits |
| Discrete input number | 7 |
| Discrete input type | Programmable (sink/source) DI1...DI4)24...30 V DC level 1 PLC Programmable as pulse input 20 kpps DI5)24...30 V DC level 1 PLC Switch-configurable PTC probe DI6)24...30 V DC Safe torque off STO)24...30 V DC - 1500 Ohm |
| Discrete input logic | Negative logic (sink) DI1...DI6), > 19 V, < 13 V Positive logic (source) DI1...DI6), < 5 V, > 11 V |
| Analogue output number | 1 |
| Analogue output type | AQ1 software-configurable current 0...20 mA 800 Ohm 10 bits AQ1 software-configurable voltage 0...10 V 470 Ohm 10 bits |
| Sampling duration | 2 Ms AI1, AI2, AI3) - analog input 2 ms AQ1) - analog output |
| Accuracy | +/- 0.2 % AI1, AI2, AI3 for a temperature of -10...60 °C analog input +/- 0.5 % AI1, AI2, AI3 for a temperature of 25 °C analog input +/- 1 % AQ1 for a temperature of 25 °C analog output +/- 2 % AQ1 for a temperature of -10...60 °C analog output |
| Linearity error | AI1, AI2, AI3 +/- 0.2...0.5 % of maximum value analog input AQ1 +/- 0.3 % analog output |
| Discrete output number | 3 |
| Discrete output type | Configurable relay logic R1A, R1B, R1C) NO/NC - 100000 cycles Configurable relay logic R2A, R2B) NO - 100000 cycles Logic LO) |
| Refresh time | Logic input DI1...DI6)8 ms +/- 0.7 ms) Relay output R1A, R1B, R1C)2 ms Relay output R2A, R2C)2 ms |
| Minimum switching current | Relay output R1, R2 5 mA 24 V DC |
| Maximum switching current | Relay output R1 resistive, cos phi = 1 3 A 250 V AC Relay output R1 resistive, cos phi = 1 4 A 30 V DC Relay output R1, R2 inductive, cos phi = 0.4 2 A 250 V AC Relay output R1, R2 inductive, cos phi = 0.4 2 A 30 V DC Relay output R2 resistive, cos phi = 1 5 A 250 V AC Relay output R2 resistive, cos phi = 1 5 A 30 V DC |
| Isolation | Between power and control terminals |
| Insulation resistance | > 1 MOhm 500 V DC for 1 minute to earth |
| Noise level | 52 dB 86/188/EEC |
| Power dissipation in W | Fan 140.0 W 200 V 4 kHz |
| Volume of cooling air | 4332.50 Gal/hr(US) (16.4 m3/h) |
| Operating position | Vertical +/- 10 degree |
| Operating altitude | <= 3280.84 ft (1000 m) without derating 3280.84...9842.52 ft (1000...3000 m) with current derating 1 % per 100 m |
| Standards | EN/IEC 61800-3 EN/IEC 61800-5-1 IEC 60721-3 IEC 61508 IEC 13849-1 UL 508C UL 61800-5-1 CSA C22.2 No 274 |

| | |
|------------------------|--|
| Product certifications | CE ATEX NOM GOST EAC RCM KC REACH |
| Marking | CE ATEX UL CSA EAC RCM |

Environment

| | |
|---------------------------------------|---|
| Electromagnetic compatibility | Electrostatic discharge immunity test level 3 IEC 61000-4-2 Radiated radio-frequency electromagnetic field immunity test level 3 IEC 61000-4-3 Electrical fast transient/burst immunity test level 4 IEC 61000-4-4 1.2/50 μ s - 8/20 μ s surge immunity test level 3 IEC 61000-4-5 Conducted radio-frequency immunity test level 3 IEC 61000-4-6 Voltage dips and interruptions immunity test IEC 61000-4-11 |
| Pollution degree | 2 EN/IEC 61800-5-1 |
| Vibration resistance | 1 gn 13...200 Hz)EN/IEC 60068-2-6 1.5 mm peak to peak 2...13 Hz)EN/IEC 60068-2-6 |
| Shock resistance | 15 gn 11 ms EN/IEC 60068-2-27 |
| Relative humidity | 5...95 % without condensation IEC 60068-2-3 5...95 % without dripping water IEC 60068-2-3 |
| Ambient air temperature for operation | 14...122 °F (-10...50 °C) without derating 122...140 °F (50...60 °C) with derating factor |
| Ambient air temperature for storage | -13...158 °F (-25...70 °C) |
| Environmental characteristic | Chemical pollution resistance class 3C3 EN/IEC 60721-3-3 Dust pollution resistance class 3S2 EN/IEC 60721-3-3 |

Ordering and shipping details

| | |
|-----------------------|--|
| Category | 22152 - ATV320/ATV312/ATV32 (.25 THRU 7.5HP) |
| Discount Schedule | CP4B |
| GTIN | 00785901556671 |
| Nbr. of units in pkg. | 1 |
| Package weight(Lbs) | 5.64 lb(US) (2.56 kg) |
| Returnability | Yes |
| Country of origin | ID |

Packing Units

| | |
|------------------------------|-------------------------|
| Unit Type of Package 1 | PCE |
| Package 1 Height | 9.65 in (24.5 cm) |
| Package 1 width | 7.48 in (19 cm) |
| Package 1 Length | 10.55 in (26.8 cm) |
| Unit Type of Package 2 | S04 |
| Number of Units in Package 2 | 2 |
| Package 2 Weight | 12.76 lb(US) (5.79 kg) |
| Package 2 Height | 11.81 in (30 cm) |
| Package 2 width | 15.75 in (40 cm) |
| Package 2 Length | 23.62 in (60 cm) |
| Unit Type of Package 3 | P06 |
| Number of Units in Package 3 | 12 |
| Package 3 Weight | 97.58 lb(US) (44.26 kg) |
| Package 3 Height | 31.50 in (80 cm) |
| Package 3 width | 31.50 in (80 cm) |
| Package 3 Length | 23.62 in (60 cm) |

Offer Sustainability

| | |
|----------------------------|--|
| EU RoHS Directive | Pro-active compliance (Product out of EU RoHS legal scope) EU RoHS Declaration |
| Mercury free | Yes |
| RoHS exemption information | Yes |
| China RoHS Regulation | China RoHS Declaration |
| Environmental Disclosure | Product Environmental Profile |
| Circularity Profile | End Of Life Information |
| WEEE | The product must be disposed on European Union markets following specific waste collection and never end up in rubbish bins. |

Dimensions

Right View, Front View and Front View with EMC Plate

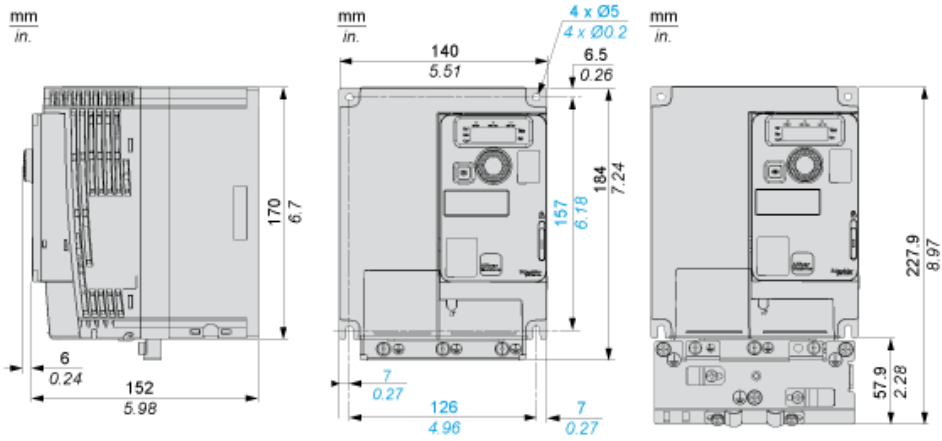

Mounting Types

Mounting Type A: Individual with Ventilation Cover

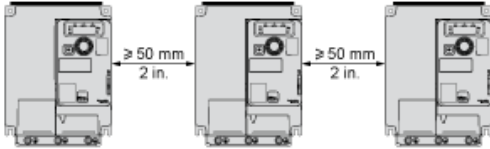

Only Possible at Ambient Temperature Less or Equal to 50 °C (122 °F)

Mounting Type B: Side by Side, Ventilation Cover Removed

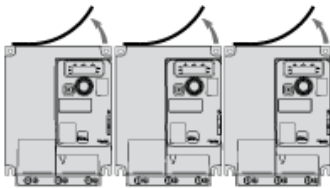

Mounting Type C: Individual, Ventilation Cover Removed

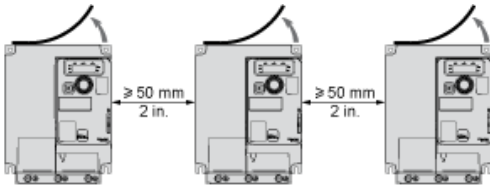

For Operation at Ambient Temperature Above 50 °C (122 °F)

Connection Diagrams

Diagram with Line Contactor

Connection diagrams conforming to standards ISO13849 category 1 and IEC/EN 61508 capacity SIL1, stopping category 0 in accordance with standard IEC/EN 60204-1.

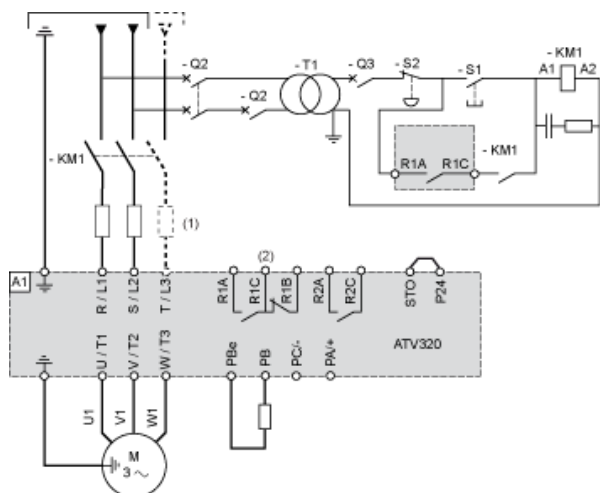

- (1) Line choke (if used)
- (2) Fault relay contacts, for remote signaling of drive status

Diagram with Switch Disconnect

Connection diagrams conforming to standards EN 954-1 category 1 and IEC/EN 61508 capacity SIL1, stopping category 0 in accordance with standard IEC/EN 60204-1.

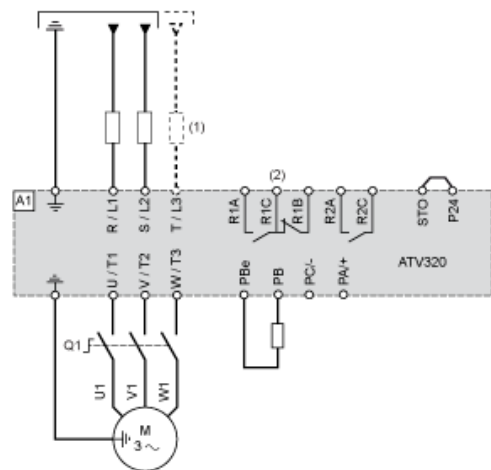

- (1) Line choke (if used)
- (2) Fault relay contacts, for remote signaling of drive status

Control Connection Diagram in Source Mode

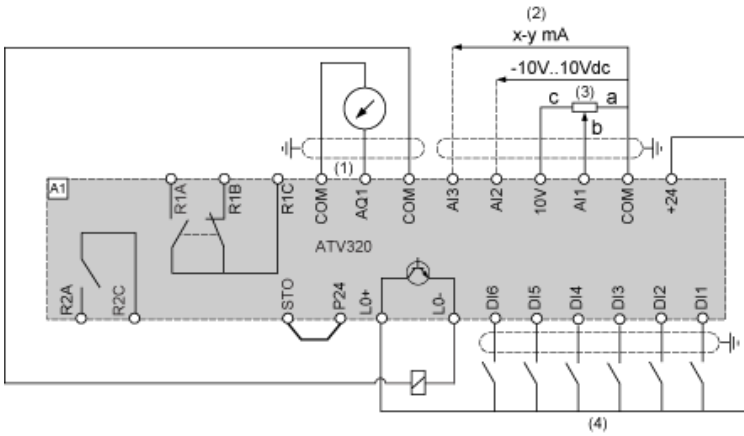

- (1) Analog output
- (2) Analog inputs
- (3) Reference potentiometer (10 kOhm maxi)
- (4) Digital inputs

Digital Inputs Wiring

The logic input switch (SW1) is used to adapt the operation of the logic inputs to the technology of the programmable controller outputs. Switch SW1 set to “Source” position and use of the output power supply for the DIs.

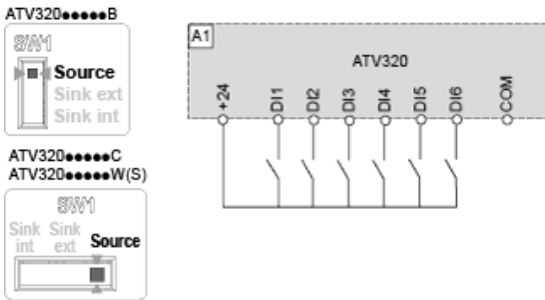

Switch SW1 set to “Source” position and use of an external power supply for the DIs.



Switch SW1 set to “Sink Int” position and use of the output power supply for the DIs.

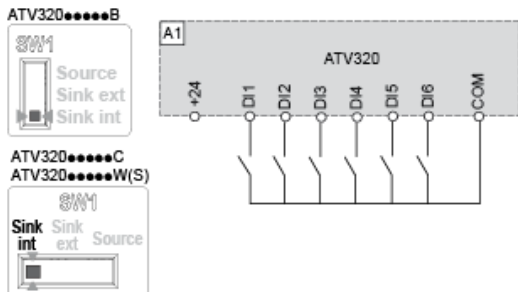

Switch SW1 set to "Sink Ext" position and use of an external power supply for the DIs.

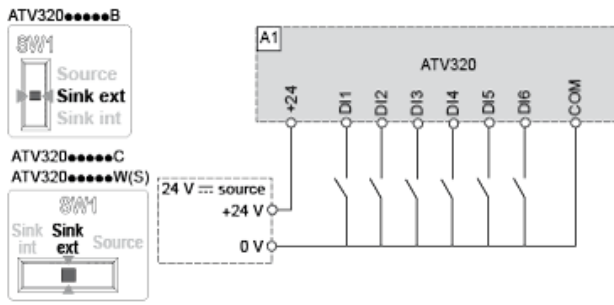

Derating Curves

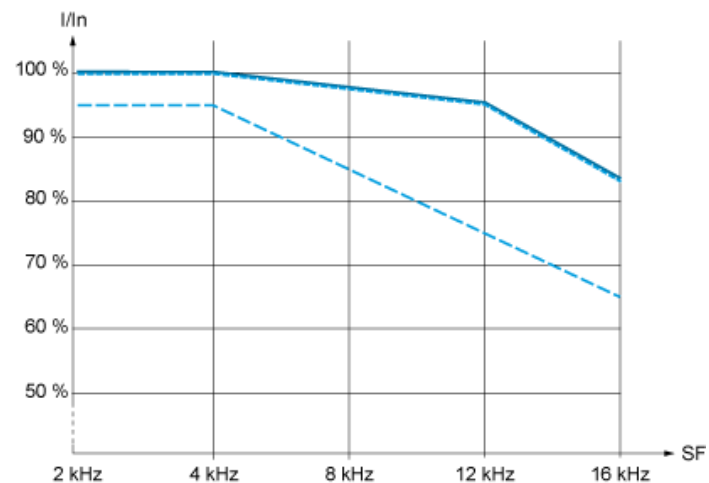

- 40 °C (104 °F) - Mounting type A, B and C
 - - - 50 °C (122 °F) - Mounting type C
 - . - 60 °C (140 °F) - Mounting type C
- In : Nominal Drive Current
SF : Switching Frequency