

# XB5KS2B4

Harmony XB5, Illuminated buzzer, plastic, red, Ø22, continuous or intermittent tone, 24 V AC/DC



## Main

Range of Product	Harmony XB5
Product or Component Type	Annunciator
Bezel material	Plastic
Mounting diameter	0.87 in (22 mm)
Cap/operator or lens colour	Red

## Complementary

[Us] rated supply voltage	24 V +/- 10 %
Supply circuit type	AC/DC
Supply frequency	50/60 Hz
Current Consumption	<= 58 mA
Signalling type	Continuous or intermittent tone
Noise level	90 dB 6.8 kHz 0.1 m +/- 10 %
Resistance to high pressure washer	1305.34 psi (9000000 Pa) 176 °F (80 °C) 0.1 m
Height	1.14 in (29 mm)
Width	1.14 in (29 mm)
Depth	2.17 in (55 mm)
Net Weight	0.05 lb(US) (0.024 kg)

## Environment

Protective treatment	TH
Ambient Air Temperature for Storage	-40...158 °F (-40...70 °C)
Ambient Air Temperature for Operation	-40...158 °F (-40...70 °C)
Overvoltage category	Class II IEC 60536
NEMA degree of protection	NEMA 4X NEMA 13
Standards	CSA C22.2 No 14 IEC 60947-5-1 EN 60947-5-4 JIS C8201-5-1 EN 60947-1 UL 508 IEC 60947-5-4 EN 60947-5-1 IEC 60947-1 JIS C8201-1 IEC 60529 EN 50102 IEC 50102
Product Certifications	UL Listed CSA BV

The information provided in this documentation contains general descriptions and/or technical characteristics of the performance of the products contained herein. This documentation is not intended as a substitute for and is not to be used for determining suitability or reliability of these products for specific user applications. It is the duty of any such user or integrator to perform the appropriate and complete risk analysis, evaluation and testing of the products with respect to the relevant specific application or use thereof. Neither Schneider Electric Industries SAS nor any of its affiliates or subsidiaries shall be responsible or liable for misuse of the information contained herein.

## Ordering and shipping details

Category	00028-DATA PORTS
Discount Schedule	CS2
GTIN	3606481352439
Returnability	Yes
Country of origin	ID

## Packing Units

Unit Type of Package 1	PCE
Number of Units in Package 1	1
Package 1 Height	1.30 in (3.3 cm)
Package 1 Width	1.34 in (3.4 cm)
Package 1 Length	2.36 in (6 cm)
Package 1 Weight	0.95 oz (27 g)
Unit Type of Package 2	S01
Number of Units in Package 2	88
Package 2 Height	5.91 in (15 cm)
Package 2 Width	5.91 in (15 cm)
Package 2 Length	15.75 in (40 cm)
Package 2 Weight	5.80 lb(US) (2.629 kg)
Unit Type of Package 3	P06
Number of Units in Package 3	1408
Package 3 Height	27.56 in (70 cm)
Package 3 Width	31.50 in (80 cm)
Package 3 Length	23.62 in (60 cm)
Package 3 Weight	94.83 lb(US) (43.016 kg)

## Offer Sustainability

Sustainable offer status	Green Premium product
California proposition 65	WARNING: This product can expose you to chemicals including: Lead and lead compounds, which is known to the State of California to cause cancer and birth defects or other reproductive harm. For more information go to <a href="http://www.P65Warnings.ca.gov">www.P65Warnings.ca.gov</a>
REACH Regulation	<a href="#">REACH Declaration</a>
EU RoHS Directive	Pro-active compliance (Product out of EU RoHS legal scope) <a href="#">EU RoHS Declaration</a>
Mercury free	Yes
China RoHS Regulation	<a href="#">China RoHS Declaration</a>
RoHS exemption information	<a href="#">Yes</a>
Environmental Disclosure	<a href="#">Product Environmental Profile</a>
WEEE	The product must be disposed on European Union markets following specific waste collection and never end up in rubbish bins.

Dimensions

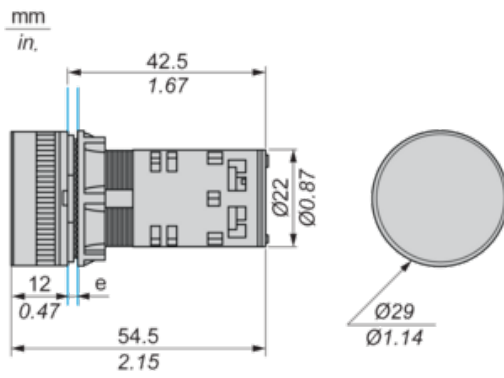

e: Clamping thickness: 1 to 6 mm / 0.04 to 0.24 in.

Panel Cut-out for Buzzer

Connection by Screw Clamp Terminals



(1) Diameter on finished panel or support

(2) Ø22.5 mm recommended ( $\text{Ø}22.3 \text{ }_0^{+0.4}$ ) / Ø0.89 in. recommended ( $\text{Ø}0.88 \text{ in. }_0^{+0.016}$ )

Connections	a in mm	a in in.	b in mm	b in in.
By screw clamp terminals or plug-in connector	40	1.57	30	1.18

---

Cabling of Annunciators

---

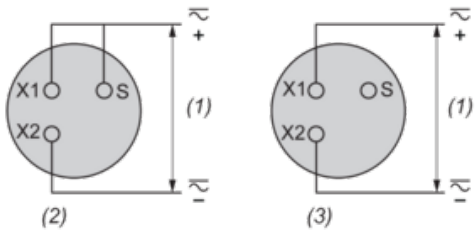

- (1) Supply
- (2) Intermittent
- (3) Continuous