

# ATV320U40N4WS

variable speed drive, ATV320, 4 kW, 380...500 V, 3 phases, enclosed



## Complementary

Number of HW interfaces other	1.0
Nominal output power	4.0 W
Number of HW interfaces serial RS232	0.0
Number of HW interfaces serial RS422	0.0
Number of HW interfaces serial RS485	1.0
Number of HW interfaces serial TTY	0.0
Number of HW interfaces USB	0.0
Number of HW interfaces industrial Ethernet	0.0
Number of HW interfaces parallel	0.0
Number of HW interfaces PROFINET	0.0
Range of product	Altivar Machine ATV320
Product or component type	Variable speed drive
Product specific application	Complex machines
Device short name	ATV320
Variant	With disconnect switch
Format of the control block	Enclosed
Product destination	Synchronous motors Asynchronous motors
EMC filter	Class C2 EMC filter integrated
IP degree of protection	IP65 IEC 61800-5-1 IP65 IEC 60529
Degree of protection	UL 61800-5-1
Type of cooling	Fanless
Phase	3 phase
[Us] rated supply voltage	380...500 V - 15...10 %
Supply frequency	50...60 Hz - 5...5 %
Motor power kW	4.0 kW heavy duty
Maximum Horse Power Rating	5.0 hp heavy duty
Line current	13.7 A 380 V heavy duty) 10.6 A 500 V heavy duty)
Prospective line I <sub>sc</sub>	5 kA
Apparent power	9.2 kVA 500 V heavy duty)
Continuous output current	9.5 A 4 kHz heavy duty
Maximum transient current	14.3 A 60 s heavy duty)
Power range	4...5.5 kW

The information provided in this documentation contains general descriptions and/or technical characteristics of the performance of the products contained herein. This documentation is not intended as a substitute for and is not to be used for determining suitability or reliability of these products for specific user applications. It is the duty of any such user or integrator to perform the appropriate and complete risk analysis, evaluation and testing of the products with respect to the relevant specific application or use thereof. Neither Schneider Electric Industries SAS nor any of its affiliates or subsidiaries shall be responsible or liable for misuse of the information contained herein.

Asynchronous motor control profile	Voltage/Frequency ratio, 5 points Flux vector control without sensor, standard Voltage/Frequency ratio - Energy Saving, quadratic U/f Flux vector control without sensor - Energy Saving Voltage/frequency ratio, 2 points
Synchronous motor control profile	Vector control without sensor
Speed drive output frequency	0.1...599 Hz
Nominal switching frequency	4 kHz
Switching frequency	2...16 kHz adjustable 4...16 kHz with derating factor
Safety function	STO (safe torque off) SIL 3 SLS (safe limited speed) SS1 (safe stop 1) SMS (safe maximum speed) GDL (guard door locking)
Communication port protocol	Modbus serial CANopen
Optional communication modules	Communication module, CANopen daisy chain RJ45 Communication module, CANopen SUB-D 9 Communication module, CANopen open style terminal block Communication module, EtherCAT RJ45 Communication module, DeviceNet Communication module, Ethernet/IP Communication module, Profibus DP V1 Communication module, Profinet Communication module, Ethernet Powerlink
Output voltage	<= power supply voltage
Permissible temporary current boost	1.5 x I <sub>n</sub> 60 s heavy duty)
Speed range	1...100 asynchronous motor in open-loop mode
Speed accuracy	+/- 10 % of nominal slip 0.2 T <sub>n</sub> to T <sub>n</sub>
Torque accuracy	+/- 15 %
Transient overtorque	170...200 % of nominal motor torque
Braking torque	<= 170 % 60 s with braking resistor
Regulation loop	Adjustable PID regulator
Motor slip compensation	Automatic whatever the load Adjustable 0...300 % Not available in voltage/frequency ratio (2 or 5 points)
Acceleration and deceleration ramps	Linear U S CUS Ramp switching Acceleration/Deceleration ramp adaptation Acceleration/deceleration automatic stop with DC injection
Braking to standstill	By DC injection
Protection type	Input phase breaks drive Overcurrent between output phases and earth drive Overheating protection drive Short-circuit between motor phases drive Thermal protection drive
Frequency resolution	Display unit 0.1 Hz Analog input 0.012/50 Hz
Electrical connection	Screw terminal 4...6 mm <sup>2</sup> , AWG 12...AWG 10 power supply) Screw terminal 2.5...6 mm <sup>2</sup> , AWG 14...AWG 10 DC bus) Screw terminal 2.5...6 mm <sup>2</sup> , AWG 14...AWG 10 motor/braking resistor) Screw terminal 0.5...1.5 mm <sup>2</sup> , AWG 20...AWG 16 control)
Connector type	1 RJ45 on terminal)Modbus/CANopen
Physical interface	2-wire RS 485 Modbus serial/CANopen

Transmission frame	RTU Modbus serial
Transmission rate	4.8, 9.6, 19.2, 38.4 kbit/s Modbus serial 50 kbps, 125 kbps, 250 kbps, 500 kbps, 1 Mbps CANopen
Data format	8 bits, configurable odd, even or no parity Modbus serial
Type of polarization	No impedance Modbus serial
Number of addresses	1...127 CANopen 1...247 Modbus serial
Method of access	Slave CANopen
Supply	Internal supply for reference potentiometer (1 to 10 kOhm) 10.5 V DC +/- 5 %, <10 mA overload and short-circuit protection
Local signalling	CANopen run 1 LED green) CANopen error 1 LED red) Drive fault 1 LED red)
Maximum Width	9.84 in (250.0 mm)
Height	13.39 in (340.0 mm)
Maximum Depth	9.25 in (235.0 mm)
Net Weight	18.08 lb(US) (8.2 kg)
Analogue input number	3
Analogue input type	AI1 voltage 0...10 V DC 30000 Ohm 10 bits AI2 bipolar differential voltage +/- 10 V DC 30000 Ohm 10 bits AI3 current 0...20 mA (or 4-20 mA, x-20 mA, 20-x mA or other patterns by configuration) 250 Ohm 10 bits
Discrete input number	7
Discrete input type	Programmable (sink/source) DI1...DI4)24...30 V DC level 1 PLC Programmable as pulse input 20 kpps DI5)24...30 V DC level 1 PLC Switch-configurable PTC probe DI6)24...30 V DC Safe torque off STO)24...30 V DC - 1500 Ohm
Discrete input logic	Negative logic (sink) DI1...DI6), > 19 V, < 13 V Positive logic (source) DI1...DI6), < 5 V, > 11 V
Analogue output number	1
Analogue output type	AQ1 software-configurable current 0...20 mA 800 Ohm 10 bits AQ1 software-configurable voltage 0...10 V 470 Ohm 10 bits
Sampling duration	2 Ms AI1, AI2, AI3) - analog input 2 ms AQ1) - analog output
Accuracy	+/- 0.2 % AI1, AI2, AI3 for a temperature of -10...60 °C analog input +/- 0.5 % AI1, AI2, AI3 for a temperature of 25 °C analog input +/- 1 % AQ1 for a temperature of 25 °C analog output +/- 2 % AQ1 for a temperature of -10...60 °C analog output
Linearity error	AI1, AI2, AI3 +/- 0.2...0.5 % of maximum value analog input AQ1 +/- 0.3 % analog output
Discrete output number	3
Discrete output type	Configurable relay logic R1A, R1B, R1C) NO/NC - 100000 cycles Configurable relay logic R2A, R2B) NO - 100000 cycles Logic LO)
Refresh time	Logic input DI1...DI6)8 ms +/- 0.7 ms) Relay output R1A, R1B, R1C)2 ms Relay output R2A, R2C)2 ms
Minimum switching current	Relay output R1, R2 5 mA 24 V DC

Maximum switching current	Relay output R1 resistive, cos phi = 1 3 A 250 V AC Relay output R1 resistive, cos phi = 1 4 A 30 V DC Relay output R1, R2 inductive, cos phi = 0.4 2 A 250 V AC Relay output R1, R2 inductive, cos phi = 0.4 2 A 30 V DC Relay output R2 resistive, cos phi = 1 5 A 250 V AC Relay output R2 resistive, cos phi = 1 5 A 30 V DC
Isolation	Between power and control terminals
Insulation resistance	> 1 MOhm 500 V DC for 1 minute to earth
Noise level	0.0 dB 86/188/EEC
Power dissipation in W	Self-cooled 111.0 W 380 V 4 kHz
Operating position	Vertical +/- 10 degree
Operating altitude	<= 3280.84 ft (1000 m) without derating 3280.84...9842.52 ft (1000...3000 m) with current derating 1 % per 100 m
Standards	EN/IEC 61800-3 Environment 1 category C2 EN/IEC 61800-3 Environment 2 category C3 EN/IEC 61800-3 EN/IEC 61800-5-1 IEC 60721-3 IEC 61508 IEC 13849-1 UL 508C UL 61800-5-1 CSA C22.2 No 274
Product certifications	CE ATEX NOM GOST EAC RCM KC REACH
Marking	CE ATEX UL CSA EAC RCM

## Environment

Electromagnetic compatibility	Electrostatic discharge immunity test level 3 IEC 61000-4-2 Radiated radio-frequency electromagnetic field immunity test level 3 IEC 61000-4-3 Electrical fast transient/burst immunity test level 4 IEC 61000-4-4 1.2/50 $\mu$ s - 8/20 $\mu$ s surge immunity test level 3 IEC 61000-4-5 Conducted radio-frequency immunity test level 3 IEC 61000-4-6 Voltage dips and interruptions immunity test IEC 61000-4-11
Pollution degree	3 EN/IEC 61800-5-1
Vibration resistance	1 gn 13...200 Hz)EN/IEC 60068-2-6 1.5 mm peak to peak 2...13 Hz)EN/IEC 60068-2-6
Shock resistance	15 gn 11 ms EN/IEC 60068-2-27
Relative humidity	5...95 % without condensation IEC 60068-2-3 5...95 % without dripping water IEC 60068-2-3
Ambient air temperature for operation	14...104 °F (-10...40 °C) without derating 104...140 °F (40...60 °C) with derating factor
Ambient air temperature for storage	-13...158 °F (-25...70 °C)
Environmental characteristic	Chemical pollution resistance class 3C3 EN/IEC 60721-3-3 Dust pollution resistance class 3S2 EN/IEC 60721-3-3

## Ordering and shipping details

Category	22152 - ATV320/ATV312/ATV32 (.25 THRU 7.5HP)
Discount Schedule	CP4B
GTIN	03606489548704
Nbr. of units in pkg.	1
Package weight(Lbs)	18.07 lb(US) (8.20 kg)
Returnability	Yes

## Packing Units

Unit Type of Package 1	PCE
Package 1 Height	11.54 in (29.3 cm)
Package 1 width	12.01 in (30.5 cm)
Package 1 Length	17.72 in (45 cm)

## Offer Sustainability

EU RoHS Directive	Pro-active compliance (Product out of EU RoHS legal scope) <a href="#">EU RoHS Declaration</a>
Mercury free	Yes
RoHS exemption information	<a href="#">Yes</a>
China RoHS Regulation	<a href="#">China RoHS Declaration</a>
WEEE	The product must be disposed on European Union markets following specific waste collection and never end up in rubbish bins.

Dimensions

Front and Left View

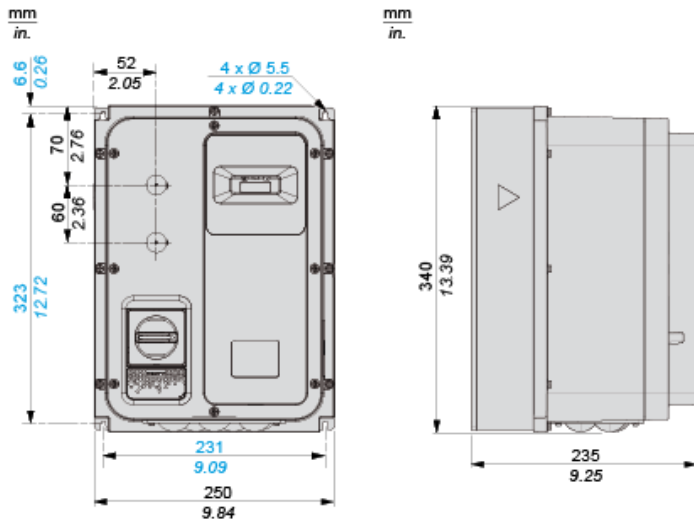

Mounting and Clearance

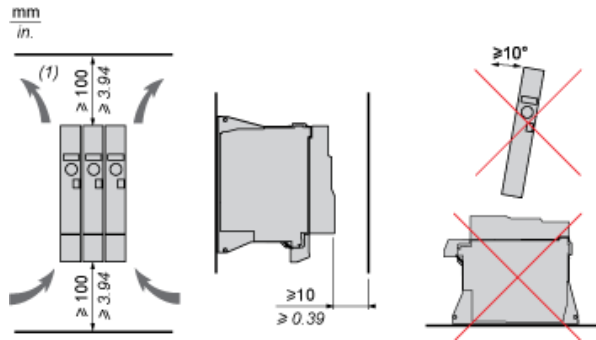

(1) Minimum value corresponding to thermal constraints.

Connection Diagrams

Diagram with Line Contactor

Connection diagrams conforming to standards ISO13849 category 1 and IEC/EN 61508 capacity SIL1, stopping category 0 in accordance with standard IEC/EN 60204-1.

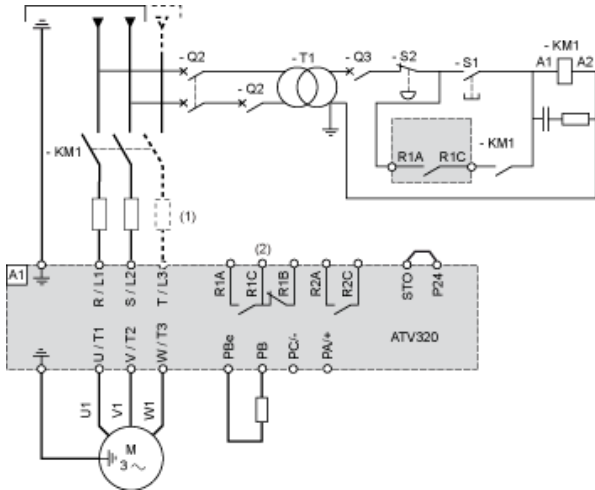

- (1) Line choke (if used)
- (2) Fault relay contacts, for remote signaling of drive status

Diagram with Switch Disconnect

Connection diagrams conforming to standards EN 954-1 category 1 and IEC/EN 61508 capacity SIL1, stopping category 0 in accordance with standard IEC/EN 60204-1.

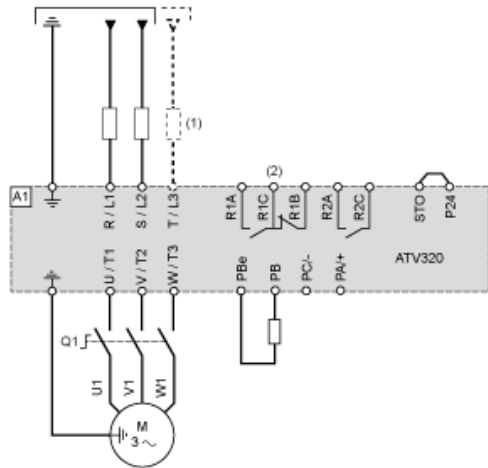

- (1) Line choke (if used)
- (2) Fault relay contacts, for remote signaling of drive status

Control Connection Diagram in Source Mode

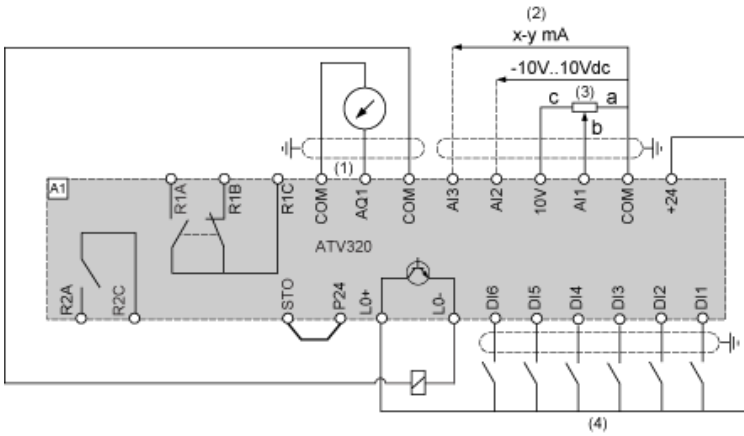

- (1) Analog output
- (2) Analog inputs
- (3) Reference potentiometer (10 kOhm maxi)
- (4) Digital inputs

## Digital Inputs Wiring

The logic input switch (SW1) is used to adapt the operation of the logic inputs to the technology of the programmable controller outputs. Switch SW1 set to “Source” position and use of the output power supply for the DIs.

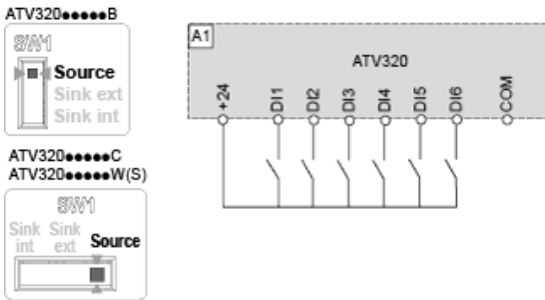

Switch SW1 set to “Source” position and use of an external power supply for the DIs.



Switch SW1 set to “Sink Int” position and use of the output power supply for the DIs.

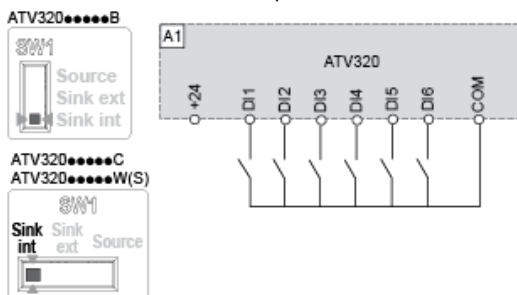

Switch SW1 set to "Sink Ext" position and use of an external power supply for the DIs.

