

STEEL HOLE CUTTERS

Quick Change Stainless Steel Hole Cutters



- Cuts stainless steel quickly and easily
- Quick Change arbor allows you to change cutter heads with a simple push and a turn - Use the same arbor for different size cutting heads
- Removable cutter heads available in sizes from 3/4" through 3"
- Flange stop prevents over-drilling
- Ejector spring on all sizes above 3/4" makes removal of slug easier
- Replaceable, cobalt-steel pilot drill with split-point tip to prevent walking
- Precision carbide teeth for optimum performance and durability
- Minimum chuck size of 3/8"
- Precision engineered and manufactured - no annoying chattering and squealing while cutting
- Improved carbide quality for more durability and longer life

KITS

CAT. NO.	UPC NO.	DESCRIPTION
660	05766	7/8", 1-1/8", 1-3/8", 1-3/4", 2" Cutter Heads; Arbor, Hex Key and Case
655	05820	7/8", 1-1/8", 1-3/8" Cutter Heads; Arbor, Hex Key and Case
[R] 03581	03581	3 mm Hex Key
[R] 54274	54274	Set Screw
[R] 55225	55225	1/2" Ejector Spring

NOTE: TO EXTEND THE LIFE OF YOUR TOOL, SEE CUTTING/THREADING OIL ON PAGE 223

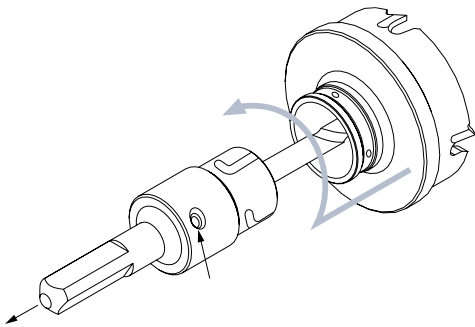

SPECIFICATIONS

Maximum Cutting Depth 8 ga. (4 mm)

INDIVIDUAL CARBIDE-TIPPED HOLE CUTTERS

CAT. NO.	UPC NO.	SIZE		CONDUIT SIZE	MIN. CHUCK SIZE		KIT CAT. NO. 660/UPC NO. 05766	KIT CAT. NO. 655/UPC NO. 05820
		INCH	MM		INCH	MM		
645-3/4	05693	3/4	19.0		3/8	9.5		
645-7/8	05695	7/8	22.2	1/2"	3/8	9.5	✓	✓
645-1	05696	1	25.4		25	3/8	9.5	
645-1-1/8	05697	1-1/8	28.6	3/4"	21	3/8	9.5	✓
645-1-7/32	05698	1-7/32	31.0			3/8	9.5	
645-1-1/4	05699	1-1/4	31.8			3/8	9.5	
645-1-3/8	05700	1-3/8	34.9	1"		3/8	9.5	✓
645-1-1/2	05701	1-1/2	38.1			3/8	9.5	
645-1-3/4	05702	1-3/4	44.4	1-1/4"		3/8	9.5	✓
645-2	05703	2	50.8	1-1/2"	50	3/8	9.5	✓
645-2-1/2	05705	2-1/2	63.5	2"	63	3/8	9.5	
645-3	05707	3	76.2			3/8	9.5	

ARBORS AND PILOT DRILLS

CAT. NO.	UPC NO.	DESCRIPTION	Kit Cat. no. 660/UPC No. 05766	Kit Cat. no. 655/UPC No. 05820
645-011	05752	Quick Change Arbor for sizes 5/8" through 2-1/4", 3/8" shank	✓	✓
645-022	05753	Quick Change Arbor for sizes 2-3/8" through 3", 1/2" shank		
645-001	05761	Pilot Drill for sizes 5/8" through 2-1/4"		
645-002	05762	Pilot Drill for sizes 2-3/8" through 3"	✓	✓
55225	55225	Ejector Spring		