





Main

| | |
|------------------------------------|--|
| Range of product | Altivar Process ATV900 |
| Product or component type | Variable speed drive |
| Device application | Industrial application |
| Device short name | ATV930 |
| Variant | With braking chopper Standard version |
| Product destination | Asynchronous motors Synchronous motors |
| Mounting mode | Wall mount |
| EMC filter | Integrated 82.02 ft (25 m) EN/IEC 61800-3 category C3 |
| IP degree of protection | IP00 IEC 61800-5-1 IP00 IEC 60529 IP20 IEC 61800-5-1 with kit VW3A9705 IP20 IEC 60529 with kit VW3A9705 |
| Type of cooling | Forced convection |
| Supply frequency | 50...60 Hz +/- 5 % |
| Phase | 3 phase |
| [Us] rated supply voltage | 500...690 V - 15...10 % |
| Motor power kW | 5.5 KW 500 V normal duty) 4 KW 500 V heavy duty) 7.5 KW 690 V normal duty) 5.5 kW 690 V heavy duty) |
| Maximum Horse Power Rating | 7.5 Hp 500 V normal duty 5 Hp 500 V heavy duty 10 Hp 690 V normal duty 7.5 hp 690 V heavy duty |
| Line current | 10.4 A 500 V normal duty) 10.5 A 690 V normal duty) 7.9 A 500 V heavy duty) 8 A 690 V heavy duty) |
| Prospective line Isc | 70 kA |
| Apparent power | 12.5 KVA 690 V normal duty) 9.6 kVA 690 V heavy duty) |
| Continuous output current | 7.2 A 4 kHz heavy duty 9.5 A 4 kHz normal duty |
| Maximum transient current | 10.8 A 60 s heavy duty) 11.4 A 60 s normal duty) |
| Asynchronous motor control profile | Optimized torque mode Constant torque standard Variable torque standard |
| Synchronous motor control profile | Permanent magnet motor Synchronous reluctance motor |
| Speed drive output frequency | 0.1...599 Hz |
| Nominal switching frequency | 4 kHz |
| Switching frequency | 2...8 kHz adjustable 4...8 kHz with derating factor |
| Safety function | STO (safe torque off) SIL 3 |
| Number of preset speeds | 16 preset speeds |

| | |
|-----------------------------|--|
| Communication port protocol | Modbus TCP Ethernet/IP Modbus serial |
| Option module | Slot A communication module Profibus DP V1 Slot A communication module Profinet Slot A communication module DeviceNet Slot A communication module EtherCAT Slot A communication module CANopen daisy chain RJ45 Slot A communication module CANopen SUB-D 9 Slot A communication module CANopen screw terminals Slot A/slot B/slot C digital and analog I/O extension module Slot A/slot B/slot C output relay extension module Slot B 5/12 V digital encoder interface module Slot B analog encoder interface module Slot B resolver encoder interface module Communication module Ethernet Powerlink |

Complementary

| | |
|-------------------------------------|--|
| Output voltage | \leq power supply voltage |
| Motor slip compensation | Automatic whatever the load Not available in permanent magnet motor law Can be suppressed Adjustable |
| Acceleration and deceleration ramps | Linear adjustable separately from 0.01...9999 s S, U or customized |
| Braking to standstill | By DC injection |
| Protection type | Thermal protection motor Safe torque off motor Motor phase break motor Thermal protection drive Safe torque off drive Overheating drive Overcurrent between output phases and earth drive Overload of output voltage drive Short-circuit protection drive Motor phase break drive Overvoltages on the DC bus drive Line supply overvoltage drive Line supply undervoltage drive Line supply phase loss drive Overspeed drive Break on the control circuit drive |
| Frequency resolution | Display unit 0.1 Hz Analog input 0.012/50 Hz |
| Electrical connection | Control screw terminal 0.5...1.5 mm ² AWG 20...AWG 16 DC bus screw terminal 4...10 mm ² AWG 12...AWG 8 Line side screw terminal 4...10 mm ² AWG 12...AWG 8 Motor screw terminal 4...10 mm ² AWG 12...AWG 8 |
| Connector type | 2 RJ45 Ethernet IP/Modbus TCP on the control block 1 RJ45 Modbus serial on the control block |
| Physical interface | 2-wire RS 485 Modbus serial |
| Transmission frame | RTU Modbus serial |
| Transmission rate | 10/100 Mbit/s Ethernet IP/Modbus TCP 4.8, 9.6, 19.2, 38.4 kbit/s Modbus serial |
| Exchange mode | Half duplex, full duplex, autonegotiation Ethernet IP/Modbus TCP |
| Data format | 8 bits, configurable odd, even or no parity Modbus serial |
| Type of polarization | No impedance Modbus serial |
| Number of addresses | 1...247 Modbus serial |
| Method of access | Slave Modbus TCP |
| Supply | External supply for digital inputs 24 V DC 19...30 V), <1.25 mA overload and short-circuit protection Internal supply for reference potentiometer (1 to 10 kOhm) 10.5 V DC +/- 5 %, <10 mA overload and short-circuit protection Internal supply for digital inputs and STO 24 V DC 21...27 V), <200 mA overload and short-circuit protection |

| | |
|---------------------------|--|
| Local signalling | Local diagnostic 3 LED mono/dual colour) Presence of voltage 1 LED red) Embedded communication status 3 LED dual colour) Communication module status 4 LED dual colour) |
| Width | 9.69 in (246 mm) |
| Height | 16.54 in (420 mm) |
| Depth | 9.53 in (242 mm) |
| Net weight | 48.50 lb(US) (22 kg) |
| Analogue input number | 3 |
| Analogue input type | AI1, AI2, AI3 software-configurable voltage 0...10 V DC 30 kOhm 12 bits AI1, AI2, AI3 software-configurable current 0...20 mA/4...20 mA 250 Ohm 12 bits |
| Discrete input number | 10 |
| Discrete input type | DI1...DI8 programmable, 24 V DC <= 30 V)3.5 kOhm DI7, DI8 programmable as pulse input 0...30 kHz, 24 V DC <= 30 V) STOA, STOB safe torque off, 24 V DC <= 30 V)> 2.2 kOhm |
| Input compatibility | DI1...DI8 discrete input level 1 PLC EN/IEC 61131-2 DI7, DI8 pulse input level 1 PLC IEC 65A-68 STOA, STOB discrete input level 1 PLC EN/IEC 61131-2 |
| Discrete input logic | Positive logic (source) DI1...DI8), < 5 V, > 11 V Negative logic (sink) DI1...DI8), > 16 V, < 10 V Positive logic (source) DI7, DI8), < 0.6 V, > 2.5 V Positive logic (source) STOA, STOB), < 5 V, > 11 V |
| Analogue output number | 2 |
| Analogue output type | Software-configurable voltage AQ1, AQ2 0...10 V DC 470 Ohm 10 bits Software-configurable current AQ1, AQ2 0...20 mA 500 Ohm 10 bits |
| Discrete output number | 2 |
| Discrete output type | Logic output DQ+ 0...1 kHz <= 30 V DC 100 mA Programmable as pulse output DQ+ 0...30 kHz <= 30 V DC 20 mA Logic output DQ- 0...1 kHz <= 30 V DC 100 mA |
| Sampling duration | 2 Ms +/- 0.5 ms DI1...DI8) - discrete input 5 Ms +/- 1 ms DI7, DI8) - pulse input 1 Ms +/- 1 ms AI1, AI2, AI3) - analog input 5 ms +/- 1 ms AQ1, AQ2) - analog output |
| Accuracy | +/- 0.6 % AI1, AI2, AI3 for a temperature variation 60 °C analog input +/- 1 % AQ1, AQ2 for a temperature variation 60 °C analog output |
| Linearity error | AI1, AI2, AI3 +/- 0.15 % of maximum value analog input AQ1, AQ2 +/- 0.2 % analog output |
| Maximum switching current | Relay output R1 resistive, cos phi = 1 3 A 250 V AC Relay output R1 resistive, cos phi = 1 3 A 30 V DC Relay output R1 inductive, cos phi = 0.4 7 ms 2 A 250 V AC Relay output R1 inductive, cos phi = 0.4 7 ms 2 A 30 V DC Relay output R2, R3 resistive, cos phi = 1 5 A 250 V AC Relay output R2, R3 resistive, cos phi = 1 5 A 30 V DC Relay output R2, R3 inductive, cos phi = 0.4 7 ms 2 A 250 V AC Relay output R2, R3 inductive, cos phi = 0.4 7 ms 2 A 30 V DC |
| Relay output number | 3 |
| Relay output type | Configurable relay logic R1 fault relay NO/NC 100000 cycles Configurable relay logic R2 sequence relay NO 1000000 cycles Configurable relay logic R3 sequence relay NO 1000000 cycles |
| Refresh time | Relay output R1, R2, R3)5 ms +/- 0.5 ms) |
| Minimum switching current | Relay output R1, R2, R3 5 mA 24 V DC |
| Isolation | Between power and control terminals |

Environment

| | |
|------------------------|---|
| Insulation resistance | > 1 MOhm 500 V DC for 1 minute to earth |
| Noise level | 58 dB 86/188/EEC |
| Power dissipation in W | Forced convection 136 W 500 V 4 kHz Natural convection 88 W 500 V 4 kHz |
| Vibration resistance | 1.5 mm peak to peak 2...13 Hz)IEC 60068-2-6 1 gn 13...200 Hz)IEC 60068-2-6 |
| Shock resistance | 15 gn 11 ms IEC 60068-2-27 |
| Volume of cooling air | 87178.34 Gal/hr(US) (330 m3/h) |
| Operating position | Vertical +/- 10 degree |

| | |
|---------------------------------------|--|
| Electromagnetic compatibility | Electrostatic discharge immunity test level 3 IEC 61000-4-2 Radiated radio-frequency electromagnetic field immunity test level 3 IEC 61000-4-3 Electrical fast transient/burst immunity test level 4 IEC 61000-4-4 1.2/50 µs - 8/20 µs surge immunity test level 3 IEC 61000-4-5 Conducted radio-frequency immunity test level 3 IEC 61000-4-6 |
| Environmental characteristic | Chemical pollution resistance class 3C3 EN/IEC 60721-3-3 Dust pollution resistance class 3S3 EN/IEC 60721-3-3 |
| Pollution degree | 2 EN/IEC 61800-5-1 |
| Relative humidity | 5...95 % without condensation IEC 60068-2-3 |
| Ambient air temperature for operation | 5...122 °F (-15...50 °C) without 122...140 °F (50...60 °C) with derating factor) |
| Ambient air temperature for storage | -40...158 °F (-40...70 °C) |
| Operating altitude | <= 3280.84 ft (1000 m) without 1000...4800 m with current derating 1 % per 100 m |
| Standards | UL 508C EN/IEC 61800-3 Environment 2 category C3 EN/IEC 61800-3 EN/IEC 61800-5-1 IEC 61000-3-12 IEC 60721-3 IEC 61508 IEC 13849-1 |
| Product certifications | CSA REACH UL TÜV |
| Marking | CE |

Ordering and shipping details

| | |
|---------------------|-----------------------------|
| Category | 22276 - ATV930 FRAMES 1 & 2 |
| Discount Schedule | CP4E |
| GTIN | 00785901022541 |
| Package weight(Lbs) | 9525.43 kg (21000 lb(US)) |
| Returnability | Yes |

Offer Sustainability

| | |
|----------------------------|---|
| Sustainable offer status | Green Premium product |
| California proposition 65 | WARNING: This product can expose you to chemicals including: Lead and lead compounds which is known to the State of California to cause Carcinogen & Reproductive harm. For more information go to www.p65warnings.ca.gov |
| REACH Regulation | REACH Declaration |
| EU RoHS Directive | Pro-active compliance (Product out of EU RoHS legal scope) EU RoHS Declaration |
| Mercury free | Yes |
| RoHS exemption information | Yes |
| China RoHS Regulation | China RoHS Declaration |
| Environmental Disclosure | Product Environmental Profile |
| Circularity Profile | End Of Life Information |
| WEEE | The product must be disposed on European Union markets following specific waste collection and never end up in rubbish bins. |

Dimensions

Drives without Top Cover

Front View with EMC Plate, Front, Left and Rear View without EMC Plate

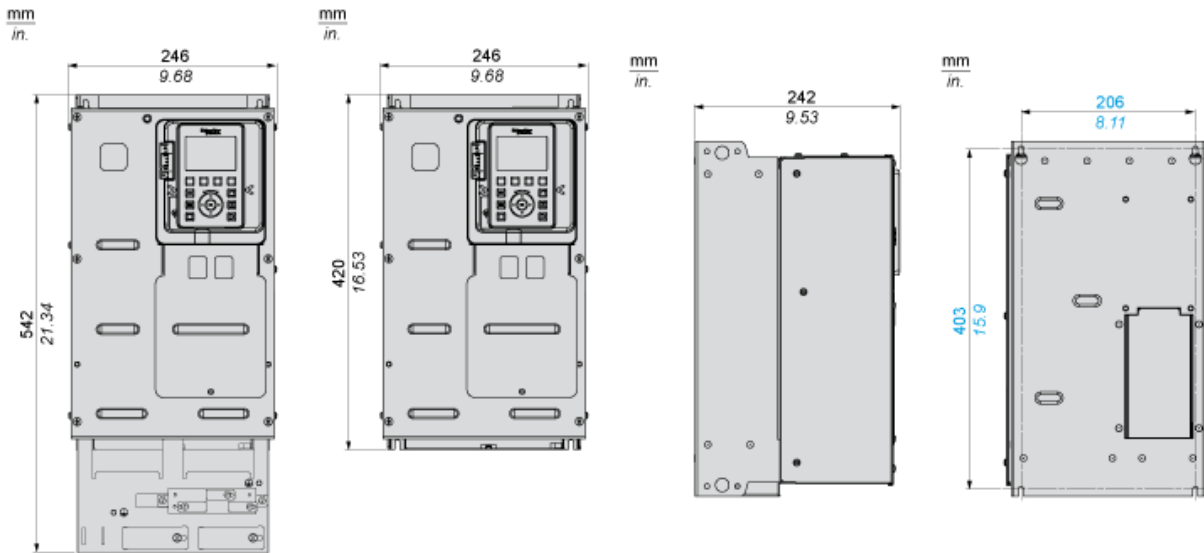

Drives with IP20 Top Cover

Front, Left and Rear View

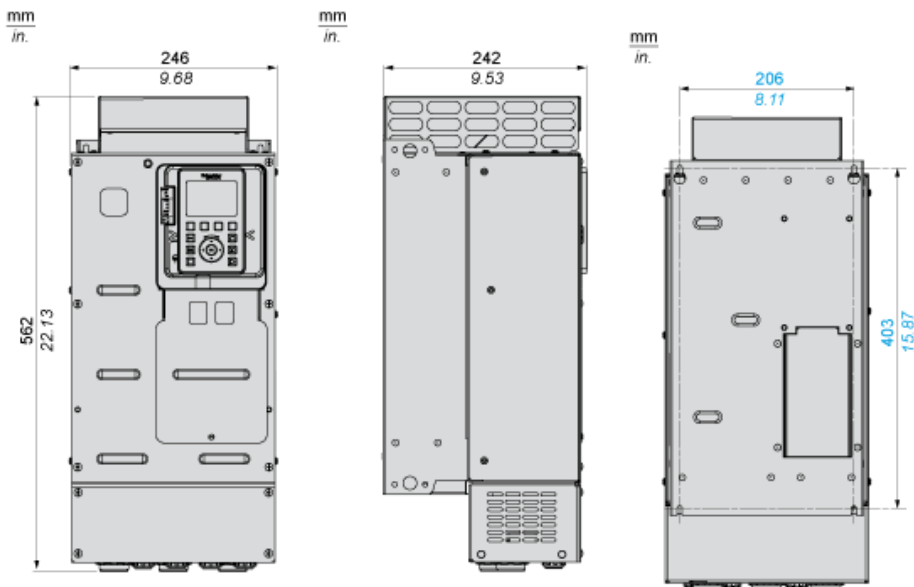

Clearances

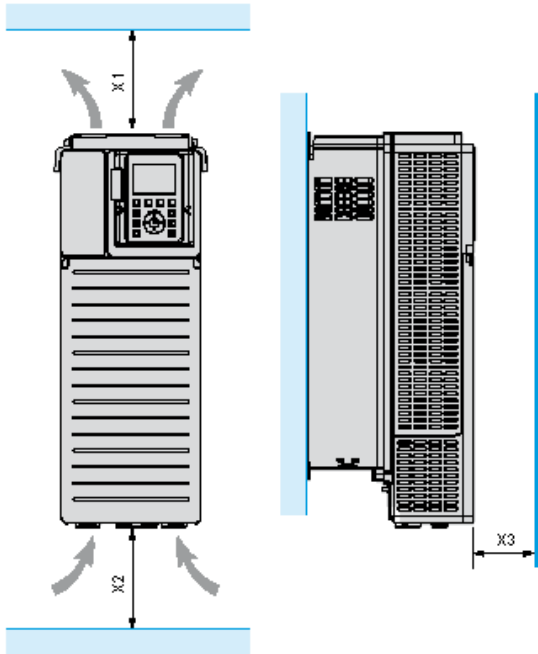

| X1 | X2 | X3 |
|---------------------|---------------------|--------------------|
| ≥ 100 mm (3.94 in.) | ≥ 100 mm (3.94 in.) | ≥ 10 mm (0.39 in.) |

- Mount the device in a vertical position ($\pm 10^\circ$). This is required for cooling the device.
- Do not mount the device close to heat sources.
- Leave sufficient free space so that the air required for cooling purposes can circulate from the bottom to the top of the drive.

Mounting Types

Mounting Type A: Individual IP21

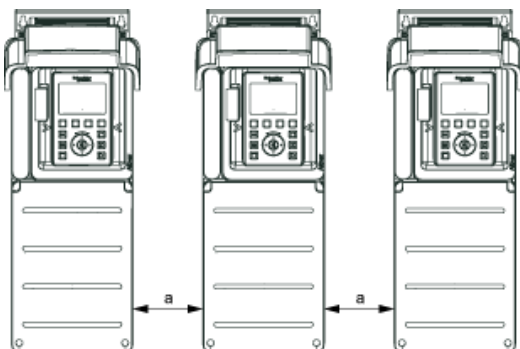

$a \geq 0$

Mounting Type B: Side by Side IP20

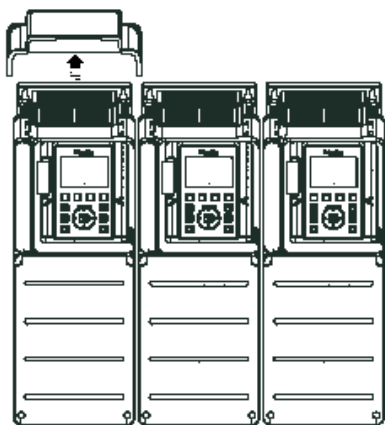

Mounting Type C: Individual IP20

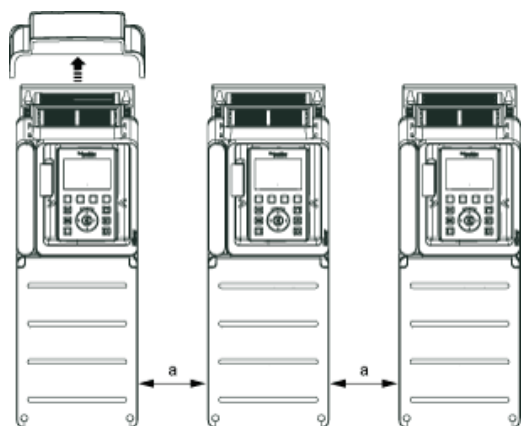

$a \geq 0$

Three-Phase Power Supply with Upstream Breaking via Line Contactor

Connection diagrams conforming to standards EN 954-1 category 1 and IEC/EN 61508 capacity SIL1, stopping category 0 in accordance with standard IEC/EN 60204-1

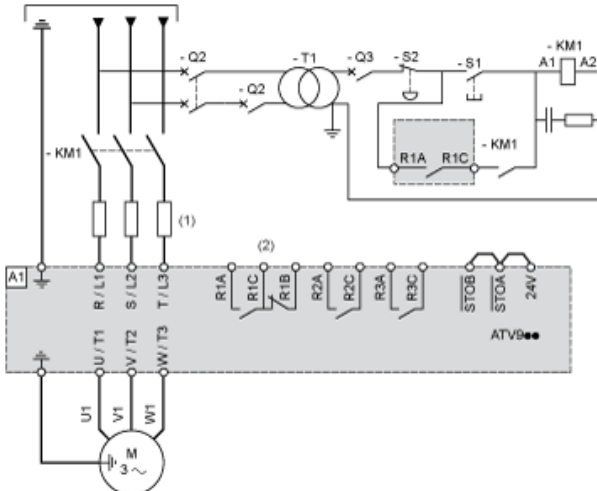

- (1) Line choke if used
- (2) Use relay R1 set to operating state Fault to switch Off the product once an error is detected.
- A1 : Drive
- KM1 Line Contactor
- Q2, Circuit breakers
- Q3 :
- S1, Pushbuttons
- S2 :
- T1 : Transformer for control part

Three-Phase Power Supply with Downstream Breaking via Contactor

Connection diagrams conforming to standards EN 954-1 category 1 and IEC/EN 61508 capacity SIL1, stopping category 0 in accordance with standard IEC/EN 60204-1

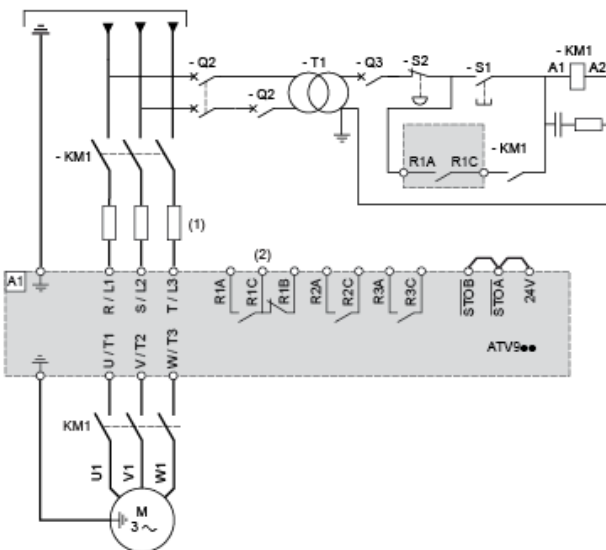

- (1) Line choke if used
- (2) Use relay R1 set to operating state Fault to switch Off the product once an error is detected.
- A1 : Drive
- KM1 :Contactor

Control Block Wiring Diagram

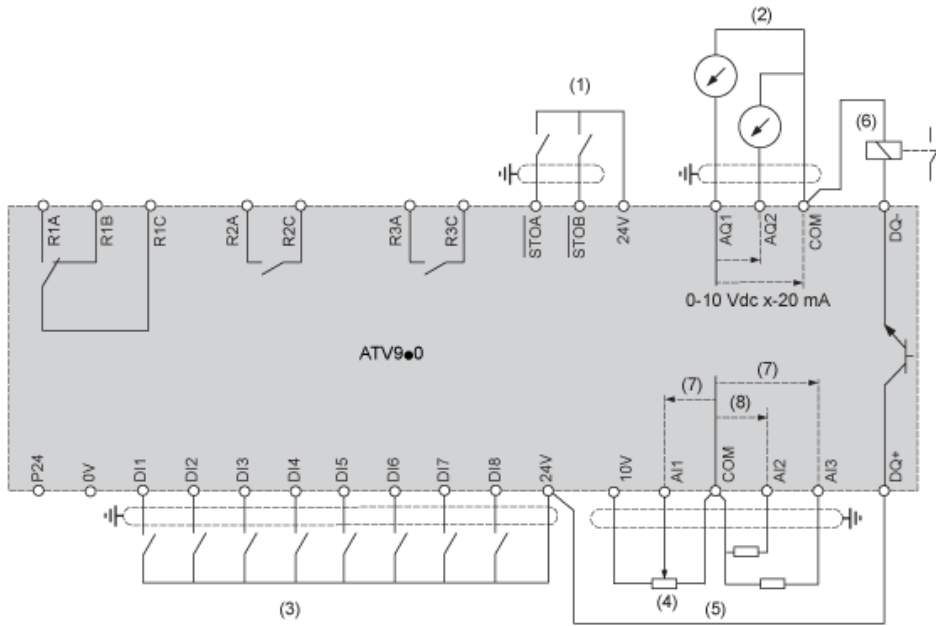

- (1) Safe Torque Off
 - (2) Analog Output
 - (3) Digital Input
 - (4) Reference potentiometer
 - (5) Analog Input
 - (6) Digital Output
 - (7) 0-10 Vdc, x-20 mA
 - (8) 0-10 Vdc, -10 Vdc...+10 Vdc
- R1A, Fault relay
 R1B,
 R1C :
 R2A, Sequence relay
 R2C :
 R3A, Sequence relay
 R3C :

Sensor Connection

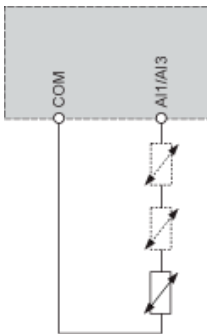

It is possible to connect either 1 or 3 sensors on terminals AI1 or AI3

Sink / Source Switch Configuration

The switch is used to adapt the operation of the logic inputs to the technology of the programmable controller outputs.

- Set the switch to Source (factory setting) if using PLC outputs with PNP transistors.
- Set the switch to Ext if using PLC outputs with NPN transistors.

Switch Set to SRC (Source) Position Using the Output Power Supply for the Digital Inputs

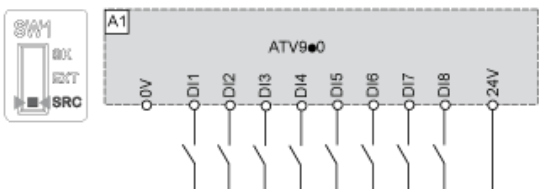

Switch Set to SRC (Source) Position and Use of an External Power Supply for the DIs

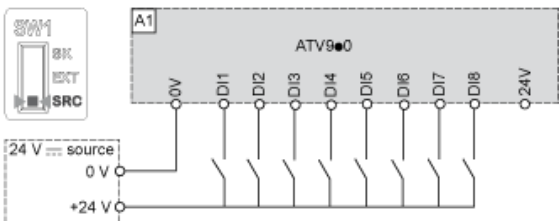

Switch Set to SK (Sink) Position Using the Output Power Supply for the Digital Inputs

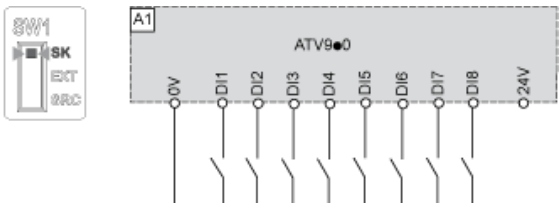

Switch Set to EXT Position Using an External Power Supply for the DIs

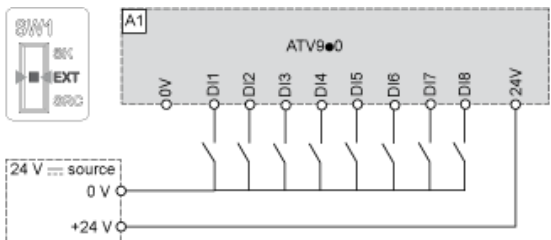

Derating Curves

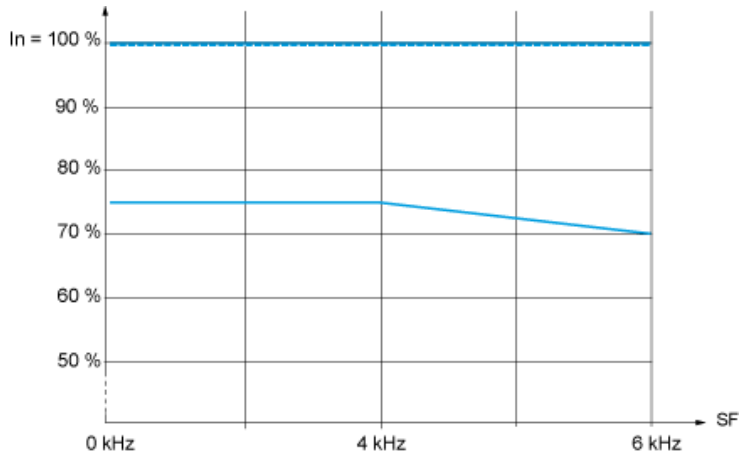

- 40 °C (104 °F) - Mounting type A, B and C
 - - - 50 °C (122 °F) - Mounting type A, B and C
 - 60 °C (140 °F) - Mounting type B and C
- In : Nominal Drive Current
SF : Switching Frequency