



CATALOG NUMBER: 320-015	
JOB NAME:	
CUSTOMER NAME:	
NOTES:	TYPE:
	DATE:

FEATURES AND SPECIFICATIONS

WALL LIGHTING
ACCESSORIES
SHIELD

Construction:
Steel



DIMENSIONS

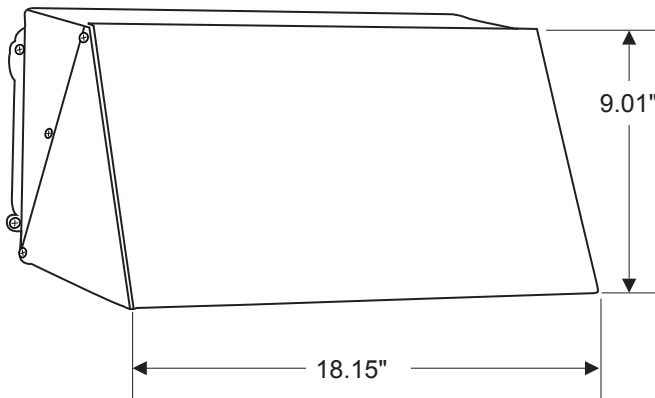

ORDERING INFORMATION

Catalog #	Description	Finish	Std. Pkg.
320-015	WLXD Full Cut-Off Shield	Bronze	1

Actual performance can vary depending on operating conditions. Specifications are subject to change without notice.