

Liquidtight Conduit Fittings

Liquidator™ Liquidtight Flexible Metallic Conduit Fittings



Cooper Crouse-Hinds® liquidtight product line offers high-quality, high-performance fittings. Designed to the toughest standards and integrating the latest technology, not only do you get a reliable and durable product, you also get one that reduces installation time and cost. Our versatile lines of liquidtight fittings are designed for a wide range of applications. Choose from our Liquidator™, LiQuik™, Zinc Die Cast, Non-Metallic or Low Profile liquidtight fittings.

Applications:

Typical applications for liquidtight conduit and liquidtight fittings include the wiring of machine tools, motors, transformers, food processing equipment, robotics, air conditioning units, illuminated store front signs and billboards, etc. The flexible metallic conduit and fittings protect conductors from mechanical damage due to vibration and movement, and seal out cutting oils, coolants, water, dust, etc. Applications such as these can be found in, but are not limited to, industries such as:

- Machine tool manufacturers
- Electric power generating plants
- Waste treatment facilities
- Paint manufacturing facilities
- Automobile manufacturing facilities
- Aerospace industries
- Breweries
- Food processing plants
- Dairies
- Pulp and paper mills
- Petroleum refineries
- Chemical and petrochemical plants

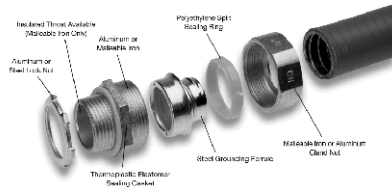

Certifications and Compliances:

- UL Listed liquidtight flexible metal conduit fittings are suitable for use in the following hazardous locations under NEC, Class I, Division 2; Class II, Division 1 and 2; and Class III, Division 1 and 2, and are suitable for grounding in sizes 3/8" through 1 1/4" under NEC.
- UL Standards: 514B, 467
- cUL Standard: C22.2 No. 18F
- UL File No. E-19189

Standard Materials:

- Body – Straight: 3/8" through 6" malleable iron, or 3/8" through 4" aluminum
- 45° – 3/8" through 4" malleable iron
- 90° – 3/8" through 4" – malleable iron or aluminum
- Gland nut – malleable iron or aluminum
- Ferrule – 3/8" through 6" – steel
- Gland nut sealing ring – polyethylene
- Sealing gasket – thermoplastic elastomer
- Locknut – steel or aluminum

Standard Finishes:

- Malleable iron – zinc electroplate
- Polyethylene, thermoplastic elastomer, aluminum and die cast – natural

Product Features	User Benefits
<ul style="list-style-type: none"> • UL Listed, cUL Certified. 	Assurance of safe and reliable performance. End user peace of mind.
<ul style="list-style-type: none"> • Provides protection in wet locations. 	Meets NEC and UL requirements for use in wet locations. Reduces downtime and replacement costs.
<ul style="list-style-type: none"> • Available in various configurations in various trade sizes and materials. 	Complete selection of styles and sizes. Easy selection from one source, saves time and money.
<ul style="list-style-type: none"> • Hex surfaces on gland nut and body. 	Easy wrenching. Fast, easy installation results in labor savings.
<ul style="list-style-type: none"> • Thermoplastic elastomer sealing gasket effectively seals out water, oil, dust and dirt. 	Eliminates leakage, potential downtime and replacement costs.
<ul style="list-style-type: none"> • Lock nut bites into box. 	Provides a reliable ground and safety of personnel and equipment. Won't vibrate loose.
<ul style="list-style-type: none"> • Cupped long grounding ferrule is distortion-free. 	Provides excellent pullout strength, prevents conduit popout and provides grounding for safety of personnel and equipment.

Liquidtight Fittings Selection Chart

Family	Material	Size/Range	Configurations	Typical Applications
Liquidator	Malleable Iron	3/8"–6"	Straight, 45°, 90°	Tough, industrial, corrosive for STANDARD APPLICATIONS
Liquidator Aluminum LT-SA	Copper-free Aluminum	3/8"–4"	Straight & 90°*	Tough, industrial, corrosive applications where ALUMINUM MATERIAL PREFERRED
LTK Low Profile	Steel/Malleable Iron	3/8"–2"	Straight, 45°, 90°	Tough, industrial, corrosive applications with SPACE RESTRICTIONS
LTQ LiQuik	Malleable Iron	3/8"–2"	Straight, 45°, 90°	Tough, industrial, corrosive applications needing NO DISASSEMBLY INSTALLATIONS
LTDC Zinc Die Cast	Zinc Die Cast	3/8"–4"	Straight & 90°	Tough, industrial, corrosive applications where ZINC DIE CAST MATERIAL PREFERRED
LTNM Non-Metallic	Nylon	3/8"–2"	Straight & 90°	Tough, industrial, corrosive for use with NON-METALLIC TYPE B LIQUIDTIGHT CONDUIT

* 90° LT-SA available in 3/8"–2" only

Liquidtight Conduit Fittings

Liquidator™ Liquidtight Flexible Metallic Conduit Fittings



CP

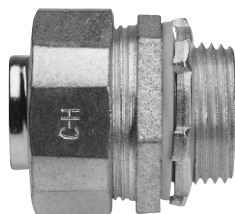

Straight Connectors

Malleable Iron							Aluminum	
Conduit Size	Non-Insulated Cat. No.	Insulated Cat. No.	Non-Insulated with Aluminum Grounding Lug Cat. No.	Insulated with Aluminum Grounding Lug Cat. No.	Insulated with Copper Grounding Lug Cat. No.	Lug Size	Non-Insulated Aluminum Cat. No.	Non-Insulated with Aluminum Grounding Lug Cat. No.
3/8"	LT38	LTB38	LT38G	LTB38G	LTB38GC	#4-#14	LT38 SA	LT38G SA
1/2"	LT50	LTB50	LT50G	LTB50G	LTB50GC	#4-#14	LT50 SA	LT50G SA
3/4"	LT75	LTB75	LT75G	LTB75G	LTB75GC	#4-#14	LT75 SA	LT75G SA
1"	LT100	LTB100	LT100G	LTB100G	LTB100GC	#4-#14	LT100 SA	LT100G SA
1 1/4"	LT125	LTB125	LT125G	LTB125G	LTB125GC	#4-#14	LT125 SA	LT125G SA
1 1/2"	LT150	LTB150	LT150G	LTB150G	LTB150GC	#4-#14	LT150 SA	LT150G SA
2"	LT200	LTB200	LT200G	LTB200G	LTB200GC	#4-#14	LT200 SA	LT200G SA
2 1/2"	LT250	LTB250	LT250G	LTB250G	LTB250GC	#1/0-#8	LT250 SA	LT250G SA
3"	LT300	LTB300	LT300G	LTB300G	LTB300GC	#1/0-#8	LT300 SA	LT300G SA
3 1/2"	LT350	LTB350	LT350G	LTB350G	LTB350GC	#3/0-#6	LT350 SA	LT350G SA
4"	LT400	LTB400	LT400G	LTB400G	LTB400GC	#3/0-#6	LT400 SA	LT400G SA
5"	LT500†	LTB500†	LT500G†	LTB500G†	—	250MCM-#6	—	—
6"	LT600†	LTB600†	LT600G†	LTB600G†	—	250MCM-#6	—	—

†Not UL Listed or CSA Certified

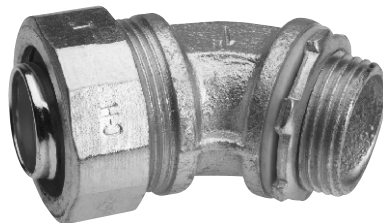

45° Angle Connectors

Malleable Iron							Aluminum
Conduit Size	Non-Insulated Cat. No.	Insulated Cat. No.	Non-Insulated with Aluminum Grounding Lug Cat. No.	Insulated with Aluminum Grounding Lug Cat. No.	Insulated with Copper Grounding Lug Cat. No.	Lug Size	Non-Insulated Aluminum Cat. No.
3/8"	LT3845	LTB3845	LT3845G	LTB3845G	LTB3845GC	#4-#14	—
1/2"	LT5045	LTB5045	LT5045G	LTB5045G	LTB5045GC	#4-#14	—
3/4"	LT7545	LTB7545	LT7545G	LTB7545G	LTB7545GC	#4-#14	—
1"	LT10045	LTB10045	LT10045G	LTB10045G	LTB10045GC	#4-#14	—
1 1/4"	LT12545	LTB12545	LT12545G	LTB12545G	LTB12545GC	#4-#14	—
1 1/2"	LT15045	LTB15045	LT15045G	LTB15045G	LTB15045GC	#4-#14	—
2"	LT20045	LTB20045	LT20045G	LTB20045G	LTB20045GC	#4-#14	—
2 1/2"	LT25045	LTB25045	LT25045G	LTB25045G	LTB25045GC	#1/0-#8	—
3"	LT30045	LTB30045	LT30045G	LTB30045G	LTB30045GC	#1/0-#8	—
3 1/2"	LT35045	LTB35045	LT35045G	LTB35045G	LTB35045GC	#3/0-#6	—
4"	LT40045	LTB40045	LT40045G	LTB40045G	LTB40045GC	#3/0-#6	—

Liquidtight Conduit Fittings

Liquidator™ Liquidtight Flexible Metallic Conduit Fittings



Non-Insulated Malleable Iron Dimensions (in inches)

CP

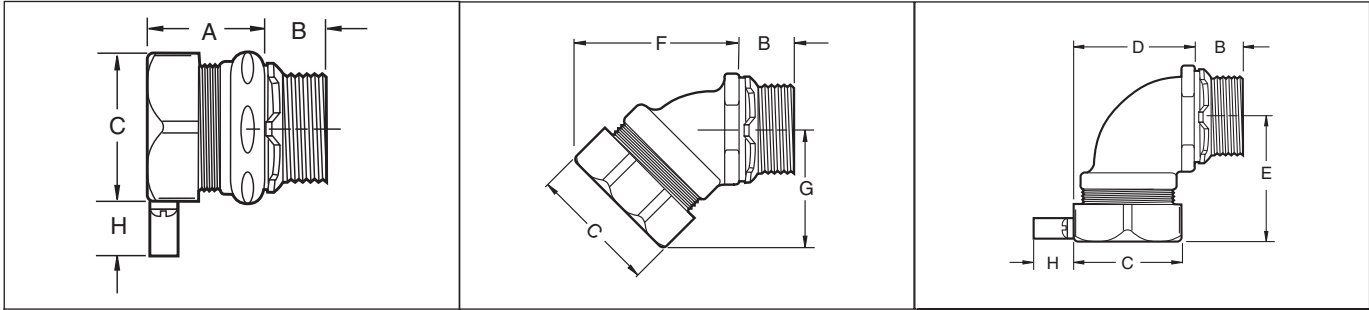

Trade Size	A	B	C	D	E	F	G	H
3/8"	1 1/8"	1/2"	1 1/8"	1 5/16"	1 5/8"	1 15/16"	1 1/2"	3/4"
1/2"	1 1/4"	1/2"	1 1/4"	1 7/16"	1 5/8"	2"	1 1/2"	3/4"
3/4"	1 1/4"	1/2"	1 9/16"	1 5/8"	1 3/4"	2 3/16"	1 9/16"	3/4"
1"	1 7/16"	5/8"	1 13/16"	2 5/16"	2 1/8"	2 1/2"	1 13/16"	3/4"
1 1/4"	1 1/2"	1 1/16"	2 1/4"	2 3/8"	2 1/4"	2 13/16"	2 3/16"	3/4"
1 1/2"	1 5/8"	3/4"	2 7/16"	3 11/16"	2 3/8"	3"	2 7/16"	3/4"
2"	1 3/4"	3/4"	3"	3 3/16"	2 3/4"	3 11/16"	2 13/16"	3/4"
2 1/2"	2 3/16"	1"	4"	8 5/16"	8 3/16"	7 5/16"	4 7/16"	1 1/8"
3"	2 1/2"	1 1/8"	4 3/16"	9 13/16"	9 3/8"	7 5/8"	5 1/2"	1 1/8"
3 1/2"	2 5/8"	1 3/16"	5 1/4"	11 3/16"	11 1/4"	9 5/8"	5 5/16"	1 1/2"
4"	2 3/4"	1 1/4"	5 3/4"	13"	12 3/16"	11 1/16"	8 5/16"	1 1/2"
5"	3 1/8"	1 7/16"	6 1/16"					1 11/16"
6"	3 3/8"	1 1/2"	7 3/4"					1 11/16"

Non-Insulated Aluminum Dimensions

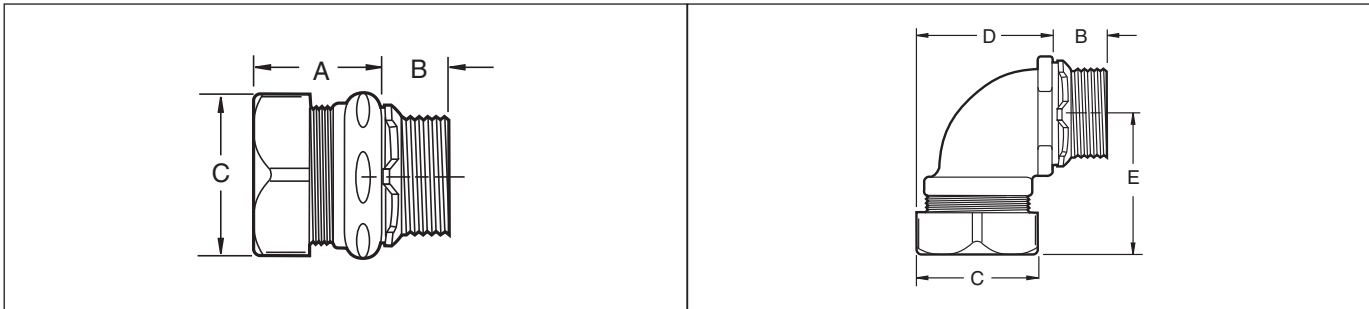

Trade Size	A	B	C	D	E
3/8"	1 3/16"	19/32"	1 1/4"	1 7/16"	1 3/8"
1/2"	1 5/16"	19/32"	1 1/4"	1 1/2"	1 3/8"
3/4"	1 5/16"	19/32"	1 1/2"	1 11/16"	1 1/2"
1"	1 7/16"	13/16"	1 3/4"	2"	1 13/16"
1 1/4"	1 9/16"	13/16"	2 1/4"	2 1/16"	2 5/32"
1 1/2"	1 13/16"	13/16"	2 1/2"	2 13/16"	2 7/16"
2"	1 3/4"	7/8"	3"	3 3/16"	2 7/8"
2 1/2"	2 1/4"	1 1/16"	3 3/4"		
3"	2 7/16"	1 1/8"	4 1/2"		
3 1/2"	2 7/8"	1 3/16"	5 1/8"		
4"	2 15/16"	1 1/4"	5 5/8"		